

RELAYS

CONTENTS

	<i>Page</i>
DUO CIRCUIT RELAY	3
MULTI-CONTACT RELAY	11
HIGH SPEED RELAY (Collator)	28
SLATE BASE RELAY	29
HIGH SPEED RELAY (No. 202800)	30
HEAVY DUTY RELAY	31
WIRE CONTACT RELAY	33
Wire Contact Relay Testing Device—Part 454199	39
CARD COUNTING DIAL RELAY	43

RELAYS

General

Engineering requirements and specifications are becoming increasingly more exact in regard to the relays used in IBM equipment.

Relays of many varying characteristics have been designed and built by our engineering and manufacturing organizations. Extraordinary care enters into the development and production processes as well as into the selection and installation of relays. These units must perform definite functions within specified time limits. In order that trouble-free operation may continue after machine installation in the field, it is vitally important that these relay units be properly maintained by the customer engineering department.

This manual is intended to provide the customer engineer with a source of information regarding relays, their care and adjustment.

Types of Relays

There are several distinct types of relays used in IBM Electric Accounting Machines. They will be presented in the following order:

1. Duo circuit relay
2. Multi-contact relay

3. High speed relay (Collator)
4. Slate base relay
5. High speed relay (No. 202800)
6. Heavy duty relay
7. Wire contact relay
 - A. Wire contact relay testing device—Part 454199
8. Card counting dial relay

Relay Operating Speed

Several factors which affect relay operating speed in a circuit are the number and type of contacts, the voltage and current available, and the mechanical adjustment of the unit. Any deviation from prescribed standard adjustments, such as armature-core air gap, contact point adjustment and contact strap tension will affect the speed of the relay.

It is desirable to maintain a 100% safety factor in the operating speed of relays, that is, the impulse available to operate any relay should be at least twice as long as the rated operating time for that relay. The smaller the safety factor, the less dependable the circuit will be in operation.

It is strongly recommended that the dynamic timer be used wherever applicable to determine relay operating speeds and safety margins.

Milliseconds

Relay operating time is commonly expressed in milliseconds. A millisecond is 1/1000 second or .001 second and is abbreviated MS.

The formula for converting machine speed to milliseconds is as follows:

$$\frac{\text{MS}}{\text{Index Division}} = \frac{60,000}{\text{RPM} \times \text{No. of Index Divisions}}$$

CONVERSION CHART—MACHINE TIME TO MILLISECONDS

Type	Degrees or Cycle Points	RPM	MS/Index Division	RPM	MS per Index Division
*077	360°	240	.694		
078	360°	150	1.111		
079	360°	150	1.111		
080	16 pt.	450	.834		
089	360°	240	.694		
101					
Card Feed	16 pt.	450	8.33		
H. S. Acc.	11 pt.	450	12.42		
Print Cycle	20 pt.	130	23.08		
285	16 pt.	75	50.000	150	25.000
		120	31.250		
376	16 pt.	75	50.000	120	31.250
		100	37.500	150	25.000
402-403	360°	100	1.666	150	1.111
405	360°	80	2.083	150	1.111

Continued from preceding page.

Type	Degrees or Cycle Points	RPM	MS/Index Division	RPM	MS per Index Division
407	360°	150	1.111		
513	14 pt.	100	42.850		
514	14 pt.	100	42.850		
515	14 pt.	100	42.850		
517	14 pt.	100	42.850		
518	14 pt.	100	42.850		
519	360°	100	2.571		
520	14 pt.	100	42.850		
521	14 pt.	100	42.850		
551	16 pt.	75	50.000		
552	360°	60	2.777		
601	16 pt.	150	25.000		
602	360°	200	.833		
602A	360°	200	.833		

*Speed varies in parts of cycle.

DUO CIRCUIT RELAY

THE DUO RELAY, as the name implies, provides simultaneous control over several different circuits. It is used over a wide range of operating speeds and contact point combinations in most IBM machines. There are short and long frame relays; also one and two core relays. Various combinations of coils and contact points provide relays of large or small current drain, slow or fast pickup speed, and slow or fast drop-out speed. Suitable circuit combinations and relay design may provide for delayed action in either the pickup or drop-out time of these relays.

Figure 1 illustrates several types of duo relays.

- 1-A. Single coil, single core duo relay.
- 1-B. Two coil, single core duo relay.
- 1-C. Three coil, double core duo relay.

Duo Relay Adjustment

The function of a relay is the dependable opening and closing of circuits within given time limits. Proper adjustment is equally as important as proper design for successful operation.

Visual Inspection

Before adjusting any duo relay, a visual check should be made of the following items:

1. Core firmly secured to the frame.
2. Loose or burned contact points.
Contact points which are loosely

held to the strap may cause bouncing and poor contact.

3. Contact point alignment. All contact points should be aligned vertically and horizontally, so that all points utilize the greatest contact area in both the de-energized and energized positions.
4. Contact pile holding screws tight.
5. Clean contact points.
 - (a) Remove loose dust with a brush.
 - (b) Remove caked or oily dust by moistening and flushing out with carbon tetrachloride. The carbon tetrachloride should be placed in a small container such as an accounting machine ribbon box and replaced when it becomes dirty. Dirty carbon tetrachloride will do more harm than good. Use a clean brush.
 - (c) Remove films by burnishing with the metallic burnishing tool. A burned deposit surface on silver contact points may be removed with a good quality contact file which should be followed by use of the burnishing tool. A flexstone should *not* be used on silver points.

A burned tungsten point should be cleaned with a flexstone after which a burnishing tool should be used to remove any residual abrasive. A chamois cloth or the finger dipped in carbon tetrachloride will serve to remove any

residual particles of abrasive. The contact should then be wiped with a clean cloth.

6. (Remove armature to check items 6 and 7.) Worn, sticking, or damaged armature; pivot pin must turn freely in the armature ears. Any armature movement lost due to worn armature pivots is multiplied in the amount of rise and wipe lost. Saturate a pipe cleaner with light oil and draw it through the pivot holes in the armature to remove the

foreign matter and lubricate the pivot points.

7. Remove foreign particles between armatures and magnet core; armature and brass stop pin.

Armature Freeness

The armature should be perfectly free on its pivot pin with a slight end play of $.010'' \pm .006''$. Pivot pin and ears of armature should be free of burrs. Bend armature ears to adjust for end play (Figure 1A).

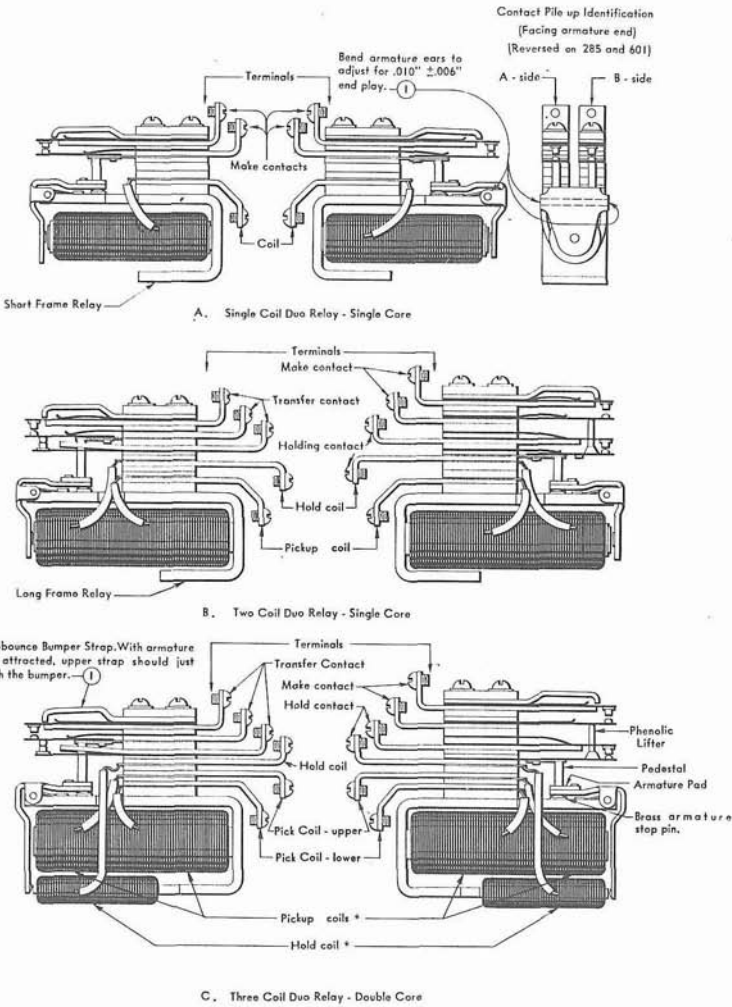

C. Three Coil Duo Relay - Double Core

* See text on Three Coil Relays

Figure 1. Typical Duo Relays

Armature Squareness

With the armature held in the attracted position, the residual pin should rest squarely against the core face and the armature should be parallel with the core face. Corrections should be made by bending or replacing the armature (Figures 2A and 2B).

Residual Pin (Figures 2A and 2B)

The residual pin should project $.005'' + .005'' - .002''$ from the armature. This may be checked by inserting the required thickness gauge between the fully attracted armature and core, on each side of the residual pin. In all cases a $.003''$ gauge should be free and a $.010''$ gauge should not go. This is also an excellent method of determining armature squareness.

Armature Air Gap

It is of the utmost importance that specified air gap dimensions be maintained. Any deviation from this specified gap will affect pickup and drop-out time. Variations in these adjustments may improve operation on one application but may cause failures on another. A specific air gap dimension is determined for proper operation on all applications for which a relay is selected to operate; for example, decreasing the air gap will decrease the pickup time but will also increase the drop-out time.

Air gap dimensions given to the field in the past were those known as the "Reference Air Gap." This is a factory adjustment measurement and is determined by inserting a thickness gauge between the armature (de-energized) and core, to a point half-way through the residual pin (Figure 3).

To facilitate field adjustment procedures, these air gap dimensions have been restated in terms of a "Measured Through Residual" condition (Figure 4) and are those specified in this manual.

Duo relays are of two general types, namely, single core and double core. Several different air gap dimensions have been specified for the relays within these two classifications.

The several specific armature-core air gap dimensions for single and double core relays are shown in the table on the following page.

Armature Air Gap Adjustment

With the armature in the fully de-energized position insert the specified thickness gauge completely through

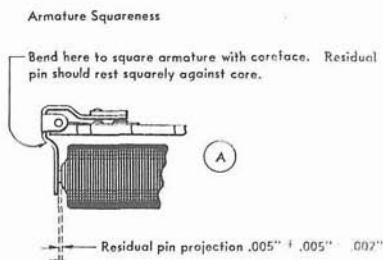

Figure 2A

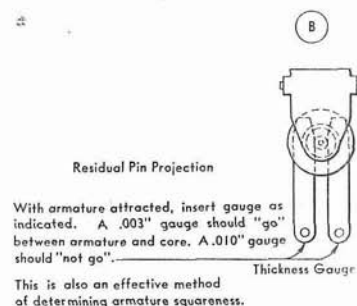

Figure 2B

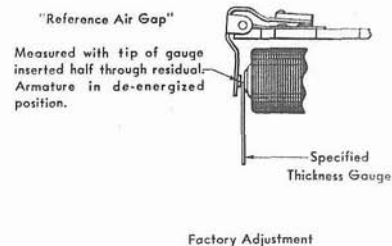

Figure 3

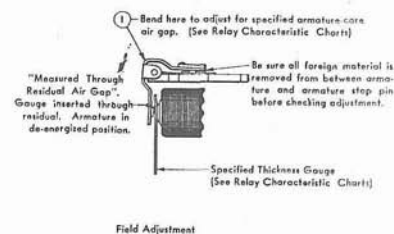

Figure 4

Relay Type	"Measured Through" Air Gap	Remarks
1. Single Core	.013" + .000" - .001" .016" + .000" - .002" .021" + .000" - .003"	
2. Double Core		
(a) lower core	.028" + .000" - .003" .036" + .000" - .003"	Measured at lower core Measured at lower core
(b) upper core	.004" + .001" - .001"	Measured at upper core (Clearance, no residual)

Note: Relay Characteristic Charts, by machine type, are included in this manual to provide the specific armature-core air gap dimension for each relay.

residual to measure the gap. To adjust, bend the armature at the point indicated in the illustration (Figure 4).

The armature-core air gap dimensions for double core relays are measured between *the armature and the lower core*. With the armature attracted there should be .003" to .005" clearance between the armature and the upper core (Figure 4A).

Note: Armature and core air gap dimensions are specified by machine and by relay position number in the Relay Characteristic Chart accompanying this manual.

Copperplated Armatures

Duo relays installed on machines shipped during recent months are equipped with copperplated armatures instead of the cadmium plated type formerly used. Furthermore, these new armatures do *not* have a residual pin.

The purpose of these changes is to improve the operating efficiency of duo relays and to provide for more trouble-free operations.

1. The copperplating tends to limit the formation of "red rust" in the armature pivot holes, thus preventing freezing of the pivot pin to the armature.
2. Removing the residual pin eliminates variations in armature travel and in residual magnetism effects due to flattened residual pins. The residual pin effect is provided by using a brass screw and a brass washer to hold the core and yoke together.

Copperplated Armature Adjustment

Armature-core air gap dimensions specified in the Duo Relay Characteristic Charts are to be applied to those relays equipped with copper-

Two Core Relays

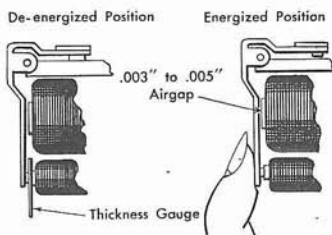

See Relay Characteristic Chart for Specified Air-Gap Dimension for Two Core Relays

Figure 4A

plated armatures. The air gap dimensions are to be measured by inserting the thickness gauge completely through the core face.

Note: Do *not* replace the copperplated armature with a cadmium plated armature (with residual pin) unless the brass screw and washer are also replaced with a standard screw.

Relay Contact Points

Most relay contact points are made of solid silver; some are made of tungsten. Silver points are generally used where the pressure is light, and the point is not breaking a heavy current. Tungsten points are generally used where the pressure is heavy, and the point is breaking a heavy circuit.

Most relay points which are made of tungsten are the larger size; however, some relays such as 15 and 16 on the Type 405 machine have tungsten points of the smaller size. Silver points tarnish and appear black and dirty; this tarnish, however, is conductive and should not cause trouble.

Maximum current and voltage capacities for duo relay contact points are 5 amperes at 130 volts.

Contacts are mounted on these relays in two piles, right and left. Facing the armature, those on the left side are designated A; upper and lower, AU and AL. Those on the right are known as B points; upper and lower, BU and BL. Exceptions to this are the duo relays on the Type 285 and Type 601 machines. Relay points on the left on these machines facing armature are known as B points and those on the right, A points (Figure 1A).

Contact Point Adjustment

Prior to checking and adjusting contacts it is absolutely necessary that armature-core air gap dimensions be adjusted correctly, as specified; also check residual pin for proper projection.

Procedure (Figure 5):

1. Insert the specified thickness gauge between armature and

core. (See contact adjustment A of Relay Characteristic Chart.)

2. Press on armature to hold gauge and thus place the armature in the adjustment position.
3. Holding armature in this position, adjust all contact point air gaps for a *minimum clearance* (.001" to .002") between points (see B). Points should *not* touch but the slightest perceptible movement should cause them to touch.
4. Remove adjustment gauge A and check the making and breaking conditions of the points in both the energized and de-energized positions as follows:

Armature in Energized Position

N/O points, C strap, should be lifted approximately .010" off supports or have enough flex to insure good contact.

N/C points should have an air gap of .012" to .020".

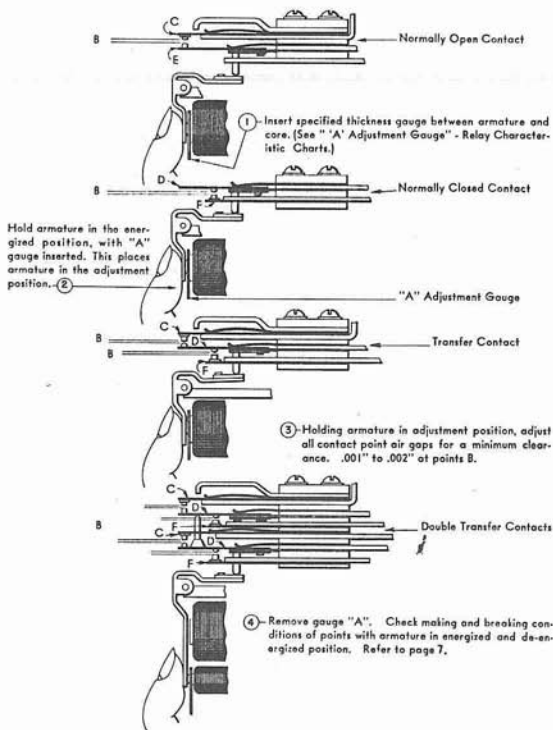

Figure 5. Contact Point Adjustments

Armature in De-energized Position

N/O points should have an air gap of .012" to .020".

N/C points, F strap, should be lifted approximately .010" off the support strap.

Check

In checking transfer contact point operation, be sure the normally closed points break before the normally open points make.

Contact Strap Tension

Proper contact strap tension is very essential to dependable relay operation. This tension is measured in terms of grams by applying a gram gauge to each contact strap.

Figure 6 illustrates the various types of relay contacts. The individual straps of these contacts are labeled by the letters C, E, D and F for identification purposes only in this manual.

The gram gauge is to be applied to the contact strap at the point of contact, in the opposite direction to the normal spring tension as indicated in the illustration.

Adjustments

Contact straps are to be adjusted for the following conditions with specified gauge tension applied (Figure 6). Also, refer to the table below.

1. (a) Strap C—N/O contact) 29 or 45 grams tension.*
- (b) Strap C—(Transfer contact) 29 or 45 grams tension.*

C straps should be lifted just clear of the contact support strap.

2. Strap E—17 grams.

Pedestal of this strap should just clear the armature pad by .005". In a contact pile up, the upper strap E should just clear the phenolic lifter.

3. Strap D—34 grams.

Pedestal of this strap should be just lifted clear of the armature pad, with tension of F strap held away.

In a contact pile up (double transfer points) upper D strap must just clear the phenolic lifter, with F strap held away.

4. Strap F—17 grams.

Strap F should be lifted .005" off the support strap without assistance from strap D. Maximum tension should never cause the pedestal of strap D to rise off the armature pad.

*Relays (part number) 121837, 122-499 and 142368 are relatively fast units. The C straps of all transfer and N/O contacts on these relays must be adjusted for 29 grams tension. Transfer and N/O contact C straps on all other duo relays are to be adjusted for 45 grams tension.

Anti-Bounce Bumper Straps

Adjust bumper straps so that contact strap C just touches bumper with the armature in the fully attracted position. All C contact straps (upper) of relays having a pickup time of 10 MS or less are equipped with these bumper straps (see Figure 1C).

Sealing

This term is used to describe the position of the armature in fully energized position with residual pin touching the core. Relays using 40-volt coils must seal at a maximum of 25 volts. Relays using 110-volt coils must seal at a maximum of 80 volts.

Contact Strap Tension Table

Contact Type	Strap	Tension in Grams	Tolerance
1. Transfer	C	* { 29 Grams	± 5
		{ 45 Grams	± 5
	D	34 Grams	± 10
	F	17 Grams	± 4
2. Normally Closed	D	34 Grams	± 10
	F	17 Grams	± 4
3. Normally Open	C	* { 29 Grams	± 6
		{ 45 Grams	± 6
	E	17 Grams	± 4

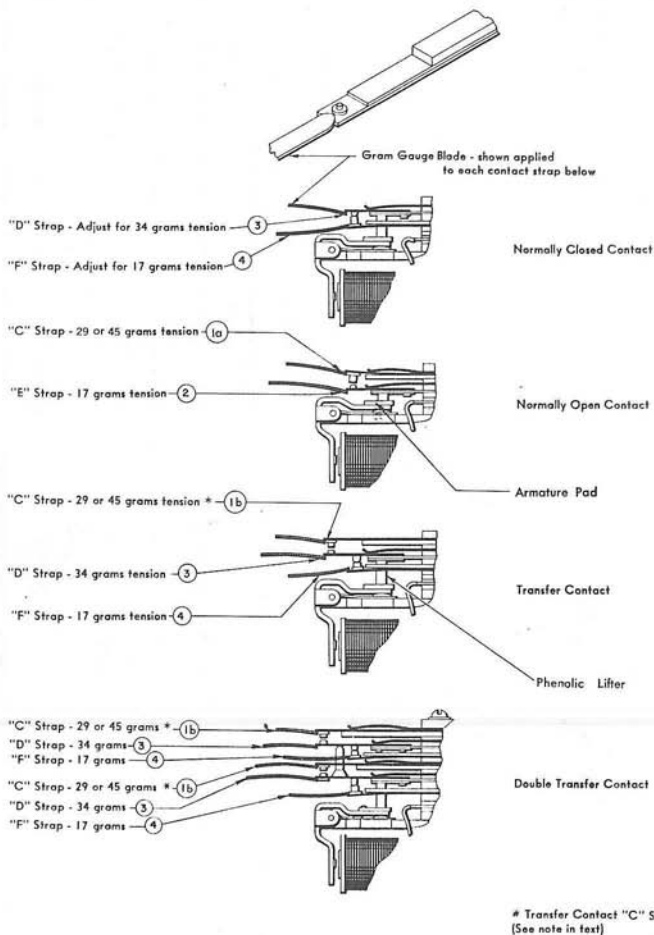

Figure 6. Contact Strap Tension

Polarity of Relay Coils

The coils of two-coil relays must be of the same polarity, except for the coils of relay number 159758 which have unlike polarity. The latter is used in the IBM Proof Machine.

Three-coil relays must be checked for like polarity of the coils on the upper core. The coil on the lower core must be of unlike polarity, relative to the upper coils.

Suggested Method for Polarity Check

A small permanent bar magnet may be effectively used in determining like and unlike polarity between relay coils by the comparison method.

Remove armature from relay and energize one coil. Hold bar magnet to core face. It should either attract or repel. De-energize first coil and repeat same operation on coils two and three. By holding same pole of bar magnet to core, the action (attraction or repulsion) may be compared to action when first coil was energized thus permitting a determination of like and unlike polarity.

Three-Coil Relays

There are two types of three-coil relays:

1. Type one has a pickup and a hold coil on the upper core and a pickup coil on the lower core. On this relay, coil number

128024 is wound on the lower core, serving as a pickup coil and is designed to provide just as fast and powerful a digit pickup as the pickup coil on the upper core. Pickup coils of this relay are isolated on different cores to prevent the possibility of magnetic interference between coils, under certain combinations of control panel wiring. It is used in the Type 405 selector circuits.

2. Type two has two pickup coils wired on the upper core and the hold coil on the lower core. An example of the use of this relay is R-42 in the Type 921 and Type 405 circuits.

Thermal Delay Relay #206314

An interval of time must be allowed for the cathodes of vacuum tubes to warm up before the machine is placed in operation. This time delay or "warm up" is effected by a thermal delay relay.

One contact strap of this relay is made of two strips of metal placed one on top of the other and bonded together. These two metals expand at different rates when heated. A coil of high resistance wire wound around the strap is the heating element. The greater expansion of the lower strip of metal causes the bimetal strap to bend upward until it makes contact with another point. This second point is in the form of a screw tipped with contact metal. This screw provides a means of varying the time interval required for the relay to be energized (Figure 7). The distance between the

contact points will determine the time required for energization. If more time is desired, increase the air gap by backing off the screw; if less time is desired, decrease the air gap by turning in the screw. The lock nut locks the upper point in position to maintain the adjustment. The adjusting screw is normally set to provide 50 seconds' delay with a tolerance of plus ten seconds, minus five seconds. Use .095" as a starting point when making this adjustment.

This time is applicable when starting with a cold machine. If, when this relay is being adjusted, the machine is turned ON and OFF several times, the temperature of the heat unit will have a cumulative effect and the time required for pickup will decrease.

The above relay operates on 40-volt current and is employed in the circuits of Machine Types 077, 513 and 519.

Duo Latch Relay Assembly #101959 (Figure 8)

This relay is used in the buzzer circuit of the Proof Machine, Type 801. It is special in that the AU N/O contact points are equipped with a latching mechanism. When the relay becomes energized, the latch moves under the contact and holds the points (AU) closed. These points are opened when the unlatching coil (lower core) is energized, moving the latch away from the contact AU. This prevents the operator from opening the buzzer signal circuit by turning machine main line switch OFF.

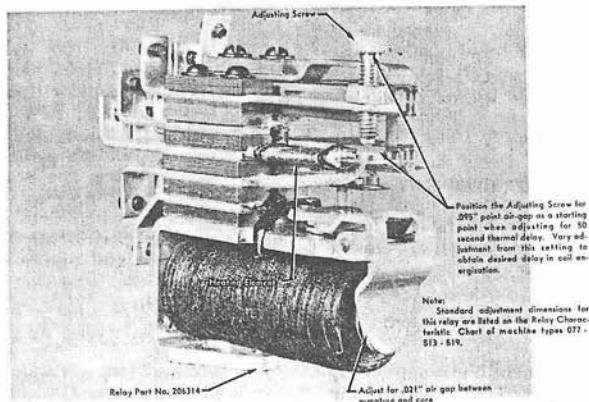

Figure 7

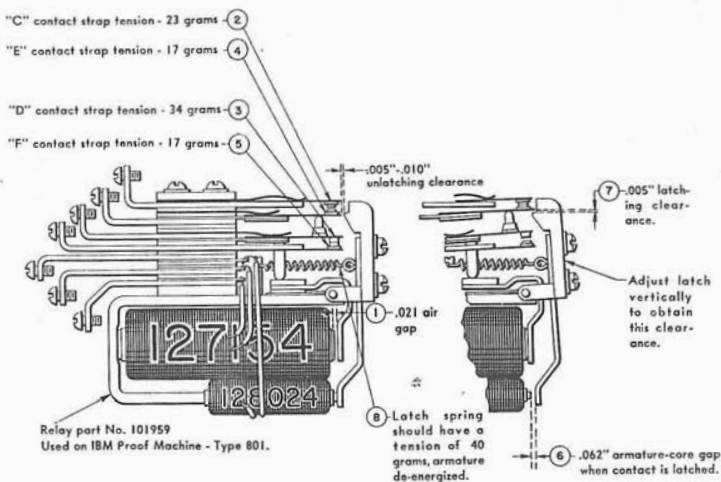

Figure 8. Duo Latch Relay Adjustments

1. .021" air gap—Contact Adjustment A Gauge—.012".
2. C contact strap tension—23 grams.
3. D contact strap tension—34 grams.
4. E contact strap tension—17 grams.
5. F contact strap tension—17 grams.
6. .062" air gap when contact strap is latched.
7. .005" latching clearance, when relay armature (upper) is attracted.
8. Latch spring should have a tension of 40 grams, measured at point indicated.
9. The AU contact points must be made when resting on the latch and main line switch is turned off.

MULTI-CONTACT RELAY

THE MULTI-CONTACT type relay is similar in principle to the duo relay, differing mainly in the number of contacts it is designed to control (Figure 9). It consists of two pairs of mag-

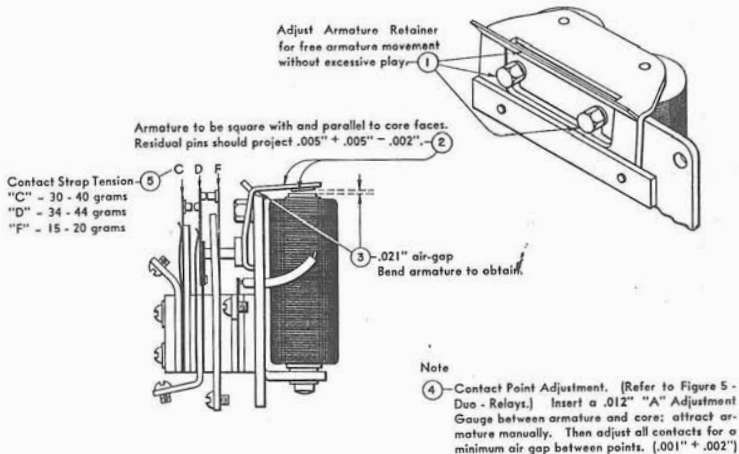

Figure 9. Multi-Contact Relay

nets, two armatures and usually twelve contacts. The two pairs of magnet coils are connected to each other either in series or parallel, depending upon their application. The contacts are either of the normally open or transfer type.

These relays are not being used to any extent at the present, except on the Types 285 and 601 machines. The X-R multi-contact relay in the Type 405 also represents an application for this type relay.

MCR Adjustments (Figure 10)

1. ARMATURE FREENESS

The armature should be free at its pivot point without having excessive play. Adjust the armature retainer to obtain this condition.

2. ARMATURE SQUARENESS - RESIDUAL

With the armature held in the attracted position it should be parallel and square with the core faces; both residuals should strike their respective core face squarely. The residual pin should project $.005'' + .005'' - .002''$ and may be checked similarly to the method shown in Figure 2 on duo relays.

3. ARMATURE-CORE AIR GAP

The armature-core air gap should be checked with the thickness gauge inserted "Through the Residual." This clearance should be set for $.021''$ and may be obtained by bending the armature.

4. CONTACT POINT ADJUSTMENT

- Insert a $.012''$ thickness gauge between the armature and cores.
- Hold the armature in the attracted position.
- Adjust contact strap supports for a *minimum clearance* $.001''$ to $.002''$ between both normally open and normally closed points. Check to see that normally closed points break before normally open points make (Figure 5).

5. CONTACT STRAP TENSION

- MCR used on 285 and 601 machines
C contact strap—30 to 40 grams
D contact strap—34 to 44 grams
F contact strap—15 to 20 grams
- X-R MCR used on 405 machine
C contact strap—30 to 40 grams
F contact strap—15 to 20 grams

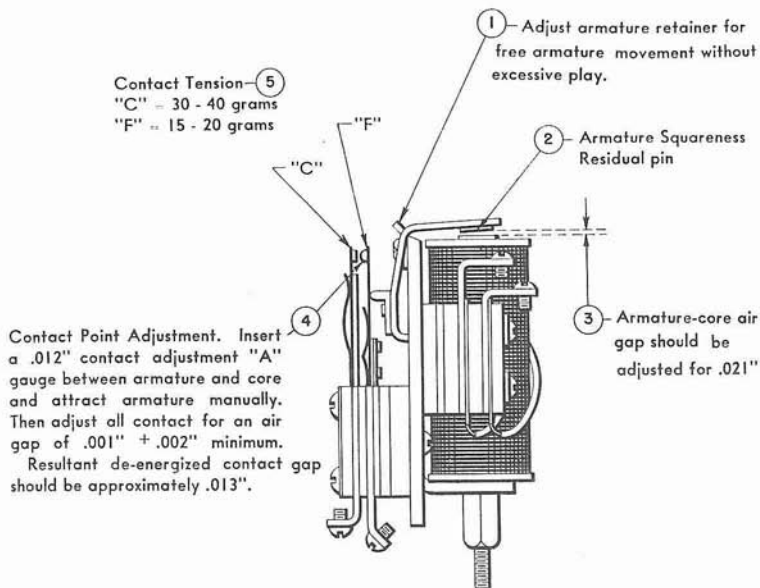

Figure 10. X-R, MCR of Type 405

DUO RELAY CHARACTERISTIC CHART

Machine Type 031
Wiring Diagram No. 170300-D

Relay Position Number	Relay Part Number	Relay Coil Number	Armature Core Airgap "Through"	Contact Adjustment "A" Gauge	Operating Time in Milliseconds	
					Pickup	Drop-out
R1-R14	111281	111280	.021	.012	2.5-4	4-7
R15-R16	111331	111330	.021	.012	4-6.5	2.5-4
R17	132008	132000	.021	.012	3-5	3-8
R18	177287	111390	.021	.012	14	2-4.5

Machine Type 036
Wiring Diagram No. 103239-A

1-9	186346	111350	.016	.010		
10-15	111351	111350	.021	.012	12-16	3.5
16-17	11401	111400	.021	.012	16-20	3-6
18	124843	111350	.016	.010	17-23	2-4
19	177287	111390	.021	.012	14-16	2-4.5
20	111401	111400	.021	.012	16-20	3-6

Machine Type 042
Wiring Diagram 196470

1	121058	26476	.016	.010	4-6	4-10
2-3	111354	111350	.016	.010	10-14	4.5-7.5
4	121054	121059	.021	.012		
5	111354	111350	.016	.010	10-14	4.5-7.5
6-7	124843	111350	.016	.010	17-23	2-4
8	121058	26476	.016	.010	4-6	4-10
9	111351	111350	.021	.012	12-16	3-5
10	128293	111350	.016	.010	13-18	3-5
11	127705	121059	.016	.010	5-7	4.5-6.5
12	111351	111350	.021	.012	12-16	3-5
13	182693	26476	.016	.010	7-9.5	3-5
14	111351	111350	.021	.012	12-16	3-5
15	153073	26476	.016	.010	6-8	2-5
16	123875	26476	.021	.012	5-8	5.5-6.5
17-18	182693	26476	.016	.010	7-9.5	3-5
19	111351	111350	.021	.010	12-16	3-5
20	127050	26476	.016	.010	6.5-8.5	2-4
21	153073	26476	.016	.010	6-8	2-5
22	121054	121059	.021	.010		
23	121053	121059	.016	.010	4.5-6.5	5-7
24	111354	111350	.016	.010	10-14	4.5-7.5
25	127705	121059	.016	.010	5-7	4.5-6.5
26	142368	127154 122181	.028	.015	5-7	6-10
27-36	127705	121059	.016	.010	5-7	4.5-6.5
37-38	142368	127134 122181	.028	.015	5-7	6-10
39	178103	111350	.016	.010	13-17	1.5-5.5
40	111354	111350	.016	.010	10-14	4.5-7.5

Continued on next page.

Continued from preceding page.

Machine Type 042
Wiring Diagram No. 196470

Relay Position Number	Relay Part Number	Relay Coil Number	Armature Core Airgap "Through"	Contact Adjustment "A" Gauge	Operating Time in Milliseconds	
					Pickup	Drop-out
41	127050	26476	.016	.010	6.5-8.5	2-4
42	121877	26476	.016	.010	5-7	4-8
43-45	122532	111350	.016	.010	14-18	3-5
46	121058	26476	.016	.010	4-6	4-10

Machine Type 055
Wiring Diagram No. 149701

1-14	177287	1113573	.021	.012	14-18	2-4.5
15	155666	170187	.016	.010	7-9	6.0
16	155667	170187	.016	.010	6-8	4.5-7.5
17	111401	111400	.021	.012	16-20	3-6
18-31	177287	111390	.021	.012	14-18	2-4.5
32	111401	111400	.021	.012	16-20	3-6
33	177287	113573	.021	.012	14-18	2-4.5
34	111394	111390	.016	.010	7-9	5.5-6.5
35-36	177287	113573	.021	.012	14-18	2-4.5
37-38	111401	111400	.021	.012	16-20	3-6
39	177287	113573	.021	.012	14-18	2-4.5
40-41	189223	170187	.016	.010	8-12	2-3.5
42	197262	111390	.016	.010	11-13	4-6
43-44	189223	170187	.016	.010	8-12	2-3.5
45	155666	170187	.016	.010	7-9	6.0
46	189223	170187	.016	.010	8-12	2-3.5
47	155666	170187	.016	.010	7-9	6.0
48	282745	111400	.016	.010	20-26	2-4
49-51	177287	113573	.021	.012	14-18	2-4.5
52	155665	170187	.016	.010	7-9	4-7
53-54	177287	113573	.021	.012	14-18	2-4.5
55	111394	111390	.016	.010	7-9	5.5-6.5
6-57	111391	111390	.021	.012	9.5-13.5	4.5-7.5
'8	155667	170187	.016	.010	6-8	4.5-7.5
59	111401	111400	.021	.012	16-20	3-6

Machine Type 060
Wiring Diagram No. 196512-B

121	129036	121059	.021	.012	7-9	3-5
122	153073	26476	.016	.010	6-8	2-5
123	129036	121059	.021	.012	7-9	3-5
124-125	124843	111350	.016	.010	17-23	2-4
126	153075	113573	.021	.012	6-8	2-5
127	124843	111350	.016	.010	17-23	2-4
128-131	111351	111350	.021	.012	12-16	3-5
132	121877	26476	.016	.010	5-7	4-8
133	127050	26476	.016	.010	6.5-8.5	2-4
134-135	121053	121059	.016	.010	4.5-6.5	5-7

Continued on next page.

*Continued from preceding page.*Machine Type 060
Wiring Diagram No. 196512-B

Relay Position Number	Relay Part Number	Relay Coil Number	Armature Core Airgap "Through"	Contact Adjustment "A" Gauge	Operating Time in Milliseconds	
					Pickup	Drop-out
136-137	127050	26476	.016	.010	6.5-8.5	2-4
138-140	121877	26476	.016	.010	5-7	4-8
141-142	153073	26476	.016	.010	6-8	2-5
143	121058	26476	.016	.010	4-6	4-10
144	129036	121059	.021	.012	7-9	3-5
145	282361	121059	.016	.010	5-7	3-4
146	127705	121059	.016	.010	5-7	4.5-6.5
147	182693	26476	.016 ±	.010	7-9.5	3-5
148	Vacant					
149	111351	111350	.021	.012	12-16	3-5
150	103286	113573	.013	.008		
151	178103	111350	.016	.010	13-17	1.5-5.5
152	111351	111350	.021	.012	12-16	3-5

Machine Type 075

Cd. Lever 2	111314	111310	.016	.010	4.5-6.5	3.5-4.5
Ctr. Ctrl.	111331	111330	.021	.012	4-6.5	2.5-4

Machine Type 077
Wiring Diagram No. 193681

1	124843	111350	.016	.010	17-23	2-4
2	123998	111370	.016	.010	21-27	3-5
3	124843	111350	.016	.010	17-23	2-4
4-7	111351	111350	.021	.012	12-16	3-5
8	167436	111350	.016	.010	12.5-16.5	3-7
8*	157747*	26476	.016	.010	7-9	3-5
9	124843	111350	.016	.010	17-23	2-4
10-11	184466	167424	.016	.010	5-7	4-8
12-15	124843	111350	.016	.010	17-23	2-4
16	198400	127154 122181	.036	.020	7-9	5-7
17	159758	167424 122181	.036	.020	6-9	8-12
18	111331	111330	.021	.012	4-6.5	2.5-4
19	122532	111350	.016	.010	14-18	3-5
19*	124844	121059	.021	.012	8.5-10.5	2-3
20	111351	111350	.021	.012	12-16	3-5
20*	124843	111350	.016	.010	17-23	2-4
21	23714	145216	.013	.008	5-7	4.5-7.5
22-25	111334	111330	.016	.010	4-6	3.5-5.5
26	184466	167424	.016	.010	5-7	4-8
27	111334	111330	.016	.010	4-6	3.5
28	184466	167424	.016	.010	5-7	4-8-5
28-x	121877	26476	.016	.010	5-7	4-2-4
29-32	184466	167424	.016	.010	5-7	3-5

Continued on next page.

Continued from preceding page.

Machine Type 077
Wiring Diagram No. 193681

Relay Position Number	Relay Part Number	Relay Coil Number	Armature Core Airgap "Through"	Contact Adjustment "A" Gauge	Operating Time in Milliseconds	
					Pickup	Drop-out
33	121058	26476	.016	.010	4-6	4-10
34	167436	111350	.016	.010	125-165	3-7
35	121877	26476	.016	.010	5-7	4-8
36-x	111351	111350	.021	.012	12-16	3-5
37-x	184466	167424	.016	.010	5-7	4-8
38-x	111371	111370	.021	.012	19-26	3-5
39-40*	121058	26476	.016	.010	4-6	4-10
41*	121877	26476	.016	.010	5-7	4-8
42*	127679	26476	.016	.010	6-8	3-5
43-44*	111331	111330	.021	.012	4-6.5	2.5-4
45-46*	121058	26476	.016	.010	4-6	4-10
47*	157436	111350	.021	.012	12-16	4-6
48	127700	191225	.016	.010	7-9	2-4
49	153073	26476	.016	.010	6-8	2-5
50	128293	111350	.016	.010	13-18	3-5
51-52	125828	111330	.016	.010	5-7	1.5-5.5
53	121053	121059	.016	.010	4.5-6.5	5-7
54	206314	111350	.021	.012	(Thermal Delay)	
55	111374	111370	.016	.010	15-19	4-6.5
56-62	Unused					

Notes: (*) The asterisk indicates the relay used and its position when the Counting Device is installed.

(x) The x indicates the relay used and its position when Social Security circuit is installed.

Machine Type 089
Wiring Diagram No. 224000

1	124843	111350	.016	.010	17-23	2-4
2	123998	111370	.016	.010	21-27	3-5
3	124843	111350	.016	.010	17-23	2-4
4	111351	111350	.021	.012	12-16	3-5
5-7	127679	26476	.016	.010	6-8	3-5
8	178103	111350	.016	.010	13-17	1.5-5.5
9	124843	111350	.016	.010	17-23	2-4
10-11	127705	121059	.016	.010	5-7	4.5-6.5
12-15	124843	111350	.016	.010	17-23	2-4
16	198400	122181 127154	.036	.020	7-9	5-7
17	159758	122181 167424	.036	.020	6-9	8-12
18	111331	111330	.021	.012	4-6.5	2.5-4
12	127705	121059	.016	.010	5-7	4.5-6.5
128-	124843	111350	.016	.010	17-23	2-4
132	121877	26476	.016	.010	5-7	4-8
133	127700	26476	.016	.010	7-9	2-4
134+135	128293	111350	.016	.010	13-18	3-5

Continued on next page.

Continued from preceding page.

Machine Type 089
Wiring Diagram No. 224000

Relay Position Number	Relay Part Number	Relay Coil Number	Armature Core "Through"	Contact Adjustment "A" Gauge	Operating Time in Milliseconds	
					Pickup	Drop-out
24	125828	111330	.016	.010	5-7	1.5-5.5
25	124843	111350	.016	.010	17-23	2-4
26	121053	121059	.016	.010	4.5-6.5	5-7
27	153073	26476	.016	.010	6-8	2-5
28	127700	26476	.016	.010	7-9	2-4
29-32	Reserved					
33	121058	26476	.016	.010	4-6	4-10
34	167436	111350	.016	.010	12.5-16.5	7
35	121877	26476	.016	.010	5-7	4-8
36-38	127394	121059	.016	.010	5.5-7.5	6-8
39-48	Reserved					
49-51	214224	214222			13.5-16.5	2-3
52-53	Reserved					
54	206314	111350	.021	.012 (Thermal Delay)		

Machine Type 285
Wiring Diagram No. 173450-H

1-4	111331	111330	.021	.012	4-6.5	2.5-4
5-6	111334	111330	.016	.010	4-6	3.5-5.5
7-8	111331	111330	.021	.012	4-6.5	2.5-4
9-10	111334	111330	.016	.010	4-6	3.5-5.5
11	111331	111330	.021	.012	4-6.5	2.5-4
12	Reserved					
13-14	111331	111330	.021	.012	4-6.5	2.5-4
15	Reserved					
16-23	111331	111330	.021	.012	4-6.5	2.5-4
24-25	111334	111330	.016	.010	4-6	3.5-5.5
26	113600	113573	.016	.010	4-6	4-8
27	111334	111330	.016	.010	4-6	3.5-5.5
28-30	111331	111330	.021	.012	4-6.5	2.5-4
31-35	113600	113573	.016	.010	4-6	4-8
36-38	111331	111330	.021	.012	4-6.5	2.5-4
39	111334	111330	.016	.010	4-6	3.5-5.5
(1-16)						
Auto Ctrl.	113600	113573	.016	.010	4-6	4-8

Machine Type 402-403
Wiring Diagram No. 210201-C

1	121058	26476	.016	.010	4-6	4-10
2	182693	26476	.016	.010	7-9.5	3-5
3	128022	26476 128024	.028	.015	4-6	2-4
4	111351	111351	.021	.012	12-16	3-5
5-7	124843	111350	.016	.010	17-23	2-4
8	182693	26476	.016	.010	7-9.5	3-5

Continued on next page.

Continued from preceding page.

Machine Type 402-403
Wiring Diagram No. 210201-C

Relay Position Number	Relay Part Number	Relay Coil Number	Armature Core Airgap "Through"	Contact Adjustment "A" Gauge	Operating Time in Milliseconds	
					Pickup	Drop-out
9	157747	26476	.016	.010	7-9	3-5
10-11	182693	26476	.016	.010	7-9.5	3-5
12	157747	26476	.016	.010	7-9	3-5
13	127700	191225	.016	.010	7-9	2-4
14-15	124843	111350	.016	.010	17-23	2-4
16-18	182693	26476	.016	.010	7-9.5	3-5
19	127700	191225	.016	.010	7-9	2-4
20-23	121058	26476	.016	.010	4-6	4-10
24	127700	191225	.016	.010	7-9	2-4
25	121058	26476	.016	.010	4-6	4-10
26	111351	111351	.021	.012	12-16	3-5
27	121877	26476	.016	.010	5-7	4-8
28	127700	191225	.016	.010	7-9	2-4
29	Unused					
30	Unused					
31	182693	26476	.016	.010	7-9.5	3-5
32	121877	26476	.016	.010	5-7	4-8
33	127700	191225	.016	.010	7-9	2-4
34	124843	111350	.016	.010	17-23	2-4
35	123875	26476	.021	.012	5-8	5.5-6.5
36	111351	111351	.021	.012	12-16	3-5
37	127679	26476	.016	.010	6-8	3-5
38-39	222634	127154 122181	.036	.020	7-9	4-5
40	121877	26476	.016	.010	5-7	4-8
41	127700	191225	.016	.010	7-9	2-4
42	Unused					
43	121058	26476	.016	.010	4-6	4-10
44	124843	111350	.016	.010	17-23	2-4
45	182693	26476	.016	.010	7-9.5	3-5
46	127700	191225	.016	.010	7-9	2-4
47	122532	111350	.016	.010	14-18	3-5
48-49	124843	111350	.016	.010	17-23	2-4
50	121058	26476	.016	.010	4-6	4-10
51	111351	111351	.021	.012	12-16	3-5
52	121054	121059	.021	.012		
53	111351	111351	.021	.012	12-16	3-5
54-55	202800	(High Speed Relay)				
56	112627	(High Speed Relay)				
57	121877	26476	.016	.010	5-7	4-8
58	Unused					
59	Unused					
60-61	121877	26476	.016	.010	5-7	4-8
62-63	127700	191225	.016	.010	7-9	2-4
64-66	111351	111351	.021	.012	12-16	3-5
67-75	Unused					

Continued on next page.

Continued from preceding page.

Machine Type 402-403
Wiring Diagram No. 210201-C

Relay Position Number	Relay Part Number	Relay Coil Number	Armature Core Airgap "Through"	Contact Adjustment "A" Gauge	Operating Time in Milliseconds	
					Pickup	Drop-out
76	121058	26476	.016	.010	4-6	4-10
77	128022	26476 128024				
78	182693	26476	.016	.010	7-9.5	3-5
79	127700	191225	.016	.010	7-9	2-4
80	124843	111350	.016	.010	17-23	2-4
81	127700	191225	.016	.010	7-9	2-4
82	151688	145216	.016	.010	7-9	2-4
83-86	124843	111350	.016	.010	17-23	2-4
87	111351	111351	.021	.012	12-16	3-5
88	123875	26476	.021	.012	5-8	5.5-6.5
89-110	Unused					
111-150	122439	175236	.013	.008	5-7	7-12
151-200	Unused					
201-202	121058	26476	.016	.010	4-6	4-10
203	111351	111351	.021	.012	12-16	3-5
204	121877	26476	.016	.010	5-7	4-8
205	127700	191225	.016	.010	7-9	2-4
206	121058	26476	.016	.010	4-6	4-10
207	127700	191225	.016	.010	7-9	2-4
208	121058	26476	.016	.010	4-6	4-10
209	121877	26476	.016	.010	5-7	4-8
210-211	182693	26476	.016	.010	7-9.5	3-5
212	124843	111350	.016	.010	17-23	2-4
213	121877	26476	.016	.010	5-7	4-8
214-215	124843	111350	.016	.010	17-23	2-4
216	121058	26476	.016	.010	4-6	4-10
217	127050	26476	.016	.010	6.5-8.5	2-4
218-219	124843	111350	.016	.010	17-23	2-4
220	127679	26476	.016	.010	6-8	3-5
221	127700	191225	.016	.010	7-9	2-4
222	127679	26476	.016	.010	6-8	3-5
223	182693	26476	.016	.010	7-9.5	3-5
224-228	121058	26476	.016	.010	4-6	4-10
229	121877	26476	.016	.010	5-7	4-8
230	121058	26476	.016	.010	4-6	4-10
231-232	127679	26476	.016	.010	6-8	3-5
233	111351	111351	.021	.012	12-16	3-5
234-235	127700	191225	.016	.010	7-9	2-4
236	124843	111350	.016	.010	17-23	2-4
237	127679	26476	.016	.010	6-8	3-5
238	121058	26476	.016	.010	4-6	4-10
239	121877	26476	.016	.010	5-7	4-8
240	111351	111351	.021	.012	12-16	3-5
246-269	121058	26476	.016	.010	4-6	4-10

DUO RELAY CHARACTERISTIC CHART

Machine Type 405
Wiring Diagram No. 128450-S

Relay Position Number	Relay Part Number	Relay Coil Number	Armature Core Airgap "Through"	Contact Adjustment "A" Gauge	Operating Time in Milliseconds	
					Pickup	Drop-out
1	127679	26476	.016	.010	6-8	3-5
2	124981	111350	.021	.012	15-19	2.5-4.5
3	122532	111350	.016	.010	14-18	3-5
4	124843	111350	.016	.010	17-23	2-4
5	121058	26476	.016	.010	4-6	4-10
6	121877	26476	.016	.010	5-7	4-8
7	153073	26476	.016	.010	6-8	2-5
8	121058	26476	.016	.010	4-6	4-10
9	182693	26476	.016	.010	7-9.5	3-5
10	121841	113360	.016	.010	17-23	3-5
11	182693	26476	.016	.010	7-9.5	3-5
12	124843	111350	.016	.010	17-23	2-4
13	121877	26476	.016	.010	5-7	4-8
14	121058	26476	.016	.010	4-6	4-10
15	151688	145216	.016	.010	7-9	3.5-6
16	151688	145216	.016	.010	7-9	3.5-6
17	128022	26476 128024	.028	.015	4-6	2-4
18	280227	280225 122181	.028	.015	10-14	5-9
19	127700	191225	.016	.010	7-9	2-4
20	128299	128297 122181	.028	.015	6-8	3-6
21	111351	113350	.021	.012	12-16	3-5
22	157747	26476	.016	.010	7-9	3-5
23	121058	26476	.016	.010	4-6	4-10
24	124843	111350	.016	.010	17-23	2-4
25	128022	26476 128024	.028	.015	4-6	2-4
26	142368	127154 122181	.028	.015	5-7	6-10
27	127700	191225	.016	.010	7-9	2-4
28	157747	26476	.016	.010	7-9	3-5
29	127700	191225	.016	.010	7-9	2-4
30	128022	26476 128024	.028	.015	4-6	2-4
31	127700	191225	.016	.010	7-9	2-4
32	127700	191225	.016	.010	7-9	2-4
33	124843	111350	.016	.010	17-23	2-4
34	128022	26476 128024	.028	.015	4-6	2-4
35	124843	111350	.016	.010	17-23	2-4
36	128022	26476 128024	.028	.015	4-6	2-4
37	124843	111350	.016	.010	17-23	2-4
38	153073	26476	.016	.010	6-8	2-5
39	128022	26476 128024	.028	.015	4-6	2-4

Continued on next page.

Continued from preceding page.

Machine Type 405
Wiring Diagram No. 128450-S

Relay Position Number	Relay Part Number	Relay Coil Number	Armature Core Airgap "Through"	Contact Adjustment "A" Gauge	Operating Time in Milliseconds	
					Pickup	Drop-out
40	104951	26476 128024	.028	.015	4.5-7.5	2-4
41	128293	111350	.016	.010	13-18	3-5
42	127858	127154 122181	.028	.015	5.5-7.5	10-14
43	124843	111350	.016	.010	17-23	2-4
44	127700	191225	.016	.010	7-9	2-4
45	127050	26476	.016	.010	6.5-8.5	2-4
46	127700	191225	.016*	.010	7-9	2-4
47	128022	26476 128024	.028	.015	4-6	2-4
48	145215	145216	.016	.010	5-7	5-10
49	111354	111350	.016	.010	10-14	4.5-7.5
50	157436	111350	.021	.012	12-16	4-6
51	157747	26476	.016	.010	7-9	3-5
52	153073	26476	.016	.010	6-8	2-5
53	121058	26476	.016	.010	4-6	4-10
54	121058	26476	.016	.010	4-6	4-10
55	121058	26476	.016	.010	4-6	4-10
56	124842	26476	.016	.010	6.5-9	2-5
57	Unused					
58	127679	26476	.016	.010	6-8	3-5
59	121058	26476	.016	.010	4-6	4-10
60	153073	26476	.016	.010	6-8	2-5
61	127679	26476	.016	.010	6-8	3-5
62-65	124843	111350	.016	.010	17-23	2-4
66	283517	26476	.016	.010	5-7	6-8
67	121058	26476	.016	.010	4-6	4-10
68-70	124843	111350	.016	.010	17-23	2-4
71	Optional					
72	Optional					
73	182693	26476	.016	.010	7-9.5	3-5
74	124843	111350	.016	.010	17-23	2-4
75	283313	280225	.016	.010	6-8	2-4
76	153073	26476	.016	.010	6-8	2-5
77	182693	26476	.016	.010	7-9.5	3-5
78	121877	26476	.016	.010	5-7	4-8
79-81	122499	121059	.021	.012	6.5-8.5	2-4
82	128327	111330	.016	.010	5-7	2-3
83	111334	111330	.016	.010	4-6	3.5-5.5
X-R MCR	127619	153412(2)	.021	.012	4-6	5-9
90	Unused					
91	Unused					
92	Unused					
93	128022	26476 128024	.028	.015	4-6	2-4

Continued on next page.

Continued from preceding page.

Machine Type 405
Wiring Diagram No. 128450-S

Relay Position Number	Relay Part Number	Relay Coil Number	Armature Core Airgap "Through"	Contact Adjustment "A" Gauge	Operating Time in Milliseconds	
					Pickup	Drop-out
94	127679	26476	.016	.010	6-8	3-5
95	128022	26476 128024	.028	.015	4-6	2-4
96	121877	26476	.016	.010	5-7	4-8
97	128022	26476 128024	.028	.015	4-6	2-4
98	127700	191225	.016	.010	7-9	2-4
99	128022	26476 128024	.028	.015	4-6	2-4
100	127700	191225	.016	.010	7-9	2-4
101	128022	26476 128024	.028	.015	4-6	2-4
102	127700	191225	.016	.010	7-9	2-4
103	128022	26476 128024	.028	.015	4-6	2-4
104	127700	191225	.016	.010	7-9	2-4
105	128022	26476 128024	.028	.015	4-6	2-4
106	127700	191225	.016	.010	7-9	2-4
107	128022	26476 128024	.028	.015	4-6	2-4
108	127700	191225	.016	.010	7-9	2-4
109	128022	26476 128024	.028	.015	4-6	2-4
110	127700	191225	.016	.010	7-9	2-4
111	128022	26476 128024	.028	.015	4-6	2-4
112	127700	191225	.016	.010	7-9	2-4
113	128022	26476 128024	.028	.015	4-6	2-4
114	127700	191225	.016	.010	7-9	2-4
115	128022	26476 128024	.028	.015	4-6	2-4
116	127700	191225	.016	.010	7-9	2-4
117-120	124843	111350	.016	.010	17-23	2-4
121-128	Unused					
129-168	122439	175236	.016	.010	5-7	7-12
169-175	122499	121059	.021	.012	6.5-8.5	2-4
176 (Odd)	124843	111350	.016	.010		
177-225 (Even)	121837	111360	.021	.012	17-23	3-5
178-256	121841	111360	.016	.010	17-23	3-5
257	122499	121059	.021	.012	6.5-8.5	2-4
258	122499	121059	.021	.012	6.5-8.5	2-4
259	124844	121059	.021	.012	8.5-10.5	2-3
260	127705	121059	.016	.010	5-7	4.5-6.5

Continued on next page.

Continued from preceding page.

Machine Type 405
Wiring Diagram No. 128450-S

Relay Position Number	Relay Part Number	Relay Coil Number	Armature Core Airgap "Through"	Contact Adjustment "A" Gauge	Operating Time in Milliseconds	
					Pickup	Drop-out
261-276	127705	121059	.016	.010		
277-292	124842	26476	.016	.010	6.5-9	2-5
293	111354	111350	.016	.010		
294-297	122532	111350	.016	.010	14-18	3-5
298	124843	111350	.016	.010	17-23	2-4
299	124843	111350	.016	.010	17-23	2-4
300	124843	111350	.016	.010	17-23	2-4
301-302	111374	111370	.016	.010	15-19	4-5
303-305	121841	111360	.016	.010	17-23	3-5
306	111374	111370	.016	.010	15-19	4-5
307	121841	111360	.016	.010	17-23	3-5
308	111374	111370	.016	.010	15-19	4-5
309-312	121841	111360	.016	.010	17-23	3-5
313	111374	111370	.016	.010	15-19	4-5
314	111374	111370	.016	.010	15-19	4-5
315-317	121841	111360	.016	.010	17-23	3-5
318	111374	111370	.016	.010	15-19	4-5
319	121841	111360	.016	.010	17-23	3-5
320	111374	111370	.016	.010	15-19	4-5
321-324	121841	111360	.016	.010	17-23	3-5
325	157747	26476	.016	.010	7-9	3-5
326	Optional					
327	128022	26476 128024	.028	.015	4-6	2-4
328	127679	26476	.016	.010	6-8	3-5
329	124843	111350	.016	.010	17-23	2-4
330	124843	111350	.016	.010	17-23	2-4
331	128022	26476 128024	.028	.015	4-6	2-4
332	127679	26476	.016	.010	6-8	3-5
333	124843	111350	.016	.010	17-23	2-4
334	124843	111350	.016	.010	17-23	2-4
335	128022	26476 128024	.028	.015	4-6	2-4
336	127679	26476	.016	.010	6-8	3-5
337	124843	111350	.016	.010	17-23	2-4
338	124843	111350	.016	.010	17-23	2-4
339	128022	26476 128024	.028	.015	4-6	2-4
340	127679	26476	.016	.010	6-8	3-5
341	124843	111350	.016	.010	17-23	2-4
342	124843	111350	.016	.010	17-23	2-4
343	153073	26476	.016	.010	6-8	2-5
344	153073	26476	.016	.010	6-8	2-5
345	121058	26476	.016	.010	4-6	4-10
346	111354	111350	.016	.010	10-14	4.5-7.5

Continued on next page.

Continued from preceding page.

Machine Type 405
Wiring Diagram No. 128450-S

Relay Position Number	Relay Part Number	Relay Coil Number	Armature Core Airgap "Through"	Contact Adjustment "A" Gauge	Operating Time in Milliseconds	
					Pickup	Drop-out
347	127679	26476	.016	.010	6-8	3-5
348	127705	121059	.016	.010	5-7	4.5-6.5
349	121877	26476	.016	.010	5-7	4-8
350	121877	26476	.016	.010	5-7	4-8
351	127679	26476	.016	.010	6-8	3-5
352	127700	191225	.016	.010	7-9	2-4
353	111351	111350	.021	.012	12-16	3-5

Machine Type 513
Wiring Diagram No. 184300-Q

1	124843	111350	.016	.010	17-23	2-4
2	127700	191225	.016	.010	7-9	2-4
3-4	124843	111350	.016	.010	17-23	2-4
5	111374	111370	.016	.010	15-19	4-6.5
6-7	124843	111350	.016	.010	17-23	2-4
8	111371	111370	.021	.012	19-26	3-5
9	122532	111350	.016	.012	14-18	3-5
10	124842	26476	.016	.010	6.5-9	2-5
11-12	124843	111350	.016	.010	17-23	2-4
13	111351	111350	.021	.012	12-16	3-5
14	140461	167424 122181	.028	.015	6.5-9	5-9
15	157747	26476	.016	.010	7-9	3-5
16-17	111374	111370	.016	.010	15-19	4-6.5
18-19	121877	26476	.016	.010	5-7	4-8
21-22	124843	111350	.016	.010	17-23	2-4
23	122532	111350	.016	.010	14-18	3-5
24	111371	111370	.021	.012	19-26	3-5
25	124843	111350	.016	.010	17-23	2-4
28	111351	111350	.021	.012	12-16	3-5
33-34	127700	191225	.016	.010	7-9	2-4
35-36	124843	111350	.016	.010	17-23	2-4
37	111371	111370	.021	.012	19-26	3-5
38-39	127700	191225	.016	.010	7-9	2-4
40-41	124843	111350	.016	.010	17-23	2-4
42	111371	111370	.021	.012	19-26	3-5
43-56	121842	111350	.021	.012	13-17	3-6
65-78	184466	167424	.016	.010	5-7	4-8
87	127858	127154 122181	.028	.015	5.5-7.5	10-14
88	111351	111350	.021	.012	12-16	3-5
89	142368	127154 122181	.028	.015	5-7	6-10
90						
91-108	124843	111350	.016	.010	17-23	2-4
109-128	184466	167424	.016	.010	5-7	4-8
Cabinet (Right rear)	206314	111350	.021	.012	(Thermal Delay Relay)	

DUO RELAY CHARACTERISTIC CHART

Machine Type 519

Wiring Diagram No. 206200 — 206219 — 206213

Relay Position Number	Relay Part Number	Relay Coil Number	Armature Core Airgap "Through"	Contact Adjustment "A" Gauge	Operating Time in Milliseconds	
					Pickup	Drop-out
1	124843	111350	.016	.010	17-23	2-4
2	127700	191225	.016	.010	7-9	2-4
3-4	124843	111350	.016	.010	17-23	2-4
5	111374	111370	.016	.010	15-19	4-6.5
6	124843	111350	.016	.010	17-23	2-4
7	111374	111370	.016	.010	15-19	4-6.5
8-9-10	124843	111350	.016	.010	17-23	2-4
11	111371	111370	.021	.012	19-26	3-5
12	122532	111350	.016	.010	14-18	3-5
13-14	111371	111370	.021	.012	19-26	3-5
15	127679	26476	.016	.010	6-8	3-5
16-17	111371	111370	.021	.012	19-26	3-5
18	127700	191225	.016	.010	7-9	2-4
19-22	124842	111360	.016	.010	6.5-9	2-5
23	Spare					
24	111351	111350	.021	.012	12-16	3-5
25	124843	111350	.016	.010	17-23	2-4
26	178103	111350	.016	.010	13-17	1.5-5.5
27	121877	26476	.016	.010	5-7	4-8
28	Open					
29-30-31	121877	26476	.016	.010	5-7	4-8
32	111371	111370	.021	.012	19-26	3-5
33	111354	111350	.016	.010	10-14	4.5-7.5
34-35	121877	26476	.016	.010	5-7	4-8
36	111371	111370	.021	.012	19-26	3-5
37-42	Spare					
43-44	127700	191225	.016	.010	7-9	2-4
45-46	124843	111350	.016	.010	17-23	2-4
47-48	127700	191225	.016	.010	7-9	2-4
49-50	124843	111350	.016	.010	17-23	2-4
51-52	127700	191225	.016	.010	7-9	2-4
53-54	124843	111350	.016	.010	17-23	2-4
55-56	127700	191225	.016	.010	7-9	2-4
57-78	124843	111350	.016	.010	17-23	2-4
79-81	157436	111350	.021	.012	12-16	4-6
82	Spare					
83	111371	111370	.021	.012	19-26	3-5
84-85	124843	111350	.016	.010	17-23	2-4
86	Spare					
87	121841	111360	.016	.010	17-23	3-5
88	127498	122716	.016	.010	3.5-5.5	7-9
89	111371	111370	.021	.012	19-26	3-5
90	142368	127154 122181	.028	.015	5-7	6-10
91	124843	111350	.016	.010	17-23	2-4

Continued on next page.

Continued from preceding page.

Machine Type 519
Wiring Diagram No. 206200 — 206219 — 206213

Relay Position Number	Relay Part Number	Relay Coil Number	Armature Core Airgap "Through"	Contact Adjustment "A" Gauge	Operating Time in Milliseconds	
					Pickup	Drop-out
92-93	111354	111350	.016	.010	10-14	4.5-7.5
94	111351	111350	.021	.012	12-16	3-5
95	121058	26476	.016	.010	4-6	4-10
96	111354	111350	.016	.010	10-14	4.5-7.5
97	128022	26476 128024	.028	.015	4-6	2-4
98	127009	127154 122181	.028	.015	3-5	10-17
(Odd)						
99-137	121877	26476	.016	.010	5-7	4-8
(Even)						
100-138	283517	26476	.016	.010	5-7	6-8
139	134839	145216	.021	.012	10-12	5-7
140	145215	145216	.016	.010	5-7	5-10
141	111351	111350	.021	.012	12-16	3-5
142	121058	26476	.016	.010	4-6	4-10
143	111354	111350	.016	.010	10-14	4.5-7.5
144	121058	26476	.016	.010	4-6	4-10
145	145215	145216	.016	.010	5-7	5-10
146	Spare					
147	121058	26476	.016	.010	4-6	4-10
148	111374	111370	.016	.010	15-19	4-6.5
149-158	Spare					
163	111351	111350	.021	.012	12-16	3-5
164	121058	26476	.016	.010	4-6	4-10
165	111354	111350	.016	.010	10-14	4.5-7.5
166	121877	26476	.016	.010	5-7	4-8
167	111354	111350	.016	.010	10-14	4.5-7.5
168	121877	26476	.016	.010	5-7	4-8
169	Spare					
(Even)						
170-188	121877	26476	.016	.010	5-7	4-8
(Odd)						
171-189	283517	26476	.016	.010	5-7	6-8
Rear Cabinet	206314	111350	.021	.012	(Thermal Delay)	

Machine Type 552
Wiring Diagram No. 161561-N

1 to 3	111354	111350	.016	.010	10-14	4.5-7.5
--------	--------	--------	------	------	-------	---------

Machine Type 601
Wiring Diagram No. 107871-K

Duo						
1	117374	117370	.016	.010	18-24	3-7
2	117371	117370	.016	.010	22-28	3-5

Continued on next page.

Continued from preceding page.

Machine Type 601.

Wiring Diagram No. 107871-K

Relay Position Number	Relay Part Number	Relay Coil Number	Armature Core Airgap "Through"	Contact Adjustment "A" Gauge	Operating Time in Milliseconds	
					Pickup	Drop-out
3	127050	26476	.016	.010	6.5-8.5	2-4
4	117374	117370	.016	.010	18-24	3-7
5	121841	111360	.016	.010	17-23	3-5
6 to 9	117371	117370	.016	.010	22-28	3-5
10	121843	111350	.021	.010	14-18	2-4
11	121877	26476	.016	.010	5-7	4-8
12	128293	111350	.016	.010	13-18	3-5
13	157747	26476	.016	.010	7-9	3-5
14	117374	117370	.016	.010	18-24	3-7
15	117371	117370	.016	.010	22-28	3-5
16	117374	117370	.016	.010	18-24	3-7
17	127050	127050	.016	.010	6.5-8.5	2-4

Machine Type 602

Wiring Diagram No. 205951

1001	178103	111350	.016	.010	13-17	1.5-5.5
1002	129036	121059	.021	.012	7-9	3-5
1003	124843	111350	.016	.010	17-23	2-4
1004	111351	111350	.021	.010	12-16	3-5
1005	153073	26476	.016	.010	6-8	2-5
1006	122532	111350	.016	.010	14-18	3-5
1007	124843	111350	.016	.010	17-23	2-4
1008	111371	111370	.021	.010	19-26	3-5
1009	124981	111350	.021	.010	15-19	2.5-4.5
1010	111374	111370	.016	.010	15-19	4-6.5
1011	111354	111350	.016	.010	10-14	4.5-7.5
1012	178103	111350	.016	.010	13-17	1.5-5.5
1013	111371	111370	.021	.010	19-26	3-5

Machine Type 801

Wiring Diagram No. 103575-A

1	167436	111350	.016	.010	12.5-16.5	3-7
2	111371	111370	.021	.012	22-28	3-5
3	128428	280225 122181	.028	.015	10-14	5-9
4-5	111371	111370	.021	.012	22-28	3-5
6	111374	111370	.016	.010	15-19	4-6.5
7	111351	111350	.021	.012	12-16	3-5
8	101959	127154 128024	.021	.012	Latch Type Relay	
9	111351	111350	.021	.012	12-16	3-5
10	128428	280225 122181	.028	.015	10-14	5-9
11	124843	111350	.016	.010	17-23	2-4

HIGH SPEED RELAY (COLLATOR)

THIS RELAY, as the name implies, is designed to operate very rapidly; the pickup time ranging from 2 to 2.5 milliseconds. It is used in the 40-volt circuits of the collator, Type 077 and is designed to be operated by short or momentary impulses only. This relay controls only one set of contact points which may be either N/O or N/C. One of these contact straps also serves as the armature of the relay. This is a pluggable type relay and may be readily removed from the machine for inspection and adjustment without removing any wires or screws.

Relay Adjustment (Figure 11)

Normally Closed Contact Relay

1. Upper contact strap must have sufficient tension to lay snugly against its support without assistance from adjusting screw.
2. Lower contact strap must be so formed that its tension tends to hold the points closed. With a gram gauge applied and a read-

ing of 15 grams, the points should just open.

3. By means of the adjusting screw (1) set armature-core air gap for a .012" clearance.

Normally Open Contact Relay

1. Upper contact strap should be formed so that tension holds strap against adjusting screw. With gram gauge applied and a scale reading of 20 to 30 grams, this strap should just clear the adjusting screw.
2. Adjust for an armature (upper contact strap) core air gap of .012" \pm .002". Use adjusting screw to obtain this clearance.
3. Adjust contact point gap by bending lower contact strap supports for the following conditions:
 - a. Insert a .006" thickness gauge in the armature-core gap, and with the armature held attracted there should be a minimum clearance between the the points.
 - b. Insert a .005" thickness gauge in the armature-core gap. With armature attracted the points should just close.

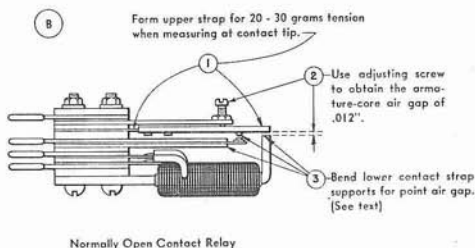
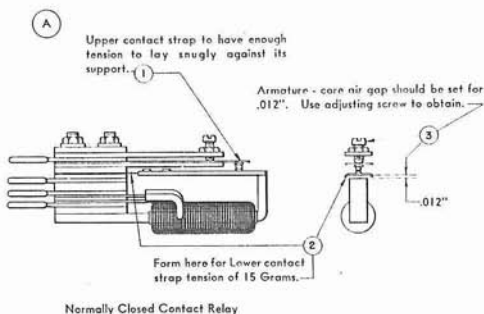

Figure 11. High Speed Relay (Collator)

HIGH SPEED RELAY CHARACTERISTIC CHART

Machine Type 077

Relay Position	Relay Part Number	Relay Coil Number	Armature Core Airgap	Contact	Operating Time in Milliseconds	
					Pickup	Drop-out
1-2-3	166739	166743	.012-.002	N/O	2-2.5	1-4
4	166740	166743	.012	N/C	2-2.5	1-4

SLATE BASE RELAY

THE SLATE BASE relay is one of IBM's oldest relays and is used in those applications requiring high speed operation. Its principal application today is in the Types 075 and 080 sorting machines.

It is designed to operate on 110 volts DC and has an operating pick-up speed of 1 to 2 milliseconds. Drop-out time is approximately 2 MS.

These relays are supplied in three general classifications; namely,

1. Three Terminal Post
2. Four Terminal Post
3. Five Terminal Post

The 3-post relay is applicable where the N/O contact points and the coil are wired into the same circuit. An example of its use is the brush relay of the Type 080.

The 4-post relay is used where the coil is wired into one circuit and the

contact points; either N/O or N/C are used to control an entirely separate circuit. An example of the application of this type relay is the sorting control relay of the Type 075 machine.

The 5-post relay may consist of a set of transfer contact points, requiring three terminal posts and a coil requiring 2 posts. Another type of 5-post relay is equipped with a pick coil, wired into one circuit while a hold coil and a N/O contact are applied to another circuit. The transfer setup relay of Type 075 machine is an example.

Adjustments (Figure 12)

1. Check pivot screws for wear. Replace if they are worn elliptical. Adjust pivot screws to align contact points and provide a free moving armature, with a minimum of end play. Adjust pivot screws to hold armature laterally so its point

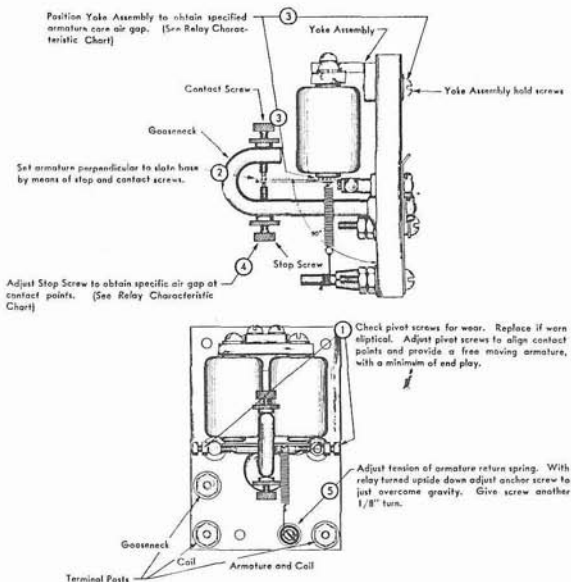

Figure 12. Slate Base Relay

SLATE BASE RELAY CHARACTERISTIC CHART

Machine Type	Relay Position Name	Relay Part Number	Number of Posts	Armature-Core Airgap	Contact Point Airgap
075	Brush Ctrl	18545	4	.005"	.008"
075	Sort Ctrl	144222	4	.012"	1/32"
075	C.L. Hold	21824	3	.008"	.008"
075	Trans. Setup	153016	5	.005"	.005"
075	9-12 Ctr-Ctrl	21824	3	.005"	.005"
080	Brush Ctrl	11597	3	.005"	.008"
080	Card Ctrl	21824	3	.008"	.008"
075-080	MCS #1	21821	4	.005"	.005"
075-080	MCS #2	21824	3	.008"	.008"
075-080	MCS #3	118098	4	.005"	.005"

lines up with the contact point in the upper or lower screw. Back off one pivot screw 1/6 turn from finger tight position and tighten lock nuts.

2. Set armature perpendicular to the slate base. Hold it in this position by means of the contact screw and stop screw. Tighten lock nut on contact screw only at this time.
3. With the armature perpendicular to the base loosen the yoke holding screws and position the yoke assembly to obtain the specified clearance between the armature and cores. Specific airgap dimensions for the various relays may be secured from the slate base relay characteristics chart. Tighten yoke holding screws.
4. Adjust stop screw downward to obtain the specified air gap between contact points (see Slate Base Relay Characteristic Chart). Tighten lock nut.
5. Adjust the tension of the armature return spring by turning anchor screw just to overcome gravity with relay turned upside down. Give anchor screw approximately 1/8 turn more.

The above adjustments on this type relay are identical for 3-, 4- and 5-post units, with the exception of the armature-core and contact point airgaps.

These dimensions vary with the application of the relay and are shown in the chart above.

HIGH SPEED RELAY No. 202800

THIS HIGH SPEED relay may be considered a modern version of the slate base relay. It is designed primarily to meet high speed operation require-

ments, while its physical dimensions permit it to be mounted in the same amount of space allotted to a duo relay.

The unit consists of a single pair of contact points, either N/O or N/C, a gooseneck contact and armature stop assembly and a pair of magnets #216535. The armature is light in weight and operates on conical-shaped pivots, both tending to facilitate fast operation. The relay is designed to operate in 40-volt circuits and has a pickup time of 1-2 MS and a drop-out time of approximately 2 MS. The N/C points must open in 1 millisecond.

Adjustments (Figure 13)

1. Core faces should be parallel to each other and should be free of burrs and roughness. Stone faces to make corrections.
2. The armature pivot screws should fit relatively tight in the tapped holes in the pivot screw ears of the yoke assembly. This is necessary to prevent these screws from moving during operation and thus destroy the adjustment. To provide a tighter clamping action on the pivot screw, remove the screw and drive the two sides of the split screw ear of the yoke assembly closer together.
3. Adjust for vertical alignment of contact points by raising or lowering the armature in relation to the pivot shaft. With points aligned, armature sides should be parallel to the core faces. Lock holding screw securely when adjustment is complete.
4. Apply a small amount of IBM lubricant 17 to the armature pivots before adjusting. Adjust

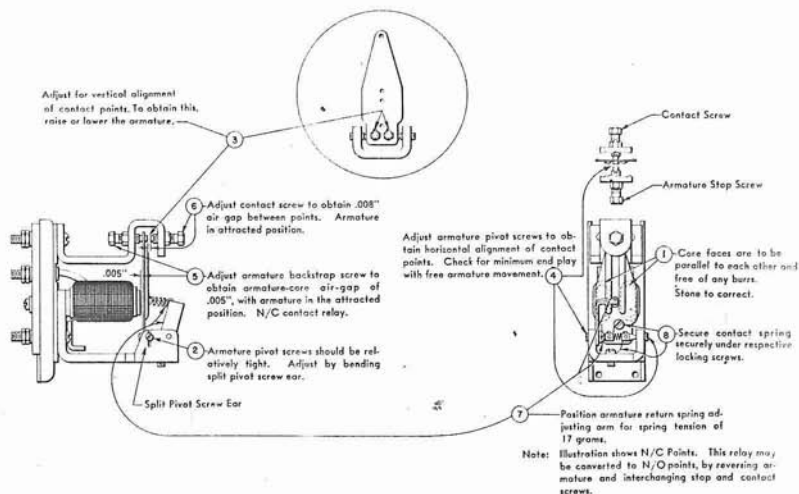

Figure 13. High Speed Relay No. 202800

the armature pivot screws to obtain the horizontal alignment of the contact points. They should also be adjusted for minimum end play of the pivot shaft and still maintain absolute freedom of armature movement.

5. Adjust stop screw (N/C point relay) for a .005" air gap between armature and core with armature in the energized position. Bend armature to secure this same clearance across entire core face.
6. Adjust contact screw for an .008" air gap between points with armature in the energized position (N/C point relay).
7. Position the armature return spring adjusting arm for a spring tension of 17 grams. Do not overload with spring tension.
8. Be sure the ends of contact spring on the armature pivot shaft are securely fastened under the respective screws of the armature and yoke.

Note: This relay may be converted to a make type contact by reversing the armature and interchanging the adjustable stop and contact screws.

HEAVY DUTY RELAYS

HEAVY DUTY relays are normally used in those circuits drawing a comparatively high current usually in excess of 5 amperes. They are gener-

ally applied to all the motor circuits of the various machines; also in the zero button magnet circuit of the Type 285. Large tungsten contact points are employed in order to withstand the destructive arc which results when these circuits are opened.

There are two general types of heavy duty relays:

1. GE Heavy Duty Relays
2. IBM Unit Type Relays (DC and AC). The following table indicates the various relays available, the part number, and the voltages and frequencies of each:

INTERNATIONAL UNIT TYPE RELAY CHARACTERISTIC CHART

Relay Part Number	Relay Coil Number	Volts - Cycles
72912	72885	3V-DC
72913	72886	6V-DC
72914	72887	12V-DC
76725	76669	24V-DC
72915	72888	40V-DC
72916	72889	48V-DC
72918	72890	96-110V-DC
72893	72876	12V-60C
72751	72755	24V-60C
72894	72877	48V-60C
72895	72878	110V-60C
72896	72879	220V-50-60C
72898	72881	24V-25C
72899	72882	48V-25C
72900	72883	110V-25C
72901	72884	220V-25C

These relays are designed to operate in circuits of varying voltages as indicated in the chart (page 31).

GE Relay Adjustments

GE relays were used on IBM equipment in the past and are still to be found in many of the older machines in the field. When replacement is necessary, IBM unit relays are substituted.

These relays should require very little adjustment other than to see that the armatures work freely and that the points are clean. The armature return spring should have sufficient tension to insure proper opening

of the points. A check should be made to be sure the points make squarely and simultaneously.

Unit Type Relay Adjustments

The following adjustments are recommended when the International Unit Type Heavy Duty Relays used on miscellaneous accounting machines are adjusted. Number of adjustment refers to sequence of adjustment and to Figure 14. Adjustment 1 is only made on alternating current unit type relays. Adjustment 2 through 4 refer to both alternating current and direct current unit type relays.

The adjustments are as follows:

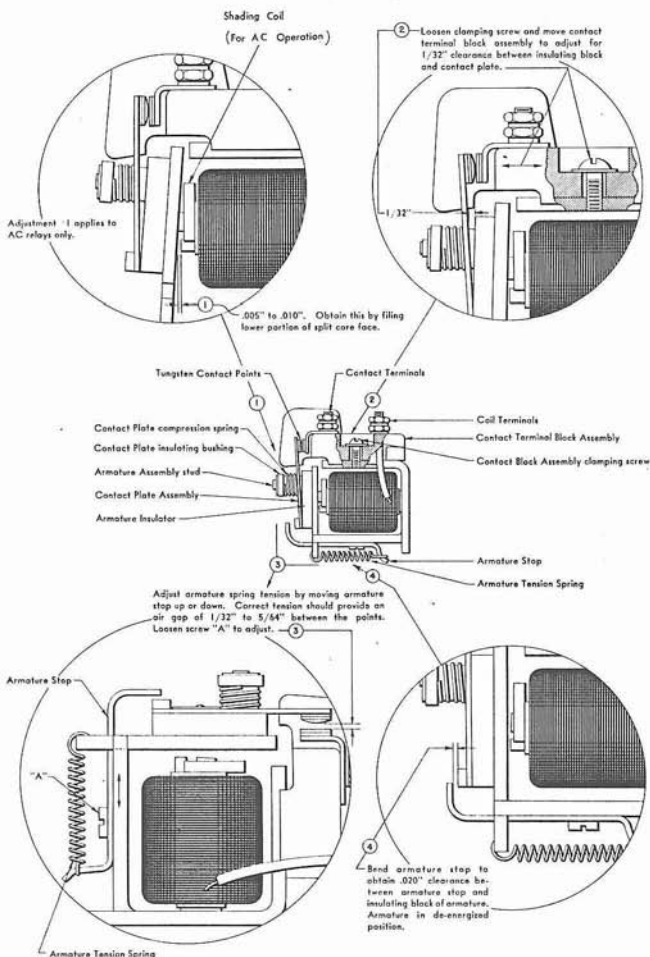

Figure 14. IBM Unit Type Relay

1. On alternating current unit type relays there should be .005" to .010" clearance between the armature and the lower part of the split core face when the armature is fully attracted. This clearance is obtained by filing.
2. With the armature attracted there should be 1/32" clearance between the insulating block on the armature and the contact plate. Adjust by loosening clamping screw and moving the contact terminal block assembly. After getting correct lift of the contact plate, check to insure that the contacts close simultaneously so that the arc will be evenly distributed.
3. With the relay in a horizontal position the armature should balance with a contact air gap of 1/32" to 5/64". Adjust by loosening the armature stop retaining screw A and moving armature stop to obtain correct armature spring tension. A 100 to 150 gram weight applied at the point should seal the armature.
4. With the relay in operating position and the contacts fully open there should be a clearance no greater than .020" between the insulating block on the armature and the armature stop.

Note: When relays are used on alternating current, a characteristic hum is present under some conditions. However, the relay should not hum when proper current is applied. If the relay does hum, the armature is not seating flat on the yoke and the core. The upper part of split core face and the armature pivot points should be checked for burrs or foreign material.

Shading Coil (Figure 14)

Heavy duty relays operated from an AC voltage source are equipped with a *shading coil*. This coil consists of a heavy single, closed turn and is mounted in the split core (armature end) of the relay. Its purpose is to split the phase and thus produce a two-phase effect which will prevent the armature from dropping away from the core during the time that the alternating current in the relay coil circuit approaches and passes through the zero value of the sine wave. The tendency of the armature

to drop back to the de-energized position at zero time, followed by the re-energization of the relay coil as the current builds up in the opposite direction would cause a vibrating or chattering armature action.

During the cycle when the current is dropping from its maximum value to the zero value, the magnetic lines of force cutting across the shading coil cause an induced voltage in the shading coil. Current flowing in the single turn shading coil produces a magnetic field which will provide the necessary holding or sealing action for the armature, until the voltage and current builds up in the opposite direction to a point where the relay coil will again be energized. Thus, the shading coil functions to provide a continuous holding effect on the armature and overcomes the tendency of the armature to fall to its de-energized position.

Note: It is important that conditions in adjustment 1 be adhered to in order to eliminate a noisy chattering relay operation.

WIRE CONTACT RELAY

THE WIRE contact relay was developed to meet the need for a compact high speed relay for use on 40 volts DC. The unit is available in three sizes: 4, 6 and 12 transfer contact, single and double coil. The use of transfer contacts provides a flexible capacity which eliminates the need for several different relay assemblies having various contact combinations. The relay is pluggable, employing a terminal moulding connector which permits completion of wiring before relays are installed in a machine. The unit is readily removable for inspection or replacement and does not require removal of screws or wires. The wire contacts were not designed for circuit interruption, but the silver alloy now in use will stand some arcing. Figure 15 illustrates the component parts of a 4-position non-latch type relay.

Relay Terminal Wiring

The relay contacts are numbered from left to right facing the yoke end (Figure 15). When a holding contact is required, contact number one should be used. The common side of a wire contact relay coil is the side on which the high numbered contact is located. When wiring into the ter-

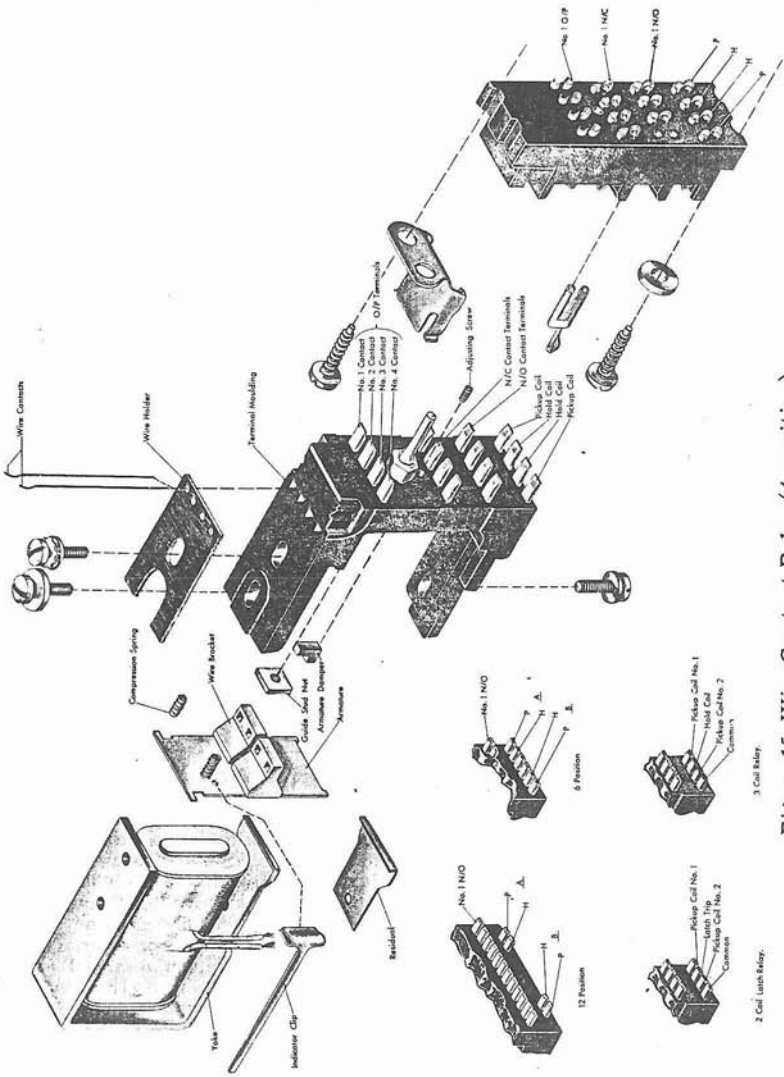

Figure 15. Wire Contact Relay (4-position).

3 Coil Entry.
2 Coil Latch Relay.

minimal moulding, care should be exercised to prevent excessive pressure which may result in cracking or breaking the terminal moulding. The spacing between plugs in adjacent

contact positions is sufficient when the plugs are inserted straight and not bent to one side. No more than two wires may be wired to each terminal.

WIRE CONTACT RELAY CHARACTERISTIC CHART

Relay Part Number	Relay Size	Relay Coil Number	Coil Use	Coil Color *	PU Time M/S 40 Volts	Duty Cycle (Percentage)	
196206	4	198881	PU		6.0	100	
196207	4	198884	PU		6.0	100	
196208	4	198887	PU		6.0	100	
			HRH	red	8.0	100	
104753	4	186693	HSPU	blue	4.5	50	
			Hold		6.5	100	
186696	4	186693	HSPU-1	blue	4.5	50	
			186699	HSPU-2	blue	4.5	25
			186259	Hold		8.0	100
186256	4	186259	PU		*6.0	100	
			186259	Hold	*8.0	100	
			186260	PU-I	blue	*6.0	25
186685	4	186708	PU		6.0	30	
			186707	Latch		6.0	50
186247	4	186249	PU-1		6.0	50	
			PU-2		6.0	50	
			186707	Latch		6.0	50
196196	6	198882	PU		6.0	100	
196197	6	198885	PU-1		6.0	100	
			PU-2		6.0	100	
196198	6	198888	PU		6.0	100	
			HRH	red	8.0	100	
			HSPU	blue	4.5	25	
107558	6	107559	HSPU	blue	4.5	25	
107560	6	107566	HSPU	blue	4.5	25	
			Hold		6.0	100	
			PU		6.0	50	
186686	6	186255	Latch		6.0	50	
			186253	PU		6.0	100
196186	12	198883	PU		6.0	100	
196187	12	198886	PU-1		6.0	100	
			PU-2		6.0	100	
196188	12	198889	PU		6.0	100	
			HRH	red	8.0	100	
107556	12	107557	HSPU	blue	4.5	25	
108388	12	108389	HSPU	blue	4.5	25	
			Hold		14.0	100	

Note: The Drop-Out time for each of the above relays is to be considered as being 4 milliseconds, when a 40-volt potential is applied to the coils.

Legend

PU—Pickup Coil.

(Suffix 1 or 2 indicates PU coil 1 or 2)

PU-I—The pick coil is on the yolk for maximum isolation.

HRH—High Resistance Hold Coil.

Hold—Hold coil only.

HSPU—High Speed Pickup.

Latch—Unlatching coil.

*—Maximum pickup time listed above is for repetitive cycles of operation on the same coil. Increase the pickup time 3 MS if the coil receives single impulses, alternating from coil to coil.

Duty Cycle—Percentage of time the relay is designed to operate.

Non-Latch Type Relay Adjustments

The relay adjustments are listed in the order in which they should be made. They are given for the 4-position relay with an indication of the variations for the 6-position and 12-position relays. The test device should be used to check these adjustments as explained under *Use of Relay Test Device*.

1. Figure 16. Contact air gap is machined to $.025" \pm .001"$ and should not be adjusted. Any attempt to change this gap will result in an out-of-parallel condition and prevent proper contact in all positions. Check for clearance of $.003"$ to $.005"$ between the armature and core with armature attracted. Adjustment for this clearance involves forming the center section of the armature. The residual must be flat against the face of the yoke, and the armature and core must be free of dirt or metal chips to insure good operation. Position the yoke to provide approximately $.050"$ travel at free end of armature. This is merely a starting point and may be changed to satisfy subsequent adjustments.

2. Figure 17. With no wire tension on the armature, check the pressure exerted by the compression spring. This should be 7 to 15 grams, measured at the free end of the armature.

3. Figure 18. The contact wires should be inspected to insure that they are positioned near the center of the contacts (Insert, Figure 18). Armature end shake must not permit the wires to reach the edge of the contacts, but the armature pivot must be free.

4. Figure 18. Adjust tension on the contact wires by shifting the wire holder so that a 50-gram pressure applied at the center of the free end of the armature just moves the wires away from the contacts on the normally closed side. The 6- and 12-position relays require a 70 and a 130-gram pressure, respectively.

5. Figure 19. Adjust the magnet yoke assembly so that with a $.010"$ thickness gauge between the armature and yoke at the free end of the armature, and the armature attracted, all con-

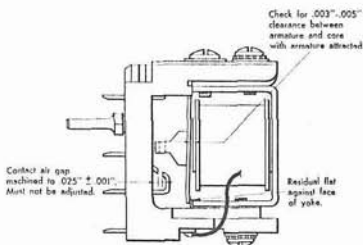

Figure 16

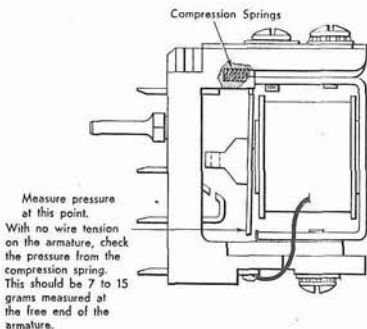

Figure 17

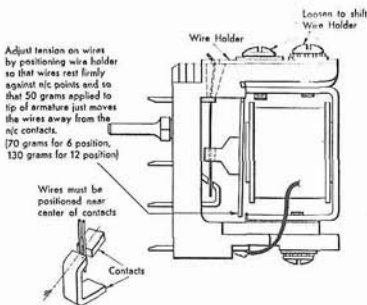

Figure 18

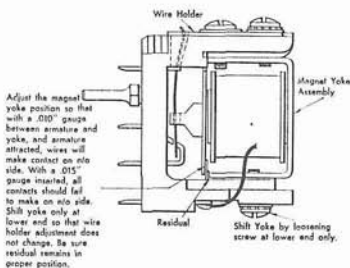

Figure 19

tact wires make contact on the normally open side. With a .015" gauge between armature and yoke and the armature attracted, none of the wires are to make contact on the normally open side. This adjustment is obtained by shifting the yoke assembly at the lower end only so that the wire holder adjustment does not change. If it is necessary to loosen the entire yoke to correct an out-of-parallel condition, the wire holder will have to be re-positioned for proper wire tension. Be sure the residual remains in the proper position.

- Figure 20. The damper screw should be adjusted to allow .003" to .005" movement between the vinylite damper and the wire bracket before the wire bracket can move any contact wire. If the screw is loosened, the vinylite damper must be pressed back into the moulding before checking the clearance between the damper and the wire bracket. Once adjusted at the factory, the damper screw is sealed with cement #198896.

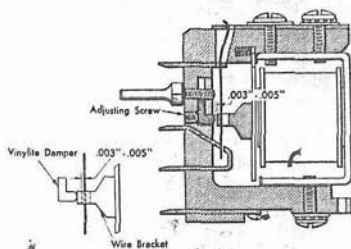

Figure 20

Latch Type Relay Adjustments

- Figure 21. Contact air gap is machined to $.024'' \pm .001''$ and should not be adjusted. Any attempt to change this gap will result in an out-of-parallel condition and prevent proper contact in all positions. Check for a clearance of .003" to .005" between the armature and core with armature attracted. Adjustment for this clearance forming the center section of the armature. The residual must be flat against the face of the yoke, and the armature and core must be free of dirt or metal chips to insure good operation. Position the yoke to provide approximately .050" travel at the free end of armature. This is merely a starting point and may be changed to satisfy subsequent adjustments.
- Figure 22. With the contact wires removed, the two relay armature pivot springs must exert 7 to 15 grams pressure against the relay armature at its free end.
- Figure 23. With the contact wires in place see that they are

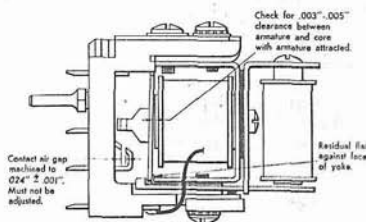

Figure 21. Adjustment 1

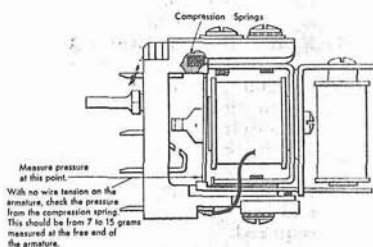

Figure 22. Adjustment 2

centrally located on the contact strap. Armature end shake must not permit the wires to move within $\frac{1}{64}$ " of the sides of the contact straps.

4. Figure 23. Adjust tension on the contact wires by shifting the wire holder so that a 45 to 55 gram pressure applied at the center of the free end of the armature just moves the wires away from the contacts on the normally closed side. The six position latch type relay will require 60 to 80 grams pressure.
5. Figure 24. Adjust the magnet yoke assembly so that with a .015" thickness gauge between the armature and yoke at the free end and the armature attracted, all contact wires make contact on the normally open side. With a .020" gauge between armature and yoke and the armature attracted, none of the wires are to make contact on the normally open side. This adjustment is obtained by shifting the yoke assembly at the lower end only so that the wire holder adjustment does not change. If it is necessary to loosen the entire yoke to correct an out-of-parallel condition, the wire holder will have to be repositioned for proper wire tension. Be sure residual remains in proper position.
6. Figure 25. The damper screw should be adjusted to allow .003" to .005" movement between the vinylite damper and the wire bracket before the wire bracket can move any contact wire. If the screw is loosened, the vinylite damper must be pressed back into the moulding before checking the clearance between the damper and the wire bracket. Once adjusted at the factory, the damper screw is sealed with cement #198896.
7. Figure 26. With the relay coil energized, there should be .003" to .005" latching clearance between the relay armature and the latch at the latching point. To change this adjustment, add or remove shims 186710 between the relay magnet yoke and the latch magnet yoke as required.
8. Figure 27. With the latch magnet energized, the latch armature should clear the relay

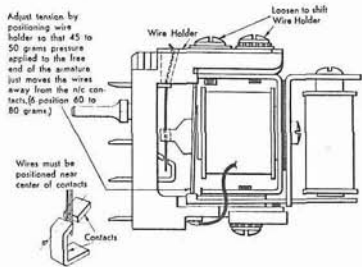

Figure 23. Adjustments 3 and 4

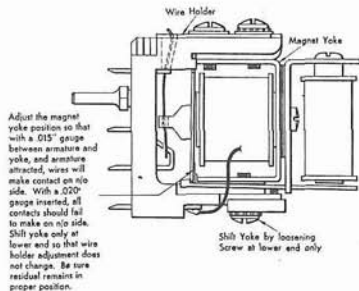

Figure 24. Adjustment 5

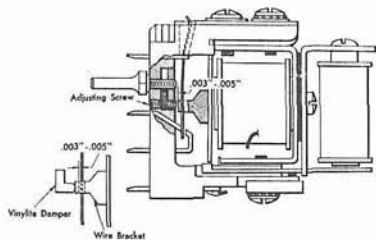

Figure 25. Adjustment 6

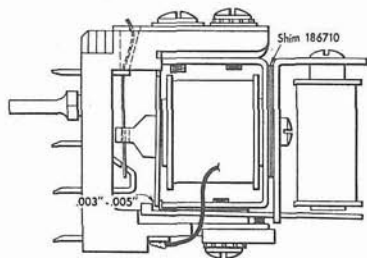

Figure 26. Adjustment 7

armature by .003" to .006" at the latch point. At the same time check for a minimum clearance of .010" between the bottom of the latch armature and the relay moulding as there should not be any interference with the movement of the latch armature at this point. If any change is necessary, form the latch armature at point A.

9. Figure 28. With the relay armature in the latched position, the point of contact of the latch should be at the 90° angle of the armature residual.
10. Figure 29. The latch should release the relay armature from its latched position when a pressure of 25 to 40 grams is applied to the extreme core end of the latch armature. The latch on the 6-position relay will require a pressure of 100 to 125 grams.

WIRE CONTACT RELAY TESTING DEVICE — PART 454199

THE WIRE CONTACT relay testing device is a small compact unit which provides the customer engineer with a means for testing the making and breaking conditions of all the contacts on a wire relay. The results of testing are indicated by two jewelled lights. One light labeled N/C, indicates by glowing when a N/C contact is made; the other light labeled N/O, when glowing, indicates that the N/O contact is made. The N/O light is equipped with a red jewel while a green jewel identifies the N/C light (Figure 30A).

By means of the light indications it is also possible to check visually the pickup and drop-out action of the relay when it is operated by each of the several coils. The contact points may be checked by manual operation of the relay or under power.

In addition to the above mentioned lights the device consists of a terminal receptacle which will accommodate the standard 4, 6 and 12 position, 1 or 2 coil relays. Three coil relays (4 position), including the latch type wire contact relay, may also be tested on the device.

When the 4, 6 or 12 position, one- or two-coil relays are to be tested, they must be plugged with #1 position

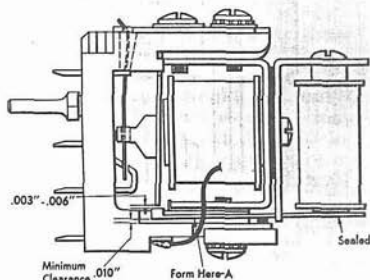

Figure 27. Adjustment 8

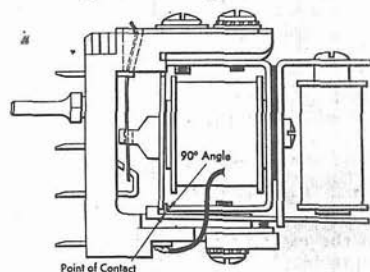

Figure 28. Adjustment 9

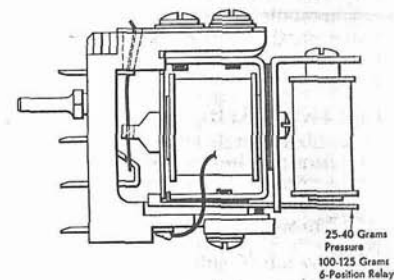

Figure 29. Adjustment 10

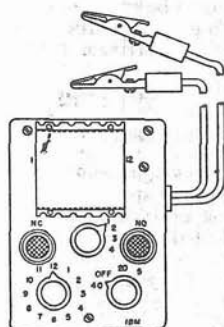

Figure 30A. Relay Tester

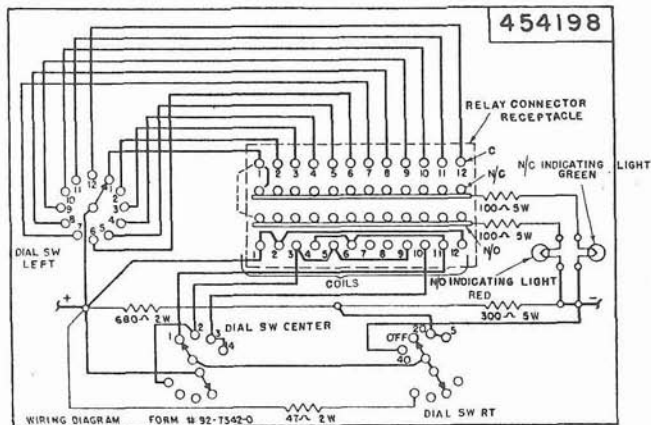

Figure 30B. Testing Device Wiring Diagram

to the extreme left of the receptacle. When three-coil, (4 position) relays are to be tested, they must be plugged to the extreme right side of the receptacle.

Wiring diagram 454198 (Figure 30B) shows the electrical connections of the relay testing device.

Three dial switches are also provided on the device and are used for selection and control purposes. They are:

Dial Switch (Left)

1. This switch controls the selection of the twelve (12) possible contacts to be tested and has indicated switch settings of 1 through 12.

Dial Switch (Center)

2. Dial switch (center) controls the selection of the relay coils (PU1, PU2, Hold or Latch Trip) to be energized during the testing procedures. There are four (4) settings, 1 through 4. These are listed below under two headings, namely, one and two-coil switch settings and three-coil switch settings.

(a) One and Two-Coil Relay Switch Settings

No. 1 position connects the PU coil of the standard 4, 6 and 12 relays to the power source.

No. 2 position connects the hold coil of the 4 and 6 position relays.

No. 3 position is not used on two-coil relays.

No. 4 position connects the hold coil of the 12 position relay.

(b) Three-Coil Relay Switch Settings

No. 1 position connects PU2 coil of a three-coil relay.

No. 2 position connects PU1 coil.

No. 3 position connects the hold coil or the latch trip coil, depending upon the type of three-coil relay being tested.

No. 4 position is not used on this type relay.

Dial Switch (Right)

3. This switch controls the selection of the voltage values to be used during testing.

Switch settings are indicated as 40, OFF, 20 and 5, representing these voltage values and the "power off" condition of the coil circuits.

This switch *must* always be OFF when inserting the relay into or removing it from the terminal receptacle of the testing device to prevent burning the contacts of the receptacle.

The device is to be connected to a 40-volt DC supply. Wire leads of ample length, with connecting clamps are supplied to facilitate connection to the power source. This source voltage should be checked with a meter and should be within the 40- to 46-volt range to insure the desired results.

Test Objectives — Procedures — Adjustments

1. CHECKING NORMALLY CLOSED CONTACT POINTS

- a. Set dial switch (right) to OFF position.
- b. Insert relay, correctly, into connector receptacle.
- c. Using dial switch (left) select each contact position and check all N/C contacts. Green jeweled lamp should glow for each position selected when N/C point is made.
- d. Operate the armature manually and slowly toward the yoke. N/C (green) light should go out for each position before any of the contact wires have shifted to the N/O contacts, where the red lamp will glow. Then as the armature is released slowly, the same condition should be true in reverse with regard to the transfer indication from N/O to N/C contacts; great care should be exercised to release the armature so that the contact wires reach their N/C position slowly enough to detect faulty contacts because of excessive friction or insufficient tension. Proper use of the hand operation test provides an excellent means of determining proper alignment and contact tension. If the armature is operated and released too quickly, the purpose of the test is defeated. Repeat this hand operated test a number of times for each contact position to insure a satisfactory operating condition. Adjust or replace those contact wires when the test indicates improper alignment and tension conditions.

- e. 1. Insert a .015" thickness gauge between end of armature and yoke.
2. Energize the relay by setting dial switch (right) to the 40-volt position.
3. Center dial switch is set to 1 to energize 1 coil (2 position for three-coil relays).
4. With armature attracted, neither the N/C (green) nor the N/O (red) light should glow. Test every position by means of dial

switch (left). Run the finger lightly over the adjustable ends of the wires and if any lights come on, they should go out as soon as the finger leaves the wire. If the N/C light is on for a number of contact positions with a .015" gauge in position and the relay energized, adjust as follows: Loosen the screws holding the relay molding to the yoke side of the relay where contact adjustment is made and change the relation between the yoke and molding until light goes out for all positions. If a single wire makes, it may be malformed and should be replaced.

5. *Important*—Do not alter the position of the residual with respect to the magnet yoke nor disturb the contact wire holder.

2. CHECKING NORMALLY OPEN CONTACT POINTS

- a. 1. Insert a .010" thickness gauge between end of armature and yoke.
2. Set dial switch (center) to position 1 and dial switch right to 40 volts.
3. With gauge inserted and relay energized by power, the N/O (red) light should glow. Check each position by setting dial switch (left) accordingly. If the N/O (red) light does not glow for all positions, adjust by method indicated in 1e. With .010" gauge inserted and relay energized, run finger over wire contacts adjustable ends to make sure that when finger is removed the light is on for all positions.
- b. A relay may be considered to be in operating adjustment until the tester light indicates failure to make on the N/O (red light) side, in any position, with a .005" gauge inserted between armature and yoke.

3. TESTING ARMATURE PICKUP AND HOLD ACTION (ONE AND TWO-COIL RELAYS)

A check on armature pickup and drop-out action may be made with the

aid of the testing device by visually observing speed of light indications and armature actions (see High Resistance Hold Coils—HRH).

Testing PU and Hold Coil (except HRH)
— 40-Volt Test

- a. 1. Set dial switch (center) to position 1, 2 and 4 in turn.
2. Turn dial switch (right), to the 40-volt position. The armature should respond very speedily thus causing the N/O (red) light to glow immediately. Reset dial switch (right) to OFF. Armature should drop out immediately and rapidly. Remember that pickup time is 4-6 MS and drop-out time approximately 4 MS so armature action must necessarily be fast and positive.

Testing PU and Hold Coil (except HRH)
— 20-Volt Test

- b. 1. Set dial switch (center) to positions 1, 2 and 4 in turn.
2. Set dial switch (right) to the 20-volt position.
3. The armature should be fully attracted, although somewhat slower than with the 40-volt power source. It should be positively held by the 20-volt source.
4. While the armature is being held by the 20-volt source, turn the dial switch (right) to the 5-volt position. The armature should return to the de-energized position immediately with only 5 volts applied to the coil.

Note: the transfer from the 20-volt to the 5-volt switch position is accomplished by means of a sliding contact between these positions, thus preventing an open circuit during the switching operation.

4. TESTING PU, HOLD AND LATCH
TRIP COILS (THREE-COIL RELAYS)

Three-coil relays must always be plugged to the extreme right of the relay tester receptacle.

At present there are two standard types of three-coil wire contact relays: the one type consisting of two pickup (PU1 and PU2) and a hold coil, the other known as the latch type and

consisting of two pickup coils (PU1 and PU2) and a latch trip coil.

(a) Non-Latch Type — 3-Coil Relay

To test PU1, PU2 and hold coils (except HRH) 40 volt test:

1. Set dial switch (right) to the 40 volt position.
2. To test the several coils set dial switch (center) as follows:
 - (a) No. 1 position connects PU2 coil.
 - (b) No. 2 position connects PU1 coil.
 - (c) No. 3 position connects the Hold coil.

The armature should be picked rapidly with power applied. Turn dial switch (right) to OFF position and the armature should return immediately and rapidly to the de-energized position.

(b) Latch Type — 3-Coil Relay

To test PU1, PU2 and latch trip — 40 volt test:

1. Set dial switch (right) to 40 volt position.
2. To test the several coils set dial switch (center) as follows:
 - (a) No. 1 position to connect PU2 coil.
 - (b) No. 2 position to connect PU1 coil.
 - (c) No. 3 position to connect Latch Trip coil.

When power is applied to either PU1 or PU2 coils, the armature should be picked rapidly and latched in the energized position.

When the latch trip coil is energized, the armature should be unlatched and be restored to normal immediately.

(c) To test PU Hold and latch trip coils (three-coil relay) — 20-volt test:

Three-coil relays, when tested under the 20 volt power source, should attract the armature and hold it to the core positively. As in the case of the two coil relays, the armature action will however be a great deal slower. Energizing the latch trip coil from the 20 volt source should unlatch the armature successfully. With the 5 volt power applied these relays should not pick, hold or unlatch.

High Resistance Hold (HRH)
Coil Relays

The #2 or hold coils of all standard relays are either of the same resistance as the pickup coil or of a higher value. These high resistance hold coils (HRH) are applied wherever a relay

may remain energized an indefinite length of time. They are used to prevent coil destruction.

(HRH) coils are not subject to the same voltage tests as applied to the standard coils in the foregoing test procedures.

A continuity check should be made on these coils by applying 40 volts. The armature should be attracted quite rapidly and positively held to the core. It has been found that by applying 20 volts to these coils the armature action is sluggish and in some cases it will not be fully attracted.

On machines leaving the factory after approximately May 1, 1949, these HRH coils may be identified by an orange or reddish coil covering.

CARD COUNTING DIAL RELAY

The card counting dial relay is a single position counting mechanism with a capacity of 1 to 9. At present it is applied in the circuits of the Collator Type 077 Counting Device and several special device circuits of the Type 405 machine.

Several of these dial relays may be coupled together (control panel plugging) in order to increase the counting capacity. For example, two coupled relays will provide a capacity of 1 to 99; three coupled relays, a capacity of 1 to 999; while coupling four relays will permit counting variables from 1 to 9999. These counter relays can add only unit impulses, and they can add only once during a machine cycle.

Each time the count magnet (Figure 31) is impulsed, the armature is attracted. The armature carries a pawl which engages a ratchet and advances the contact finger one position clockwise around a dial. This dial consists of ten contact segments corresponding to the characters 0 to 9. Thus, after a variable number of cards or unit impulses have been counted, the contact finger, having advanced one step for each impulse, will be positioned on the segment corresponding to the number of impulses counted.

The position of the contact finger, in relation to the dial contact segments 0 through 9, permits an electrical reading of the figure stored in the relay.

When the restoring magnet is impulsed, the tip of the armature which

serves as a detent releases the ratchet and allows the contact finger to return to its zero position.

Adjustments

1. The end play in the armature pivots should not exceed .005". Bend armature pivot ears to adjust.
2. There should be .004" clearance between the count magnet armature and the yoke when the armature is attracted. Adjust by loosening lock nut and moving armature pivot. Be sure armature is parallel with the yoke.
3. Bend stop arm under yoke for .020" to .024" armature core air gap on count magnet when de-energized.
4. The drive pawl should seat in the #9 tooth with .005" take up between the pawl and ratchet tooth when the contact wiper is resting against the stop pin. If this clearance is not obtained, bend contact wiper stop ear.
5. There should be a .004" clearance between the restoring magnet armature and the yoke when the armature is attracted. A .003" thickness gauge should go and a .005" should not go. Check as in paragraph 2.
6. There should be .008" to .010" clearance, preferably .008", between the restoring magnet armature and core when the magnet is de-energized. Adjust by bending armature at point indicated. With .008" air gap, the detent tip of the restoring magnet armature should clear the ratchet by at least .010" when the magnet is energized. This can be observed through a hole in the frame.
7. Bend the tip of the restoring magnet armature which serves as a detent for .005" clearance between the detent surface and the ratchet tooth when contact wiper arm is against the stop pin. Recheck adjustment 6.
8. There should be .005" overthrow of the ratchet beyond the detent. Bend end of count magnet armature to obtain this adjustment. Recheck adjustment 4 if this is changed.
9. Adjust the pawl stop by sliding in the elongated hole, for .005" to .008" clearance between the

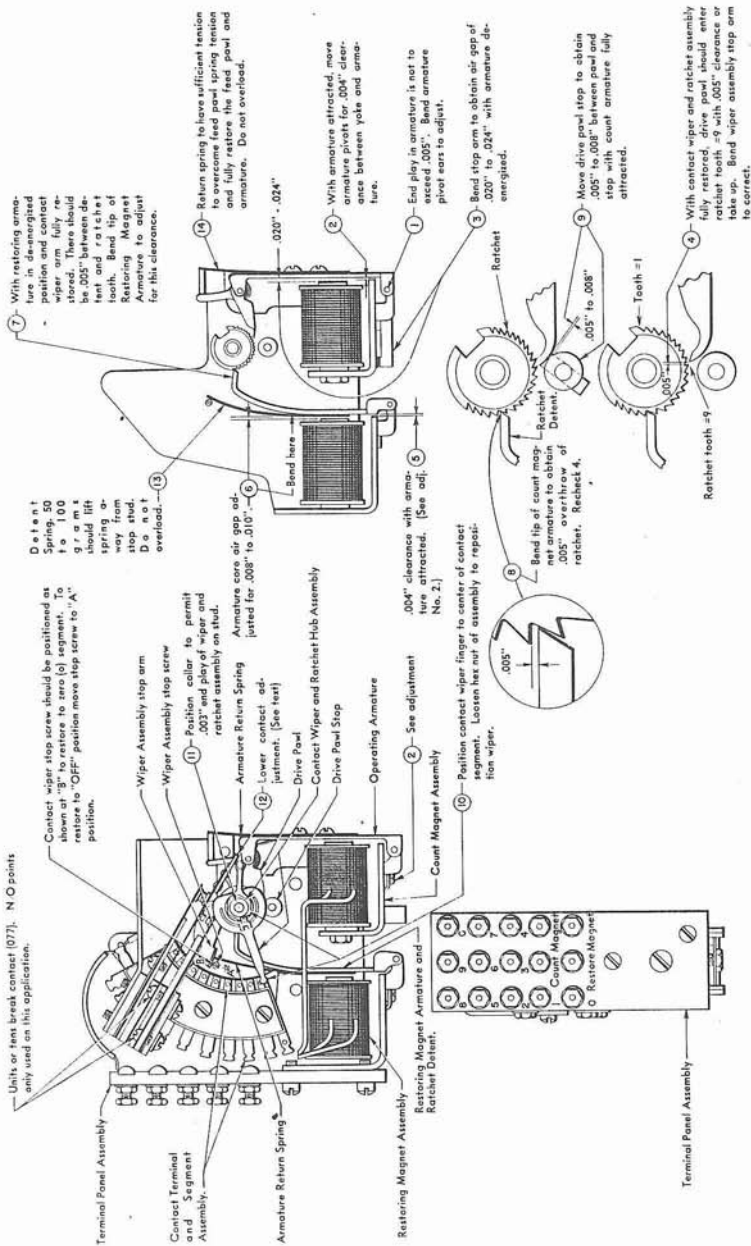

Figure 31. Card Counting Dial Relay

- pawl and stop when the count magnet armature is attracted.
10. The contact wiper should seat on the center of the contact segment when detented. To position the contact finger, loosen hex locking nut and move the contact finger with a screwdriver. When tightening the hex nut, hold the stop arm against the stop pin and the break contact operating arm toward base of relay. The contact segment assembly may be moved through elongated holes for minor changes in this adjustment.
 11. Position shaft collar to allow .003" end play.
 12. The break contact should be made on the lower side with a clearance between the center strap and the contact operating arm when the step relay is in the 1 position.
 13. The tension on the flat restoring magnet armature spring should be sufficient to detent the ratchet properly without causing the armature to be sluggish on the pickup. With the coil de-energized, a scale reading of 50-100 grams should just lift spring away from stop pin.
 14. The tension on the flat count magnet armature spring should be just sufficient to overcome the tension of the feed pawl spring and to return the pawl away from the ratchet. Too much tension will cause counting. under. Keep a clearance between tension spring and end of armature. Adjust spring for 100-150 gram with coil de-energized.
 15. Tension on the contact finger should be sufficient to cause either strap to follow approximately $\frac{1}{8}$ " when the other strap is raised. This adjustment must be made with the contact finger beyond the segments.
 16. Both count and restoring magnets should operate in from 24 to 30 milliseconds.