

IBM

Customer Engineering
Manual of Instruction

7090

Power Supply

Control and Distribution

IBM Customer Engineering Manual of Instruction

**7090 Power Supply
Control and Distribution**



Mr. John V. Gardner
2950 Stonecreek Rd. SE
Smyrna, GA 30080-3320

FOREWORD

This manual has been prepared for teaching purposes and as an aid for learning the IBM 7090 Converter Power Supplies. All material is related to production at a given engineering change level; use of this manual as a reference is subject to changes in the system.

Text and illustrations explain the theory and logic of the modular power supplies, the power control unit, the power converter unit, and tape unit power supplies.

MAJOR REVISION (February 1961)

This edition, Form 223-6904, obsoletes Form 223-6839. Significant changes have been made throughout the manual, and this new edition should be reviewed in its entirety.

POWER SUPPLY CONTROL AND DISTRIBUTION

CONTENTS

1.0.00	INTRODUCTION	5
2.0.00	MODULAR POWER SUPPLIES	7
2.1.00	Standard Modular Power Supply Unit	7
2.1.01	Rectifier Voltage Supplies	9
2.1.02	Three-Phase Variac	10
2.1.03	Marginal Voltage Development	11
2.1.04	Magnetic Amplifiers	11
2.1.05	Saturable Reactor	12
2.1.06	Self-Saturating Magnetic Amplifier	15
2.1.07	Open-Fuse Detection	16
2.1.08	Thermal and Air-Flow Detect Circuits	17
2.2.00	7090 Special Voltage Power Supply Unit	17
2.2.01	Zener Diodes as Reference Voltage Devices	20
2.2.02	Neon Detection Circuits	21
2.3.00	The 2kw Core Storage Modular Supply	23
2.4.00	Thyratron Transistors	23
3.0.00	IBM 7618 POWER CONTROL UNIT	26
3.1.00	Motor-Generator Start-Stop Circuits	26
3.1.01	Power-On Key	26
3.1.02	Normal-Off Key	28
3.1.03	Emergency-Off Key	28
3.1.04	DC-Off Key	29
3.2.00	Power-On Sequencing	29
3.2.01	Core Storage Power-On Sequencing	31
3.2.02	Core Storage Power-Off Sequencing	33
3.3.00	Blower Motors and Convenience Outlets	33
3.4.00	Marginal Checking	34
3.4.01	Marginal Checking, +6v, -12v	34
3.4.02	Marginal Checking, +30v, +60v	38
3.5.00	Power Control Unit Special Voltage Supply	38
3.6.00	Power and Fuse Indicators	39
3.7.00	Power Cable Distribution	40
4.0.00	CONSOLE CONTROLS AND INDICATORS	42
4.1.00	Console Controls	42
4.2.00	Console Indicators	42
4.3.00	Module Panel Indicators	43
5.0.00	POWER CONVERTER	44
5.1.00	Motor-Generator Voltage Control	44
5.1.01	Field Flashing	44
5.1.02	Output Regulation	46
6.0.00	VOLTAGE SUPPLY, IBM 729 MAGNETIC TAPE UNIT	49
6.1.00	Magnetic Tape Unit DC Supply	49
6.1.01	Ferro Regulator	49
6.1.02	-48 Volt Supply	51
6.1.03	Plus 6 Volt Supply	51
6.1.04	Other Supply Circuits	51

1.0.00 INTRODUCTION

THE POWER SUPPLY used with transistorized circuits in standard modular systems (SMS) has four major parts:

1. The IBM 7608, a power converter or motor-generator set which converts incoming 60-cycle, three-phase (3ϕ), 208 v power to regulated 400-cycle, 3ϕ , 208v power.
2. Power supplies in each modular frame which supply voltage to all circuits in that frame.
3. The IBM 7618, a power control unit (PCU) which contains system power control circuits, motor-generator (M-G) regulator and marginal check Variacs*.
4. Marginal check (M/C) controls located in the main console.

The output voltage of the motor-generator set, a commercially available unit, is regulated, eliminating the need for voltage regulation in most of the modular power supplies. Using 400-cycle AC to rectifiers means fewer filter capacitors are required in the modular power supplies, as well as smaller transformers.

Figure 1.0-1 shows the logic of the power system. Two power supplies are located in each modular frame; one supply (power supply A) is for gates A and B; the other (power supply C) is for gates C and D. The power supplies are three-phase, full-wave rectifiers using the 400-cycle output of the generator. All rectifiers are silicon diodes which have large current carrying capacities. The power supplies are physically located at the rear of each slide in the modular frame.

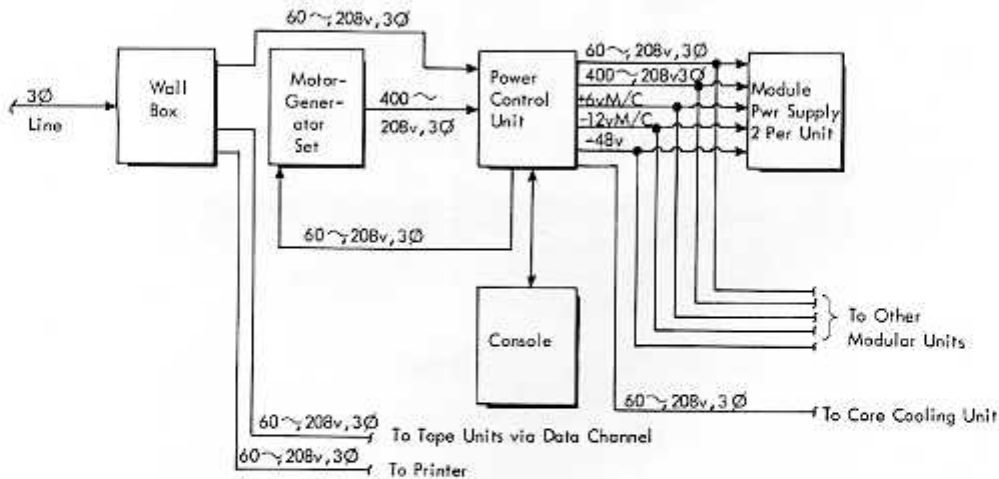

FIGURE 1.0-1. 7090 POWER SUPPLY SYSTEM

* Trademark of General Radio Company

Marginal checking may be performed on part of the +6v supply, part of the -12v supply, and core storage driver collector voltages. Marginal check controls for all units are mounted on the console unit.

Each modular power supply has its own open-fuse detection circuit. In 7090 systems, a blown fuse drops power to only its own frame. Interlock circuits drop power to the second half of the unit when a fuse blows.

The PCU is a separate frame containing circuits which control power to all modular units. Power sequence contactors, power-on and marginal check Variacs, blower relays and their overload circuit breakers (CB), and system power control keys are the major circuits in the PCU.

Power is brought up in the system by closing a power-on key, which starts the motor-generator. A power-on Variac, through contactors for the modular frames, brings all voltages, except core storage power transistor collector voltage, up slowly. A second Variac cycle brings up collector voltage to the core storage power transistors through a special power supply in the core storage module.

Power for the tape drives is from the wall outlets through the channel module, where the power is interlocked with a data channel power-on relay.

A 55 volt supply and a 48 volt supply located in the printer furnish necessary DC voltages to the card machines.

2.0.00 MODULAR POWER SUPPLIES

2.1.00 STANDARD MODULAR POWER SUPPLY UNIT

Each SMS unit contains two independent standard power supply units. Supply voltage for the units is 400 cycle, 3-phase, 208v power from the power converter unit. Each standard power supply unit controls two of the SMS unit's four gates: one power supply unit supplies gates A and B; the second unit supplies gates C and D.

7090 Standard Modular Power Supply

A typical standard modular supply is shown in Figure 2.1-1.

Figure 2.1-2 shows the logic of a standard power supply unit. A single transformer feeds all rectifiers in the unit. Each unit (Figure 2.1-3) develops nine separate voltages. Marginal check voltages M/C-1 and M/C-2 are voltages that may be varied to marginal-check the unit. M/C-1 voltages vary the voltage in gate A; M/C-2 voltages vary the voltage in gate B. (The power supply that feeds gates C and D uses M/C-1 for gate C and M/C-2 for gate D.)

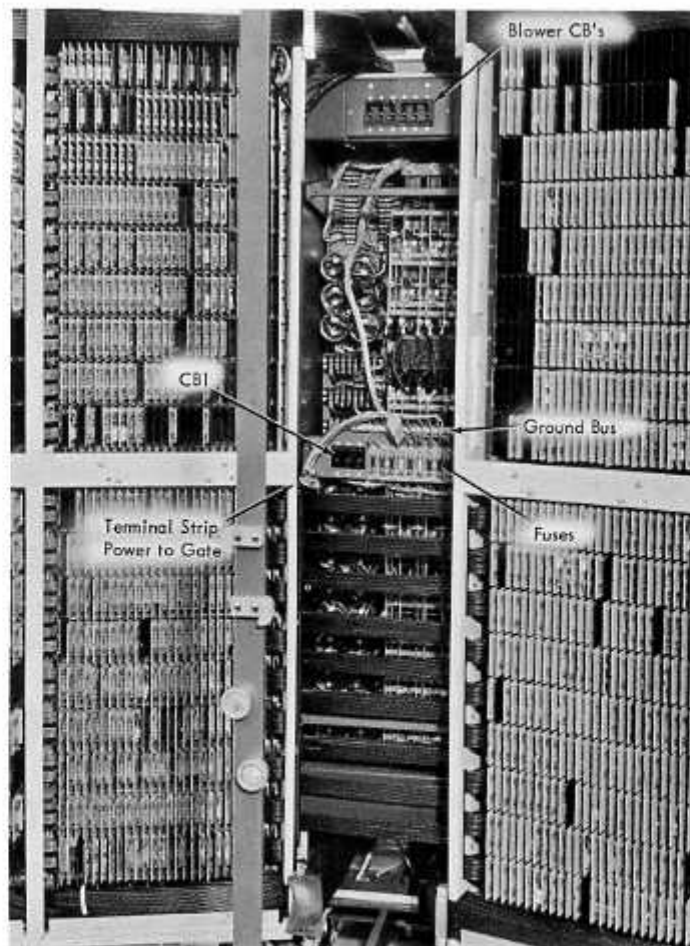

FIGURE 2.1-1. 7090 STANDARD MODULAR SUPPLY - INSTALLED IN 7607

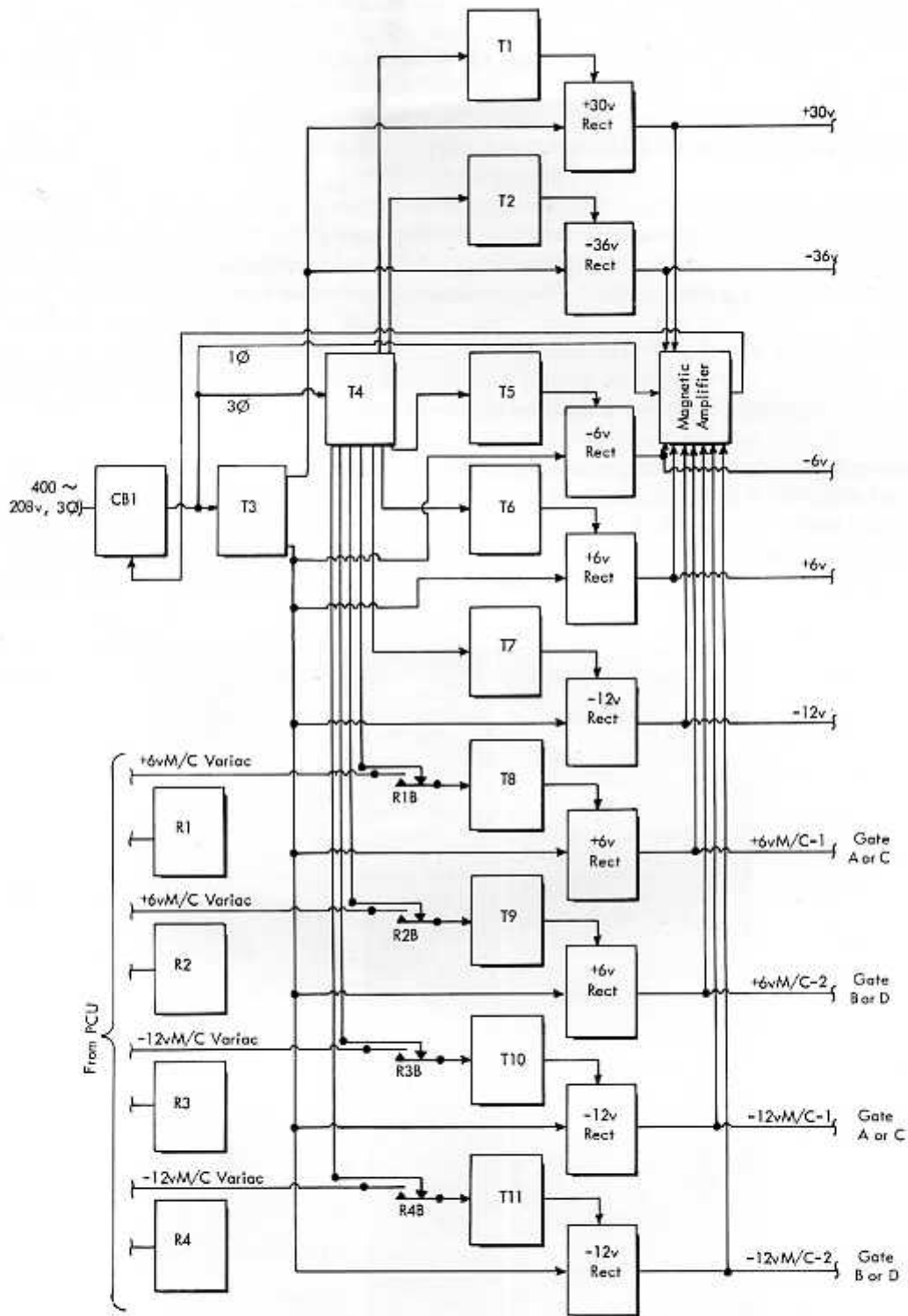

FIGURE 2.1-2. STANDARD POWER SUPPLY UNIT

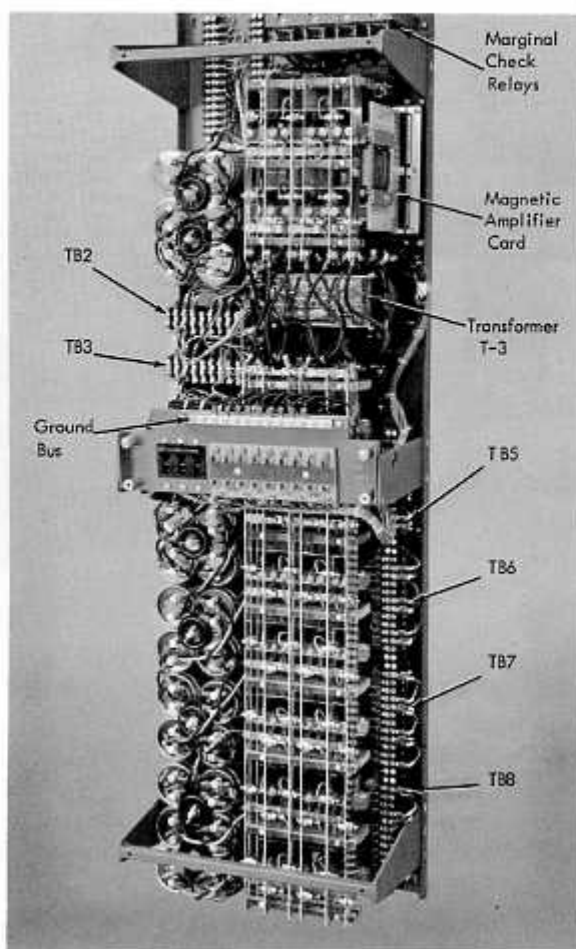

FIGURE 2.1-3. STANDARD MODULAR SUPPLY

Schematically, each of the nine separate voltage supplies are identical. Each supply feeds a magnetic amplifier, which opens the CB points (feeding the input of T3) if a fuse opens. Another point on the CB drops all DC power to the SMS unit in which the fuse opened.

2.1.01 Rectifier Voltage Supplies

A typical voltage supply is shown in simplified form in Figure 2.1-4A. When the positive-going pulse A is seen at the plate of rectifier C, electrons flow from point E through the load, half of the secondary winding of T5, rectifier C, the secondary of T3, and back to point E. When the plate of diode D goes positive, current again flows from point E through R_L , half of the secondary winding of T5, rectifier D, the secondary of T3, and back to point E. The result is a full-wave rectifier.

In the Figure 2.1-4A, any action of T5 is ignored. With T5 in the circuit, the output voltage V_L can be varied under control of the primary winding of T5.

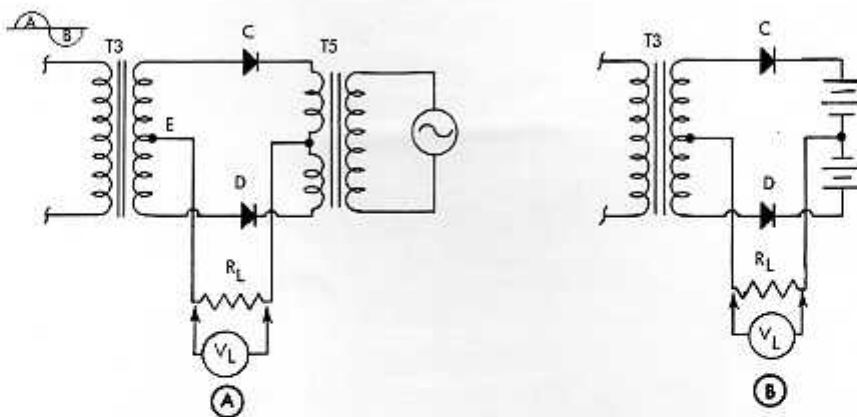

FIGURE 2.1-4. SIMPLIFIED VOLTAGE SUPPLY

If a voltage source is applied to the primary winding of T5, a voltage is developed across the secondary windings of T5. The polarity of this voltage either aids or opposes the output voltage of the rectifier. When a positive-going pulse appears at rectifier C (Figure 2.1-4B) conduction cannot begin until the voltage level of the pulse at the plate overcomes the bias of the battery in the cathode circuit. As a result, current flows for a shorter period of time during each cycle and, V_L decreases. The reverse is true if the voltage source is added with opposite polarity; the rectifier conducts at a lower plate voltage and V_L increases.

Several advantages are obtained from this type of circuit:

1. In actual 6v and 12v power supply circuits, the voltage on the primary of T3 is such that V_L should be 9v. By bucking or boosting 3v, it is then possible to obtain both 6 and 12v supplies with identical circuitry and parts.
2. By replacing the voltage source in the primary winding of T5 with a tapped output transformer, changing the tap settings adjusts voltage V_L for exact values to compensate for variations in component values and line loss.
3. Replacing the voltage source in the primary winding of T5 with a Variac allows the voltages to be varied either up or down for marginal checking.

2.1.02 Three-Phase Variac

A three-phase Variac (Figure 2.1-5A) is analogous to a three-phase potentiometer. The movable point taps off a voltage somewhere between the incoming line voltage and AC neutral. The line-to-line output voltage is shown in Figure 2.1-5B. With the movable point of the Variac at the bottom of the coil, or point A in Figure 2.1-5A or B, all output lines are effectively tied to the AC neutral line and no voltage exists between lines. As the movable point is moved up along the resistance coil to point B, a gradual increasing voltage develops between output lines. The voltage between points B-B is the voltage between output lines; the voltage A-B is the output line-to-AC neutral voltage. As the movable point is moved up the coil to point C, the output-to-line voltage increases until it is the same value as the input voltage.

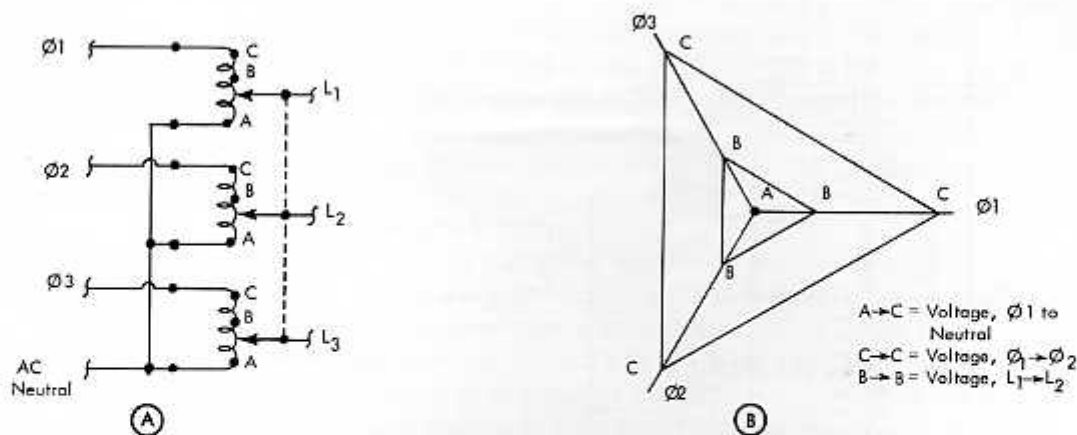

FIGURE 2.1-5. THREE-PHASE VARIAC

Variacs are used to bring circuit voltages up slowly and to vary individual supply voltages for marginal testing.

2.1.03 Marginal Voltage Development

Marginal voltages are developed by varying the amount of buck or boost voltage in the rectifier circuit. A typical marginal voltage supply is shown in Figure 2.1-6. Notice that the primary winding of T5 can be energized from two sources under control of relay R1. Under normal operation, R1 is de-energized as shown and T5 primary voltages are supplied from the tapped outputs of T4 as shown in Figure 2.1-2. When R1 is energized, the primary of T5 is then under control of the Variac; the amount of buck or boost voltage in the rectifier circuit can now be varied to change the output voltage to marginal limits. The Variac is approximately in the center of its operating range with circuit voltages at normal values; this allows a full range of upper and lower voltage limits. Relays R1, R2, R3 and R4 are constructed so that the n/o points close before the n/c points open.

2.1.04 Magnetic Amplifiers

Magnetic amplifiers are variable impedance devices. The impedance offered by the amplifier is varied by an independent source of control power; amplification occurs because the power requirements of the control source may be many times less than the power being controlled. By varying the controllable impedance, output circuit current and voltage are controlled.

Magnetic amplifiers vary widely in size and shape, depending on their use, but all use a saturable core with one or more control windings. Magnetic amplifiers may be classified in two types: saturable reactor or self-saturating.

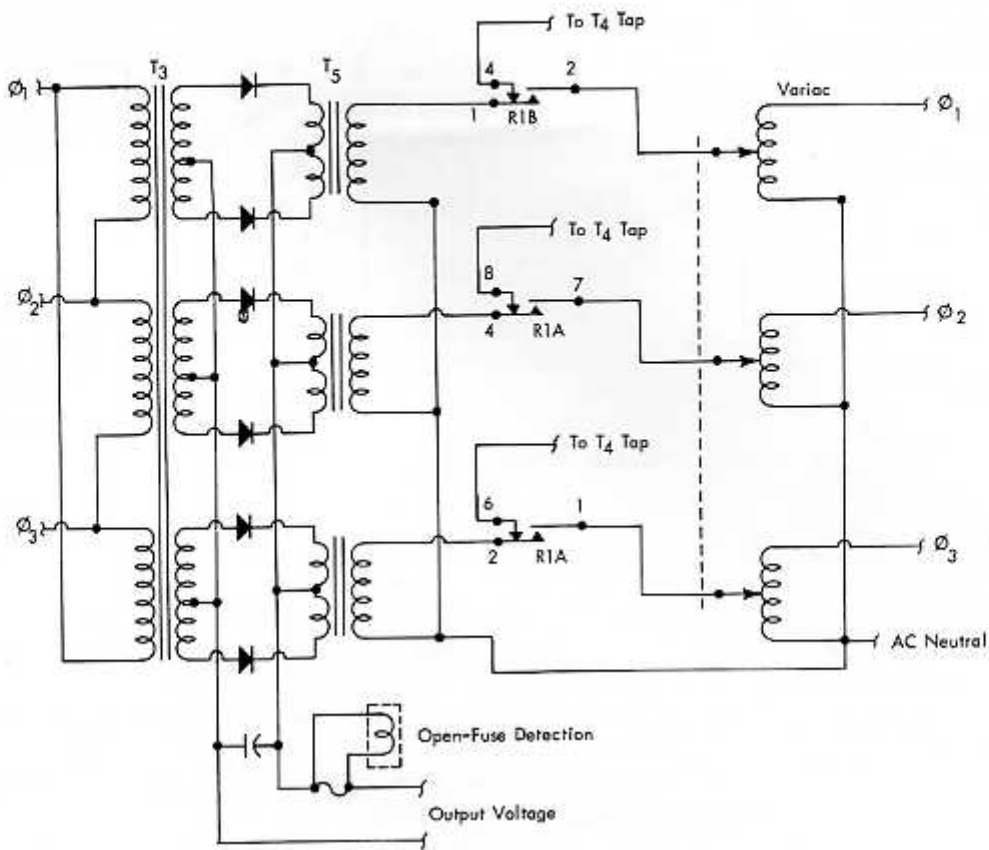

FIGURE 2.1-6. MARGINAL VOLTAGE DEVELOPMENT

2.1.05 Saturable Reactor

A saturable reactor (SR) is an inductor in which the impedance is controlled by varying the amount of flux in the core. Figure 2.1-7A uses an adjustable impedance (X_1) to represent a saturable reactor. By moving the adjustable tap A, the amount of impedance may be varied, controlling the voltage across R_L . Assume that R_L can be varied and that it is desired to have V_L remain constant. Reducing R_L tends to reduce V_L but, if X_1 is adjusted at the same time so that it has less impedance, more current flows through the circuit and V_L can be held constant.

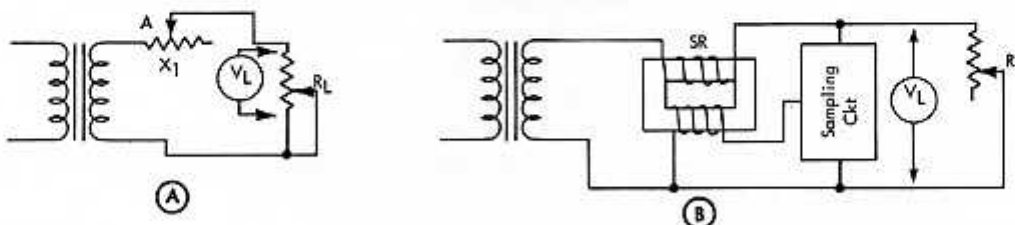

FIGURE 2.1-7. SATURABLE REACTOR ANALOGY

In Figure 2.1-7B, a saturable reactor replaces impedance X_L . The impedance of a saturable reactor is controlled by varying the magnetic flux in the core of the inductance coil. Because the impedance of an inductance coil is a function of the change in magnetic flux, the greater the change in flux, the greater the impedance. If the core of the SR is saturated (can hold no more flux) there can be no change in flux and the impedance is only the DC resistance of the coil. The farther away from saturation, the greater the impedance.

Assume that R_L (Figure 2.1-7B) is variable, but that it is desired to keep the voltage across R_L constant. A sampling circuit is used to measure the voltage across R_L . The output of the sampling circuit feeds a second (control) winding on the SR. This control winding determines how far the core is from its saturation point. Flux from the control winding can oppose or aid that of the inductance coil. Whether the flux from the control winding aids or opposes the flux from the inductance winding is determined by circuit design.

If R_L (Figure 2.1-7B) is increased, the sampling circuit detects the increase in voltage across R_L and causes the impedance of the SR to increase. The change in impedance of the SR allows less current to flow in the circuit and the voltage across R_L returns to its controlled value.

The operation of the SR can be explained in greater detail by use of a hysteresis loop. (Figure 2.1-8A shows two windings on a laminated saturable core; for the first portion of the discussion, disregard any action of the control winding.)

An alternating current A (Figure 2.1-8C) is applied to the circuit. As the current progresses from point a, b, c, d, to a', the core material (Figure 2.1-8B) has completed one progression around its hysteresis loop (points a, b, c, d, and back to a). The hysteresis loop shown is an ideal loop. An ideal loop is used because many factors (predominantly heat and frequency) can alter its shape.

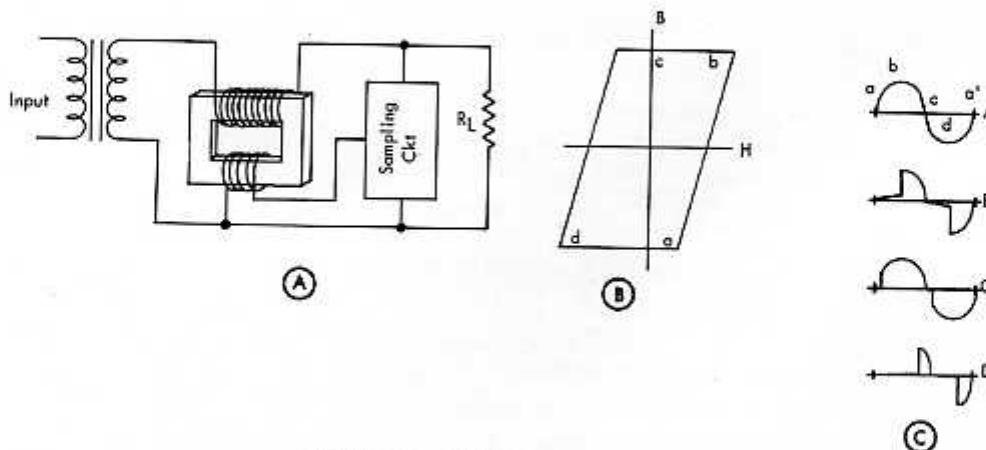

FIGURE 2.1-8. SATURABLE REACTOR CHARACTERISTICS

The output current wave form is shown at B in Figure 2.1-8C. During the first half cycle, the core follows the path ab on the hysteresis loop (Figure 2.1-8B). The changing flux in the core causes a high impedance in the inductance coil and little current flows. When the saturation point of the hysteresis loop is reached, there can be no additional change in flux. With no changing flux, the impedance of the inductance coil drops sharply; conversely, the output current rises sharply and follows the input current. As the input current goes from point b to c (Figure 2.1-8C), the operating point on the hysteresis curve goes from point b to c (Figure 2.1-8B). The movement from point b to c on the hysteresis curve involves such a small change in flux that the induced voltage is negligible and output current follows input.

The control winding controls the point along the input wave form at which the core goes into saturation. By driving current through the control winding, the amount of impedance in series with R_L is effectively changed. Waveform C (Figure 2.1-8C) shows the output current that would result from adding to the core current which allowed the core to saturate with only a small amount of input current. Current in the opposite direction through the control winding could cause output D (Figure 2.1-8C).

Driving current through the control winding in two directions as is required to obtain the output currents C and D (Figure 2.1-8C), can require complicated circuitry. To simplify circuitry it is desirable to be able to control output voltage by driving current through the control winding in only one direction. A third winding, called a bias winding, allows the desired simplification.

Figure 2.1-9 is a circuit using a bias winding. Current through the bias winding normally is in a direction such that the flux produced by it opposes the flux of the SR inductance coil. The theory of operation of the circuit with a bias winding is the same as for the other circuits previously described. The bias winding sets the static condition of the circuit which, in terms of V_L (Figure 2.1-9A), would produce a very low voltage. The control winding then carries current of sufficient value to control V_L . Figure 2.1-9B is a graphic view of the circuit operation. If the SR core is saturated, current is at its greatest value (point C). With no control winding current, the output current (I_{RL}) is at its lowest value (point A). The normal operating point would be point B, which allows the greatest amount of control.

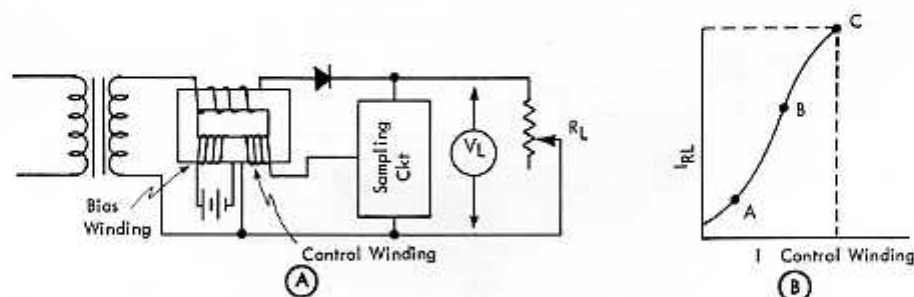

FIGURE 2.1-9. SATURABLE REACTOR WITH BIAS AND CONTROL WINDINGS

2.1.06 Self-Saturating Magnetic Amplifier

A self-saturating magnetic amplifier is a device using saturable reactors in series with a rectifier circuit. The circuit allows control of the current to an external load. A large amplification results, since a small amount of control current can cause a large change in load current. In IBM circuits, the self-saturating magnetic amplifier is normally referred to as simply a magnetic amplifier.

Figure 2.1-10 shows two saturable reactors in series with a full-wave rectifier circuit. Because of the action of the diodes in the rectifier circuit, current flows in only one coil at a time. The two reactor coils are wound to have flux in each core in the same direction.

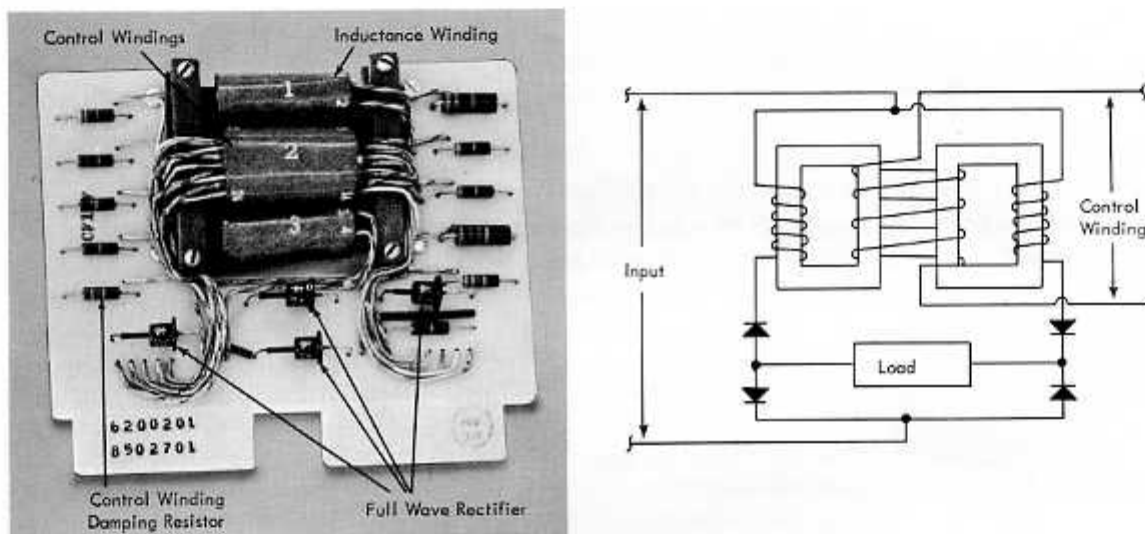

FIGURE 2.1-10. SELF-SATURATING MAGNETIC AMPLIFIER

Because the flux through each coil is in the same direction, the control winding works with each inductance coil on alternate half cycles. Figure 2.1-10 shows one control winding to the magnetic amplifier; actual circuits may use several separate control windings. Characteristic curves of magnetic amplifiers are drawn as a relationship between control winding ampere-turns and DC output current. Each line in a family of curves represents a different value of load resistance (Figure 2.1-11).

An analysis of Figure 2.1-11 shows that the curve follows the theory given for saturable reactors. As the ampere-turns of the control winding are increased, the SR reaches its saturation point earlier in the AC cycle and output current increases. A bias winding is normally used in magnetic amplifiers to allow a full output operating range. In most circuits, bias current tries to turn the amplifier off (the area where the output current is a minimum). Control winding current is then able to operate the amplifier throughout its complete output range.

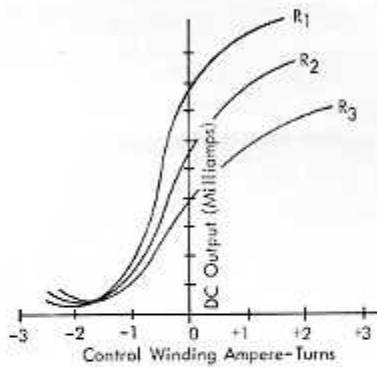

FIGURE 2.1-11. MAGNETIC AMPLIFIER CHARACTERISTICS

Figure 2.1-11 shows one factor that must be remembered when working with magnetic amplifiers; the output current never reaches 0; some voltage can always be measured across the load.

2.1.07 Open-Fuse Detection

The open-fuse detection unit is a magnetic amplifier (Figure 2.1-12A). Only one control winding is shown; in actual circuitry there may be as many as ten. Each control winding comes from a DC power supply and is shorted by a fuse; therefore, the winding has no effect on the amplifier so long as the fuse is good. The load is actually a CB trip coil, which drops DC power to the unit. Side switch interlocks on the CB itself drop power to the other half of the module when a CB trips.

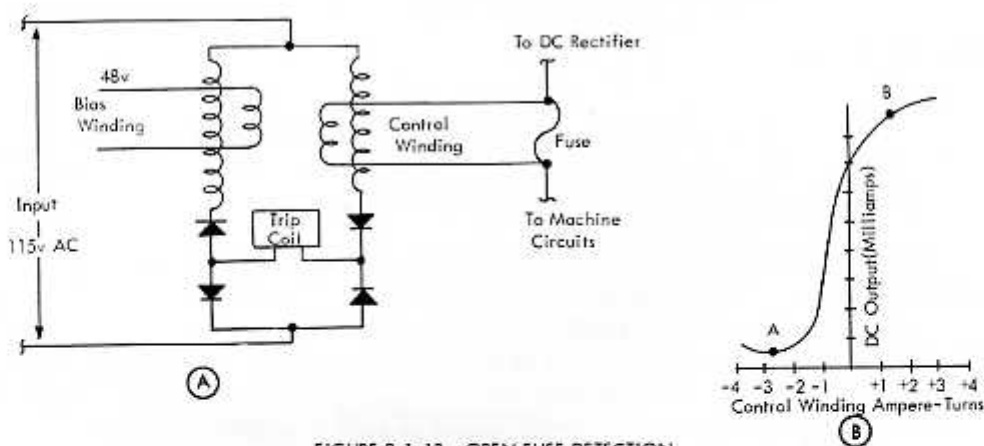

FIGURE 2.1-12. OPEN-FUSE DETECTION

A bias winding is used to establish an initial operating point. Figure 2.1-12B shows the characteristic curve for the circuit. The bias winding establishes the normal operating point (point A). If a fuse opens, the control winding is energized because the output of the rectifier must now flow through the control winding. With current in the control winding, operation is at point B of the characteristic curve. With operation at point A, current is at a minimum with a voltage drop of about 15v to 20v across the load. Operation at point B causes output current to increase and voltage across the load rises to about 60v to 70v.

The 15v to 20v which appear across the coil under normal conditions are of no consequence; it must be remembered that this is a normal condition.

2.1.08 Thermal and Air-Flow Detect Circuits

Magnetic amplifier circuits are also utilized for sensing an over-temperature condition or the failure of a blower motor in a standard modular gate. Because the opening of the -48 volt bias winding will cause the magnetic amplifier to operate the CB1 trip coil, the thermal sensing switches (two in the top of each SMS gate) have normally closed contacts in series with the bias winding supply.

Also in series with the thermal switches are the air-flow detect switches. These switches are similar to the heat-sensing thermal switches, with the addition of a half-heating device. The self-heating is composed of two resistors in parallel across the 12 volt supply, mounted in close proximity to the heat-sensing device. This unit is then located directly above the gate blower assembly. As long as the blower is running properly, the flow of air is sufficient to dissipate the heat generated by the resistors. If the blower should stop, the resistors would heat the sensing device and open the contact, thus tripping CB1.

Systems 9.02.15.1 shows a typical thermal wiring circuit in this case, CPU1. Note that with this particular circuit, either the AB supply or the CD supply may react to an open thermal sensing device in any of the four gates. The use of jumper wires makes it possible to locate any defective switch. Two types of switches are mounted on SMS cards for easy replacement.

2.2.00 7090 SPECIAL VOLTAGE POWER SUPPLY UNIT

Special voltages are needed for core storage. Figure 2.2-1 shows the power supplies mounted in the core storage frame. Load requirements in the driver circuits vary widely, especially in Z inhibit drivers. To accommodate the variation in load, core driver voltage supplies are regulated. Schematically, each supply is similar. The power supply assembly that provides core driver voltages is shown in Figure 2.2-2.

Figure 2.2-3 shows the special voltage power supply unit. The +60v, +30v, and -6v voltage supplies are fed from transformer T3. Each supply has a saturable reactor in series with a rectifier. Rectifier output is sampled by a voltage control circuit which feeds the SR for output regulation. Note that the sampling voltage for the -6v supply is taken from a point beyond the fuse. Because the -6v supply delivers relatively high current, the fuse holder contacts have a small voltage drop across them; for greatest accuracy, output is sampled on the load side of the fuse.

The -6v supply voltage control circuit differs in one other respect; a line from the +30v supply is used. The +30v line is used to establish a divider, between +30v and -6v, from which a reference voltage may be obtained. The circuit is designed this way for cost reduction because devices which can establish a reference voltage between a -6v line and ground are expensive. Also, with this circuit design the same type of reference voltage device can be used in each supply for greater standardization of parts.

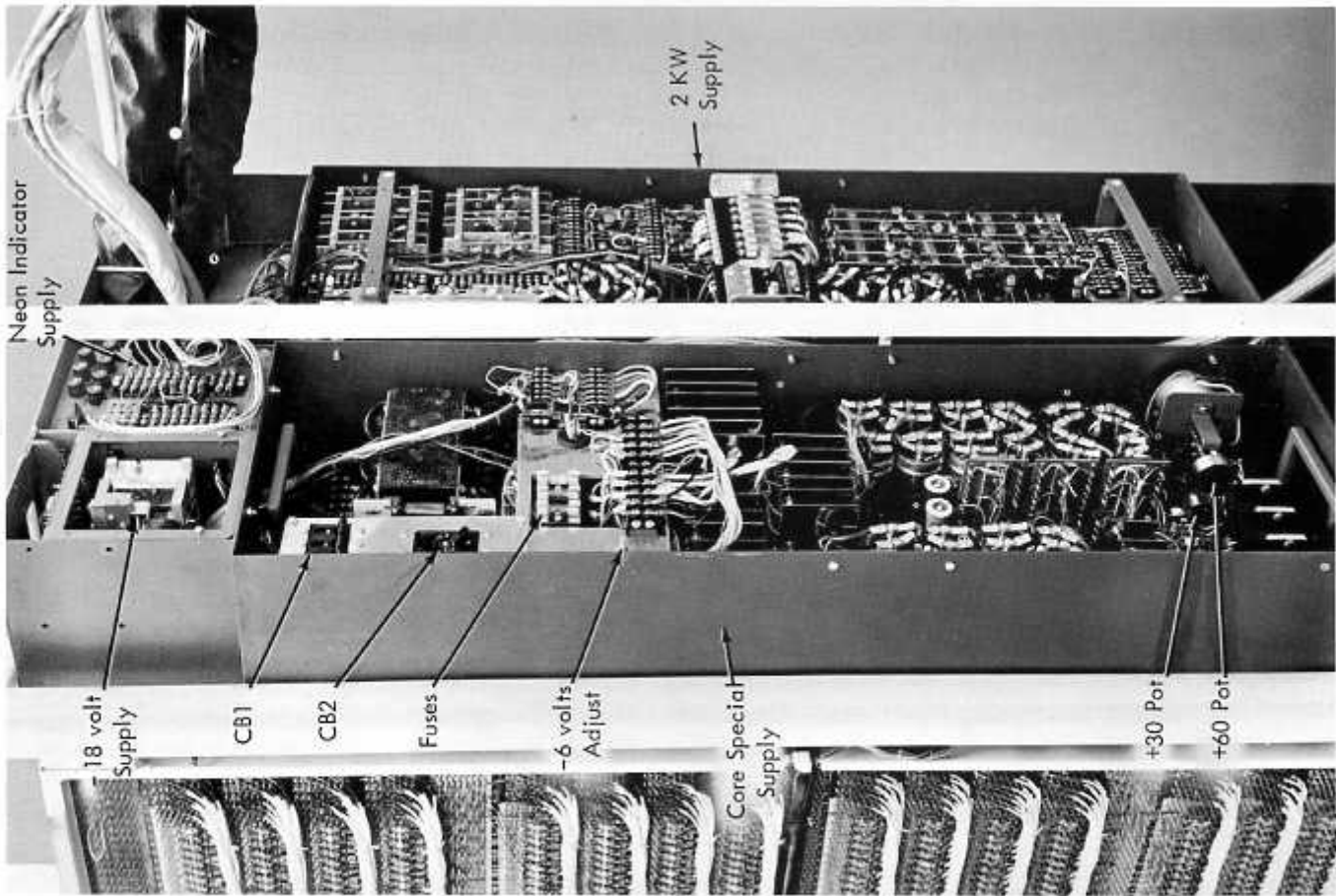

FIGURE 2.2-1. 7302 CORE STORAGE SUPPLIES - INSTALLED

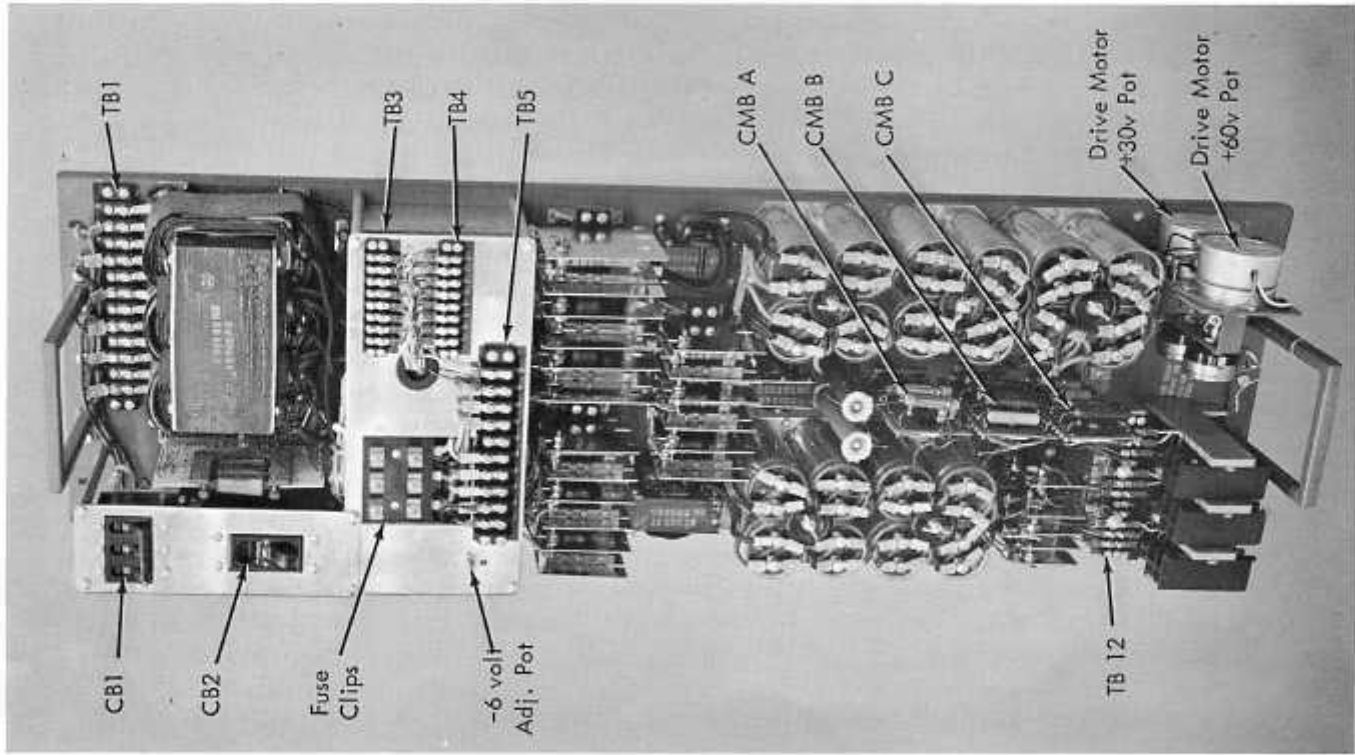

FIGURE 2.2-2. SPECIAL VOLTAGE SUPPLY - 3600 W

Both the +60 and +30v supplies can be varied for marginal testing by a motor-controlled potentiometer in the voltage control circuit. Motor controls are located at the console unit, while motors and potentiometers are located in the supply itself.

Two special purpose supplies develop voltages of +82v and -18v. The +82v supply furnishes power to neon detection circuits and is obtained by using a +22v supply whose negative side is tied to the +60v supply. The +22v supply is a standard full-wave rectifier. Input is from a tapped primary transformer T2. Output of the +22v supply can be varied from +20v to +25v in increments of 1v. Transformer T2 primary taps are brought out to a rotary switch, making it easy to vary the output. The supply is adjustable to allow for decay and variations in neon firing voltage.

The -18v supply furnishes power to CE panel indicators and is obtained by tying a -12v supply to the -6v supply. Output is not adjustable.

A transistor protection circuit is included in the power supply unit to drop power to the transistor drivers (CB2) if their bias voltage fails. Loss, or reduction, of bias voltage would allow the drivers to conduct continuously and ruin the transistors.

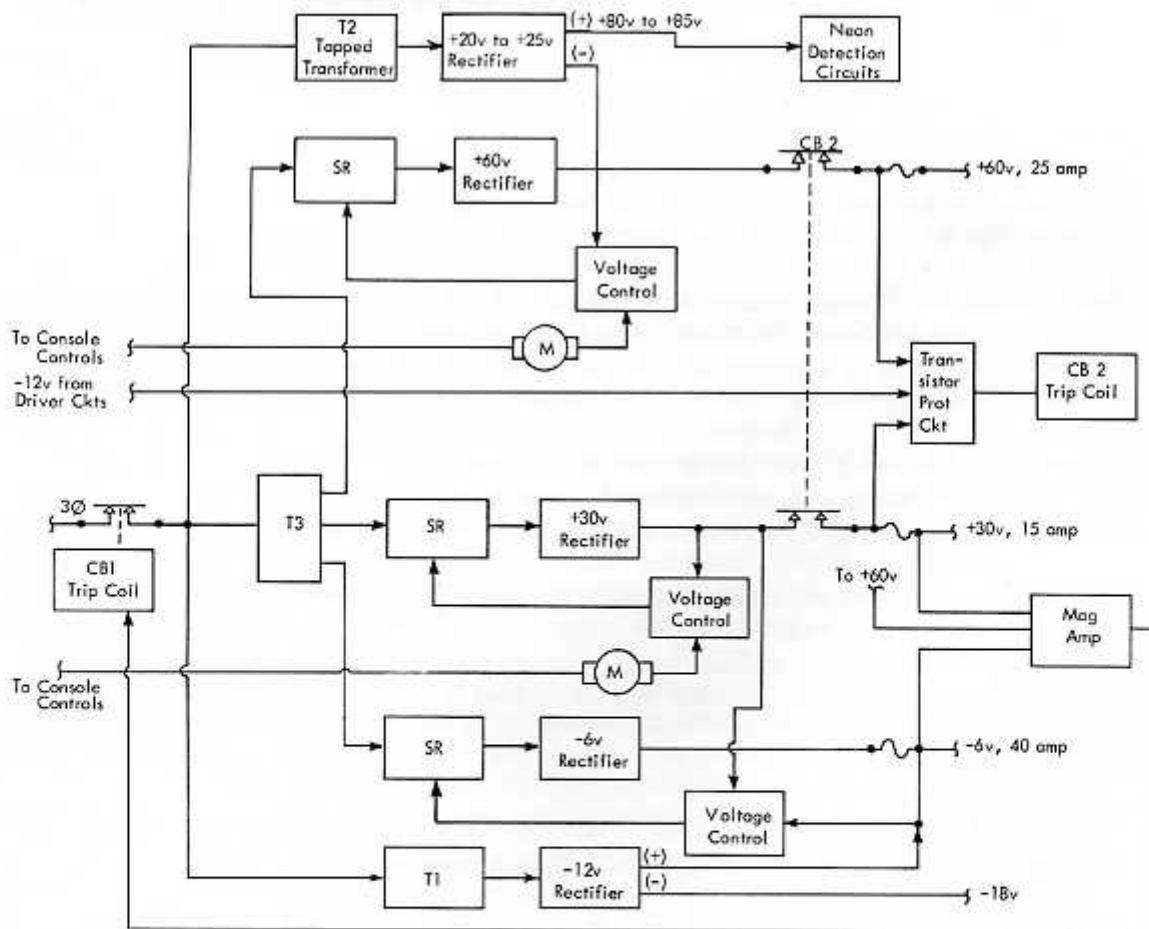

FIGURE 2.2-3. 7090 SPECIAL VOLTAGE POWER SUPPLY UNIT

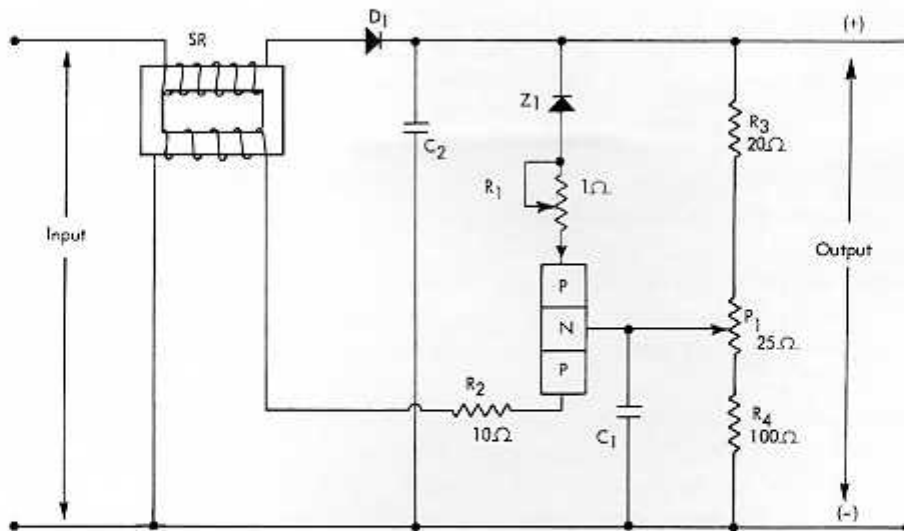

FIGURE 2.2-4. VOLTAGE CONTROL CIRCUIT USING ZENER REFERENCE DIODE

A magnetic amplifier circuit is used for open-fuse detection. If a fuse opens, the output of the magnetic amplifier energizes the trip coil of CB1 and drops power to the unit.

2.2.01 Zener Diodes as Reference Voltage Devices

A zener diode is a diode whose construction withstands zener breakdown repeatedly without harm to the diode. At zener breakdown voltage, current through the diode is limited only by the impedance of the circuit in which the diode is used.

Zener breakdown always occurs at the same voltage for a given type of zener diode. Because the voltage across the diode remains practically constant over a wide current range, it can be used as a voltage reference device.

Figure 2.2-4 shows a zener diode used as a voltage reference device. Rectifier output is controlled by a saturable reactor. The control winding to the SR is fed from a circuit which constantly checks the output voltage of the rectifier.

Reference voltage for the control circuit is a zener diode Z_1 . Resistors R_3 , R_4 , and P_1 form a divider across the output. The voltage across Z_1 , R_1 and tapped output of P_1 form the forward bias voltage for the transistor. If the output voltage increases, the bias on the transistor increases. The increased bias causes more current to flow through the transistor and the control winding of the SR, which lowers the voltage to the rectifier.

The regulated circuit shown is used in circuits where the load can vary over a wide range. The Z drivers in core storage are a typical example.

Input voltage to the circuit in Figure 2.2-4 is from the secondary winding of an input transformer. To develop special voltages, such as +60v, and +30v, it is only necessary to use different taps from the secondary winding of the input transformer.

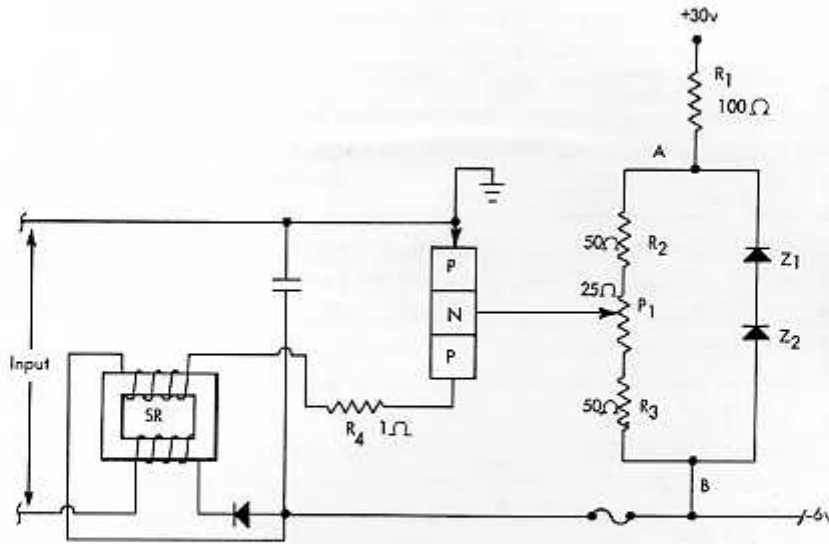

FIGURE 2.2-5. ZENER DIODES IN VOLTAGE CONTROL CIRCUITS

Figure 2.2-5 is another typical circuit using zener diodes as reference voltage devices. Diodes Z_1 and Z_2 drop approximately 10v across the load between points A and B. Because the 10v drop is in excess of the -6v supply, the circuit must be tied to some larger potential. The +30v was chosen because it is in the same power supply. The voltage drop across the zener diodes is given as approximate because the tolerances allow slight variations.

Under normal conditions, voltage across R_1 is 26v and point A is +4v with respect to ground. If the -6v supply should go to -7v, voltage at point A goes to +3v; as a result, voltage at any point along R_2 or P_1 goes slightly more negative. When point A goes in a negative direction, bias on the transistor increases, more current flows in the control winding of the SR, and output voltage is reduced. Conversely, if the -6v supply should go to -5v, point A would go in a positive direction, bias on the transistor would decrease, and output voltage would increase.

Note that the voltage with respect to ground at point A is determined solely by the voltage at point B, because the zener diodes always have about 10v drop across them. The +30v serves no function other than to obtain sufficient voltage to cause diodes Z_1 and Z_2 , to reach their zener breakdown voltage; variations in the +30v supply have no effect on the output or regulation of the -6v supply.

Voltage control circuits in this power supply using zener diodes and transistors are designed so loss of SR control winding current causes output voltage to increase. This increase does not damage the transistors. The circuit is designed this way because the most probable failure is shorting of a transistor, which allows an increase in SR control winding current and reduces output voltage.

2.2.02 Neon Detection Circuits

Detection circuits are included in the special core storage supply to turn on an indicator light if any core driver neon ionizes (turns on). Two detection circuits are used: one checks all X and Y core drivers; the other checks all Z drivers.

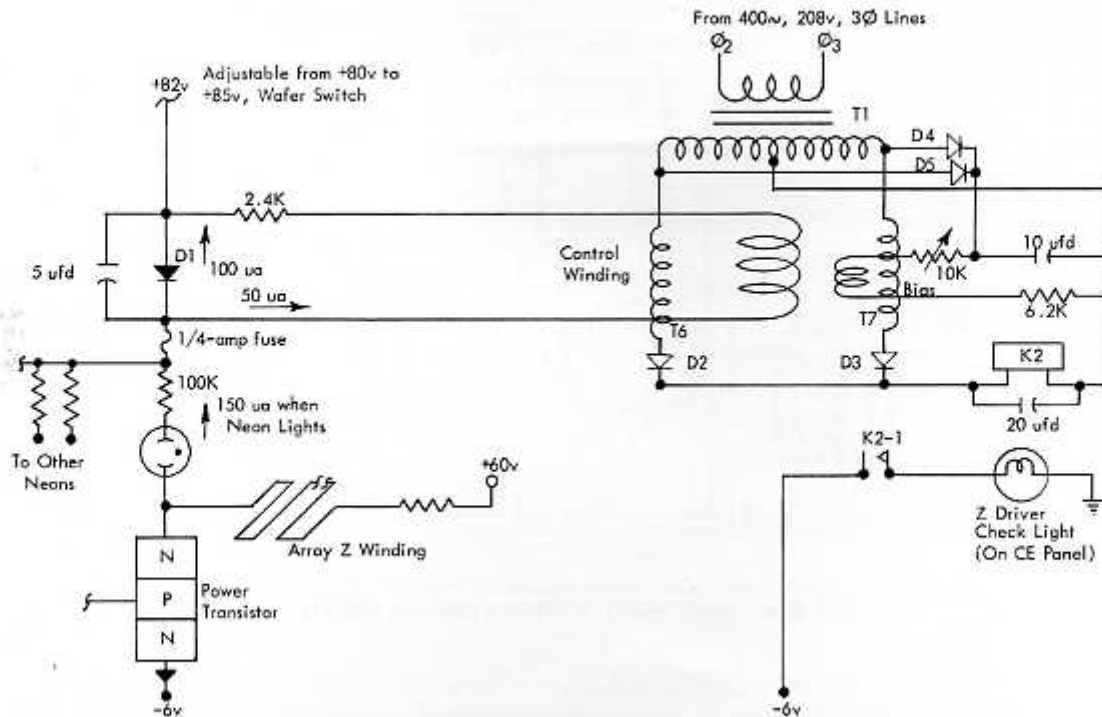

FIGURE 2.2-6. NEON DETECTION

The detection device is a magnetic amplifier which turns on with about 50 microamperes of current through its control winding (Figure 2.2-6).

One core driver power transistor is shown feeding the detection circuit. If the power transistor shorts and conducts continuously, the neon ionizes. In full conduction, the neon passes about 150 microamps (ua) of current. Diode D_1 and the magnetic amplifier control winding form a parallel circuit; the impedance of the two paths is such that 50 ua flow through the control winding and 100 ua through the diode.

Energizing the magnetic amplifier control winding with 50 ua of current saturates impedance windings T6 and T7. With T6 and T7 saturated the output is sufficient to pick relay K2 which remains energized as long as the neon is on. A K2-1 point in series with the Z driver check light turns the light on to indicate a shorted core driver.

A bias winding, energized through D_4 , D_5 , and a 10K potentiometer, is used to adjust the output of the magnetic amplifier. Because all diodes and components are identical, the bias is set to allow the relay K2 to pick when one neon is in full conduction. This is an indication only, as power is not dropped. Memory should be able to function until corrective action may be taken.

Diode D_1 is a control winding protection device. If a large number of neons lock on at one time, a large current would flow through D_1 and the parallel control winding. The forward characteristics of the diode are such that a large increase in current causes only a small increase in voltage drop across the diode. Because the impedance of the control winding remains constant and the voltage across it is increased only slightly, the current through the winding will not increase appreciably regardless of how many neons are on.

2.3.00 THE 2KW CORE STORAGE MODULAR SUPPLY (Figure 2.3-1)

The core storage module contains a modified SMS supply in addition to the special supply. The modified SMS supply is designed for a higher power output (2000 watts instead of the standard 750 watts). Only differences between this supply and the standard supply will be considered in detail herein.

First, the transformer arrangement is different (this was originally a 7070 supply). Buck-boost transformers are not used on the +30v and -36v sections, and the other transformers are numbered differently. Only two marginal check relays are used, one for +6v (all gates) and one for -12v (all gates). The magnetic amplifier differs in connections and in the resistors in some of the control windings, due to different loading.

The larger power output requires larger capacitors and 15 microhenry chokes for filtering the output voltage. The slow reverse recovery characteristic of the diodes generates spikes; eliminated by a de-spiking circuit using 0.1 microfarad capacitors across the diodes.

2.4.00 THYRATRON TRANSISTORS

The thyatron transistor (silicon-controlled rectifier) is a four element device with characteristics similar to those of a gas rectifier. As in a gas thyatron, there are two operating conditions. In the off (non-conducting) state, only leakage current flows. In the on state, current is limited only by the external circuit because the voltage drop across the transistor is about equal to that of one forward-biased PN rectifier. Firing is under control of a low impedance current source rather than a voltage source as in a tube thyatron.

Physical Properties

The thyatron transistor (PNPN) is constructed by diffusing two layers of P type material to a N type silicon wafer. An N type emitter is diffused on one of the layers of P material and a gate lead is attached to the same layer of P material. Figure 2.4-1A and 2.4-1B are two drawings of a PNPN thyatron transistor.

Electrical Properties

The characteristic curve of a thyatron transistor is shown in Figure 2.4-1C. Because of the shape of the characteristic curve, it is sometimes called a "hook transistor."

Consider a PNPN transistor without a gate lead attached. Applying V_c (Figure 2.4-1B) drives majority carriers toward the center PN section. With V_c of sufficient value, the center PN region becomes saturated with majority carriers and the energy of the carriers causes avalanche breakdown. Once breakdown voltage is reached, the current is limited only by the external circuit. Current flow through the transistor keeps all junctions forward-biased.

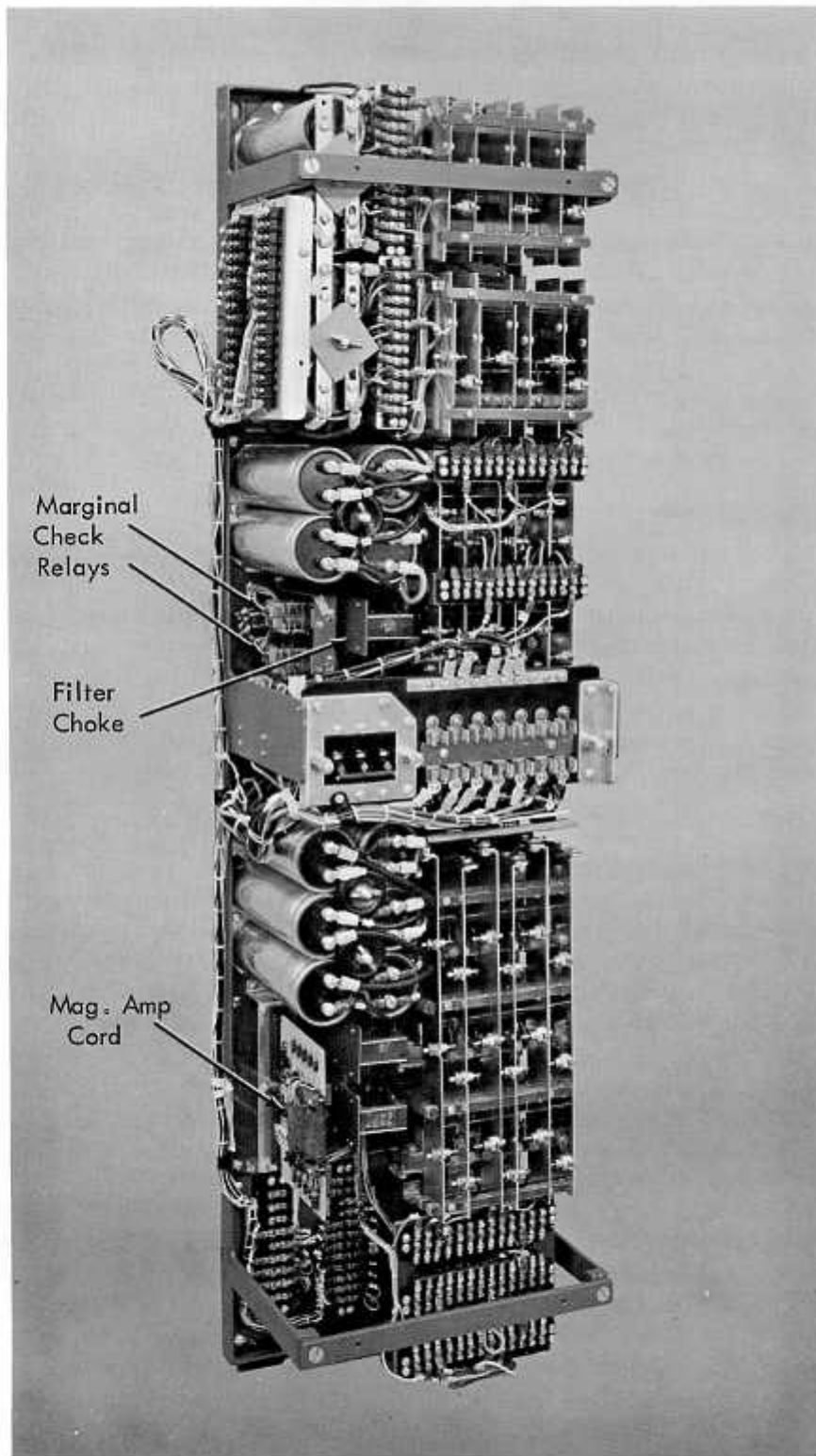

FIGURE 2.3-1. HEAVY DUTY MODULAR POWER SUPPLY - 2 KW

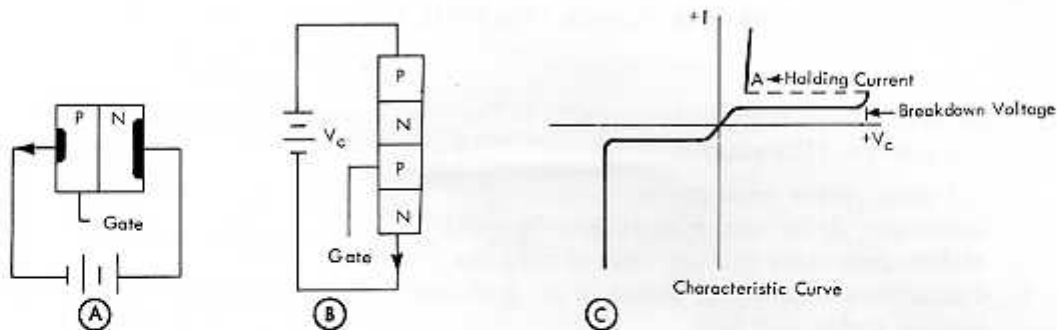

FIGURE 2.4-1. PNP THYRATRON TRANSISTOR

Few circuits are designed so voltage across the transistor can be varied; for this reason, a control, or gate lead is normally used. Feeding current into the gate lead causes saturation of the center PN region, and avalanche breakdown occurs at a lower value of collector to emitter voltage. Once the transistor is in conduction, the gate lead loses control. The only way the transistor can be turned off is to open the circuit or cause the current to be reduced below point A of Figure 2.4-1C. Point A is called the holding current, which is the minimum current, required to keep the center PN junction forward-biased.

Figure 2.4-2 shows a thyatron transistor as used in an actual circuit to protect driver transistors. The -12v is the bias voltage to a large group of drivers. If the -12v were lost, all drivers would try to conduct and burn out the transistors. The load in the collector circuit of the transistor is a circuit breaker which drops the collector voltage to the drivers. Two zener diodes (section 2.2.01) are used to set the gate lead voltage at about -1.5v. If the -12v should drop to -10v, the gate lead goes positive and the thyatron transistor goes into conduction.

A power transistor could be used in this same circuit but the safety factor would be lost. Approximately five milliseconds (ms) are required to trip the circuit breaker. If the -12v supply drops to -10v for a period of only two or three ms, the circuit breaker does not trip and intermittent errors will occur. The thyatron transistor will turn on if the -12v supply drops for only one to three usec.

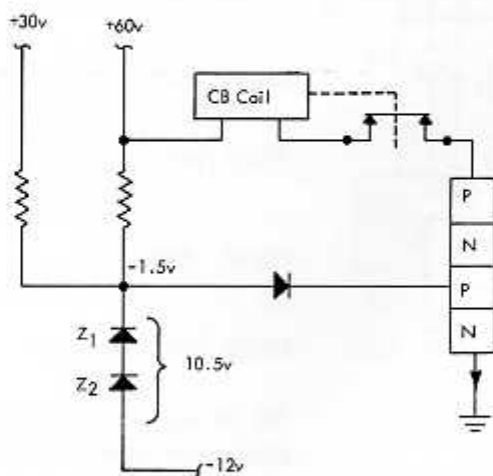

FIGURE 2.4-2. THYRATRON TRANSISTOR CIRCUIT

3.0.00 IBM 7618 POWER CONTROL UNIT

THE IBM 7618 Power Control Unit (PCU) is the 7090 system power control center. The PCU contains the following:

1. All main power contactors
2. Generator drive motor start-stop circuits
3. Motor-generator voltage control circuits
4. Contactors controlling power to all modular frames, including blower motor controls
5. Variacs for bringing system power up and for marginal checking
6. Convenience outlet overload circuit breakers
7. Timer motor for core storage blowers
8. Special voltage supply, 48 volts
9. Start-stop switches and circuits, voltmeter, and power reset key
10. Time delay relay to control core power off sequence

The PCU consists of one modular frame without slides or gates. All contactors and relays are mounted on special racks mounted within the modular frame. Each PCU function is described separately in following sections.

3.1.00 MOTOR-GENERATOR START-STOP CIRCUITS

Controls to start or stop the motor-generator (M-G) are located on both the console and the PCU. Figure 3.1-1 shows M-G start-stop circuits. The purpose of each key and its operation are given.

3.1.01 Power-On Key

Depressing the power-on key starts the M-G set and brings up power to the system in the following sequence (assume CB1 and HR29 are energized):

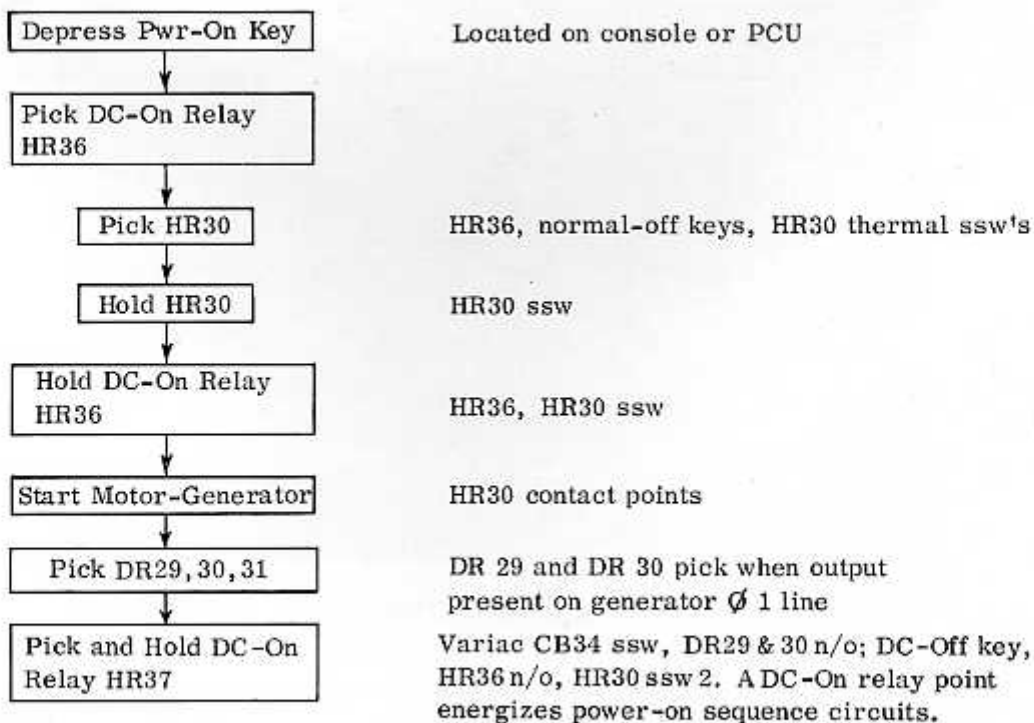

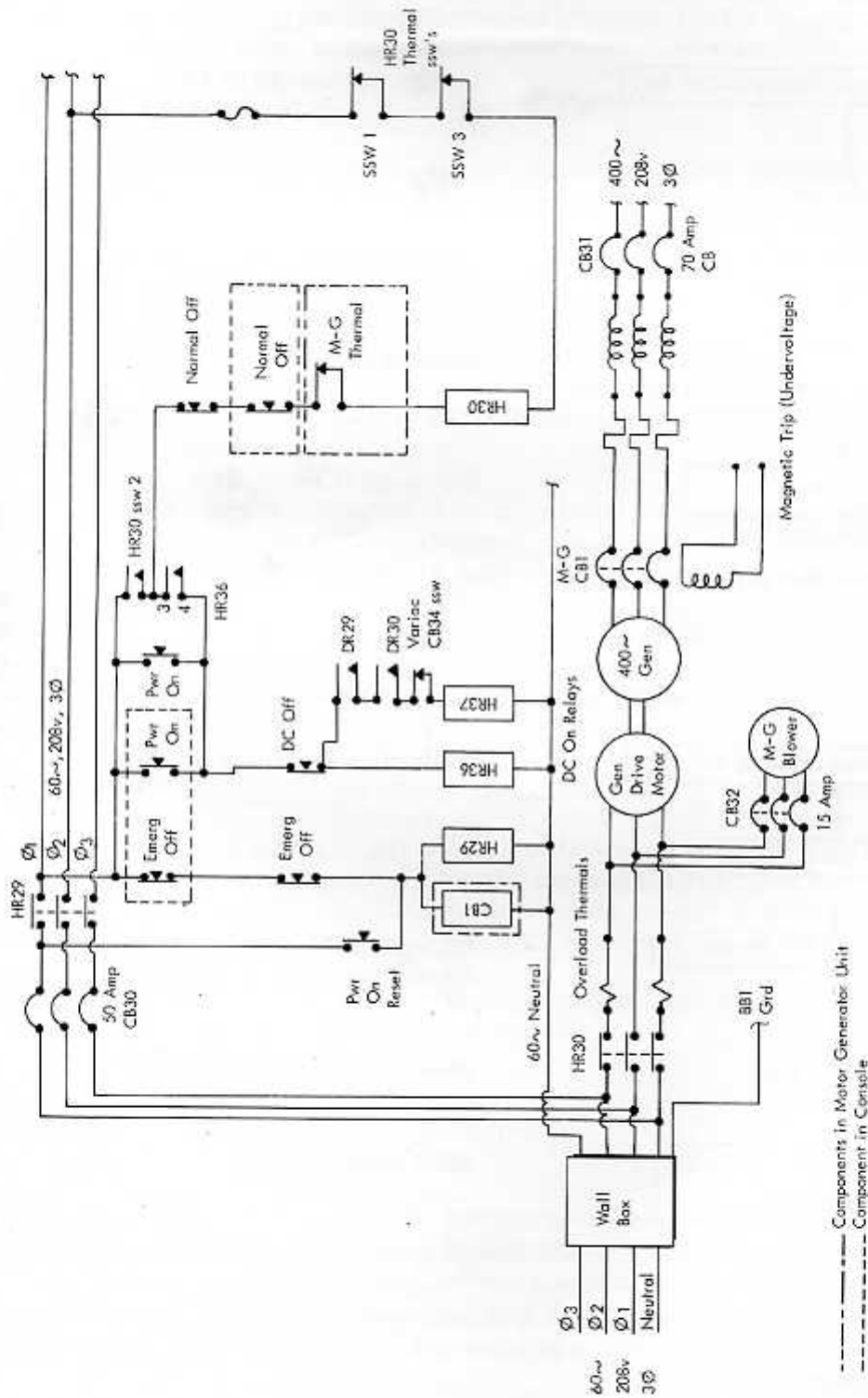
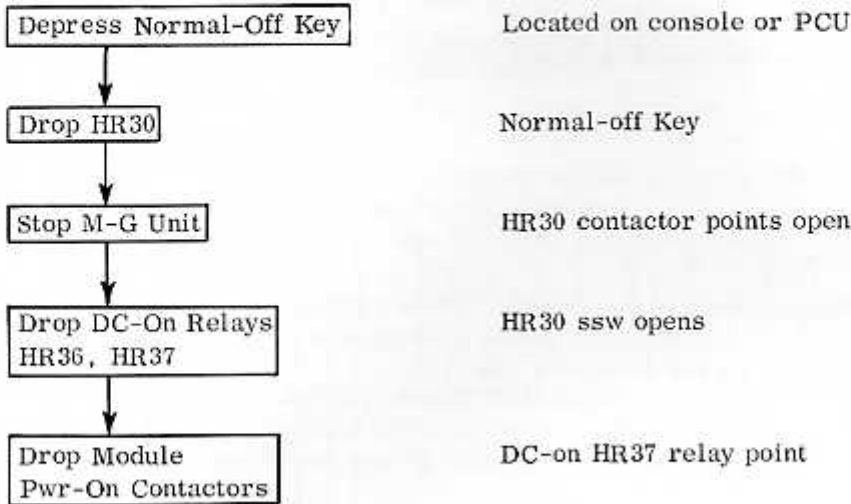

FIGURE 3.1-1. MOTOR-GENERATOR START-STOP CONTROLS

3.1.02 Normal-Off Key

Depressing the normal-off key drops DC power to all modules in the system and stops the M-G set.



3.1.03 Emergency-Off Key

Depressing the emergency-off key drops power to the system and stops the M-G set. Before power can be returned to the system, it is necessary to depress the power-on reset key in the PCU, and reset CB1 in the M-G set.

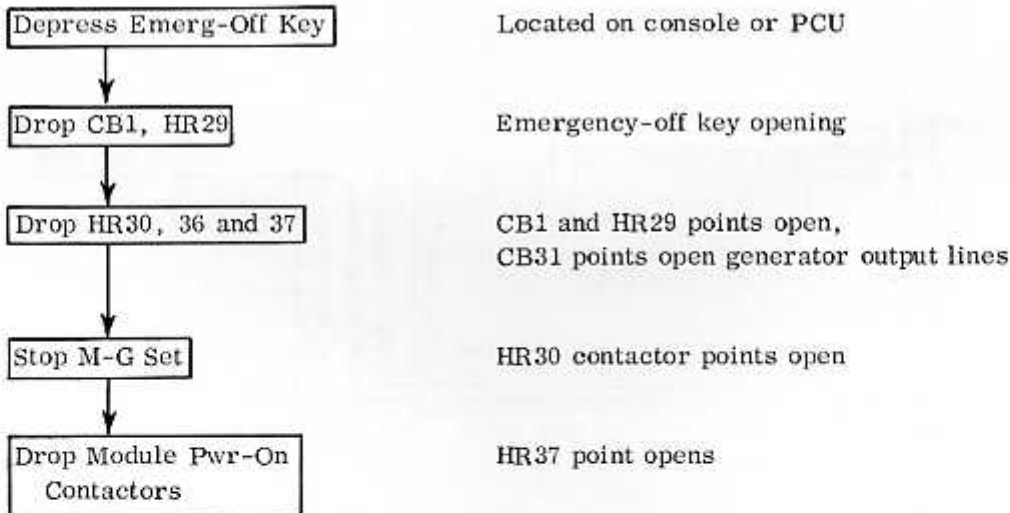

Because HR29 points are in series with all power-on keys, HR29 must be energized before any power-on key can be energized. Depressing the power-on reset key energizes HR29. CB1 (located in the M-G unit) must be manually reset to obtain an output from the generator. CB1 is an under voltage contactor which drops out if the incoming line voltage is lost.

3.1.04 DC-Off Key

The DC-off key drops 400-cycle power to the individual modules; the motor-generator continues to run. Depressing the DC-off key opens the circuit to the DC-on relays (HR36 and 37), dropping power to the modular power contactors because HR37 opens.

3.2.00 POWER-ON SEQUENCING

Power-on sequencing consists of energizing contactors for each SMS module in the system, then slowly raising the input voltage to the modules with a Variac.

The power-on Variac is driven both "up" and "down" by a motor. The Variac must complete two cycles before power is available to all portions of the system. The first Variac cycle brings power to all standard modular power supplies; the second Variac cycle feeds the special power supply in core storage. By using a second Variac cycle, core storage power drivers are prevented from conducting during power-on sequencing because all control voltages are stabilized before the driver collector voltage is added.

Figure 3.2-1 is a schematic diagram of the power sequencing circuits. Circuits shown are for two units; one is for standard modules and a second for core storage, which requires a second Variac cycle. All sequence circuits for modules other than core storage are similar to the standard circuit shown.

From the start-stop circuits, depressing the "power-on" key allows the DC-on relays to pick; the motor-generator starts and the output of the generator energizes DR31 (400-cycle interlock). See Figure 3.1-1.

Power-on Sequence

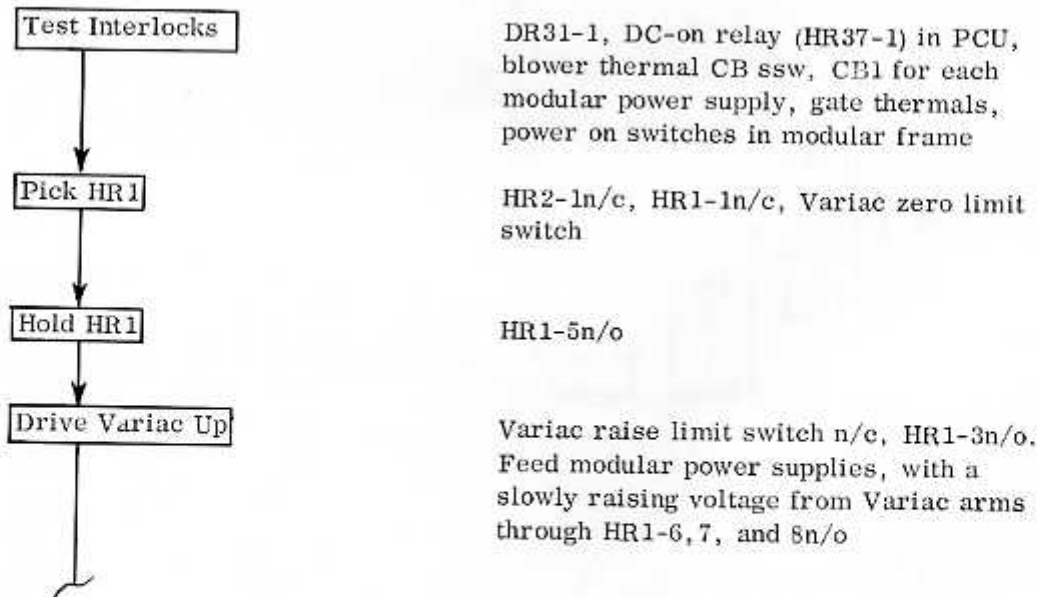

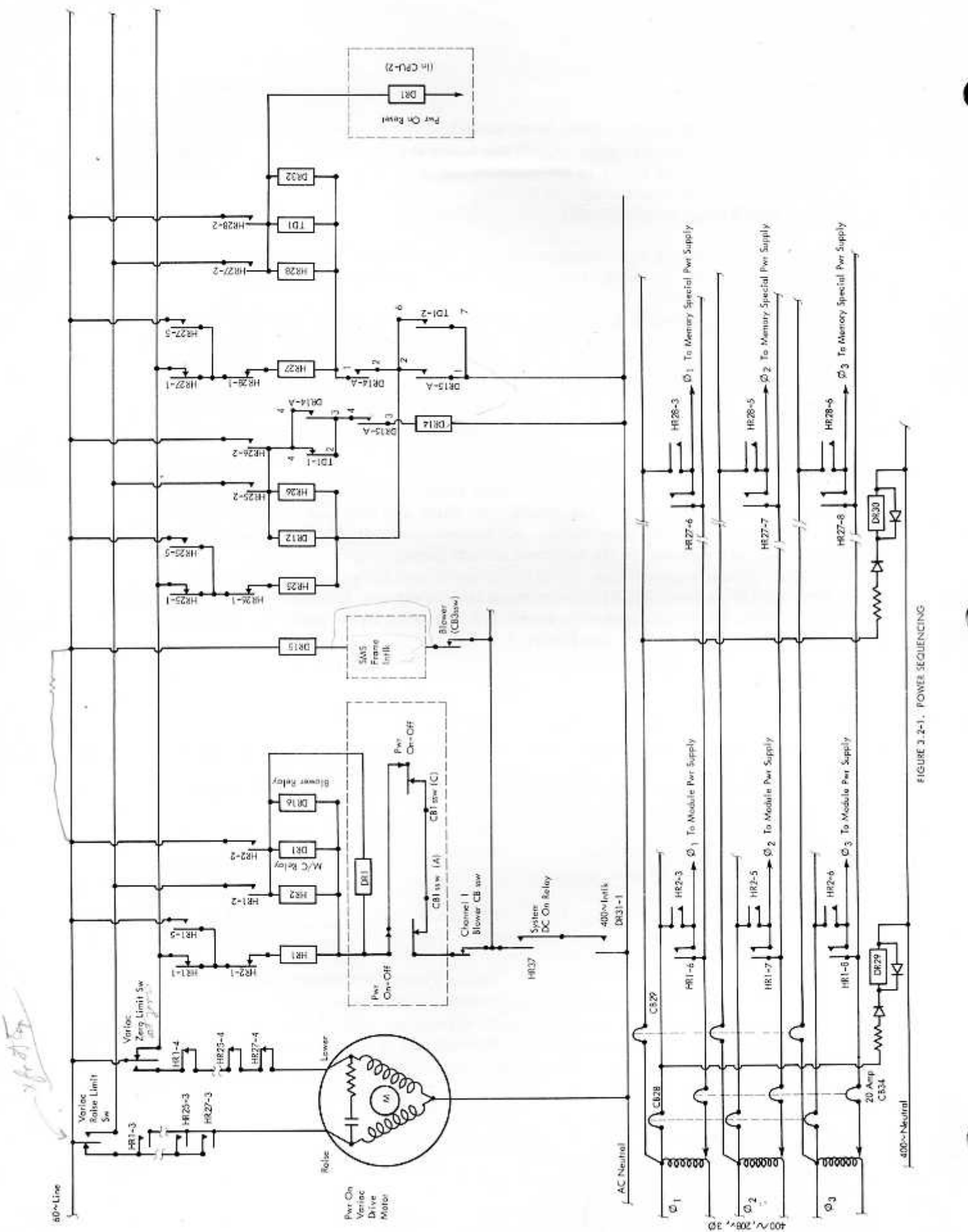
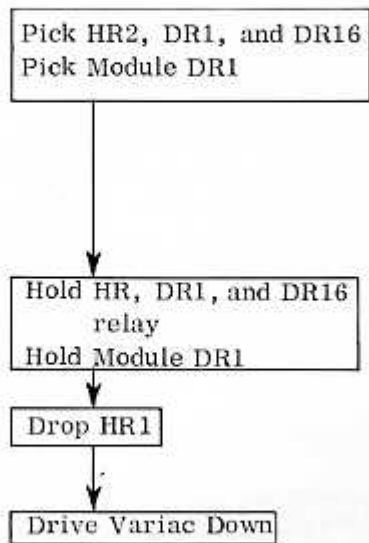

FIGURE 3.2-1. POWER SEQUENCING



Variac raise limit switch transferred, HR1-2n/o. Raise limit switch transfers when Variac has reached its upper limit. Apply full generator voltage to modules through HR2-3,5 and 6n/o. DR1 in modular frame interlock circuits turns on power-on-light on modular unit.

HR2-2n/o

HR2-1n/c

Variac zero limit switch transferred, HR1-4n/c. Zero limit switch transfers as soon as the Variac has moved off the 0 position.

When HR2 is energized, a marginal check relay (DR1) and a blower relay (DR16) pick in parallel with HR2. The blower relay starts the blower motors in the modular frame. The M/C relay points are in the M/C Variac lines to the modular supplies. If a fuse should blow while marginal-checking, the M/C relay points would remove the voltage to the buck-boost coil of the modular power supply rectifier circuit.

3.2.01 Core Storage Power-On Sequencing

Variac Cycle 1

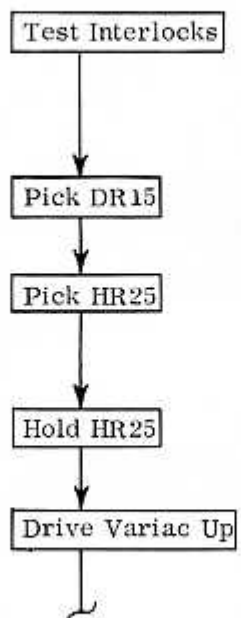

CB1 switches, thermals in gates, power switches in modular frame, core cooling interlock relay, and blower thermal CB ssw

HR26-1n/c, HR25-1n/c, Variac zero limit switch

HR25-5n/o

Variac raise-limit switch, HR25-3n/o

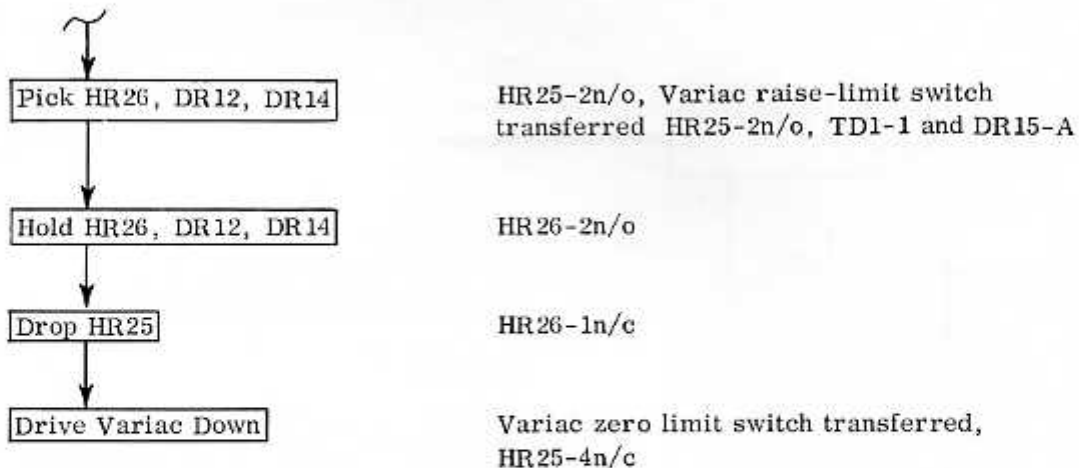

Variac Cycle 2

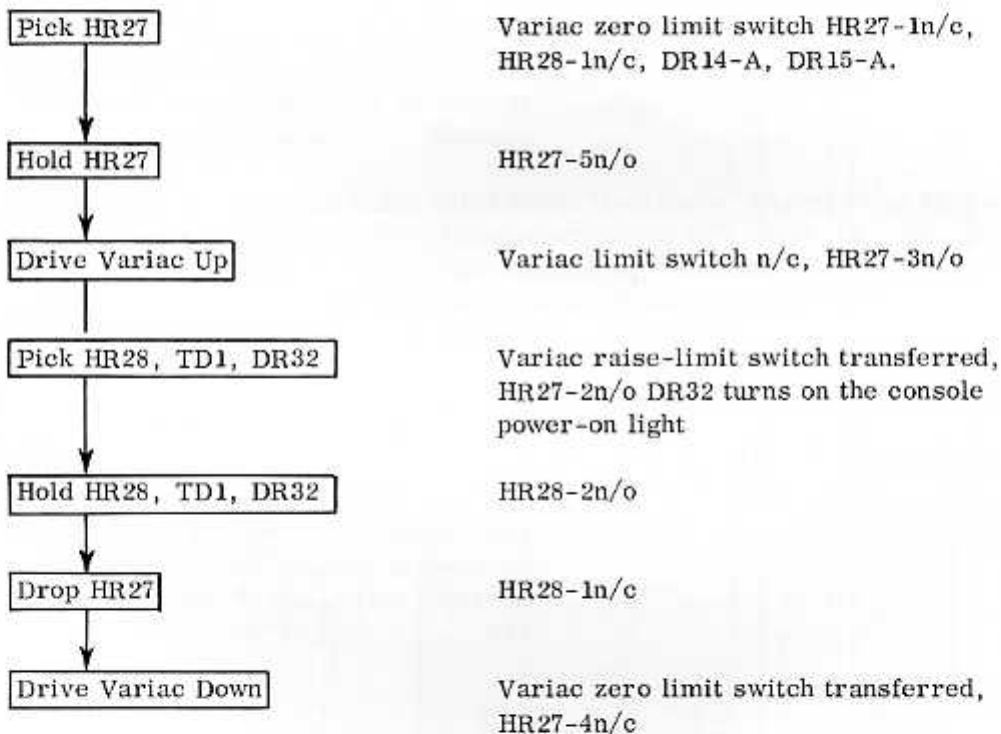

The first Variac cycle supplies power for all voltages in core storage except the +60v, +30v, and -6v driver supplies. The driver supply voltages are powered on the second Variac cycle.

When HR28 picked, DR32, TD1, and power-on reset relay DR1 picked in parallel with it; TD-1 sequences the power-off in the core storage unit, DR32 turns on the Power-On light on console, and CPU2 power-on reset relay DR1 initiates a system reset.

3.2.02 Core Storage Power-Off Sequencing

Core storage is the only unit using a power-off sequence. On a normal power-off or DC-off, the DC-on relays are dropped out which drops out the modular power contactors as shown in Figure 3.2-1.

In the core storage unit, it is desirable to drop voltage to the special power supply unit which feeds power driver collector voltage, before dropping power to the standard voltage unit. In Figure 3.2-1 the TD1-2 points continue to provide a circuit to hold HR26 for 5 seconds after DR15 and HR28 have dropped. The 5-second interval allows collector voltages to collapse before removing the bias voltages.

The delay in TD1 is accomplished by using an air dash-pot on the coil armature. The size of the dash-pot orifice determines the amount of delay.

3.3.00 BLOWER MOTORS AND CONVENIENCE OUTLETS

All blower motors and convenience outlets are protected by circuit breakers. The circuit breakers are mounted in the PCU and labeled by unit name. Figure 3.3-1 is a schematic drawing of the convenience outlets and the blower motors. In all modules except core storage, the blower relays are energized in parallel with the sequence contactors. When power is brought up, the blowers go on; when power is dropped, the blowers go off.

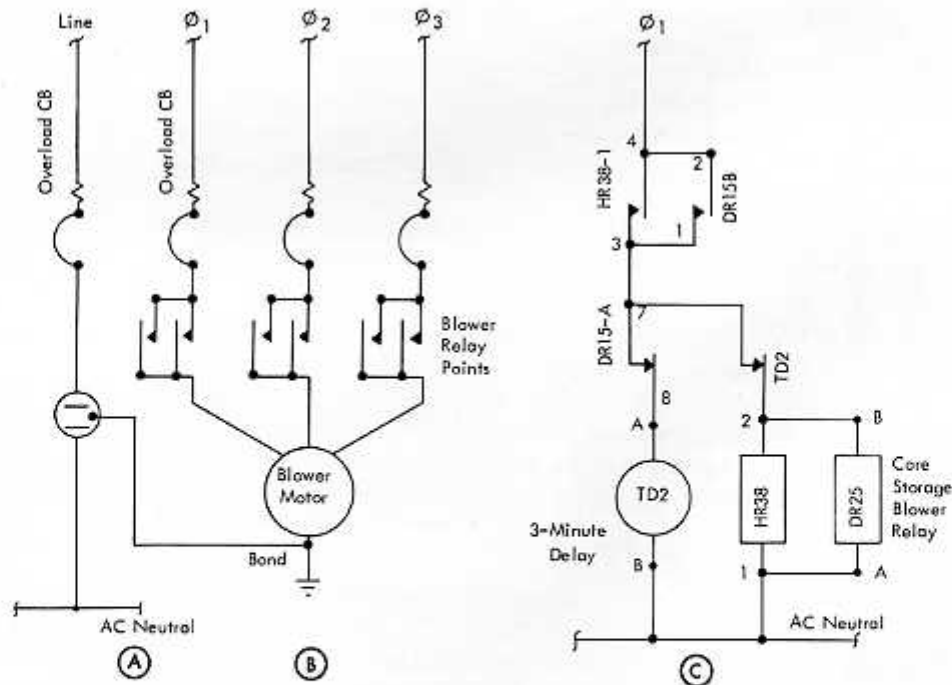

FIGURE 3.3-1. BLOWER MOTORS AND CONVENIENCE OUTLETS

Because of the power drivers, core storage dissipates a greater amount of heat; therefore, the blowers are controlled by a separate circuit (Figure 3.3-1C). When power is brought up, DR15 picks, which picks HR38 in parallel with the blower motor relays (DR25). When power is dropped, DR15 drops to energize time delay motor TD2. Three minutes after energizing TD2, the TD2 contact point opens to drop out HR38 and the blower relay.

An emergency power-off condition drops power to all units and blowers simultaneously, preventing any of the time delay circuits from operating; convenience outlets are also dead.

3.4.00 MARGINAL CHECKING

System marginal testing is performed with four voltages. Modular units in the system are marginal checked with +6v M/C and -12v M/C supplies. In addition, core storage core drivers are marginal checked with their +60v and +30v collector voltages.

All marginal check controls are located at the console (Figure 3.4-1). Marginal check Variacs in the PCU feed all units being tested, under control of keys on the console marginal check panel.

Lights on console indicate when +6 M/C or -12 M/C voltages are selected.

3.4.01 Marginal Checking, +6v, -12v

Marginal checking of the +6v or -12v is accomplished by either bucking or boosting the normal voltage by means of a Variac. The +6v or -12v supply may be varied $\pm 3v$. At these extremes, limit switches cut out any further variation of the voltage in that direction.

The +60v and +30v supplies are varied in much the same way as the +6v and -12v. The difference is that the +60v and +30v are varied by means of motor-driven potentiometers. The variance limit on the +60v is $\pm 6v$ and on the +30v it is $\pm 3v$. Limit switches on the motor prohibit varying the voltage beyond these limits.

The selection of the module units is under control of a group of keys on the panel. The keys are labeled MF 1, MF 2, MULTX, STOR, 1-8 (for channel frames), and CONS (console). These keys select the frames to be marginal checked. The keys to select the gates are in two groups, one for the +6v and the other for the -12v. They are labeled A, B, C, and D.

A selection, therefore, can be made to marginal check one, or all gates in any number of modules with either the +6v M/C or -12v M/C circuits, or both. Figure 3.4-2 is a schematic diagram illustrating the means used to marginal-check the system.

Owing to the power supply arrangement in the IBM 7302 Core Storage Unit, there is no choice but to bias all gates (A, B, C, and D) simultaneously. In this case, only the GATE A key is operative in each voltage group.

If the console (7151) is to be biased, all circuits using the variable voltage are affected at once. The GATE C key is the only one operative in each voltage group.

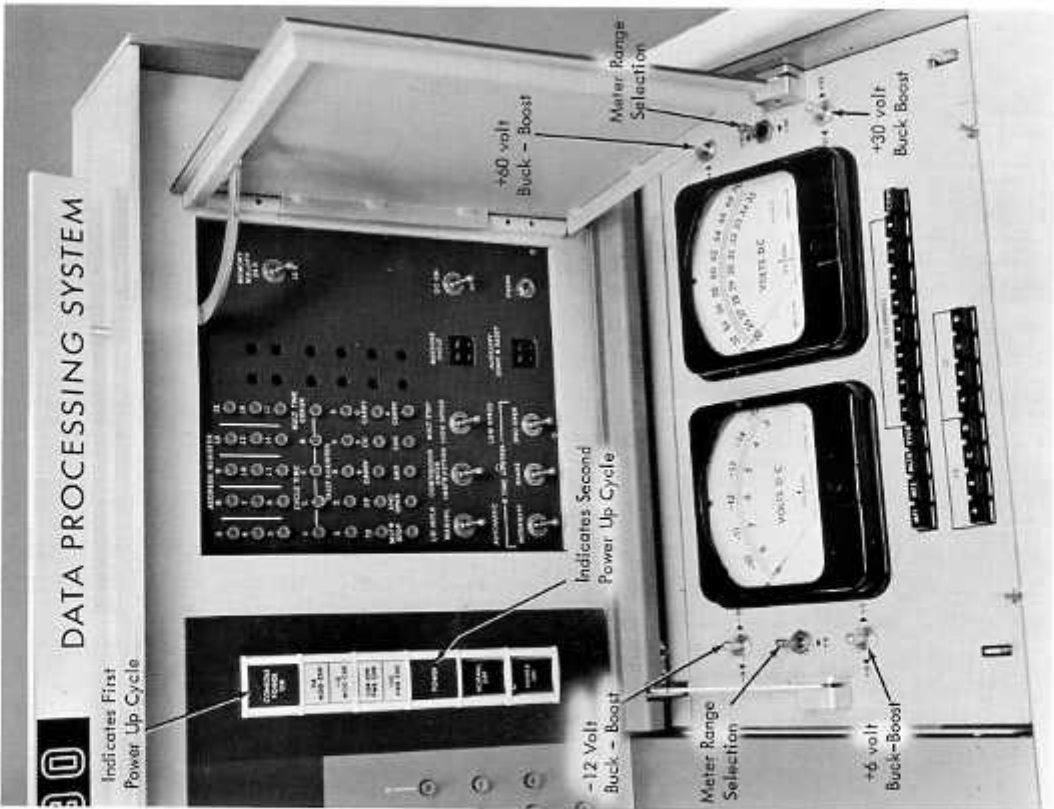
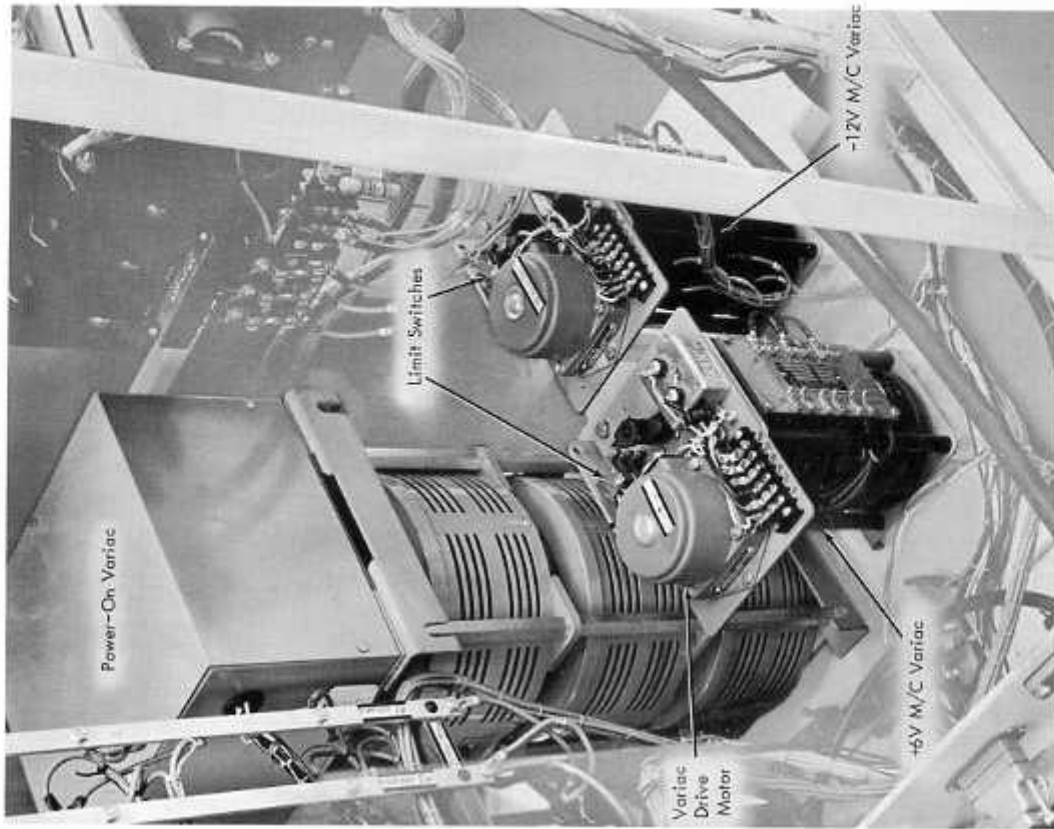

FIGURE 3.4-1. MARGINAL CHECK CONTROLS AND CONTROL VARIACS

TRANSFORMERS
to run
off center.

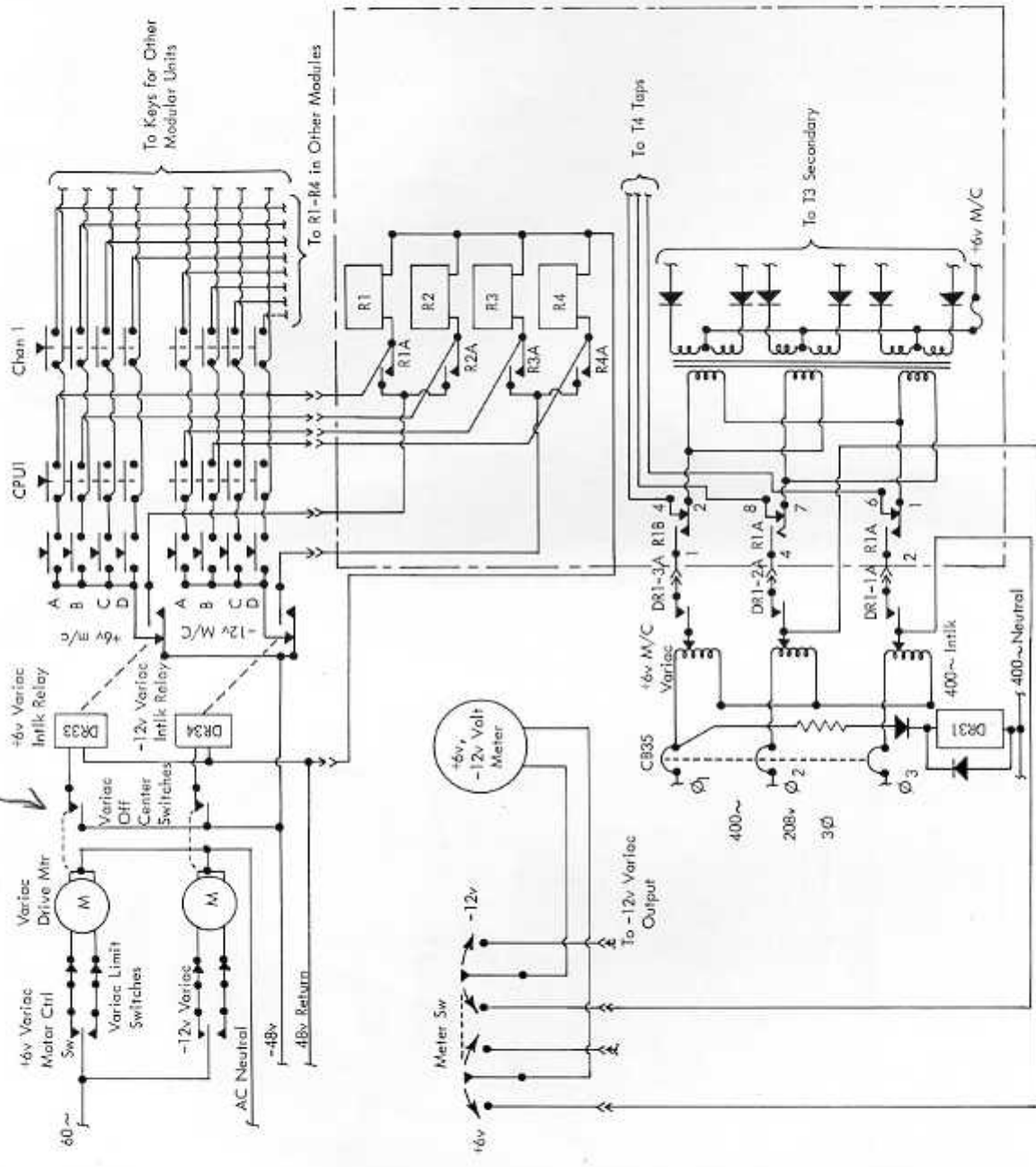

FIGURE 3.4-2. MARGINAL CHECKING +6v, -12v

NOTE: All keys signifying gates to be marginal-checked should be depressed prior to varying the voltage; they will be inoperative after a marginal check routine has begun.

Each of these two (+6v, -12v) marginal check voltages has its own Variac drive motor and interlock circuit. The switch to operate the Variac drive motor is located on the console M/C panel. Limit switches are wired in the Variac drive motor circuit to open the motor circuit when the variac has traveled to its limit. A Variac off-center switch is a mechanically operated switch. It is open only when the Variac is at its center position. When the Variac is at the center position, its output voltage to the modular power supply rectifier is equal to the voltage from the T4 tap.

The purpose of the off-center switch is to prevent the possibility of selecting a gate or gates for marginal checking when the Variac output voltage is already at a marginal voltage value. When the Variac off-center switch is closed, interlock relay, DR33 and DR34 pick to open the circuit to the marginal check selection keys.

Assume gate A of CPU1 is to be marginal-checked by varying the +6v M/C supply.

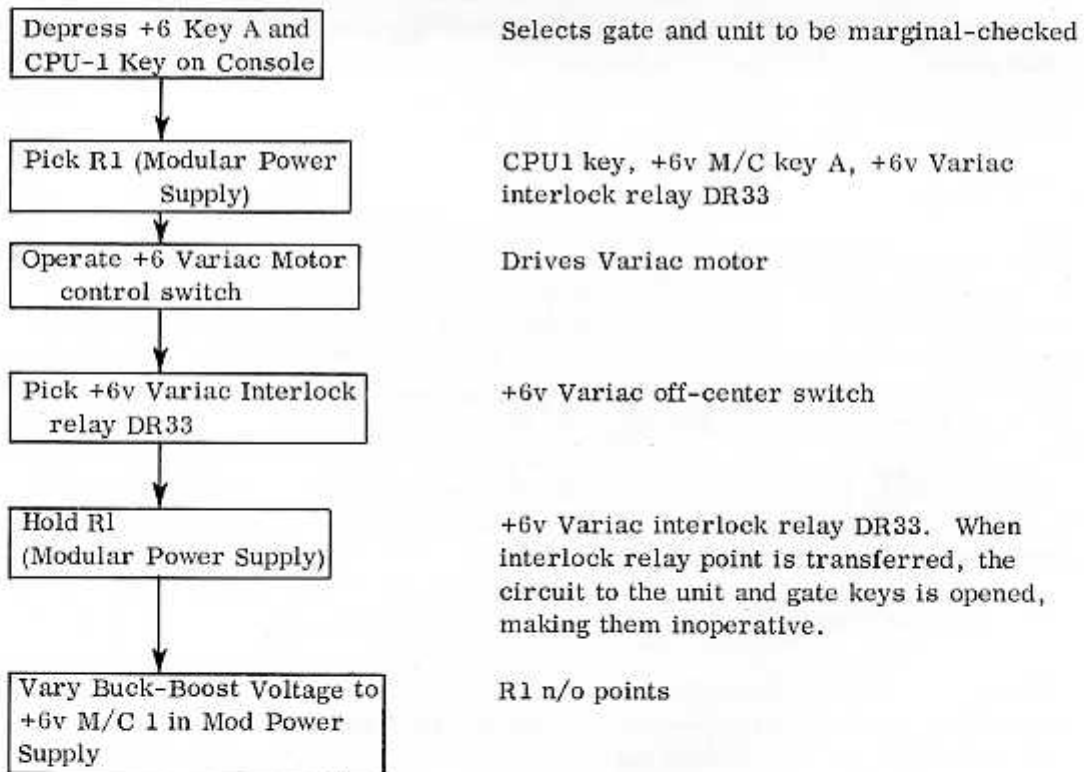

The +6v M/C supply meter is on the console. One meter records both the +6 and the -12v output; a switch controls which outputs is read (Figure 3.4-1). Note that the meter records the output of the Variac rather than the output of the supply. When the Variac is in the center position, output voltage is about 104v; the meter, however, reads either 6 or 12 volts, depending on the switch. As the Variac is varied during marginal checking, the output of the Variac varies around the 104v point; again, the meter converts this to a 6v or 12v reference.

In the center position, the circuit to the motor is open. To vary the voltage, the switch must be held to one side or the other. The voltage may be varied anywhere from +3v to +9v. The voltage varies for as long as the switch is held. When released, the Variac motor stops and the meter shows the present setting of the voltage. If the switch is held until the voltage reaches either +3v or +9v, the circuit to the motor is automatically opened.

Once the voltage has been varied either way from +6v, selection of any more frames or gates is interlocked for the +6v marginal check. This is to prevent a sudden surge or drop in voltage to any particular location.

To return the system to normal operation, set the +6v to its normal reading by means of the +9 --- +3 switch. The frame selection keys are released by pushing forward on the key.

If desired, all of the voltages to the selected frames may be biased at the same time. The -12v is controlled by the -15 --- -9 switch, the +60v by the +56 --- +66 switch and the +30v by the +27 --- +33 switch.

Although no change in module selection is effective for a voltage that has been varied, module selection is still operative for any voltage setting at its normal reading. This means that marginal checking of one voltage may take place in a particular section of the system, while another voltage is marginal checked in a different section.

3.4.02 Marginal Checking, +30v, +60v

Core storage marginal checking must include the checking of the special +30 and +60v special supplies. Switches to operate the potentiometer drive motors are located on the console. Changing the potentiometer setting changes the amount of forward bias on the control circuit transistor and varies the amount of current in the saturable reactor control winding. Care must be taken not to bias the +30v or +60v too high or for extended periods.

Relay circuitry is not involved in the biasing of the core storage special supply; +60v and +30v are each controlled by a motor-driven potentiometer, while the -6v supply is controlled by a manual potentiometer.

3.5.00 POWER CONTROL UNIT SPECIAL VOLTAGE SUPPLY

The power control unit contains a special -48v supply that operates all marginal check relays and the Variac off-center relay, and supplies power for all power-indicator lamps. It also supplies the bias voltage for the open fuse detection circuits in each module.

The -48v power supply is effectively two supplies OR'ed together, one operating from 60 cycles, the other from 400 cycles. The 60 cycle section has an output voltage of 42 to 43 volts, while the 400 cycle section is designed for 48 volts output.

Because the 400 cycle supply has the higher DC output, it will take the load in normal operation, due to back-biasing of the diodes in the 60 cycle supply. The 60 cycle section provides an adequate output when the 400 cycle power is off or varying due to the motor-generator set not being up to speed during power off and power on cycles.

The 400 cycle supply should be kept as close to 48 volts as possible. If the voltage gets low, the bias on mag-amp cards is reduced, and circuit breakers in the SMS frames may trip off intermittently. The voltage is adjusted by changing taps on the primary of the transformers.

DANGER: Always remove all power from the system by turning off the wall box before changing transformer taps.

3.6.00 POWER AND FUSE INDICATORS

Power and fuse indicator lights are mounted on the SMS frames. Two power check lights on the console are used for open-fuse indication. The two lights are:

1. Central computer power check light, which turns on if CB1 trips in CPU 1 or 2, core storage, the multiplexor, or the console.
2. I-O power check light, which turns on if CB1 trips in any of the data channels.

Figure 3.6-1 shows the means used to energize the power-on and power check lights. The power-on light in the SMS frame is energized when the interlock relay for that frame is energized.

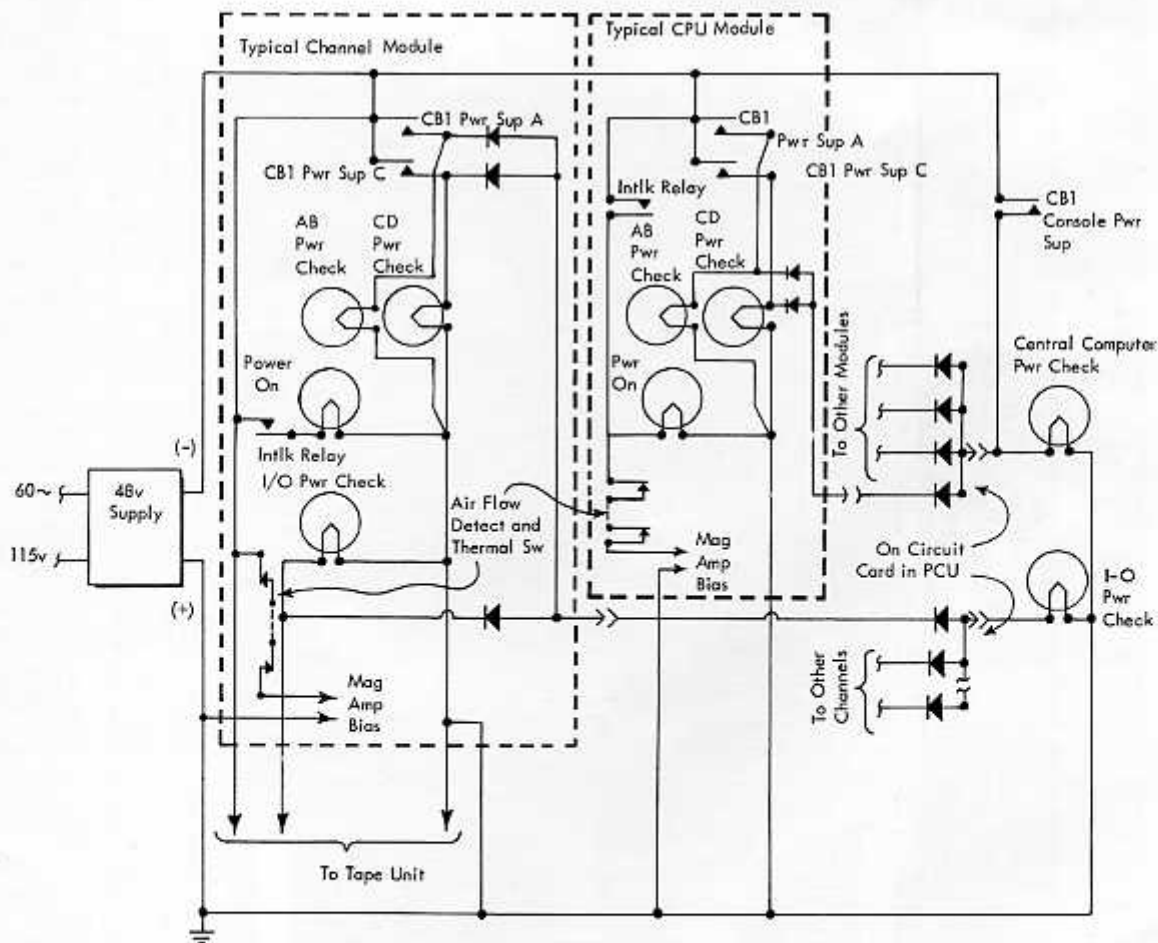

FIGURE 3.6-1. POWER INDICATOR LIGHTS

A blown fuse trips CB1. Tripping CB1 allows the CB1 points to close, energizing the blown fuse light. Most modules have two check lights, AB PWR CHECK light and CD PWR CHECK light, to indicate which tower has an open fuse. A parallel circuit through a diode energizes the power check light on the console. Note that the console does not have a separate fuse light to indicate a blown fuse in the console itself. If a console fuse blows, the central computer power check light comes on with the closing of the console CB1 point.

3.7.00 POWER CABLE DISTRIBUTION

Two power cables bring power from the PCU to the modular unit. One cable carries all 400~ power lines, the other carries all 60~ and DC power lines.

All cable connectors are located on one panel in the PCU (Figure 3.7-1).

Each cable connector is identified by unit; charts in systems further identify them by a letter or number designation. Individual connector pin numbers are printed on the face of the connector plug.

Receptacles in the modular units to receive the power cables are located at the lower rear of the machine, ahead of the lower tail gate. Above the receptacles is the modular unit interlock relay (DR1). All cables are labeled at both ends to indicate where the cable connects.

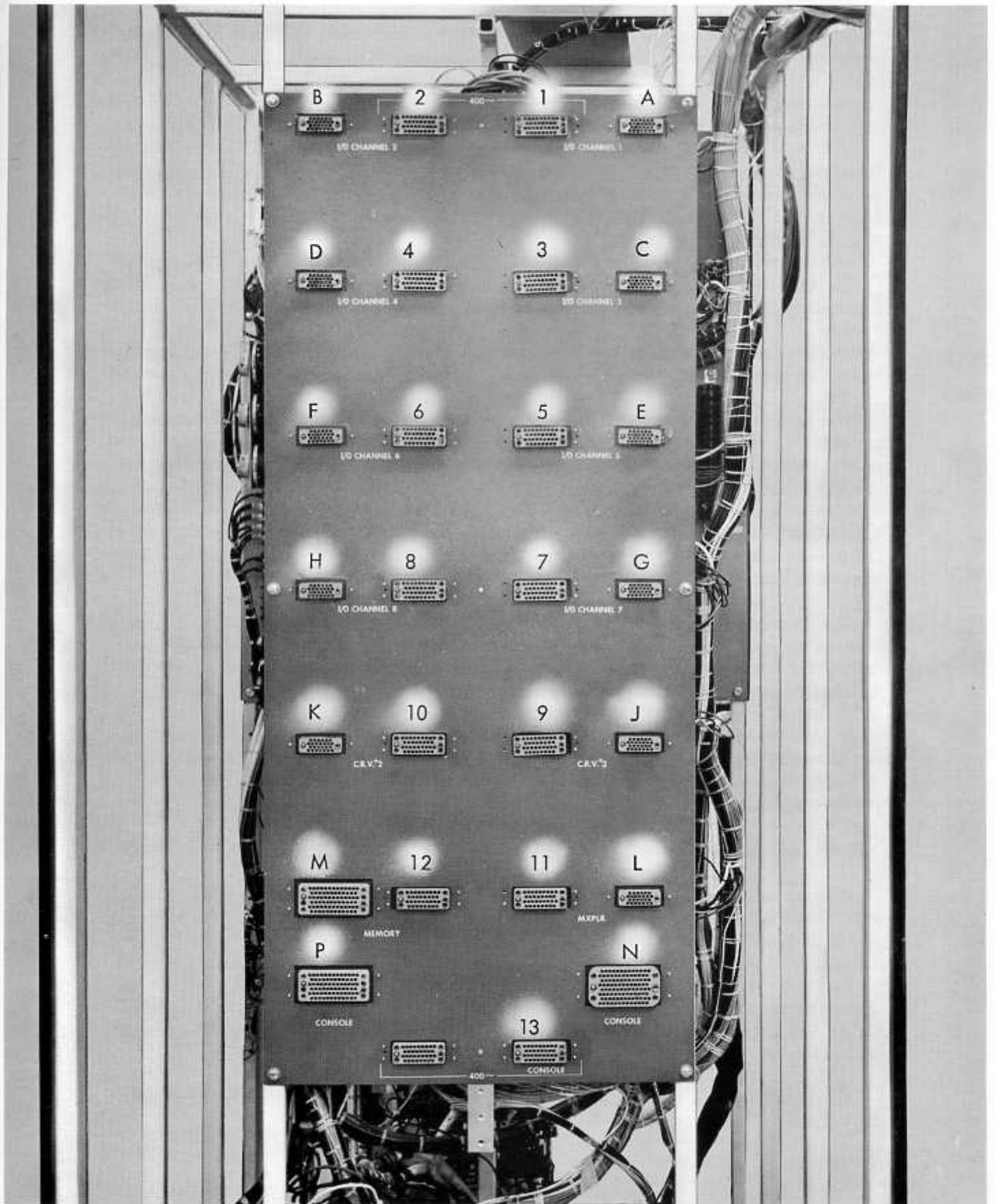

FIGURE 3.7-1. POWER CABLE DISTRIBUTION

4.0.00 CONSOLE CONTROLS AND INDICATORS

IN ADDITION to the various controls on the power control unit and the individual modules, several controls and indicating lights are located on the operating console.

4.1.00 CONSOLE CONTROLS

The console controls consist of three switches, power-on, normal-off, and emergency-off.

The power-on switch initiates a power-on sequencing cycle. Power will then be brought up in any module properly interlocked on the system.

The normal-off switch initiates a normal power-off cycle. Voltage cycles off in all the standard supplies and the core special supply first. The core 2 KW supply is dropped five seconds later and the blowers in core continue for three minutes after normal-off. The motor-generator stops.

A DC off switch is located on the CE panel section of the console. It turns off all DC power to the system, leaving test equipment receptacles active. The motor-generator runs but its output is opened in the power control unit.

The emergency-off switch is a pull-type switch used (as its name implies) only in emergency. All power to the system drops immediately, including power to the core heater and fan, and to the tape drives. The tape drive power drops because the interlock relays (DR-1) in channel are dropped.

In order to bring power back up, the power-on reset key must first be depressed on the power control unit. The motor-generator CB1 must be reset (dropped due to low voltage); then when the power-on switch on either the PCU or console is depressed, power-on sequencing will commence.

4.2.00 CONSOLE INDICATORS

Several indicator lights on the console serve to show the status of the power to the system, to indicate open fuses, to indicate temperatures beyond limits on core storage, and to show modular check voltages applied to the system.

The console power light shows that DC power is on in the console. This means that under normal power sequencing the power should be on in other modules at the same time. The only exception is the core special supply which comes on during the second half of the power-on cycle.

The power light on the console shows that the core special supply is on, as well as the core 2 KW supply.

The central computer power check (CCPC) light glows to indicate trouble conditions in CPU1, CPU2, multiplexor, or core storage. CPU1, CPU2 and multiplexor can turn on the CCPC light to indicate an open fuse, open thermal indicator in the gates or opening of an air-flow indicator switch. The CCPC light may be operated from core storage for an open fuse, open thermal indicator or core array temperatures outside of prescribed limits.

The I-O power check light glows to indicate an open fuse or open thermal switch in a data channel module. It is not affected by fuses in card machines or tape drives.

The +6 MOD CHK light glows to indicate that a +6 bias voltage has been selected on the CE bias panel, or that the bias Variac is still off-center from a previous bias condition even though bias select keys may have been restored.

The -12 MOD CHK light does the same thing for the -12 biasing that the +6 MOD CHK light does for the +6 volt biasing.

4.3.00 MODULE PANEL INDICATORS

A small panel on the upper part of gate A of each module carries a DC on/off switch and three lights. These lights are (1) a green light that is on when power is on in the particular module, (2) an A-B power check light indicating trouble in gate A or B and (3) a CD power check light indicating trouble in gate C or D. The latter two lights actually indicate that the input CB has tripped through any of several means: (1) open fuse, (2) open thermal sensing switch, (3) open air-flow detect switch, (4) open CB due to current overload on CB itself, or (5) trouble in the magnetic amplifier circuit.

The DC switch removes DC from the module when turned off and initiates a power-on cycle in the PCU to restore power when turned on. A second DC switch is located in the rear of each module. It is mounted on the frame to the left of gate E (facing the gate) as a convenience and safety precaution. It is in series with the front DC switch and therefore has the same action.

5.0.00 POWER CONVERTER

A 60-cycle, 208v, 3 ϕ motor, driving a 400-cycle, 208v, 3 ϕ generator is used as a power source for the 7070-7090 converter power supplies. Advantages of a 400-cycle power source are reductions in size of components such as transformers and saturable reactors and in the amount of filtering required to maintain an output voltage with a low ripple content.

Two types of generators are used, brush type and brushless (self-exciting).

Brush type generators are controlled by regulating the current in the rotating field winding. Current to the field winding is fed through slip rings on the rotating shaft. Output voltage increases with field winding current within the operating range of the generator.

Self-exciting generators use a small alternator (exciter) attached to the rotating shaft. The exciter has a stationary field fed from an external source. The output of the exciter feeds directly into the rotating field windings of the generator. No slip rings are required when an exciter is used, eliminating a possible source of failure. Generator output voltage increases with an increase of exciter field winding current.

5.1.00 MOTOR-GENERATOR VOLTAGE CONTROL

Voltage regulation for the power supply system is accomplished by regulating the output voltage of the generator. Figure 5.1-1 shows generator voltage control circuits; these circuits serve two functions:

1. To flash the generator field winding to assure generator output voltage
2. To control (regulate) generator output voltage and dampen (smooth out) transient voltages on the generator output

5.1.01 Field Flashing

Development of output voltage from a generator depends on the presence of magnetic flux in the field winding. Most small generators rely upon residual magnetism in the field winding core to supply this flux; if this residual magnetism is lost, the field must be flashed (energized for a short period of time) from a DC source before an output can be obtained from the generator.

A field-flashing circuit (Figure 5.1-2) is built into the motor-generator control circuits. Transformer T3 and rectifier A feed current through relay CR1 n/c points to the field winding of the generator. As the generator builds up voltage, transformer T1 and rectifier B generate a voltage across R_G and the coil of relay CR1. When generator output voltage reaches about 200v, the relay energizes and the CR1 points in the flashing circuit (output of rectifier A) open. The control circuits then energize the field winding.

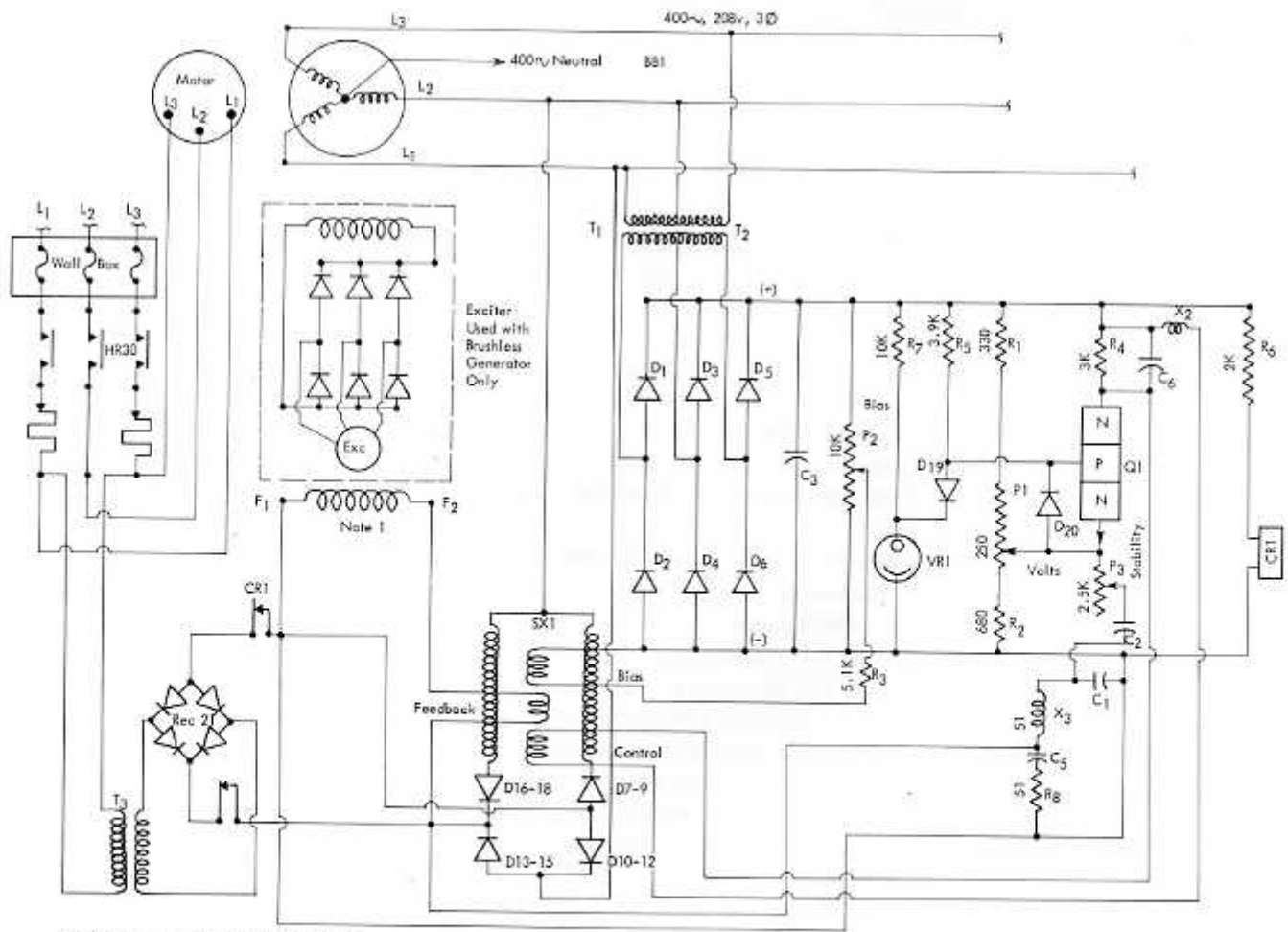
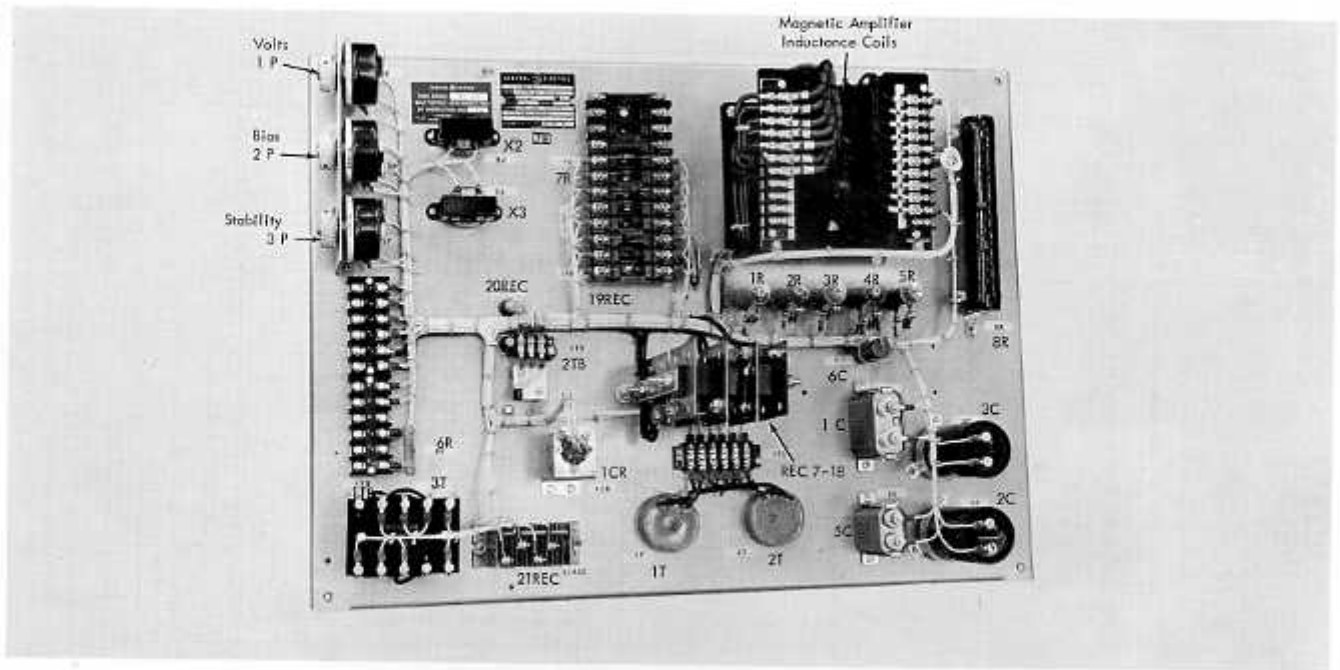

Note 1: Coil F₁ - F₂ = Generator Field Coil,
Brush Type Generator; Exciter Coil;
Brushless Generator

FIGURE 5.1-1. MOTOR-GENERATOR EXCITER AND REGULATOR

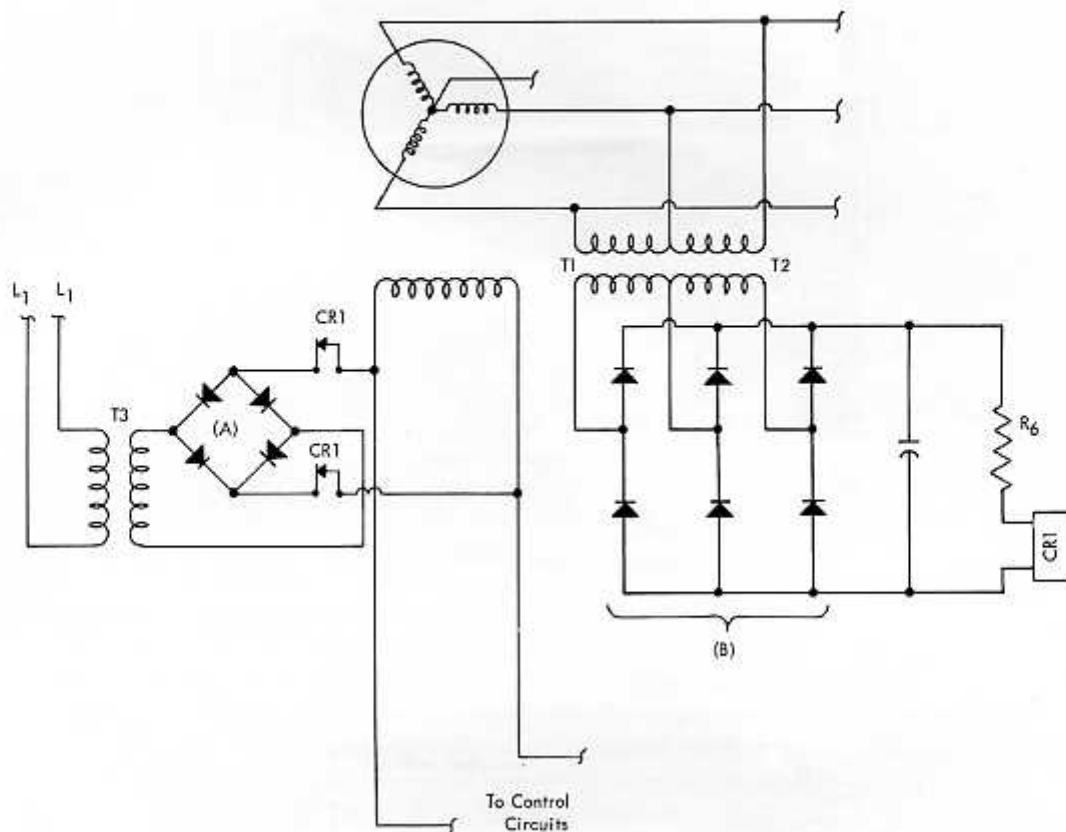

FIGURE 5.1-2. FIELD FLASHING

5. 1. 02 Output Regulation

Voltage control circuits (Figure 5. 1-3) maintain a constant generator output voltage.

Under normal operation the input voltage V_{in} (from the generator) is constant. A voltage regulator (VR) tube serves as a reference voltage for the system because the voltage drop across it remains constant for a wide range V_{in} .

The voltage drop across diode D_{19} is small enough in comparison to the drop across R_5 that it can be ignored; as a result, the voltage V_c at the base of the transistor is nearly constant. Resistors R_1 and R_2 and potentiometer P_1 form a voltage divider across the line (V_{in}); the tapped output (V_B) of P_1 feeds the transistor emitter. With a variation in V_{in} , the voltage V_B increases. The emitter and base voltages of the transistor determine the bias which is actually a comparison of the two voltages. The output of the transistor is fed through the control winding of the magnetic amplifier. Components X_2 and C_6 form a filter for the magnetic amplifier control winding. Negative feedback (damping circuit) to control transients and prevent hunting is controlled through P_3 , C_2 , and field winding filter C_1 and X_3 .

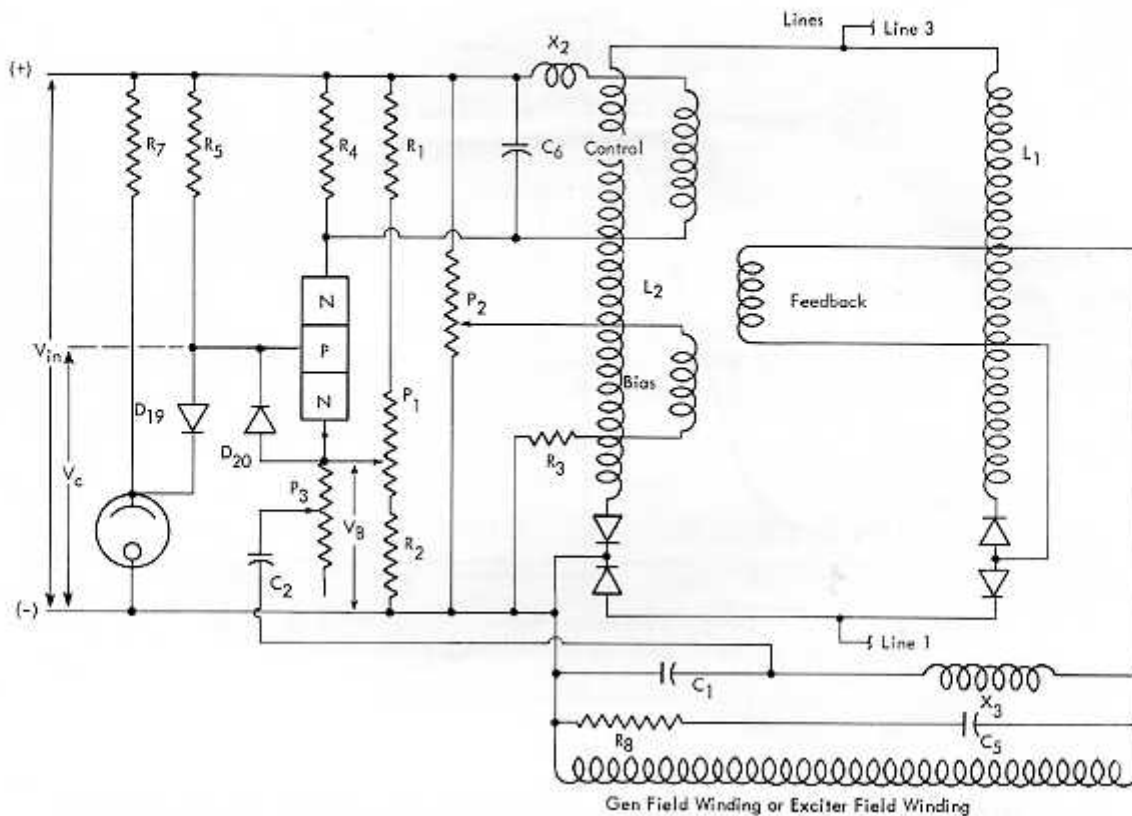

FIGURE 5.1-3. GENERATOR DAMPING AND CONTROL

Consider the case where the output voltage of the generator increases. Voltage across VR_1 remains constant while the voltage level at the tapped output of P_1 increases; thus, the bias on the transistor decreases. Decreased bias on the transistor results in reduced current flow in the control winding of the magnetic amplifier.

Bias to the magnetic amplifier is produced by P_2 and R_3 (Figure 5.1-4). Characteristics of the amplifier are shown in Figure 5.1-4. With the control winding open, the operating point of the B-H curve, due to the bias winding, would be at point A. With normal operation and current flowing in the amplifier control winding, the operating point would be at point B. When V_{in} increases, with a resulting decrease in current in the magnetic amplifier control winding, the operating point moves to point C; as a result the current through the generator field winding is reduced, and generator output drops to its controlled level.

Operation is similar with a drop or decrease of V_{in} ; bias on the transistor is increased, more current flows in the control winding of the magnetic amplifier, and generator field current increases to raise the output voltage.

The feedback winding of the magnetic amplifier (Figure 5.1-3) is wired for positive feedback. The result is a steeper slope of the characteristic curve, as shown by dotted lines in Figure 5.1-4. The steeper the curve, the closer the voltage regulation.

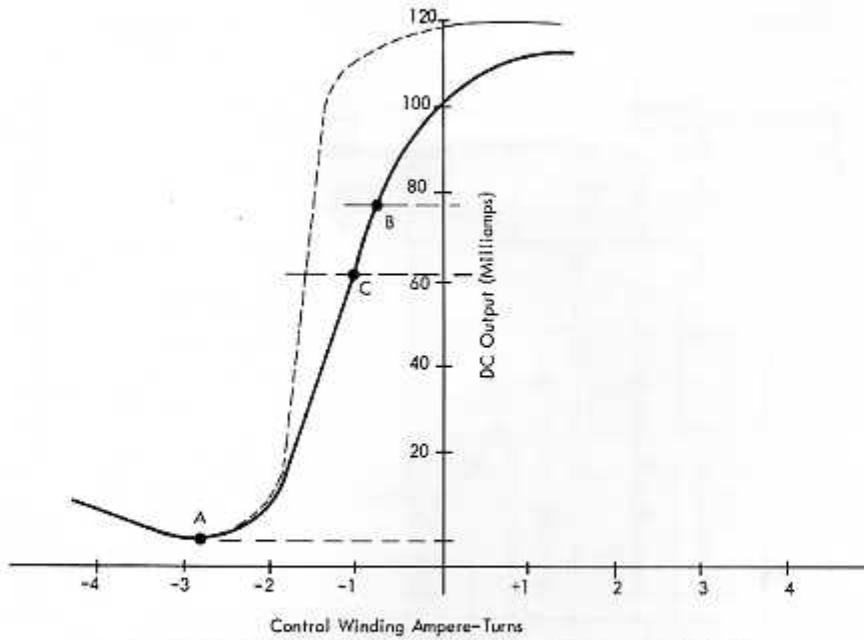

FIGURE 5.1-4. MAGNETIC AMPLIFIER CHARACTERISTICS WITH FEEDBACK

Diode D19 (Figure 5.1-3) is a temperature compensating diode. As temperature increases the voltage drop across VR1 increases; however, the forward resistance of the diode will decrease. The result is a constant voltage on the base of the transistor. Diode D20 is a transistor protection diode; it prevents excessive emitter-to-base reverse bias voltages from damaging the transistor.

6.0.00 VOLTAGE SUPPLY, IBM 729 MAGNETIC TAPE UNIT

A 7090 tape unit receives its input power (208v, 60 cycle, 3-phase) through connectors on the data channel module. It may, however, be powered directly from wall outlets when not used with the system. Power into the tape unit is controlled by a power on/off switch on the back of the individual tape unit and through the interlock relay (DR1) in the data channel to which the tape unit is attached. Three phase power is used to run the motors, and the DC power supply input is drawn from phases 1 and 2. Figure 6.0-1 shows the power input configuration.

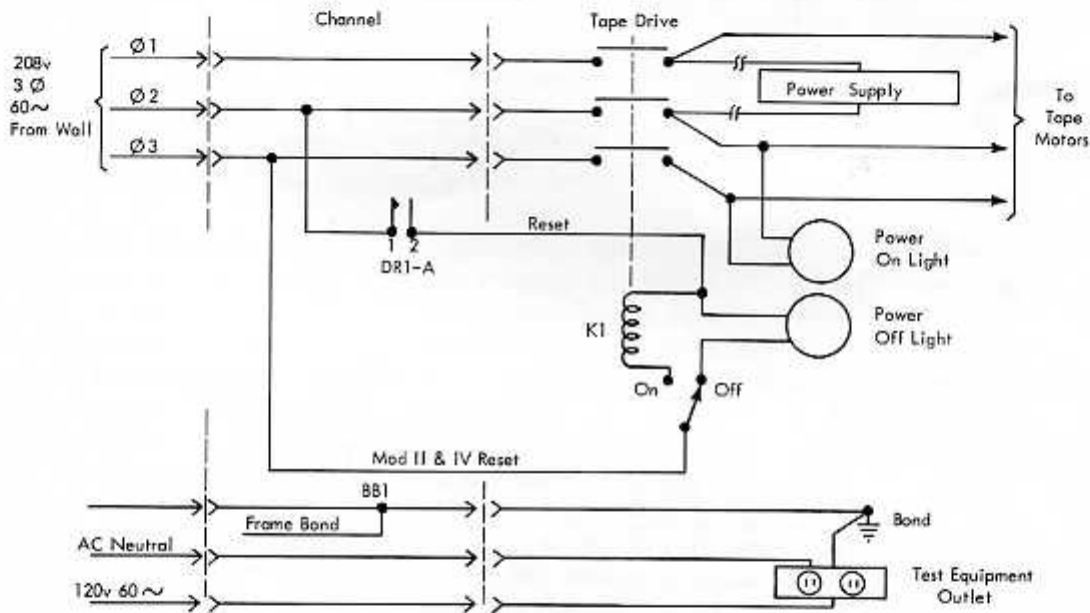

FIGURE 6.0-1. TAPE UNIT POWER

6.1.00 MAGNETIC TAPE UNIT DC SUPPLY

The tape unit DC supply is a 60 cycle transistor-controlled power supply. The circuits are found in the tape unit Systems 03.10.1, and typical circuits are covered herein. (Further information on such a supply may be found in IBM Customer Engineering Manual, 60-Cycle SMS Power Supply, Form 225-6478.) The input voltage is regulated by a constant voltage transformer. The output DC voltages are controlled for logic circuits and are merely filtered for other applications.

6.1.01 Ferro Regulator

The ferro-regulator is a closed, shell type transformer which includes a magnetic shunt between the primary and secondary windings (see Figure 6.1-1). Capacitor C1 across one of the secondary windings forms a ferro-resonant circuit. The output voltage is held constant by the use of the shunt in the magnetic path. The shunt path with its associated air gaps allows the rate of flux change (therefore, the developed voltage) to remain substantially constant with variations of the input voltage.

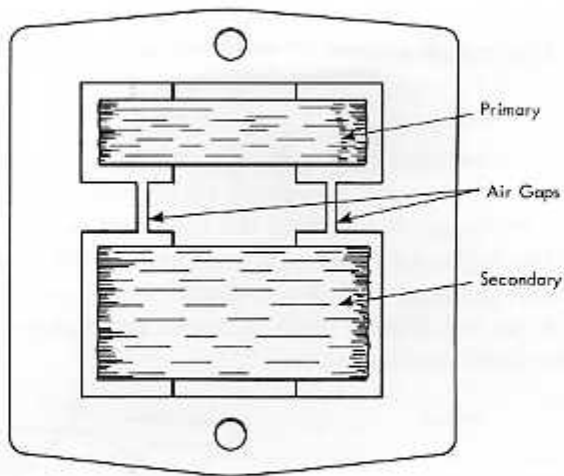

FIGURE 6.1-1. FERRORESONANT REGULATOR TRANSFORMER

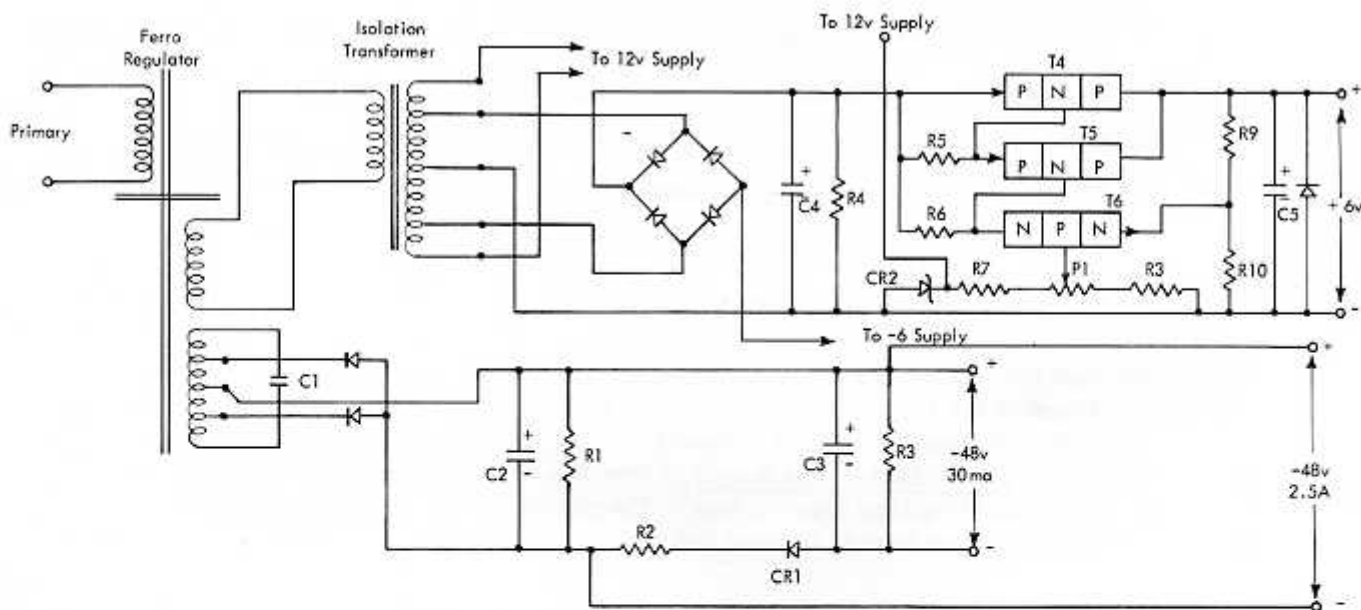

FIGURE 6.1-2. TAPE UNIT POWER SUPPLY

6.1.02 -48 Volt Supply

In -48 volt supply is a full wave, center-tapped rectifier supply. As seen in Figure 6.1-2, there are two output voltages, -48v @2.5 amp and -48v @30 ma. The higher rated output is rectified, then filtered by capacitor C2 and resistor R1. An additional filtering is necessary for the -48 volt used on the BS--neon driver cards. A second stage of filtering is used to further reduce any ripple and CR1 and R2 serve to isolate the 30 ma output from the 2.5 amp output. The diode CR1 prevents the 2.5 amp supply from drawing current from C3 to supply its own needs.

6.1.03 Plus 6 Volt Supply

The output of one of the ferro-regulator secondaries is fed to an isolation transformer that serves to isolate the various outputs from each other. The isolation transformer also allows the rectification of several different voltages and polarities. Rectifiers R1 and R2 (Figure 6.1-2) form a full wave, center-tapped supply. (Rectifiers R3 and R4 are used for the -6 supply but a bridge configuration is used for the rectifier connections for convenience.) This rectified output is filtered by capacitors C4 and C5 and current is maintained by bleeder resistors. Regulation consists of controlling current flow through power transistor X4 in the following manner.

A parallel path for electron flow exists from the negative side of the line-up through the zener diode, CR2, and through the resistor-potentiometer network consisting of R7, P1, and R8. Because there is a constant voltage drop across a zener diode, and therefore across the network, the base of transistor X6 is held at a constant value. Transistor X6 acts as a voltage amplifier to sense a change in output voltage and develop a control signal. Transistor X5 is an emitter follower used as a current amplifier. It takes the control change on its base and develops an adequate current variation to control transistor X4, which is in series with the output power.

If the output voltage should try to increase, due to reduced loading, the following action would occur: there would be a greater voltage drop across R9 and R10. Transistor X6 would become less forward-biased because the base is held constant by CR2 while R10 makes the emitter more positive. Reduced current flow in X6 shows up as a more positive potential on the base of X5 due to the voltage drop across R6. This reduces the forward bias X5 and reduces current through R5. Reduced current through R5 means reduced forward bias for X4 and reduces the output voltage as was desired.

6.1.04 Other Supply Circuits

Other voltages in the supply are developed in a similar manner. There is a 140 volt supply for the clutches, and a 140 volt filtered supply for photo-cell circuits. The latter is similar to the -48 volt supply. A -7.5 volt supply uses a pi-type filter with a choke to handle the heavy current of the prolay drive circuits.

The -6 volt supply operates the same as the +6 volt supply.

The +12 and -12 volt supplies are alike in logic. The zener diode of the +6v supply controls the +12v supply and the zener of the -6v supply gives a standard to the -12v supply also. Remember that there is a voltage drop across the power transistors in

series with the output and, therefore, the supply must be capable of rectifying a voltage higher than the desired output. For example, the +12v supply could supply about 15 volts without the control circuitry.

Each controlled logic voltage (+12v, +6v, -6v, -12v) has a circuit protector in series and there are also AC circuit protectors in series with the 208 volt input to the tape unit.

The AC test equipment outlet is powered separately and is not turned off by the power on/off switch on the tape unit.

IBM

International Business Machines Corporation
Data Processing Division
112 East Post Road, White Plains, New York

Printed in U.S.A. 223-6904