



*Personal Computer
Hardware Reference
Library*

Technical Reference





*Personal Computer
Hardware Reference
Library*

Technical Reference

First Edition (March 1984)

The following paragraph does not apply to the United Kingdom or any country where such provisions are inconsistent with local law: International Business Machines Corporation provides this manual "as is," without warranty of any kind, either expressed or implied, including, but not limited to, the particular purpose. IBM may make improvements and/or changes in the product(s) and/or the program(s) described in this manual at any time.

This product could include technical inaccuracies or typographical errors. Changes are periodically made to the information herein; these changes will be incorporated in new editions of the publication.

It is possible that this material may contain reference to, or information about, IBM products (machines and programs), programming, or services that are not announced in your country. Such references or information must not be construed to mean that IBM intends to announce such IBM products, programming, or services in your country.

Products are not stocked at the address below. Requests for copies of this product and for technical information about the system should be made to your authorized IBM Personal Computer dealer.

The following paragraph applies only to the United States and Puerto Rico: A Reader's Comment Form is provided at the back of this publication. If the form has been removed, address comments to: IBM Corp., Personal Computer, P.O. Box 1328-C, Boca Raton, Florida 33432. IBM may use or distribute any of the information you supply in any way it believes appropriate without incurring any obligations whatever.

All specifications subject to change without notice.

© Copyright International Business Machines Corporation 1984

FEDERAL COMMUNICATIONS COMMISSION RADIO FREQUENCY INTERFERENCE STATEMENT

Warning: The equipment described herein has been certified to comply with the limits for a Class B computing device, pursuant to Subpart J of Part 15 of FCC rules. Only peripherals (computer input/output devices, terminals, printers, etc.) certified to comply with the Class B limits may be attached to the computer. Operation with non-certified peripherals is likely to result in interference to radio and TV reception. If peripherals not offered by IBM are used with the equipment, it is suggested to use shielded, grounded cables with in-line filters if necessary.

CAUTION

The product described herein is equipped with a grounded plug for the user's safety. It is to be used in conjunction with a properly grounded receptacle to avoid electrical shock.

Notes:

Preface

This manual describes the various units of the IBM Personal Computer AT and how they interact. It also has information about the basic input/output system (BIOS) and about programming support.

The information in this publication is for reference, and is intended for hardware and program designers, programmers, engineers, and anyone else who needs to understand the design and operation of the IBM Personal Computer AT.

This manual consists of nine sections, four of which describe the hardware aspects of the IBM Personal Computer AT including signal charts and register information. Section 5 contains information about the usage of BIOS and a system BIOS listing. Section 6 contains instruction sets for the 80286 microprocessor and the 80287 math coprocessor. Section 7 provides information about characters, keystrokes, and colors. Section 8 has general communications information. Section 9 contains information about the compatibility of the IBM Personal Computer AT and the rest of the IBM Personal Computer family.

A glossary of terms and a bibliography of related publications are included.

Prerequisite Publications

Guide to Operations for the IBM Personal Computer AT

Suggested Reading

- *BASIC* for the IBM Personal Computer
- *Disk Operating System (DOS)*
- *Hardware Maintenance and Service* for the IBM Personal Computer AT
- *MACRO Assembler* for the IBM Personal Computer

Contents

SECTION 1. SYSTEM BOARD	1-1
Description	1-3
Memory	1-4
Microprocessor	1-4
System Performance	1-7
System Timers	1-8
System Interrupts	1-10
ROM Subsystem	1-11
RAM Subsystem	1-12
Direct Memory Access (DMA)	1-12
I/O Channel	1-15
Other Circuits	1-30
Speaker	1-30
Jumper	1-30
Type of Display Adapter Switch	1-31
Variable Capacitor	1-31
Keyboard Controller	1-31
Real-time Clock/Complementary Metal Oxide Semiconductor (RT/CMOS) RAM Information	1-45
Specifications	1-55
System Unit	1-55
Connectors	1-57
Logic Diagrams	1-61
SECTION 2. COPROCESSOR	2-1
Description	2-3
Programming Interface	2-3
Hardware Interface	2-4
SECTION 3. POWER SUPPLY	3-1
Inputs	3-3
Outputs	3-3
Output Protection	3-4
Dummy Load	3-4
Output Voltage Sequencing	3-4
No-Load Operation	3-5
Power-Good Signal	3-5

Fan-Out	3-6
Connectors	3-6
SECTION 4. KEYBOARD	4-1
Description	4-3
Interface	4-3
Sequencing Key Code Scanning	4-3
Keyboard Buffer	4-3
Keys	4-3
Functions Performed at Power-On Time	4-4
Power-On Reset	4-4
Basic Assurance Test	4-4
Commands from the System	4-5
Keyboard Outputs	4-10
Key Scan Codes	4-10
Command Codes to the System	4-12
Clock and Data Signals	4-14
Keyboard Data Output	4-15
Keyboard Data Input	4-15
Keyboard Layout	4-16
Specifications	4-23
Keyboard Connector	4-23
SECTION 5. SYSTEM BIOS	5-1
System BIOS	5-3
System BIOS Usage	5-3
Keyboard Encoding and Usage	5-12
Extended Codes	5-17
SECTION 6. INSTRUCTION SET	6-1
Instruction Sets	6-3
80286 Microprocessor Instruction Set	6-3
Data Transfer	6-3
Arithmetic	6-6
Logic	6-10
String Manipulation	6-12
Control Transfer	6-13
Processor Control	6-19
Protection Control	6-21
80287 Coprocessor Instruction Set	6-24
Data Transfer	6-24
Comparison	6-25
Constants	6-26

Arithmetic	6-27
Transcendental	6-29
Processor Control	6-29

SECTION 7. CHARACTERS, KEYSTROKES, AND

COLORS	7-1
Characters, Keystrokes, and Color	7-3

SECTION 8. COMMUNICATIONS **8-1**

Communications	8-3
Establishing a Data Link	8-5

SECTION 9. IBM PERSONAL COMPUTER

COMPATIBILITY	9-1
Hardware Considerations	9-3
System Board	9-3
20Mb Fixed Disk Drive	9-4
High Capacity Diskette Drive	9-4
Adapters	9-4
Keyboard	9-4
The IBM Personal Computer AT Does Not Support	9-5
Application Guidelines	9-5
High-Level Language Considerations	9-5
Assembler Language Programming Considerations	9-6
Multi-tasking Provisions	9-11
SYS REQ Key	9-15
Copy Protection	9-22
Machine-Sensitive Code	9-23

Glossary	Glossary-1
-----------------------	-------------------

Bibliography	Bibliography-1
---------------------------	-----------------------

Index	Index-1
--------------------	----------------

Notes:



INDEX TAB LISTING

Section 1: System Board

Section 2: Coprocessor

Section 3: Power Supply

Section 4: Keyboard

Section 5: System BIOS

Section 6: Instruction Set

SECTION 1

SECTION 2

SECTION 3

SECTION 4

SECTION 5

SECTION 6

Notes:



Section 7: Characters, Keystrokes, and Colors
Section 8: Communications
Section 9: Compatibility
Glossary
Bibliography
Index

Notes:



System Block Diagram

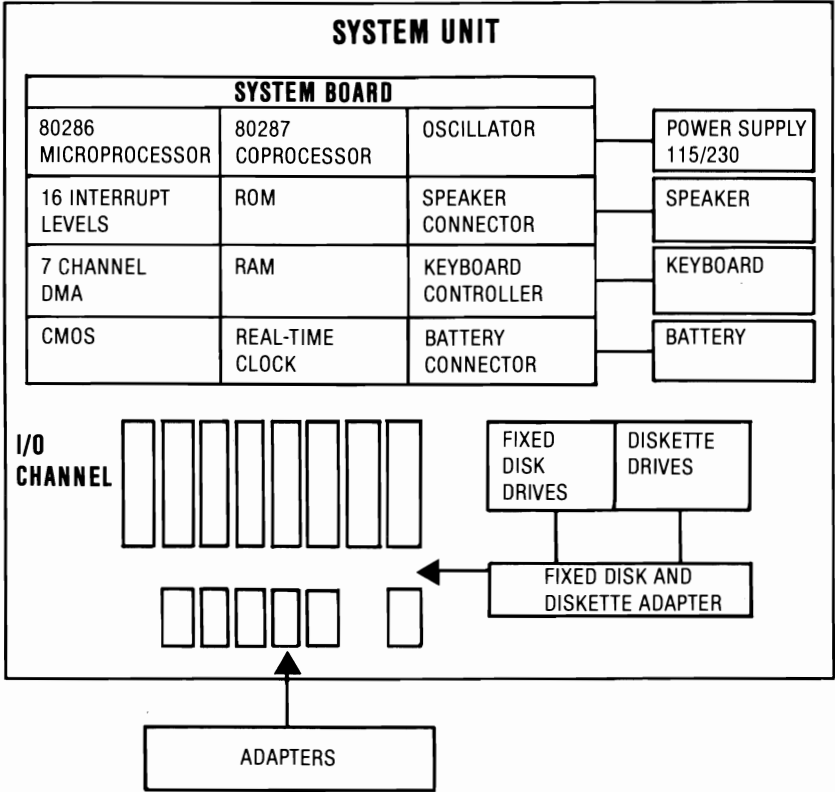

Notes:



SECTION 1. SYSTEM BOARD

Contents

Description	1-3
Memory	1-4
Microprocessor	1-4
Real-Address Mode	1-4
Protected Mode	1-5
System Performance	1-7
System Timers	1-8
System Interrupts	1-10
ROM Subsystem	1-11
RAM Subsystem	1-12
Direct Memory Access (DMA)	1-12
Programming the 16-Bit DMA Channels	1-14
I/O Channel	1-15
I/O Channel Signal Description	1-22
Other Circuits	1-30
Speaker	1-30
Jumper	1-30
Type of Display Adapter Switch	1-31
Variable Capacitor	1-31
Keyboard Controller	1-31
Receiving Data from the Keyboard	1-32
Scan Code Translation	1-32
Sending Data to the Keyboard	1-37
Inhibit	1-37
Keyboard Controller System Interface	1-37

Status Register	1-38
Status-Register Bit Definition	1-38
Output Buffer	1-39
Input Buffer	1-40
Commands (I/O Address hex 64)	1-40
I/O Ports	1-43
Real-time Clock/Complementary Metal Oxide Semiconductor (RT/CMOS) RAM Information	1-45
Real-time Clock Information	1-45
CMOS RAM Configuration Information	1-48
I/O Operations	1-54
Specifications	1-55
System Unit	1-55
Size	1-55
Weight	1-55
Power Cables	1-55
Environment	1-55
Heat Output	1-56
Noise Level	1-56
Electrical	1-56
Connectors	1-57
Logic Diagrams	1-61

Description

The system board is approximately 30.5 by 33 centimeters (12 by 13 inches) and uses very large scale integration (VLSI) technology. It has the following components:

- Intel 80286 Microprocessor
- System support function:
 - 7-Channel Direct Memory Access (DMA)
 - 16-level interrupt
 - System clock
 - Three programmable timers
- 64Kb read-only memory (ROM) subsystem, expandable to 128Kb
- Either a 256Kb or a 512Kb random-access memory (RAM) Subsystem
- Speaker attachment
- Complementary metal oxide semiconductor (CMOS) memory RAM to maintain system configuration
- Real-Time clock
- Battery backup for CMOS configuration table and Real-Time Clock
- Keyboard attachment
- 8 input/output (I/O) slots:
 - 6 with a 36- and a 62-pin card-edge socket.
 - 2 with only the 62-pin card-edge socket.

Memory

The system board has two banks of memory sockets, each supporting 18 128K by 1 modules for a total maximum memory size of 512Kb, with parity checking.

Microprocessor

The Intel 80286 Microprocessor has a 24-bit address, 16-bit memory interface¹, an extensive instruction set, DMA and interrupt support capabilities, a hardware fixed-point multiply and divide, integrated memory management, four-level memory protection, 1-gigabyte (1,073,741,824 bytes) of virtual address space for each task, and two operating modes: the 8086-compatible real-address mode and the protected virtual-address mode. More detailed descriptions of the microprocessor may be found in the publications listed in the Bibliography of this manual.

Real-Address Mode

In the real-address mode, the microprocessor's physical memory is a contiguous array of up to one megabyte. The microprocessor addresses memory by generating 20-bit physical addresses.

The selector portion of the pointer is interpreted as the upper 16 bits of a 20-bit segment address. The lower 4 bits of the 20-bit segment address are always zero. Therefore, segment addresses begin on multiples of 16 bytes.

All segments in the real-address mode are 64Kb in size and may be read, written, or executed. An exception or interrupt can occur if data operands or instructions attempt to wrap around the end of a segment; for example, a word with its low-order byte at offset FFFF and its high-order byte at 0000. If, in the real-address mode, the information contained in the segment does

¹In this manual, the term interface refers to a device that carries signals between functional units.

not use the full 64Kb, the unused end of the segment may be overlaid by another segment to reduce physical memory requirements.

Protected Mode

The protected mode offers extended physical and virtual memory address space, memory protection mechanisms, and new operations to support operating systems and virtual memory.

The protected mode provides a 1-gigabyte virtual address space per task mapped into a 16-megabyte physical address space. The virtual address space may be larger than the physical address space, because any use of an address that does not map to a physical memory location will cause a restartable exception.

As in the real-address mode, the protected mode uses 32-bit pointers, consisting of 16-bit selector and offset components. The selector, however, specifies an index into a memory resident table rather than the upper 16 bits of a real memory address. The 24-bit base address of the desired segment is obtained from the tables in memory. The 16-bit offset is added to the segment base address to form the physical address. The tables are automatically referenced by the microprocessor whenever a segment register is loaded with a selector. All instructions that load a segment register will refer to the memory based-tables without additional program support. The memory-based tables contain 8-byte values called *descriptors*.

Following is a block diagram of the system board.

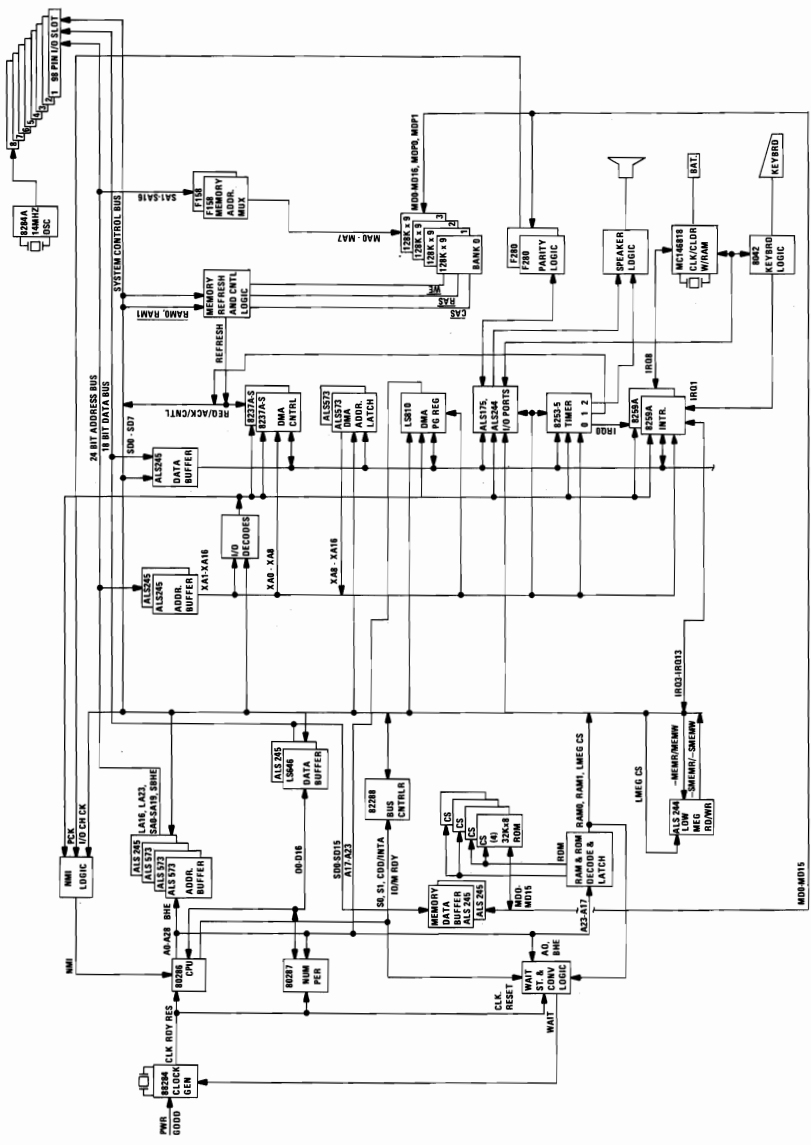

System Board Block Diagram

System Performance

The 80286 Microprocessor operates at 6 MHz, which results in a clock cycle time of 167 nanoseconds.

A bus cycle requires three clock cycles (which includes 1 wait state) so that a 500-nanosecond, 16-bit, microprocessor cycle time is achieved. 8-bit bus operations to 8-bit devices take 6 clock cycles (which include 4 wait states), resulting in a 1000-nanosecond microprocessor cycle. 16-bit bus operations to 8-bit devices take 12 clock cycles (which include 10 I/O wait states) resulting in a 2000 nanosecond microprocessor cycle.

The refresh controller operates at 6 MHz. Each refresh cycle requires 5 clock cycles to refresh all of the system's dynamic memory; 256 refresh cycles are required every 4 milliseconds. The following formula determines the percent of bandwidth used for refresh.

$$\begin{array}{rcl} \text{\% Bandwidth used} & 5 \text{ cycles} \times 256 & 1280 \\ \text{for Refresh} & = \frac{\quad}{4 \text{ ms}/167 \text{ ns}} & = \frac{\quad}{24000} = 5.3\% \end{array}$$

The DMA controller operates at 3 MHz, which results in a clock cycle time of 333 nanoseconds. All DMA data-transfer bus cycles are five clock cycles or 1.66 microseconds. Cycles spent in the transfer of bus control are not included.

DMA channels 0, 1, 2, and 3 are used for 8-bit data transfers, and channels 5, 6, and 7 process 16-bit transfers. Channel 4 is used to cascade channels 0 through 3 to the microprocessor.

The following figure is a system memory map.

Address	Name	Function
000000 to 07FFFF	512Kb system board	System board memory
080000 to 09FFFF	128Kb	I/O channel memory - IBM Personal Computer AT 128KB Memory Expansion Option
0A0000 to 0BFFFF	128Kb video RAM	Reserved for graphics display buffer
0C0000 to 0DFFFF	128Kb I/O expansion ROM	Reserved for ROM on I/O adapters
0E0000 to 0EFFFF	64Kb Reserved on system board	Duplicated code assignment at address FE0000
0F0000 to 0FFFFF	64Kb ROM on the system board	Duplicated code assignment at address FF0000
100000 to FDFFFF	Maximum memory 15Mb	I/O channel memory - IBM Personal Computer AT 512KB Memory Expansion Option
FE0000 to FEFFFF	64Kb Reserved on system board	Duplicated code assignment at address 0E0000
FF0000 to FFFFFF	64Kb ROM on the system board	Duplicated code assignment at address 0F0000

System Memory Map

System Timers

The system has three programmable timer/counters controlled by an Intel 8254-2 timer/counter chip and defined as Channels 0 through 2 as follows:

Channel 0	System Timer
GATE 0	Tied on
CLK IN 0	1.190 MHz OSC
CLK OUT 0	8259A IRQ 0
Channel 1	Refresh Request Generator

- GATE 1** Tied on
- CLK IN 1** 1.190 MHz OSC
- CLK OUT 1** Request Refresh Cycle

Note: Channel 1 is programmed as a rate generator to produce a 15-microsecond period signal.

Channel 2 Tone Generation for Speaker

- GATE 2** Controlled by bit 0 of port hex 61 PPI bit
- CLK IN 2** 1.190 MHz OSC
- CLK OUT 2** Used to drive the speaker

The 8254-2 Timer/Counter is a programmable interval timer/counter that system programs treat as an arrangement of four external I/O ports. Three ports are treated as counters; the fourth is a control register for mode programming. Following is a system-timer block diagram.

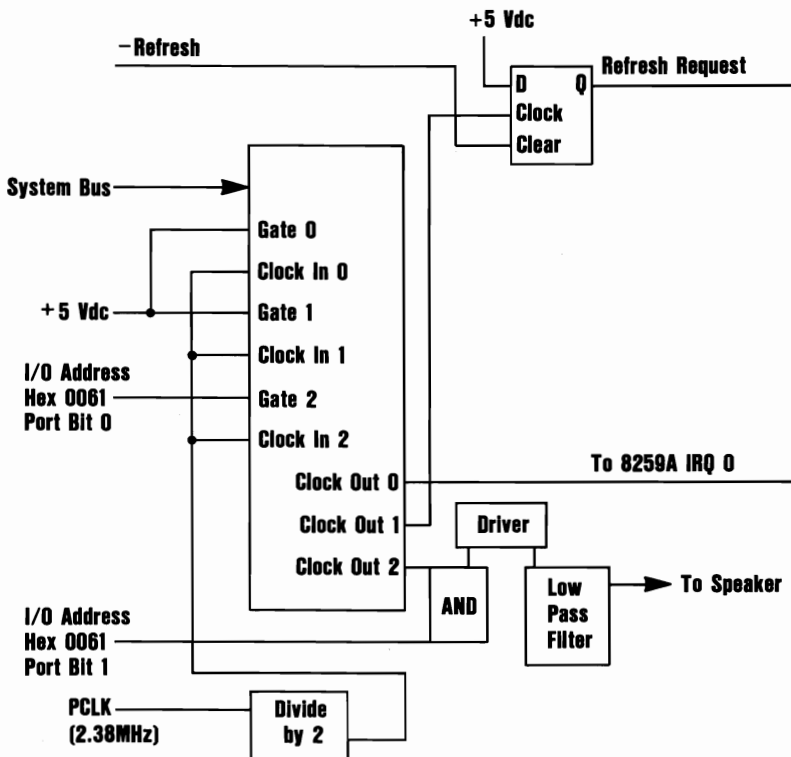

System Interrupts

The 80286 Microprocessor NMI and two 8259A Interrupt Controller chips provide 16 levels of system interrupts. The following shows the interrupt-level assignments in decreasing priority.

Note: Any or all interrupts may be masked (including the microprocessor's NMI).

Level	Function
MicroProcessor NMI	Parity or I/O Channel Check
Interrupt Controllers	
CTLR 1 CTLR 2	
IRQ 0	Timer Output 0
IRQ 1	Keyboard (Output Buffer Full)
IRQ 2	Interrupt from CTLR 2
	Realtime Clock Interrupt
	Software Redirected to INT 0AH (IRQ 2)
	Reserved
	Reserved
	Reserved
	Coprocessor
	Fixed Disk Controller
	Reserved
IRQ 3	Serial Port 2
IRQ 4	Serial Port 1
IRQ 5	Parallel Port 2
IRQ 6	Diskette Controller
IRQ 7	Parallel Port 1

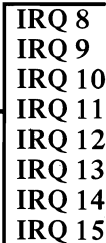

ROM Subsystem

The system board's ROM subsystem consists of two 32K by 8-bit ROM/EPROM modules or four 16K by 8-bit ROM/EPROM modules in a 32K by 16-bit arrangement. The code for odd and even addresses resides in separate modules. ROM is assigned at the top of the first and last 1M address space (hex 0F0000 and hex FF0000). ROM is not parity-checked. Its access time is 150 nanoseconds and its cycle time is 230 nanoseconds.

RAM Subsystem

The system board's RAM subsystem starts at address hex 000000 of the 16M address space. It consists of either 256Kb or 512Kb of 128K by 1-bit RAM modules. Memory access time is 150 nanoseconds and the cycle time is 275 nanoseconds.

Memory-refresh requests one memory cycle every 15 microseconds through the timer/counter (channel 1). The RAM initialization program performs the following functions:

- Initializes channel 1 of the timer/counter to the rate generation mode, with a period of 15 microseconds.
- Performs a memory write operation to any memory location

Note: The memory must be accessed or refreshed eight times before it can be used.

Direct Memory Access (DMA)

The system supports seven DMA channels. Two Intel 8237A-5 DMA Controller Chips are used, with four channels for each chip. The DMA channels are assigned as follows:

Ctrl 1	Ctrl 2
Ch 0 - Spare	Ch 4 - Cascade for Ctrl 1
Ch 1 - SDLC	Ch 5 - Spare
Ch 2 - Diskette (IBM Personal Computer)	Ch 6 - Spare
Ch 3 - Spare	Ch 7 - Spare

DMA Channels

DMA controller 1 contains channels 0 through 3. These channels support 8-bit data transfers between 8-bit I/O adapters and 8- or

16-bit system memory. Each channel can transfer data throughout the 16-megabyte system-address space in 64Kb blocks.

DMA controller 2 contains channels 4 through 7. Channel 4 is used to cascade channels 0 through 3 to the microprocessor. Channels 5, 6, and 7 support 16-bit data transfers between 16-bit I/O adapters and 16-bit system memory. These DMA channels can transfer data throughout the 16-megabyte system-address space in 128Kb blocks. Channels 5, 6, and 7 cannot transfer data on odd byte boundaries.

The following figure shows the addresses for the page register.

Page Register	I/O Hex Address
DMA Channel 0	0087
DMA Channel 1	0083
DMA Channel 2	0081
DMA Channel 3	0082
DMA Channel 5	008B
DMA Channel 6	0089
DMA Channel 7	008A
Refresh	008F

Page Register Addresses

The following figures show address generation for the DMA channels.

Source	DMA Page Registers	8237A-5
Address	A23<----->A16	A15<----->A0

Address Generation for DMA Channels 3 through 0

Note: The addressing signal, 'byte high enable' (BHE), is generated by inverting address line A0.

Source	DMA Page Registers	8237A-5
Address	A23<----->A17	A16<----->A1

Address Generation for DMA Channels 7 through 5

Note: The addressing signals, 'BHE' and 'A0', are forced to a logic 0.

Addresses for all DMA channels do not increase or decrease through page boundaries (64Kb for channels 0 through 3 and 128Kb for channels 5 through 7).

Programming the 16-Bit DMA Channels

DMA channels 5 through 7 perform 16-bit data transfers. Access can be gained only to 16 bit devices (I/O or memory) during the DMA cycles of channels 5 through 7. Access to the DMA controller (8237A-5), which controls these channels, is through I/O addresses 0C0 through 0DF. The command codes for the DMA controller are as follows:

Hex Address	Command Codes
0C0	CH0 base and current address
0C2	CH0 base and current word count
0C4	CH1 base and current address
0C6	CH1 base and current word count
0C8	CH2 base and current address
0CA	CH2 base and current word count
0CC	CH3 base and current address
0CE	CH3 base and current word count
0D0	Read Status Register/Write Command Register
0D2	Write Request Register
0D4	Write Single Mask Register Bit
0D6	Write Mode Register
0D8	Clear Byte Pointer Flip-Flop
0DA	Read Temporary Register/Write Master Clear
0DC	Clear Mask Register
0DE	Write All Mask Register Bits

DMA Controller Registers

All DMA memory transfers made with channels 5 through 7 must occur on even-byte boundaries. When the base address for these channels is programmed, the real address divided by 2 is the data that is written to the base address register. Also, when the base word count for channels 5 through 7 is programmed, the count is the number of 16-bit words to be transferred. Therefore, DMA channels 5 through 7 can transfer 65,536 words or 128Kb maximum for any selected page of memory. These DMA channels divide the 16Mb memory space into 128Kb pages. When the DMA page registers for channels 5 through 7 are

programmed, data bits D7 through D1 should contain the high-order seven address bits (A23 through A17) of the desired memory space. Data bit D0 of the page registers for channels 5 through 7 is not used in the generation of the DMA memory address.

After power-up time, all internal locations, especially the mode registers, should be loaded with some valid value. This should be done even if some channels are unused.

I/O Channel

The I/O channel supports:

- I/O address space hex 100 to hex 3FF
- 24-bit memory addresses (16Mb)
- Selection of data accesses (either 8- or 16-bit)
- Interrupts
- DMA channels
- I/O wait-state generation
- Open-bus structure (allowing multiple microprocessors to share the system's resources, including memory)
- Refresh of system memory from channel microprocessors.

The following figure shows the location and the numbering of the I/O channel connectors. These connectors consist of eight 62-pin and six 36-pin edge connector sockets.

Note: In two positions on the I/O channel, the 36-pin connector is not present. These positions can support only 62-pin I/O bus adapters.

I/O CHANNEL CONNECTORS

REAR PANEL

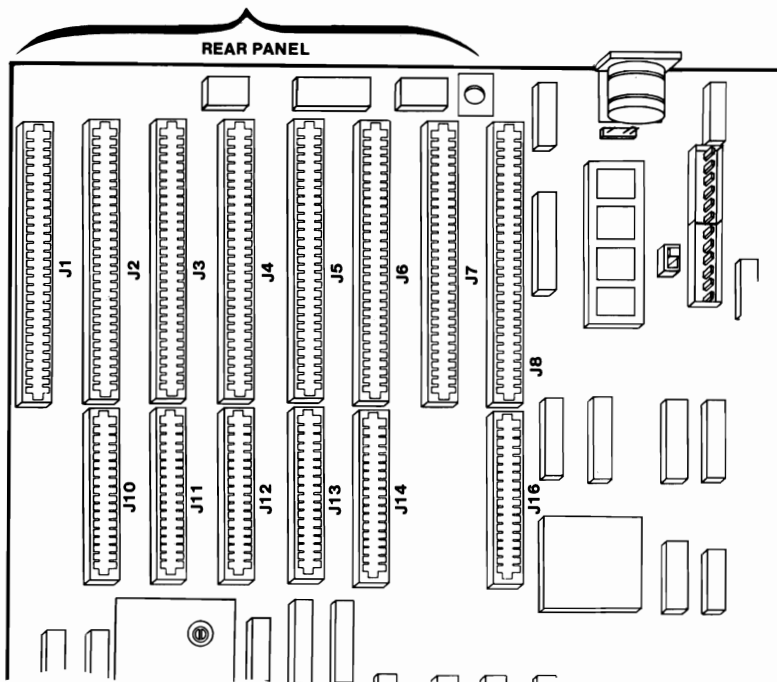

The following figure shows the pin numbering for I/O channel connectors J1 through J8.

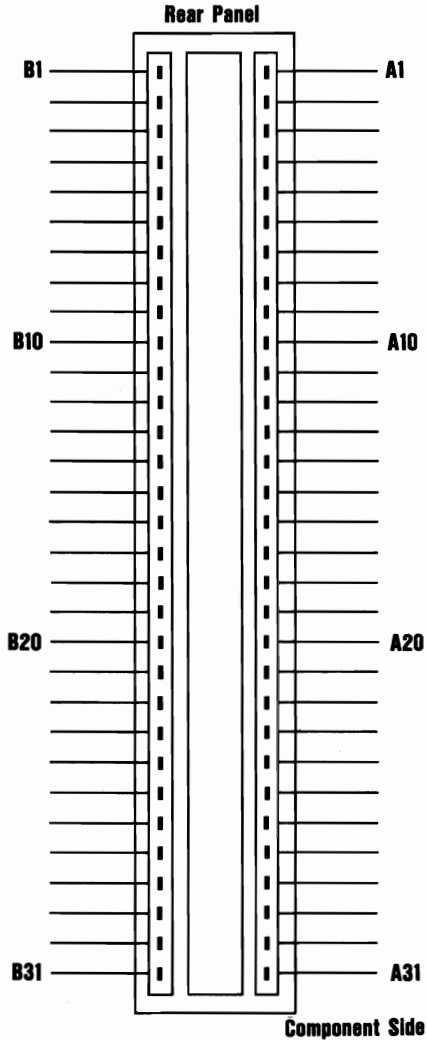

I/O Channel Pin Numbering
(J1-J8)

The following figure shows the pin numbering for I/O channel connectors J12 through J16 and J18.

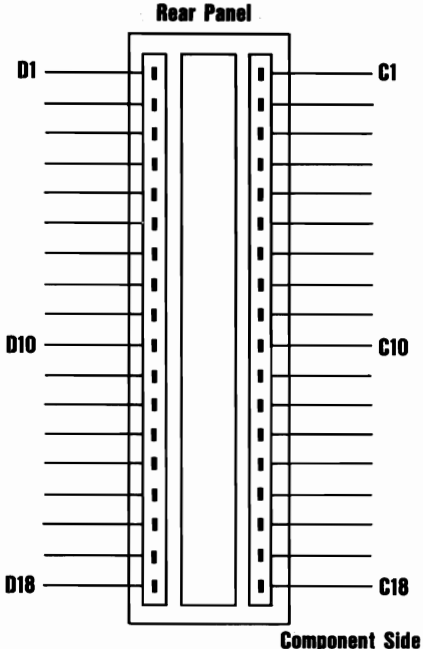

**I/O Channel Pin Numbering
(J10-J14 and J16)**

The following figures summarize pin assignments for the I/O channel connectors.

I/O Pin	Signal Name	I/O
A 1	-I/O CH CK	I
A 2	SD7	I/O
A 3	SD6	I/O
A 4	SD5	I/O
A 5	SD4	I/O
A 6	SD3	I/O
A 7	SD2	I/O
A 8	SD1	I/O
A 9	SD0	I/O
A 10	-I/O CH RDY	I
A 11	AEN	O
A 12	SA19	I/O
A 13	SA18	I/O
A 14	SA17	I/O
A 15	SA16	I/O
A 16	SA15	I/O
A 17	SA14	I/O
A 18	SA13	I/O
A 19	SA12	I/O
A 20	SA11	I/O
A 21	SA10	I/O
A 22	SA9	I/O
A 23	SA8	I/O
A 24	SA7	I/O
A 25	SA6	I/O
A 26	SA5	I/O
A 27	SA4	I/O
A 28	SA3	I/O
A 29	SA2	I/O
A 30	SA1	I/O
A 31	SA0	I/O

I/O Channel (A-Side, J1 through J8)

I/O Pin	Signal Name	I/O
B 1	GND	Ground
B 2	RESET DRV	0
B 3	+5 Vdc	Power
B 4	IRQ 9	I
B 5	-5 Vdc	Power
B 6	DRQ2	I
B 7	-12 Vdc	Power
B 8	OWS	I
B 9	+12 Vdc	Power
B 10	GND	Ground
B 11	-SMEMW	0
B 12	-SMEMR	0
B 13	-IOW	I/O
B 14	-IOR	I/O
B 15	-DACK3	0
B 16	DRQ3	I
B 17	-DACK1	0
B 18	DRQ1	I
B 19	-Refresh	I/O
B 20	CLK	0
B 21	IRQ7	I
B 22	IRQ6	I
B 23	IRQ5	I
B 24	IRQ4	I
B 25	IRQ3	I
B 26	-DACK2	0
B 27	T/C	0
B 28	BALE	0
B 29	+5 Vdc	Power
B 30	OSC	0
B 31	GND	Ground

I/O Channel (B-Side J1, through J8)

I/O Pin	Signal Name	I/O
C 1	SBHE	I/O
C 2	LA23	I/O
C 3	LA22	I/O
C 4	LA21	I/O
C 5	LA20	I/O
C 6	LA19	I/O
C 7	LA18	I/O
C 8	LA17	I/O
C 9	-MEMR	I/O
C 10	-MEMW	I/O
C 11	SD08	I/O
C 12	SD09	I/O
C 13	SD10	I/O
C 14	SD11	I/O
C 15	SD12	I/O
C 16	SD13	I/O
C 17	SD14	I/O
C 18	SD15	I/O

I/O Channel (C-Side J10 through J14 and J16)

I/O Pin	Signal Name	I/O
D 1	-MEM CS16	I
D 2	-I/O CS16	I
D 3	IRQ10	I
D 4	IRQ11	I
D 5	IRQ12	I
D 6	IRQ15	I
D 7	IRQ14	I
D 8	-DACK0	O
D 9	DRQ0	I
D 10	-DACK5	O
D 11	DRQ5	I
D 12	-DACK6	O
D 13	DRQ6	I
D 14	-DACK7	O
D 15	DRQ7	I
D 16	+5 Vdc	Power
D 17	-MASTER	I
D 18	GND	Ground

I/O Channel (D-Side, J10 through J14 and J16)

I/O Channel Signal Description

The following is a description of the system board's I/O channel signals. All signal lines are TTL-compatible. I/O adapters should be designed with a maximum of two low-power Shottky (LS) loads per line.

SA0 through SA19 (I/O)

Address bits 0 through 19 are used to address memory and I/O devices within the system. These 20 address lines, in addition to LA17 through LA23, allow access of up to 16Mb of memory. SA0 through SA19 are gated on the system bus when 'BALE' is high and are latched on the falling edge of 'BALE.' These signals are generated by the microprocessor or DMA Controller. They also may be driven by other microprocessors or DMA controllers that reside on the I/O channel.

LA17 through LA23 (I/O)

These signals (unlatched) are used to address memory and I/O devices within the system. They give the system up to 16Mb of addressability. These signals are valid when 'BALE' is high. LA17 through LA23 are not latched during microprocessor cycles and therefore do not stay valid for the whole cycle. Their purpose is to generate memory decodes for 1 wait-state memory cycles. These decodes should be latched by I/O adapters on the falling edge of 'BALE.' These signals also may be driven by other microprocessors or DMA controllers that reside on the I/O channel.

CLK (0)

This is the 6-MHz system clock. It is a synchronous microprocessor cycle clock with a cycle time of 167 nanoseconds. The clock has a 50% duty cycle. This signal should only be used for synchronization. It is not intended for uses requiring a fixed frequency.

RESET DRV (0)

'Reset drive' is used to reset or initialize system logic at power-up time or during a low line-voltage outage. This signal is active high.

SD0 through SD15 (I/O)

These signals provide bus bits 0 through 15 for the microprocessor, memory, and I/O devices. D0 is the least-significant bit and D15 is the most-significant bit. All 8-bit devices on the I/O channel should use D0 through D7 for communications to the microprocessor. The 16-bit devices will use D0 through D15. To support 8-bit devices, the data on D8 through D15 will be gated to D0 through D7 during 8-bit transfers to these devices; 16-bit microprocessor transfers to 8-bit devices will be converted to two 8-bit transfers.

BALE (0) (buffered)

'Address latch enable' is provided by the 82288 Bus Controller and is used on the system board to latch valid addresses and memory decodes from the microprocessor. It is available to the I/O channel as an indicator of a valid microprocessor or DMA address (when used with 'AEN'). Microprocessor addresses SA0 through SA19 are latched with the falling edge of 'BALE.' 'BALE' is forced high during DMA cycles.

-I/O CH CK (I)

'-I/O channel check' provides the system board with parity (error) information about memory or devices on the I/O channel. When this signal is active, it indicates an uncorrectable system error.

I/O CH RDY (I)

'I/O channel ready' is pulled low (not ready) by a memory or I/O device to lengthen I/O or memory cycles. Any slow device using this line should drive it low immediately upon detecting its valid address and a Read or Write command. Machine cycles are extended by an integral number of clock cycles (167 nanoseconds). This signal should be held low for no more than 2.5 microseconds.

IRQ3-IRQ7, IRQ9-IRQ12 and IRQ 14 through 15 (I)

Interrupt Requests 3 through 7, 9 through 12, and 14 through 15 are used to signal the microprocessor that an I/O device needs attention. The interrupt requests are prioritized, with IRQ9 through IRQ12 and IRQ14 through IRQ15 having the highest priority (IRQ9 is the highest) and IRQ3 through IRQ7 having the lowest priority (IRQ7 is the lowest). An interrupt request is generated when an IRQ line is raised from low to high. The line must be held high until the microprocessor acknowledges the interrupt request (Interrupt Service routine). Interrupt 13 is used on the system board and is not available on the I/O channel. Interrupt 8 is used for the real-time clock.

-IOR (I/O)

'-I/O Read' instructs an I/O device to drive its data onto the data bus. It may be driven by the system microprocessor or DMA controller, or by a microprocessor or DMA controller resident on the I/O channel. This signal is active low.

-IOW (I/O)

'-I/O Write' instructs an I/O device to read the data on the data bus. It may be driven by any microprocessor or DMA controller in the system. This signal is active low.

-SMEMR (O) -MEMR (I/O)

These signals instruct the memory devices to drive data onto the data bus. '-SMEMR' is active only when the memory decode is within the low 1Mb of memory space. '-MEMR' is active on all memory read cycles. '-MEMR' may be driven by any microprocessor or DMA controller in the system. '-SMEMR' is derived from '-MEMR' and the decode of the low 1Mb of memory. When a microprocessor on the I/O channel wishes to drive '-MEMR', it must have the address lines valid on the bus for one system clock period before driving '-MEMR' active. Both signals are active LOW.

-SMEMW (O) -MEMW (I/O)

These signals instruct the memory devices to store the data present on the data bus. '-SMEMW' is active only when the memory decode is within the low 1Mb of the memory space. '-MEMW' is active on all memory read cycles. '-MEMW' may be driven by any microprocessor or DMA controller in the system. '-SMEMW' is derived from '-MEMW' and the decode of the low 1Mb of memory. When a microprocessor on the I/O channel wishes to drive '-MEMW', it must have the address lines valid on the bus for one system clock period before driving '-MEMW' active. Both signals are active low.

DRQ0-DRQ3 and DRQ5-DRQ7 (I)

DMA Requests 0 through 3 and 5 through 7 are asynchronous channel requests used by peripheral devices and the I/O channel microprocessors to gain DMA service (or control of the system). They are prioritized, with 'DRQ0' having the highest priority and 'DRQ7' having the lowest. A request is generated by bringing a DRQ line to an active level. A DRQ line must be held high until the corresponding 'DMA Request Acknowledge' (DACK) line goes active. 'DRQ0' through 'DRQ3' will perform 8-bit DMA transfers; 'DRQ5' through 'DRQ7' will perform 16-bit transfers. 'DRQ4' is used on the system board and is not available on the I/O channel.

-DACK0 to -DACK3 and -DACK5 to -DACK7 (O)

-DMA Acknowledge 0 to 3 and 5 to 7 are used to acknowledge DMA requests (DRQ0 through DRQ7). They are active low.

AEN (O)

'Address Enable' is used to degate the microprocessor and other devices from the I/O channel to allow DMA transfers to take place. When this line is active, the DMA controller has control of the address bus, the data-bus Read command lines (memory and I/O), and the Write command lines (memory and I/O).

-REFRESH (I/O)

This signal is used to indicate a refresh cycle and can be driven by a microprocessor on the I/O channel.

T/C (O)

'Terminal Count' provides a pulse when the terminal count for any DMA channel is reached.

SBHE (I/O)

'Bus High Enable' (system) indicates a transfer of data on the upper byte of the data bus, SD8 through SD15. Sixteen-bit devices use 'SBHE' to condition data bus buffers tied to SD8 through SD15.

-MASTER (I)

This signal is used with a DRQ line to gain control of the system. A processor or DMA controller on the I/O channel may issue a DRQ to a DMA channel in cascade mode and receive a '-DACK'. Upon receiving the '-DACK', an I/O microprocessor may pull '-MASTER' low, which will allow it to

UPDATE NUMBER 4

IBM TECHNICAL REFERENCE UPDATE

Note: All previous Technical Reference updates must be installed before installing this update.

This package contains updates to the IBM Personal Computer AT *Technical Reference* manual.

IBM PERSONAL COMPUTER AT TECHNICAL REFERENCE UPDATE

The following pages update the *Technical Reference* for the IBM Personal Computer AT.

Replace or add the update pages as instructed below.

1-27 and 1-28 Replace

1-28.1 and 1-28.2 Replace

Discard this instruction sheet.



control the system address, data, and control lines (a condition known as *tri-state*). After '-MASTER' is low, the I/O microprocessor must wait one system clock period before driving the address and data lines, and two clock periods before issuing a Read and Write command. If this signal is held low for more than 15 microseconds, system memory may be lost because of a lack of refresh.

-MEM CS16 (I)

'-MEM 16 Chip Select' signals the system board if the present data transfer is a 1 wait-state, 16-bit, memory cycle. It must be derived from the decode of LA17 through LA23. '-MEM CS16' should be driven with an open collector or tri-state driver capable of sinking 20 mA.

-I/O CS16 (I)

'-I/O 16 bit Chip Select' signals the system board that the present data transfer is a 16-bit, 1 wait-state, I/O cycle. It is derived from an address decode. '-I/O CS16' is active low and should be driven with an open collector or tri-state driver capable of sinking 20 mA.

OSC (O)

'Oscillator' (OSC) is a high-speed clock with a 70-nanosecond period (14.31818 MHz). This signal is not synchronous with the system clock. It has a 50% duty cycle.

0WS (I)

The 'Zero Wait State' (0WS) signal tells the microprocessor that it can complete the present bus cycle without inserting any additional wait cycles. In order to run a memory cycle to a 16-bit device without wait cycles, '0WS' is derived from an address decode gated with a Read or Write command. In order to run a memory cycle to an 8-bit device with a minimum of two wait states, '0WS' should be driven active one system clock after the

Read or Write command is active gated with the address decode for the device. Memory Read and Write commands to an 8-bit device are active on the falling edge of the system clock. 'OWS' is active low and should be driven with an open collector or tri-state driver capable of sinking 20 mA.

The following figure is an I/O address map.

Hex Range*	Usage
000-01F	DMA controller 1, 8237A-5
020-03F	Interrupt controller 1, 8259A, Master
02E1	GPIB (Adapter 0)
02E2 & 02E3	Data Acquisition (Adapter 0)
040-05F	Timer 8254.2
060-06F	8042 (Keyboard)
06E2 & 06E3	Data Acquisition (Adapter 1)
070-07F	Real-time clock, NMI (non-maskable interrupt) mask
080-09F	DMA page registers, 74LS612
0A0-0BF	Interrupt controller 2, 8259A
0AE2 & 0AE3	Data Acquisition (Adapter 2)
0C0-0DF	DMA controller 2,8237A-5
0EE2 & 0EE3	Data Acquisition (Adapter 3)
0F0	Clear Math Coprocessor Busy
0F1	Reset Math Coprocessor
0F8-0FF	Math Coprocessor
1F0-1F8	Fixed Disk
200-207	Game I/O
22E1	GPIB (Adapter 1)
278-27F	Parallel printer port 2
2B0-2DF	Alternate Enhanced Graphics Adapter
2F8-27F	Serial port 2
<p>Note: I/O addresses, hex 000 to 0FF, are reserved for the system board I/O. Hex 100 to 3FF are available on the I/O channel. The base addresses for GPIB and Data Acquisition are shown.</p>	

I/O Address Map (Part 1 of 2)

Hex Range*	Usage
300-31F	Prototype card
360-36F	P C Network
378-37F	Parallel printer port 1
380-38F	SDLC, bisynchronous 2
390-393	Cluster
3A0-3AF	Bisynchronous 1
3B0-3BF	Monochrome Display and Printer Adapter
3C0-3CF	Enhanced Graphics Adapter
3D0-3DF	Color/Graphics Monitor Adapter
3F0-3F7	Diskette controller
3F8-3FF	Serial port 1
42E1	GPIB (Adapter 2)
62E1	GPIB (Adapter 3)
790-793	Cluster (Adapter 1)
82E1	GPIB (Adapter 4)
A2E1	GPIB (Adapter 5)
B90-B93	Cluster (Adapter 2)
C2E1	GPIB (Adapter 6)
E2E1	GPIB (Adapter 7)
1390-1393	Cluster (Adapter 3)
2390-2393	Cluster (Adapter 4)

Note: I/O addresses, hex 000 to 0FF, are reserved for the system board I/O. Hex 100 to 3FF are available on the I/O channel. The base addresses for GPIB and Data Acquisition are shown.

I/O Address Map (Part 2 of 2)

At power on time, the non-maskable interrupt (NMI) into the 80286 is masked off. The mask bit can be set and reset with system programs as follows:

Mask On Write to I/O address hex 070, with data bit 7 equal to a logic 0

Mask Off Write to I/O address hex 070, with data bit 7 equal to a logic 1

Note: At the end of POST, the system sets the NMI mask on (NMI enabled).

The following is a description of the Math Coprocessor controls.

0F0 An 8-bit Out command to port F0 will clear the latched Math Coprocessor busy signal. 'Busy' will be latched if the coprocessor asserts its error signal while it is busy. The data output should be zero.

0F1 An 8-bit Out command to port F1 will reset the Math Coprocessor. The data output should be zero.

I/O address hex 080 is used as a diagnostic-checkpoint port or register. This port corresponds to a read/write register in the DMA page register (74LS612).

The '-I/O channel check signal' (-I/O CH CK) is used to report uncorrectable errors on RAM adapters on the I/O channel. This check will create a non-maskable interrupt (NMI) if enabled (see the figure, "I/O Address Map," for enable control). At power-on time, the NMI is masked off and check is disabled. Before check or NMI is enabled, the following steps should be taken.

1. Write data in all I/O RAM-adapter memory locations; this will establish good parity at all locations.
2. Enable I/O channel check.
3. Enable NMI.

Note: All three of these functions are performed by POST.

When a check occurs, an interrupt (NMI) will result. Check the status bits to determine the source of the NMI (see the figure, "I/O Address Map"). To determine the location of the failing adapter, write to any memory location within a given adapter. If the parity check was from that adapter, '-I/O CH CK' will be inactive.

Other Circuits

Speaker

The system unit has a 2-1/4 inch permanent-magnet speaker, which can be driven from:

- The I/O-port output bit
- The timer/counter's clock out
- Both

Jumper

The system board has a 3-pin, Berg-strip connector. The placement of a jumper across the pins of the connector determines whether the system board's 2nd 256Kb of RAM is enabled or disabled. Following are the pin assignments for the connector.

Pin	Assignments
1	No connection
2	Ground
3	A8 (28S42)

RAM Jumper Connector(J18)

The following shows how the jumper affects RAM.

Jumper Positions	Function
1 and 2	Enable 2nd 256Kb of system board ram
2 and 3	Disable 2nd 256Kb of system board ram

RAM Jumper

Note: The normal mode is the enable mode. The disable mode permits the 2nd 256Kb of RAM to reside on adapters plugged into the I/O bus.

Type of Display Adapter Switch

The system board has a slide switch, the purpose of which is to tell the system into which display adapter the primary display is attached. Its positions are assigned as follows:

On (toward the rear of the system unit): The primary display is attached to Color/Graphics Monitor Adapter.

Off (toward the front of the system unit): The primary display is attached to the Monochrome Display and Printer Adapter.

Note: The primary display is activated when the system is turned on.

Variable Capacitor

The system board has a variable capacitor. Its purpose is to adjust the 14.31818 MHz oscillator (OSC) signal that is used to obtain the color burst signal required for color televisions.

Keyboard Controller

The keyboard controller is a single-chip microcomputer (Intel 8042) that is programmed to support the IBM Personal Computer AT Keyboard serial interface. The keyboard controller receives serial data from the keyboard, checks the parity of the data, translates scan codes, and presents the data to the system as a byte of data in its output buffer. The controller will interrupt the system when data is placed in its output buffer. The status register contains bits that indicate if an error was detected while receiving the data. Data may be sent to the keyboard by writing to the keyboard controller's input buffer. The byte of data will be sent to the keyboard serially with an odd parity bit automatically inserted. The keyboard is required to acknowledge all data transmissions. No transmission should be sent to the keyboard until acknowledgment is received for the previous byte sent.

Receiving Data from the Keyboard

The keyboard sends data in a serial format using an 11-bit frame. The first bit is a start bit, and is followed by eight data bits, an odd parity bit, and a stop bit. Data sent is synchronized by a clock supplied by the keyboard. At the end of a transmission, the keyboard controller disables the interface until the system accepts the byte. If the byte of data is received with a parity error, a Resend command is automatically sent to the keyboard. If the keyboard controller is unable to receive the data correctly, a hex FF is placed in its output buffer, and the parity bit in the status register is set to 1, indicating a receive parity error. The keyboard controller will also time a byte of data from the keyboard. If a keyboard transmission does not end within two milliseconds, a hex FF is placed in the keyboard controller's output buffer, and the receive time-out bit in the status register is set. No retries will be attempted on a receive time-out error.

Scan Code Translation

Scan codes, which are received from the keyboard, are converted by the keyboard controller before they are put into the controller's output buffer. The following figure shows the keyboard layout with key numbers.



The following figure is the scan-code translation table.

Keyboard Scan Code	Key	System Scan Code
00		FF
76	90	01
16	2	02
1E	3	03
26	4	04
25	5	05
2E	6	06
36	7	07
3D	8	08
3E	9	09
46	10	0A
45	11	0B
4E	12	0C
55	13	0D
66	15	0E
0D	16	0F
15	17	10
1D	18	11
24	19	12
2D	20	13
2C	21	14
35	22	15
3C	23	16
43	24	17
44	25	18
4D	26	19
54	27	1A
5B	28	1B
5A	43	1C
14	30	1D
1C	31	1E
1B	32	1F
23	33	20
2B	34	21
34	35	22
33	36	23
3B	37	24
42	38	25
4B	39	26
4C	40	27
52	41	28
0E	1	29
12	44	2A
5D	14	2B
1A	46	2C
22	47	2D
21	48	2E
2A	49	2F

(Part 1 of 2). Scan-Code Translation Table

Keyboard Scan Code	Key	System Scan Code
32	50	30
31	51	31
3A	52	32
41	53	33
49	54	34
4A	55	35
59	57	36
7C	106	37
11	58	38
29	61	39
58	64	3A
05	70	3B
06	65	3C
04	71	3D
0C	66	3E
03	72	3F
0B	67	40
02 or 83	73	41
0A	68	42
01	74	43
09	69	44
77	95	45
7E	100	46
6C	91	47
75	96	48
7D	101	49
7B	107	4A
6B	92	4B
73	97	4C
74	102	4D
79	108	4E
69	93	4F
72	98	50
7A	103	51
70	99	52
71	104	53
7F or 84	105	54

(Part 2 of 2)

Scan-Code Translation Table

The following scan codes are reserved.

Keyboard Scan Code	Key	System Scan Code
60	R	55
61	R	56
78	R	57
07	R	58
0F	R	59
17	R	5A
1F	R	5B
27	R	5C
2F	R	5D
37	R	5E
3F	R	5F
47	R	60
4F	R	61
56	R	62
5E	R	63
08	R	64
10	R	65
18	R	66
20	R	67
28	R	68
30	R	69
38	R	6A
40	R	6B
48	R	6C
50	R	6D
57	R	6E
6F	R	6F
13	R	70
19	R	71
39	R	72
51	R	73
53	R	74
5C	R	75
5F	R	76
62	R	77
63	R	78
64	R	79
65	R	7A
67	R	7B
68	R	7C
6A	R	7D
6D	R	7E
6E	R	7F

Scan-Code Translation Table

Sending Data to the Keyboard

Data is sent to the keyboard in the same serial format used to receive data from the keyboard. A parity bit is automatically inserted by the keyboard controller. If the keyboard does not start clocking the data out of the keyboard controller within 15 milliseconds or complete that clocking within 2 milliseconds, a hex FE is placed in the keyboard controller's output buffer, and the transmit time-out error bit is set in the status register. The keyboard is required to respond to all transmissions. If the response contains a parity error, a hex FE is placed in the keyboard controller's output buffer, and the transmit time-out and parity error bits are set in the status register. The keyboard controller is programmed to set a time limit for the keyboard to respond. If 25 milliseconds are exceeded, the keyboard controller places a hex FE in its output buffer and sets the transmit and receive time-out error bits in the status register. No retries will be made by the keyboard controller for any transmission error.

Inhibit

The keyboard interface may be inhibited by a key-controlled hardware switch, although all transmissions to the keyboard will be allowed, regardless of the state of the switch. The keyboard controller tests data received from the keyboard to determine if the byte received is a command response or a scan code. If the byte is a command response, it is placed in the keyboard controller's output buffer. If the byte is a scan code, it is ignored.

Keyboard Controller System Interface

The keyboard controller communicates with the system through a status register, an output buffer, and an input buffer. The following figure is a block diagram of the keyboard interface.

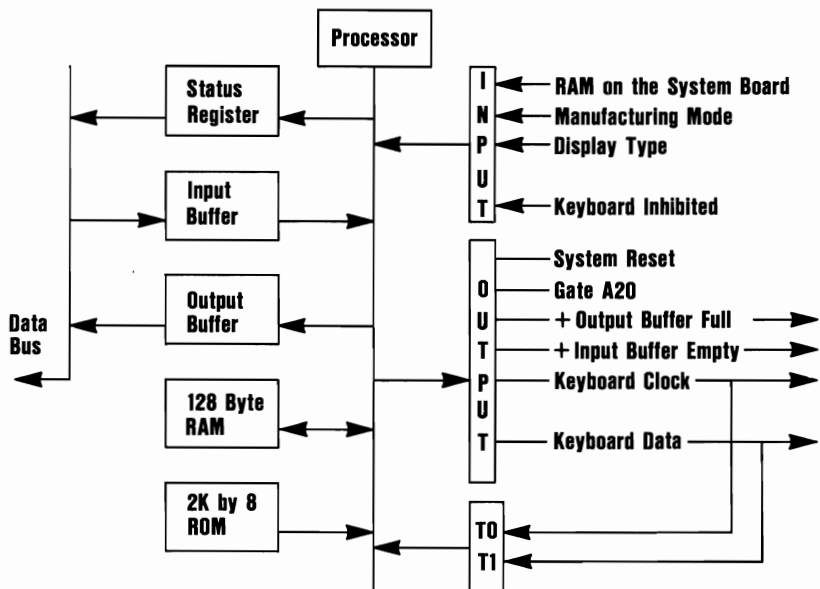

Status Register

The status register is an 8-bit read-only register at I/O address hex 64. It has information about the state of the keyboard controller (8042) and interface. It may be read at any time.

Status-Register Bit Definition

- Bit 0** Output Buffer Full—A 0 indicates that the keyboard controller's output buffer has no data. A 1 indicates that the controller has placed data into its output buffer but the system has not yet read the data. When the system reads the output buffer (I/O address hex 60), this bit will return to a 0.
- Bit 1** Input Buffer Full—A 0 indicates that the keyboard controller's input buffer (I/O address hex 60 or 64) is

empty. A 1 indicates that data has been written into the buffer but the controller has not read the data. When the controller reads the input buffer, this bit will return to 0.

- Bit 2** System Flag—This bit may be set to 0 or 1 by writing to the system's flag bit in the keyboard controller's command byte. It is set to 0 after a power on reset.
- Bit 3** Command/Data—The keyboard controller's input buffer may be addressed as either I/O address hex 60 or 64. Address hex 60 is defined as the data port, and address hex 64 is defined as the command port. Writing to address hex 64 sets this bit to 1; writing to address hex 60 sets this bit to 0. The controller uses this bit to determine if the byte in its input buffer should be interpreted as a command byte or a data byte.
- Bit 4** Inhibit Switch—This bit is updated whenever data is placed in the keyboard controller's output buffer. It reflects the state of the keyboard-inhibit switch. A 0 indicates the keyboard is inhibited.
- Bit 5** Transmit Time-Out—A 1 indicates that a transmission started by the keyboard controller was not properly completed. If the transmit byte was not clocked out within the specified time limit, this will be the only error. If the transmit byte was clocked out but a response was not received within the programmed time limit, the transmit time-out and receive time-out error bits are set On. If the transmit byte was clocked out but the response was received with a parity error, the transmit time-out and parity error bits are set On.
- Bit 6** Receive Time-Out—A 1 indicates that a transmission was started by the keyboard but did not finish within the programmed receive time-out delay.
- Bit 7** Parity Error—A 0 indicates the last byte of data received from the keyboard had odd parity. A 1 indicates the last byte had even parity. The keyboard should send with odd parity.

Output Buffer

The output buffer is an 8-bit read-only register at I/O address hex 60. The keyboard controller uses the output buffer to send scan codes received from the keyboard, and data bytes requested by command to the system. The output buffer should be read only when the output buffer's full bit in the status register is 1.

Input Buffer

The input buffer is an 8-bit write-only register at I/O address hex 60 or 64. Writing to address hex 60 sets a flag, that indicates a data write; writing to address hex 64 sets a flag, indicating a command write. Data written to I/O address hex 60 is sent to the keyboard, unless the keyboard controller is expecting a data byte following a controller command. Data should be written to the controller's input buffer only if the input buffer's full bit in the status register is equal to 0. The following are valid keyboard controller commands.

Commands (I/O Address hex 64)

- 20** Read Keyboard Controller's Command Byte—The controller sends its current command byte to its output buffer.
- 60** Write Keyboard Controller's Command Byte—The next byte of data written to I/O address hex 60 is placed in the controller's command byte. Bit definitions of the command byte are as follows:
- Bit 7** Reserved—Should be written to a 0.
 - Bit 6** IBM Personal Computer Compatibility Mode—Writing a 1 to this bit causes the controller to convert the scan codes received from the keyboard to those used by the IBM

Personal Computer. This includes converting a two-byte break sequence to the one-byte IBM Personal Computer format.

- Bit 5** IBM Personal Computer Mode—Writing a 1 to this bit programs the keyboard to support the IBM Personal Computer keyboard interface. In this mode the controller does not check parity or convert scan codes.
- Bit 4** Disable Keyboard—Writing a 1 to this bit disables the keyboard interface by driving the 'clock' line low. Data is not sent or received.
- Bit 3** Inhibit Override—Writing a 1 to this bit disables the keyboard inhibit function.
- Bit 2** System Flag—The value written to this bit is placed in the system flag bit of the controller's status register.
- Bit 1** Reserved—Should be written to a 0.
- Bit 0** Enable Output-Buffer-Full Interrupt—Writing a 1 to this bit causes the controller to generate an interrupt when it places data into its output buffer.
- AA** Self-Test—This commands the controller to perform internal diagnostic tests. A hex 55 is placed in the output buffer if no errors are detected.
- AB** Interface Test—This commands the controller to test the keyboard clock and data lines. The test result is placed in the output buffer as follows:
- 00** No error detected.
 - 01** The 'keyboard clock' line is stuck low.
 - 02** The 'keyboard clock' line is stuck high.
 - 03** The 'keyboard data' line is stuck low.

04 The 'keyboard data' line is stuck high.

AC Diagnostic Dump—Sends 16 bytes of the controller's RAM, the current state of the input port, the current state of the output port, and the controller's program status word to the system. All items are sent in scan-code format.

AD Disable Keyboard Feature—This command sets bit 4 of the controller's command byte. This disables the keyboard interface by driving the clock line low. Data will not be sent or received.

AE Enable Keyboard Interface—This command clears bit 4 of the command byte, which releases the keyboard interface.

C0 Read Input Port—This commands the controller to read its input port and place the data in its output buffer. This command should be used only if the output buffer is empty.

D0 Read Output Port—This command causes the controller to read its output port and place the data in its output buffer. This command should be issued only if the output buffer is empty.

D1 Write Output Port—The next byte of data written to I/O address hex 60 is placed in the controller's output port.

Note: Bit 0 of the controller's output port is connected to System Reset. This bit should not be written low.

E0 Read Test Inputs—This command causes the controller to read its T0 and T1 inputs. This data is placed in the output buffer. Data bit 0 represents T0, and data bit 1 represents T1.

F0–FF Pulse Output Port—Bits 0 through 3 of the controller's output port may be pulsed low for approximately 6 microseconds. Bits 0 through 3 of this command indicate

which bits are to be pulsed. A 0 indicates that the bit should be pulsed, and a 1 indicates the bit should not be modified.

Note: Bit 0 of the controller's output port is connected to System Reset. Pulsing this bit resets the microprocessor.

I/O Ports

The keyboard controller has two 8-bit I/O ports and two test inputs. One of the ports is assigned for input and the other for output. The controller uses the test inputs to read the state of the keyboard's 'clock' line and the keyboard's 'data' line.

The following figures show bit definitions for the input, output, and test-input ports.

Bit 0	Undefined
Bit 1	Undefined
Bit 2	Undefined
Bit 3	Undefined
Bit 4	RAM on the system board 0 = Disable 2nd 256Kb of system board RAM 1 = Enable 2nd 256Kb of system board RAM
Bit 5	Manufacturing jumper 0 = Manufacturing jumper installed 1 = Jumper not installed
Bit 6	Display type switch 0 = Primary display attached to Color/Graphics adapter 1 = Primary display attached to Monochrome adapter
Bit 7	Keyboard inhibit switch 0 = Keyboard inhibited 1 = Keyboard not inhibited

Input-Port Definitions

Bit 0	System reset
Bit 1	Gate A20
Bit 2	Undefined
Bit 3	Undefined
Bit 4	Output buffer full
Bit 5	Input buffer empty
Bit 6	Keyboard clock (output)
Bit 7	Keyboard data (output)

Output-Port Bit Definitions

T0	Keyboard clock (input)
T1	Keyboard data (input)

Test-Input Port Bit Definitions

Real-time Clock/Complementary Metal Oxide Semiconductor (RT/CMOS) RAM Information

The RT/CMOS RAM chip (Motorola MC146818) contains the real-time clock and 64 bytes of CMOS RAM. The internal clock circuitry uses 14 bytes of this RAM, and the rest is allocated to configuration information. The following figure shows the CMOS RAM addresses.

Addresses	Description
00-0D	* Real-time clock information
0E	* Diagnostic status byte
0F	* Shutdown status byte
10	Diskette drive type byte - drives A and B
11	Reserved
12	Fixed disk type byte - drives C and D
13	Reserved
14	Equipment byte
15	Low base memory byte
16	High base memory byte
17	Low expansion memory byte
18	High expansion memory byte
19-2D	Reserved
2E-2F	2-byte CMOS checksum
30	* Low expansion memory byte
31	* High expansion memory byte
32	* Date century byte
33	* Information flags (set during power on)
34-3F	Reserved

CMOS RAM Address Map

* These bytes are not included in the checksum calculation and are not part of the configuration record.

Real-time Clock Information

The following figure describes real-time clock bytes and specifies their addresses.

Byte	Function	Address
0	Seconds	00
1	Second alarm	01
2	Minutes	02
3	Minute alarm	03
4	Hours	04
5	Hour alarm	05
6	Day of week	06
7	Date of month	07
8	Month	08
9	Year	09
10	Status Register A	0A
11	Status Register B	0B
12	Status Register C	0C
13	Status Register D	0D

Real-Time Clock Information (addresses 00–0D)

Note: The setup program initializes registers A, B, C, and D when the time and date are set. Also Interrupt 1A is the BIOS' interface to read/set the time and date. It initializes the status bytes the same as the Setup program.

Status Register A

- Bit 7** Update in Progress (UIP)—A 1 indicates the time update cycle is in progress. A 0 indicates the current date and time is available to read.
- Bit 6–Bit 4** 22-Stage Divider (DV2 through DV0)—These three divider-selection bits identify which time-base frequency is being used. The system initializes the stage divider to 010, which selects a 32.768kHz time base.
- Bit 3–Bit 0** Rate Selection Bits (RS3 through RS0)—These bits allow the selection of a divider output frequency. The system initializes the rate selection bits to 0110, which selects a 1.024kHz square wave output frequency and a 976.562 microsecond periodic interrupt rate.

Status Register B

- Bit 7** Set—A 0 updates the cycle normally by advancing the counts at one-per-second. A 1 aborts any update cycle in progress and the program can initialize the 14 time-bytes without any further updates occurring until a 0 is written to this bit.
- Bit 6** Periodic Interrupt Enable (PIE)—This bit is a read/write bit that allows an interrupt to occur at a rate specified by the rate and divider bits in register A. A 1 enables an interrupt, and a 0 disables it. The system initializes this bit to 0.
- Bit 5** Alarm Interrupt Enable (AIE)—A 1 enables the alarm interrupt, and a 0 disables it. The system initializes this bit to 0.
- Bit 4** Update-Ended Interrupt Enabled (UIE)—A 1 enables the update-ended interrupt, and a 0 disables it. The system initializes this bit to 0.
- Bit 3** Square Wave Enabled (SQWE)—A 1 enables the the square-wave frequency as set by the rate selection bits in register A, and a 0 disables the square wave. The system initializes this bit to 0.
- Bit 2** Date Mode (DM)—This bit indicates whether the time and date calendar updates are to use binary or binary coded decimal (BCD) formats. A 1 indicates binary, and a 0 indicates BCD. The system initializes this bit to 0.
- Bit 1** 24/12—This bit establishes whether the hours byte is in the 24-hour or 12-hour mode. A 1 indicates the 24-hour, mode and a 0 indicates the 12-hour mode. The system initializes this bit to 1.

Bit 0 Daylight Savings Enabled (DSE)—A 1 enables daylight savings and a 0 disables daylight savings (standard time). The system initializes this bit to 0.

Register C

Bit 7–Bit 4 IRQF, PF, AF, UF—These flag bits are read only and are affected when the 'AIE', 'PIE', and 'UIE' interrupts are enabled in register B.

Bit 3–Bit 0 Reserved

Register D

Bit 7 Valid RAM Bit (VRB)—This bit is read only and indicates the condition of the contents of the CMOS RAM through the power sense pin. A low state of the power sense pin indicates that the real-time clock has lost its power (battery dead). A 1 on the VRB indicates power on the real-time clock and a 0 indicates that the real-time clock has lost power.

Bits 6–Bit 0 Reserved

CMOS RAM Configuration Information

The following lists show bit definitions for the CMOS configuration bytes (addresses hex 0E– 3F).

Diagnostic Status Byte (Hex 0E)

Bit 7 Real-time clock chip has lost power. A 0 indicates that the chip has not lost power, and a 1 indicates that the chip lost power.

- Bit 6** Configuration Record—Checksum Status Indicator—A 0 indicates that checksum is good, and a 1 indicates it is bad.
- Bit 5** Incorrect Configuration Information—This is a check, at power on time, of the equipment byte of the configuration record. A 0 indicates that the configuration information is valid, and a 1 indicates it is invalid. Power-on checks require:
- At least one diskette drive to be installed (bit 0 of the equipment byte set to 1).
 - The primary display adapter setting in configuration matches the system board's display switch setting and the actual display hardware in the system.
- Bit 4** Memory Size Mismatch—A 0 indicates that the power-on check determined the same memory size as in the configuration record and a 1 indicates the memory size is different.
- Bit 3** Fixed Disk Adapter/Drive C Initialization Status—A 0 indicates that the adapter and drive are functioning properly and the system can attempt "boot up." A 1 indicates that the adapter and/or drive C failed initialization, which prevents the system from attempting to "boot up."
- Bit 2** Time Status Indicator—(POST validity check) A 0 indicates that the time is valid and a 1 indicates that the time is invalid.
- Bit 1–Bit 0** Reserved

Shutdown Status Byte (Hex 0F)

The bits in this byte are defined by the power on diagnostics. For more information about this byte, see "BIOS Listing."

Diskette Drive Type Byte (Hex 10)

Bit 7–Bit 4 Type of first diskette drive installed:

- 0000** No drive is present.
- 0001** Double Sided Diskette Drive (48 TPI)
- 0010** High Capacity Diskette Drive (96 TPI)

Note: 0011 through 1111 are reserved.

Bit 3–Bit 0 Type of second diskette drive installed:

- 0000** No drive is present.
- 0001** Double Sided Diskette Drive (48 TPI)
- 0010** High Capacity Diskette Drive (96 TPI)

Note: 0011 through 1111 are reserved.

Hex address 11 contains a reserved byte.

Fixed Disk Type Byte (Hex 12)

Bit 7–Bit 4 Defines the type of first fixed disk drive installed (drive C):

- 0000** No fixed disk drive is present.
- 0001 through 1111 define type 1 through type 15 (see BIOS listing at label FD__TBL).

Bit 3–Bit 0 Defines the type of second fixed disk drive installed (drive D):

- 0000** No fixed disk drive is present.

0001 through 1111 define type 1 through type 15 (see BIOS listing at label FD__TBL).

The following figure shows the BIOS fixed disk parameters.

Type	Cylinders	Heads	Write Pre-comp	Landing Zone
1	306	4	128	305
2	615	4	300	615
3	615	6	300	615
4	940	8	512	940
5	940	6	512	940
6	615	4	no	615
7	462	8	256	511
8	733	5	no	733
9	900	15	no8	901
10	820	3	no	820
11	855	5	no	855
12	855	7	no	855
13	306	8	128	319
14	733	7	no	733
15	Reserved--set to zeros			

BIOS Fixed Disk Parameters

Hex address 13 contains a reserved byte.

Equipment Byte (Hex 14)

Bit 7–Bit 6 Indicates the number of diskette drives installed:

- 00** 1 drive
- 01** 2 drives
- 10** Reserved
- 11** Reserved

Bit 5–Bit 4 Primary display

- 00** Reserved

- 01** Primary display is attached to the Color/Graphics Monitor Adapter in the 40-column mode.
- 10** Primary display is attached to the Color/Graphics Monitor Adapter in the 80-column mode.
- 11** Primary display is attached to the Monochrome Display and Printer Adapter.

Bit 3–Bit 2 Not used.

Bit 1 Math Coprocessor presence bit:

0 Math Coprocessor not installed.

1 Math Coprocessor installed.

Bit 0 The set condition of this bit indicates that diskette drives are installed.

Note: The equipment byte defines basic equipment in the system for power-on diagnostics.

Low and High Base Memory Bytes (Hex 15 and 16)

Bit 7–Bit 0 Address hex 15—Low-byte base size

Bit 7–Bit 0 Address hex 16—High-byte base size

Valid Sizes:

0100H 256Kb system-board RAM

0200H 512Kb system-board RAM

0280H 640Kb 512Kb system board RAM and the IBM Personal Computer AT 128KB Memory Expansion Option

Low and High Memory Expansion Bytes (Hex 17 and 18)

Bit 7–Bit 0 Address hex 17—Low-byte expansion size

Bit 7–Bit 0 Address hex 18—High-byte expansion size

Valid Sizes:

0200H 512Kb I/O adapter

0400H 1024Kb I/O adapter (2 adapters)

600H 1536Kb I/O adapter (3 adapters)

to

3C00H 15360Kb I/O adapter (15Mb maximum)

Hex addresses 19 through 2D are reserved.

Checksum (Hex 2E and 2F)

Address hex 2E High byte of checksum

Address hex 2F Low byte of checksum

Note: Checksum is on addresses hex 10-20.

Low and High Expansion Memory Bytes (Hex 30 and 31)

Bit 7–Bit 0 Address hex 30—Low-byte expansion size

Bit 7–Bit 0 Address hex 31—High-byte expansion size

Valid Sizes:

0200H 512Kb I/O adapter

0400H 1024Kb I/O adapter

0600H 1536Kb I/O adapter

to

3C00H 15360Kb I/O adapter (15Mb maximum)

Note: This word reflects the total expansion memory above the 1Mb address space as determined at power-on time. This expansion memory size can be determined through system interrupt 15 (see the BIOS listing). The base memory at power-on time is determined through the system memory-size-determine interrupt.

Date Century Byte (Hex 32)

Bit 7–Bit 0 BCD value for the century (BIOS interface to read and set).

Information Flag (Hex 33)

Bit 7 Set if the IBM Personal Computer AT 128KB Memory Expansion Option is installed.

Bit 6 This bit is used by the Setup utility to put out a first user message after initial setup.

Bit 5–Bit 0 Reserved

Note: Hex addresses 34 through 3F are reserved.

I/O Operations

Writing to CMOS RAM involves two steps:

1. OUT to port hex 70 with the CMOS address that will be written to.
2. OUT to port hex 71 with the data to be written.

Reading CMOS RAM also requires two steps:

1. OUT to port hex 70 with the CMOS address that is to be read from.
2. IN from port hex 71, and the data read is returned in the AL register.

Specifications

System Unit

Size

- Length: 540 millimeters (21.3 inches)
- Depth: 439 millimeters (17.3 inches)
- Height: 162 millimeters (6.8 inches)

Weight

- 19.05 kilograms (42 pounds)

Power Cables

- Length: 1.8 meters (6 feet)

Environment

- Air Temperature
 - System On: 15.6 to 32.2 degrees C (60 to 90 degrees F)
 - System Off: 10 to 43 degrees C (50 to 110 degrees F)
- Humidity
 - System On: 8% to 80%
 - System Off: 20% to 80%
- Altitude
 - Maximum altitude: 2133.6 meters (7000 feet)

Heat Output

- 1229 British Thermal Units per hour

Noise Level

- Meets Class 3; 42 decibels average-noise rating

Electrical

- VA — 450
- Range 1
 - Nominal - 115 Vac
 - Minimum - 100 Vac

- Maximum - 125 Vac
- Range 2
 - Nominal - 230 Vac
 - Minimum - 200 Vac
 - Maximum - 240 Vac

Connectors

The system board has the following connectors:

- Speaker connector (J19)
- Two power-supply connectors (PS8 and PS9)
- Keyboard connector (J9)
- Power LED and keylock connector (J20)
- Battery connector (J21)

The speaker connector is a 4-pin, keyed, Berg strip. The pin assignments follow.

Pin	Function
1	Data out
2	Key
3	Ground
4	+5 Vdc

Speaker Connector (J19)

The pin assignments for power-supply connectors, P8 and P9, are as follows:

Pin	Assignments	Connector
1	Power good	PS8
2	+5 Vdc	
3	+12 Vdc	
4	-12 Vdc	
5	Ground	
6	Ground	
1	Ground	PS9
2	Ground	
3	-5 Vdc	
4	+5 Vdc	
5	+5 Vdc	
6	+5 Vdc	

Power Supply Connectors

The keyboard connector is a 5-pin, 90-degree Printed Circuit Board (PCB) mounting, DIN connector. The pin assignments are as follows:

Pin	Assignments
1	Keyboard clock
2	Keyboard data
3	Spare
4	Ground
5	+5 Vdc

Keyboard Connector (J22)

The power LED and keylock connector is a 5-pin Berg strip. Its pin assignments follow:

Pin	Assignments
1	LED Power
2	Key
3	Ground
4	Keyboard inhibit
5	Ground

Power LED and Keylock Connector (J20)

The battery connector is a 4-pin, keyed, Berg strip. The pin assignments follow:

Pin	Assignments
1	Ground
2	Not Used
3	Not Used
4	6 Vdc.

Battery Connector (J21)

The following figure shows the layout of the system board.

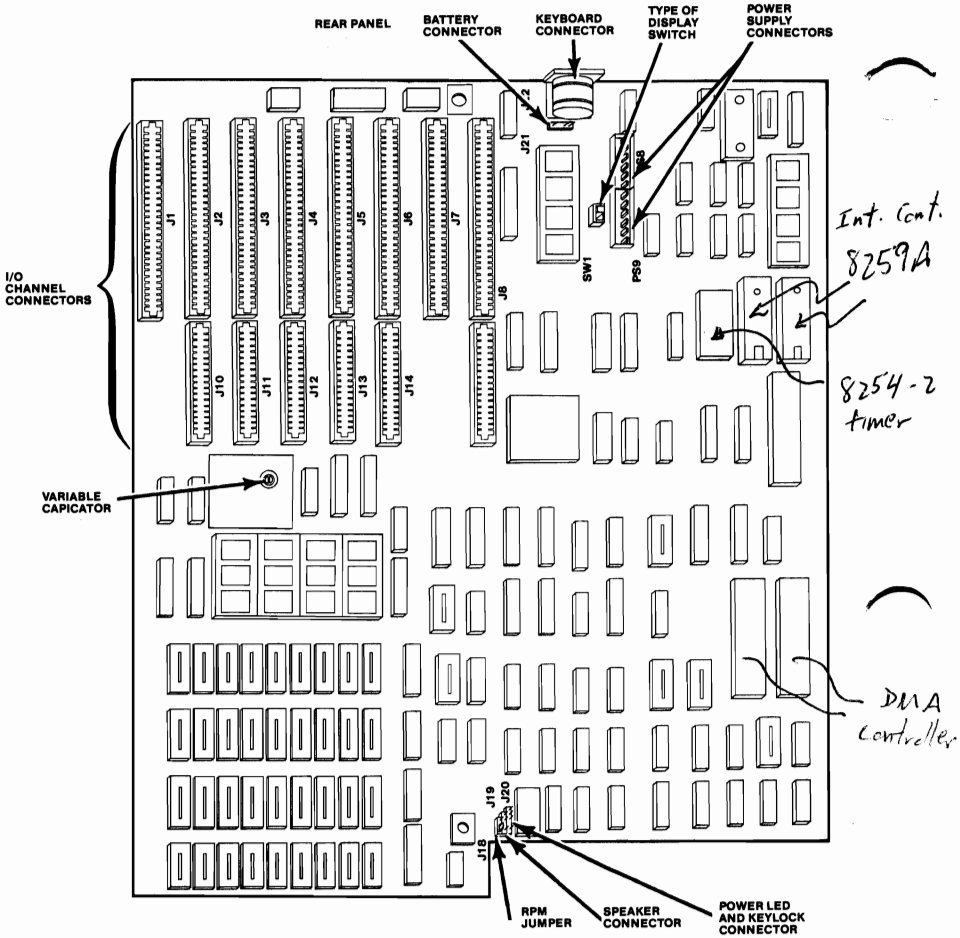

System Board Layout

Logic Diagrams

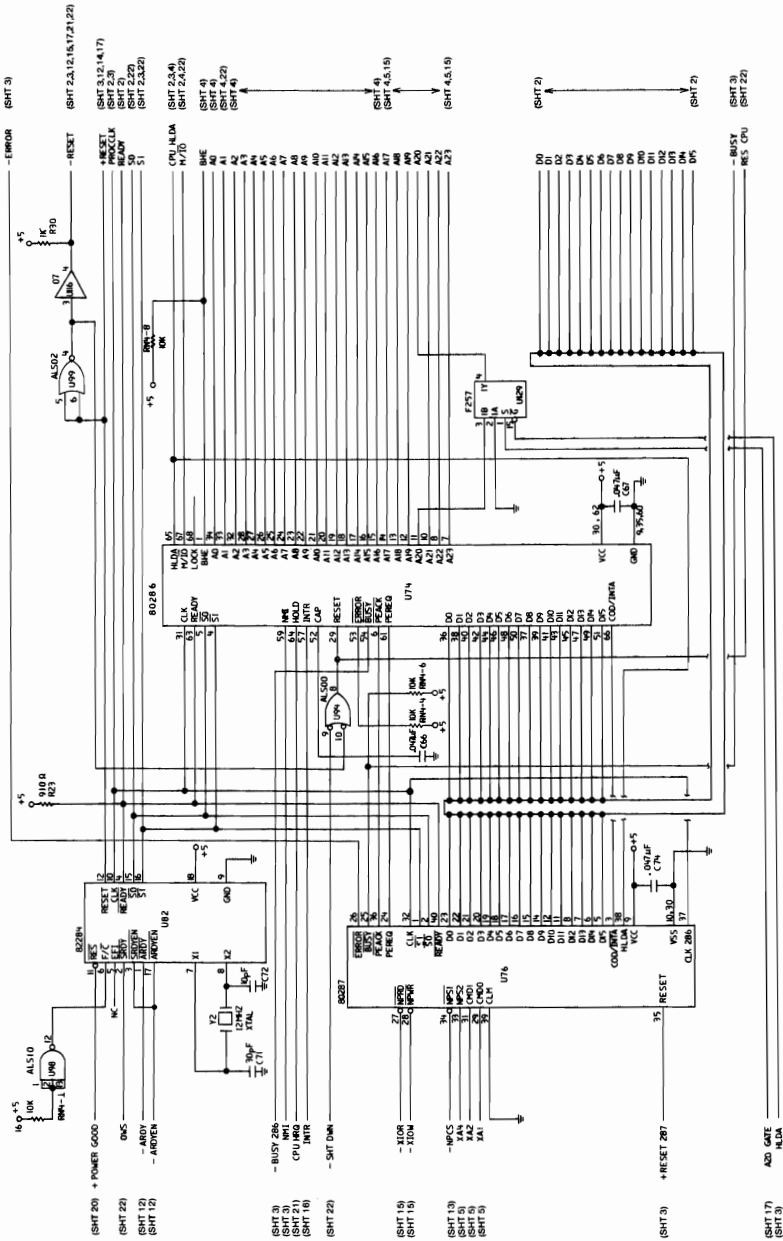

System Board (Sheet 1 of 22)

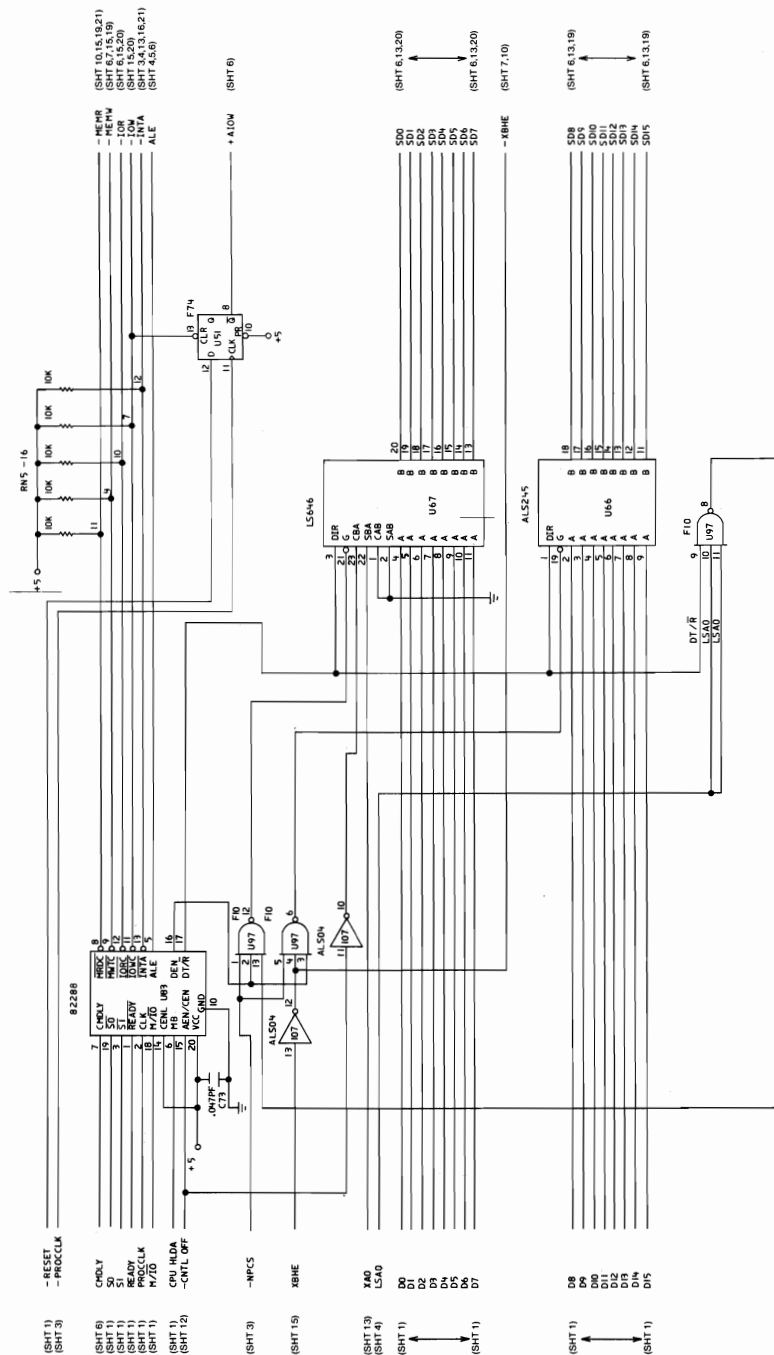

System Board (Sheet 2 of 22)

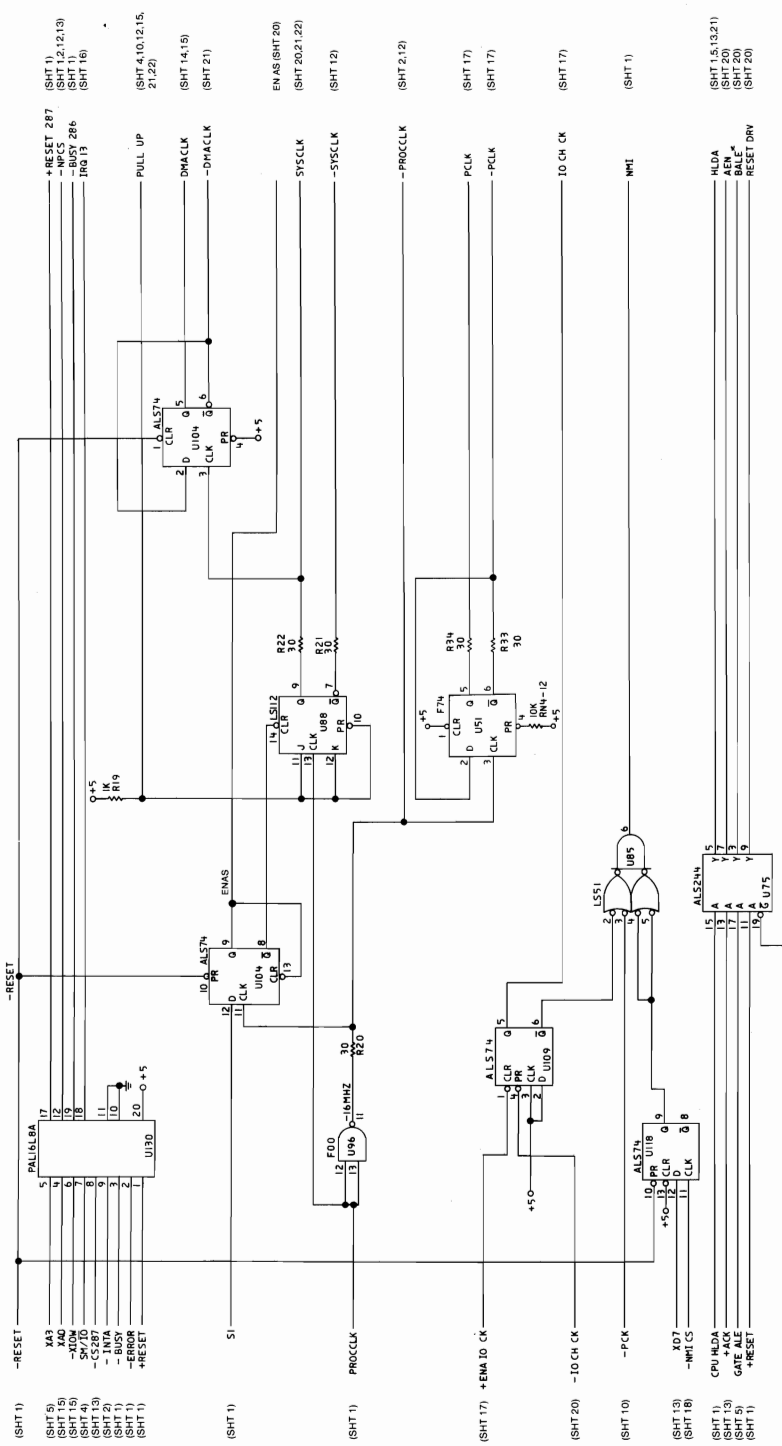

System Board (Sheet 3 of 22)

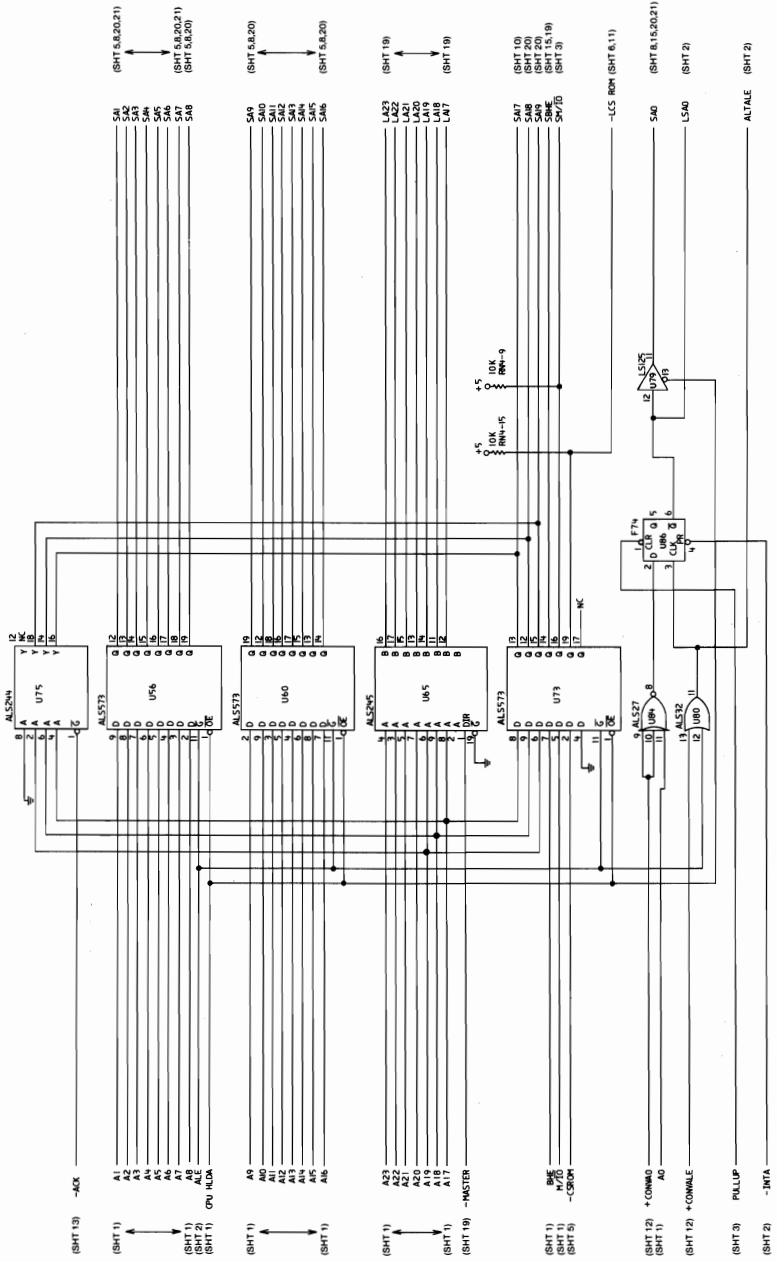

System Board (Sheet 4 of 22)

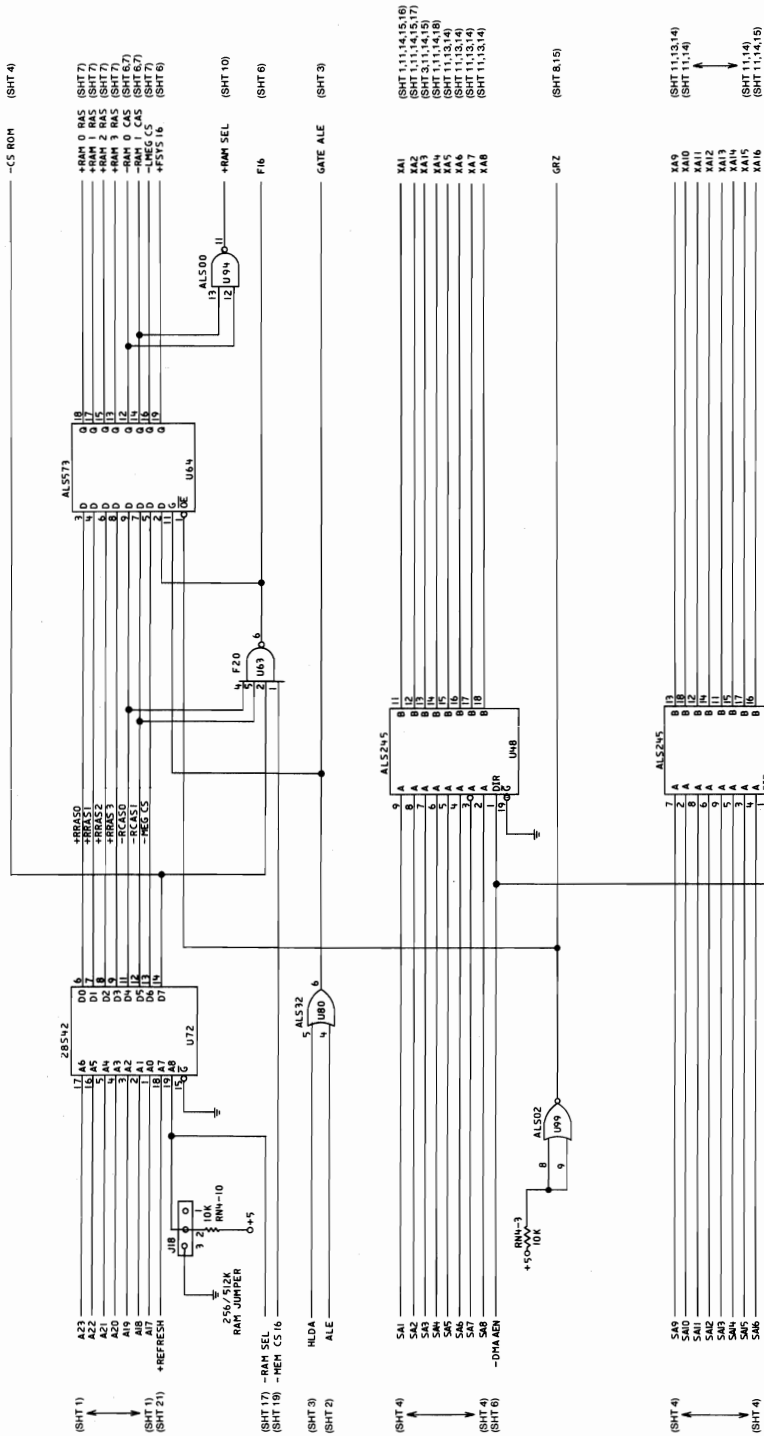

System Board (Sheet 5 of 22)

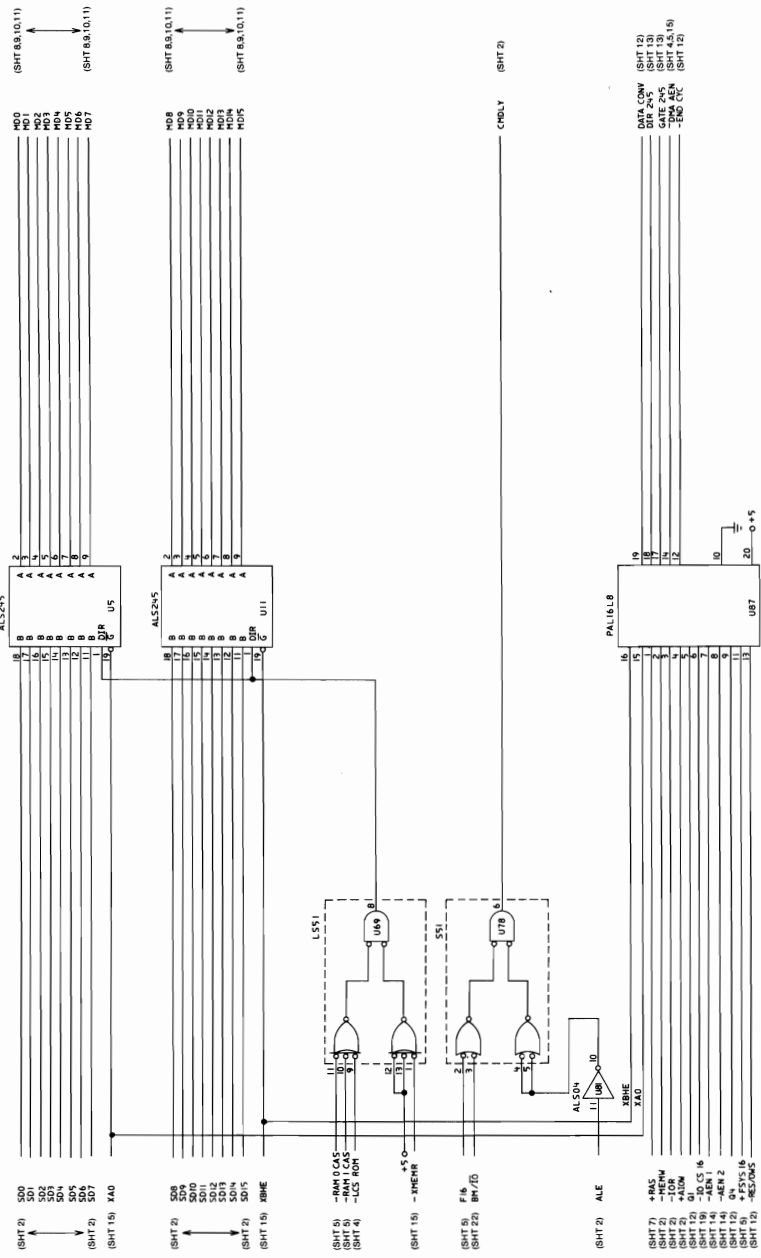

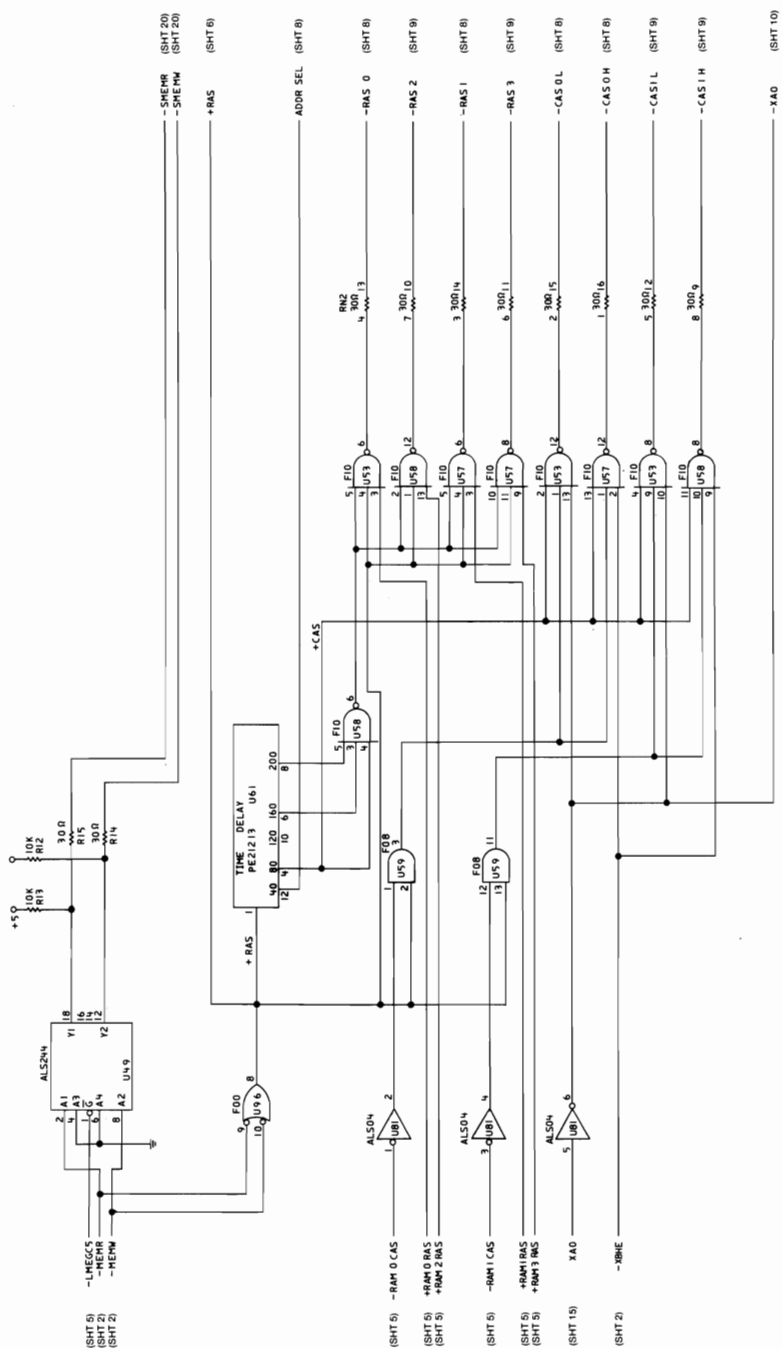

System Board (Sheet 7 of 22)

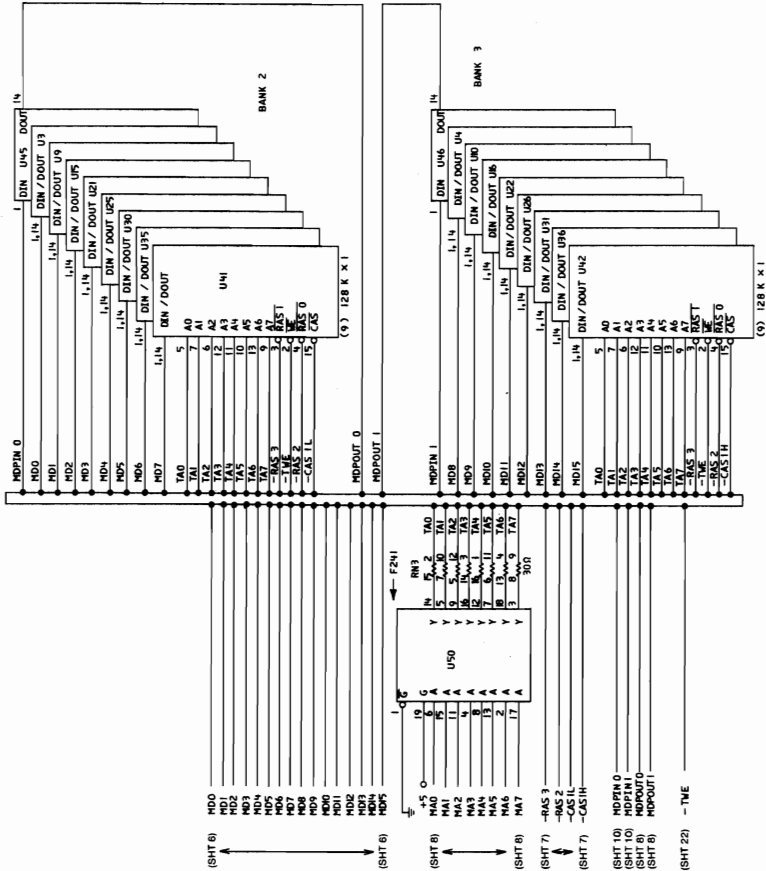

DECOUPLING CAPS NOMINAL VALUE TO GND	
+ 5	9 - .0uF
+ 5	2 - .0uF
3	2 - .0uF

10uF : C3,N,5H,55
 .10uF: C9,13,16,22,30
 3uM0,N4,N9
 C10,14,19,23,31
 35,N4,N5,50

System Board (Sheet 9 of 22)

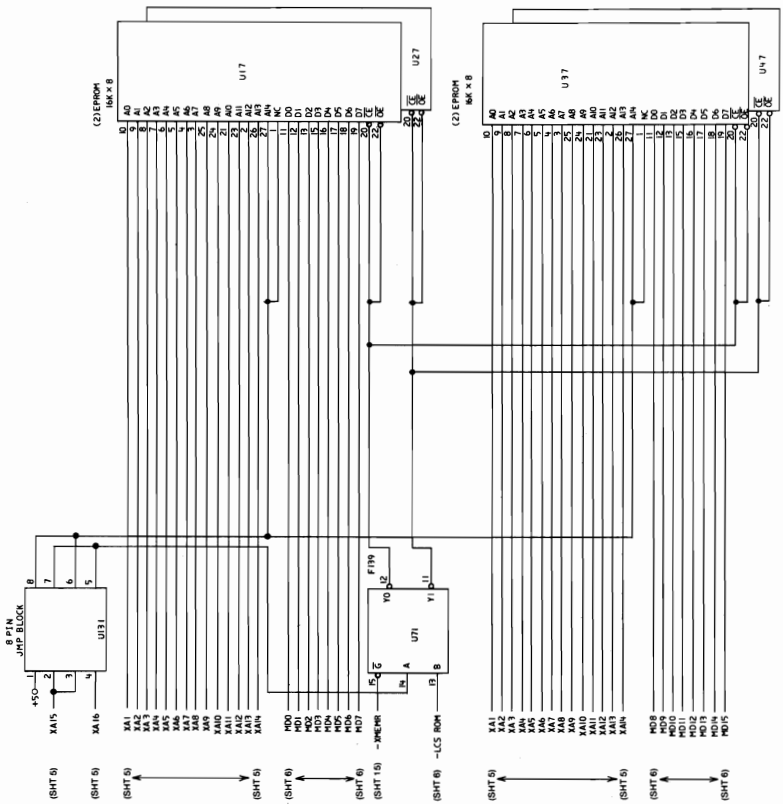

System Board (Sheet 10 of 22)

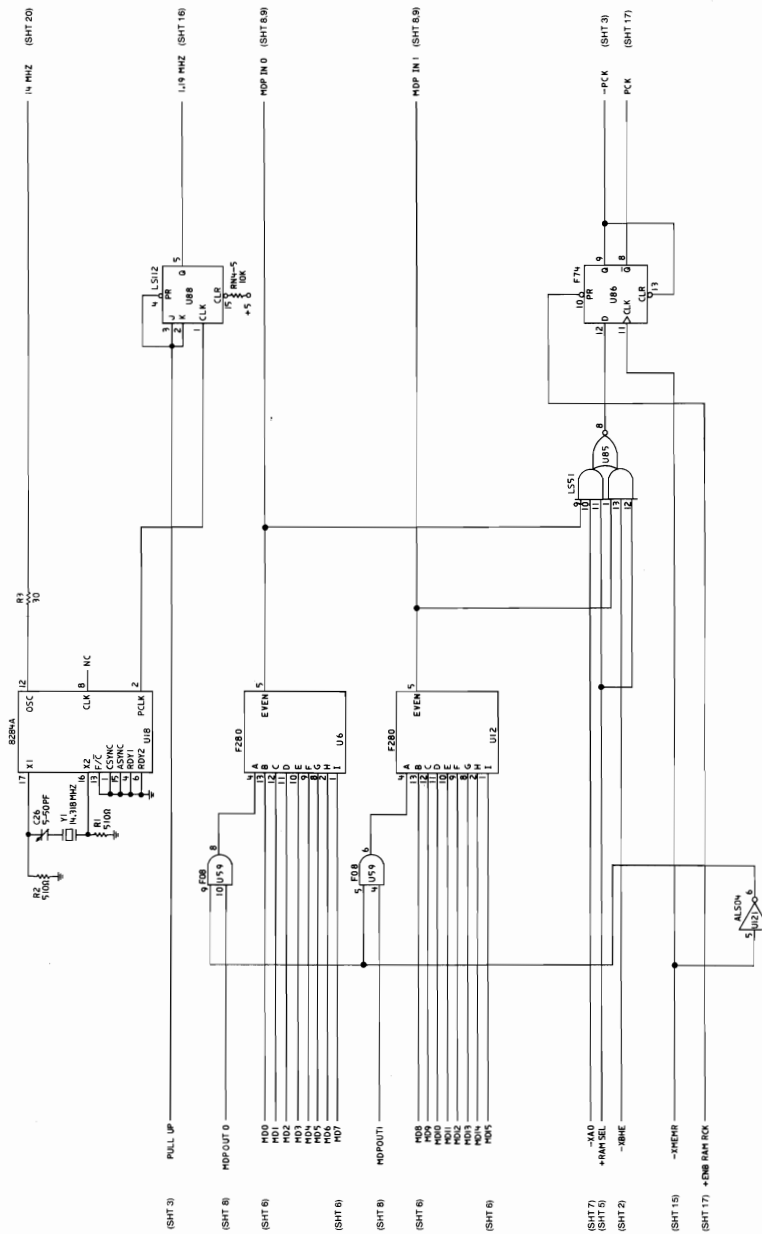

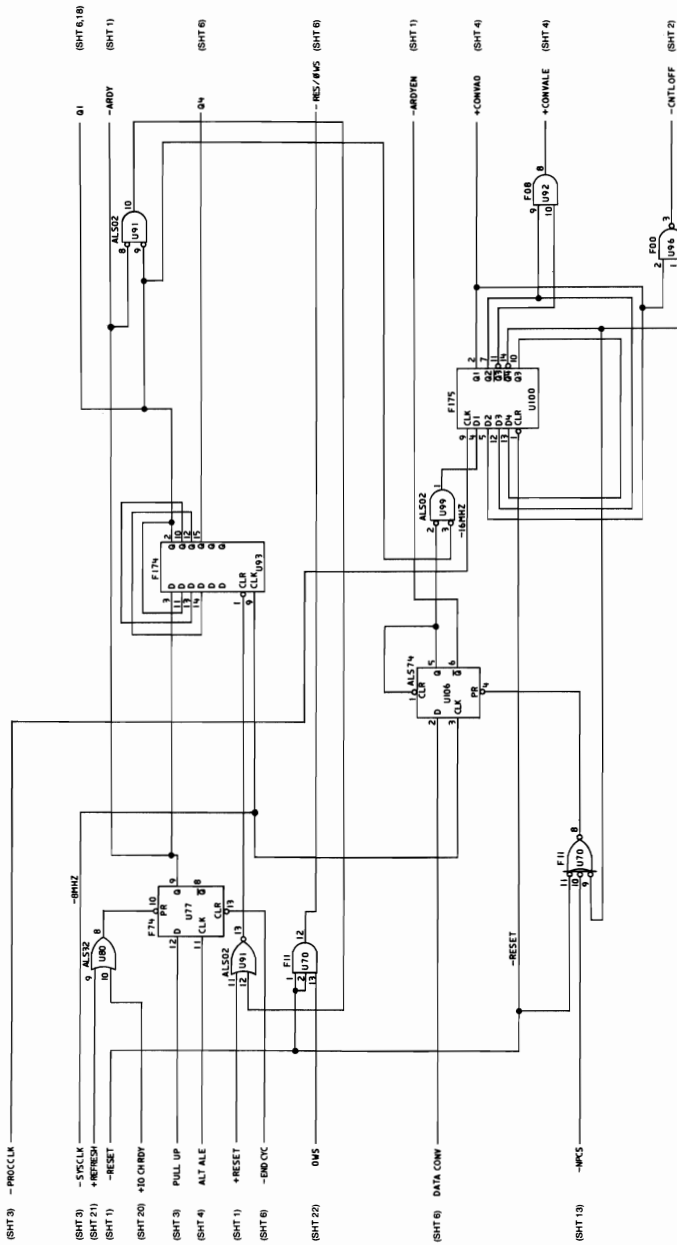

System Board (Sheet 12 of 22)

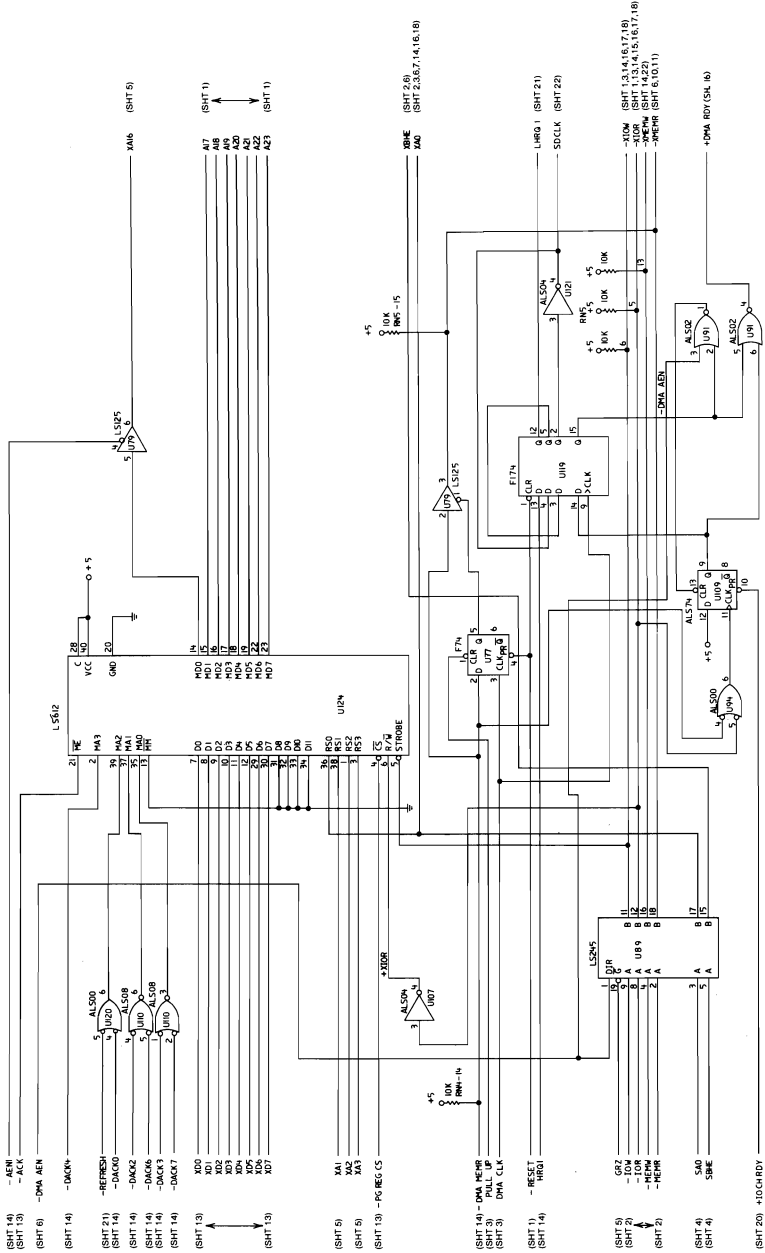

System Board (Sheet 15 of 22)

System Board (Sheet 16 of 22)

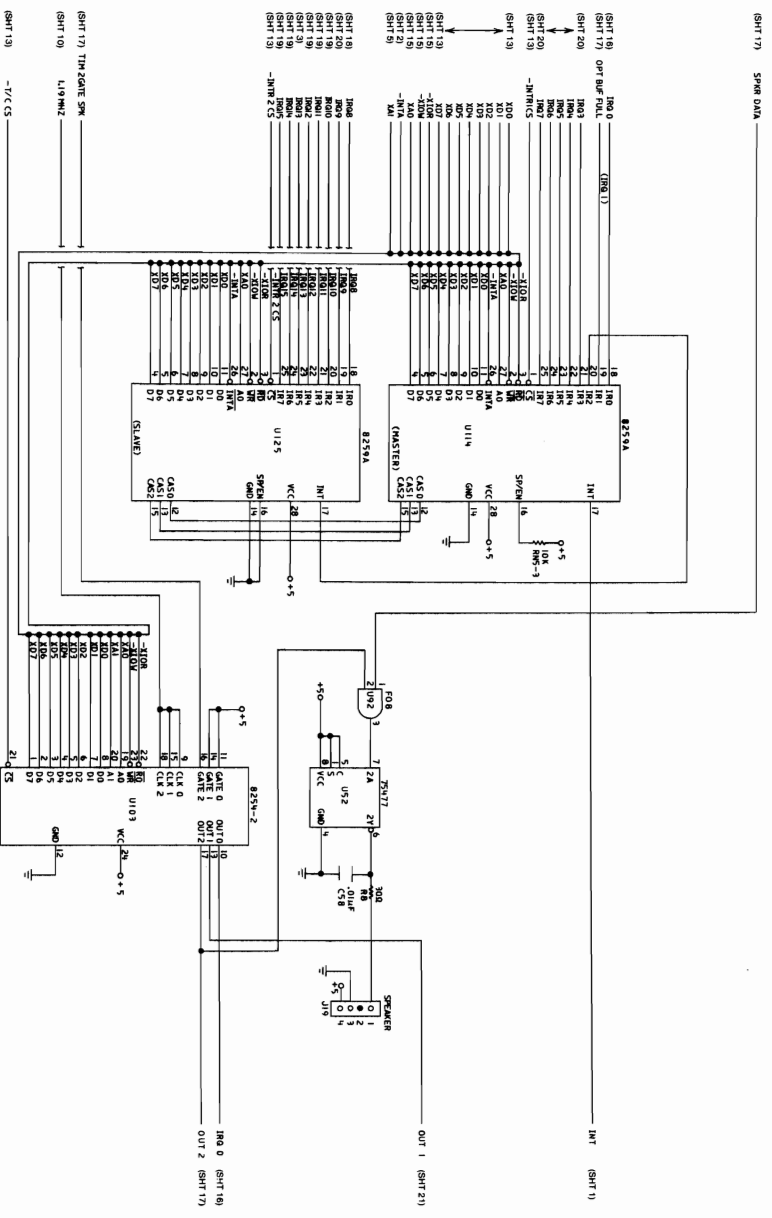

System Board (Sheet 17 of 22)

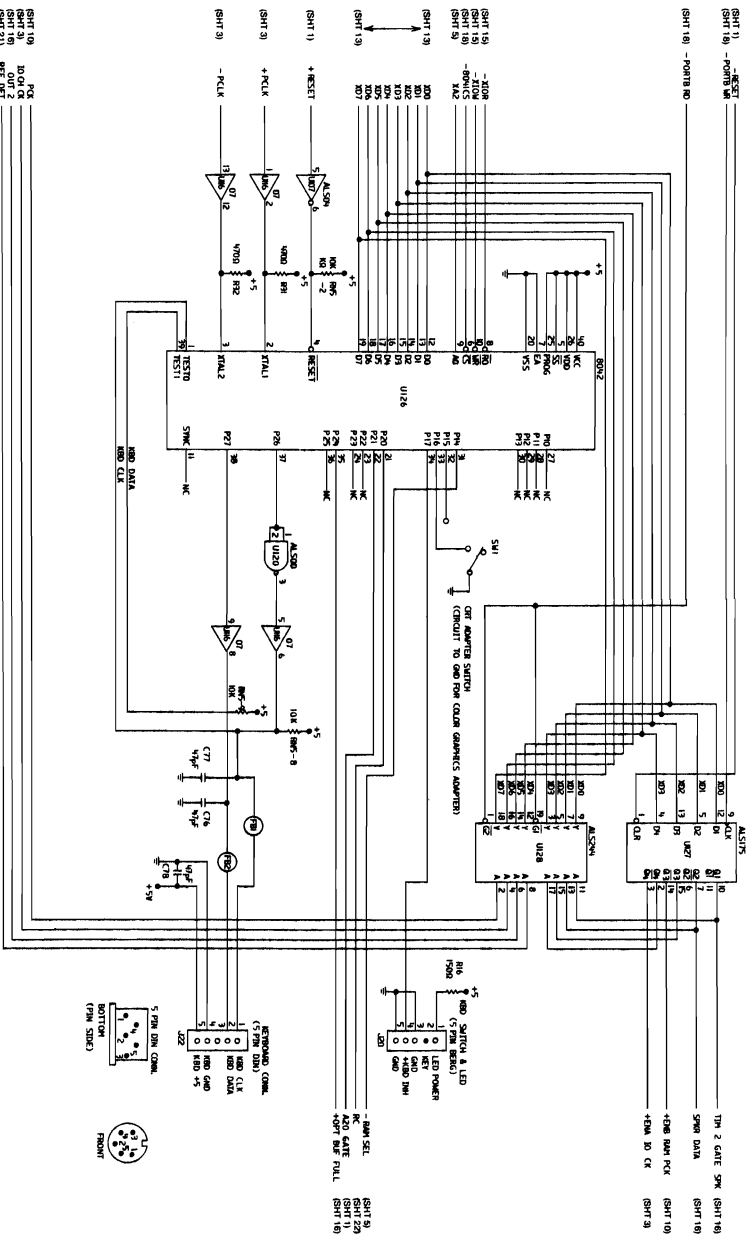

1-78 System Board

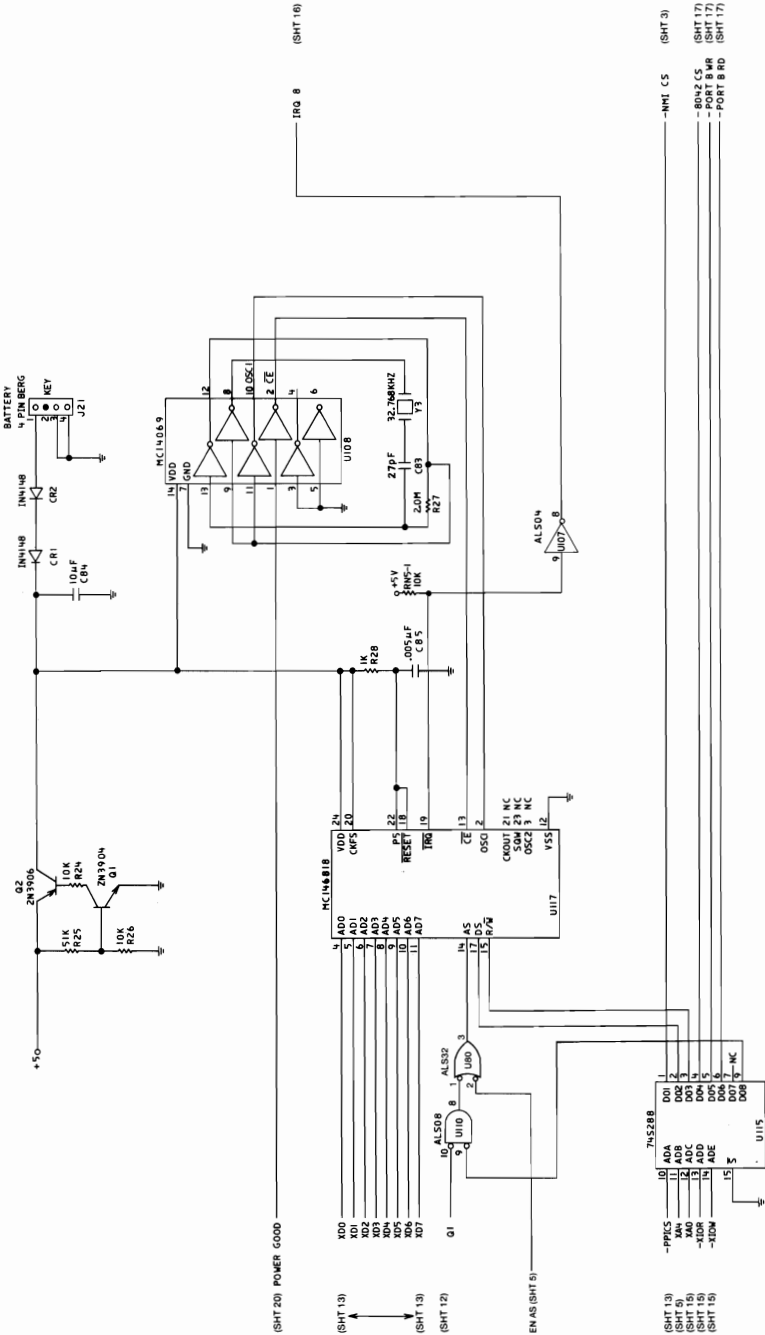

System Board (Sheet 18 of 22)

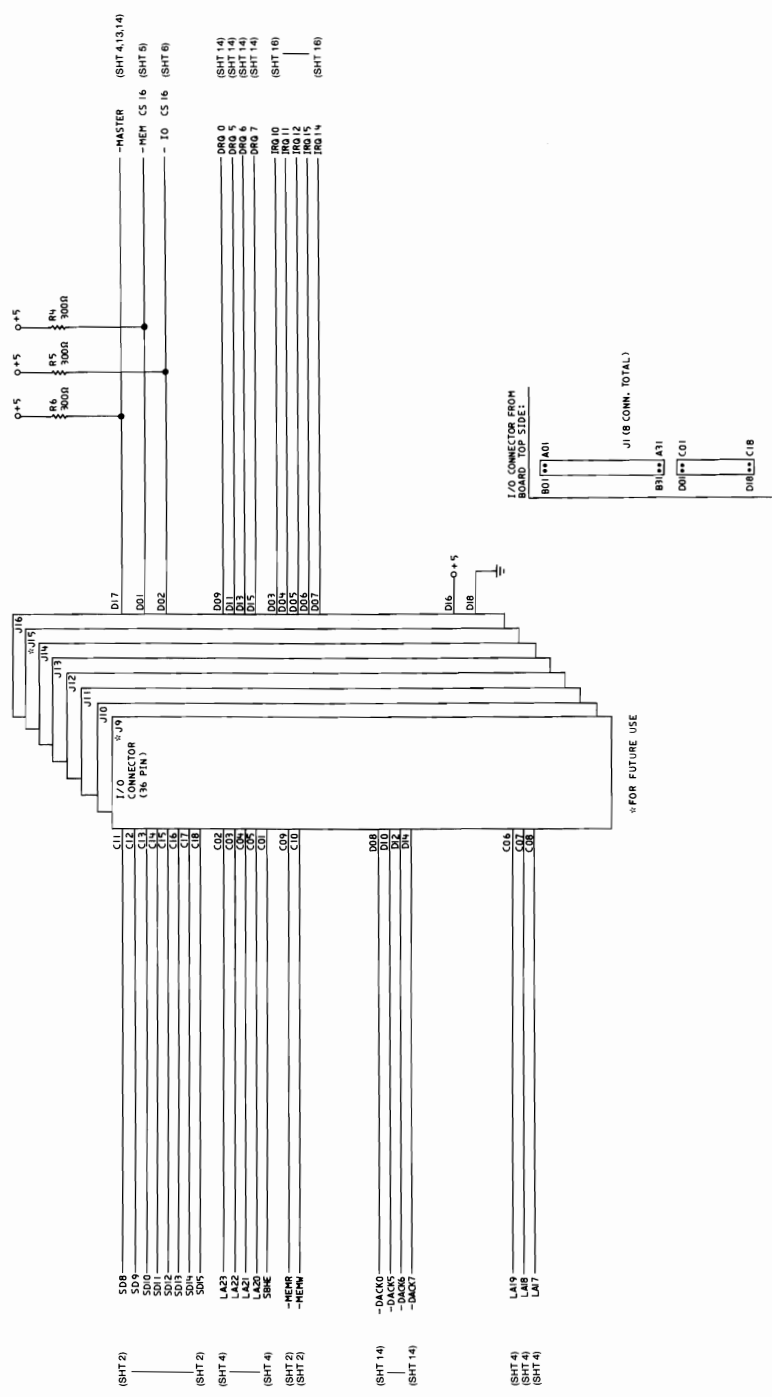

System Board (Sheet 19 of 22)

1-82 System Board

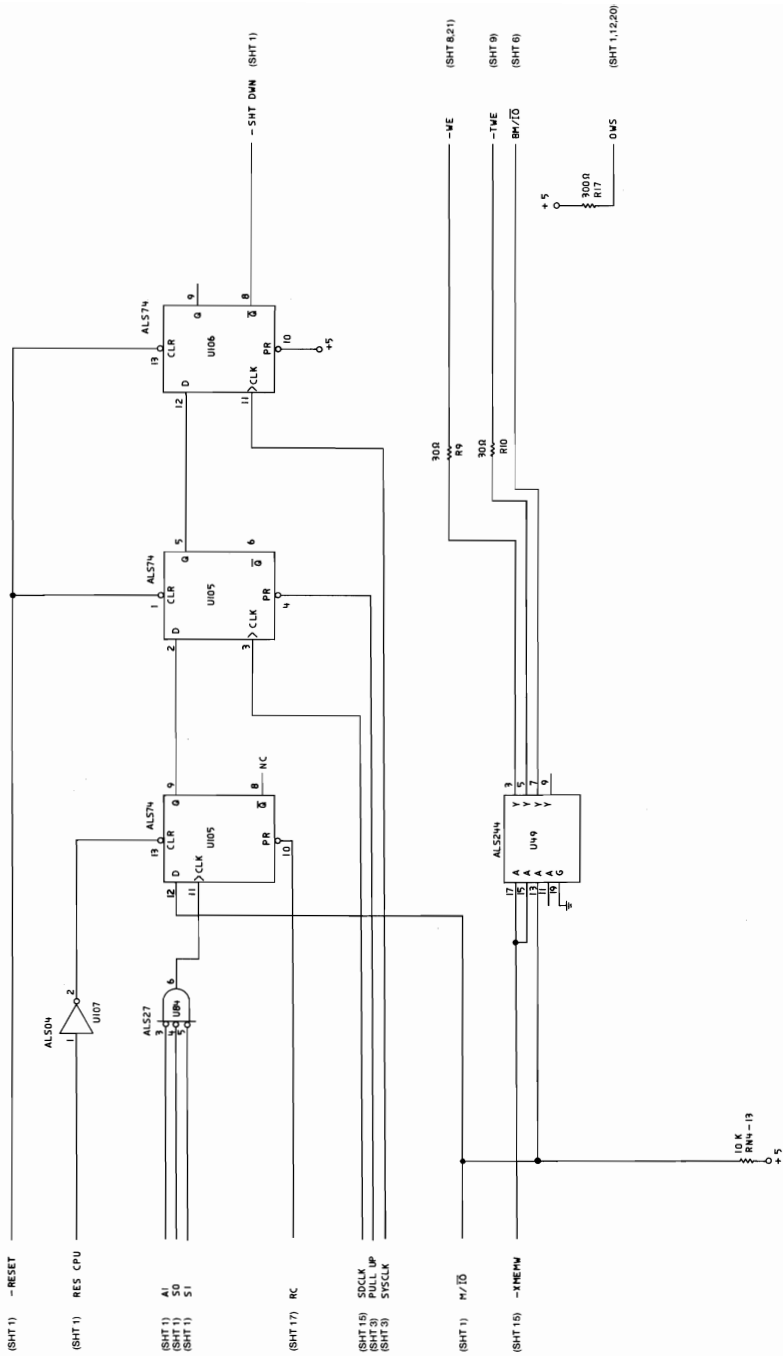

System Board (Sheet 22 of 22)

SECTION 2. COPROCESSOR

Contents

Description	2-3
Programming Interface	2-3
Hardware Interface	2-4

Notes:

Description

The IBM Personal Computer AT Math Coprocessor enables the IBM Personal Computer AT to perform high-speed arithmetic, logarithmic functions, and trigonometric operations with extreme accuracy.

The coprocessor works in parallel with the microprocessor. The parallel operation decreases operating time by allowing the coprocessor to do mathematical calculations while the microprocessor continues to do other functions.

The coprocessor works with seven numeric data types, which are divided into the following three classes:

- Binary integers (3 types)
- Decimal integers (1 type)
- Real numbers (3 types)

Programming Interface

The coprocessor offers extended data types, registers, and instructions to the microprocessor.

The coprocessor has eight 80-bit registers, which provide the equivalent capacity of the 40 16-bit registers in the microprocessor. This register space allows constants and temporary results to be held in registers during calculations, thus reducing memory access and improving speed as well as bus availability. The register space can be used as a stack or as a fixed register set. When used as a stack, only the top two stack elements are operated on. The following figure shows representations of large and small numbers in each data type.

Data Type	Bits	Significant Digits (Decimal)	Approximate Range (Decimal)
Word Integer	16	4	$-32,768 \leq x \leq +32,767$
Short Integer	32	9	$-2 \times 10^9 \leq x \leq +2 \times 10^9$
Long Integer	64	19	$-9 \times 10^{18} \leq x \leq +9 \times 10^{18}$
Packed Decimal	80	18	$-99...99 \leq x \leq +99...99$ (18 digits)
Short Real *	32	6-7	$8.43 \times 10^{-37} \leq x \leq 3.37 \times 10^{38}$
Long Real *	64	15-16	$4.19 \times 10^{-307} \leq x \leq 1.67 \times 10^{308}$
Temporary Real	80	19	$3.4 \times 10^{-4932} \leq x \leq 1.2 \times 10^{4932}$

Data Types

* The Short and Long data types correspond to the single and double precision data types.

Hardware Interface

The math coprocessor uses the same clock generator as the microprocessor. It works at one-third the frequency of the system microprocessor clock. The coprocessor is wired so that it functions as an I/O device through I/O port addresses hex 00F8, 00FA, and 00FC. The microprocessor sends OP codes and operands through these I/O ports. The microprocessor also receives and stores results through the same I/O ports. The coprocessor's busy signal informs the microprocessor that it is executing; the microprocessor's Wait instruction forces the microprocessor to wait until the coprocessor is finished executing.

The coprocessor detects six different exception conditions that can occur during instruction execution. If the appropriate exception mask within the coprocessor is not set, the coprocessor sets its error signal. This error signal generates a hardware interrupt (interrupt 13) and causes the 'BUSY' signal to the coprocessor to be held in the busy state. The 'BUSY' signal may be cleared by an 8-bit I/O Write command to address hex F0 with D0 through D7 equal to 0.

The power-on-self test code in the system ROM enables hardware interrupt 13 and sets up its vector to point to a routine in ROM. The ROM routine clears the 'BUSY' signal's latch and

then transfers control to the address pointed to by the NMI interrupt vector. This allows code written for any IBM Personal Computer to work on an IBM Personal Computer AT. The NMI interrupt handler should read the coprocessor's status to determine if the NMI was caused by the coprocessor. If the interrupt was not generated by the coprocessor, control should be passed to the original NMI interrupt handler.

The coprocessor has two operating modes similar to the two modes of the microprocessor. When reset by a power-on reset or an I/O write operation to port hex 00F1, the coprocessor is in the real address mode. This mode is compatible with the 8087 Math Coprocessor used in other IBM Personal Computers. The coprocessor can be placed in the protected mode by executing the SETPM ESC instruction. It can be placed back in the real mode by an I/O write operation to port hex 00F1, with D7 through D0 equal to 0.

The coprocessor instruction extensions to the microprocessor can be found in Section 6 of this manual.

Detailed information for the internal functions of the Intel 80287 coprocessor can be found in books listed in the Bibliography.

Notes:



SECTION 3. POWER SUPPLY

Contents

Inputs	3-3
Outputs	3-3
Output Protection	3-4
Dummy Load	3-4
Output Voltage Sequencing	3-4
No-Load Operation	3-5
Power-Good Signal	3-5
Fan-Out	3-6
Connectors	3-6

Notes:



The system's power supply is contained *inside* of the system unit and provides power for the system board, the adapters, the diskette drives, the fixed disk drives, the keyboard, and the IBM Monochrome Display.

Inputs

The power supply can operate at a frequency of either 60 ± 3 Hz or 50 ± 3 Hz and it can operate at 110 Vac, 5 A or 220/240 Vac, 2.5 A. The voltage is selected with the switch above the power-cord plug at the rear of the power supply. The following figure shows the input requirements.

Range	Voltage (Vac)	Current (Amperes)
115 Vac	Minimum 100	Maximum 5
	Maximum 125	
230 Vac	Minimum 200	Maximum 3.0
	Maximum 240	

Input Requirements

Note: The maximum in-rush current is 100 A.

Outputs

The power supply provides +5, -5, +12, and -12 Vdc. The following figure shows the load current and regulation tolerance for the voltages.

Note: The power supply also supplies either 115 Vac or 230 Vac for the IBM Monochrome Display.

Nominal Output	Load Current (A)		Regulation Tolerance
	Min	Max	
+5 Vdc	7.0	19.8	+5% to -4%
-5 Vdc	0.0	0.3	+10% to -8%
+12 Vdc	2.5	7.3	+5% to -4%
-12 Vdc	0.0	0.3	+10% to -9%

DC Load Requirements

Output Protection

If any output becomes overloaded, the power supply will switch off within 20 milliseconds. An overcurrent condition will not damage the power supply.

Dummy Load

If no fixed disk drive is connected to the power supply, the Dummy Load must be connected to P10. The Dummy Load is a 5 ohm, 50 watt resistor.

Output Voltage Sequencing

Under normal conditions, the output voltage levels track within 300 milliseconds of each other when power is applied to, or removed from the power supply, provided at least minimum loading is present.

No-Load Operation

No damage or hazardous conditions occur when primary power is applied with no load on any output level. In such cases, the power supply may switch off, and a power/on cycle will be required. The power supply requires a minimum load for proper operation.

Power-Good Signal

The power supply provides a 'power-good' signal to indicate proper operation of the power supply.

When the supply is switched off for a minimum of 1 second and then switched on, the 'power-good' signal is generated, assuming there are no problems. This signal is a logical AND of the dc output-voltage sense signal and the ac input-voltage sense signal. The power-good signal is also a TTL-compatible high level for normal operation, or a low level for fault conditions. The ac fail signal causes power-good to go to a low level at least 1 millisecond before any output voltage falls below the regulation limits. The operating point used as a reference for measuring the 1 millisecond is normal operation at minimum line voltage and maximum load.

The dc output-voltage sense signal holds the 'power-good signal' at a low level when power is switched on until all output voltages have reached their minimum sense levels. The 'power-good signal' has a turn-on delay of at least 100 milliseconds but not longer than 500 milliseconds. The following figure shows the minimum sense levels for the output voltages.

Level (Vdc)	Minimum (Vdc)
+5	+4.5
-5	-3.75
+12	+10.8
-12	-10.4

Sense Levels

Fan-Out

Fan-out is the number of inputs that one output can drive. The 'power-good' signal can drive six standard TTL loads.

Connectors

The following figure shows the pin assignments for the power-supply output connectors.

Load Point	Voltage (Vdc)	Max. Current (A)
PS8-1	Power Good	See note
PS8-2	+5	3.8
PS8-3	+12	0.7
PS8-4	-12	0.3
PS8-5	Ground	0.0
PS8-6	Ground	0.0
PS9-1	Ground	0.0
PS9-2	Ground	0.0
PS9-3	-5	0.3
PS9-4	+5	3.8
PS9-5	+5	3.8
PS9-6	+5	3.8
P10-1	+12	2.8
P10-2	Ground	0.0
P10-3	Ground	0.0
P10-4	+5	1.8
P11-1	+12	2.8
P11-2	Ground	0.0
P11-3	Ground	0.0
P11-4	+5	1.8
P12-1	+12	1.0
P12-2	Ground	0.0
P12-3	Ground	0.0
P12-4	+5	0.6

DC Load Distribution

Note: For more details, see 'Power-Good Signal'.

Notes:



SECTION 4. KEYBOARD

Contents

Description	4-3
Interface	4-3
Sequencing Key Code Scanning	4-3
Keyboard Buffer	4-3
Keys	4-3
Functions Performed at Power-On Time	4-4
Power-On Reset	4-4
Basic Assurance Test	4-4
Commands from the System	4-5
Reset (Hex FF)	4-5
Resend (Hex FE)	4-6
No-Operation (NOP) (Hex FD through F7)	4-6
Set Default (Hex F6)	4-6
Default Disable (Hex F5)	4-6
Enable (Hex F4)	4-6
Set Typematic Rate/Delay (Hex F3)	4-7
No-Operation (NOP) (Hex F2 through EF)	4-8
Echo (Hex EE)	4-8
Set/Reset Mode Indicators (Hex ED)	4-8
Keyboard Outputs	4-10
Key Scan Codes	4-10
Command Codes to the System	4-12
Resend (Hex FE)	4-12
ACK (Hex FA)	4-12
Overrun (Hex 00)	4-13
Diagnostic Failure (Hex FD)	4-13
Break Code Prefix (Hex F0)	4-13
BAT Completion Code (Hex AA)	4-13
ECHO Response (Hex EE)	4-13

Clock and Data Signals **4-14**
 Keyboard Data Output 4-15
 Keyboard Data Input 4-15

Keyboard Layout **4-16**
 U.S. English Keyboard 4-17
 U.K. English Keyboard 4-18
 French Keyboard 4-19
 German Keyboard 4-20
 Italian Keyboard 4-21
 Spanish Keyboard 4-22

Specifications **4-23**
 Size 4-23
 Weight 4-23
 Keyboard Connector 4-23

Description

The keyboard is a low-profile, 84 key, detachable unit.

Interface

The keyboard uses a bidirectional serial interface to carry signals between the keyboard and system unit.

Sequencing Key Code Scanning

The keyboard is able to detect all keys that are pressed, and their scan codes will be sent to the interface in correct sequence, regardless of the number of keys held down. Keystrokes entered while the interface is inhibited (when the keylock is on) will be lost. Keystrokes are stored only when the keyboard is not serviced by the system.

Keyboard Buffer

The keyboard has a 16-character first-in-first-out (FIFO) buffer where data is stored until the interface is ready to receive it.

A buffer-overflow condition will occur if more than sixteen codes are placed in the buffer before the first keyed data is sent. The seventeenth code will be replaced with the overflow code, hex 00. (The 17th position is reserved for overflow codes). If more keys are pressed before the system allows a keyboard output, the data will be lost. When the keyboard is allowed to send data, the characters in the buffer will be sent as in normal operation, and new data entered will be detected and sent.

Keys

All keys are classified as *make/break*, which means when a key is pressed, the keyboard sends a make code for that key to the

keyboard controller. When the key is released, its break code is sent (the break code for a key is its make code preceded by hex FO).

All keys are typematic. When a key is pressed and held down, the keyboard continues to send the make code for that key until the key is released. The rate at which the make code is sent is known as the typematic rate (The typematic rate is described under "Set Typematic Rate/Delay"). When two or more keys are held down, only the last key pressed repeats at the typematic rate. Typematic operation stops when the last key pressed is released, even if other keys are still held down. When a key is pressed and held down while the interface is inhibited, only the first make code is stored in the buffer. This prevents buffer overflow as a result of typematic action.

Functions Performed at Power-On Time

Power-On Reset

The keyboard logic generates a POR when power is applied to the keyboard. The POR lasts a minimum of 300 milliseconds and a maximum of 9 seconds.

Note: The keyboard may issue a false return during the first 200 milliseconds after the +5 Vdc is established at the 90% level. Therefore, the keyboard interface is disabled for this period.

Basic Assurance Test

Immediately following the POR, the keyboard executes a basic assurance test (BAT). This test consists of a checksum of all read-only memory (ROM), and a stuck-bit and addressing test of all random-access memory (RAM) in the keyboard's microprocessor. The mode indicators—three light emitting diodes

(LEDs) on the upper right-hand corner of the keyboard—are turned on then off, and must be observed to ensure they are operational.

Execution of the BAT will take from 600 to 900 milliseconds. (This is in addition to the time required for the POR.)

The BAT can also be started by a Reset command.

After the BAT, and when the interface is enabled ('clock' and 'data' lines are set high), the keyboard sends a completion code to the interface—either hex AA for satisfactory completion or hex FC (or any other code) for a failure. If the system issues a Resend command, the keyboard sends the BAT completion code again. Otherwise, the keyboard sets the keys to typematic and make/break.

Commands from the System

The commands described below may be sent to the keyboard at any time. The keyboard will respond within 20 milliseconds.

Note: The following commands are those sent by the system. They have a different meaning when issued by the keyboard.

Reset (Hex FF)

The system issues a Reset command to start a program reset and a keyboard internal self-test. The keyboard acknowledges the command with an 'acknowledge' signal (ACK) and ensures the system accepts the 'ACK' before executing the command. The system signals acceptance of the 'ACK' by raising the clock and data for a minimum of 500 microseconds. The keyboard is disabled from the time it receives the Reset command until the 'ACK' is accepted or until another command overrides the previous one. Following acceptance of the 'ACK', the keyboard

begins the reset operation, which is similar to a power-on reset. The keyboard clears the output buffer and sets up default values for typematic and delay rates.

Resend (Hex FE)

The system can send this command when it detects an error in any transmission from the keyboard. It can be sent only after a keyboard transmission and before the system enables the interface to allow the next keyboard output. Upon receipt of Resend, the keyboard sends the previous output again unless the previous output was Resend. In this case, the keyboard will resend the last byte before the Resend command.

No-Operation (NOP) (Hex FD through F7)

These commands are reserved and are effectively no-operation or NOP. The system does not use these codes. If sent, the keyboard will acknowledge the command and continue in its prior scanning state. No other operation will occur.

Set Default (Hex F6)

The Set Default command resets all conditions to the power-on default state. The keyboard responds with 'ACK', clears its output buffer, sets default conditions, and continues scanning (only if the keyboard was previously enabled).

Default Disable (Hex F5)

This command is similar to Set Default, except the keyboard stops scanning and awaits further instructions.

Enable (Hex F4)

Upon receipt of this command, the keyboard responds with 'ACK', clears its output buffer, and starts scanning.

Set Typematic Rate/Delay (Hex F3)

The system issues this command, followed by a parameter, to change the typematic rate and delay. The typematic rate and delay parameters are determined by the value of the byte following the command. Bits 6 and 5 serve as the delay parameter and bits 4, 3, 2, 1, and 0 (the least-significant bit) are the rate parameter. Bit 7, the most-significant bit, is always 0. The delay is equal to 1 plus the binary value of bits 6 and 5 multiplied by 250 milliseconds $\pm 20\%$. The period (interval from one typematic output to the next) is determined by the following equation:

Period = $(8 + A) \times (2^B) \times 0.00417$ seconds, where A = binary value of bits 2, 1, and 0 and B = binary value of bits 4 and 3.

The typematic rate (make code per second) is $1/\text{period}$. The period is determined by the first equation above. The following table results.

Bit Rate	Bit Rate
00000 30.0	10000 7.5
00001 26.7	10001 6.7
00010 24.0	10010 6.0
00011 21.8	10011 5.5
00100 20.0	10100 5.0
00101 18.5	10101 4.6
00110 17.1	10110 4.3
00111 16.0	10111 4.0
01000 15.0	11000 3.7
01001 13.3	11001 3.3
01010 12.0	11010 3.0
01011 10.9	11011 2.7
01100 10.0	11100 2.5
01101 9.2	11101 2.3
01110 8.6	11110 2.1
01111 8.0	11111 2.0

Typematic Rate

The keyboard responds to the Set Typematic Rate Delay command with an 'ACK', stops scanning, and waits for the rate parameter. The keyboard responds to the rate parameter with another 'ACK', sets the rate and delay, and continues scanning (if the keyboard was previously enabled). If a command is received instead of the rate parameter, the set-typematic-rate

function ends with no change to the existing rate, and the new command is processed. However, the keyboard will not resume scanning unless instructed to do so by an Enable command.

The default rate for the system keyboard is as follows:

The typematic rate = 10 characters per second $\pm 20\%$ and the delay = 500 ms $\pm 20\%$.

No-Operation (NOP) (Hex F2 through EF)

These commands are reserved and are effectively no-operation (NOP). The system does not use these codes. If sent, the keyboard acknowledges the command and continues in its prior scanning state. No other operation will occur.

Echo (Hex EE)

Echo is a diagnostic aide. When the keyboard receives this command, it issues a hex EE response and continues scanning if the keyboard was previously enabled.

Set/Reset Mode Indicators (Hex ED)

Three mode indicators on the keyboard are accessible to the system. The keyboard activates or deactivates these indicators when it receives a valid command from the system. They can be activated or deactivated in any combination.

It is up to the using system to remember the previous state of an indicator. This is in case its setting does not change when a command sequence is issued to change the state of another indicator.

The system remembers the previous state of an indicator so that its setting does not change when a command sequence is issued to change the state of another indicator.

The command has the following format:

Command	Options
---------	---------

Set/Reset Command

A Set/Reset Mode Indicators command consists of two bytes. The first is the command byte and has the following bit setup:

11101101 – hex ED

The second byte is an option byte. It has a list of the indicators to be acted upon. The format of the option byte is as follows:

- Bit 7 Reserved
- Bit 6 Reserved
- Bit 5 Reserved
- Bit 4 Reserved
- Bit 3 Reserved
- Bit 2 Caps Lock indicator
- Bit 1 Numeric Lock indicator
- Bit 0 Scroll Lock indicator

Note: Bit 7 is the most-significant bit; bit 0 is the least-significant.

The keyboard will respond to the Set/Reset Mode Indicators command with an 'ACK', discontinue scanning, and wait for the option byte. The keyboard will respond to the option byte with an Ack, set the indicators, and continue scanning if the keyboard was previously enabled. If another command is received in place of the option byte, execution of the function of the Set/Reset Mode Indicators command is stopped with no change to the indicator states, and the new command is processed. Then scanning is resumed.

Keyboard Outputs

Key Scan Codes

Each key is assigned a unique 8-bit, make, scan code, which is sent when the key is pressed. Each key also sends a break code when the key is released. The break code consists of two bytes, the first of which is the break code prefix, hex F0; the second byte is the same as the make scan code for that key.

The typematic scan code for a key is the same as the key's make code. The following figure is a keyboard layout.

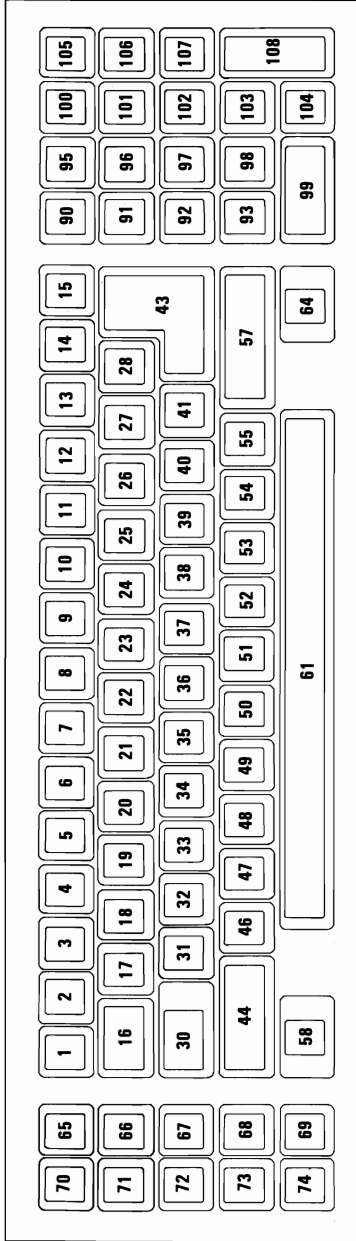

The following figure lists the positions of the keys and their make scan codes.

Key Positions and Their Make Codes				
1--DE	18--1D	36--33	55--4A	90--76
2--16	19--24	37--3B	56--51	91--6C
3--1E	20--2D	38--42	57--59	92--6B
4--26	21--2C	39--4B	58--11	93--69
5--25	22--35	40--4C	60--19	94--77
6--2E	23--3C	41--52	61--29	96--75
7--36	24--43	43--5A	64--58	97--73
8--3D	25--44	44--12	65--D6	98--72
9--3E	26--4D	46--1A	66--DC	99--70
10--46	27--54	47--22	67--0B	100--7E
11--45	28--5B	48--21	68--0A	101--7D
12--4E	30--14	49--2A	69--09	102--74
13--55	31--1C	50--32	70--05	103--7A
14--5D	32--1B	51--31	71--04	104--71
15--66	33--23	52--3A	72--D3	105--84
16--0D	34--2B	53--41	73--83	106--7C
17--15	35--34	54--49	74--01	107--7B

Make Scan Codes

Command Codes to the System

The command codes described here are those sent by the keyboard. The codes have a different meaning when issued by the system.

Resend (Hex FE)

The keyboard issues a Resend command following receipt of an invalid input, or any input with incorrect parity. If the system sends nothing to the keyboard, no response is required.

ACK (Hex FA)

The keyboard issues an 'ACK' response to any valid input other than an Echo or Resend command. If the keyboard is interrupted

while sending 'ACK', it will discard 'ACK' and accept and respond to the new command.

Overrun (Hex 00)

An overrun character is placed in position 17 of the keyboard buffer, overlaying the last code if the buffer becomes full. The code is sent to the system as an overrun when it reaches the top of the buffer.

Diagnostic Failure (Hex FD)

The keyboard periodically tests the sense amplifier and sends a diagnostic failure code if it detects any problems. If a failure occurs during BAT, the keyboard stops scanning and waits for a system command or power-down to restart. If a failure is reported after scanning is enabled, scanning continues.

Break Code Prefix (Hex F0)

This code is sent as the first byte of a 2-byte sequence to indicate the release of a key.

BAT Completion Code (Hex AA)

Following satisfactory completion of the BAT, the keyboard sends hex AA. Hex FC (or any other code) means the keyboard microprocessor check failed.

ECHO Response (Hex EE)

This is sent in response to an Echo command from the system.

Clock and Data Signals

The keyboard and system communicate over the 'clock' and 'data' lines. The source of each of these lines is an open-collector device on the keyboard that allows either the keyboard or the system to force a line to a negative level. When no communication is occurring, both the 'clock' and 'data' lines are at a positive level.

Data transmissions to and from the keyboard consist of 11-bit data streams that are sent serially over the serial data line. The following figure shows the structure of the data stream.

Bit	Function
1st bit	0 start bit
2nd bit	Data bit 0 (least-significant)
3rd bit	Data bit 1
4th bit	Data bit 2
5th bit	Data bit 3
6th bit	Data bit 4
7th bit	Data bit 5
8th bit	Data bit 6
9th bit	Data bit 7 (most-significant)
10th bit	Parity bit (odd parity)
11th bit	Stop bit

Transmission Data Stream

The parity bit is either 1 or 0, and the eight data bits, plus the parity bit, always have an odd number.

When the system sends data to the keyboard, it forces the 'data' line to a negative level and allows the 'clock' line to go to a positive level.

When the keyboard sends data to, or receives data from the system, it generates the 'clock' signal to time the data. The system can prevent the keyboard from sending data by forcing the 'clock' line to a negative level; the 'data' line may go high or low during this time.

During the BAT, the keyboard allows the 'clock' and 'data' lines to go to a positive level.

Keyboard Data Output

When the keyboard is ready to send data, it first checks for a keyboard-inhibit or system request-to-send status on the 'clock' and 'data' lines. If the 'clock' line is low (inhibit status), data is stored in the keyboard buffer. If the 'clock' line is high and 'data' is low (request-to-send), data is stored in the keyboard buffer, and the keyboard receives system data.

If 'clock' and 'data' are both high, the keyboard sends the 0 start bit, 8 data bits, the parity bit and the stop bit. Data will be valid before the falling edge and beyond the rising edge of 'clock'. During transmission, the keyboard checks the 'clock' line for a positive level at least every 60 milliseconds. If the system lowers the 'clock' line from a positive level after the keyboard starts sending data, a condition known as *line contention* occurs, and the keyboard stops sending data. If line contention occurs before the rising edge of the tenth clock (parity bit), the keyboard buffer returns the 'data' and 'clock' lines to a positive level. If contention does not occur by the tenth clock, the keyboard completes the transmission.

Following a transmission, the system can inhibit the keyboard until the system processes the input or until it requests that a response be sent.

Keyboard Data Input

When the system is ready to send data to the keyboard, it first checks if the keyboard is sending data. If the keyboard is sending but has not reached the tenth clock, the system can override the keyboard output by forcing the 'clock' line to a negative level. If the keyboard transmission is beyond the tenth clock, the system must receive the transmission.

If the keyboard is not sending, or if the system elects to override the keyboard's output, the system forces the 'clock' line to a negative level for more than 60 microseconds while preparing to send. When the system is ready to send the start bit ('data' line will be low), it allows the 'clock' line to go to a positive level.

The keyboard checks the state of the 'clock' line at intervals of no less than 60 milliseconds. If a request-to-send is detected, the keyboard counts 11 bits. After the tenth bit, the keyboard forces the 'data' line low and counts one more (the stop bit). This action signals the system that the keyboard has received its data. Upon receipt of this signal, the system returns to a ready state, in which it can accept keyboard output, or goes to the inhibited state until it is ready.

Each system command or data transmission to the keyboard requires a response from the keyboard before the system can send its next output. The keyboard will respond within 20 milliseconds unless the system prevents keyboard output. If the keyboard response is invalid or has a parity error, the system sends the command or data again. A Resend command should not be sent in this case.

Keyboard Layout

The IBM Personal Computer AT Keyboard is available in six different layouts:

- U.S. English
- U.K. English
- French
- German
- Italian
- Spanish

The following pages show all six possible keyboard layouts.

U.K. English Keyboard

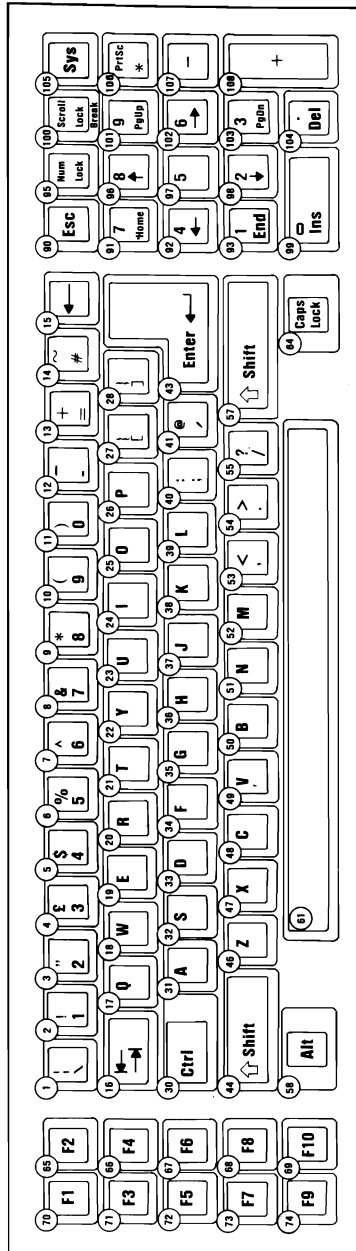

French Keyboard

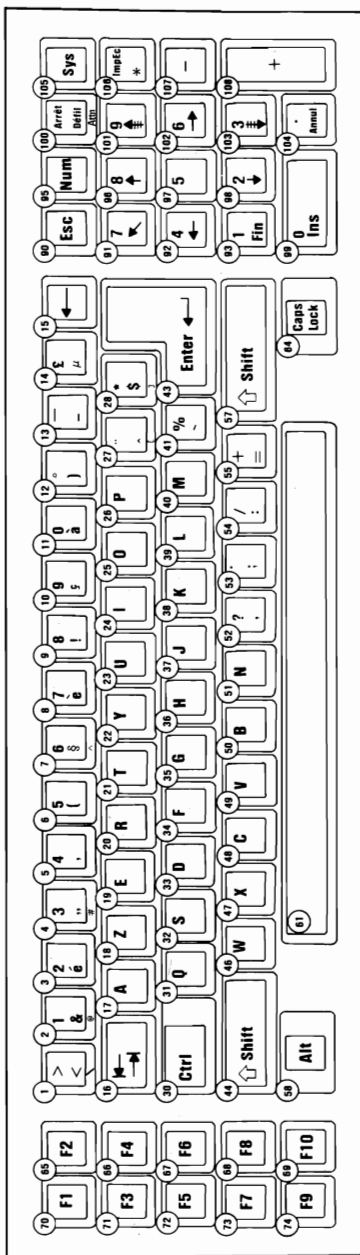

German Keyboard

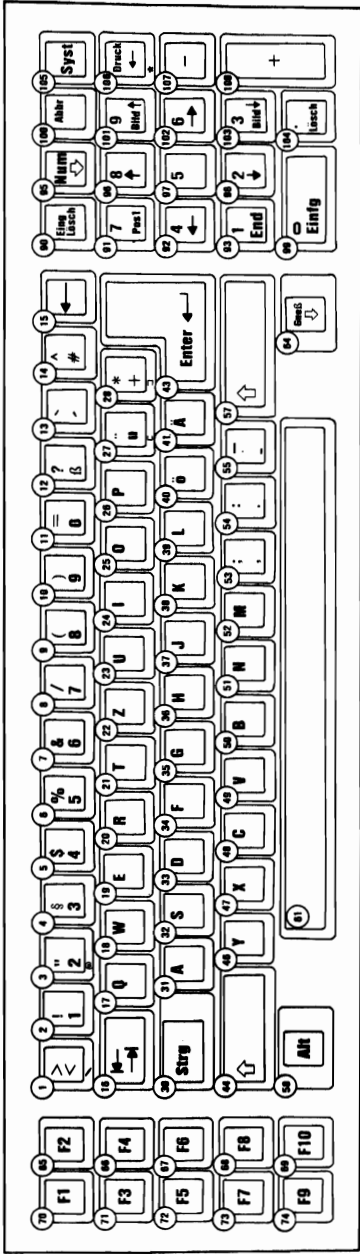

Italian Keyboard

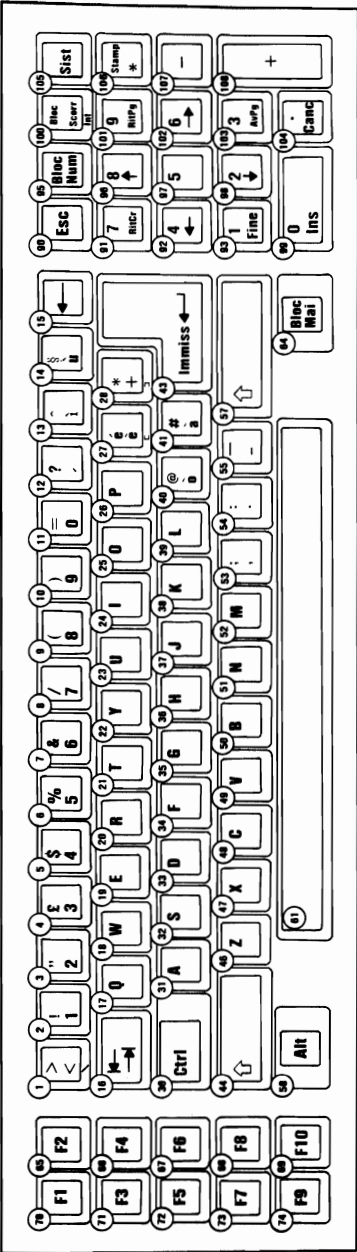

Spanish Keyboard

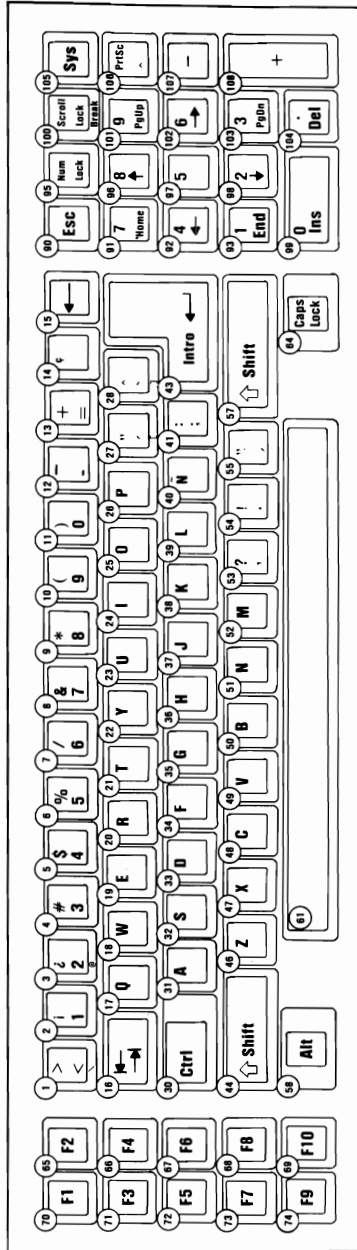

Specifications

Size

- Length: 540 millimeters (21.6 inches)
- Depth: 100 millimeters (4 inches)
- Height: 225 millimeters (9 inches)

Weight

- 2.8 kilograms (6.2 pounds)

Keyboard Connector

The keyboard cable connects to the system board through a 5-pin DIN connector. The following figure lists the connector pins and their signals.

Connector Pin	Signal Name
1	Clock
2	Data
3	Spare
4	Ground
5	+5 Vdc

Keyboard Connector

NOTES:

- 1 SOLDERING: THIS MANUFACTURING PROCESS MAY INCLUDE HAZARDOUS OPERATIONS AND REQUIRE SPECIAL HEALTH AND/OR SAFETY PRECAUTIONS.
- 2 POLARIZE P1 AT POSITION A3

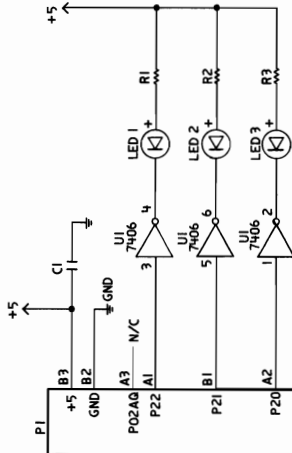
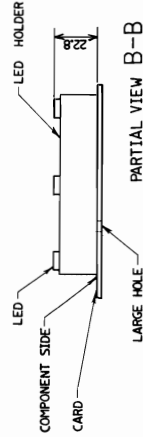
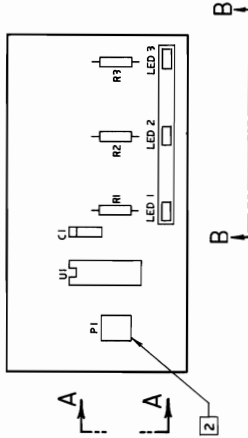
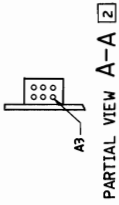

Enhancement Logic Card Assembly

SECTION 5. SYSTEM BIOS

Contents

System BIOS	5-3
System BIOS Usage	5-3
Parameter Passing	5-4
Vectors with Special Meanings	5-6
Other Read/Write Memory Usage	5-8
BIOS Programming Hints	5-10
Adapters with System-Accessible ROM Modules ..	5-11
System Board Additional ROM Modules	5-12
Keyboard Encoding and Usage	5-12
Encoding	5-12
Character Codes	5-13
Extended Codes	5-17
Extended Functions	5-17
Special Handling	5-21

Notes:



System BIOS

The basic input/output system (BIOS) resides in ROM on the system board and provides level control for the major I/O devices in the system. Additional ROM modules may be placed on option adapters to provide device level control for that option adapter. BIOS routines enable the assembler language programmer to perform block (disk or diskette) or character-level I/O operations without concern for device address and characteristics. System services, such as time-of-day and memory size determination, are provided by the BIOS.

If the sockets labeled U17 and U37 on the system board are empty, additional ROM modules may be placed in these sockets. During POST a test is made for valid code at this location, starting at address hex E0000 and ending at hex EFFFF. More information about these sockets may be found under "System Board Additional ROM Modules" later in this section.

The goal of the ROM BIOS is to provide an operational interface to the system and relieve the programmer of concern about the characteristics of hardware devices. The BIOS interface protects the user from the hardware, allowing new devices to be added to the system, yet retaining the BIOS level interface to the device. In this manner, hardware modifications and enhancements become transparent to user programs.

The *IBM Personal Computer MACRO Assembler* manual and the *IBM Personal Computer Disk Operating System (DOS)* manual provide useful programming information related to this section. A complete listing of the BIOS is given later in this section.

System BIOS Usage

Access to BIOS is through program interrupts of the 80286 in the real mode. Each BIOS entry point is available through its own interrupt. For example, to determine the amount of base RAM available in the system with the 80286 in the real mode, INT 12H will invoke the BIOS routine for determining the memory size and return the value to the caller.

Parameter Passing

All parameters passed to and from the BIOS routines go through the 80286 registers. The prolog of each BIOS function indicates the registers used on the call and return. For the memory size example, no parameters are passed. The memory size, in 1Kb increments, is returned in the AX register.

If a BIOS function has several possible operations, the AH register is used at input to indicate the desired operation. For example, to set the time of day, the following code is required:

```
MOV AH,1                ;function is to set time-of-day
MOV CX,HIGH COUNT      ;establish the current time
MOV DX,LOW COUNT
INT 1AH                ;set the time
```

To read the time of day:

```
MOV AH,0                ;function is to read time-of-day
INT 1AH                ;read the timer
```

The BIOS routines save all registers except for AX and the flags. Other registers are modified on return only if they are returning a value to the caller. The exact register usage can be seen in the prolog of each BIOS function.

The following figure shows the interrupts with their addresses and functions.

Address	Int	Name	BIOS Entry
0-3	0	Divide by Zero	D11
4-7	1	Single Step	D11
8-B	2	Nonmaskable	NMI INT
C-F	3	Breakpoint	D11
10-13	4	Overflow	D11
14-17	5	Print Screen	PRINT SCREEN
18-1B	6	Reserved	D11
1D-1F	7	Reserved	D11
20-23	8	Time of Day	TIMER INT
24-27	9	Keyboard	KB INT
28-2B	A	Reserved	D11
2C-2F	B	Communications	D11
30-33	C	Communications	D11
34-37	D	Alternate Printer	D11
38-3B	E	Diskette	DISK INT
3C-3F	F	Printer	D11
40-43	10	Video	VIDEO IO
44-47	11	Equipment Check	EQUIPMENT
48-4B	12	Memory	MEMORY SIZE
			DETERMINE
4C-4F	13	Diskette/Disk	DISKETTE IO
50-53	14	Communications	RS232 IO
54-57	15	Cassette	CASSETTE
			IO/System
			Extensions
58-5B	16	Keyboard	KEYBOARD IO
5C-5F	17	Printer	PRINTER IO
60-63	18	Resident BASIC	F600:0000
64-67	19	Bootstrap	BOOT STRAP
68-6B	1A	Time of Day	TIME OF DAY
6C-6F	1B	Keyboard Break	DUMMY RETURN
70-73	1C	Timer Tick	DUMMY RETURN
74-77	1D	Video Initialization	VIDEO PARMS
78-7B	1E	Diskette Parameters	DISK BASE
7C-7F	1F	Video Graphics Chars	0

80286 Program Interrupt Listing (Real Mode Only)

The following figure shows hardware, BASIC, and DOS reserved interrupts.

Address	Interrupt	Function
80-83	20	DOS program terminate
84-87	21	DOS function call
88-8B	22	DOS terminate address
8c-8F	23	DOS Ctrl Break exit address
90-93	24	DOS fatal error vector
94-97	25	DOS absolute disk read
98-9B	26	DOS absolute disk write
9C-9F	27	DOS terminate, fix in storage
A0-FF	28-3F	Reserved for DOS
100-17F	40-5F	Reserved
180-19F	60-67	Reserved for user program interrupts
1A0-1BF	68-6F	Not used
1C0-1C3	70	IRQ 8 Realtime clock INT (BIOS entry RTC__INT)
1C4-1C7	71	IRQ 9 (BIOS entry RE__DIRECT)
1C8-1CB	72	IRQ 10 (BIOS entry D11)
1CC-1CF	73	IRQ 11 (BIOS entry D11)
1D0-1D3	74	IRQ 12 (BIOS entry D11)
1D4-1D7	75	IRQ 13 BIOS Redirect to NMI interrupt (BIOS entry INT__287)
1D8-1DB	76	IRQ 14 (BIOS entry D11)
1DC-1DF	77	IRQ 15 (BIOS entry D11)
1E0-1FF	78-7F	Not used
200-217	80-85	Reserved by BASIC
218-3C3	86-F0	Used by BASIC interpreter while BASIC is running
3C4-3FF	F1-FF	Not used

Hardware, BASIC, and DOS Interrupts

Vectors with Special Meanings

Interrupt 15--Cassette I/O: This vector points to the following functions:

- Device open
- Device closed
- Program termination
- Event wait

- Joystick support
- System Request key pressed
- Wait
- Move block
- Extended memory size determination
- Processor to protected mode

Additional information about these functions may be found in the BIOS listing.

Interrupt 1B--Keyboard Break Address: This vector points to the code that will be executed when the Ctrl and Break keys are pressed on the keyboard. The vector is invoked while responding to keyboard interrupt, and control should be returned through an IRET instruction. The power-on routines initialize this vector to point to an IRET instruction so that nothing will occur when the Ctrl and Break keys are pressed unless the application program sets a different value.

Control may be retained by this routine with the following problems:

- The Break may have occurred during interrupt processing, so that one or more End of Interrupt commands must be sent to the 8259 controller.
- All I/O devices should be reset in case an operation was underway at the same time.

Interrupt 1C--Timer Tick: This vector points to the code that will be executed at every system-clock tick. This vector is invoked while responding to the timer interrupt, and control should be returned through an IRET instruction. The power-on routines initialize this vector to point to an IRET instruction, so that nothing will occur unless the application modifies the pointer. The application must save and restore all registers that will be modified.

Interrupt 1D--Video Parameters: This vector points to a data region containing the parameters required for the initialization of the 6845 on the video adapter. Notice that there are four separate tables, and all four must be reproduced if all modes of operation are to be supported. The power-on routines initialize this vector to point to the parameters contained in the ROM video routines.

Interrupt 1E--Diskette Parameters: This vector points to a data region containing the parameters required for the diskette drive. The power-on routines initialize this vector to point to the parameters contained in the ROM diskette routine. These default parameters represent the specified values for any IBM drives attached to the system. Changing this parameter block may be necessary to reflect the specifications of other drives attached.

Interrupt 1F--Graphics Character Extensions: When operating in graphics modes 320 x 200 or 640 x 200, the read/write character interface will form a character from the ASCII code point, using a set of dot patterns. ROM contains the dot patterns for the first 128 code points. For access to the second 128 code points, this vector must be established to point at a table of up to 1Kb, where each code point is represented by 8 bytes of graphic information. At power-on time, this vector is initialized to 000:0, and the user must change this vector if the additional code points are required.

Interrupt 40--Reserved: When an IBM Personal Computer AT Fixed Disk and Diskette Drive Adapter is installed, the BIOS routines use interrupt 40 to revector the diskette pointer.

Interrupt 41 and 46: These vectors point to the parameters for the fixed disk drives, 41 for the first drive and 46 for the second. The power on routines initialize the vectors to point to the appropriate parameters in the ROM disk routine if CMOS is valid. The drive type codes in CMOS are used to select which parameter set the vector points to. Changing this parameter hook may be necessary to reflect the specifications of other fixed drives attached.

Other Read/Write Memory Usage

The IBM BIOS routines use 256 bytes of memory from absolute hex 400 to hex 4FF. Locations hex 400 to 407 contain the base addresses of any RS-232C adapters attached to the system. Locations hex 408 to 40F contain the base addresses of the printer adapter.

Memory locations hex 300 to hex 3FF are used as a stack area during the power-on initialization and bootstrap, when control is passed to it from power-on. If the user desires the stack to be in a different area, that area must be set by the application.

The following figure shows the reserved memory locations.

Address	Mode	Function
400-4A1 4A2-4EF 4F0-4FF	ROM BIOS	See BIOS listing Reserved Reserved as intra-application communication area for any application
500-5FF 500	DOS	Reserved for DOS and BASIC Print screen status flag store 0=Print screen not active or successful print screen operation 1=Print screen in progress 255=Error encountered during print screen operation
504	DOS	Single drive mode status byte
510-511	BASIC	BASIC's segment address store
512-515	BASIC	Clock interrupt vector segment: offset store
516-519	BASIC	Break key interrupt vector segment: offset store
51A-51D	BASIC	Disk error interrupt vector segment: offset store

Reserved Memory Locations

If you do a DEF SEG (default workspace segment):

Offset	Length	
2E	2	Line number of current line being executed
347	2	Line number of last error
30	2	Offset into segment of start of program text
358	2	Offset into segment of start of variables (end of program text 1-1)
6A	1	Keyboard buffer contents 0=No characters in buffer 1=Characters in buffer
4E	1	Character color in graphics mode*

BASIC Workspace Variables

*Set to 1,2, or 3 to get text in colors 1-3. Do not set to 0. The default is 3.

Example

```
100 PRINT PEEK (&H2E) + 256 x PEEK (&H2F)
```

L	H
Hex 64	Hex 00

The following is a BIOS memory map.

Starting Address	
00000	BIOS interrupt vectors
001E0	Available interrupt vectors
00400	BIOS data area
00500	User read/write memory
E0000	Read only memory
F0000	BIOS program area

BIOS Memory Map

BIOS Programming Hints

The BIOS code is invoked through program interrupts. The programmer should not "hard code" BIOS addresses into applications. The internal workings and absolute addresses within BIOS are subject to change without notice.

If an error is reported by the disk or diskette code, you should reset the drive adapter and retry the operation. A specified number of retries should be required for diskette reads to ensure that the problem is not due to motor startup.

When altering I/O-port bit values, the programmer should change only those bits necessary to the current task. Upon completion, the programmer should restore the original environment. Failure to adhere to this practice may cause incompatibility with present and future applications.

Additional information for BIOS programming can be found in Section 9 of this manual.

Adapters with System-Accessible ROM Modules

The ROM BIOS provides a way to integrate adapters with on-board ROM code into the system. During POST, interrupt vectors are established for the BIOS calls. After the default vectors are in place, a scan for additional ROM modules occurs. At this point, a ROM routine on an adapter may gain control and establish or intercept interrupt vectors to hook themselves into the system.

The absolute addresses hex C8000 through E0000 are scanned in 2K blocks in search of a valid adapter ROM. A valid ROM is defined as follows:

Byte 0 Hex 55

Byte 1 Hex AA

Byte 2 A length indicator representing the number of 512-byte blocks in the ROM.

Byte 3 Entry via a CALL FAR

A checksum is also done to test the integrity of the ROM module. Each byte in the defined ROM module is summed modulo hex 100. This sum must be 0 for the module to be valid.

When the POST identifies a valid ROM, it does a far call to byte 3 of the ROM, which should be executable code. The adapter may now perform its power-on initialization tasks. The adapter's ROM should now return control to the BIOS routines by executing a far return.

System Board Additional ROM Modules

The POST provides a way to integrate additional ROM modules' code into the system. These modules are placed in the sockets marked U17 and U37 if they are empty. A test for additional ROM modules on the system board occurs. At this point, the additional ROM, if valid, will gain control.

The absolute addresses hex E0000 through EFFFF are scanned in a 64K block in search of a valid checksum. Valid ROM is defined as follows:

- Byte 0** Hex 55
- Byte 1** Hex AA
- Byte 2** Not used
- Byte 3** Entry via a CALL FAR

A checksum is done to test the integrity of the ROM modules. Each byte in the ROM modules is summed modulo hex 100. This sum must be 0 for the modules to be valid. This checksum is located at address hex EFFFF.

When the POST identifies a valid ROM at this segment, it does a far call to byte 3 of the ROM, which should be executable code.

Keyboard Encoding and Usage

Encoding

The keyboard routine provided by IBM in the ROM scan codes into what will be termed *Extended ASCII*

Extended ASCII encompasses one-byte character codes with possible values of 0 to 255, an extended code for certain extended keyboard functions, and functions handled within the keyboard routine or through interrupts.

Character Codes

The following character codes are passed through the BIOS keyboard routine to the system or application program. A -1 means the combination is suppressed in the keyboard routine. The codes are returned in the AL register. See Section 7 for the exact codes.

The following figure is a keyboard layout showing the key positions.



Key	Base Case	Upper Case	Ctrl	Alt
90	Esc	Esc	Esc	-1
2	1	!	-1	Note 1
3	2	@	Null(000) Note 1	Note 1
4	3	#	-1	Note 1
5	4	\$	-1	Note 1
6	5	%	-1	Note 1
7	6	^	RS(030)	Note 1
8	7	&	-1	Note 1
9	8	*	-1	Note 1
10	9	(-1	Note 1
11	0)	-1	Note 1
12	-	_	US(031)	Note 1
13	=	+	-1	Note 1
15	Backspace(008)	Backspace(008)	Del(127)	-1
16	→(009)	←(Note 1)	-1	-1
17	q	Q	DC1(017)	Note 1
18	w	W	ETB(023)	Note 1
19	e	E	ENQ(005)	Note 1
20	r	R	DC2(018)	Note 1
21	t	T	DC4(020)	Note 1
22	y	Y	EM(025)	Note 1
23	u	U	NAK(021)	Note 1
24	i	I	HT(009)	Note 1
25	o	O	SI(015)	Note 1
26	p	P	DLE(016)	Note 1
27	[{	Esc(027)	Note 1
28]	}	GS(029)	-1
43	CR	CR	LF(010)	-1
30 Ctrl	-1	-1	-1	-1
31	a	A	SOH(001)	Note 1
32	s	S	DC3(019)	Note 1
33	d	D	EOT(004)	Note 1
34	f	F	ACK(006)	Note 1
35	g	G	BEL(007)	Note 1
36	h	H	BS(008)	Note 1
37	j	J	LF(010)	Note 1
38	k	K	VT(011)	Note 1
39	l	L	FF(012)	Note 1
40	;	:	-1	-1
41	'	■	-1	-1
1	Ω	◦	-1	-1
44 Shift	-1	-1	-1	-1
14	\		FS(028)	-1
46	z	Z	SUB(026)	Note 1
47	x	X	CAN(024)	Note 1
48	c	C	ETX(003)	Note 1
49	v	V	SYN(022)	Note 1
50	b	B	STX(022)	Note 1

(Part 1 of 1).

Character Codes

Key	Base Case	Upper Case	Ctrl	Alt
51	n	N	SO(014)	Note 1
52	m	M	CR(013)	Note 1
53	,	<	-1	-1
54	.	>	-1	-1
55	/	?	-1	-1
57 Shift	-1	-1	-1	-1
106	*	Note 2	Note 1	-1
56 Alt	-1	-1	-1	-1
61	SP	SP	SP	SP
64 Caps	-1	-1	-1	-1
Lock				
Lock				
70	Nul(Note 1)	Nul(Note 1)	Nul(Note 1)	Nul(Note 1)
65	Nul(Note 1)	Nul(Note 1)	Nul(Note 1)	Nul(Note 1)
71	Nul(Note 1)	Nul(Note 1)	Nul(Note 1)	Nul(Note 1)
66	Nul(Note 1)	Nul(Note 1)	Nul(Note 1)	Nul(Note 1)
72	Nul(Note 1)	Nul(Note 1)	Nul(Note 1)	Nul(Note 1)
67	Nul(Note 1)	Nul(Note 1)	Nul(Note 1)	Nul(Note 1)
73	Nul(Note 1)	Nul(Note 1)	Nul(Note 1)	Nul(Note 1)
68	Nul(Note 1)	Nul(Note 1)	Nul(Note 1)	Nul(Note 1)
74	Nul(Note 1)	Nul(Note 1)	Nul(Note 1)	Nul(Note 1)
69	Nul(Note 1)	Nul(Note 1)	Nul(Note 1)	Nul(Note 1)
95 Num	-1	-1	Pause(Note 2)	-1
Lock				
100	-1	-1	Break(Note 2)	-1
Scroll				
Lock				
Notes:				
1. Refer to Extended Codes in this section.				
2. Refer to Special Handling in this section.				

(Part 2 of 2)

Character Codes

The following figure lists keys that have meaning only in Num Lock, Shift, or Ctrl states. Notice that the Shift key temporarily reverses the current Num Lock state.

Key	Num Lock	Base Case	Alt	Ctrl
91	7	Home(Note 1)	-1	Clear Screen
96	8	↑(Note 1)	-1	-1
101	9	Page Up(Note 1)	-1	Top of Text and Home
107	-	-	-1	-1
92	4	←(Note 1)	-1	Reverse Word(Note 1)
97	5	-1	-1	-1
102	6	→(Note 1)	-1	Advance Word(Note 1)
108	+	+Note 1)	-1	-1
94	1	End(Note 1)	-1	Erase to EOL(Note 1)
98	2	↓(Note 1)	-1	-1
102	3	Page Down(Note 1)	-1	Erase to EOS(Note 1)
99	0	Ins	-1	-1
104	.	Del(Notes 1,2)	Note 2	Note 2

Notes:
Refer to Extended Codes in this section.
Refer to Special Handling in this section

Special Character Codes

Extended Codes

Extended Functions

For certain functions that cannot be represented by the standard ASCII code, an extended code is used. A character code of 000 (null) is returned in AL. This indicates that the system or application program should examine a second code, which will indicate the actual function. Usually, but not always, this second code is the scan code of the primary key that was pressed. This code is returned in AH.

Second Code	Function
3	Nul Character
15	→
16-25	Alt Q, W, E, R, T, Y, U, I, O, P
30-38	Alt A, S, D, F, G, H, J, K, L
44-50	Alt Z, X, C, V, B, N, M
59-68	F1 to F10 Function keys base case
71	↑ Home
72	↑
73	Page Up and Home Cursor
75	←
77	→
79	↓ End
80	↓
81	Page Down and Home Cursor
82	Ins(insert)
83	Del(delete)
84-93	F11 to F20(uppercase F1 to F10)
94-103	F21 to F30(Ctrl F1 to F10)
104-113	F31 to F40(Alt F1 to F10)
114	Ctrl PrtSc(start/stop echo to printer)
115	Ctrl ←(reverse word)
116	Ctrl →(advance word)
117	Ctrl End(erase to end of line-EOL)
118	Ctrl PgDn(erase to end of screen-EOS)
119	Ctrl Home(clear screen and home)
120-131	Alt 1, 2, 3, 4, 5, 6, 7, 8, 9, 0, -, = keys 2-13
132	Ctrl PgUp(top 25 lines of text and home cursor)

Keyboard Extended Functions

Shift States

Most shift states are handled within the keyboard routine, and are not apparent to the system or application program. In any case, the current status of active shift states is available by calling an entry point in the ROM keyboard routine. The following keys result in altered shift states:

Shift: This key temporarily shifts keys 1-14, 16-28, 31-41, 46-55, 106, and 65-74 to uppercase (base case if in Caps lock state). Also, the Shift temporarily reverses the Num Lock or non-Num Lock state of keys 91-93, 96, 98, and 101-103.

Ctrl: This key temporarily shifts keys 3, 7, 13, 15, 17-28, 31-39, 46-52, 106, 65-74, 42, 101, 92, 102, 91, 93, 95, 100, and 103 to the Ctrl state. The Ctrl key is also used with the Alt and Del keys to cause the system-reset function; with the Scroll Lock key to cause the break function; and with the Num Lock key to cause the pause function. The system-reset, break, and pause functions are described under "Special Handling" later in this section.

Alt: This key temporarily shifts keys 1-13, 17-26, 31-39, 46-52, and 65-74 to the Alt state. The Alt key is also used with the Ctrl and Del keys to cause the system reset function.

The Alt key also allows the user to enter any character code from 0-255 into the system from the keyboard. The user holds down the Alt key and types the decimal value of the characters desired on the numeric keypad (keys 91-93, 96-98, and 101-103). The Alt key is then released. If more than three digits are typed, a modulo-256 result is created. These three digits are interpreted as a character code and are sent through the keyboard routine to the system or application program. Alt is handled internal to the keyboard routine.

Break: The combination of the Ctrl and Break keys results in the keyboard routine signaling interrupt hex 1A. The extended characters AL=hex 00, AH=hex 00 are also returned.

Pause: The combination of the Ctrl and Num Lock keys causes the keyboard interrupt routine to loop, waiting for any key except Num Lock to be pressed. This provides a system- or application-transparent method of temporarily suspending list, print, etc. and then resuming the operation. The key used to resume operation is thrown away. Pause is handled internal to the keyboard routine.

Print Screen: The combination of the Shift and PrtSc keys results in an interrupt invoking the print screen routine. This routine works in the alphanumeric or graphics mode, with unrecognizable characters printing as blanks.

Caps Lock: This key shifts keys 17-26, 31-39, and 46-52 to uppercase. When Caps Lock is pressed again, it reverses the action. Caps Lock is handled internal to the keyboard routine.

When Caps Lock is pressed, it toggles the Caps Lock Mode indicator. If the indicator was on, it will go off; and if it was off, it will go on.

Scroll Lock: This key is interpreted by appropriate application programs as indicating that the use of cursor control keys should cause windowing over the text rather than cursor movement. When the Scroll Lock key is pressed again, it reverses the action. The keyboard routine simply records the current shift state of the Scroll Lock key. It is the responsibility of the application program to perform the function. When Scroll Lock is pressed, it toggles the Scroll Lock Mode indicator. If the indicator was on, it will go off; and if it was off, it will go on.

Num Lock: This key shifts keys 90-93 and 95-104 to upper case. When Num Lock is pressed again, it reverses the action. Num Lock is handled internal to the keyboard routine. When Num Lock is pressed, it toggles the Num Lock Mode indicator. If the indicator was on, it will go off; if it was off, it will go on.

Shift Key Priorities and Combinations: If combinations of the Alt, Ctrl, and Shift keys are pressed and only one is valid, the priority is as follows: the Alt key is first, the Ctrl key is second, and the Shift key is third. The only valid combination is Alt and Ctrl, which is used in the system-reset function.

Sys Req

When the Sys key is pressed, a hex 8500 is placed in AX, and an interrupt 15 is executed. When the Sys key is released, a hex 8501 is placed in AX, and another interrupt 15 is executed. If an application is to use the Sys key, the following rules must be observed:

Save the previous address

Overlay interrupt vector hex 15

Check AH for a value of hex 85

If yes, process may begin

If no, go to previous address

It is the responsibility of the application to preserve the value in all registers, except AX, upon return. Sys is handled internal to the keyboard routine.

Other Characteristics

The keyboard routine does its own buffering, and the keyboard buffer is large enough to support entries by a fast typist.

However, if a key is pressed when the buffer is full, the key will be ignored and the "alarm" will sound.

The keyboard routine also suppresses the typematic action of the following keys: Ctrl, Shift, Alt, Num Lock, Scroll Lock, Caps Lock, and Ins.

Special Handling

System Reset

The combination of the Alt, Ctrl, and Del keys results in the keyboard routine that starts a system reset or reboot. System reset is handled by BIOS.

Notes:



Warning: No STACK segment

Start Stop Length Name
00000H 0FFFEH FFFFH CODE

Origin Group
Address Publics by Name

0000:E729 A1
0000:3792 ACT_DISP_PAGE
0000:E137 ADERR
0000:E11C ADERR1
0000:17AA BEEP
0000:0000 BEGIN
0000:16B9 BLINK_INT
0000:E372 BOOT_INVA
0000:E6F2 BOOT_STRAP
0000:1B66 BOOT_STRAP_1
0000:E05E C1
0000:0222 C11
0000:E060 C2
0000:0C3F C21
0000:0454 C30
0000:0405 C8042
0000:E062 C8042A
0000:E066 C8042B
0000:E068 C8042C
0000:F859 CASSETTE_IO
0000:3FE2 CASSETTE_IO_1
0000:09FB CHK_VIDEO
0000:E234 CM1
0000:E25D CM2
0000:E286 CM3
0000:E0D0 CM4
0000:E2C6 CM4_A
0000:E2DF CM4_B
0000:E2F8 CM4_C
0000:E311 CM4_D
0000:FA6E CRT_CHAR_GEN
0000:E164 D1
0000:1805 D11
0000:E174 D2
0000:E184 D2A
0000:17FD DDS
0000:EC59 DISKETTE_IO
0000:20A5 DISKETTE_IO_1
0000:EFC7 DISK_BASE
0000:EF57 DISK_INT
0000:260E DISK_INT_1
0000:2A71 DISK_IO
0000:28DA DISK_SETUP
0000:2816 DSKETTE_SETUP
0000:FF53 DUMMY_RETURN
0000:1851 DUMMY_RETURN_1
0000:E06C EO
0000:E085 EO_A
0000:E09E EO_B
0000:E0E9 E1
0000:E32A E1_A
0000:E0FC E1_B
0000:E10C E1_C
0000:03E5 E30B
0000:03EB E30C
0000:F84D EQUIPMENT
0000:3E6C EQUIPMENT_1
0000:177A ERR_BEEP
0000:187F EXC_00
0000:1884 EXC_01
0000:1889 EXC_02
0000:188E EXC_03
0000:1893 EXC_04
0000:1898 EXC_05
0000:18B1 EXC_06
0000:18B6 EXC_07
0000:18BB EXC_08
0000:18C0 EXC_09
0000:18C5 EXC_10
0000:18CA EXC_11
0000:18CF EXC_12
0000:18D4 EXC_13
0000:18D9 EXC_14
0000:18DE EXC_15
0000:18E3 EXC_16
0000:18E8 EXC_17
0000:18ED EXC_18
0000:18F2 EXC_19

0000:18F7 EXC_20
0000:18FC EXC_21
0000:1901 EXC_22
0000:1906 EXC_23
0000:190B EXC_24
0000:1910 EXC_25
0000:1915 EXC_26
0000:191A EXC_27
0000:191F EXC_28
0000:1924 EXC_29
0000:1929 EXC_30
0000:192E EXC_31
0000:1753 E_MSG
0000:E1C2 F1
0000:E393 F1780
0000:E3A8 F1781
0000:E3BD F1782
0000:E3DB F1790
0000:E3EE F1791
0000:E1FB F1_A
0000:E34E F1_B
0000:E21F F3
0000:E152 F3A
0000:E15D F3B
0000:E18B F3D
0000:E1A1 F3D1
0000:E2AC F4
0000:E2B2 F4E
0000:E401 FD_TBL
0000:4752 FILL
0000:4392 GATE_A20
0000:1FF0 GDT_BLD
0000:1BC6 H5
0000:2FA4 HD_INT
0000:1852 INT_287
0000:E8E1 K10
0000:E91B K11
0000:E955 K12
0000:E95F K13
0000:E969 K14
0000:E976 K15
0000:30A9 K16
0000:E87E K6
0000:0008 Abs K6L
0000:E886 K7
0000:E88E K8
0000:E8C8 K9
0000:17D2 KBD_RESET
0000:E987 KB_INT
0000:3054 KB_INT_1
0000:E82E KEYBOARD_IO
0000:2FC8 KEYBOARD_IO_1
0000:E1D7 LOCK
0000:0010 Abs M4
0000:FOE4 M5
0000:FOEC M6
0000:FOF4 M7
0000:F841 MEMORY_SIZE_DETERMINE
0000:3E62 MEMORY_SIZE_DETERMINE_1
0000:E2C3 NMI_INT
0000:3E76 NMI_INT_1
0000:0411 OBF_42
0000:E064 OBF_42A
0000:E06A OBF_42B
0000:002C POST1
0000:0C3F POST2
0000:16AD POST3
0000:1753 POST4
0000:187F POST5
0000:199C POST6
0000:1C2D POST7
0000:EFD2 PRINTER_IO
0000:346F PRINTER_IO_1
0000:FF54 PRINT_SCREEN
0000:46CC PRINT_SCREEN_1
0000:174C PROC_SHUTDOWN
0000:1720 PROT_PRT_HEX
0000:1719 PRT_HEX
0000:186A PRT_SEG
0000:176C P_MSG
0000:FFF0 P_O_R
0000:38F5 READ_AC_CURRENT
0000:377B READ_CURSOR
0000:3A3B READ_DOT
0000:3DBC READ_LPEN
0000:1861 RE_DIRECT

```

0000:16D0 ROM_CHECK
0000:1AF9 ROM_ERR
0000:16AD ROS_CHECKSUM
0000:E739 RS232_IO
0000:34F5 RS232_IO_1
0000:462A RTC_INT
0000:38A3 SCROLL_DOWN
0000:37FF SCROLL_UP
0000:24C1 SEEK
0000:37B6 SET_COLOR
0000:3751 SET_CPOS
0000:372A SET_CTYPE
0000:364E SET_MODE
0000:3F2F SET_TOD
0000:1197 SHUT2
0000:114A SHUT3
0000:169B SHUT4
0000:118C SHUT6
0000:119A SHUT7
0000:4252 SHUT9
0000:1FF9 SIDT_BLD
0000:FF23 SLAVE_VECTOR_TABLE
0000:E05B START
0000:00A6 START_1
0000:199C STGTST_CNT
0000:1F1A SYSINIT1
0000:1933 SYS_32
0000:1938 SYS_33
0000:193D SYS_34
0000:1942 SYS_35
0000:1947 SYS_36
0000:194C SYS_37
0000:1951 SYS_38
0000:FEA5 TIMER_INT
0000:4684 TIMER_INT_1
0000:FE6E TIME_OF_DAY
0000:445C TIME_OF_DAY_1
0000:03C7 TST4_B
0000:03D3 TST4_C
0000:03F7 TST4_D
0000:FEF3 VECTOR_TABLE
0000:F065 VIDEO_IO
0000:3605 VIDEO_IO_1
0000:F0A4 VIDEO_PARMS
0000:37DC VIDEO_STATE
0000:E0B7 VIR_ERR
0000:393B WRITE_AC_CURRENT
0000:396E WRITE_C_CURRENT
0000:3A4C WRITE_DOT
0000:3D38 WRITE_TTY
0000:1713 XLAT_PR
0000:1B25 XMIT_8042
0000:1708 XPC_BYTE

```

```

0000:174C PROC_SHUTDOWN
0000:1753 POST4
0000:1753 E_MSG
0000:176C P_MSG
0000:177A ERR_BEEP
0000:17AA BEEP
0000:17D2 KBD_RESET
0000:17FD DDS
0000:1805 D11
0000:1851 DUMMY_RETURN_1
0000:1852 INT_287
0000:1861 RE_DIRECT
0000:186A PRT_SEG
0000:187F EXC_00
0000:187F POST5
0000:1884 EXC_01
0000:1889 EXC_02
0000:188E EXC_03
0000:1893 EXC_04
0000:1898 EXC_05
0000:18B1 EXC_06
0000:18B6 EXC_07
0000:18BB EXC_08
0000:18C0 EXC_09
0000:18C5 EXC_10
0000:18CA EXC_11
0000:18CF EXC_12
0000:18D4 EXC_13
0000:18D9 EXC_14
0000:18DE EXC_15
0000:18E3 EXC_16
0000:18E8 EXC_17
0000:18ED EXC_18
0000:18F2 EXC_19
0000:18F7 EXC_20
0000:18FC EXC_21
0000:1901 EXC_22
0000:1906 EXC_23
0000:190B EXC_24
0000:1910 EXC_25
0000:1915 EXC_26
0000:191A EXC_27
0000:191F EXC_28
0000:1924 EXC_29
0000:1929 EXC_30
0000:192E EXC_31
0000:1933 SYS_32
0000:1938 SYS_33
0000:193D SYS_34
0000:1942 SYS_35
0000:1947 SYS_36
0000:194C SYS_37
0000:1951 SYS_38
0000:199C POST6
0000:199C STGTST_CNT
0000:1AF9 ROM_ERR
0000:1B25 XMIT_8042
0000:1B66 BOOT_STRAP_1
0000:1BC6 H5
0000:1C2D POST7
0000:1F1A SYSINIT1
0000:1FF0 GDT_BLD
0000:1FF9 SIDT_BLD
0000:20A5 DISKETTE_IO_1
0000:24C1 SEEK
0000:260E DISK_INT_1
0000:2816 DISKETTE_SETUP
0000:28DA DISK_SETUP
0000:2A71 DISK_IO
0000:2FA4 HD_INT
0000:2FC8 KEYBOARD_IO_1
0000:3054 KB_INT_1
0000:30A9 K16
0000:346F PRINTER_IO_1
0000:34F5 RS232_IO_1
0000:3605 VIDEO_IO_1
0000:364E SET_MODE
0000:372A SET_CTYPE
0000:3751 SET_CPOS
0000:377B READ_CURSOR
0000:3792 ACT_DISP_PAGE
0000:37B6 SET_COLOR
0000:37DC VIDEO_STATE
0000:37FF SCROLL_UP
0000:38A3 SCROLL_DOWN
0000:38F5 READ_AC_CURRENT
0000:393B WRITE_AC_CURRENT

```

Address Publics by Value

```

0000:0000 BEGIN
0000:0008 Abs K6L
0000:0010 Abs M4
0000:002C POST1
0000:00A6 START_1
0000:0222 C11
0000:03C7 TST4_B
0000:03D3 TST4_C
0000:03E5 E30B
0000:03EB E30C
0000:03F7 TST4_D
0000:0405 C8042
0000:0411 OBF_42
0000:0454 C30
0000:09FB CHK_VIDEO
0000:0C3F POST2
0000:0C3F C21
0000:114A SHUT3
0000:1197 SHUT2
0000:119A SHUT7
0000:118C SHUT6
0000:169B SHUT4
0000:16AD ROS_CHECKSUM
0000:16AD POST3
0000:16B9 BLINK_INT
0000:16D0 ROM_CHECK
0000:1708 XPC_BYTE
0000:1713 XLAT_PR
0000:1719 PRT_HEX
0000:1720 PROT_PRT_HEX

```

0000:396E WRITE_C_CURRENT
 0000:3A3B READ_DOT
 0000:3A4C WRITE_DOT
 0000:3D38 WRITE_TTY
 0000:3DBC READ_LPEN
 0000:3E62 MEMORY_SIZE_DETERMINE_1
 0000:3E6C EQUIPMENT_1
 0000:3E76 NMI_INT_1
 0000:3F2F SET_TOD
 0000:3FE2 CASSETTE_IO_1
 0000:4252 SHUT9
 0000:4392 GATE_A20
 0000:445C TIME_OF_DAY_1
 0000:462A RTC_INT
 0000:4684 TIMER_INT_1
 0000:46CC PRINT_SCREEN_1
 0000:4752 FILL
 0000:E05B START
 0000:E05E C1
 0000:E060 C2
 0000:E062 C8042A
 0000:E064 OBF_42A
 0000:E066 C8042B
 0000:E068 C8042C
 0000:E06A OBF_42B
 0000:E06C EO
 0000:E085 EO_A
 0000:E09E EO_B
 0000:E0B7 VIR_ERR
 0000:E0D0 CM4
 0000:E0E9 E1
 0000:E0FC E1_B
 0000:E10C E1_C
 0000:E11C ADERR1
 0000:E137 ADERR
 0000:E152 F3A
 0000:E15D F3B
 0000:E164 D1
 0000:E174 D2
 0000:E184 D2A
 0000:E188 F3D
 0000:E1A1 F3D1
 0000:E1C2 F1
 0000:E1D7 LOCK
 0000:E1FB F1_A
 0000:E21F F3
 0000:E234 CM1
 0000:E25D CM2
 0000:E286 CM3
 0000:E2AC F4
 0000:E2B2 F4E
 0000:E2C3 NMI_INT
 0000:E2C6 CM4_A
 0000:E2DF CM4_B
 0000:E2F8 CM4_C
 0000:E311 CM4_D
 0000:E32A E1_A
 0000:E34E F1_B
 0000:E372 BOOT_INVA
 0000:E393 F1780
 0000:E3A8 F1781
 0000:E3BD F1782
 0000:E3DB F1790
 0000:E3EE F1791
 0000:E401 FD_TBL
 0000:E6F2 BOOT_STRAP
 0000:E729 A1
 0000:E739 RS232_IO
 0000:E82E KEYBOARD_IO
 0000:E87E K6
 0000:E886 K7
 0000:E88E K8
 0000:E8C8 K9
 0000:E8E1 K10
 0000:E91B K11
 0000:E955 K12
 0000:E95F K13
 0000:E969 K14
 0000:E976 K15
 0000:E987 KB_INT
 0000:EC59 DISKETTE_IO
 0000:EF57 DISK_INT
 0000:EF7C DISK_BASE
 0000:EFD2 PRINTER_IO
 0000:F065 VIDEO_IO
 0000:F0A4 VIDEO_PARMS

0000:FOE4 M5
 0000:FOEC M6
 0000:FOF4 M7
 0000:F841 MEMORY_SIZE_DETERMINE
 0000:F84D EQUIPMENT
 0000:F859 CASSETTE_IO
 0000:FA6E CRT_CHAR_GEN
 0000:FE6E TIME_OF_DAY
 0000:FEA5 TIMER_INT
 0000:FEF3 VECTOR_TABLE
 0000:FF23 SLAVE_VECTOR_TABLE
 0000:FF53 DUMMY_RETURN
 0000:FF54 PRINT_SCREEN
 0000:FFFO P_OR



BIOS I/O INTERFACE

THESE INTERFACE LISTINGS, PROVIDE ACCESS TO BIOS ROUTINES
 THESE BIOS ROUTINES ARE MEANT TO BE ACCESSED THROUGH
 SOFTWARE INTERRUPTS ONLY. ANY ADDRESSES PRESENT IN
 THE LISTINGS ARE INCLUDED ONLY FOR COMPLETENESS,
 NOT FOR REFERENCE. APPLICATIONS WHICH REFERENCE
 ABSOLUTE ADDRESSES WITHIN THE CODE SEGMENT
 VIOLATE THE STRUCTURE AND DESIGN OF BIOS.

PAGE

```

-----
MODULES REQUIRED
DATA.SRC      --> DATA AREA
TEST1.SRC     --> TEST.01 THRU TEST.16
TEST2.SRC     --> TEST.17 THRU TEST.22
TEST3.SRC     --> PROCEDURES
                ROS_CHECKSUM
                BLNK_INT
                ROM_CHECK
                XPC_BYTE
                PRT_HEX
                PROT_PRT_HEX
                PROC_SHUTDOWN
                E_MSG
                P_MSG
                BEEP
                ERR_BEEP
                KBD_RESET
                D11_DUMMY INT HANDLER
                INT13 - X287 HANDLER
                PRT_SEG
                DDS
                HARDWARE INT 9 HANDLER (TYPE 71)
TEST4.SRC     --> EXCEPTION INTERRUPTS
                STGST_CNT
                ROM_ERR
                XMIT_8042
                BOOT_STRAP
TEST5.SRC     --> PROTECTED MODE TEST
TEST6.SRC     --> BUILD PROTECTED MODE DESCRIPTORS
TEST7.SRC     --> DISKETTE BIOS
SYSINI1.SRC   --> HARD FILE BIOS
GDT_BLD.SRC   --> KEYBOARD BIOS
SIDT_BLD.SRC  --> PRINTER BIOS
DSKETE.SRC    --> RS232 BIOS
DISK.SRC      --> VIDEO BIOS
KYBD.SRC      --> MEM_SIZE
PRT.SRC       --> EQUIP_DET
RS232.SRC    --> NMI
VIDEO1.SRC    --> SET TOD
BIOS.SRC      --> DUMMY CASSETTE (INT 15)
                DEVICE OPEN
                DEVICE CLOSE
                PROGRAM TERMINATION
                EVENT WAIT
                JOYSTICK SUPPORT
                SYSTEM REQUEST KEY
                WAIT
                MOVE BLOCK
                EXTENDED MEMORY SIZE DETERMINE
                PROCESSOR TO VIRTUAL MODE
BIOS1.SRC     --> TIME OF DAY
                TRIMER INT
                PRINT_SCREEN
BIOS2.SRC     --> PC COMPATIBILITY AND TABLES
                POST ERROR MESSAGES
ORGS.SRC      -->
-----

```

INCLUDE POSTEQU.SRC

EQUATES

```

-----
C TEST EQU 0 ; CONDITIONAL ASM (TEST2.SRC)
C KEY_LOCK EQU 0 ; CONDITIONAL ASM (TEST2.SRC)
C KEY_NUMS EQU 0 ; CONDITIONAL ASM (KYBD.SRC)
-----
C X287 EQU 0F0H ; MATH PROCESSOR
-----
C LOOP_POST EQU 020H ; MFG LOOP POST JUMPER
-----
C REFRESH_BIT EQU 010H ; REFRESH TEST BIT
-----
C POST_SS EQU 0H ; POST STACK SEGMENT
C POST_SP EQU 8000H ; POST STACK POINTER
C TEMP_STACK_LO EQU 0FFFFH ;
C TEMP_STACK_HI EQU 0 ; SET PROTECTED MODE TEMP_SS
                0:FFFFH
-----
C PORT_A EQU 60H ; 8042 KEYBOARD SCAN/DIAG OUTPUTS
C PORT_B EQU 61H ; 8042 READ WRITE REGISTER
C PARITY_ERR EQU 0C0H ; RAM/IO CHANNEL PARITY ERROR
C RAM_PAR_ON EQU 11110011B ; AND THIS VALUE
C RAM_PAR_OFF EQU 00001100B ; OR THIS VALUE
C IO_CHK EQU 01000000B ; IO CHECK?
C PRTY_CHK EQU 10000000B ; PARITY CHECK?
-----
C STATUS_PORT EQU 64H ; 8042 STATUS PORT
C OUT_BUF_FULL EQU 01H ; 0 = +OUTPUT BUFFER FULL
C INPT_BUF_FULL EQU 02H ; 1 = +INPUT BUFFER FULL
C SYS_FLAG EQU 04H ; 2 = -SYSTEM FLAG -POR/-SELF TEST
C CMD_DATA EQU 08H ; 3 = -COMMAND+DATA
C KYBD_INH EQU 10H ; 4 = +KEYBOARD INHIBITED
C TRANS_TMOU EQU 20H ; 5 = +TRANSMIT TIMEOUT
C RCV_TROUT EQU 40H ; 6 = +RECEIVE TIME OUT
C PARITY_EVEN EQU 80H ; 7 = +PARITY IS EVEN
C SHUT_CMD EQU 0FEH ; CAUSE A SHUTDOWN COMMAND
C INTR_FACE_CK EQU 0ABH ; CHECK 8042 INTERFACE CMD
C KYBD_CLK_DATA EQU 0E0H ; GET KYBD CLOCK AND DATA CMD
C KYBD_CLK EQU 0011H ; KEYBOARD CLOCK BIT 0
-----
C -----MANUFACTURING PORT-----
C MFG_PORT EQU 80H ; MANUFACTURING CHECKPOINT PORT
C -----MANUFACTURING BIT DEFINITION FOR MFG_ERR_FLAG+1-----
C MEM_FAIL EQU 00000001B ; STORAGE TEST FAILED (ERROR 20X)
C PRO_FAIL EQU 00000010B ; VIRTUAL MODE TEST FAILED (ERROR 104)
C LMS_FAIL EQU 00000100B ; LOW MEG CHIP SELECT FAILED (ERROR 109)
C KYCLK_FAIL EQU 00001000B ; KEYBOARD CLOCK TEST FAILED (ERROR 304)
C KY_SYSV_FAIL EQU 00010000B ; KEYBOARD OR SYSTEM TEST FAILED (ERROR 303)
C KYBD_FAIL EQU 00100000B ; KEYBOARD FAILED (ERROR 301)
C DSK_FAIL EQU 01000000B ; DISKETTE TEST FAILED (ERROR 601)
-----

```

```

= 0080 C KEY_FAIL EQU 1000000B ; KEYBOARD LOCKED (ERROR 302)
= 0010 C :-----8042 INPUT PORT BIT DEFINITION-----
= 0020 C C BASE_RAM EQU 10H ;BASE R/W MEMORY
= 0040 C C MFG JMP EQU 20H ;LEAD POST JUMPER
= 0080 C C DSP JMP EQU 40H ;DISPLAY TYPE JUMPER
C C KEY_BD_INHIB EQU 80H ;KEYBOARD INHIBIT SWITCH
= 0010 C :-----8042 RAM DEFINITION-----
C C INH_KEYBOARD EQU 10H ;BYTE 0 BIT 4 OF 8042 RAM
C :-----COMMANDS-----
= 0020 C C READ_8042_RAM EQU 20H ;BITS 0-4 = ADDRESS (20-3F)
= 0060 C C WRITE_8042_RAM EQU 60H ;
= 00AA C C SELF_8042_TEST EQU 0AAH ; 8042 SELF TEST
= 00C0 C C READ_8042_INPUT EQU 0C0H ; READ 8042 INPUT PORT
= 00AE C C ENA_RBD EQU 0AEH ; ENABLE KEYBOARD COMMAND
= 00AD C C DIS_KBD EQU 0ADH ; DISABLE KEYBOARD COMMAND
= 00DF C C ENABLE_BIT20 EQU 0DFH ; ENABLE ADDR LINE BIT 20
= 00DD C C DISABLE_BIT20 EQU 0DDH ; DISABLE ADDR LINE BIT 20
C :-----KEYBOARD LED COMMANDS-----
= 00F1 C C KB_MENU EQU 0F1H ; SELECT MENU COMMAND
= 00F4 C C KB_ENABLE EQU 0F4H ; KEYBOARD ENABLE
= 00F7 C C KB_MAKE_BREAK EQU 0F7H ; TYPAMATIC
= 00FE C C KB_ECHO EQU 0FEH ; ECHO COMMAND
= 00FF C C KB_RESET EQU 0FFH ; SELF DIAGNOSTIC COMMAND
= 00ED C C LED_CMD EQU 0EDH ; LED WRITE COMMAND
C :-----KEYBOARD RESPONSE-----
= 00AA C C Kb_OK EQU 0AAH ; RESPONSE FROM SELF DIAG
= 00FA C C Kb_ACK EQU 0FAH ; ACKNOWLEDGE FROM TRANSMISSION
= 00FF C C KB_OVER_RUN EQU 0FFH ; OVER RUN
= 00A4 C C KB_RESEND EQU 0A4H ; RESEND REQUEST
= 00F0 C C KB_BREAK EQU 0F0H ; KEYBOARD BREAK CODE
= 0010 C C KB_FA EQU 010H ; ACK RECEIVED
= 0020 C C KB_FE EQU 020H ; RESEND RECEIVED FLAG
= 0040 C C KB_PR_LED EQU 040H ; MODE INDICATOR UPDATE
C :-----CMOS EQUATES-----
= 0070 C C CMOS_PORT EQU 070H ; I/O ADDRESS OF CMOS PORT
= 008A C C CLK_UP EQU 08AH ; CLOCK UPDATE STATUS
= 008B C C CMOS_ALARM EQU 08BH ;
= 0090 C C CMOS_BEGIN EQU 090H ;
= 00AD C C CMOS_END EQU 0ADH ;
= 00AF C C SHUT_DOWN EQU 0AFH ; SHUTDOWN OFFSET
= 008D C C BATTERY_COND_STATUS EQU 08DH ; BATTERY STATUS
= 0081 C C M_SIZE_HI EQU 081H ; I/O MEMORY SIZE HIGH BYTE (POST)
= 0080 C C M_SIZE_LO EQU 080H ; I/O MEMORY SIZE LOW BYTE (POST)
= 0096 C C MT_SIZE_HI EQU 096H ; 0->640K CONFIG MEMORY SIZE (SETUP)
= 0095 C C M1_SIZE_LO EQU 095H ; LOW BYTE (SETUP)
= 0098 C C M2_SIZE_HI EQU 098H ; 640K->SUP CONFIG MEMORY SIZE (SETUP)
= 0097 C C M2_SIZE_LO EQU 097H ; LOW BYTE (SETUP)
= 0094 C C C_EQUIP EQU 094H ; CMOS EQUIPMENT FLAG
= 0092 C C HD_FILE_TYPE EQU 092H ; HARD FILE TYPE BYTE
C C PAGE EQU 093H ;
C :-----CMOS DIAG STATUS ERROR FLAGS-----
= 008E C C DIAG_STATUS EQU 08EH ; CMOS ADDRESS OF DIAG_STATUS
= 0080 C C BAD_BAT EQU 080H ; DEAD BATTERY
= 0040 C C BAD_CKSUM EQU 040H ; CHECKSUM ERROR
= 0020 C C BAD_CONFIG EQU 020H ; MINIMUM CONFIG USED INSTEAD OF CMOS
= 0010 C C W_MEM_SIZE EQU 010H ; MEMORY SIZE NOT EQUAL TO CONFIG
= 0008 C C HF_FAIL EQU 008H ; HARD FILE FAILURE ON INIT
= 0004 C C CMOS_CLK_FAIL EQU 004H ; CMOS CLK NOT UPDATING OR NOT VALID
C :-----CMOS INFORMATION FLAGS-----
= 0083 C C INFO_STATUS EQU 083H ; CMOS ADDRESS OF INFO BYTE
= 0080 C C MGROR EQU 080H ; 512K -> 640K CARD INSTALLED
= 0040 C C NEW_INST EQU 040H ; FLAG USED BY CMOS SETUP UTILITY
= 0020 C C HF_BOOT EQU 020H ; BOOT HARD FILE FLAG
C :-----INTERRUPT EQUATES-----
= 0020 C C INTA00 EQU 20H ; 8259 PORT
= 0021 C C INTA01 EQU 21H ; 8259 PORT
= 0020 C C EI EQU 20H ;
= 00A0 C C INTB00 EQU 0A0H ; 2ND 8259
= 00A1 C C INTB01 EQU 0A1H ;
= 0070 C C INT_TYPE EQU 070H ; START OF 8259 INTERRUPT TABLE LOCATION
= 0010 C C INT_VIDEO EQU 010H ; VIDEO VECTOR
C :-----TIMER-----
= 0040 C C TIMER EQU 401H ;
= 0013 C C TIM_CTL EQU 43H ; 8253 TIMER CONTROL PORT ADDR
= 0040 C C TIMER0 EQU 40H ; 8253 TIMER/CNTNR 0 PORT ADDR
= 0001 C C TIMINT EQU 01H ; TIMER 0 INTR RECV'D MASK
C :-----DMA-----
= 0008 C C DMA08 EQU 08H ; DMA STATUS REG PORT ADDR
= 0000 C C DMA EQU 00H ; DMA CH.0 ADDR. REG PORT ADDR
C :-----DMA1-----
= 00D0 C C DMA18 EQU 0D0H ; 2ND DMA STATUS PORT ADDR
= 00C0 C C DMA1 EQU 0C0H ; 2ND DMA CH.0 ADDR. REG PORT ADDR
C :-----DMA PAGE-----
= 0081 C C DMA_PAGE EQU 81H ; START OF DMA PAGE REGISTERS
= 008F C C LAST_DMA_PAGE EQU 8FH ; LAST DMA PAGE REGISTER
C :-----MAX/MIN PERIOD-----
= 0540 C C MAX_PERIOD EQU 540H ;
= 0410 C C MIN_PERIOD EQU 410H ;
= 0060 C C RBD_IN EQU 60H ; KEYBOARD DATA IN ADDR PORT
= 0002 C C RBDINT EQU 02H ; KEYBOARD INTR MASK
= 0060 C C KB_DATA EQU 60H ; KEYBOARD SCAN CODE PORT
= 0061 C C KB_CTL EQU 61H ; CONTROL BITS FOR KEYBOARD SENSE DATA
= 0080 C C KB_ERR EQU 80H ; KEYBOARD TRANSMIT ERROR FLAG
C :-----SHIFT FLAG EQUATES WITHIN KB_FLAG-----
= 0080 C C INS_STATE EQU 80H ; INSERT STATE IS ACTIVE
= 0040 C C CAPS_STATE EQU 40H ; CAPS LOCK STATE HAS BEEN TOGGLED
= 0020 C C NUM_STATE EQU 20H ; NUM LOCK STATE HAS BEEN TOGGLED
= 0010 C C SCROLL_STATE EQU 10H ; SCROLL LOCK STATE HAS BEEN TOGGLED
= 0008 C C ALT_SHIFT EQU 08H ; ALTERNATE SHIFT KEY DEPRESSED
= 0004 C C CTL_SHIFT EQU 04H ; CONTROL SHIFT KEY DEPRESSED
= 0002 C C LEFT_SHIFT EQU 02H ; LEFT SHIFT KEY DEPRESSED
= 0001 C C RIGHT_SHIFT EQU 01H ; RIGHT SHIFT KEY DEPRESSED
= 0080 C C INS_SHIFT EQU 80H ; INSERT KEY IS DEPRESSED
= 0040 C C CAPS_SHIFT EQU 40H ; CAPS LOCK KEY IS DEPRESSED
= 0020 C C NUM_SHIFT EQU 20H ; NUM LOCK KEY IS DEPRESSED
= 0010 C C SCROLL_SHIFT EQU 10H ; SCROLL LOCK KEY IS DEPRESSED
= 0008 C C HOLD_STATE EQU 08H ; SUSPEND KEY HAS BEEN TOGGLED
= 0005 C C SYS_SHIFT EQU 04H ; SYSTEM KEY DEPRESSED AND HELD
= 0045 C C NUM_KEY EQU 69 ; SCAN CODE FOR NUMBER LOCK
= 0046 C C SCROLL_KEY EQU 70 ; SCROLL LOCK KEY
= 0038 C C ALT_KEY EQU 56 ; ALTERNATE SHIFT KEY SCAN CODE
= 003D C C CTL_KEY EQU 29 ; SCAN CODE FOR CONTROL KEY
= 003A C C CAPS_KEY EQU 58 ; SCAN CODE FOR SHIFT LOCK
= 002A C C LEFT_KEY EQU 42 ; SCAN CODE FOR LEFT SHIFT
= 0036 C C RIGHT_KEY EQU 54 ; SCAN CODE FOR RIGHT SHIFT
= 0052 C C INS_KEY EQU 82 ; SCAN CODE FOR INSERT KEY
= 0053 C C DEL_KEY EQU 83 ; SCAN CODE FOR DELETE KEY
= 0054 C C SYS_KEY EQU 54H ; SCAN CODE FOR SYSTEM KEY
C :-----DISKETTE EQUATES-----
= 0080 C C INT_FLAG EQU 80H ; INTERRUPT OCCURRENCE FLAG
= 0025 C C MOTOR_WAIT EQU 37 ; 2 SECS OF COUNTS FOR MOTOR TURN OFF
= 0080 C C TIME_OUT EQU 80H ; ATTACHMENT FAILED TO RESPOND
= 0040 C C BAD_SEEK EQU 40H ; SEEK OPERATION FAILED
= 0020 C C BAD_NEC EQU 20H ; NEC CONTROLLER HAS FAILED
= 001D C C BAD_CRC EQU 1DH ; BAD CRC ON DISKETT READ
= 0009 C C DMA_BOUNDARY EQU 09H ; ATTEMPT TO DMA ACROSS 64K BOUNDARY

```

```

= 0008      C BAD_DMA EQU 08H ; DMA OVERRUN ON OPERATION
= 0006      C MEDIA_CHANGE EQU 06H ; MEDIA REMOVED ON DUAL ATTACH CARD
= 0004      C RECORD_NOT_FND EQU 04H ; REQUESTED SECTOR NOT FOUND
= 0003      C WRITE_PROTECT EQU 03H ; WRITE ATTEMPTED ON WRITE PROT DISK
= 0002      C BAD_ADDR_MARK EQU 02H ; ADDRESS MARK NOT FOUND
= 0001      C BAD_CMD EQU 01H ; BAD COMMAND PASSED TO DISKETTE I/O

= 0002      C XRATE EQU 02H ; 250KBS DATA TRANSFER RATE
= 0001      C DUAL EQU 01H ; DUAL ATTACH CARD PRESENT FLAG

= 0080      C DSK_CHG EQU 080H ; DISKETTE CHANGE FLAG MASK BIT
= 0007      C STATE_MSK EQU 007H ; USED TO STRIP OFF STATE OF MEDIA
= 0078      C REV_STATE EQU 078H ; USED AS MASK FOR STATE BITS
= 0010      C DETERMINED EQU 010H ; SET STATE DETERMINED IN STATE BITS
= 0003      C TRAM_MSK EQU 03H ; ISOLATE SHIFTED TRANSFER RATE BITS
= 0020      C DOUBLE_STEP EQU 020H ; MASK TO TURN ON DOUBLE STEPPING
= 00F0      C MOTOR_MSK EQU 0F0H ; MASK TO CLEAR MOTOR ON BITS
= 0002      C MAX_DRV EQU 002H ; MAX NUMBER OF DRIVES
= 0010      C HOME EQU 010H ; TRACK 0 MASK
= 0004      C SENSE_DRV_ST EQU 004H ; SENSE DRIVE STATUS COMMAND
= 0001      C ONE EQU 001H ; SEEK ONE TRACK
= 0030      C TRK_SLAP EQU 030H ; CRASH STOP (48 TPI DRIVES)
= 000A      C QUIET_SEEK EQU 00AH ; SEEK TO TRACK 10
= 000F      C HD12_SETTLE EQU 015D ; 1.2 M HEAD SETTLE TIME
= 0014      C HD320_SETTLE EQU 020D ; 320 K HEAD SETTLE TIME
= 0080      C WRITE_OP EQU 080H ; WRITE OPERATION FLAG

C PAGE
C ;----- DISK CHANGE LINE EQUATES
C NOCHGLN EQU 001H ; NO DISK CHANGE LINE AVAILABLE
C CHGLN EQU 002H ; DISK CHANGE LINE AVAILABLE
C ;----- MEDIA/DRIVE STATE INDICATORS
C M32GD126 EQU 093H ; STATE MACHINE - 320/360 MEDIA/DRIVE
C M32GD12 EQU 074H ; STATE MACHINE - 320/360 MEDIA, 1.2DRIVE
C M12D12 EQU 015H ; STATE MACHINE - 1.2 MEDIA/DRIVE
C POA_DUAL EQU 061H ; 300K DATA TRANSFER RATE & STATE 1
C POA_START EQU 080H ; 250K DATA TRANSFER RATE & STATE 0
C ;----- CMOS NON-VOLATILE RAM EQUATES
C CMOSDSB_ADDR EQU 00EH ; DISKETTE STATUS BYTE ADDRESS
C ADDR_PRT EQU 070H ; CMOS ADDRESS PORT ADDRESS
C CDATA_PRT EQU 071H ; CMOS DATA PORT ADDRESS
C CMOS_GOOD EQU 0C0H ; BATTERY AND CHECKSUM INDICATOR
C CMOSDSK_BYTE EQU 010H ; DISKETTE BYTE ADDRESS
C LOWN1B EQU 00FH ; ISOLATE LOW NIBBLE IN REGISTER MASK
C INVALID_DRV EQU 002H ; FIRST INVALID DISKETTE TYPE

C ;----- TIMER DATA AREA
C ;
C ; COUNTS_SEC EQU 18
C ; COUNTS_MIN EQU 1092
C ; COUNTS_HOUR EQU 65543
C ; COUNTS_DAY EQU 1573040 = 1800BH
C PAGE

C INCLUDE DSEG.SRC
C ;-----
C ; 0286 INTERRUPT LOCATIONS (READ):
C ;-----
C ABS0 SEGMENT AT 0
C STG_LOCO LABEL BYTE
C NMI_PTR ORG 2*4 LABEL WORD
C INT5_PTR ORG 5*4 LABEL WORD
C INT5_ORG ORG 8*4
C INT_ADDR LABEL WORD
C INT_PTR LABEL DWORD
C ;-----
C VIDEO_INT ORG 10H*4 LABEL WORD
C VIDEO_ORG ORG 13H*4 LABEL WORD ; NEW FDISK
C ORG_VECTOR LABEL DWORD
C BASIC_PTR ORG 18H*4 LABEL WORD
C ;-----
C BOOT_VEC LABEL DWORD
C BOOT_VECTOR LABEL DWORD
C PARM_PTR ORG 1DH*4 LABEL DWORD ; POINTER TO VIDEO PARMS
C ;-----
C DISK_PTR ORG 1EH*4 LABEL DWORD
C DISK_POINTER ORG 01FH*4 LABEL DWORD
C EXT_PTR LABEL DWORD
C DISK_VECTOR ORG 40H*4 LABEL DWORD ; DISKETTE POINTER
C ;-----
C LOW1B_ORG ORG 41H*4 LABEL DWORD
C HF_TBL_VEC ORG 46H*4 LABEL DWORD
C HF1_TBL_VEC ORG 70H*4 LABEL DWORD
C SLAVE_INT_PTR LABEL DWORD
C RTC_INT_VEC ORG 76H*4 LABEL DWORD ; REAL TIME CLOCK INT
C ;-----
C HDISK_INT LABEL DWORD ; FIXED DISK INTERRUPT VECTOR
C ;-----
C DATA_AREA ORG 400H LABEL BYTE ; ABSOLUTE LOCATION OF DATA SEGMENT
C DATA_WORD LABEL WORD
C MFG_TEST_ORG ORG 0500H LABEL FAR
C RTC_ORG ORG 7C00H LABEL FAR
C BOOT_LOCN LABEL FAR
C ABS0 ENDS
C PAGE
C ;-----
C ; STACK -- USED DURING INITIALIZATION ONLY
C ;-----
C STACK SEGMENT AT 30H
C DW 128 DUP(?)

0000
0000 80 [ ???? ]
]

0100
0100
C TOS LABEL WORD
C STACK ENDS
C ;-----
C ; ROM BIOS DATA AREAS
C ;-----
C DATA SEGMENT AT 40H
C DATA_BASE LABEL BYTE
C RS232_BASE DW 4 DUP(?) ; ADDRESSES OF RS232 ADAPTERS

0000
0000 04 [ ???? ]
]

0008 04 [ ???? ]
]

0010 01 [ ???? ]
]
EQUIP_FLAG DW 1 DUP(?) ; INSTALLED HARDWARE

```

```

C
0012 01 [ ?? ] MFG_TST DB 1 DUP(?) ; INITIALIZATION FLAG
C
0013 01 [ ???? ] MEMORY_SIZE DW 1 DUP(?) ; MEMORY SIZE IN K BYTES
C
0015 01 [ ?? ] MFG_ERR_FLAG DB 1 DUP(?) ; SCRATCHPAD FOR MANUFACTURING
C
0016 01 [ ?? ] DB 1 DUP(?) ; ERROR CODES
C
PAGE
;-----
; KEYBOARD DATA AREAS :
;-----
0017 01 [ ?? ] KB_FLAG DB 1 DUP(?)
C
0018 01 [ ?? ] KB_FLAG_1 DB 1 DUP(?) ; SECOND BYTE OF KEYBOARD STATUS
C
0019 01 [ ?? ] ALT_INPUT DB 1 DUP(?) ; STORAGE FOR ALTERNATE KEYPAD ENTRY
C
001A 01 [ ???? ] BUFFER_HEAD DW 1 DUP(?) ; POINTER TO HEAD OF KEYBOARD BUFFER
C
001C 01 [ ???? ] BUFFER_TAIL DW 1 DUP(?) ; POINTER TO TAIL OF KEYBOARD BUFFER
C
001E 10 [ ???? ] KB_BUFFER DW 16 DUP(?) ; ROOM FOR 15 ENTRIES
C
003E KB_BUFFER_END LABEL WORD
;----- HEAD = TAIL INDICATES THAT THE BUFFER IS EMPTY
;-----
; DISKETTE DATA AREAS :
;-----
003E 01 [ ?? ] SEEK_STATUS DB 1 DUP(?) ; DRIVE RECALIBRATION STATUS
C
003F 01 [ ?? ] MOTOR_STATUS DB 1 DUP(?)
; BIT 3-0 = DRIVE 3-0 NEEDS RECAL
; BEFORE NEXT SEEK IF BIT IS = 0
; MOTOR STATUS
C
; BIT 3-0 = DRIVE 3-0 IS CURRENTLY
; RUNNING
; BIT 7 = CURRENT OPERATION IS A WRITE,
; REQUIRES DELAY
; TIME OUT COUNTER FOR DRIVE TURN OFF
0040 01 [ ?? ] MOTOR_COUNT DB 1 DUP(?)
C
0041 01 [ ?? ] DISKETTE_STATUS DB 1 DUP(?) ; RETURN CODE STATUS BYTE
C
0042 0042 CMD_BLOCK LABEL BYTE
0042 07 [ ' ?' ] HD_ERROR LABEL BYTE
NEG_STATUS DB 7 DUP(?) ; STATUS BYTES FROM NEC
C
PAGE
;-----
; VIDEO DISPLAY DATA AREA :
;-----
0049 01 [ ?? ] CRT_MODE DB 1 DUP(?) ; CURRENT CRT MODE
C
004A 01 [ ???? ] CRT_COLS DW 1 DUP(?) ; NUMBER OF COLUMNS ON SCREEN
C
004C 01 [ ???? ] CRT_LEN DW 1 DUP(?) ; LENGTH OF REGEN IN BYTES
C
004E 01 [ ???? ] CRT_START DW 1 DUP(?) ; STARTING ADDRESS IN REGEN BUFFER
C
0050 08 [ ???? ] CURSOR_POSN DW 8 DUP(?) ; CURSOR FOR EACH OF UP TO 8 PAGES
C
0060 01 [ ???? ] CURSOR_MODE DW 1 DUP(?) ; CURRENT CURSOR MODE SETTING
C
0062 01 [ ?? ] ACTIVE_PAGE DB 1 DUP(?) ; CURRENT PAGE BEING DISPLAYED
C
0063 01 [ ???? ] ADDR_6845 DW 1 DUP(?) ; BASE ADDRESS FOR ACTIVE DISPLAY CARD
C
0065 01 [ ?? ] CRT_MODE_SET DB 1 DUP(?) ; CURRENT SETTING OF THE 3X8 REGISTER
C
0066 01 [ ?? ] CRT_PALLETTE DB 1 DUP(?) ; CURRENT PALLETTE SETTING COLOR CARD
C
PAGE

```

```

0067 01 [  ???? ]
          |
          |
          |----- POST DATA AREA -----|
          | IO_ROM_INIT   DW    1 DUP(?)   ; PNTR TO OPTIONAL I/O ROM INIT ROUTINE
          |-----|
0069 01 [  ???? ]
          |
          |
          | IO_ROM_SEG    DW    1 DUP(?)   ; POINTER TO IO ROM SEGMENT
          |-----|
006B 01 [  ?? ]
          |
          |
          | INTR_FLAG     DB    1 DUP(?)   ; FLAG TO INDICATE AN INTERRUPT HAPPEND
          |-----|
          |
          |----- TIMER DATA AREA -----|
          |
          |
          | TIMER_LOW     DW    1 DUP(?)   ; LOW WORD OF TIMER COUNT
          |-----|
006E 01 [  ???? ]
          |
          |
          | TIMER_HIGH    DW    1 DUP(?)   ; HIGH WORD OF TIMER COUNT
          |-----|
0070 01 [  ?? ]
          |
          |
          | TIMER_OFL     DB    1 DUP(?)   ; TIMER HAS ROLLED OVER SINCE LAST READ
          |-----|
          |
          |----- SYSTEM DATA AREA -----|
          |
          |
          | BIOS_BREAK    DB    1 DUP(?)   ; BIT 7=1 IF BREAK KEY HAS BEEN HIT
          |-----|
0071 01 [  ?? ]
          |
          |
          | RESET_FLAG    DW    1 DUP(?)   ; WORD=1234H IF KEYBOARD RESET UNDERWAY
          |-----|
0072 01 [  ???? ]
          |
          |
          | PAGE
          |-----|
          |
          |----- HARD FILE DATA AREAS -----|
          |
          |
          | DISK_STATUS1  DB    1 DUP(?)
          |-----|
0074 01 [  ?? ]
          |
          |
          | HF_NUM        DB    1 DUP(?)
          |-----|
0075 01 [  ?? ]
          |
          |
          | CONTROL_BYTE  DB    1 DUP(?)
          |-----|
0076 01 [  ?? ]
          |
          |
          | PORT_OFF       DB    1 DUP(?)
          |-----|
0077 01 [  ?? ]
          |
          |
          |----- PRINTER AND RS232 TIME-OUT VARIABLES -----|
          |
          |
          | PRINT_TIM_OUT  DB    4 DUP(?)
          |-----|
0078 04 [  ?? ]
          |
          |
          | RS232_TIM_OUT  DB    4 DUP(?)
          |-----|
007C 04 [  ?? ]
          |
          |
          |----- ADDITIONAL KEYBOARD DATA AREA -----|
          |
          |
          | BUFFER_START   DW    1 DUP(?)
          |-----|
0080 01 [  ???? ]
          |
          |
          | BUFFER_END     DW    1 DUP(?)
          |-----|
0082 01 [  ???? ]
          |
          |
          |----- ADDITIONAL FLOPPY DATA -----|
          |
          |
          |-----|
008B 01 [  ?? ]
          |
          |
          | LASTRATE     ORG    8BH
          | DB    1 DUP(?)   ; LAST DATA RATE SELECTED
          |-----|
          |
          | PAGE
          |-----|
          |
          |----- ADDITIONAL HARD FILE DATA -----|
          |
          |
          |-----|
008C 01 [  ?? ]
          |
          |
          | HF_STATUS     ORG    8CH
          | DB    1 DUP(?)   ; STATUS REGISTER
          |-----|
008D 01 [  ?? ]
          |
          |
          | HF_ERROR      DB    1 DUP(?)   ; ERROR REGISTER
          |-----|
008E 01 [  ?? ]
          |
          |
          | HF_INT_FLAG    DB    1 DUP(?)   ; HARD FILE INTERRUPT FLAG
          |-----|
008F 01 [  ?? ]
          |
          |
          | HF_CNTRL     DB    1 DUP(?)   ; COMBO HARD FILE/FLOPPY CARD BIT 0=1
          |-----|
          |
          |----- ADDITIONAL DISKETTE AREA -----|
          |
          |
          |-----|
0090 01 [  ?? ]
          |
          |
          | DSK_STATE     ORG    90H
          | DB    1 DUP(?)   ; DRIVE 0 MEDIA STATE
          |-----|
0091 01 [  ?? ]
          |
          |
          | DB    1 DUP(?)   ; DRIVE 1 MEDIA STATE
          |-----|
0092 01 [  ?? ]
          |
          |
          | DB    1 DUP(?)   ; DRIVE 0 OPERATION START STATE
          |-----|

```

SECTION 5

```

?? ]
0093 01 [ ?? ] DB 1 DUP(?) ; DRIVE 1 OPERATION START STATE
0094 01 [ ?? ] DSK_TRK DB 1 DUP(?) ; DRIVE 0 PRESENT CYLINDER
0095 01 [ ?? ] DB 1 DUP(?) ; DRIVE 1 PRESENT CYLINDER
0096 01 [ ?? ] DB 1 DUP(?) ; RESERVED
;-----
; ADDITIONAL KEYBOARD LED FLAG :
;-----
0097 01 [ ?? ] ORG 97H
KB_FLAG_2 DB 1 DUP(?)
;-----
PAGE
;-----
; REAL TIME CLOCK DATA AREA :
;-----
0098 01 [ ???? ] ORG 98H
0098 USER_FLAG DW 1 DUP(?) ; OFFSET ADDR OF USERS WAIT FLAG
009A 01 [ ???? ] USER_FLAG_SEG DW 1 DUP(?) ; SEG ADDR OF USER WAIT FLAG
009C 01 [ ???? ] RTC_LOW DW 1 DUP(?) ; LOW WORD OF USER WAIT FLAG
009E 01 [ ???? ] RTC_HIGH DW 1 DUP(?) ; HIGH WORD OF USER WAIT FLAG
00A0 01 [ ?? ] RTC_WAIT_FLAG DB 1 DUP(?) ; WAIT ACTIVE FLAG
00A1 DATA ENDS
;-----
; EXTRA DATA AREA :
;-----
0000 01 [ ?? ] XXDATA SEGMENT AT 50H
0000 STATUS_BYTE DB 1 DUP(?)
0001 XXDATA ENDS
;-----
; VIDEO DISPLAY BUFFER :
;-----
0000 VIDEO_RAM SEGMENT AT 0800H
0000 REGEN LABEL BYTE
0000 REGENW LABEL WORD
0000 4000 [ ?? ] DB 16384 DUP(?)
4000 VIDEO_RAM ENDS
.LIST
C INCLUDE SEGMENT.SRC
C CODE SEGMENT BYTE PUBLIC
C
EXTRN VIDEO_PARAMS:BYTE
EXTRN POST2:NEAR
EXTRN DDS:NEAR
EXTRN D11:NEAR
EXTRN VECTOR_TABLE:NEAR
EXTRN KBD_RESET:NEAR
EXTRN DUMMY_RETURN:NEAR
EXTRN STGTST_CNT:NEAR
EXTRN ERR_BEEP:NEAR
EXTRN ROM_CHECK:NEAR
EXTRN ROS_CHECKSUM:NEAR
EXTRN SYSIN11:NEAR
EXTRN SHUT2:NEAR
EXTRN SHUT3:NEAR
EXTRN SHUT4:NEAR
EXTRN SHUT6:NEAR
EXTRN SHUT7:NEAR
EXTRN SHUT9:NEAR
EXTRN PROC_SHUTDOWN:NEAR
EXTRN C1:NEAR
EXTRN C2:NEAR
EXTRN C8042A:NEAR
EXTRN 0BF_42A:NEAR
EXTRN C8042B:NEAR
EXTRN C8042C:NEAR
EXTRN 0BF_42B:NEAR
EXTRN F3B:NEAR
EXTRN SLAVE_VECTOR_TABLE:NEAR
EXTRN NMI_INT:NEAR
EXTRN PRINT_SCREEN:NEAR
EXTRN GATE_A20:NEAR
ASSUME CS:CODE,SS:CODE,ES:ABS0,DS:DATA
PUBLIC POST1
PUBLIC BEGIN
PUBLIC CHK_VIDEO
PUBLIC START_1
PUBLIC C8042
PUBLIC 0BF_42
PUBLIC C11
PUBLIC C30
PUBLIC TST4_B
PUBLIC TST4_C
PUBLIC TST4_D
PUBLIC E30B
PUBLIC E30C

```

```

= 0000          BEGIN EQU S
;              6 1 8 1 0 2 8 C O P R . I B M 1 9 8 4 ;EVEN
;              6 1 8 1 0 2 9 C O P R . I B M 1 9 8 4 ;ODD
0000 36 36 31 31 38 38 DB '66118811002289 CCOOPRR.. I1BBMM 11998844' ;COPYRIGHT NOTICE
31 31 30 30 32 32
38 39 20 20 43 43
4F 4F 50 50 52 52
2E 2E 20 20 49 49
42 42 4D 4D 20 20
31 31 39 39 38 38
34 34

```

```

;-----
; INITIAL RELIABILITY TESTS -- PHASE 1 :
;-----
002C POST1 PROC NEAR
;-----
; LOAD A BLOCK OF TEST CODE THROUGH THE KEYBOARD PORT
; FOR MANUFACTURING TEST.
; THIS ROUTINE WILL LOAD A TEST (MAX LENGTH=FAFFH) THROUGH
; THE KEYBOARD PORT. CODE WILL BE LOADED AT LOCATION
; 0000:0500. AFTER LOADING, CONTROL WILL BE TRANSFERED
; TO LOCATION 0000:0500. STACK WILL BE LOCATED AT 30:100
; THIS ROUTINE ASSUMES THAT THE FIRST 2
; BYTES TRANSFERED CONTAIN THE COUNT OF BYTES TO BE LOADED
; (BYTE 1=COUNT LOW, BYTE 2=COUNT HI.)
;-----

```

```

002C FA MFG_BOOT:
002C CL1 ; NO INTERRUPTS
;----- DEGATE ADDRESS LINE 20
002D B4 DD MOV AH,DISABLE_BIT20 ; DEGATE COMMAND
002F E8 0000 E CALL GATE_A20 ; ISSUE THE COMMAND
;----- SETUP HARDWARE INT VECTOR TABLE LVL 0-7

```

```

0032 2B C0 SUB AX,AX ;
0034 8E C0 MOV ES,AX ;
0036 B9 0008 MOV CX,08 ; GET VECTOR CNT
0039 0E CS PUSH CS ; SETUP DS SEG REG
003A 1F POP DS
003B BE 0000 E MOV SI,OFFSET VECTOR_TABLE
0052 BF 0020 R MOV DI,OFFSET INT_PTR
0041 A5 MFG_B: MOVSW
0042 47 INC DI ; SKIP OVER SEGMENT
0043 47 INC DI
0044 E2 FB LOOP MFG_B
;----- SETUP HARDWARE INT VECTOR TABLE LVL 8-15 (VECTORS START AT INT 70H)

```

```

0046 2B C0 SUB AX,AX ;
0048 8E C0 MOV ES,AX ;
004A B9 0008 MOV CX,08 ; GET VECTOR CNT
004D 0E CS PUSH CS ; SETUP DS SEG REG
004E 1F POP DS
004F BE 0000 E MOV SI,OFFSET SLAVE_VECTOR_TABLE
0052 BF 01C0 R MOV DI,OFFSET SLAVE_INT_PTR
0055 A5 MFG_C: MOVSW
0056 47 INC DI ; SKIP OVER SEGMENT
0057 47 INC DI
0058 E2 FB LOOP MFG_C
;---- SET UP OTHER INTERRUPTS AS NECESSARY

```

```

005A 2B C0 SUB AX,AX ; DS=0
005C 8E D8 MOV ES,AX ; ES=0
005E 8E C0 MOV ES,AX ;
0060 C7 06 0008 R 0000 E MOV NMI_PTR,OFFSET NMI_INT ; NMI INTERRUPT
0066 C7 06 0014 R 0000 E MOV INT5_PTR,OFFSET PRINT_SCREEN ; PRINT SCREEN
006C C7 06 0062 R F600 MOV BASIC_PTR+2,0F600H ; SEGMENT FOR CASSETTE BASIC
;----- ENABLE KEYBOARD PORT

```

```

0072 B0 60 MOV AL,60H ; WRITE 8042 RAM 0
0074 E8 0405 R CALL C8042 ; ISSUE THE COMMAND
0077 B0 09 MOV AL,00001001B ; SET INHIBIT OVERRIDE/ENABLE OBF INT
0079 E6 60 OUT PORT_A,AL ; AND NOT PC COMP

```

```

007B E8 009D R CALL MFG_2 ; GET COUNT LOW
007E 8A F8 MOV BH,AL ; SAVE IT
0080 EB 009D R CALL MFG_2 ; GET COUNT HI
0083 8A E8 MOV CH,AL ;
0085 8A CF MOV CL,BH ; CX NOW HAS COUNT
0087 FC CLD ; SET DIR. FLAG TO INCRIMENT
0088 BF 0500 MOV DI,0500H ; SET TARGET OFFSET (DS=0000)
008B MFG_1:

```

```

008B E4 64 IN AL,STATUS_PORT ; GET 8042 STATUS PORT
008D A8 01 TEST AL,OUT_BUF_FULL ; KB REQUEST PENDING?
008F 74 FA JZ MFG_1 ; LOOP TILL DATA PRESENT
0091 E4 60 IN AL,PORT_A ; GET DATA
0093 AA STOSB ; STORE IT

```

```

0094 E6 80 OUT MFG_PORT,AL ; DISPLAY CHAR AT MFG PORT
0096 E2 F3 LOOP MFG_1 ; LOOP TILL ALL BYTES READ
0098 EA 0500 ---- R JMP MFG_TEST_RTN ; MFG JUMP TO CODE THAT WAS JUST
; LOADED

```

```

009D E4 64 MFG_2: IN AL,STATUS_PORT ; CHECK FOR OUTPUT BUFF FULL
009F A8 01 TEST AL,OUT_BUF_FULL ; HANG HERE IF NO DATA AVAILABLE
00A1 E1 FA LOOPZ MFG_2

```

```

00A3 E4 60 IN AL,PORT_A ; GET THE COUNT
00A5 C3 RET ;
;-----
; TEST.01
; X286 PROCESSOR TEST (REAL MODE)
; DESCRIPTION
; VERIFY FLAGS, REGISTERS
; AND CONDITIONAL JUMPS
;-----

```

```

00A6 FA ASSUME CS:CODE,DS:DATA,ES:NOTHING,SS:NOTHING
00A7 B4 D5 START_1: CLI ; DISABLE INTERRUPTS
00A9 9E MOV AH,OD5H ; SET SF, CF, ZF, AND AF FLAGS ON
00AA 75 2A JNC SAHF ;
00AC 75 28 JNZ ERRO2 ; GO TO ERR ROUTINE IF CF NOT SET
00AE 7B 26 JNP ERRO2 ; GO TO ERR ROUTINE IF ZF NOT SET
00B0 75 24 JNS ERRO2 ; GO TO ERR ROUTINE IF SF NOT SET
00B2 9F LAHF ; LOAD FLAG IMAGE TO AH

```

SECTION 5

```

00B3 B1 05      MOV     CL,5           ; LOAD CNT REG WITH SHIFT CNT
00B5 D2 EC      SHR     AH,CL        ; SHIFT AF INTO CARRY BIT POS
00B7 73 1D      JNC     ERRO2         ; GO TO ERR ROUTINE IF AF NOT SET
00B9 80 40      MOV     AL,40H        ; SET THE OF FLAG ON
00BB D0 E0      ORH    DO,E0         ; SETUP FOR TESTING
00BD 71 17      XOR     ERO2         ; GO TO ERR ROUTINE IF OF NOT SET
00BF 32 E4      JNO     AH,AH        ; SET AH = 0
00C1 9E         SAHF                    ; CLEAR SF, CF, ZF, AND PF
00C2 76 12      JBE     ERRO2         ; GO TO ERR ROUTINE IF CF ON
00C4 78 10      JS      ERO2         ; GO TO ERR ROUTINE IF ZF ON
00C5 7A 0E      JJP     ERRO2         ; GO TO ERR ROUTINE IF SF ON
00C8 9F         JLP                    ; GO TO ERR ROUTINE IF PF ON
00C9 B1 05      MOV     CL,5           ; LOAD FLAG IMAGE TO AH
00CB D2 EC      SHR     AH,CL        ; LOAD CNT REG WITH SHIFT CNT
00CD D0 E0      ORH    DO,E0         ; SHIFT 'AF' INTO CARRY BIT POS
00CF D0 E4      JNC     AH,1         ; GO TO ERR ROUTINE IF ON
00D1 70 03      JO      ERO2         ; CHECK THAT 'OF' IS CLEAR
00D3 EB 04 90   JMP     C7A           ; GO TO ERR ROUTINE IF ON
00D6 E9 01AC R  ERRO2: JMP     ERRO1        ; CONTINUE
                                ; ERROR EXIT

00D9
00D9 B8 ---- R  C7A:      MOV     AX,DATA       ; SET DATA SEGMENT
00DC 8E D8      MOV     DS,AX

;----- CHECK FOR PROCESSOR SHUTDOWN

00DE E4 64      IN      AL,STATUS_PORT ; CHECK FOR SHUTDOWN
00E0 A8 04      TEST   AL,SYS_FLAG   ;
00E2 75 03      JNZ    C7B           ; GO IF YES
00E4 E9 0181 R  JMP     C7            ;

;----- CHECK FOR SHUTDOWN 9

00E7
00E7 B0 8F      MOV     AL,SHUT_DOWN ; CMOS ADDR FOR SHUTDOWN BYTE
00E9 E6 70      OUT    CMOS_PORT,AL  ;
00EB EB 00      JMP     SHORT $+2     ; IO DELAY
00ED E4 71      IN      AL,CMOS_PORT+1 ; GET WHO
00EF 86 C4      XCHG   AL,AH         ; SAVE THE SHUTDOWN REQUEST
00F1 80 FC 09   CMP     AH,09H        ; WAS IT SHUTDOWN REQUEST 9?
00F4 74 3C      JZ      C7C          ; BYPASS INIT OF INT CHIPS

-----
RE-INITIALIZE THE 8259 INTERRUPT #1 CONTROLLER CHIP :
-----

00F6 2A C0      SUB     AL,AL         ; INSURE MATH PROCESSOR RESET
00F8 E6 F1      OUT    X2B7+1,AL     ;
00FA B0 11      MOV     AL,11H        ; ICW1 - EDGE, MASTER, ICW4
00FC E6 20      OUT    INTA00,AL     ;
00FE EB 00      JMP     SHORT $+2     ; WAIT STATE FOR IO
0100 B0 08      MOV     AL,8          ; SETUP ICW2 - INT TYPE 8 (8-F)
0102 E6 21      OUT    INTA01,AL     ;
0104 EB 00      JMP     SHORT $+2     ; WAIT STATE FOR IO

0106 B0 04      MOV     AL,04H        ; SETUP ICW3 - MASTER LV 2
0108 E6 21      OUT    INTA01,AL     ;
010A EB 00      JMP     SHORT $+2     ; IO WAIT STATE
010C B0 01      MOV     AL,01H        ; SETUP ICW4 - MASTER,8086 MODE
010E E6 21      OUT    INTA01,AL     ;
0110 EB 00      JMP     SHORT $+2     ; WAIT STATE FOR IO
0112 B0 FF      MOV     AL,0FH        ; MASK ALL INTS. OFF
0114 E6 21      OUT    INTA01,AL     ; (VIDEO ROUTINE ENABLES INTS.)

-----
RE-INITIALIZE THE 8259 INTERRUPT #2 CONTROLLER CHIP :
-----

0116 B0 11      MOV     AL,11H        ; ICW1 - EDGE, SLAVE ICW4
0118 E6 A0      OUT    INTB00,AL     ;
011A EB 00      JMP     SHORT $+2     ; WAIT STATE FOR IO
011C B0 70      MOV     AL,INT_TYPE   ; SETUP ICW2 - INT TYPE 50 (50-5F)
011E E6 A1      OUT    INTB01,AL     ;
0120 B0 02      MOV     AL,02H        ; SETUP ICW3 - SLAVE LV 2
0122 EB 00      JMP     SHORT $+2     ;
0124 E6 A1      OUT    INTB01,AL     ;
0126 EB 00      JMP     SHORT $+2     ; IO WAIT STATE
0128 B0 01      MOV     AL,01H        ; SETUP ICW4 - 8086 MODE, SLAVE
012A E6 A1      OUT    INTB01,AL     ;
012C EB 00      JMP     SHORT $+2     ; WAIT STATE FOR IO
012E B0 FF      MOV     AL,0FH        ; MASK ALL INTS. OFF
0130 E6 A1      OUT    INTB01,AL     ;

-----
SHUTDOWN
RETURN CONTROL AFTER A SHUTDOWN COMMAND IS ISSUED
DESCRIPTION
A TEST IS MADE FOR THE SYSTEM FLAG BEING SET. IF
THE SYSTEM FLAG IS SET, THE SHUTDOWN BYTE IN CMOS
IS USED TO DETERMINE WHERE CONTROL IS RETURNED.

CMOS = 0   SOFT RESET OR UNEXPECTED SHUTDOWN
CMOS = 1   SHUT DOWN AFTER MEMORY SIZE
CMOS = 2   SHUT DOWN AFTER MEMORY TEST
CMOS = 3   SHUT DOWN WITH MEMORY ERROR
CMOS = 4   SHUT DOWN WITH BOOT LOADER REQUEST
CMOS = 5   JMP DWORD REQUEST (WITH INT INIT)
CMOS = 6   PROTECTED MODE TEST7 PASSED
CMOS = 7   PROTECTED MODE TEST7 FAILED
CMOS = 8   PROTECTED MODE TEST1 FAILED
CMOS = 9   BLOCK MOVE SHUTDOWN REQUEST
CMOS = A   JMP DWORD REQUEST (W/O INT INIT)

----- CHECK FROM WHERE

0132 B0 8F      MOV     AL,SHUT_DOWN ; CLEAR CMOS BYTE
0134 E6 70      OUT    CMOS_PORT,AL  ;
0136 EB 00      JMP     SHORT $+2     ; IO DELAY
0138 2A C0      SUB     AL,AL         ; SET BYTE TO 0
013A E6 71      OUT    CMOS_PORT+1,AL ;
013C 86 E0      XCHG   AH,AL         ;
013E 3C 0A      CMP     AL,0AH        ; MAX TABLE ENTRIES
0140 77 2C      JA     SHUTO         ; GO IF GREATER THAN MAX
0142 BE 0158 R  MOV     SI,OFFSET_BRANCH ; GET THE START OF BRANCH TABLE
0145 03 F0      ADD     SI,AX         ;
0147 03 F0      ADD     SI,AX         ;
0149 2E: 8B 1C  MOV     BX,CS:[SI]   ; POINT TO BRANCH ADDRESS
014C FA         CUI                    ; GET BRANCH TO BX
014D B8 ---- R  MOV     AX,STACK     ; SET STACK
0150 8E D0      MOV     SS,AX        ;
0152 BC 0100 R  MOV     SP,OFFSET_TOS ;
0155 FB         STI                    ;
0156 FF E3      JMP     BX           ; JUMP BACK

0158 016E R     BRANCH: DW     SHUTO   ; NORMAL POWER UP/UNEXPECTED SHUTDOWN
015A 09B0 R     DW     SHUT1      ; SHUT DOWN AFTER MEMORY SIZE
015C 0000 E     DW     SHUT2      ; SHUT DOWN AFTER MEMORY TEST

```



```

015E 0000 E           DW      SHUT3      ; SHUT DOWN WITH MEMORY ERROR
0160 00074           DW      SHUT4      ; SHUT DOWN WITH BOOT LOADER REQUEST
0162 0171 R           DW      SHUT5      ; JMP DWORD REQUEST (WITH INTERRUPT INIT)
0164 0000 E           DW      SHUT6      ; PROTECTED MODE TEST7 PASSED
0166 0000 E           DW      SHUT7      ; PROTECTED MODE TEST7 FAILED
0168 0177 R           DW      SHUT8      ; PROTECTED MODE TEST1 FAILED
016A 0000 E           DW      SHUT9      ; BLOCK MOVE SHUTDOWN REQUEST
016C 017D R           DW      SHUTA     ; JMP DWORD REQUEST (W/O INTERRUPT INIT)
016E EB 11 90        SHUTO:  JMP      C7

;----- IO_ROM_INIT MUST BE INITIALIZED BY THE USER
; FLUSH THE KEYBOARD BUFFER
; CLEAR IF OUTPUT BUFFER FULL
0171 E4 64           SHUT5:  IN       AL,STATUS_PORT
0173 A8 01           TEST    AL,OUT_BUF_FULL
0175 74 02           JZ      SHUT5B     ; GO IF NOT
0177 E4 60           IN      AL,PORT_A  ; FLUSH
0179 B0 20           MOV     EDI,EDI    ; FLUSH LAST TIMER TICK
017B E6 20           OUT    INTA00,AL  ; -TO ALLOW TIMER INTERRUPTS

017D FF 2E 0067 R    SHUTA:  JMP      DWORD PTR DS:IO_ROM_INIT;

;----- CHECKPOINT 1

0181 B0 01           C7:     MOV     AL,01H    ; <<<<<<<<<<<<<<<<<<<<<<
0183 E6 80           OUT    MFG_PORT,AL ; <<<<<<<<<<<<<<<<<<<<<<

;----- READ/WRITE THE X286 GENERAL AND SEGMENTATION REGISTERS
; WITH ALL ONE'S AND ZEROES'S.

0185 B8 FFFF         MOV     AX,OFFFHH  ; SETUP ONE'S PATTERN IN AX
0188 F9              STC              ; SET CARRY FLAG
0189 73 21          JNC     ERROR1    ; GO IF NO CARRY
018B 8E D8          MOV     DS,AX     ; WRITE PATTERN TO ALL REGS
C8:  MOV     ES,DS
018F 8E C3          MOV     ES,BX
0191 8C C1          MOV     CX,ES
0193 8E D1          MOV     SS,CX
0195 8C D2          MOV     DX,SS
0197 8B E2          MOV     SP,DX
0199 8B EC          MOV     BP,SP
019B 8B F5          MOV     SI,BP
019D 8B FE          MOV     DI,SI
019F 73 07          JNC     C9        ;
01A1 33 07          XOR     AX,DI     ; PATTERN MAKE IT THRU ALL REGS
01A3 75 07          JNZ    ERROR1    ; NO - GO TO ERR ROUTINE
01A5 FB            CLC              ; CLEAR CARRY FLAG
01A6 EB E3          JMP     C8
C9:  OR      AX,DI     ; TST1A
01A8 0B 07          OR      JZ,AX,DI  ; ZERO PATTERN MAKE IT THRU?
01AA 74 C1          JZ      YES      ; YES - GO TO NEXT TEST
01AC F4            HLT      ; HALT SYSTEM

;----- INSURE THAT CMOS CLOCK INTERRUPTS ARE DISABLED

01AD B0 8B          C10A:  MOV     AL,CMOS_ALARM ;
01AF E6 70          OUT    CMOS_PORT,AL ;
01B1 EB 00          JMP     SHORT $+2   ;
01B3 E4 71          IN     AL,CMOS_PORT+1 ; GET THE CURRENT CONTROL REG
01B5 86 C4          XCHG  AL,AH        ; SAVE IT
01B7 80 E4 07      AND    AH,07H      ; CLEAR SET,PIE,AIE, AND SQWE BITS
01BA B0 8B          MOV     AL,CMOS_ALARM ;
01BC E6 70          OUT    CMOS_PORT,AL ;
01BE 86 C4          XCHG  AL,AH        ;
01C0 EB 00          JMP     SHORT $+2   ;
01C2 E6 71          OUT    CMOS_PORT+1,AL ;
;
01C4 EB 00          JMP     SHORT $+2   ;
01C6 B0 8C          MOV     AL,CMOS_ALARM+1 ;
01C8 E6 70          OUT    CMOS_PORT,AL ; CLEAR PENDING INTERRUPT
01CA EB 00          JMP     SHORT $+2   ;
01CC E4 71          IN     AL,CMOS_PORT+1 ;
;

;----- RESET VIDEO

01CE B8 ---- R      ASSUME  DS:DATA
01D1 8E D8          MOV     DS,AX
01D3 81 3E 0072 R 1234 CMP     RESET_FLAG,1234H ; SET DATA SEGMENT
01D9 74 0B          JZ      SFT_RST     ; SOFT RESET?
; GO IF YES

01DB 2A C0          SUB     AL,AL
01DD BA 03DB      MOV     DX,3DBH
01E0 EE            OUT    DX,AL        ; DISABLE COLOR VIDEO
01E1 FE C0          INC    AL
01E3 B2 88          MOV     DL,0B8H
01E5 EE            OUT    DX,AL        ;
01E6 B0 FC          SFT_RST:MOV AL,1111100B ; DISABLE B/W VIDEO,EN HIGH RES
01E8 E6 61          OUT    PORT_B,AL   ;

;----- TEST.02
;
; VERIFY CMOS SHUTDOWN BYTE
;
; DESCRIPTION
;
; ROLLING BIT WRITTEN AND VERIFIED
;
; AT SHUTDOWN ADDRESS
;

;----- VERIFY AND CLEAR SHUTDOWN FLAG

01EA B0 02          MOV     AL,2
01EC E6 80          OUT    MFG_PORT,AL ; <<<<<<<<<<<<<<<<<<<<<<
; <<<<<<<<<<<<<<<<<<<<<<

01EE B9 0009      MOV     CX,9       ; LOOP COUNT
01F1 B4 01          MOV     AH,1       ; START WITH BIT 0
C10B: MOV     AL,SHUT_DOWN ;
01F3 B0 8F          OUT    CMOS_PORT,AL ;
01F5 E6 70          MOV     AL,AH      ; OUTPUT ROLLING BIT
01F7 8A C4          MOV     AL,AH      ;
01F9 EB 00          JMP     SHORT $+2   ; IO DELAY
01FB E6 71          OUT    CMOS_PORT+1,AL ;
01FD B0 8F          MOV     AL,SHUT_DOWN ; READ CMOS
01FF EB 00          JMP     SHORT $+2   ; IO DELAY
0201 E6 70          OUT    CMOS_PORT,AL ;
0203 EB 00          JMP     SHORT $+2   ; IO DELAY
0205 E4 71          IN     AL,CMOS_PORT+1 ;
0207 3A C4          CMP     AL,AH      ; MUST BE THE SAME
0209 75 A1          JNZ    ERROR1    ; ERROR IF NOT
020B D0 D4          RCL    AH,1       ; ROLL A BIT THRU SHUT DOWN
020D E2 E4          LOOP   C10B       ; LOOP TILL DONE

;----- TEST.03
;
; ROS CHECKSUM TEST 1
;
; DESCRIPTION
;
; A CHECKSUM IS DONE FOR THE 32K
;
; ROS MODULES CONTAINING POD AND

```



```

03E8 EB 27 90      JMP      OBF_42          ; GO WAIT FOR RESPONSE
03EB E4 60      E30C: IN      AL,PORT_A    ; GET THE SWITCH
03ED E6 82      OUT     DMA_PAGE+1,AL   ; SAVE TEMP

;----- WRITE BYTE 0 OF 8042 RAM

03EF B0 60      MOV     AL,60H          ; WRITE BYTE COMMAND
03F1 BC 0000 E  MOV     SP,OFFSET C8042B ; SET RETURN ADDR
03F4 EB 0F 90    JMP     C8042          ; ISSUE THE COMMAND
03F7 74 05      TST4_D: JZ      TST4_D1   ; CONTINUE IF COMMAND ACCEPTED

03F9 B0 0D      MOV     AL,0DH          ; <<<<<<<<<<<<<<<<<<<<<<<<<
03FB E6 80      OUT     MFG_PORT,AL    ; <<<<<<<<<<<<<<<<<<<<<<<<<
03FD F3 00      HLT                                ;
03FE B0 5D      TST4_D1:MOV    AL,5DH    ; ENABLE OUTPUT BUFF FULL INT - DISABLE KEYBOARD
0400 E6 60      OUT     PORT_A,AL      ; SET SYS FLAG - PC 1 COMP - INH OVERRIDE
0402 EB 1E 90    JMP     E30A           ; CONTINUE

;----- ISSUE THE COMMAND TO THE 8042

0405 FA         C8042: CLI      STATUS_PORT,AL ; NO INTERRUPTS ALLOWED
0406 E6 64      OUT                                ; SEND COMMAND IN AL REG

0408 2B C9      SUB     CX,CX          ; LOOP COUNT
040A E4 64      IN     AL,STATUS_PORT ; WAIT FOR THE COMMAND ACCEPTED
040C A6 02      TEST   AL,INPT_BUF_FULL
040E E0 FA      LOOPNZ C42_1
0410 C3         RET

;----- WAIT FOR 8042 RESPONSE

0411 2B C9      OBF_42: SUB    CX,CX     ;
0413 B3 06      MOV     BL,6          ; 200MS/PER LOOP * 6 =1200 MS +
0415 E4 64      C42_2: IN     AL,STATUS_PORT ; CHECK FOR RESPONSE
0417 A6 01      TEST   AL,OUT_BUF_FULL
0419 75 06      JNZ    C42_3          ; GO IF RESPONSE
041B E2 F8      LOOP   C42_2         ; TRY AGAIN
041D FE CB      DEC    BL            ; DECREMENT LOOP COUNT
041F 75 F4      JNZ    C42_2
0421 C3         C42_3: RET            ; RETURN TO CALLER

-----
; TEST_11
; BASE 64K READ/WRITE STORAGE TEST
; DESCRIPTION
; WRITE/READ/VERIFY DATA PATTERNS
; AA,55,FF,01, AND 00 TO 1ST 64K OF
; STORAGE, VERIFY STORAGE ADDRESSABILITY.
-----

;---- FILL MEMORY WITH DATA

0422 B0 0E      E30A: MOV     AL,0EH       ;SET CHECKPOINT (E)
0424 E6 80      OUT     MFG_PORT,AL   ;<<<<<<<<<<<<<<<<<<<<<<<<<

0426 B8 ---- R  MOV     AX,DATA        ; GET THE SYSTEM SEGMENT
0429 8E D8      MOV     DS,AX          ; OF DATA
042B 8B 1E 0072 R  MOV     BX,RESET_FLAG ; SAVE RESET_FLAG IN BX
042F FC        CLD                    ; SET DIR FLAG TO INC.
0430 B9 8000     MOV     CX,2000H*4    ; SET FOR 32K WORDS
0433 2B FF      SUB     DI,D1         ; FIRST 16K
0435 2B F6      SUB     SI,S1         ;
0437 2B C0      SUB     AX,AX         ;
0439 8E D8      MOV     DS,AX        ;
043B 8E C0      MOV     ES,AX        ;
043D 81 FB 1234  CMP     BX,1234H     ; WARM START?
0441 75 03      JNZ    E30A_0        ; GO IF NOT?
0443 E9 05E6 R   JMP     CLR_STG

;----- GET THE INPUT BUFFER (SWITCH SETTINGS)

0446 B0 0F      E30A_0:MOV    AL,0FH    ; <<<<<<<<<<<<<<<<<<<<<<<<<<<<
0448 E6 80      OUT     MFG_PORT,AL   ; <>>>>>>>>>>>>>>>>>>>>>>>>>

044A B0 80      MOV     AL,PRTY_CHK   ; SET BASE RAM PARITY
044C E6 87      OUT     DMA_PAGE+6,AL ; USE AS TEMP SAVE
044E BC 0000 E   MOV     SP,OFFSET C2  ; SET RETURN ADDRESS
0451 E9 0000 E   JMP     STGTST_CNT    ;
0454 8B D8      C30:  MOV     BX,AX        ; SAVE FAILING BIT PATTERN
0456 75 03      JNZ    C31           ;
0458 E9 05F1 R   JMP     C33          ; STORAGE OK, CONTINUE

-----
; BASE 64K STORAGE FAILURE
; DISPLAY THE CHECKPOINT (MFG CHECKPOINT)
; AND XOR EXPECTED WITH READ IN MFG_PORT
; DISPLAY CHECKPOINT IN MFG_PORT+3
; DISPLAY XOR'D DATA HIGH BYTE MFG_PORT+1
; LOW BYTE IN MFG_PORT+2
; A READ/WRITE SCOPE LOOP OF THE FIRST
; WORD FOR POSSIBLE ADDRESS LINE FAILURES
-----

045B 8A C7      C31:  MOV     AL,BH         ; SAVE HIGH BYTE
045D E6 81      OUT     MFG_PORT+1,AL ;
045F 8A C3      MOV     AL,BL        ; SAVE LOW BYTE
0461 E6 82      OUT     MFG_PORT+2,AL ;

;----- CHECK FOR VIDEO ROM

0463 B9 C000     MOV     CX,OC000H    ; START OF IO ROM
0466 8E D9      M1:  MOV     DS,CX        ;
0468 2B DB      SUB     BX,BX        ; GET THE FIRST 2 LOCATIONS
046A 8B 07      MOV     AX,[BX]     ;
046C EB 00      JMP     SHORT $+2    ;
046E 3D AA55     CMP     AX,0AA55H    ; BUS SETTLE
0471 74 0C      JZ     Z5           ; IS THE VIDEO ROM PRESENT?
0473 81 C1 0080  ADD     CX,080H     ; GO IF YES
0477 81 F9 C800  CMP     CX,OC800H   ; POINT TO NEXT 2K BLOCK
047B 7C E9      JL     M1           ; TOP OF VIDEO ROM AREA YET?
047D 23 C9      AND     CX,CX       ; TRY AGAIN
; SET NON ZERO FLAG

047F 75 03      Z5:  JNZ    C32          ; GO IF NOT
0481 E9 0573 R   JMP     C31_0        ; BYPASS ERROR DISPLAY IF VIDEO ROM

-----
; SET VIDEO MODE TO DISPLAY MEMORY ERROR
; THIS ROUTINE INITIALIZES THE ATTACHMENT TO
; TO DISPLAY FIRST 64K STORAGE ERRORS
; BOTH COLOR AND MONO ATTACHMENTS ARE INITIALIZED.
-----

M4 EQU 10H
;---- INIT COLOR/MONO

0484 BA 03D8     C32:  MOV     DX,3DBH     ; CONTROL REG ADDRESS OF COLOR CARD
0487 2A C0      SUB     AL,AL       ; MODE SET
0489 EE      OUT     DX,AL      ;

```

```

048A BA 0388      MOV     DX,0388H      ; CONTROL REG ADDRESS OF BW CARD
048D B0 01        MOV     AL,1          ; MODE SET FOR CARD
048F EE           OUT     DX,AL         ; RESET VIDEO
0490 83 EA 04     SUB     DX,4          ; BACK TO BASE REGISTER

0493 BB 0030 E     MOV     BX,OFFSET VIDEO_PARAMS+M4*3 ; POINT TO VIDEO PARAMS
                                ASSUME DS:CODE
0496 B9 0010     Z_2:  MOV     CX,M4          ; COUNT OF MONO VIDEO PARAMS
                                ;----- BX POINTS TO CORRECT ROW OF INITIALIZATION TABLE
0499 32 E4        XOR     AH,AH         ; AH WILL SERVE AS REGISTER NUMBER DURING LOOP
                                ;----- LOOP THROUGH TABLE, OUTPUTTING REG ADDRESS, THEN VALUE FROM TABLE

049B 8A C4        M10:  MOV     AL,AH         ; GET 6845 REGISTER NUMBER
049D EE          OUT     DX,AL         ;
049E 42          INC     DX            ; POINT TO DATA PORT
049F FE C4       INC     AH            ; NEXT REGISTER VALUE
04A1 2E: 8A 07  MOV     AL,CS:[BX]   ; GET TABLE VALUE
04A4 EE          OUT     DX,AL         ; OUT TO CHIP
04A5 43          INC     BX            ; NEXT IN TABLE
04A6 4A          DEC     DX            ; BACK TO POINTER REGISTER
04A7 E2 F2      LOOP  M10            ; DO THE WHOLE TABLE
04A9 8A E2      MOV     AH,DL         ; CHECK IF COLOR CARD DONE
04AB 80 E4 F0  AND     AH,0F0H      ; STRIP UNWANTED BITS
04AE 80 FC D0  CMP     AH,0D0H      ; IS IT THE COLOR CARD?
04B1 74 08      JZ     Z_3            ; CONTINUE IF COLOR
04B3 BB 0000 E   MOV     BX,OFFSET VIDEO_PARAMS ; POINT TO VIDEO PARAMS
04B6 BA 03D4     MOV     DX,3D4H      ; COLOR BASE
04B9 EB DB      JMP     Z_2            ; CONTINUE

                                ;----- FILL REGEN AREA WITH BLANK
04BB 33 FF      Z_3:  XOR     DI,DI         ; SET UP POINTER FOR REGEN
04BD BB 8000     MOV     AX,0B000H    ; SET UP ES TO VIDEO REGEN
04C0 8E C0      MOV     ES,AX        ;
                                ;
04C2 B9 0800     MOV     CX,2048      ; NUMBER OF WORDS IN MONO CARD
04C5 B8 0720     MOV     AX,1*7*256   ; FILL CHAR FOR ALPHA
04C8 F3/ AB     REP     STOSW        ; FILL THE REGEN BUFFER WITH BLANKS

04CA 33 FF      XOR     DI,DI         ; CLEAR COLOR VIDEO RAM
04CC BB B800     MOV     BX,0B800H    ; SET UP ES TO COLOR VIDEO RAM
04CF 8E C3      MOV     ES,BX        ;
04D1 B9 2000     MOV     CX,8192      ;
04D4 F3/ AB     REP     STOSW        ; FILL WITH BLANKS

                                ;----- ENABLE VIDEO AND CORRECT PORT SETTING
04D6 BA 0388     MOV     DX,388H      ;
04D9 B0 29      MOV     AL,29H       ;
04DB EE          OUT     DX,AL         ; SET VIDEO ENABLE PORT

                                ;----- SET UP OVERSCAN REGISTER
04DC 42          INC     DX            ;
04DD B0 30      MOV     AL,30H       ; VALUE OF 30H FOR ALL MODES EXCEPT 640X200
04DF EE          OUT     DX,AL         ; OUTPUT THE CORRECT VALUE TO 3D9 PORT

                                ;----- ENABLE COLOR VIDEO AND CORRECT PORT SETTING
04E0 BA 03D8     MOV     DX,3D8H      ;
04E3 B0 28      MOV     AL,28H       ;
04E5 EE          OUT     DX,AL         ; SET VIDEO ENABLE PORT

                                ;----- SET UP OVERSCAN REGISTER
04E6 42          INC     DX            ;
04E7 B0 30      MOV     AL,30H       ; VALUE OF 30H FOR ALL MODES EXCEPT 640X200
04E9 EE          OUT     DX,AL         ; OUTPUT THE CORRECT VALUE TO 3D9 PORT

                                ;----- DISPLAY FAILING CHECKPOINT AND
04EA 8C C8      MOV     AX,CS         ; SET STACK SEGMENT TO CODE SEGMENT
04EC 8E D0      MOV     SS,AX        ;
                                ;
04EE BB B000     MOV     BX,0B000H    ;
04F1 8E DB      MOV     DS,BX        ; SET DS TO BW CRT BUFFER

                                ;
04F3 B0 30      Z_0:  MOV     AL,'0'        ; DISPLAY BANK 000000
04F5 B9 0006     MOV     CX,6          ;
04F8 28 FF      SUB     DI,DI         ; START AT 0
04FA B8 05      MOV     DS:[DI],AL   ; WRITE TO CRT BUFFER
04FC 47          INC     DI            ; POINT TO NEXT POSITION
04FD 47          INC     DI            ;
04FE E2 FA      LOOP  Z              ;

0500 80 FF B8     CMP     BH,0B8H      ; CHECK THAT COLOR BUFFER WRITTEN
0503 74 0C      JNC    Z_1            ;
0505 28 FF      SUB     DI,DI         ; POINT TO START OF BUFFER

0507 B7 B0      MOV     BH,0B0H      ;
0509 8E C3      MOV     ES,BX        ; ES = MONO
050B B7 B8      MOV     BH,0B8H      ; SET SEGMENT TO COLOR
050D 8E DB      MOV     DS,BX        ; DS = COLOR
050F EB E2      JMP     Z_0            ;

                                ;----- PRINT FAILING BIT PATTERN
0511 B0 20      Z_1:  MOV     AL,' '        ; DISPLAY A BLANK
0513 B8 05      MOV     DS:[DI],AL   ; WRITE TO COLOR BUFFER
0515 26: 88 05  MOV     ES:[DI],AL   ; WRITE TO MONO BUFFER
0518 47          INC     DI            ; POINT TO NEXT POSITION
0519 47          INC     DI            ;
051A E4 B1      IN     AL,MFG_PORT+1 ; GET THE HIGH BYTE OF FAILING PATTERN
051C B1 04      MOV     CL,4          ; SHIFT COUNT
051E D2 E8      SHR     AL,CL         ; NIBBLE SWAP
0520 BC 05D0 R   MOV     SP,OFFSET Z1_0
0523 EB 1E 90   JMP     PR            ;

0526 E4 B1      Z1:  IN     AL,MFG_PORT+1 ;
0528 24 0F      AND     AL,0FH       ; ISOLATE TO LOW NIBBLE
052A BC 05E0 R   MOV     SP,OFFSET Z2_0
052D EB 14 90   JMP     PR            ;
0530 E4 B2      IN     AL,MFG_PORT+2 ;
0532 B1 04      MOV     CL,4          ; SHIFT COUNT
0534 D2 E8      SHR     AL,CL         ; NIBBLE SWAP
0536 BC 05E2 R   MOV     SP,OFFSET Z3_0
0539 EB 08 90   JMP     PR            ;
053C E4 B2      Z3:  IN     AL,MFG_PORT+2 ;
053E 24 0F      AND     AL,0FH       ; ISOLATE TO LOW NIBBLE
0540 BC 05E4 R   MOV     SP,OFFSET Z4_0 ; RETURN TO Z4:

                                ;----- CONVERT AND PRINT

```

```

0543 04 90 PR: ADD AL,090H ; CONVERT 00-0F TO ASCII CHARACTER
0545 27 DAA ; ADD FIRST CONVERSION FACTOR
0546 14 40 ADC AL,040H ; ADJUST FOR NUMERIC AND ALPHA RANGE
0548 27 DAA ; ADD CONVERSION AND ADJUST LOW NIBBLE
; ADJUST HIGH NIBBLE TO ASCII RANGE
0549 88 05 MOV DS:[D1],AL ; WRITE TO COLOR BUFFER
054B 26: 88 05 MOV ES:[D1],AL ; WRITE TO MONO BUFFER
054E 47 INC D1 ; POINT TO NEXT POSTITON
054F 47 INC D1
0550 C3 RET

;----- DISPLAY 201 ERROR
0551 80 20 Z4: MOV AL,' ' ; DISPLAY A BLANK
0553 88 05 MOV DS:[D1],AL ; WRITE TO CRT BUFFER
0555 26: 88 05 MOV ES:[D1],AL ; WRITE TO MONO BUFFER
0558 47 INC D1 ; POINT TO NEXT POSTITON
0559 47 INC D1
055A 80 32 MOV AL,'2' ; DISPLAY 201 ERROR
055C 88 05 MOV DS:[D1],AL ; WRITE TO CRT BUFFER
055E 26: 88 05 MOV ES:[D1],AL ; WRITE TO MONO BUFFER
0561 47 INC D1 ; POINT TO NEXT POSTITON
0562 47 INC D1
0563 80 30 MOV AL,'0' ;
0565 88 05 MOV DS:[D1],AL ; WRITE TO CRT BUFFER
0567 26: 88 05 MOV ES:[D1],AL ; WRITE TO MONO BUFFER
056A 47 INC D1 ; POINT TO NEXT POSTITON
056B 47 INC D1
056C 80 31 MOV AL,'1' ;
056E 88 05 MOV DS:[D1],AL ; WRITE TO CRT BUFFER
0570 26: 88 05 MOV ES:[D1],AL ; WRITE TO MONO BUFFER

;----- ROLL ERROR CODE IN MFG_PORT --> FIRST THE CHECKPOINT
0573 80 DD C31_0: MOV AL,0DDH ; <<<<<<<<<<<<<<<<<<<<<<<<<<<<
0575 E6 80 OUT MFG_PORT,AL ; <<<<<<<<<<<<<<<<<<<<<<<<<<<<
0577 E6 83 OUT MFG_PORT+3,AL ; ALSO DISPLAY CHECK POINT IN PORT 83
0579 2B C9 SUB CX,CX
057B C31_A: SUB AX,AX ; SETUP SEGMENT
057D 8E D8 MOV DS,AX ; WRITE AN AA55
057F 88 AA55 MOV AX,0AA55H
0582 2B FF SUB D1,D1
0584 89 05 MOV DS:[D1],AX ;
0586 88 05 MOV AX,DS:[D1] ; READ THE FIRST WORD
0588 E2 F1 LOOP C31_A ; DISPLAY CHKPT LONGER
058A 89 05 MOV DS:[D1],AX ;
058C 88 05 MOV AX,DS:[D1] ;
058E E2 FA LOOP C31_B ;
0590 C31_C: MOV DS:[D1],AX ;
0592 88 05 MOV AX,DS:[D1] ;
0594 E2 FA LOOP C31_C ;
0596 C31_D: MOV DS:[D1],AX ;
0598 88 05 MOV AX,DS:[D1] ;
059A E2 FA LOOP C31_D ;
059C C31_E: MOV DS:[D1],AX ;
059E 88 05 MOV AX,DS:[D1] ;
059F E2 FA LOOP C31_E ;

;----- ROLL ERROR CODE IN MFG_PORT --> NEXT THE HIGH BYTE
05A2 E4 81 IN AL,MFG_PORT+1 ; XOR OF FAILING BIT PATTERN
05A4 E6 80 OUT MFG_PORT,AL ; HIGH BYTE
05A6 C31_G: MOV AX,0AA55H ; WRITE AN AA55
05A8 89 05 MOV DS:[D1],AX ;
05AB 88 05 MOV AX,DS:[D1] ; READ THE FIRST WORD
05AD E2 F7 LOOP C31_G ;
05AF C31_H: MOV DS:[D1],AX ;
05B1 88 05 MOV AX,DS:[D1] ;
05B3 E2 FA LOOP C31_H ;
05B5 C31_I: MOV DS:[D1],AX ;
05B7 88 05 MOV AX,DS:[D1] ;
05B9 E2 FA LOOP C31_I ;

;----- ROLL ERROR CODE IN MFG_PORT --> THEN THE LOW BYTE
05BB E4 82 IN AL,MFG_PORT+2 ; LOW BYTE
05BD E6 80 OUT MFG_PORT,AL ; WRITE AN AA55
05BF 88 AA55 MOV AX,0AA55H
05C2 2B FF SUB D1,D1
05C4 89 05 MOV DS:[D1],AX ; READ THE FIRST WORD
05C6 88 05 MOV AX,DS:[D1] ;
05C8 E2 F8 LOOP C31_K ;
05CA C31_L: MOV DS:[D1],AX ;
05CC 88 05 MOV AX,DS:[D1] ;
05CE E2 FA LOOP C31_L ;
05D0 C31_M: MOV DS:[D1],AX ;
05D2 88 05 MOV AX,DS:[D1] ;
05D4 E2 FA LOOP C31_M ;
05D6 C31_N: MOV DS:[D1],AX ;
05D8 88 05 MOV AX,DS:[D1] ;
05DA E2 FA LOOP C31_N ; DO AGAIN
05DC EB 95 JMP C31_0

05DE 0526 R Z1_0 DW Z1 ; TEMP STACK
05E0 0530 R Z2_0 DW Z2 ; TEMP STACK
05E2 053C R Z3_0 DW Z3 ; TEMP STACK
05E4 0551 R Z4_0 DW Z4 ; TEMP STACK

;----- CLEAR STORAGE ENTRY
05E6 CLR_STG: ASSUME DS:DATA ;
REP STOSH ; STORE 32K WORDS OF 0000
MOV AX,DATA ; RESTORE DATA SEGMENT
MOV DS,AX ;
MOV RESET_FLAG,BX ; RESTORE RESET FLAG

;----- SETUP STACK SEG AND SP
05F1 88 ---- R C33: MOV AX,DATA ; SET DATA SEGMENT
05F4 8E D8 MOV DS,AX ; TEMP STACK
05F6 BC 0000 MOV SP,POST_SS ; GET STACK VALUE
05F9 8E D4 MOV SS,SP ; SET THE STACK UP

```



```

097F C6 06 004C 80      MOV  BYTE PTR DS:(ES_TEMP.BASE_HI_BYTE),80H
0984 E8 098A R          CALL SDO
;
0987 EB 20 90          JMP  SD2                ; TEST PASSED CONTINUE
;
098A 28 FF            SDO: SUB  D1,D1
098C B8 0048        MOV  AX,ES_TEMP        ; POINT ES TO DATA
098F 8E C0          MOV  ES,AX             ; POINT TO SEGMENT TO TEST
0991 26: 89 15      MOV  ES:[D1],DX       ; WRITE THE PATTERN
;
0994 C6 06 004C 00      MOV  BYTE PTR DS:(ES_TEMP.BASE_HI_BYTE),00H
;
0999 B8 0048        MOV  AX,ES_TEMP        ; POINT ES TO DATA
099C 8E C0          MOV  ES,AX             ; POINT TO SEGMENT TO TEST
099E 26: 81 3D FFFF  CMP  WORD PTR ES:[D1],0FFFFH ; DID LOCATION 0 CHANGE?
09A3 74 03          JZ   SD1               ; CONTINUE IF NOT
09A5 E9 07EA R      JMP  SHUT_8           ; GO HALT IF YES
09A8 C3              RET
;
;----- CAUSE A SHUTDOWN
;
09A9 B0 20          SD2: MOV  AL,20H          ; <<<<<<<<<<<<<<<<<<<<<<<<<<<<
09AB E6 80          OUT  MFG_PORT,AL     ; <<<<<<<<<<<<<<<<<<<<<<<<<<<<
09AD E9 0000 E      JMP  PROC_SHUTDOWN   ; CAUSE A SHUTDOWN (RETURN VIA JMP
;-----
; RETURN 1 FROM SHUTDOWN
;-----
;
09B0 B0 21          SHUT1: MOV AL,21H         ; <<<<<<<<<<<<<<<<<<<<<<<<<<<<
09B2 E6 80          OUT  MFG_PORT,AL     ; <<<<<<<<<<<<<<<<<<<<<<<<<<<<
09B4 BC ---- R     MOV  SP,STACK        ; SET REAL MODE STACK
09B7 8E D4          MOV  SS,SP           ;
09B9 BC 0100 R     MOV  SP,OFFSET TOS  ;
;
09BC B8 ---- R     MOV  AX,DATA         ; SET UP THE REAL DATA AREA
09BF 8E D8          MOV  DS,AX           ;
;
;----- GET THE CONFIGURATION FROM CMOS
;
09C1 B0 8E          MOV  AL,DIAG_STATUS ; CHECK CMOS GOOD
09C3 E6 70          OUT  CMOS_PORT,AL   ;
09C5 EB 00          JMP  SHORT $+2       ;
09C7 E4 71          IN  AL,CMOS_PORT+1 ; GET THE STATUS
09C9 AB C0          TEST AL,0COFH       ;
09CB 74 03          JZ   M_OK            ; GO IF YES
09CD EB 77 90      JMP  BAD_MOS         ; GO IF NOT
09D0 BA ED          M_OK: MOV AH,AL        ; SAVE THE CMOS STATUS
09D2 B0 8E          MOV  AL,DIAG_STATUS ; ADDRESS THE DIAG STATUS
09D4 E6 70          OUT  CMOS_PORT,AL   ;
09D6 86 C4          XCHG AL,AH          ; RESTORE THE STATUS BYTE
09D8 24 0F          AND  AL,0DFH        ; CLEAR THE MIN CONFIG BIT
09DA E6 71          OUT  CMOS_PORT+1,AL ;
09DC B0 94          MOV  AL,C_EQUIP     ; GET THE EQUIPMENT BYTE
09DE EB 00          JMP  SHORT $+2       ;
09E0 E6 70          OUT  CMOS_PORT,AL   ;
09E2 EB 00          JMP  SHORT $+2       ; IO DELAY
09E4 E4 71          IN  AL,CMOS_PORT+1 ;
;
;----- INSURE CONFIGURATION HAS CORRECT VIDEO TYPE
;
09E6 8A ED          MOV  AH,AL           ; SAVE VIDEO TYPE
09E8 AB 30          TEST AL,030H        ; ANY VIDEO?
09EA 75 2E          JNZ  MOS_OK_1        ; CONTINUE
09EC E8 09FB R     CALL CHK_VIDEO       ; INSURE VIDEO ROM PRESENT
09EF 74 4A          JZ   MOS_OK          ; CONTINUE
;
09F1 F6 06 0012 R 20   TEST MFG_TST,MFG_JMP ; EXCEPT IF MFG JUMPER IS INSTALLED
09F6 74 7A          JZ   NORMAL_CONFIG  ; GO IF INSTALLED
;
09F8 EB 4C 90      JMP  BAD_MOS         ; GO DEFAULT
;----- ROUTINE CHECK FOR VIDEO ROM PRESENT
;
09FB B9 C000        CHK_VIDEO: MOV CX,0C000H     ; START OF IO ROM
09FB B9 C000        CHK_VIDEO01:
09FE 50          PUSH AX             ; SAVE THE CONFIG
09FF 1E          PUSH DS            ; SAVE THE DATA SEGMENT
0A00 8E D9      MOV  DS,CX         ;
0A02 2B 0B      SUB  BX,BX         ; GET THE FIRST 2 LOCATIONS
0A04 8B 07      MOV  AX,[BX]      ;
0A06 1F          POP  DS            ; RESTORE DATA SEG AND BUS SETTLE
0A07 3D AA55    CMP  AX,0AA55H    ; IS THE VIDEO ROM PRESENT?
0A0A 58          POP  AX           ; GET THE CONFIG
0A0B 74 0C          JZ   CHK_VIDEO2   ; GO IF VIDEO ROM INSTALLED
0A0D 81 C1 0080  ADD  CX,080H     ; POINT TO NEXT 2K BLOCK
0A11 81 F9 C800  CMP  CX,0C800H   ; TOP OF VIDEO ROM AREA YET?
0A15 7C E7      JLT  CHK_VIDEO01 ; TRY AGAIN
0A17 23 09      AND  CX,CX       ; SET NON ZERO FLAG
0A19          CHK_VIDEO02:
0A19 C3          RET              ; RETURN TO CALLER
;
;----- CMOS VIDEO BITS NON ZERO (CHECK FOR PRIMARY DISPLAY AND NO VIDEO ROM)
;
0A1A          MOS_OK_1:
0A1A E8 09FB R     CALL CHK_VIDEO     ; IS THE VIDEO ROM INSTALLED?
0A1D 74 27          JZ   BAD_MOS      ; WRONG CONFIGURATION IN CONFIG BYTE
;
0A1F 8A C4          MOV  AL,AH         ; RESTORE CONFIGURATION
0A21 F6 06 0012 R 40  TEST MFG_TST,DSP_JMP ; CHECK FOR DISPLAY JUMPER
0A26 74 0B          JZ   MOS_OK_2      ; GO IF COLOR CARD IS PRIMARY DISPLAY
;----- MONO CARD IS PRIMARY DISPLAY (NO JUMPER INSTALLED)
;
0A28 24 30          AND  AL,30H        ; INSURE MONO IS PRIMARY
0A2A 3C 30          CMP  AL,30H        ; CONFIG OK?
0A2C 75 18          JNZ  BAD_MOS      ; GO IF NOT
0A2E 8A C4          MOV  AL,AH         ; RESTORE CONFIGURATION
0A30 EB 09 90      JMP  MOS_OK        ; USE THE CONFIG BYTE FOR CRT
;----- COLOR CARD
;
0A33          MOS_OK_2:
0A33 24 30          AND  AL,30H        ; STRIP UNWANTED BITS
0A35 3C 30          CMP  AL,30H        ; MUST NOT BE MONO WITH JUMPER INSTALLED
0A37 8A C4          MOV  AL,AH         ; RESTORE CONFIGURATION
0A39 74 0B          JZ   BAD_MOS      ; GO IF YES
;----- CONFIGURATION MUST HAVE AT LEAST ONE DISKETTE
;
0A3B A8 01          MOS_OK: TEST AL,01H      ; MUST HAVE AT LEAST ON DISKETTE
0A3D 75 33          JNZ  NORMAL_CONFIG ; GO SET CONFIGURATION IF OK
0A3F F6 06 0012 R 20  TEST MFG_TST,MFG_JMP ; EXCEPT IF MFG JUMPER IS INSTALLED
0A44 74 2C          JZ   NORMAL_CONFIG ; GO IF INSTALLED

```

SECTION 5

```

;----- MINIMUM CONFIG WITH BAD CMOS OR NON VALID VIDEO
BAD_MOS:
MOV AL,DIAG STATUS ; GET THE DIAGNOSTIC STATUS
OUT CMOS_PORT,AL ;
JMP SHORT S+2 ;
IN AL,CMOS_PORT+1 ;
TEST AL,000H ; WAS THE BATTERY DEFECTIVE OR BAD CKSUM
JNZ BAD_MOS1 ; GO IF YES
XCHG AL,AH ; SAVE THE STATUS
MOV AL,DIAG STATUS ; CHECK CMOS GOOD
OUT CMOS_PORT,AL ;
JMP SHORT S+2 ;
XCHG AL,AH ; RESTORE THE STATUS
OR AL,20H ; SET THE MIN CONFIG FLAG

0A5E E6 71 OUT CMOS_PORT+1,AL ; STORE THE STATUS
0A60 E8 09FB R BAD_MOS1: CALL CHK_VIDEO ; CHECK FOR VIDEO ROM
0A63 B0 01 MOV MOV AL,01H ; DISKETTE ONLY
0A65 74 08 JZ NORMAL_CONFIG ; GO IF VIDEO ROM PRESENT

0A67 F6 06 0012 R 40 TEST MFG_TST,DSP_JMP ; CHECK FOR DISPLAY JUMPER
0A6C B0 11 MOV MOV AL,11H ; DEFAULT TO 40X25 COLOR
0A6E 74 02 JZ NORMAL_CONFIG ; GO IF JUMPER IS INSTALLED

0A70 B0 31 MOV AL,31H ; DISKETTE / BW CRT BOX25
;-----
; CONFIGURATION AND MFG. MODE
;-----
0A72 NORMAL_CONFIG:
TEST MFG_TST,MFG_JMP ; IS THE MANUFACTURING JUMPER INSTALLED
JNZ NORM1 ; GO IF NOT
AND AL,03EH ; STRIP DISKETTE FOR MFG TEST

0A78 2A E4 NORM1: SUB AH,AH ;
0A7D A3 0010 R MOV MOV EQUIP_FLAG,AX ; SAVE SWITCH INFO
0A80 B1 3E 0072 R 1234 CMP RESET_FLAG,1234H ; BYPASS IF SOFT RESET
0A86 74 2C JZ E6

;----- GET THE FIRST SELF TEST RESULTS FROM KEYBOARD
0A88 B0 60 MOV AL,60H ; ENABLE KEYBOARD
0A8A E8 0405 R CALL CB042 ; ISSUE WRITE BYTE COMMAND
0A8D B0 4D MOV AL,4DH ; ENABLE OUT BUFF FULL INT
; SYS FLAG - PC1 COMP - INH OVERRIDE
; ENABLE KEYBOARD

0A8F E6 60 OUT PORT_A,AL ;

0A91 2B C9 SUB CX,CX ; WAIT FOR COMMAND ACCEPTED
0A93 E8 040A R CALL C42_1 ;

0A96 B9 7FFF MOV CX,07FFFH ; SET LOOP COUNT FOR APPROX 100 MS
; TO RESPOND

0A99 E4 64 TST6: IN AL,STATUS_PORT ; WAIT FOR OUTPUT BUFF FULL
0A9B A8 01 TEST AL,OUT_BUF_FULL ;
0A9D E1 FA LOOPZ TST6 ; TRY AGAIN IF NOT

0A9F 9C PUSHF ; SAVE FLAGS
0AAD B0 AD MOV AL,D1S_KBD ; DISABLE KEYBOARD
0AA2 E8 0405 R CALL CB042 ; ISSUE THE COMMAND
0AA5 9D POPF ; RESTORE FLAGS
0AA6 74 0C JZ E6 ; CONTINUE WITHOUT RESULTS
0AAB E4 60 IN AL,PORT_A ; GET INPUT FROM KEY BOARD
0AAA A2 0072 R MOV BYTE PTR RESET_FLAG,AL ; TEMP SAVE FOR AA RECEIVED

;----- CHECK FOR MFG REQUEST
0AAD 3C 65 CMP AL,065H ; LOAD MFG. TEST REQUEST?
0AAF 75 03 JNE E6 ;
0AB1 E9 002C R JMP MFG_BOOT ; GO TO BOOTSTRAP IF SO
;-----
; TEST_14
; INITIALIZE AND START CRT CONTROLLER (6845)
; TEST VIDEO READ/WRITE STORAGE.
; DESCRIPTION
; RESET THE VIDEO ENABLE SIGNAL.
; SELECT ALPHANUMERIC MODE, 40 = 25, B & W.
; READ/WRITE DATA PATTERNS TO STG. CHECK STG
; ADDRESSABILITY.
; ERROR = 1 LONG AND 2 SHORT BEEPS
;-----
0AB4 A1 0010 R E6: MOV AX,EQUIP_FLAG ; GET SENSE INFO
0AB4 50 PUSH AX ; SAVE IT
0AB7 B0 30 MOV AL,30H
0ABA A3 0010 R MOV EQUIP_FLAG,AX
0ABD 2A E4 SUB AH,AH
0ABF CD 10 INT INT_VIDEO ; SEND INIT TO B/W CARD
0AC1 B0 20 MOV AL,20H
0AC3 A3 0010 R MOV EQUIP_FLAG,AX
0AC6 2A E4 SUB AH,AH ; AND INIT COLOR CARD
0AC8 CD 10 INT INT_VIDEO
0ACA BB 0001 MOV AX,0001H ; SET COLOR 40X25 MODE
0ACD CD 10 INT INT_VIDEO
0ACF 58 POP AX ; RECOVER REAL SWITCH INFO
0AD0 A3 0010 R MOV EQUIP_FLAG,AX ; RESTORE IT
0AD3 24 30 AND AL,30H ; ISOLATE VIDEO SWS
0AD5 75 12 JNZ E7 ; VIDEO SWS SET TO 0?
0AD7 1E PUSH DS ; SAVE THE DATA SEGMENT
0ADB 50 PUSH AX ; SET DATA SEGMENT TO 0
0AD9 2B C0 SUB AX,AX
0ADB 8E D8 MOV DS,AX
0ADD BF 0040 R MOV D1,OFFSET VIDEO_INT ; SET INT 10H TO DUMMY
0ADE C7 05 0000 E MOV WORD PTR [D1],OFFSET DUMMY ; RETURN ; RETURN IF NO VIDEO CARD
0AE4 58 POP AX ; RESTORE REGISTERS
0AE5 1F POP DS
0AE6 E9 0868 R JMP E18_1 ; BYPASS VIDEO TEST
0AE9 E7: TEST VIDEO:
0AE9 3C 30 CMP AL,30H ; B/W CARD ATTACHED?
0AEB 74 08 JE E8 ; YES - SET MODE FOR B/W CARD
0AED FE C4 INC AH ; SET COLOR MODE FOR COLOR CD
0AEF 3C 20 CMP AL,20H ; 80X25 MODE SELECTED?
0AF1 75 02 JNE E8 ; NO - SET MODE FOR 40X25
0AF3 B4 03 MOV AH,3 ; SET MODE FOR 80X25
0AF5 B6 E0 XCHG AH,AL ; SET MODE
0AF7 50 PUSH AX ; SAVE VIDEO MODE ON STACK
0AF8 2A E4 SUB AH,AH ; INITIALIZE TO ALPHANUMERIC MD
0AFA CD 10 INT INT_VIDEO ; CALL VIDEO_IO
0AFC 58 POP AX ; RESTORE VIDEO SENSE SWS IN AH
0AFD 50 PUSH AX ; RESAVE VALUE
0AFE BB B000 MOV BX,0B000H ; BEG VIDEO RAM ADDR B/W CD
0B01 BA 0388 MOV DX,388H ; MODE REG FOR B/W

```



```

OBCB 2B DB          SUB    BX,BX          ; TO THE FIRST LOCATION
OBCD 89 07          MOV    [BX],AX          ;
OBCE EB 00          JMP    SHORT S+2        ; ALLOW BUS TO SETTLE
OBD1 8B 07          MOV    AX,[BX]         ; READ THE FIRST LOCATION
OBD3 3D AA55        CMP    AX,0AA55H       ; IS THE MONO VIDEO CARD THERE?
OBD6 1F             POP    DS              ; RESTORE THE DATA SEGMENT
OBD7 75 56          JNZ   E17_3           ; GO IF NOT
OBD9 81 0E 0010 R 0030 OR    EQUIP_FLAG,30H   ; TURN ON MONO BITS IN EQUIP FLAG
OBDF A1 0010 R     MOV    AX,EQUIP_FLAG   ; ENABLE VIDEO
OBE2 2A E4          SUB    AH,AH           ;
OBE4 CD 10          INT    INT_VIDEO      ;
OBE6 EB 35 90       JMP    E17_1          ; CONTINUE

;----- MONO FAILED TRY COLOR

OBE9 80 01          MOV    AL,01H          ; SET MODE COLOR 40X25
OBE9 B0 01          SUB    AH,AH           ;
OBE8 2A E4          INT    INT_VIDEO      ;
OBE9 CD 10          MOV    DX,3D8H        ; DISABLE COLOR
OBEF BA 03D8       MOV    AL,0           ;
OBF2 B0 00          OUT    DX,AL          ; OUTPUT THE DISABLE
OBF4 EE            MOV    BX,0B800H      ; CHECK FOR COLOR VIDEO RAM
OBF5 BB B800       MOV    DS,BX          ;
OBF6 8E DB         MOV    AX,0AA55H     ; WRITE AN AA55
OBF8 B8 AA55       MOV    SUB BX,BX      ; TO THE FIRST LOCATION
OBF9 2B DB         MOV    [BX],AX        ;
OBF9 89 07         JMP    SHORT S+2      ; ALLOW BUS TO SETTLE
OC01 EB 00         MOV    AX,[BX]        ; READ THE FIRST LOCATION
OC03 8B 07         CMP    AX,0AA55H     ; IS THE COLOR VIDEO CARD THERE?
OC05 3D AA55       POP    DS              ; RESTORE THE DATA SEGMENT
OC08 1F             JNZ   E17_3           ; GO IF NOT
OC09 79 24         AND    EQUIP_FLAG,OFFCFH ; TURN OFF VIDEO BITS
OC0B 81 26 0010 R FFCF OR    EQUIP_FLAG,10H  ; SET COLOR 40X24
OC11 81 0E 0010 R 0010 MOV    AL,01H         ;
OC17 B0 01         SUB    AH,AH           ;
OC19 2A E4          INT    INT_VIDEO      ;
OC1B CD 10          E17_1:
OC1D 58             POP    AX              ; SET NEW VIDEO TYPE ON STACK
OC1E A1 0010 R     MOV    AX,EQUIP_FLAG  ;
OC21 24 30         AND    AL,30H         ;
OC23 3C 30         CMP    AL,30H         ; IS IT THE B/W?
OC25 2A C0         SUB    AL,AL          ;
OC27 74 02         JZ    E17_2           ; GO IF YES
OC29 FE C0         INC    AL              ; INIT FOR 40X25
OC2B 50             PUSH   AX              ;
OC2C E9 0B63 R     E17_4: JMP    E18            ;

;----- BOTH VIDEO CARDS FAILED SET DUMMY RETURN IF RETRACE FALIURE

OC2F 1E             PUSH   DS              ;
OC30 2B C0         SUB    AX,AX          ; SET DS SEGMENT TO 0
OC32 8E D8         MOV    DS,AX          ;
OC34 BF 0040 R     MOV    DI,OFFSET VIDEO_INT ; SET INT 10H TO DUMMY
OC37 C7 05 0000 E MOV    WORD PTR [DI],OFFSET DUMMY_RETURN ; RETURN IF NO VIDEO CARD
OC38 1F             POP    DS              ;
OC3C E9 0B68 R     JMP    E18_1          ; BYPASS REST OF VIDEO TEST
OC3F 83             POST1  ENDP
OC3F 83             CODE    ENDS
OC3F 83             END

```



```

0197 E6 87                OUT    DMA_PAGE+6,AL                ; SAVE WHICH CHECK TO USE
;----- PRINT 64 K BYTES OK

0199 88 0040             E20A:  MOV    AX,16*4                ; STARTING AMT. OF MEMORY OK
019C 50                   PUSH   AX                    ; SAVE MEMORY OK SIZE
019D E9 0347 R           JMP     PRT_SIZ              ; POST MESSAGE
;----- IS CMOS GOOD?

01A0 80 8E             E20B:  MOV    AL,DIAG_STATUS          ; DETERMINE THE CONDITION OF CMOS
01A2 E6 70             MOV    CMOS_PORT,AL         ;
01A4 EB 00             JMP     SHORT $+2            ; 10 DELAY
01A6 E4 71             IN     AL,CMOS_PORT+1       ; GET THE CMOS STATUS
01A8 50                   PUSH   AX                    ; SAVE CMOS STATUS
;----- GET THE MEMORY SIZE DETERMINED (PREPARE BX FOR BAD CMOS)

01A9 80 B1             MOV    AL,M_SIZE_HI         ; GET THE HIGH BYTE
01AB E6 70             MOV    CMOS_PORT,AL         ;
01AD EB 00             JMP     SHORT $+2            ; 10 DELAY
01AF E4 71             IN     AL,CMOS_PORT+1       ; HIGH BYTE
01B1 86 E0             XCHG  AH,AL                 ; SAVE HIGH BYTE
01B3 80 B0             MOV    AL,M_SIZE_LO         ; GET LOW BYTE
01B5 E6 70             OUT    CMOS_PORT,AL         ;
01B7 EB 00             JMP     SHORT $+2            ; 10 DELAY
01B9 E4 71             IN     AL,CMOS_PORT+1       ; LOW BYTE
01BB 88 1E 0013 R     MOV    BX,MEMORY_SIZE       ; PRE LOAD THE MEMORY SIZE
01BF 03 D8             ADD    BX,AX                 ; SET TOTAL MEMORY SIZE
01C1 89 1E 0017 R     MOV    WORD PTR KB_FLAG,BX  ; SAVE THE TOTAL SIZE
01C5 58                   POP     AX                    ; RESTORE CMOS STATUS

01C6 A8 C0             TEST   AL,0C0H              ; CMOS OK?
01C8 74 03             JZ     E20B0                 ; GO IF YES
01CA E9 026E R           JMP     E20C                 ; DEFAULT IF NOT
01CD

E20B0:                GET THE BASE 0->640K MEMORY SIZE FROM CONFIG IN CMOS
;-----

01CD 80 96             MOV    AL,M1_SIZE_HI        ; GET THE HIGH BYTE
01CF E6 70             OUT    CMOS_PORT,AL         ;
01D1 EB 00             JMP     SHORT $+2            ; 10 DELAY
01D3 E4 71             IN     AL,CMOS_PORT+1       ; HIGH BYTE
01D5 86 E0             XCHG  AH,AL                 ; SAVE HIGH BYTE
01D7 80 95             MOV    AL,M1_SIZE_LO        ; GET LOW BYTE
01D9 E6 70             OUT    CMOS_PORT,AL         ;
01DB EB 00             JMP     SHORT $+2            ; 10 DELAY
01DD E4 71             IN     AL,CMOS_PORT+1       ; LOW BYTE
01DF 39 06 0013 R     CMP    MEMORY_SIZE,AX        ; IS MEMORY SIZE GREATER THAN CONFIG?
01E3 74 1C             JZ     E20B1                 ; GO IF EQUAL
;----- SET MEMERY SIZE DETERMINE NOT EQUAL TO CONFIG

01E5 50                   PUSH   AX                    ; SAVE AX
01E6 80 8E             MOV    AL,DIAG_STATUS          ;
01E8 E6 70             MOV    CMOS_PORT,AL         ; ADDRESS THE STATUS BYTE
01EA EB 00             JMP     SHORT $+2            ; 10 DELAY
01EC E4 71             IN     AL,CMOS_PORT+1       ; GET THE STATUS
01EE 0C 10             OR     AL,W_MEM_SIZE         ; SET CMOS FLAG
01F0 86 C4             XCHG  AH                     ; SAVE AL
01F2 80 8E             MOV    AL,DIAG_STATUS          ;
01F4 E6 70             OUT    CMOS_PORT,AL         ;
01F6 86 C4             XCHG  AL,AH                 ; RESTORE AL
01F8 EB 00             JMP     SHORT $+2            ; 10 DELAY
01FA E6 71             OUT    CMOS_PORT+1,AL       ;
01FC 58                   POP     AX                    ; RESTORE AX
01FD 39 06 0013 R     CMP    MEMORY_SIZE,AX        ; IS MEMORY SIZE GREATER THAN CONFIG?
0201 77 6B             JJA    E20C                 ; DEFAULT TO MEM SIZE DET IF YES
0203 88 D8             MOV    BX,AX                 ; SET BASE MEMORY SIZE
0205 30 0201          CMP    AX,513                ; CHECK IF BASE RAM LESS 512K
0208 72 16             JB     E20B1                 ; GO IF YES
020A 80 B3             MOV    AL,INFO_STATUS        ; SET 640K BASE RAM BIT
020C E6 70             OUT    CMOS_PORT,AL         ;
020E EB 00             JMP     SHORT $+2            ; 10 DELAY
0210 E4 71             IN     AL,CMOS_PORT+1       ; GET THE CURRENT STATUS
0212 0C 80             OR     AL,M_640K             ; TURN ON 640K BIT IF NOT ALREADY ON
0214 86 C4             XCHG  AL,AH                 ; SAVE THE CURRENT DIAG STATUS
0216 80 B3             MOV    AL,INFO_STATUS        ;
0218 E6 70             OUT    CMOS_PORT,AL         ; ADDR THE STATUS BYTE
021A 86 C4             XCHG  AL,AH                 ; RESTORE THE STATUS
021C EB 00             JMP     SHORT $+2            ; 10 DELAY
021E E6 71             OUT    CMOS_PORT+1,AL       ;
;----- CHECK MEMORY SIZE ABOVE 640K FROM CONFIG

No_640:                ABOVE 640K SIZE FROM MEMORY SIZE DETERMINE
;----- CX=CONFIG AX=MEMORY SIZE DETERMINE

0220 80 98             MOV    AL,M2_SIZE_HI        ; GET THE HIGH BYTE
0222 E6 70             OUT    CMOS_PORT,AL         ;
0224 EB 00             JMP     SHORT $+2            ; 10 DELAY
0226 E4 71             IN     AL,CMOS_PORT+1       ; HIGH BYTE
0228 86 E0             XCHG  AH,AL                 ; SAVE HIGH BYTE
022A 80 97             MOV    AL,M2_SIZE_LO        ; GET LOW BYTE
022C E6 70             OUT    CMOS_PORT,AL         ;
022E EB 00             JMP     SHORT $+2            ; 10 DELAY
0230 E4 71             IN     AL,CMOS_PORT+1       ; LOW BYTE
0232 88 C7             MOV    CX,AX                 ; SAVE THE ABOVE 640K RAM SIZE
;-----

0234 80 B1             MOV    AL,M_SIZE_HI         ; GET THE HIGH BYTE
0236 E6 70             OUT    CMOS_PORT,AL         ;
0238 EB 00             JMP     SHORT $+2            ; 10 DELAY
023A E4 71             IN     AL,CMOS_PORT+1       ; HIGH BYTE
023C 86 E0             XCHG  AH,AL                 ; SAVE HIGH BYTE
023E 80 B0             MOV    AL,M_SIZE_LO         ; GET LOW BYTE
0240 E6 70             OUT    CMOS_PORT,AL         ;
0242 EB 00             JMP     SHORT $+2            ; 10 DELAY
0244 E4 71             IN     AL,CMOS_PORT+1       ; LOW BYTE
;----- WHICH IS GREATER

0246 38 C8             AX=MEMORY SIZE DETERMINE CX=CONFIG (ABOVE 640) BX=SIZE (BELOW 640)
0248 74 18             JZ     SET_MEM1              ; IS CONFIG EQUAL TO DETERMINED?
;----- SET MEMERY SIZE DETERMINE NOT EQUAL TO CONFIG

024A 50                   PUSH   AX                    ; SAVE AX
024B 80 8E             MOV    AL,DIAG_STATUS          ;
024D E6 70             MOV    CMOS_PORT,AL         ; ADDRESS THE STATUS BYTE
024F EB 00             JMP     SHORT $+2            ; 10 DELAY
0251 E4 71             IN     AL,CMOS_PORT+1       ; GET THE STATUS
0253 0C 10             OR     AL,W_MEM_SIZE         ; SET CMOS FLAG
0255 86 C4             XCHG  AH                     ; SAVE AL
0257 80 8E             MOV    AL,DIAG_STATUS          ;
0259 E6 70             MOV    CMOS_PORT,AL         ; RESTORE AL
025B 86 C4             XCHG  AL,AH                 ;
025D EB 00             JMP     SHORT $+2            ; 10 DELAY
025F E6 71             OUT    CMOS_PORT+1,AL       ;
0261 58                   POP     AX                    ; RESTORE AX

0262

SET_MEM1:

```



```

;----- CLEAR IO CH CHK OR R/W PAR CHK
048F 2B F6          SUB     S1,S1          ; WRITE TO FAILING BLOCK
0491 AB 61          STOSW  IN              ;
0492 E4 61          IN       AL,PORT_B   ;
0494 0C 00          OR      AL,RAM_PAR_OFF ; TOGGLE IO/PAR CHECK ENABLE
0496 EB 00          JMP     SHORT $+2      ; IO DELAY
0498 E6 61          OUT     PORT_B,AL     ;
049A 24 F3          AND     AL,RAM_PAR_ON  ;
049C EB 00          JMP     SHORT $+2      ; IO DELAY
049E E6 61          OUT     PORT_B,AL     ;
;=====
;----- SET MEMORY SIZE
;=====
04A0 B8 0018        MOV     AX,RSDA_PTR    ; SET THE DATA SEGMENT
04A3 8E D8          MOV     DS,AX          ; IN PROTECTED MODE
;----- GET THE DIAG_STATUS FROM CMOS
04A5 B0 8E          MOV     AL,DIAG_STATUS ;
04A7 E6 70          OUT     CMOS_PORT,AL  ;
04A9 EB 00          JMP     SHORT $+2      ; IO DELAY
04AB E4 71          IN     AL,CMOS_PORT+1 ;
04AD 8A D8          MOV     BL,AL          ; SAVE THE STATUS BYTE
04AF B0 83          MOV     AL,INFO_STATUS ;
04B1 E6 70          OUT     CMOS_PORT,AL  ;
04B3 EB 00          JMP     SHORT $+2      ; IO DELAY
04B5 E4 71          IN     AL,CMOS_PORT+1 ;
04B7 8A F8          MOV     BH,AL          ; SAVE THE STATUS BYTE
;----- GET THE LAST OF GOOD MEMORY
04B9 59              POP     CX              ;
04BA 58              POP     AX              ; GET THE LAST OF GOOD MEMORY
04BB 8B CB          MOV     CX,AX          ; SAVE IT
;----- BELOW 512K?
04BD 3D 0200        CMP     AX,512         ; LAST GOOD MEMORY BELOW 512K?
04C0 72 39          JB     M3              ; GO IF YES
;----- BELOW 640K?
04C2 3D 0280        CMP     AX,640         ; LAST GOOD MEMORY BELOW 640K?
04C5 72 11          JB     M1              ; GO IF YES
;----- 640K UP ERROR
04C7 F6 C7 80        TEST    BH,M640K      ; IS BASE RAM 640K
04CA 75 06          JNZ    M0              ;
04CC 2D 0200        SUB     AX,512         ; 512K BASE RAM
04CF EB 0F 90        JMP     M2              ;
04D2 2D 0280        SUB     AX,640         ; 640K BASE RAM
04D5 EB 09 90        JMP     M2              ;
;----- 512K to 640K ERROR
04D8 F6 C7 80        M1:    TEST    BH,M640K      ; IS BASE RAM 640K?
04DB 75 1E          JNZ    M3              ; GO IF YES
04DD 2D 0200        SUB     AX,512         ; STRIP BASE RAM FROM IO RAM
;----- WRITE SIZE TO CMOS
04E0 8B C8          M2:    MOV     CX,AX          ; SAVE ADJUSTED MEMORY SIZE
04E2 B0 B1          MOV     AL,M_SIZE_H1  ;
04E4 E6 70          OUT     CMOS_PORT,AL  ;
04E6 8A C5          MOV     AL,CH          ; GET THE HIGH BYTE MEMORY SIZE
04E8 EB 00          JMP     SHORT $+2      ; IO DELAY
04EA E6 71          OUT     CMOS_PORT+1,AL ; WRITE IT
04EC B0 B0          MOV     AL,M_SIZE_LO  ; DO THE LOW BYTE
04EE EB 00          JMP     SHORT $+2      ;
04F0 E6 70          OUT     CMOS_PORT,AL  ;
04F2 8A C1          MOV     AL,CL          ; GET THE LOW BYTE
04F4 EB 00          JMP     SHORT $+2      ; IO DELAY
04F6 E6 71          OUT     CMOS_PORT+1,AL ; WRITE IT
04F8 EB 04 90        JMP     M4              ; CONTINUE
;----- SET BASE MEMORY SIZE
04FB A3 0013 R       M3:    MOV     MEMORY_SIZE,AX ; TO INDICATE HOW MUCH MEM WORKING
;----- SET SHUTDOWN 3
04FE B0 8F          M4:    MOV     AL,SHUT_DOWN ; ADDR FOR SHUTDOWN RETURN
0500 E6 70          OUT     CMOS_PORT,AL  ;
0502 B0 03          MOV     AL,3           ; SET RETURN 3
0504 EB 00          JMP     SHORT $+2      ; IO DELAY
0506 E6 71          OUT     CMOS_PORT+1,AL ;
;----- SHUTDOWN
0508 E9 0000 E       JMP     PROC_SHUTDOWN  ;
PAGE
;----- ENTRY 3 FROM PROCESSOR SHUTDOWN
;-----
;----- MEMORY ERROR REPORTING
;-----
; DESCRIPTION FOR ERRORS 201(CMP ERROR or PARITY)
; or 202(ADDRESS LINE 0-15 ERROR)
; R/W MEMORY ERRORS WILL BE REPORTED AS FOLLOWS
;
; AABBC DDEE 201(or 202)
; AA=HIGH BYTE OF 24 BIT ADDRESS
; BB=MIDDLE BYTE OF 24 BIT ADDRESS
; CC=LOW BYTE OF 24 BIT ADDRESS
; DD=HIGH BYTE OF XOR FAILING BIT PATTERN
; EE=LOW BYTE OF XOR FAILING BIT PATTERN
;
; DESCRIPTION FOR ERROR 202 (ADDRESS LINE 00-15)
; A WORD OF FFFF IS WRITTEN AT THE FIRST WORD AND LAST WORD
; OF EACH 64K BLOCK WITH ZEROS AT ALL OTHER LOCATIONS OF THE
; BLOCK. A SCAN OF THE BLOCK IS MADE TO INSURE ADDRESS LINE
; 0-15 ARE FUNCTIONING.
;
; DESCRIPTION FOR ERROR 203 (ADDRESS LINE 16-23)
; AT THE LAST PASS OF THE STORAGE TEST, FOR EACH BLOCK OF
; 64K, THE CURRENT STORAGE SIZE (10) IS WRITTEN AT THE FIRST
; WORD OF EACH BLOCK. IT IS USED TO DETERMINE ADDRESSING
; FAILURES.
;
; AABBC DDEE 203
; SAME AS ABOVE EXCEPT FOR DDEE
;

```

0000

```

C INCLUDE SEGMENT_SRC
C CODE SEGMENT BYTE PUBLIC
C

```

```

EXTRN ROM_ERR:NEAR
;-----
; ROS CHECKSUM SUBROUTINE
;-----

```

```

0000 ASSUME CS:CODE, DS:ABS0
0000 POST3: ROS_CHECKSUM PROC NEAR ; NEXT ROS_MODULE
0000 SUB CX,CX ; NUMBER OF BYTES TO ADD IS 64K
0002 ROS_CHECKSUM_CNT: XOR AL,AL ; ENTRY FOR OPTIONAL ROS TEST
0004 C26:
0004 ADD AL,DS:[BX]
0006 INC BX ; POINT TO NEXT BYTE
0007 LOOP C26 ; ADD ALL BYTES IN ROS MODULE
0009 OR AL,AL ; SUM = 0?
000B RET
000C ROS_CHECKSUM ENDP

```

```

;-----
; BLINK LED PROCEDURE FOR MFG RUN-IN TESTS
; IF LED IS ON, TURN IT OFF. IF OFF, TURN ON.
;-----

```

```

000C BLINK_INT PROC NEAR
000D STI
000D PUSH AX ; SAVE AX REG CONTENTS
000E IN AL,MFG_PORT ; READ CURRENT VAL OF MFG_PORT
0010 MOV AH,AL
0012 NOT AL
0014 AND AL,01000000B ; FLIP ALL BITS
0016 AND AH,10111111B ; ISOLATE CONTROL BIT
0019 OR AL,AH ; MASK OUT OF ORIGINAL VAL
001B OUT MFG_PORT,AL ; OR NEW CONTROL BIT IN
001D MOV AL,EOI
001F OUT INTA00,AL
0021 POP AX ; RESTORE AX REG
0022 IRET
0023 BLINK_INT ENDP

```

```

;-----
; THIS ROUTINE CHECKSUMS OPTIONAL ROM MODULES AND
; IF CHECKSUM IS OK, CALLS INIT/TEST CODE IN MODULE
;-----

```

```

0023 ROM_CHECK PROC NEAR
0023 MOV AX,DATA ; POINT ES TO DATA AREA
0026 MOV ES,AX ; ZERO OUT AH
0028 SUB AH,AH ; GET LENGTH INDICATOR
002A MOV AL,[BX+2] ; MULTIPLY BY 512
002D MOV CL,09H
002F SHL AX,CL
0031 MOV CX,AX ; SET COUNT
0033 PUSH CX ; SAVE COUNT
0034 MOV CX,4 ; ADJUST
0037 SHR AX,CL ; SET POINTER TO NEXT MODULE
0039 ADD DX,AX ; RETRIEVE COUNT
003B POP CX ; DO CHECKSUM
003C CALL ROS_CHECKSUM_CNT
003F JZ ROM_CHECK_1 ; POST CHECKSUM ERROR
0041 CALL ROM_ERR ; AND EXIT
0044 EB 14 90
0047 ROM_CHECK_1:
0047 PUSH DX ; SAVE POINTER
0048 MOV ES:10_ROM_INIT,0003H ; LOAD OFFSET
004F MOV ES:10_ROM_SEG,DS ; LOAD SEGMENT
0054 CALL DWORD PTR ES:10_ROM_INIT ; CALL INIT./TEST ROUTINE
0059 POP DX
005A ROM_CHECK_END:
005A RET ; RETURN TO CALLER
005B ROM_CHECK ENDP

```

```

;-----
; CONVERT AND PRINT ASCII CODE
;-----

```

```

; AL MUST CONTAIN NUMBER TO BE CONVERTED.
; AX AND BX DESTROYED.
;-----

```

```

005B XPC_BYTE PROC NEAR
005B PUSH AX ; SAVE FOR LOW NIBBLE DISPLAY
005C MOV CL,4 ; SHIFT COUNT
005E SHR AL,CL ; NIBBLE SWAP
0060 CALL XLAT_PR ; DO THE HIGH NIBBLE DISPLAY
0063 POP AX ; RECOVER THE NIBBLE
0064 AND AL,0FH ; ISOLATE TO LOW NIBBLE
0066 XLAT_PR PROC NEAR ; FALL INTO LOW NIBBLE CONVERSION
0066 ADD AL,090H ; CONVERT 00-0F TO ASCII CHARACTER
0068 DAA ; ADD FIRST CONVERSION FACTOR
0069 ADC AL,040H ; ADJUST FOR NUMERIC AND ALPHA RANGE
006B DAA ; ADD CONVERSION AND ADJUST LOW NIBBLE
006C AND AL,0FH ; ADJUST HIGH NIBBLE TO ASCII RANGE
006C PRT_HEX PROC NEAR
006C MOV AH,14 ; DISPLAY CHARACTER IN AL
006E MOV BH,0
0070 INT 10H ; CALL VIDEO_IO
0072 RET
0073 PRT_HEX ENDP
0073 XLAT_PR ENDP
0073 XPC_BYTE ENDP

```

```

;-----
; PUT CHARACTER TO THE CRT FOR TEST.11 IN
; PROTECTED MODE
;-----

```

```

; AL=ASCII CHARACTER DI=CRT BUFFER POSITION
;-----

```

```

0073 PROT_PRT_HEX PROC NEAR
0073 PUSH DS ; SAVE CURRENT SEGMENT REGS
0074 PUSH BX

```

```

;----- B/W VIDEO CARD

```

```

0075 MOV BX,C_BWCRT_PTR ;
0078 MOV DS,BX ; SET DS TO BW CRT BUFFER
007A CALL PROT_PRT ; GO PRINT CHARACTER

```

```

;----- COMPATIBLE COLOR
007D BB 0028      MOV    BX,C_CCR_T_PTR      ; SET DS TO COMPATIBLE COLOR RAM
0080 8E DB        MOV    DS,BX      ;
0082 E8 0098 R    CALL   PROT_PRT        ;
;----- ENHANCED COLOR
0085 BB 0030      MOV    BX,E_CCR_T_PTR      ; ENHANCED COLOR
0088 8E DB        MOV    DS,BX      ;
008A E8 0098 R    CALL   PROT_PRT        ;
008D BB 0038      MOV    BX,E_CCR_T_PTR2    ;
0090 8E DB        MOV    DS,BX      ; ENHANCED COLOR PTR HI 64K
0092 E8 0098 R    CALL   PROT_PRT        ;
0095 5B          POP    BX      ;
0096 1F          POP    DS      ;
0097 C3          RET          ;
PROT_PRT:
;
0098             PUSH   DI          ; SAVE DISPLACEMENT
0099 D1 C7        ROL    DI,1        ; MULT #2
009B 8B 05        MOV    DS:[DI],AL    ; WRITE TO CRT BUFFER
009D 5F          POP    DI          ; RESTORE DISPLACEMENT
009E C3          RET          ;
PROT_PRT_HEX    ENDP
;
PROC_SHUTDOWN  PROC
009F B0 FE        MOV    AL,SHUT_CMD      ; SHUTDOWN COMMAND
00A1 E6 64        OUT    STATUS_PORT,AL    ;
00A3 F4          HLT          ;
00A4 EB FD        JMP     PROC_S        ;
PROC_SHUTDOWN  ENDP
00A6             CODE
00A6             ENDS
00A6             END

```

0000

C INCLUDE SEGMENT.SRC
C CODE SEGMENT BYTE PUBLIC

EXTRN PRT_HEX:NEAR
EXTRN XPC_BYTE:NEAR
EXTRN XM11_8042:NEAR
EXTRN OBF_02:NEAR
ASSUME CS:CODE,DS:ABS0
POST4:

0000

; THIS SUBROUTINE WILL PRINT A MESSAGE ON THE DISPLAY
; ENTRY REQUIREMENTS:
; S1 = OFFSET(ADDRESS) OF MESSAGE BUFFER
; CX = MESSAGE BYTE COUNT
; MAXIMUM MESSAGE LENGTH IS 36 CHARACTERS

0000
0009
0002
0005

E_MSG PROC NEAR
MOV BP,S1 ; SET BP NON-ZERO TO FLAG ERR
CALL P_MSG ; PRINT MESSAGE
PUSH DS

0006
0009
000C
000E
0010

ASSUME DS:DATA
CALL DDS
MOV AL,BYTE PTR EQUIP_FLAG ; LOOP/HALT ON ERROR
AND AL,01H ; SWITCH ON?
JNZ NOT_ON ; NO - RETURN

0010
0011
0014
0016

MFG_HALT:
CLI
MOV AL,MFG_ERR_FLAG ; YES - HALT SYSTEM
OUT MFG_PORT,AL ; RECOVER ERROR INDICATOR
HLT ; HALT SYS

0017
0018
0019

NOT_ON:
POP DS ; WRITE_MSG:
RET

0019
0019
0019
001C
001D

E_MSG ENDP
P_MSG PROC NEAR
G12A: MOV AL,CS:[S1] ; PUT CHAR IN AL
INC S1 ; POINT TO NEXT CHAR
PUSH AX ; SAVE PRINT CHAR

001E
0021
0022
0024
0026
0027

CALL PRT_HEX ; CALL VIDEO_IO
POP AX ; RECOVER PRINT CHAR
CMP AL,10 ; WAS IT LINE FEED?
JNE G12A ; NO,KEEP PRINTING STRING
RET

P_MSG ENDP

; INITIAL RELIABILITY TEST -- SUBROUTINES

ASSUME CS:CODE,DS:DATA

; SUBROUTINES FOR POWER ON DIAGNOSTICS

; THIS PROCEDURE WILL ISSUE ONE LONG TONE (3 SECS) AND ONE OR
; MORE SHORT TONES (1 SEC) TO INDICATE A FAILURE ON THE PLANAR
; BOARD, A BAD RAM MODULE, OR A PROBLEM WITH THE CRT.
; ENTRY PARAMETERS:
; DH = NUMBER OF LONG TONES TO BEEP
; DL = NUMBER OF SHORT TONES TO BEEP.

0027
0028
0029
002A
002D
002F

ERR_BEEP PROC NEAR
PUSHF ; SAVE FLAGS
CLI ; DISABLE SYSTEM INTERRUPTS
PUSH DS ; SAVE DS REG CONTENTS
CALL DDS

0031
0031
0033
0036
0038
003A
003C
0041
0043
0045

G1: MOV BL,6 ; ANY LONG ONES TO BEEP
CALL BL,6 ; NO, DO THE SHORT ONES
CALL BL,6 ; LONG BEEP;
CALL BL,6 ; COUNTER FOR BEEPS
CALL BL,6 ; DO THE BEEP

0036
0038
003A
003C
0041
0043
0045

G2: LOOP G2 ; DELAY BETWEEN BEEPS
DEC DH ; ANY MORE TO DO
JNZ G1 ; DO IT
CMP MFG_TST,1 ; MFG TEST MODE?
JNE G3 ; YES - CONTINUE BEEPING SPEAKER
JMP MFG_HALT ; STOP BLINKING LED
; SHORT BEEP:

0045
0045
0047
004A
004C
004E
0050
0052
0054
0055
0056
0057

G3: MOV BL,1 ; COUNTER FOR A SHORT BEEP
CALL BL,1 ; DO THE SOUND
CALL BL,1 ; DELAY BETWEEN BEEPS
DEC DL ; DONE WITH SHORTS
JNZ G3 ; DO SOME MORE
G5: LOOP G5 ; LONG DELAY BEFORE RETURN

0054
0055
0056
0057

G4: LOOP G4 ; RESTORE ORIG CONTENTS OF DS
POPFB ; RESTORE FLAGS TO ORIG SETTINGS
RET ; RETURN TO CALLER

ERR_BEEP ENDP
; ROUTINE TO SOUND BEEPER

0057
0057
0059
005B
005D
0060
0062
0064
0066
0069
006A
006C
006E
0070
0072
0074
0076
0078

BEEP PROC NEAR
MOV AL,10110110B ; SEL TIM 2,LSB,MSB,BINARY
OUT TIMER+3,AL ; WRITE THE TIMER MODE REG
JMP SHORT \$+2 ; IO DELAY
MOV AX,533H ; DIVISOR FOR 896 HZ
OUT TIMER+2,AX ; WRITE TIMER 2 CNT - LSB
JMP SHORT \$+2 ; IO DELAY

0064
0066
0069
006A
006C
006E
0070
0072
0074
0076
0078

MOV AL,AH ; WRITE TIMER 2 CNT - MSB
OUT TIMER+2,AL ; GET CURRENT SETTING OF PORT
IN AL,PORT_B ; SAVE THAT SETTING
JMP SHORT \$+2 ; IO DELAY
OR AL,03 ; TURN SPEAKER ON
OUT PORT_B,AL ; SET CNT TO WAIT 500 MS

0072
0074
0076
0078

G7: SUB CX,CX ; DELAY BEFORE TURNING OFF
LOOP G7 ; DELAY CNT EXPIRED?
DEC BL ; DELAY CNT EXPIRED?
JNZ G7 ; NO - CONTINUE BEEPING SPK

SECTION 5

```

007A 8A C4          MOV     AL,AH          ; RECOVER VALUE OF PORT
007C E6 61          OUT     PORT_B,AL
007E C3             RET     ; RETURN TO CALLER
007F             BEEP     ENDP

```

```

-----
THIS PROCEDURE WILL SEND A SOFTWARE RESET TO THE KEYBOARD.
SCAN CODE 'AA' SHOULD BE RETURNED TO THE CPU.
SCAN CODE '65' IS DEFINED FOR MANUFACTURING TEST
-----

```

```

007F             KBD_RESET PROC NEAR
007F 80 FF          MOV     AL,0FFH        ; SET KEYBOARD RESET COMMAND
0081 E8 0000 E      CALL    XMIT_8042     ; GO ISSUE THE COMMAND
0084 E3 23          JCXZ   G13           ; GO IF ERROR

0086 3C FA          CMP     AL,_KB_ACK    ;
0088 75 1F          JNZ    G13           ;

008A 80 FD          MOV     AL,0FDH       ; ENABLE KEYBOARD INTERRUPTS
008C E6 21          OUT     INTA01,AL     ; WRITE 8259 IHR
008E C6 06 006B R 00 MOV     MOV     INTR_FLAG,0 ; RESET INTERRUPT INDICATOR
0093 FB           STI     ; ENABLE INTERRUPTS

0094 83 0A          MOV     BL,10         ; TRY FOR 400 MSEC
0096 2B C9          SUB     CX,CX         ; SETUP INTERRUPT TIMEOUT CNT
0098 F6 06 006B R 02 G11:    TEST    INTR_FLAG,02H ; DID A KEYBOARD INTR OCCUR?
009D 75 06          JNZ    G12           ; YES - READ SCAN CODE RETURNED
009F E2 FF          LOOP   G11           ; NO - LOOP TILL TIMEOUT
00A1 FE CB          DEC     BL            ;
00A3 75 F3          JNZ    G11           ; TRY AGAIN

00A5 E4 60          G12:    IN     AL,_PORT_A   ; READ KEYBOARD SCAN CODE
00A7 8A D8          MOV     BL,AL         ; SAVE SCAN CODE JUST READ
00A9 C3             RET     ; RETURN TO CALLER
00AA             KBD_RESET ENDP

00AA             DDS     PROC NEAR
00AA 50             PUSH   AX             ;
00AB BB ----- R  MOV     AX,DATA       ;
00AE 8E D8          MOV     DS,AX         ;
00B0 58             POP    AX             ;
00B1 C3             RET     ;
00B2             DDS     ENDP

```

```

-----
; TEMPORARY INTERRUPT SERVICE ROUTINE
; 1. THIS ROUTINE IS ALSO LEFT IN PLACE AFTER THE
; POWER ON DIAGNOSTICS TO SERVICE UNUSED
; INTERRUPT VECTORS. LOCATION 'INTR_FLAG' WILL
; CONTAIN EITHER: 1. LEVEL OF HARDWARE INT. THAT
; CAUSED CODE TO BE EXEC.
; 2. 'FF' FOR NON-HARDWARE INTERRUPTS THAT WAS
; EXECUTED ACCIDENTLY.
-----

```

```

00B2             D11     PROC NEAR
00B2 1E             ASSUME DS:DATA
00B3 52             PUSH   DS             ;
00B4 50             PUSH   DX             ;
00B5 53             PUSH   BX             ;
00B6 E8 00AA R     CALL    DDS           ; SET DATA SEGMENT
00B9 80 0B          MOV     AL,0BH        ; READ IN-SERVICE REG
00BB E5 20          OUT     INTA00,AL     ; (FIND OUT WHAT LEVEL BEING
00BD E8 00         JMP     SHORT $+2     ; 10 DELAY
00BF 90             NOP                    ; SERVICED)
00C0 E4 20          IN     AL,INTA00     ; GET LEVEL
00C2 8A E0          MOV     AH,AL         ;
00C4 0A C4          OR     AL,AH          ; SAVE IT
00C6 75 04          JNZ    HW_INT        ; 00? (NO HARDWARE ISR ACTIVE)
00C8 B4 FF          MOV     AH,0FFH       ;
00CA EB 2A          JMP     SHORT SET_INTR_FLAG ; SET FLAG TO FF IF NON-HDWARE

00CC             HW_INT:
00CC 80 0B          MOV     AL,0BH        ;
00CE E6 A0          OUT     INTB00,AL     ; READ IN-SERVICE REG INT CHIP 2
00D0 E8 00         JMP     SHORT $+2     ; 10 DELAY
00D2 E4 A0          IN     AL,INTB00     ; CHECK THE SECOND INT CHIP
00D4 8A F8          MOV     BH,AL         ;
00D6 0A FF          OR     BH,BH         ; SAVE IT
00D8 74 0E          JZ     NOT_SEC       ; CONTINUE IF NOT
00DA E4 A1          IN     AL,INTB01     ; GET SECOND INT MASK
00DC 0A C7          OR     AL,BH         ; MASK OFF LVL BEING SERVICED
00DE E8 00         JMP     SHORT $+2     ; 10 DELAY
00E0 E6 A1          OUT     INTB01,AL     ;
00E2 80 20          MOV     AL,E01        ; SEND EO1 TO SECOND CHIP
00E4 EB 00          JMP     SHORT $+2     ; 10 DELAY
00E6 E6 A0          OUT     INTB00,AL     ;
00E8 E4 21          IN     AL,INTA01     ; GET MASK VALUE
00EA EB 00          JMP     SHORT $+2     ; 10 DELAY
00EC 0A C4          OR     AL,AH          ; MASK OFF LVL BEING SERVICED
00EE E6 21          OUT     INTA01,AL     ;
00F0 EB 00          JMP     SHORT $+2     ; 10 DELAY
00F2 80 20          MOV     AL,E01        ;
00F4 E6 20          OUT     INTA00,AL     ;

00F6             SET_INTR_FLAG:
00F6 88 26 006B R  MOV     INTR_FLAG,AH  ; SET FLAG
00FA 5B             POP    BX             ;
00FB 58             POP    AX             ; RESTORE REG AX CONTENTS
00FC 5A             POP    DX             ;
00FE 1F             POP    DS             ;
00FE CF             DUMMY_RETURN_1:     ; NEEDED IRET FOR VECTOR TABLE
00FF             D11     ENDP

```

```

-----
;--HARDWARE INT 13 (LEVEL 75H)-----
; SERVICE X287 INTERRUPTS
; THIS ROUTINE FIELDS X287 INTERRUPTS AND CONTROL
; IS PASSED TO THE NMI INTERRUPT HANDLER FOR
; COMPATABILITY.
-----

```

```

00FF             INT_287 PROC NEAR
00FF 50             PUSH   AX             ; SAVE AX
0100 32 C0          XOR    AL,AL         ;
0102 E6 F0          OUT    X287,AL       ; REMOVE THE INT REQUEST

0104 80 20          MOV    AL,E01        ; ENABLE THE INTERRUPT
0106 E6 A0          OUT    INTB00,AL     ; THE SLAVE
0108 E6 20          OUT    INTA00,AL     ; THE MASTER

010A 58             POP    AX             ; RESTORE AX
010B CD 02          INT    2             ; GIVE CONTROL TO NMI

```

```

0100 CF          IRET          ; RETURN
010E          INT_267 ENDP

;--HARDWARE INT 9 (LEVEL 71H) -----
; REDIRECT SLAVE INTERRUPT 9 TO INTERRUPT LEVEL 2
; THIS ROUTINE FIELDS LEVEL 9 INTERRUPTS AND
; CONTROL IS PASSED TO MASTER INTERRUPT LEVEL 2
;-----

010E          RE_DIRECT PROC NEAR
010E 50          PUSH AX          ; SAVE AX
010F 80 20      MOV AL,EOI          ; EOI TO SLAVE INT CONTROLLER
0111 E6 A0      OUT INTBOO,AL      ; RESTORE AX
0113 58          POP AX          ; GIVE CONTROL TO HARDWARE LEVEL 2
0114 CD 0A      INT OAH

0116 CF          IRET          ; RETURN
0117          RE_DIRECT ENDP

;-----
; PRINT A SEGMENT VALUE TO LOOK LIKE A 21 BIT ADDRESS
; DX MUST CONTAIN SEGMENT VALUE TO BE PRINTED
;-----

0117          PRT_SEG PROC NEAR
0117 8A C6      MOV AL,DH          ;GET MSB
0119 E8 0000 E CALL XPC_BYTE
011C 8A C2      MOV AL,DI          ; LSB
011E E8 0000 E CALL XPC_BYTE
0121 B0 30      MOV AL,'0'          ; PRINT A '0'
0123 E8 0000 E CALL PRT_HEX
0126 B0 20      MOV AL,' '          ; SPACE
0128 E8 0000 E CALL PRT_HEX
012B C3        RET
012C          PRT_SEG ENDP
CODE          ENDS
END

```



TITLE 12/16/83 TEST5 EXCEPTION INTERRUPT HANDLER

```

.LIST
PUBLIC POST5
PUBLIC EXC_00
PUBLIC EXC_01
PUBLIC EXC_02
PUBLIC EXC_03
PUBLIC EXC_04
PUBLIC EXC_05
PUBLIC EXC_06
PUBLIC EXC_07
PUBLIC EXC_08
PUBLIC EXC_09
PUBLIC EXC_10
PUBLIC EXC_11
PUBLIC EXC_12
PUBLIC EXC_13
PUBLIC EXC_14
PUBLIC EXC_15
PUBLIC EXC_16
PUBLIC EXC_17
PUBLIC EXC_18
PUBLIC EXC_19
PUBLIC EXC_20
PUBLIC EXC_21
PUBLIC EXC_22
PUBLIC EXC_23
PUBLIC EXC_24
PUBLIC EXC_25
PUBLIC EXC_26
PUBLIC EXC_27
PUBLIC EXC_28
PUBLIC EXC_29
PUBLIC EXC_30
PUBLIC EXC_31

PUBLIC SYS_32
PUBLIC SYS_33
PUBLIC SYS_34
PUBLIC SYS_35
PUBLIC SYS_36
PUBLIC SYS_37
PUBLIC SYS_38

C INCLUDE SEGMENT.SRC
C CODE SEGMENT BYTE PUBLIC
C

;----- EXCEPTION INTERRUPT ROUTINE -----
ASSUME CS:CODE, DS:ABS0

0000 POST5:
0000 EXC_00: MOV AL,90H ;<<<<SET CHECKPOINT<<<<<<
0000 B0 90 JMP TEST_EXC ; GO TEST IF EXCEPTION WAS EXPECTED
0002 E9 00D7 R
0005 EXC_01: MOV AL,91H ;<<<<SET CHECKPOINT<<<<<<
0005 0095 JMP TEST_EXC ; GO TEST IF EXCEPTION WAS EXPECTED
0007 B0 91
000A EXC_02: MOV AL,92H ;<<<<SET CHECKPOINT<<<<<<
000A 80 92 JMP TEST_EXC ; GO TEST IF EXCEPTION WAS EXPECTED
000C E9 00D7 R
000F EXC_03: MOV AL,93H ;<<<<SET CHECKPOINT<<<<<<
0011 0093 JMP TEST_EXC ; GO TEST IF EXCEPTION WAS EXPECTED
0014 B0 93
0014 EXC_04: MOV AL,94H ;<<<<SET CHECKPOINT<<<<<<
0016 0094 JMP TEST_EXC ; GO TEST IF EXCEPTION WAS EXPECTED
0019 B0 94
0019 EXC_05:
0019 06 PUSH ES
001A B8 0048 MOV AX,ES_TEMP ; LOAD ES REGISTER
001D 8E C0 MOV ES,AX

;----- FIX BOUND PARAMETERS
001F 2B FF SUB D1,D1 ; POINT BEGINING OF THE BLOCK
0021 26: C7 05 0000 MOV WORD PTR ES:[D1],0 ; SET FIRST WORD TO ZERO
0026 26: C7 45 02 7FFF MOV WORD PTR ES:[D1+2],07FFF ; SET SECOND TO 07FFF
002C 07 POP ES

002D B0 95 MOV AL,95H ;<<<<SET CHECKPOINT<<<<<<
002F E9 00D7 R ; GO TEST IF EXCEPTION WAS EXPECTED
0032 EXC_06: JMP TEST_EXC
0032 B0 96 MOV AL,96H ;<<<<SET CHECKPOINT<<<<<<
0034 E9 00D7 R ; GO TEST IF EXCEPTION WAS EXPECTED
0037 EXC_07: JMP TEST_EXC
0037 B0 97 MOV AL,97H ;<<<<SET CHECKPOINT<<<<<<
0039 E9 00D7 R ; GO TEST IF EXCEPTION WAS EXPECTED
003C EXC_08: MOV AL,98H ;<<<<SET CHECKPOINT<<<<<<
003C 80 98 JMP TEST_EXC ; GO TEST IF EXCEPTION WAS EXPECTED
0041 B0 98
0041 EXC_09: MOV AL,99H ;<<<<SET CHECKPOINT<<<<<<
0043 E9 00D7 R ; GO TEST IF EXCEPTION WAS EXPECTED
0046 B0 99
0046 EXC_10: MOV AL,9AH ;<<<<SET CHECKPOINT<<<<<<
0048 E9 00D7 R ; GO TEST IF EXCEPTION WAS EXPECTED
004B B0 9A
004B EXC_11: MOV AL,9BH ;<<<<SET CHECKPOINT<<<<<<
004D E9 00D7 R ; GO TEST IF EXCEPTION WAS EXPECTED
0050 B0 9B
0050 EXC_12: MOV AL,9CH ;<<<<SET CHECKPOINT<<<<<<
0052 E9 00D7 R ; GO TEST IF EXCEPTION WAS EXPECTED
0055 B0 9C
0055 EXC_13: MOV AL,9DH ;<<<<SET CHECKPOINT<<<<<<
0057 EB 7E 90 JMP TEST_EXC ; GO TEST IF EXCEPTION WAS EXPECTED
005A B0 9D
005A EXC_14: MOV AL,9EH ;<<<<SET CHECKPOINT<<<<<<
005A 80 9E JMP TEST_EXC ; GO TEST IF EXCEPTION WAS EXPECTED
005C EB 79 90
005F B0 9F
005F EXC_15: MOV AL,9FH ;<<<<SET CHECKPOINT<<<<<<
0061 EB 74 90 JMP TEST_EXC ; GO TEST IF EXCEPTION WAS EXPECTED
0064 B0 9F
0064 EXC_16: MOV AL,0A0H ;<<<<SET CHECKPOINT<<<<<<
0066 EB 6F 90 JMP TEST_EXC ; GO TEST IF EXCEPTION WAS EXPECTED
0069 B0 A0
0069 EXC_17: MOV AL,0A1H ;<<<<SET CHECKPOINT<<<<<<
006B EB 6A 90 JMP TEST_EXC ; GO TEST IF EXCEPTION WAS EXPECTED
006E B0 A1
006E EXC_18: MOV AL,0A2H ;<<<<SET CHECKPOINT<<<<<<
006E B0 A2

```

SECTION 5

```

0070 EB 65 90
0073
0073 BO A2
0075 EB 60 90
0078
0078 BO A3
007A EB 58 90
007D
007D BO A4
007F EB 56 90
0082
0082 BO A5
0084 EB 51 90
0087
0087 BO A6
0089 EB 4C 90
008C
008C BO A7
008E EB 47 90
0091
0091 BO A8
0093 EB 42 90
0096
0096 BO A9
0098 EB 3D 90
009B
009B BO AA
009D EB 38 90
00A0
00A0 BO AB
00A2 EB 33 90
00A5
00A5 BO AC
00A7 EB 2E 90
00AA
00AA BO AD
00AC EB 29 90
00AF
00AF BO AE
00B1 EB 24 90

00B4
00B4 BO AF
00B6 EB 1F 90
00B9
00B9 BO B0
00BB EB 1A 90
00BE
00BE BO B1
00C0 EB 15 90
00C3
00C3 BO B2
00C5 EB 10 90
00C8
00C8 BO B3
00CA EB 0B 90
00CD
00CD BO B4
00CF EB 06 90
00D2
00D2 BO B5
00D4 EB 01 90
00D7
00D7 E6 80
00D9 3C AE
00DB 77 22

00DD 1E
00DE 50
00DF B8 0008
00E2 8E D8
00E4 C7 06 0048 FFFF
00EA C6 06 004D 93
00EF B8 0048
00F2 8E C0
00F4 58
00F5 1F
00F6 5A
00F7 59
00F8 51
00F9 83 F9 40
00FC 75 01
00FE 52

00FF
00FF 86 E0
0101 E4 8B
0103 3A C4
0105 74 0E
0107
0107 E4 80
0109 3C 3B
010B 72 01
010D CF
010E
010E 86 E0
0110 E6 80

0112 F4
0113 EB F9
0115 2A C0
0117 E6 8B
0119 B8 0100
011C CF
011D

EXC_19: JMP TEST_EXC ; GO TEST IF EXCEPTION WAS EXPECTED
MOV AL,0A2H ; <<<<SET CHECKPOINT<<<<
JMP TEST_EXC ; GO TEST IF EXCEPTION WAS EXPECTED
EXC_20: MOV AL,0A3H ; <<<<SET CHECKPOINT<<<<
JMP TEST_EXC ; GO TEST IF EXCEPTION WAS EXPECTED
EXC_21: MOV AL,0A4H ; <<<<SET CHECKPOINT<<<<
JMP TEST_EXC ; GO TEST IF EXCEPTION WAS EXPECTED
EXC_22: MOV AL,0A5H ; <<<<SET CHECKPOINT<<<<
JMP TEST_EXC ; GO TEST IF EXCEPTION WAS EXPECTED
EXC_23: MOV AL,0A6H ; <<<<SET CHECKPOINT<<<<
JMP TEST_EXC ; GO TEST IF EXCEPTION WAS EXPECTED
EXC_24: MOV AL,0A7H ; <<<<SET CHECKPOINT<<<<
JMP TEST_EXC ; GO TEST IF EXCEPTION WAS EXPECTED
EXC_25: MOV AL,0A8H ; <<<<SET CHECKPOINT<<<<
JMP TEST_EXC ; GO TEST IF EXCEPTION WAS EXPECTED
EXC_26: MOV AL,0A9H ; <<<<SET CHECKPOINT<<<<
JMP TEST_EXC ; GO TEST IF EXCEPTION WAS EXPECTED
EXC_27: MOV AL,0AAH ; <<<<SET CHECKPOINT<<<<
JMP TEST_EXC ; GO TEST IF EXCEPTION WAS EXPECTED
EXC_28: MOV AL,0ABH ; <<<<SET CHECKPOINT<<<<
JMP TEST_EXC ; GO TEST IF EXCEPTION WAS EXPECTED
EXC_29: MOV AL,0ACH ; <<<<SET CHECKPOINT<<<<
JMP TEST_EXC ; GO TEST IF EXCEPTION WAS EXPECTED
EXC_30: MOV AL,0ADH ; <<<<SET CHECKPOINT<<<<
JMP TEST_EXC ; GO TEST IF EXCEPTION WAS EXPECTED
EXC_31: MOV AL,0AEH ; <<<<SET CHECKPOINT<<<<
JMP TEST_EXC ; GO TEST IF EXCEPTION WAS EXPECTED

SYS_32: MOV AL,0AFH ; <<<<SET CHECKPOINT<<<<
JMP TEST_EXC ; GO TEST IF INTERRUPT WAS EXPECTED
SYS_33: MOV AL,0B0H ; <<<<SET CHECKPOINT<<<<
JMP TEST_EXC ; GO TEST IF INTERRUPT WAS EXPECTED
SYS_34: MOV AL,0B1H ; <<<<SET CHECKPOINT<<<<
JMP TEST_EXC ; GO TEST IF INTERRUPT WAS EXPECTED
SYS_35: MOV AL,0B2H ; <<<<SET CHECKPOINT<<<<
JMP TEST_EXC ; GO TEST IF INTERRUPT WAS EXPECTED
SYS_36: MOV AL,0B3H ; <<<<SET CHECKPOINT<<<<
JMP TEST_EXC ; GO TEST IF INTERRUPT WAS EXPECTED
SYS_37: MOV AL,0B4H ; <<<<SET CHECKPOINT<<<<
JMP TEST_EXC ; GO TEST IF INTERRUPT WAS EXPECTED
SYS_38: MOV AL,0B5H ; <<<<SET CHECKPOINT<<<<
JMP TEST_EXC ; GO TEST IF INTERRUPT WAS EXPECTED

TEST_EXC: OUT MFC_PORT,AL ; OUTPUT THE CHECKPOINT
CMP AL,0AEH ; CHECK FOR EXCEPTION
JNC TEST_EXC0 ; GO IF A SYSTEM INT

PUSH DS ; SAVE THE CURRENT DATA SEGMENT
PUSH AX ;
MOV AX,GDT_PTR ;
MOV DS,AX ;
BYTE PTR DS: (ES_TEMP,SEG_LIMIT,MAX_SEG_LEN ;
; ES_TEMP,DATA_ACC_RIGHTS),CPLO_DATA_ACCESS
POP AX ; RESTORE REGS
POP DS ;
POP DX ; CHECK IF CODE SEG SECOND ON STACK
POP CX ;
PUSH CX ;
CMP CX,SYS_ROM_CS ;
JNZ TEST_EXC0 ; CONTINUE IF ERROR CODE
PUSH DX ; PUT SEGMENT BACK ON STACK

TEST_EXC0: XCHG AH,AL ; SAVE THE CHECKPOINT
IN AL,DMA_PAGE+0AH ;
CMP AL,AH ; WAS THE EXCEPTION EXPECTED?
JZ TEST_EXC3 ; GO IF YES
TEST_EXC1: IN AL,MFC_PORT ; CHECK THE CURRENT CHKPT
CMP AL,03BH ; HALT IF CHKPT BELOW 3BH
JB TEST_EXC2 ;
IRET ;
TEST_EXC2: XCHG AH,AL ; OUTPUT THE CURRENT CHECKPOINT
OUT MFC_PORT,AL ; <<<<CRPT 90 THRU B5<<<<

HLT ;
JMP TEST_EXC2 ; INSURE SYSTEM HALT
TEST_EXC3: SUB AL,AL ; CLEAR DMA PAGE
OUT DMA_PAGE+0AH,AL ;
MOV AX,0100H ; USED FOR BOUND INSTR EXPECTED INTS
IRET ; RETURN
CODE ENDS
END

```

TITLE 01/03/84 TEST6 POWER ON SELF TEST

```

.LIST
PUBLIC STGTST_CNT
PUBLIC ROM_ERR
PUBLIC BOOT_STRAP_1
PUBLIC XM1T_8042
PUBLIC POST6
PUBLIC H5

C INCLUDE SEGMENT.SRC
C CODE SEGMENT BYTE PUBLIC

;
EXTRN E0:NEAR
EXTRN E MSG:NEAR
EXTRN KBD_RESET:NEAR
EXTRN XPC_BYTE:NEAR
EXTRN F1:NEAR
EXTRN VECTOR_TABLE:NEAR
EXTRN NM1_INT:NEAR
EXTRN PRINT_SCREEN_1:NEAR
EXTRN BLINK_INT:NEAR
EXTRN PRT_HEX:NEAR
EXTRN F3B:NEAR
EXTRN PRT_SEG:NEAR
EXTRN XPC_BYTE:NEAR
EXTRN E1:NEAR
EXTRN ROM_CHECK:NEAR
EXTRN ROS_CHECKSUM:NEAR
EXTRN SEEK:NEAR
EXTRN F3:NEAR
EXTRN ERR_BEEP:NEAR
EXTRN P_MSG:NEAR
EXTRN START_1:NEAR
EXTRN F4:NEAR
EXTRN FAE:NEAR
EXTRN DDS:NEAR
EXTRN F3A:NEAR
EXTRN DISK_BASE:NEAR
EXTRN F3D:NEAR
EXTRN PROC_SHUTDOWN:NEAR
EXTRN SYSINIT1:NEAR
EXTRN PROT_PRT_HEX:NEAR
EXTRN DISK_IO:NEAR
EXTRN HD_INT:NEAR
EXTRN C8042:NEAR
EXTRN BOOT_INVA:NEAR
PAGE
        ASSUME CS:CODE
        ASSUME DS:DATA

0000          POST6  PROC  NEAR

;-----
; THIS SUBROUTINE PERFORMS A READ/WRITE STORAGE TEST ON A BLOCK ;
; OF STORAGE. ;
; ENTRY REQUIREMENTS: ;
; ES = ADDRESS OF STORAGE SEGMENT BEING TESTED ;
; DS = ADDRESS OF STORAGE SEGMENT BEING TESTED ;
; CX = WORD COUNT OF STORAGE BLOCK TO BE TESTED ;
; EXIT PARAMETERS: ;
; ZERO FLAG = 0 IF STORAGE ERROR (DATA COMPARE OR PARITY ;
; CHECK). AL=0 DENOTES A PARITY CHECK. ELSE AL=XOR'ED ;
; BIT PATTERN OF THE EXPECTED DATA PATTERN VS THE ACTUAL ;
; DATA READ. ;
; AX,BX,CX,DX,DI, AND SI ARE ALL DESTROYED. ;
;-----

STGTST_CNT  PROC  NEAR
0000      MOV     BX,CX          ; SAVE WORD COUNT OF BLOCK TO TEST
0002      IN     AL,PORT_B
0004      JMP     SHORT $+2      ; IO DELAY
0006      OR     AL,RAM_PAR_OFF  ; TOGGLE PARITY CHECK LATCHES
0008      OUT    PORT_B,AL
000A      JMP     SHORT $+2      ; IO DELAY
000C      AND     AL,RAM_PAR_ON
000E      OUT    PORT_B,AL

;----- ROLL A BIT THROUGH THE FIRST WORD
0010      MOV     DX,0001H      ; WRITE THE INIT DATA PATTERN
0013      MOV     CX,16         ; ROLL 16 BIT POSITIONS
0016      SUB     DI,D1         ; START AT BEGINING OF BLOCK
0018      SUB     SI,SI         ; INITIALIZE DESTINATION POINTER
001A      MOV     AX,DX         ; GET THE PATTERN
001C      STOSW                ; STORE DATA PATTERN
001D      SUB     SI,SI         ; START AT BEGINING
001F      LODSW                ; GET THE FIRST WRITTEN
0020      XOR     AX,DX         ; INSURE DATA AS EXPECTED
0022      JZ     C1_A          ; EXIT IF NOT
0024      JMP     C13          ; SHIFT BIT TO NEXT BIT POSITION
0027      SHL     DX,1         ; LOOP TILL DONE
0029      LOOP   C1

;----- CHECK CAS LINES FOR HIGH BYTE LOW BYTE
002B      SUB     DI,D1         ; START AT BEGINING OF BLOCK
002D      SUB     SI,SI         ; INITIALIZE DESTINATION POINTER
002F      SUB     AX,AX         ; WRITE 0
0031      MOV     DX,00FF0H    ; STORE DATA PATTERN
0034      AB                     ; AT THE FIRST ODD LOCATION
0035      BF 0001              ; WRITE A BYTE OF FF
0038      MOV     BYTE PTR [DI],OFFH
003B      SUB     DI,D1         ; GET THE DATA
003D      MOV     AX,WORD PTR [DI] ; CHECK THE FIRST WRITTEN
003F      XOR     AX,DX
0041      JZ     C1_B          ; EXIT IF NOT
0043      JMP     C13

C1_B:     SUB     DI,D1         ; START AT BEGINING OF BLOCK
0048      SUB     AX,AX         ; WRITE 0
004A      MOV     DX,000FFH    ; STORE DATA PATTERN
004D      AB                     ; AT THE FIRST EVEN LOCATION
004E      BF 0001              ; WRITE A BYTE OF FF
0050      MOV     BYTE PTR [DI],OFFH
0053      SUB     DI,D1         ; GET THE DATA
0055      MOV     AX,WORD PTR [DI] ; CHECK THE FIRST WRITTEN
0057      XOR     AX,DX
0059      JNZ    C13          ; EXIT IF NOT

;----- TEMP SAVE FOR AX (PUSH NOT ALLOWED)
005B      OUT     DMA_PAGE+8,AL ; SAVE AX
005D      XCHG   AL,AH
005F      JMP     SHORT $+2
0061      OUT     DMA_PAGE+9,AL ;

```

SECTION 5

```

;----- CHECK IO OR BASE RAM
0063 E4 61          IN      AL,PORT_B          ; CHECK FOR IO/PAR CHECK
0065 24 C0          AND     AL,PARITY_ERR        ; STRIP UNWANTED BITS
0067 86 C4          XCHG   AL,AH              ; SAVE ERROR
0069 E4 87          IN      AL,DMA_PAGE+6      ; CHECK FOR R/W OR IO ERR
006B 22 E0          AND     AH,AL              ;

;----- RESTORE AX
006D E4 8A          IN      AL,DMA_PAGE+9      ; GET AH
006F 86 C4          XCHG   AL,AH              ;
0071 E4 89          IN      AL,DMA_PAGE+8      ; GET AL

;----- PARITY ERROR EXIT
0073 75 50          JNZ    C13                ; GO IF YES
0075 BA AA55       MOV    DX,0AA55H          ; WRITE THE INIT DATA PATTERN
0078 2B FF         C3:   SUB    D1,D1          ; START AT BEGINING OF BLOCK
007A 2B FF         C4:   SUB    S1,S1          ; INITIALIZE DESTINATION POINTER
007C 8B CB         MOV    CX,BX              ; SETUP BYTE COUNT FOR LOOP
007E 8B C2         MOV    AX,DX              ; GET THE PATTERN
0080 F3 AB         C5:   REP    STOSW          ; STORE 64K BYTES (32K WORDS)
0082 8B CB         MOV    CX,BX              ; SET COUNT
0084 2B FF         SUB    SI,S1              ; START AT BEGINING
0086 AD           LODSW          ; GET THE FIRST WRITTEN
0087 33 C2         XOR    AX,DX              ; INSURE DATA AS EXPECTED
0089 75 3A         JNZ    C13                ; EXIT IF NOT
008B E2 F9         LOOP   C6                 ; LOOP TILL DONE

;----- TEMP SAVE FOR AX (PUSH NOT ALLOWED)
008D E6 89          OUT    DMA_PAGE+8,AL      ; SAVE AX
008F 86 C4          XCHG   AL,AH              ;
0091 EB 00          JMP    SHORT $+2          ;
0093 E6 8A          OUT    DMA_PAGE+9,AL      ;

;----- CHECK IO OR BASE RAM
0095 E4 61          IN      AL,PORT_B          ; CHECK FOR IO/PAR CHECK
0097 24 C0          AND     AL,PARITY_ERR        ; STRIP UNWANTED BITS
0099 86 C4          XCHG   AL,AH              ; SAVE ERROR
009B E4 87          IN      AL,DMA_PAGE+6      ; CHECK FOR R/W OR IO ERR
009D 22 E0          AND     AH,AL              ;

;----- RESTORE AX
009F E4 8A          IN      AL,DMA_PAGE+9      ; GET AH
00A1 86 C4          XCHG   AL,AH              ;
00A3 E4 89          IN      AL,DMA_PAGE+8      ; GET AL

;----- PARITY ERROR EXIT
00A5 75 1E          JNZ    C13                ; GO IF YES

;----- CHECK FOR END OF 64K BLOCK
00A7 23 D2          AND     DX,DX              ; ENDING ZERO PATTERN WRITTEN TO STG ?
00A9 74 1A          JZ     C14                ; YES - RETURN TO CALLER WITH AL=0

;----- SETUP NEXT PATTERN
00AB 81 FA 55AA     CMP    DX,055AAH          ; CHECK IF LAST PATTERN =55AA
00AD 74 0F         C9:   JZ     C9              ; GO IF NOT
00B1 81 FA 0101     CMP    DX,0101H          ; LAST PATTERN 0101?
00B5 74 0F         C10:  JZ     C10                ; GO IF YES
00B7 BA 55AA     MOV    DX,055AAH          ; WRITE 55AA TO STORAGE
00BA EB BC         JMP    C3                  ;

;----- LAST PATTERN = 0000
00BC 2B D2         C8:   SUB    DX,DX              ; WRITE 0000 TO STORAGE
00BE EB B8         JMP    C3                  ;

;----- INSURE PARITY BITS ARE NOT STUCK ON
00C0 BA 0101       C9:   MOV    DX,0101H          ; WRITE 0101 TO STORAGE
00C3 EB B3         JMP    C3                  ;

;----- EXIT
00C5 C13:           C13:  RET
00C5 C14:           C14:  RET

;----- CHECKER BOARD TEST
00C6 2B FF         C10:  SUB    D1,D1              ; POINT TO START OF BLOCK
00C8 8B CB         MOV    CX,BX              ; GET THE BLOCK COUNT
00CA D1 E9         SHR    CX,1                ; DIVIDE BY 2
00CC B8 5555     C11:  MOV    AX,010101010101010B ; FIRST CHECKER PATTERN
00CF AB          STOSW          ; WRITE IT
00D0 B8 AAAA     MOV    AX,1010101010101010B ; SECOND CHECKER PATTERN
00D3 AB          STOSW          ; WRITE IT
00D4 E2 F6         LOOP   C11                ; DO IT FOR CX COUNT
00D6 2B F6         SUB    SI,S1              ; POINT TO START OF BLOCK
00D8 8B CB         MOV    CX,BX              ; GET THE BLOCK COUNT
00DA D1 E9         SHR    CX,1                ; DIVIDE BY 2
00DC AD           LODSW          ; GET THE DATA
00DD 35 5555     XOR    AX,010101010101010B ; CHECK CORRECT
00E0 75 E3         JNZ    C13                ; EXIT IF NOT
00E2 AD           LODSW          ; GET NEXT DATA
00E3 35 AAAA     XOR    AX,1010101010101010B ; GO IF NOT CORRECT
00E6 75 DD         JNZ    C13                ; EXIT IF NOT
00E8 E2 F2         LOOP   C12                ; CONTINUE TILL DONE

;----- TEMP SAVE FOR AX (PUSH NOT ALLOWED)
00EA E6 89          OUT    DMA_PAGE+8,AL      ; SAVE AX
00EC 86 C4          XCHG   AL,AH              ;

```



```

00AC 2B C0                               SUB AX,AX ;
00AE 0F                                   + STR AX ; GET THE TR REG
00AF + ??0008 DB 0F ;
00AF 8B C8 + LABEL BYTE ;
00B1 + MOV CX,AX ;
00AF + ??0009 LABEL BYTE ;
00AF 00 + ORG OFFSET CS:??0008 ;
00B1 + DB 000H ;
00B1 25 00F8 + ORG OFFSET CS:??0009 ;
00B4 3D 0068 AND AX,0F8H ;
00B7 75 08 CMP AX,POST_TR ; CORRECT SELECTOR?
                                JNZ ERROR

;----- TEST 286 CONTROL FLAGS

00B9 FD STD ; SET DIRECTION FLAG FOR DECREMENT
00BA 9C PUSHF ; GET THE FLAGS
00BB 58 POP AX ;
00BC A9 0200 TEST AX,0200H ; INTERRUPT FLAG SHOULD BE OFF
00BF 74 03 JZ T7_4 ; CONTINUE IF OFF
00C1 E9 02EA R ERROR: JMP ERROR_EXIT ; GO IF NOT
00C4 00C4 A9 0400 T7_4: TEST AX,0400H ; CHECK DIRECTION FLAG
00C7 75 03 JNZ T7_5 ; GO IF NOT SET
00C9 E9 02EA R T7_5: CLD ; CLEAR DIRECTION FLAG
00CC FC

00CD 9C PUSHF ; INSURE DIRECTION FLAG IS RESET
00CE 58 POP AX ;
00CF A9 0400 TEST AX,0400H ;
00D2 74 03 JZ T7_6 ;
00D4 E9 02EA R T7_6: JMP ERROR_EXIT ; GO IF NOT
00D7

-----
: VERIFY 286 BOUND INSTRUCTION :
: DESCRIPTION :
: CREATE A SIGNED ARRAY INDEX WITHIN AND :
: OUTSIDE THE LIMITS (EXPECT INT 5) :
-----

00D7 B0 F4 MOV AL,0F4H ;
00D9 E6 B0 OUT MFG_PORT,AL ; <<<<<<CHECKPOINT F4 >>>>>>
00DB BB 0008 MOV AX,ES_TEMP ; LOAD ES REGISTER
00DE 8E C0 MOV ES,AX ;

;----- CHECK BOUND FUNCTIONS CORRECTLY

00E0 2B FF SUB DI,D1 ; POINT BEGINING OF THE BLOCK
00E2 26: C7 05 0000 MOV WORD PTR ES:[DI],0 ; SET FIRST WORD TO ZERO
00E7 26: C7 45 02 7FFF MOV WORD PTR ES:[DI+2],07FFFH ; SET SECOND TO 07FFFH
00ED B0 95 MOV AL,095H ; SET INTERRUPT 5 FLAG
00EF E6 8B OUT DMA_PAGE+0AH,AL ;

00F1 B8 1000 MOV AX,1000H ; SET AX WITHIN BOUNDS
00F4 26 + SEGOV ES ; USE THE ES REG
DB 026H ;
+ BOUND AX,[DI] ;
+ ??000B LABEL BYTE ;
00F5 8B 05 + MOV AX,[DI] ;
00F7 + LABEL BYTE ;
00F5 + ORG OFFSET CS:??000B ;
00F5 + DB 062H ;
00F7 + ORG OFFSET CS:??000C ;
+ SUB CX,CX ; WAIT FOR POSSIBLE INTERRUPT
LOOPA: LOOP LOOPA ;
00F9 E2 FE LOOPA: IN AL,DMA_PAGE+0AH ; GET THE RESULTS
00FB E4 8B IN AL,OH ; DID AN INTERRUPT OCCUR?
00FD 3C 00 CMP AL,0 ; DID AN INTERRUPT OCCUR?
00FF 75 03 JNZ T7_7 ; CONTINUE IF NOT
0101 E9 02EA R JMP ERROR_EXIT ; GO IF YES
0104

T7_7: ;----- CHECK LOW BOUND WORD CAUSES INT 5

0104 2B FF SUB DI,D1 ; POINT BEGINING OF THE BLOCK
0106 26: C7 05 3FF0 MOV WORD PTR ES:[DI],03FF0H ; SET FIRST WORD TO 03FF0H

010B B8 1000 MOV AX,1000H ; SET AX OUT OF BOUNDS
010E 26 + SEGOV ES ; USE THE ES REG
DB 026H ;
+ BOUND AX,[DI] ;
+ ??000E LABEL BYTE ;
010F 8B 05 + MOV AX,[DI] ;
0111 + LABEL BYTE ;
010F + ORG OFFSET CS:??000E ;
010F + DB 062H ;
0111 + ORG OFFSET CS:??000F ;
+ SUB CX,CX ; WAIT FOR POSSIBLE INTERRUPT
LOOPB: IN AL,DMA_PAGE+0AH ; GET THE RESULTS
CMP AL,OH ; DID AN INTERRUPT OCCUR?
LOOPNZ LOOPB ; TRY AGAIN
JZ T7_8 ; CONTINUE IF INTERRUPT
JMP ERROR_EXIT ; GO IF NO INTERRUPT

;----- CHECK HIGH BOUND WORD CAUSES INT 5

011E B0 95 T7_8: MOV AL,95H ; SET FLAG FOR INTERRUPT
0120 E6 8B OUT DMA_PAGE+0AH,AL ;

0122 2B FF SUB DI,D1 ; POINT BEGINING OF THE BLOCK
0124 26: C7 05 0000 MOV WORD PTR ES:[DI],0 ; SET FIRST WORD TO 0
0129 26: C7 45 02 OFFF MOV WORD PTR ES:[DI+2],OFFFH ; SET SECOND TO OFFFH
012F B8 1000 MOV AX,1000H ; SET AX OUT OF BOUNDS
0132 26 + SEGOV ES ; USE THE ES REG
+ DB 026H ;
+ BOUND AX,[DI] ;
+ ??0011 LABEL BYTE ;
0133 8B 05 + MOV AX,[DI] ;
+ ??0012 LABEL BYTE ;
0135 + ORG OFFSET CS:??0011 ;
0133 + DB 062H ;
0135 + ORG OFFSET CS:??0012 ;
+ SUB CX,CX ; WAIT FOR POSSIBLE INTERRUPT
LOOPC: IN AL,DMA_PAGE+0AH ; GET THE RESULTS
CMP AL,OH ; DID AN INTERRUPT OCCUR?
LOOPNZ LOOPC ; TRY AGAIN
JZ T7_9 ; CONTINUE IF INTERRUPT
JMP ERROR_EXIT ; GO IF NO INTERRUPT

-----
: VERIFY PUSH ALL AND POP ALL INSTRUCTIONS:
: DESCRIPTION :

```

SECTION 5

```

DESCR_DEF      SEG, MAX_SEG_LEN, NSEG@_LO, NSEG@_HI, CPLD_DATA_ACCESS
0058 FFFF      + DW MAX_SEG_LEN      ; Segment limit
005A 0000      + DW NSEG@_LO      ; Segment base address - low word
005C 00        + DB NSEG@_HI      ; Segment base address - high byte
005D 93        + DB CPLD_DATA_ACCESS ; Access rights byte
005E 0000      + DW 0              ; Reserved
;
DESCR_DEF      SEG, MAX_SEG_LEN, NSEG@_LO, NSEG@_HI, CPLD_DATA_ACCESS
0060 FFFF      + DW MAX_SEG_LEN      ; Segment limit
0062 0000      + DW NSEG@_LO      ; Segment base address - low word
0064 00        + DB NSEG@_HI      ; Segment base address - high byte
0065 93        + DB CPLD_DATA_ACCESS ; Access rights byte
0066 0000      + DW 0              ; Reserved
;
; POST_TR
TR_LOC:
DESCR_DEF      SEG, 800H, 0C000H, 0, FREE_TSS
0068 0800      + DW 800H          ; Segment limit
006A C000      + DW 0C000H       ; Segment base address - low word
006C 00        + DB 0              ; Segment base address - high byte
006D 81        + DB FREE_TSS     ; Access rights byte
006E 0000      + DW 0              ; Reserved
;
; POST_TSS_PTR
DESCR_DEF      SEG, 800H, TR_LOC, 0, CPLD_DATA_ACCESS
0070 0800      + DW 800H          ; Segment limit
0072 0068 R    + DW TR_LOC       ; Segment base address - low word
0074 00        + DB 0              ; Segment base address - high byte
0075 93        + DB CPLD_DATA_ACCESS ; Access rights byte
0076 0000      + DW 0              ; Reserved
;
LDT_LOC:
; POST_LDT
DESCR_DEF      SEG, GDT_LEN, 0D000H, 0, LDT_DESC
0078 0088      + DW GDT_LEN      ; Segment limit
007A 0000      + DW 0D000H       ; Segment base address - low word
007C 00        + DB 0              ; Segment base address - high byte
007D E2        + DB LDT_DESC     ; Access rights byte
007E 0000      + DW 0              ; Reserved
;
; POST_LDT_PTR
DESCR_DEF      SEG, GDT_LEN, LDT_LOC, 0, CPLD_DATA_ACCESS
0080 0088      + DW GDT_LEN      ; Segment limit
0082 0078 R    + DW LDT_LOC       ; Segment base address - low word
0084 00        + DB 0              ; Segment base address - high byte
0085 93        + DB CPLD_DATA_ACCESS ; Access rights byte
0086 0000      + DW 0              ; Reserved
;
PAGE
;
GDT_DATA_END LABEL WORD
;
;
; END OF PRE-ALLOCATED GDT
;
GDT_BLD PROC NEAR
0088 8E 0000 R  MOV SI, OFFSET GDT_DATA_START ; DS:SI --> GDT
008B B9 0044    MOV CX, (GDT_DATA_END-GDT_DATA_START)/2 ; NUMBER OF WORDS TO COPY
008E F3/ A5     REP MOVSW ; COPY GDT INTO RAM
0090 C3        RET 0
;
0091 GDT_BLD ENDP
0091 CODE ENDS ; MPC ENDS

```

```

;
; TITLE SIDT_BLD 6/10/83 PROTECTED MODE INTERRUPT TABLE
;
; SIDT_BLD include files
;
; INCLUDE SYSDATA.INC
; INCLUDE ACCESS.INC
;
; INCLUDE SYSDATA.MAC
; INCLUDE IAPX286.MAC
;
; .LIST
C INCLUDE SEGMENT.SRC
C CODE SEGMENT BYTE PUBLIC
C
; ASSUME CS:CODE
; ASSUME SS:NOTHING
; ASSUME DS:NOTHING
; ASSUME ES:NOTHING
;
0000 PUBLIC SIDT_BLD
PROC NEAR
;
; BUILD THE IDT. THE IDT WILL CONTAIN VECTORS FOR
; EXCEPTION HANDLERS
;
0000 BE 0066 R MOV SI,OFFSET SYS_IDT_OFFSETS ; MAKE DS:SI POINT TO
0003 8C C8 MOV AX,CS ; INTERRUPT ENTRY POINTS
0005 8E D8 MOV DS,AX ;
0007 BF D0A0 MOV DI,SYS_IDT_LOC ; POINT TO SYS_IDT_LOC
000A 2B C0 SUB AX,AX ;
000C 8E C0 MOV ES,AX ; WHERE THE IDT WILL BE.
;
000E BB 0040 MOV BX,SYS_RQM_CS ; CS IS THE SAME FOR ALL INTERRUPTS
0011 B6 87 MOV DH,TRAP_GATE ; ACCESS RIGHTS BYTE FOR THE GATE
0013 B2 00 MOV DL,0 ; THE WORD COUNT FIELD IS UNUSED
;
0015 B9 0020 MOV CX,32 ; THERE ARE 32 RESERVED INTERRUPTS
;
0018 LOW_IDT: ; THIS LOOP BUILDS 32 DESCRIPTORS IN THE
; IDT FOR THE RESERVED INTERRUPTS
0018 A5 MOVSW ; GET A ROUTINE ENTRY POINT
; AND PUT IT IN THE OFFSET FIELD
0019 8B C3 MOV AX,BX ; GET THE SYSTEM CODE SEGMENT SELECTOR
001B AB STOSW ; AND PUT IT IN THE SELECTOR FIELD
001C 8B C2 MOV AX,DX ; GET THE INTERRUPT GATE BYTE
001E AB STOSW ; AND PUT IT IN THE ACCESS RIGHTS FIELD
001F 8B 0000 MOV AX,0 ; ZERO OUT
0022 AB STOSW ; THE RESERVED POSITIONS
0023 E2 F3 LOOP LOW_IDT ; AND REPEAT AS DIRECTED
;
0025 B9 00E0 MOV CX,256-32 ; 256 TOTAL - 32 DONE = WHATEVER IS LEFT
0028 BD 00A6 R MOV BP,OFFSET FREE_INTS ; THERE IS A COPY OF AN UNINITIALIZED
; INTERRUPT DESCRIPTOR AT FREE_INTS
;
PAGE
HIGH_IDT:
002B MOV SI,BP ; DS:SI --> FREE DESCRIPTOR
; (ES:DI LEFT OFF AT INT 32)
002D A5 MOVSW ; MOVE THE OFFSET OF THE IRET INSTRUCTION
002E A5 MOVSW ; MOVE THE CS SELECTOR
002F A5 MOVSW ; MOVE THE ACCESS RIGHTS BYTE
0030 AB STOSW ; ZERO OUT THE RESERVED WORD
0031 E2 F8 LOOP HIGH_IDT ; FILL THE REMAINDER OF THE TABLE
;
; INITIALIZE THE ENTRY POINTS FOR POST TEST
;
0033 26: C7 06 D1A0 0000 E MOV WORD PTR ES:(SYS_IDT_LOC+(032*DESC_LEN).ENTRY_POINT),OFFSET SYS_32
003A 26: C7 06 D1A8 0000 E MOV WORD PTR ES:(SYS_IDT_LOC+(033*DESC_LEN).ENTRY_POINT),OFFSET SYS_33
0041 26: C7 06 D1B0 0000 E MOV WORD PTR ES:(SYS_IDT_LOC+(034*DESC_LEN).ENTRY_POINT),OFFSET SYS_34
0048 26: C7 06 D1B8 0000 E MOV WORD PTR ES:(SYS_IDT_LOC+(035*DESC_LEN).ENTRY_POINT),OFFSET SYS_35
004F 26: C7 06 D1C0 0000 E MOV WORD PTR ES:(SYS_IDT_LOC+(036*DESC_LEN).ENTRY_POINT),OFFSET SYS_36
0056 26: C7 06 D1C8 0000 E MOV WORD PTR ES:(SYS_IDT_LOC+(037*DESC_LEN).ENTRY_POINT),OFFSET SYS_37
005D 26: C7 06 D1D0 0000 E MOV WORD PTR ES:(SYS_IDT_LOC+(038*DESC_LEN).ENTRY_POINT),OFFSET SYS_38
;
0064 C3 RET 0
;
PAGE
0065 IRET_ADDR LABEL WORD ; FOR UNINITIALIZED INTERRUPTS
0065 CF IRET
;
; EXTRNS FOR THE FIRST 32 SYSTEM INTERRUPTS
;
EXTRN EXC_00:NEAR
EXTRN EXC_01:NEAR
EXTRN EXC_02:NEAR
EXTRN EXC_03:NEAR
EXTRN EXC_04:NEAR
EXTRN EXC_05:NEAR
EXTRN EXC_06:NEAR
EXTRN EXC_07:NEAR
EXTRN EXC_08:NEAR
EXTRN EXC_09:NEAR
EXTRN EXC_10:NEAR
EXTRN EXC_11:NEAR
EXTRN EXC_12:NEAR
EXTRN EXC_13:NEAR
EXTRN EXC_14:NEAR
EXTRN EXC_15:NEAR
EXTRN EXC_16:NEAR
EXTRN EXC_17:NEAR
EXTRN EXC_18:NEAR
EXTRN EXC_19:NEAR
EXTRN EXC_20:NEAR
EXTRN EXC_21:NEAR
EXTRN EXC_22:NEAR
EXTRN EXC_23:NEAR
EXTRN EXC_24:NEAR
EXTRN EXC_25:NEAR
EXTRN EXC_26:NEAR
EXTRN EXC_27:NEAR

```

```

EXTRN  EXC_28:NEAR
EXTRN  EXC_29:NEAR
EXTRN  EXC_30:NEAR
EXTRN  EXC_31:NEAR
;
EXTRN  SYS_32:NEAR
EXTRN  SYS_33:NEAR
EXTRN  SYS_34:NEAR
EXTRN  SYS_35:NEAR
EXTRN  SYS_36:NEAR
EXTRN  SYS_37:NEAR
EXTRN  SYS_38:NEAR
;
PAGE
;
;       Entry points for the first 32 system interrupts
;
0066   SYS_IDT_OFFSETS      LABEL  WORD           ; INTERRUPTS AS DEFINED
;
0066  0000  E              DW      OFFSET EXC_00          ; EXCPT 00 - DIVIDE ERROR
0068  0000  E              DW      OFFSET EXC_01          ; EXCPT 01 - SINGLE STEP
006A  0000  E              DW      OFFSET EXC_02          ; EXCPT 02 - NMI, SYS REQ FOR D1
006C  0000  E              DW      OFFSET EXC_03          ; EXCPT 03 - BREAKPOINT
006E  0000  E              DW      OFFSET EXC_04          ; EXCPT 04 - INTO DETECT
0070  0000  E              DW      OFFSET EXC_05          ; EXCPT 05 - BOUND
0072  0000  E              DW      OFFSET EXC_06          ; EXCPT 06 - INVALID OPCODE
0074  0000  E              DW      OFFSET EXC_07          ; EXCPT 07 - PROCESSOR EXT NOT AVAIL
0076  0000  E              DW      OFFSET EXC_08          ; EXCPT 08 - DOUBLE EXCEPTION
0078  0000  E              DW      OFFSET EXC_09          ; EXCPT 09 - PROCESSOR EXT SEGMENT ERR
007A  0000  E              DW      OFFSET EXC_10          ; EXCPT 10 - STK PL BAD IN GATE TRANSFER
007C  0000  E              DW      OFFSET EXC_11          ; EXCPT 11 - SEGMENT NOT PRESENT
007E  0000  E              DW      OFFSET EXC_12          ; EXCPT 12 - STACK SEGMENT NOT PRESENT
0080  0000  E              DW      OFFSET EXC_13          ; EXCPT 13 - GENERAL PROTECTION
0082  0000  E              DW      OFFSET EXC_14
0084  0000  E              DW      OFFSET EXC_15
0086  0000  E              DW      OFFSET EXC_16          ; EXCPT 16 - PROCESSOR EXTENSION ERROR
0088  0000  E              DW      OFFSET EXC_17
008A  0000  E              DW      OFFSET EXC_18
008C  0000  E              DW      OFFSET EXC_19
008E  0000  E              DW      OFFSET EXC_20
0090  0000  E              DW      OFFSET EXC_21
0092  0000  E              DW      OFFSET EXC_22
0094  0000  E              DW      OFFSET EXC_23
0096  0000  E              DW      OFFSET EXC_24
0098  0000  E              DW      OFFSET EXC_25
009A  0000  E              DW      OFFSET EXC_26
009C  0000  E              DW      OFFSET EXC_27
009E  0000  E              DW      OFFSET EXC_28
00A0  0000  E              DW      OFFSET EXC_29
00A2  0000  E              DW      OFFSET EXC_30
00A4  0000  E              DW      OFFSET EXC_31
;
PAGE
;
;       FORMAT INTERRUPT DESCRIPTORS (GATES) 32 - 255
;
00A6  0065  R             FREE_INTS  DW      OFFSET IRET_ADDR      ; DESTINATION OFFSET
00A8  0040                DW      SYS_ROM_CS            ; DESTINATION SEGMENT
00AA  00 86                DB      0,INT_GATE           ; UNUSED BYTE, ACCESS RIGHTS BYTE
00AC                SIDT_BLD  ENDP
00AC                CODE     ENDS
;
END

```

0000

TITLE DSKETTE DATE 01-12-84 DISKETTE B10S
LIST
C INCLUDE SEGMENT.SRC
C CODE SEGMENT BYTE PUBLIC

PUBLIC DISK_INT_1
PUBLIC SEEK
PUBLIC DSKETTE_SETUP
EXTRN DDS:NEAR

```

-- INT 13
DISKETTE I/O
THIS INTERFACE PROVIDES ACCESS TO THE 5 1/4" DISKETTE DRIVES
320/360K DISKETTE DRIVES AND 1.2M DISKETTE DRIVES SUPPORTED
INPUT
(AH)=0  RESET DISKETTE SYSTEM
        HARD RESET TO NEG. PREPARE COMMAND, RECAL REQD ON ALL DRIVES
(AH)=1  READ THE STATUS OF THE SYSTEM INTO (AH)
        DISKETTE STATUS FROM LAST OP'N IS USED
REGISTERS FOR READ/WRITE/VERIFY/FORMAT
(DL) - DRIVE NUMBER (0-1 ALLOWED, VALUE CHECKED)
(DH) - HEAD NUMBER (0-1 ALLOWED, NOT VALUE CHECKED)
(CH) - TRACK NUMBER (NOT VALUE CHECKED)
        MEDIA DRIVE TRACK NUMBER
        320/360 320/360 0-39
        320/360 1.2M 0-39
        1.2M 1.2M 0-79
(CL) - SECTOR NUMBER (NOT VALUE CHECKED, NOT USED FOR FORMAT)
        MEDIA DRIVE SECTOR NUMBER
        320/360 320/360 1-8/9
        320/360 1.2M 1-8/9
        1.2M 1.2M 1-15
(AL) - NUMBER OF SECTORS (NOT VALUE CHECKED)
        MEDIA DRIVE MAX NUMBER OF SECTORS
        320/360 320/360 8/9
        320/360 1.2M 8/9
        1.2M 1.2M 15
(ES:BX) - ADDRESS OF BUFFER (REQUIRED FOR VERIFY)

(AH)=2  READ THE DESIRED SECTORS INTO MEMORY
(AH)=3  WRITE THE DESIRED SECTORS FROM MEMORY
(AH)=4  VERIFY THE DESIRED SECTORS
(AH)=5  FORMAT THE DESIRED TRACK
        FOR THE FORMAT OPERATION, THE BUFFER POINTER (ES,BX) MUST
        POINT TO THE COLLECTION OF DESIRED ADDRESS FIELDS FOR THE
        TRACK. EACH FIELD IS COMPOSED OF 4 BYTES, (C,H,R,N), WHERE
        C = TRACK NUMBER, H=HEAD NUMBER, R = SECTOR NUMBER, N= NUMBER
        OF BYTES PER SECTOR (00=128, 01=256, 02=512, 03=1024.)
        THERE MUST BE ONE ENTRY FOR EVERY SECTOR ON THE TRACK.
        THIS INFORMATION IS USED TO FIND THE REQUESTED SECTOR DURING
        READ/WRITE ACCESS.
        PRIOR TO FORMATTING A DISKETTE, FUNCTION CALL 17 OF THIS
        ROUTINE MUST BE INVOKED TO SET THE DISKETTE TYPE THAT IS TO
        BE FORMATTED.
        IN ORDER TO FORMAT 320/360K MEDIA IN EITHER A 320/360K OR
        1.2M DISKETTE DRIVE THE GAP LENGTH FOR FORMAT PARAMETER
        OF DISK_BASE MUST BE CHANGE TO 050H. ALSO THE EOT
        PARAMETER (LAST SECTOR ON TRACK) MUST BE SET TO THE
        DESIRED NUMBER OF SECTORS/TRACK - 8 FOR 320K, 9 FOR 360K.
        DISK_BASE IS POINTED TO BY DISK POINTER LOCATED AT
        ABSOLUTE ADDRESS 0:78.
        WHEN 320/360K FORMAT OPERATIONS ARE COMPLETE, THE PARAMETERS
        SHOULD BE RESTORED TO THEIR RESPECTIVE INITIAL VALUES.
(AH)=15 READ DASH TYPE
REGISTERS
(AH) - ON RETURN IF CARRY FLAG NOT SET, OTHERWISE ERROR
        00 - DRIVE NOT PRESENT
        01 - DISKETTE, NO CHANGE LINE AVAILABLE
        02 - DISKETTE, CHANGE LINE AVAILABLE
        03 - FIXED DISK
(DL) - DRIVE NUMBER (0-1 ALLOWED, VALUE CHECKED)

(AH)=16 DISK CHANGE LINE STATUS
REGISTERS
(AH)=00 - DISK CHANGE LINE NOT ACTIVE
        06 - DISK CHANGE LINE ACTIVE & CARRY BIT ON
(DL) - DRIVE NUMBER (0-1 ALLOWED, VALUE CHECKED)

(AH)=17 SET DASH TYPE FOR FORMAT
REGISTERS
(AL) - 00 - NOT USED
        01 - DISKETTE 320/360K IN 320/360K DRIVE
        02 - DISKETTE 320/360K IN 1.2M DRIVE
        03 - DISKETTE 1.2M IN 1.2M DRIVE
(DL) - DRIVE NUMBER (0-1 ALLOWED, VALUE CHECKED;
        DO NOT USE WHEN DISKETTE ATTACH CARD USED)
DISK CHANGE STATUS IS ONLY CHECKED WHEN A 1.2M BYTE DISKETTE
DRIVE IS SPECIFIED. IF THE DISK CHANGE LINE IS FOUND TO BE
ACTIVE THE FOLLOWING ACTIONS TAKE PLACE:
        ATTEMPT TO RESET DISK CHANGE LINE TO INACTIVE STATE.
        IF ATTEMPT SUCCEEDS SET DASH TYPE FOR FORMAT AND RETURN DISK
        CHANGE ERROR CODE.
        IF ATTEMPT FAILS RETURN TIMEOUT ERROR CODE AND SET DASH TYPE
        TO A PREDETERMINED STATE INDICATING MEDIA TYPE UNKNOWN.
        IF THE DISK CHANGE LINE IN INACTIVE PERFORM SET DASH TYPE FOR FORMAT.
DATA VARIABLE -- DISK POINTER
DOUBLE WORD POINTER TO THE CURRENT SET OF DISKETTE PARAMETERS
OUTPUT
AH = STATUS OF OPERATION
STATUS BITS ARE DEFINED IN THE EQUATES FOR DISKETTE_STATUS
VARIABLE IN THE DATA SEGMENT OF THIS MODULE
CY = 0 SUCCESSFUL OPERATION (AH=0 ON RETURN, EXCEPT FOR READ DASH
TYPE_AH=(15)).
CY = 1 FAILED OPERATION (AH HAS ERROR REASON)
FOR READ/WRITE/VERIFY
DS,BX,DX,CH,CL PRESERVED
NOTE: IF AN ERROR IS REPORTED BY THE DISKETTE CODE, THE APPROPRIATE
ACTION IS TO RESET THE DISKETTE, THEN RETRY THE OPERATION.
ON READ ACCESSES, NO MOTOR START DELAY IS TAKEN, SO THAT
THREE RETRIES ARE REQUIRED ON READS TO ENSURE THAT THE
PROBLEM IS NOT DUE TO MOTOR START-UP.

```

DISKETTE STATE MACHINE - ABSOLUTE ADDRESS 40:90 & 91
(DRIVE 0 - 90, DRIVE 1 - 91)
BITS

7	6	5	4	3	2	1	0
1	1	1	1	1	1	1	1

SECTION 5

```

RESERVED
--PRESENT STATE
000: 360K IN 1.2M DRIVE UNESTABLISHED
001: 360K IN 1.2M DRIVE UNESTABLISHED
002: 1.2M IN 1.2M DRIVE UNESTABLISHED
003: 360K IN 360K DRIVE ESTABLISHED
004: 360K IN 1.2M DRIVE ESTABLISHED
005: 1.2M IN 1.2M DRIVE ESTABLISHED

----->>> MEDIA/DRIVE ESTABLISHED
----->>> DOUBLE STEPPING REQUIRED (360K IN 1.2M DRIVE)
----->>> DATA TRANSFER RATE FOR THIS DRIVE:

00: 500 KBS
01: 300 KBS
10: 250 KBS
11: RESERVED

STATE OPERATION STARTED - ABSOLUTE ADDRESS 40:92 & 93
(DRIVE 0 - 92, DRIVE 1 - 93)
PRESENT CYLINDER NUMBER - ABSOLUTE ADDRESS 40:94 & 95
(DRIVE 0 - 94, DRIVE 1 - 95)
-----
PUBLIC DISKETTE_IO_1 ASSUME CS:CODE, DS:DATA, ES:DATA
DISKETTE_IO_1 PROC FAR

0000 FB STI ;>>> ENTRY POINT FOR ORG 0EC59H
0001 53 PUSH BX ; INTERRUPTS BACK ON
0002 51 PUSH CX ; SAVE ADDRESS
0003 1E PUSH DS ; SAVE SEGMENT REGISTER VALUE
0004 56 PUSH SI ; SAVE ALL REGISTERS DURING OPERATION
0005 57 PUSH DI
0006 55 PUSH BP
0007 52 PUSH DX
0008 8B EC MOV BP,SP ; SET UP POINTER TO HEAD PARM
000A BE ---- R MOV SI,DATA
000D 8E DE MOV DS,SI ; SET DATA REGION
000F 80 FC 01 CMP AH,1 ; CHECK FOR RESET AND STATUS OPERATIONS
0012 76 0F JBE R4 ; BYPASS DRIVE CHECK IF YES

0014 80 FA 01 ;
0017 76 0A JBE R4 ; CHECK DRIVE NUMBER FOR VALIDITY
; IF VALID CONTINUE

0019 C6 06 0041 R 01 R5: MOV DISKETTE_STATUS,BAD_CMD ; INVALID DRIVE ADDRESS, TERMINATE
001E BE 0000 MOV SI,0 ; INSURE THAT RETURN STATUS GETS SETUP
0021 EB 49 JMP SHORT OK ; GO TERMINAL COMMAND

0023 50 ;
0024 EB 010C R R4: PUSH AX ; SAVE ORIGINAL OPERATION FOR RETRY LATER ON
0027 5E CALL R1 ; CALL THE REST TO ENSURE DS RESTORED
0028 8B D6 MOV DX,SI ; RESTORE ORIGINAL OPERATION FOR RETRY
002A 80 FE 01 CMP DH,1 ; GET ORIGINAL OPERATION FOR TESTING
002D 76 3D JBE OK ; SEE IF IT IS A RESET OR STATUS OPERATION
; BYPASS STATE UPDATE

002F F6 06 00F8 R 01 ;
0034 74 36 TEST HF_CNTRL,DUAL ; GO DETERMINE TYPE OF CONTROLLER CARD
; DISKETTE ATTACH CARD

0036 80 FE 15 ;
0039 73 31 CMP DH,15H ; READ DISK CHANGE STATUS OR DISK TYPE COMMAND
; IF YES, BYPASS STATE PROCESSING

003B 8B 56 00 ;
003E 32 FF MOV DX,[BP] ; RESTORE DRIVE PARAMETER
0040 8A DA MOV BH,BH ; SETUP ADDRESS TO MEDIA STATE FOR THIS DRIVE
0042 8A 26 0041 R MOV AH,DISKETTE_STATUS ; GET STATUS OF OPERATION
0046 0A E4 OR AH,AH ; SEE IF ANY ERRORS
0048 75 4C JNZ RETRY ; JUMP TO CHECK FOR MEDIA CHANGE

004A 8A AF 0090 R MOV AH,DSK_STATE[BX] ; GET MEDIA STATE OF DRIVE
004E F6 CA 10 TEST AH,DETERMINED ; SEE IF MEDIA STATE SET ALREADY
0051 75 14 JNZ ; IF SET, DONT CHANGE STATE

0053 8A CC MOV CL,AH ; GET PRESENT STATE
0055 80 E1 07 AND CL,STATE_MSK ; ISOLATE STATE NUMBER
0058 80 C1 03 ADD CL,3 ; ELEVATE STATE TO SET ALREADY
005B 80 E4 F8 AND AH,REV_STATE ; CLEAR OUT STATE NUMBER
005E 0A E1 OR AH,CL ; SET NEW STATE NUMBER
0060 80 CC 10 AND AH,DETERMINED ; MAKE MEDIA STATE SET
0063 88 AF 0090 R MOV DSK_STATE[BX],AH ; SAVE IN DRIVE STATE INDICATOR
0067 C6 87 0092 R 00 OK2: MOV DSK_STATE[BX+2],0 ; CLEAR ORIGINAL STATE OPERATION STARTED IN
006C 8B 0040 OK: MOV BX,4 ; GET THE MOTOR WAIT PARAMETER
006F 8B D6 MOV DX,SI ; GET ORIGINAL OP AGAIN
0071 50 PUSH AX ; SAVE RETURN VALUE
0072 E8 0382 R CALL GET_PARM
0075 8B 26 0040 R MOV MOTOR_COUNT,AH ; SET THE TIMER COUNT FOR THE MOTOR
0079 58 POP AX ; RESTORE RETURN VALUE
007A 80 FE 15 CMP DH,015H ; SEE IF READ DASD OPERATION
007D 75 05 JNE R20 ; IF NOT BYPASS

007F 86 E0 ;
0081 F8 XCHG AH,AL ; PUT RESULT IN AH
0082 EB 08 CLC ; SET SUCCESSFUL OPERATION
; GO LEAVE

0084 8A 26 0041 R R20: MOV AH,DISKETTE_STATUS ; GET STATUS OF OPERATION
0088 80 FC 01 CMP AH,1 ; SET THE CARRY FLAG TO INDICATE
008B F5 CMC ; SUCCESS OR FAILURE
R19: POP DX ; RESTORE ALL REGISTERS
008D 5D POP BP
008E 5F POP DI
008F 5E POP SI
0090 F POP DS
0091 59 POP CX
0092 5B POP BX ; RECOVER ADDRESS
0093 CA 0002 RET 2 ; THROW AWAY SAVED FLAGS

0096 80 3E 0041 R 06 RETRY: CMP DISKETTE_STATUS,MEDIA_CHANGE ; CHECK FOR DISK CHANGE ERROR
0098 74 54 JE OK1 ; TRUE ERROR DONT RETRY

009D 8A AF 0090 R MOV AH,DSK_STATE[BX] ; GET MEDIA STATE OF DRIVE
00A1 80 E4 07 AND AH,STATE_MSK ; ISOLATE STATE NUMBER
00A4 80 FC 03 CMP AH,3 ; SEE IF IN STATE 3
00A7 73 BE JAE OK2 ; IF ESTABLISHED STATE THEN TRUE ERROR

----- HANDLE STATES 0, 1 & 2

00A9 FE C4 ;
00AB 80 FC 03 CMP AH,3 ; TRY NEXT STATE
00AD E5 02 JNE R2' ; SEE IF OVERFLOW IN NON-ESTABLISHED STATES
; SKIP RESET TO BEGINNING IF YES

00B0 84 0 ;
00B2 8A AF 0092 R R2: MOV AH,0 ; NEXT STATE TO TRY AFTER OVERFLOW
00B6 80 E5 07 MOV CH,DSK_STATE[BX+2] ; GET START RETRY STATE
00B9 3A EC AND CH,STATE_MSK ; ISOLATE STATE BITS
CMP CH,AH ; ALL STATES TRIED

```



```

00BB 74 47 ; JE OK3 ; IF YES, THEN TRUE ERROR
;
;----- SETUP STATE INDICATOR FOR RETRY ATTEMPT
;
008D 8A AF 0090 R ; MOV CH,DSK_STATE[BX] ; GET STATE INDICATOR
00C1 DO C5 ; ROL CH,1 ; MOVE TRANSFER RATE TO LOW ORDER BITS
00C3 DO C5 ; ROL CH,1 ; *
00C5 80 E5 03 ; AND CH,TRAN_MSK ; ISOLATE TRANSFER RATE BITS
00C8 FE CD ; DEC CH ; CONVERT TO NEXT RATE
00CA 80 FF FF ; CMP CH,OFFH ; SEE IF OVERFLOW OCCURRED
00CD 75 02 ; JNE R3 ; JUMP IF NO OVERFLOW
;
00CF B5 02 ; MOV CH,XRATE ; SET TO NEXT RATE
00D1 DO CD R3: ROR CH,1 ; PUT TRANSFER BITS BACK WHERE THEY BELONG
00D3 DO CD ; ROR CH,1 ; *
00D5 80 FC 01 ; CMP AH,1 ; SEE IF THIS STATE REQUIRES DOUBLE STEP
00D8 75 03 ; JNE R9 ; IF NOT, BYPASS SETTING DOUBLE STEP
;
00DA 80 CD 20 ; OR CH,DOUBLE_STEP ; TURN ON DOUBLE STEP REQUIRED
00DD 0A E5 ; OR AH,CH ; COMBINE WITH STATE TO MAKE NEW INDICATOR
00DF 8E A7 0090 R ; MOV DSK_STATE[BX],AH ; SAVE AS NEW INDICATOR
;
;----- SETUP FOR ACTUAL RETRY OPERATION
;
00E3 8B 56 00 ; MOV DX,[BP] ; RESTORE PARAMETERS FROM STACK
00E6 8B 4E 0A ; MOV CX,[BP+10] ; *
00E9 8B 5E 0C ; MOV BX,[BP+12] ; *
00EC 8B C6 ; MOV AX,S1 ; *
00EE E9 0023 R ; JMP R4 ; GO RETRY OPERATION
;
00F1 8B 56 00 ; OK1: MOV DX,[BP] ; RESTORE DRIVE PARAMETER
00F4 EB 0604 R ; CALL READ_DSKCHNG ; GO READ DISK CHANGE LINE STATUS
00F7 75 03 ; JNZ OK4 ; IF ACTIVE, NO DISKETTE IN DRIVE, TIMEOUT
;
00F9 E9 0067 R ; JMP OK2 ; IF NOT ACTIVE, DISKETTE IN DRIVE, DISK CHANGE
;
00FC C6 06 0041 R 80 ; OK4: MOV DISKETTE_STATUS,TIME_OUT ; INDICATE TIMEOUT IF DRIVE EMPTY
0101 E9 0067 R ; JMP OK2
;
0104 C6 87 0090 R 80 ; OK3: MOV DSK_STATE[BX],POA_START ; ERROR PUT STATE AT POWER ON ASSUMPTION
0109 E9 0067 R ; JMP OK2
;
010C ; DISKETTE_10_1 ENDP
;
;----- DETERMINE NEW MEDIA TYPE, NEED TO RESET DISK CHANGE LINE HERE
;
010C ; J1 PROC NEAR
010E 80 FC 01 ; CMP AH,1 ; TEST FOR RESET AND STATUS OPERATION
010F 76 76 ; JBE ; BYPASS STATE CHECK AND UPDATE
;
0111 F6 06 008F R 01 ; TEST HF_CNTRL,DUAL ; GO DETERMINE TYPE OF CONTROLLER CARD
0116 74 11 ; JZ ; DISKETTE ATTACH CARD
;
0118 80 FC 15 ; CMP AH,15H ; TEST FOR DISK CHANGE STATUS OR DISK TYPE
011B 73 6A ; JAE ; BYPASS STATE CHECK AND UPDATE
;
011D 50 ; PUSH AX ; SAVE ORIGINAL PARAMETERS
011E 53 ; PUSH BX ; SAVE PARAMETERS
011F 51 ; PUSH CX ; *
0120 52 ; PUSH DX ; *
0121 EB 0604 R ; CALL READ_DSKCHNG ; GO READ DISK CHANGE LINE STATE
0124 74 0C ; JZ J11 ; BYPASS HANDLING DISK CHANGE LINE
;
0126 E9 05E2 R ; JMP J1F ; HANDLE DISK CHANGE LINE ACTIVE
;
0129 50 ; J1A: PUSH AX ; SAVE ORIGINAL PARAMETERS
012A 53 ; PUSH BX ; SAVE PARAMETERS
012B 51 ; PUSH CX ; *
012C 52 ; PUSH DX ; *
012D EB 0604 R ; CALL READ_DSKCHNG ; SELECT DRIVE FOR DISKETTE ATTACH CARD
0130 EB 51 ; JMP ; IGNORE DISK CHANGE STATUS
;
0132 8A 87 0090 R ; J11: MOV AL,DSK_STATE[BX] ; GET MEDIA STATE INFORMATION FOR DRIVE
0136 0A CD ; OR AL,AL ; CHECK FOR NO STATE INFORMATION AT ALL
0138 75 06 ; JNZ J1D ; IF INFORMATION DONT DEFAULT
;
013A 80 80 ; MOV AL,POA_START ; GET DEFAULT TO STATE 0
013C 8E 87 0090 R ; MOV DSK_STATE[BX],AL ; SET UP DEFAULT TO STATE 1
;
0140 3C 61 ; J1D: CMP AL,POA_DUAL ; SEE IF DOUBLE STEP RATE
0142 75 1E ; JNE ; BYPASS TRACK CHECK
;
0144 8B 4E 0A ; MOV CX,[BP+10] ; GET ORIGINAL TRACK PARAMETER
0147 80 FD 28 ; CMP CH,40 ; SEE IF TRACK IS PAST END OF DISKETTE(320)
014A 72 16 ; JB J1G ; GO TRY OPERATION AT THIS STATE IF NOT
;
014C C6 87 0090 R 02 ; MOV DSK_STATE[BX],02H ; SET NEXT STATE TO TRY IN ALGORITHM
0151 B0 02 ; MOV AL,02 ; PUT NEW STATE IN WORKING REGISTER
0153 8A B7 0092 R ; MOV DH,DSK_STATE[BX+2] ; GET OPERATION START STATE
0157 0A F6 ; OR DH,DH ; CHECK FOR OPERATION START
0159 75 13 ; JNZ J1C ; IF STARTED PREVIOUSLY, BYPASS SETTING IT UP
;
015B C6 87 0092 R 61 ; MOV DSK_STATE[BX+2],POA_DUAL ; SETUP STARTING STATE
0160 EB 0C ; JMP ; BYPASS NEXT STEP ALREADY DONE
;
0162 8A 97 0092 R ; J1G: MOV DL,DSK_STATE[BX+2] ; GET START MEDIA STATE
0166 0A D2 ; OR DL,DL ; SEE IF THIS IS ORIGINAL OPERATION OR A RETRY
0168 75 04 ; JNZ J1C ; IF RETRY IGNORE
;
016A 88 87 0092 R ; MOV DSK_STATE[BX+2],AL ; SAVE AS STARTING DATA RATE
016E 8A 0E 008B R ; J1C: MOV CL,LAstrate ; GET LAST DATA RATE SELECTED
0172 3A C1 ; MOV AL,CL ; COMPARE TO LAST OPERATION
0174 74 0D ; JNE ; IF SAME DONT SELECT NEW TRANSFER RATE
;
0176 A2 008B R ; MOV LAstrate,AL ; SAVE NEW TRANSFER RATE FOR NEXT CHECK
0179 DO CD ; ROL AL,1 ; MOVE TRANSFER RATE DATA TO LOW BITS
017B DO C0 ; ROL AL,1 ; *
017D 24 03 ; AND AL,TRAN_MSK ; CLEAR ALL BITS BUT DATA TRANSFER RATE BITS
017F BA 03F7 ; MOV DX,03F7H ; ADDRESS FLOPPY CONTROL REGISTER
0182 EE ; OUT DX,AL ; SET DATA TRANSFER RATE
;
0183 5A ; J1H: POP DX ; RESTORE PARAMETERS
0184 59 ; POP CX ; *
0185 58 ; POP BX ; *
0186 58 ; POP AX ; *
0187 8A F0 ; MOV DH,AL ; SAVE # SECTORS IN DH
0189 80 25 003F R 7F ; AND AH,AH ; MOTOR STATUS,07FH
018E 0A E4 ; OR AH,AH ; AH=0 ; INDICATE A READ OPERATION
0190 74 38 ; JZ DISK_RESET ; AH=1
0192 FE CC ; DEC AH ; *
0194 74 76 ; JZ DISK_STATUS ; *
0196 C6 06 0041 R 00 ; MOV DISKETTE_STATUS,0 ; RESET THE STATUS INDICATOR
019B FE CC ; DEC AH ; *
019D 74 6E ; JZ DISK_READ ; *
019F FE CC ; DEC AH ; *
01A1 75 03 ; JNZ ; *
01A3 E9 0240 R ; JMP DISK_WRITE

```

```

01A6          J2:          DEC          AH          ; TEST_DISK_VERF
01A6 FE CC          JZ          DISK_VERF          ; AH=4
01A8 74 6C          JZ          DEC          ; AH=5
01AA FE CC          JZ          DISK_FORMAT          ; AH=5
01AC 74 6C          SUB          AH,10H          ; AH=15H
01AE 80 EC 10       JNZ          J3          ; BYPASS DISK TYPE OPERATION
01B1 75 03          ;
01B3 E9 0698 R      JMP          DISK_TYPE          ; GO PERFORM DISK TYPE OPERATION
01B6 FE CC          J3:          DEC          AH          ; AH = 16H
01B8 75 03          JNZ          J4          ; BYPASS DISK CHANGE STATUS
;
01BA E9 0646 R      JMP          DISK_CHANGE          ; GO CHECK DISK CHANGE LINE STATUS
01BD FE CC          J4:          DEC          AH          ; AH = 17H
01BF 75 03          JNZ          J5          ; BAD COMMAND
;
01C1 E9 070D R      JMP          FORMAT_SET          ; GO SET MEDIA/DRIVE TYPE FOR FORMAT
;
01C4 C6 06 0041 R 01 J5:          MOV          DISKETTE_STATUS,BAD_CMD ; ERROR CODE, NO SECTORS TRANSFERRED
01C9 C3          RET          ; UNDEFINED OPERATION
01CA          J1          ENDP

```

;----- RESET THE DISKETTE SYSTEM

```

DISK_RESET      PROC NEAR
01CA          MOV          DX,03F2H          ; ADAPTER CONTROL PORT
01CB FA          CLJ          ; NO INTERRUPTS
01CE A0 003F R      MOV          AL,MOTOR_STATUS          ; WHICH MOTOR IS ON
01D1 24 3F          AND          AL,03FH          ; STRIP OFF UNWANTED BITS
01D3 81 04          MOV          CL,4          ; SHIFT COUNT
01D5 02 C0          ROL          AL,CL          ; MOVE MOTOR VALUE TO HIGH NIBBLE, DRIVE SELECT
;
01D7 0C 08          OR          AL,8          ; TO LOW NIBBLE
01D9 EE          OUT          DX,AL          ; TURN ON INTERRUPT ENABLE
01DA C6 06 003E R 00 MOV          SEEK_STATUS,0          ; RESET THE ADAPTER
01DF C6 06 0041 R 00 MOV          DISKETTE_STATUS,0          ; SET OK STATUS FOR ALL DRIVES
01E4 EB 0D          JMP          $+2          ; I/O WAIT STATE
01E6 0C 04          OR          AL,4          ; TURN OFF RESET
01E8 EE          OUT          DX,AL          ; TURN OFF THE RESET
01E9 FB          STI          ; REENABLE THE INTERRUPTS
01EA E8 051A R      CALL          CHK_STAT_2          ; DO SENSE INTERRUPT STATUS FOLLOWING RESET
01ED A0 0042 R      MOV          AL,REC_STATUS          ; IGNORE ERROR RETURN AND DO OWN TEST
01F0 3C C0          CMP          AL,0C0H          ; TEST FOR DRIVE READY TRANSITION
01F2 74 06          JZ          J7          ; EVERYTHING OK
01F4 80 0E 0041 R 20 OR          DISKETTE_STATUS,BAD_NEC ; SET ERROR CODE
01F9 C3          RET

```

;----- SEND SPECIFY COMMAND TO NEC

```

01FA          J7:          ; DRIVE_READY
01FA B4 03          MOV          AH,03H          ; SPECIFY COMMAND
01FC E8 03E2 R      CALL          NEC_OUTPUT          ; OUTPUT THE COMMAND
01FF BB 0001          CALL          BX,1          ; FIRST BYTE PARM IN BLOCK
0202 E8 0382 R      CALL          GET_PARM          ; TO THE NEC CONTROLLER
0205 BB 0003          MOV          BX,3          ; SECOND BYTE PARM IN BLOCK
0208 E8 0382 R      CALL          GET_PARM          ; TO THE NEC CONTROLLER
020B          RET          ; RESET_RE
020C          ; RETURN TO CALLER
DISK_RESET      ENDP

```

;----- DISKETTE STATUS ROUTINE

```

020C          DISK_STATUS      PROC NEAR
020C          RET
020D          DISK_STATUS      ENDP

```

;----- DISKETTE READ

```

DISK_READ      PROC NEAR
020D          MOV          AL,046H          ; READ COMMAND FOR DMA
020E          J9:          ; DISK_READ_CMD
020F          CALL          DMA_SETUP          ; SET UP THE DMA
0212 B4 E6          MOV          AH,0E6H          ; SET UP READ COMMAND FOR NEC CONTROLLER
0214 EB 36          JMP          SHORT RW_OPN          ; GO DO THE OPERATION
0216          DISK_READ      ENDP

```

;----- DISKETTE VERIFY

```

0216          DISK_VERIFY      PROC NEAR
0216 B0 42          MOV          AL,042H          ; VERIFY COMMAND FOR DMA
0218 EB F5          JMP          J9          ; DO AS IF DISK READ
021A          DISK_VERIFY      ENDP

```

;----- DISKETTE FORMAT

```

DISK_FORMAT      PROC NEAR
021A          OR          MOTOR_STATUS,WRITE_OP          ; INDICATE WRITE OPERATION
021A 80 0E 003F R 80 MOV          AL,04AH          ; WILL WRITE TO THE DISKETTE
021F B0 4A          MOV          AL,04AH          ; SET UP THE DMA
0221 E8 04CA R      CALL          DMA_SETUP          ; ESTABLISH THE FORMAT COMMAND
0224 B4 4D          MOV          AH,04DH          ; DO THE OPERATION
0226 EB 24          JMP          SHORT RW_OPN          ; CONTINUATION OF RW_OPN FOR FMT
0228          ; GET THE
0228          J10:          MOV          BX,7          ; GET THE
0228          CALL          GET_PARM          ; BYTES/SECTOR VALUE TO NEC
022B BB 0009          MOV          BX,9          ; GET THE
022C          CALL          GET_PARM          ; SECTORS/TRACK VALUE TO NEC
0231 E8 0382 R      MOV          BX,T5          ; GET THE
0234 BB 000F          MOV          BX,T5          ; GAP LENGTH VALUE TO NEC
0237 E8 0382 R      CALL          GET_PARM          ; GET THE FILLER BYTE
023A BB 0011          MOV          BX,T7          ; TO THE CONTROLLER
023D E9 032A R      JMP          J16
0240          DISK_FORMAT      ENDP

```

;----- DISKETTE WRITE ROUTINE

```

DISK_WRITE      PROC NEAR
0240          OR          MOTOR_STATUS,WRITE_OP          ; INDICATE WRITE OPERATION
0240 80 0E 003F R 80 MOV          AL,04AH          ; DMA WRITE COMMAND
0245 B0 4A          MOV          AL,04AH          ; DMA WRITE COMMAND
0247 E8 04CA R      CALL          DMA_SETUP          ; NEC COMMAND TO WRITE TO DISKETTE
024A B4 C5          MOV          AH,0C5H
024C          DISK_WRITE      ENDP

```

;----- ALLOW WRITE ROUTINE TO FALL INTO RW_OPN

```

;-----
; RW_OPN
; THIS ROUTINE PERFORMS THE READ/WRITE/VERIFY OPERATION
;-----
RW_OPN          PROC NEAR
024C          JNC          J11          ; TEST FOR DMA ERROR
024C 73 08          JNC          J11          ; SET ERROR
024E C6 06 0041 R 09 MOV          DISKETTE_STATUS,DMA_BOUNDARY ; NO SECTORS TRANSFERRED
0253 80 00          MOV          AL,0          ; RETURN TO MAIN ROUTINE
0255 C3          RET

```

```

0256          J11:          PUSH          AX          ; DO_RW_OPN
0256 50          ; SAVE THE COMMAND

```

;----- TURN ON THE MOTOR AND SELECT THE DRIVE

```

0257 51                                PUSH  CX                ; SAVE THE T/S PARMS
0258 8A CA                            MOV   CL,DL            ; GET DRIVE NUMBER AS SHIFT COUNT
025A 80 01                            MOV   AL,1            ; MASK FOR DETERMINING MOTOR BIT
025C D2 E0                            SAL   AL,CL           ; SHIFT THE MASK BIT
025E FA                                CLC                    ; NO INTERRUPTS WHILE DETERMINING MOTOR STATUS
025F 84 06 003F R                     TEST  AL,MOTOR_STATUS ; IS THIS MOTOR ON
-0263 74 0C                            JZ    R13              ; IF NOT GO TEST FOR WAIT NECESSARY

0265 80 3E 0040 R EC                   CMP   MOTOR_COUNT,0ECH ; SEE IF THE MOTOR HAS BEEN ON LONG ENOUGH
026A C6 06 0040 R FF                   MOV   MOTOR_COUNT,OFFH ; ENSURE MOTOR DOESNT TURN OFF DURING OPERATION
026F 72 42                            JB    J14              ; IS LESS THAN EC, THEN TURN ON NOT DUE TO
                                ; READING OF DISK CHANGE LINE, OTHERWISE
                                ; GO TEST FOR WAIT NECESSARY

0271 08 06 003F R                      R13: OR    MOTOR_STATUS,AL ; TURN ON THE CURRENT MOTOR
0275 B1 04                            CL   CL               ; SHIFT COUNT TO MOVE DRIVE TO HIGH NIBBLE
0277 80 26 003F R CF                   AND  MOTOR_STATUS,0CFH ; CLEAR ENCODED DRIVE SELECT BITS(4 & 5)
027C D2 C2                            ROL  DL,CL            ; MOVE DRIVE ENCODED BITS TO HIGH NIBBLE
027E 08 16 003F R                      OR   MOTOR_STATUS,DL ; SAVE AS SELECTED DRIVE
0282 D2 CA                            ROR  DL,CL            ; RESTORE
0284 FB                                STI                    ; INTERRUPTS BACK ON
0285 AD 003F R                          MOV   AL,MOTOR_STATUS ; GET MOTORS ON AND DRIVE SELECTED
0288 24 3F                            AND  AL,03FH          ; STRIP OFF UNWANTED BITS
028A D2 C0                            ROL  AL,CL            ; SHIFT BITS AROUND TO DESIRED POSITIONS
028C 0C 0C                            OR   AL,0CH           ; NO RESET, ENABLE DMA/INT
028E 52                                PUSH  SV               ; SAVE REG
028F BA 03F2                            MOV  DX,03F2H         ; CONTROL PORT ADDRESS
0292 EE                                OUT  DX,AL             ;
0293 5A                                POP  DX                ; RECOVER REGISTERS

;----- WAIT FOR MOTOR

0294 F8                                CLC                    ; CLEAR TIMEOUT INDICATOR
0295 88 90FD                            MOV  AX,909FDH        ; LOAD WAIT CODE & TYPE
0296 CD 15                            INT  15H              ; PERFORM OTHER FUNCTION
029A 72 17                            JC   J14              ; BYPASS TIMING LOOP IF TIMEOUT OCCURRED

029C BB 0014                            MOV  BX,20            ; GET THE MOTOR WAIT
029F E8 0382 R                          CALL  GET_PARM        ; PARAMETER
02A2 0A E4                            OR   AH,AH            ; TEST FOR NO WAIT
02A4 74 0D                            JZ   J14              ; TEST WAIT TIME
02A6 2B C9                            SUB  CX,CX            ; EXIT WITH TIME EXPIRED
02A8 E2 FE                            J13: LOOP J13         ; SET UP 1/8 SECOND LOOP TIME
                                ; WAIT FOR THE REQUIRED TIME

02AA B9 6D06                            MOV  CX,06D06H        ; *
02AD E2 FE                            R18: LOOP R18        ; *

02AF FE CC                            DEC  AH               ; DECREMENT TIME VALUE
02B1 75 F1                            JNZ  J12              ; ARE WE DONE YET

02B3 J14:                                ; MOTOR RUNNING
02B3 FB                                STI                    ; INTERRUPTS BACK ON FOR BYPASS WAIT
02B4 59                                POP  CX

;----- DO THE SEEK OPERATION

02B5 E8 041C R                          CALL  SEEK            ; MOVE TO CORRECT TRACK
02B8 58                                POP  AX               ; RECOVER COMMAND
02B9 8A FC                            MOV  BH,AH            ; SAVE COMMAND IN BH
02BB B6 00                            MOV  DH,0             ; SET NO SECTORS READ IN CASE OF ERROR
02BD 72 72                            JC   J17              ; IF ERROR, THEN EXIT AFTER MOTOR OFF
02BF BE 0331 R                          MOV  SI,OFFSET J17   ; DUMMY RETURN ON STACK FOR NEC OUTPUT
02C2 56                                PUSH SI               ; SO THAT IT WILL RETURN TO MOTOR OFF LOCATION

;----- SEND OUT THE PARAMETERS TO THE CONTROLLER

02C3 E8 03E2 R                          CALL  NEC_OUTPUT      ; OUTPUT THE OPERATION COMMAND
02C6 8A 66 01                            MOV  AH,[BP+1]        ; GET THE CURRENT HEAD NUMBER
02C9 D0 E4                            SAL  AH,1             ; MOVE IT TO BIT 2
02CB D0 E4                            SAL  AH,1             ;
02CD 80 E4 04                          AND  AH,4             ; ISOLATE THAT BIT
02D0 0A E2                            OR   AH,DL            ; OR IN THE DRIVE NUMBER
02D2 E8 03E2 R                          CALL  NEC_OUTPUT

;----- TEST FOR FORMAT COMMAND

02D5 80 FF 4D                           CMP  BH,04DH          ; IS THIS A FORMAT OPERATION
02D8 75 03                            JNE  J15              ; NO. CONTINUE WITH R/W/V
02DA E9 0228 R                          JMP  J10              ; IF SO, HANDLE SPECIAL

02DD 8A E5                                MOV  AH,CH            ; CYLINDER NUMBER
02DF E8 03E2 R                          CALL  NEC_OUTPUT      ; HEAD NUMBER FROM STACK
02E2 8A 66 01                            MOV  AH,[BP+1]        ; HEAD NUMBER FROM STACK
02E5 E8 03E2 R                          CALL  NEC_OUTPUT      ;
02E8 8A E1                                MOV  AH,CL            ; SECTOR NUMBER
02EA E8 03E2 R                          CALL  NEC_OUTPUT      ;
02ED BB 0007                            MOV  BX,7             ; BYTES/SECTOR PARM FROM BLOCK
02F0 E8 0382 R                          CALL  GET_PARM        ; TO THE NEC
02F3 B8 0009                            MOV  BX,9             ; EDT PARM FROM BLOCK
02F6 E8 0382 R                          CALL  GET_PARM        ; TO THE NEC
02F9 B8 5E 00                            MOV  BX,[BP]          ; RESTORE DRIVE NUMBER FROM PARMS
02FC 32 FF                                XOR  BH,BH            ; CLEAR HIGH ORDER INDEX REGISTER
02FE 8A AT 0090 R                       MOV  AH,DISK_STATE[BX]; GET DRIVE STATE VALUE
0302 F6 C4 10                           TEST AH,DETERMINED   ; SEE IF STATE ALREADY ESTABLISHED
0305 74 06                            JZ   DO               ; BYPASS STATE REDUCTION FOR GAP LENGTH

0307 80 E4 07                           AND  AH,07H          ; STRIP OFF HIGH BITS
030A 80 EC 03                           SUB  AH,03H          ; REDUCE STATES

030D 80 E4 07                           AND  AH,07H          ; STRIP OFF HIGH BITS
0310 80 FC 00                           CMP  AH,0             ; CHECK FOR DISKETTE ATTACH CARD OR 320 DRIVE
0313 75 04                            JNE  R16              ; IF NOT CHECK FOR NEXT STATE

0315 B4 2A                                MOV  AH,02AH          ; LOAD 320/360 DRIVE GAP LENGTH
0317 E8 0B                                JMP  SHORT R15        ; GO OUTPUT

0319 80 FC 01                           R16: MOV  AH,1         ; CHECK FOR 320 MEDIA IN 1.2 DRIVE
031C 75 04                            JNE  R17              ; IF NOT, THEN HANDLE 1.2 MEDIA IN 1.2 DRIVE

031E B4 23                                MOV  AH,023H          ; LOAD 320/360 MEDIA IN 1.2 DRIVE GAP LENGTH
0320 E8 02                                JMP  SHORT R15        ;

0322 B4 1B                                MOV  AH,01BH          ; LOAD 1.2 MEDIA IN 1.2 DRIVE GAP LENGTH
0324 E8 03E2 R                          R17: CALL NEC_OUTPUT ;
0327 B8 000D                            MOV  BX,13            ; DTL PARM FROM BLOCK
032A J16:                                ; RW_OPN_FINISH
032A E8 0382 R                          CALL  GET_PARM        ; TO THE NEC
032D 5E                                POP  SI               ; CAN NOW DISCARD THAT DUMMY RETURN ADDRESS

;----- LET THE OPERATION HAPPEN

032E E8 053B R                          CALL  WAIT_INT        ; WAIT FOR THE INTERRUPT
0331 J17:                                ; MOTOR_OFF
0331 72 45                            JC   J21              ; LOOK FOR ERROR

```

```

0333 EB 0580 R      CALL      RESULTS      ; GET THE NEC STATUS
0336 72 3F          JC          J20          ; LOOK FOR ERROR

;----- CHECK THE RESULTS RETURNED BY THE CONTROLLER

0338 FC            CLD          ; SET THE CORRECT DIRECTION
0339 BE 0042 R     MOV      SI,OFFSET NEC_STATUS ; POINT TO STATUS FIELD
033C AC            LODS      NEC_STATUS ; GET ST0
033D 24 C0        AND      AL,0COH    ; TEST FOR NORMAL TERMINATION
033F 74 3B        JZ         J22      ; OPN_OK
0341 3C 40        CMP      AL,0OH    ; TEST FOR ABNORMAL TERMINATION
0343 75 29        JNZ      J18      ; NOT ABNORMAL, BAD NEC

;----- ABNORMAL TERMINATION, FIND OUT WHY

0345 AC            LODS      NEC_STATUS ; GET ST1
0346 D0 E0        SAL      AL,1      ; TEST FOR EOT FOUND
0348 B4 04        MOV      AH,RECORD_NOT_FND ; RW_FAIL
034A 72 24        JC         J19          ; RW_FAIL
034C D0 E0        SAL      AL,1      ; TEST FOR CRC ERROR
034E D0 E0        SAL      AL,1      ; TEST FOR DMA OVERRUN
0350 B4 10        MOV      AH,BAD_CRC    ; RW_FAIL
0352 72 1C        JC         J19          ; RW_FAIL
0354 D0 E0        SAL      AL,1      ; TEST FOR RECORD NOT FOUND
0356 B4 08        MOV      AH,BAD_DMA    ; RW_FAIL
0358 72 16        JC         J19          ; RW_FAIL
035A D0 E0        SAL      AL,1      ; TEST FOR RECORD NOT FOUND
035C D0 E0        SAL      AL,1      ; RW_FAIL
035E B4 04        MOV      AH,RECORD_NOT_FN ; RW_FAIL
0360 72 0E        JC         J19          ; RW_FAIL
0362 D0 E0        SAL      AL,1      ; TEST FOR WRITE_PROTECT
0364 B4 03        MOV      AH,WRITE_PROTECT ; RW_FAIL
0366 72 08        JC         J19          ; TEST MISSING ADDRESS MARK
0368 D0 E0        SAL      AL,1      ; RW_FAIL
036A B4 02        MOV      AH,BAD_ADDR_MARK ; RW_FAIL
036C 72 02        JC         J19          ; RW_FAIL

;----- NEC MUST HAVE FAILED

036E B4 20          J18:          ; RW-NEC-FAIL
0370              MOV      AH,BAD_NEC ; RW-FAIL
0372 08 26 0041 R  J19:          OR      DISKETTE_STATUS,AH ; HOW MANY WERE REALLY TRANSFERRED
0374 EB 05CB R     CALL      NUM_TRANS ; RW_ERR
0377 C3            RET          ; RETURN TO CALLER

0378 EB 0580 R     J21:          ; RW_ERR_RES
037B C3            CALL      RESULTS ; FLUSH THE RESULTS BUFFER
RET

;----- OPERATION WAS SUCCESSFUL

037C EB 05CB R     J22:          ; OPN_OK
037E 32 E4        CALL      NUM_TRANS ; HOW MANY GOT MOVED
037F C3            XOR      AH,AH      ; NO ERRORS
0382              RET          ; NO ERRORS

RW_OPN          ENDP

;-----
; GET_PARM
; THIS ROUTINE FETCHES THE INDEXED POINTER FROM
; THE DISK_BASE BLOCK POINTED AT BY THE DATA
; VARIABLE DISK_POINTER
; A BYTE FROM THAT TABLE IS THEN MOVED INTO AH,
; THE INDEX OF THAT BYTE BEING THE PARM IN BX
; ENTRY --
; BX = INDEX OF BYTE TO BE FETCHED * 2
; IF THE LOW BIT OF BX IS ON, THE BYTE IS IMMEDIATELY
; OUTPUT TO THE NEC CONTROLLER
; EXIT --
; AH = THAT BYTE FROM BLOCK
;-----
0382              GET_PARM      PROC   NEAR
0382 1E            PUSH     DS          ; SAVE SEGMENT
0383 56            PUSH     SI          ; SAVE
0384 2B C0        SUB      AX,AX      ; ZERO TO AX
0386 8E 08        MOV      DS,AX
0388 C5 36 0078 R  LDS     SI,DISK_POINTER ; POINT TO BLOCK
038C D1 EB        SHR     BX,1        ; DIVIDE BX BY 2, AND SET FLAG FOR EXIT
038E 8A 20        MOV     AH,[SI+BX]   ; GET THE WORD
0390 5E          POP     SI          ; RESTORE
0391 1F          POP     DS          ; RESTORE SEGMENT
0392 9C          PUSHF ; SAVE RESULTS FOR EXIT
0393 83 FB 0A    ASSUME  DS:DATA     ; LOOK FOR MOTOR STARTUP DELAY PARM
0396 75 19        GMP     BX,10       ; BYPASS IF NOT PARM LOOKING FOR
;
0398 F6 06 003F R  TEST   MOTOR_STATUS,WRITE_OP ; IS THIS A WRITE
039D 74 09        JZ      GP1         ; NO, ENFORCE MINIMUM READ WAIT
;
039F 80 FC 08     CMP     AH,8        ; SEE IF AT LEAST A SECOND IS SPECIFIED
03A2 73 3A        JAE     GP2         ; IF YES, CONTINUE
;
03A4 B4 08        MOV     AH,8        ; FORCE A SECOND WAIT FOR MOTOR START
03A6 EB 36        JMP     SHORT GP2   ; CONTINUE
;
03A8 80 FC 05     CMP     AH,5        ; SEE IF A 625 MS WAIT ON READ
03AB 73 31        JAE     GP2         ; IF THERE GO CONTINUE
;
03AD B4 05        MOV     AH,5        ; ENFORCE A 625 MS WAIT
03AF EB 2D        JMP     SHORT GP2   ; CONTINUE
;
03B1 83 FB 09     CMP     BX,9        ; IS THIS HEAD SETTLE PARM
03B4 75 28        JNE     GP0         ; BYPASS IF NOT HEAD SETTLE
;
03B6 F6 06 003F R  TEST   MOTOR_STATUS,WRITE_OP ; SEE IF A WRITE OPERATION
03B8 74 21        JZ      GP2         ; IF NOT, DONT ENFORCE ANY VALUES
;
03BD 0A E4        OR      AH,AH       ; CHECK FOR ANY WAIT?
03BF 75 1D        JNE     GP2         ; IF THERE DONT ENFORCE
;
03C1 52          PUSH     DX          ; SAVE REGISTER
03C2 53          PUSH     BX          ; SAVE REGISTER
03C3 8B 96 00     MOV     DX,[BP]     ; GET ORIGINAL DRIVE REQUESTED
03C6 32 FF        XOR     BH,BH       ; SET UP ADDRESSING TO STATE INDICATOR
03C8 8A DA        MOV     BL,DL       ; *
03CA B4 0F        MOV     AH,HD12_SETTLE ; SPEC'ED HEAD SETTLE TIME FOR 1.2 DRIVE
03CC 8A 87 0090 R MOV     AL,DSK_STATE[BX] ; GET MEDIA/DRIVE STATE
03D0 5B          POP     BX          ; RESTORE
03D1 5A          POP     DX          ; RESTORE
03D2 24 07        AND     AL,STATE_MSK ; ISOLATE STATE NUMBER
03D4 75 04        JNZ     GP4         ; BRANCH IF STATES 1 THRU 5
;
03D6 B4 14        MOV     AH,HD320_SETTLE ; SPEC'ED HEAD SETTLE TIME FOR 320 DRIVE
03D8 EB 04        JMP     SHORT GP2   ; GO TO WAIT LOOP

```

```

03DA 3C 03      ;
03DC 74 F8      GP4:  CMP   AL,3          ; SEE IF STATE 3(320 DRIVE/320 MEDIA)
                   JE    GP3          ; GO REESTABLISH WAIT TIME
03DE 9D         ;
03DF 72 01      GP2:  POPF          ; RESTORE EXIT RESULTS
03E1 C3         JC    NEC_OUTPUT    ; IF FLAG SET, OUTPUT TO CONTROLLER
03E2             RET                ; RETURN TO CALLER
                   GET_PARM      ENDP
-----
; NEC_OUTPUT
; THIS ROUTINE SENDS A BYTE TO THE NEC CONTROLLER
; AFTER TESTING FOR CORRECT DIRECTION AND CONTROLLER READY
; THIS ROUTINE WILL TIME OUT IF THE BYTE IS NOT ACCEPTED
; WITHIN A REASONABLE AMOUNT OF TIME, SETTING THE DISKETTE STATUS
; ON COMPLETION
; INPUT
; (AH) BYTE TO BE OUTPUT
; OUTPUT
; CY = 0 SUCCESS
; CY = 1 FAILURE -- DISKETTE STATUS UPDATED
; IF A FAILURE HAS OCCURRED, THE RETURN IS MADE ONE LEVEL
; HIGHER THAN THE CALLER OF NEC_OUTPUT
; THIS REMOVES THE REQUIREMENT OF TESTING AFTER EVERY CALL
; OF NEC_OUTPUT
; (AL) DESTROYED
-----
03E2             NEC_OUTPUT      PROC   NEAR
03E2 52          PUSH  DX          ; SAVE REGISTERS
03E3 51          PUSH  CX
03E4 53          PUSH  BX
03E5 BA 03F4H   MOV   DX,03F4H    ; STATUS PORT
03E8 B3 02     MOV   BL,2        ; HIGH ORDER COUNTER
03EA 33 C9     XOR   CX,CX      ; COUNT FOR TIME OUT
03EC           R11:             ;
03EC EC           J23:             ;
03ED A8 40     IN    AL,DX          ; GET STATUS
03EF 74 11     TEST  AL,0A0H    ; TEST DIRECTION BIT
03F1 E2 F9     JZ    J23          ; DIRECTION OK
;
03F3 FE CB     DEC   BL          ; DECREMENT COUNTER
03F5 75 F3     JNZ  J24          ; REPEAT_TIL DELAY FINISHED
;
03F7           ;
03F7 80 0E 0041 R 80 J24:  OR    DISKETTE_STATUS,1 ; TIME ERROR
03FC 5B        POP   BX          ; RESTORE REGISTERS
03FD 59        POP   CX
03FE 5A        POP   DX          ; SET ERROR CODE AND RESTORE REGS
03FF 58        POP   AX          ; DISCARD THE RETURN ADDRESS
0400 F9        STC                ; INDICATE ERROR TO CALLER
0401 C3        RET
0402 B3 02     R12:  MOV   BL,2        ; HIGH ORDER COUNT
0404           J25:             ;
0404 33 C9     XOR   CX,CX      ; RESET THE COUNT
0406           J26:             ;
0406 EC           ;
0407 A8 80     IN    AL,DX          ; GET THE STATUS
0409 75 08     JNZ  J27          ; IS IT READY
;
040B E2 F9     LOOP J26          ; COUNT DOWN AND TRY AGAIN
;
040D FE CB     DEC   BL          ; DECREMENT COUNTER
040F 75 F3     JNZ  J25          ; REPEAT_TIL DELAY FINISHED
;
0411 EB E4     JMP   J24          ; ERROR CONDITION
0413           J27:             ;
0413 8A C4     MOV   AL,AH      ; OUTPUT
;
0415 B2 F5     MOV   AL,AH      ; GET BYTE TO OUTPUT
0417 EE     MOV   DX,03F5H ; DATA PORT
0418 5B     OUT   DX,AL      ; OUTPUT THE BYTE
0419 59     POP   BX          ; RECOVER REGISTERS
041A 5A     POP   CX          ; RECOVER REGISTERS
041B C3     POP   DX          ; CY = 0 FROM TEST INSTRUCTION
041C             RET
-----
; NEC_OUTPUT      ENDP
-----
; SEEK
; THIS ROUTINE WILL MOVE THE HEAD ON THE NAMED DRIVE
; TO THE NAMED TRACK. IF THE DRIVE HAS NOT BEEN ACCESSED
; SINCE THE DRIVE RESET COMMAND WAS ISSUED, THE DRIVE WILL BE
; RECALIBRATED.
; INPUT
; (DL) = DRIVE TO SEEK ON
; (CH) = TRACK TO SEEK TO
; OUTPUT
; CY = 0 SUCCESS
; CY = 1 FAILURE -- DISKETTE_STATUS SET ACCORDINGLY
; (AX) DESTROYED
-----
041C             SEEK          PROC   NEAR
041C B0 01     MOV   AL,1        ; ESTABLISH MASK FOR RECAL TEST
041E 51     PUSH  CX          ; SAVE INPUT VALUE
041F 8A CA     MOV   CL,DL      ; GET DRIVE VALUE INTO CL
0421 D2 C0     ROL   AL,CL      ; SHIFT IT BY THE DRIVE VALUE
0423 59     POP   CX          ; RECOVER TRACK VALUE
0424 84 06 003E R MOV   AL,SEEK_STATUS ; TEST FOR RECAL REQUIRED
0428 75 37     JNZ  J28          ; NO_RECAL
;
042A 08 06 003E R OR    SEEK_STATUS,AL ; TURN ON THE NO RECAL BIT IN FLAG
042E B4 07     MOV   AH,07H    ; RECALIBRATE COMMAND
0430 E8 03E2 R CALL  NEC_OUTPUT
0433 8A E2     MOV   AH,DL      ; OUTPUT THE DRIVE NUMBER
0435 E8 03E2 R CALL  NEC_OUTPUT    ; GET THE INTERRUPT AND SENSE INT STATUS
0438 E8 051A R CALL  CHK_STAT_2
043B 73 14     JNC  J28A         ; SEEK_COMPLETE
;
;----- ISSUE RECALIBRATE FOR 80 TRACK DISKETTES
;
043D C6 06 0041 R 00 MOV   DISKETTE_STATUS,0 ; CLEAR OUT INVALID STATUS
0442 B4 07     MOV   AH,07H    ; RECALIBRATE COMMAND
0444 E8 03E2 R CALL  NEC_OUTPUT
0447 8A E2     MOV   AH,DL      ; OUTPUT THE DRIVE NUMBER
0449 E8 03E2 R CALL  NEC_OUTPUT    ; GET THE INTERRUPT AND SENSE INT STATUS
044C E8 051A R CALL  CHK_STAT_2
044F 72 78     JC    J28A         ; SEEK_ERROR
;
0451           J28A:             ;
0451 F6 06 00BF R 01 TEST  HF_CNTRL_DUAL ; GO DETERMINE TYPE OF CONTROLLER CARD
0456 74 09     JZ    J28          ; DISKETTE ATTACH CARD
;
0458 32 FF     XOR   BH,BH      ; SET UP ADDRESSING TO STATE INDICATOR
045A 8A DA     MOV   BL,DL      ; *
045C C6 87 0094 R 00 MOV   DSK_TRK[BX],0 ; SAVE NEW CYLINDER AS PRESENT POSITION
;
;----- DRIVE IS IN SYNCH WITH CONTROLLER, SEEK TO TRACK
0461           J28:             ;

```

```

0461 32 FF          XOR   BH,BH          ; SET UP ADDRESSING TO STATE INDICATOR
0463 8A DA          MOV   BL,DL          ; *
0465 F6 06 008F R 01 TEST  HF_CNTRL,DUAL ; GO DETERMINE TYPE OF CONTROLLER CARD
046A 74 09          JZ    R7             ; DISKETTE ATTACH CARD

;
046C F6 87 0090 R 20 TEST  DSK_STATE[BX],DOUBLE_STEP ; CHECK FOR DOUBLE STEP REQUIRED
0471 74 02          JZ    R7             ; SINGLE STEP REQUIRED BYPASS DOUBLE

;
0473 D0 E5          SHL   CH,1          ; DOUBLE NUMBER OF STEP TO TAKE
0475
R7: 0475 3A AF 0094 R   CMP   CH,DSK_TRK[BX] ; SEEK IF ALREADY AT THE DESIRED TRACK
0479 74 3E          JE    J32           ; IF YES, DONT NEED TO SEEK

;
047B 88 AF 0094 R   MOV   DSK_TRK[BX],CH ; SAVE NEW CYLINDER AS PRESENT POSITION
047F B4 0F          MOV   AH,OFH        ; SEEK COMMAND TO NEC
0481 E8 03E2 R     CALL  NEC_OUTPUT    ;
0484 8A E2          MOV   AH,DL         ; DRIVE NUMBER
0486 E8 03E2 R     CALL  NEC_OUTPUT    ;
0489 8A E5          MOV   AH,CH         ; GET CYLINDER NUMBER
048B E8 03E2 R     CALL  NEC_OUTPUT    ;
048E E8 051A R     CALL  CHK_STAT_2    ; GET ENDING INTERRUPT AND SENSE STATUS
0491 F6 06 008F R 01 TEST  HF_CNTRL,DUAL ; GO DETERMINE TYPE OF CONTROLLER CARD
0496 74 09          JZ    RA            ; DISKETTE ATTACH CARD

;
0498 F6 87 0090 R 20 TEST  DSK_STATE[BX],DOUBLE_STEP ; CHECK FOR DOUBLE STEP REQUIRED
049D 74 02          JZ    RA            ; SINGLE STEP REQUIRED BYPASS DOUBLE

;
049F D0 ED          SHR   CH,1          ; SET BACK TO LOGICAL SECTOR
04A1
RA:
;----- WAIT FOR HEAD SETTLE

04A1 9C            PUSHF                ; SAVE STATUS FLAGS
04A2 BB 0012        MOV   BX,18         ; GET HEAD SETTLE PARAMETER
04A5 E8 0382 R     CALL  GET_PARM      ; *
04A8 51            PUSH  CX            ; SAVE REGISTER
04A9 B9 0320        MOV   CX,800        ; HEAD SETTLE
J29: 04AC 0A E4          OR    AH,AH         ; 1 MS LOOP
04AE 74 06          JZ    J30           ; TEST FOR TIME EXPIRED
04B0 E2 FE        LOOP J30            ; DELAY FOR 1 MS
04B2 FE CC        DEC  AH            ; DECREMENT THE COUNT
04B4 EB F3        JMP  J29            ; DO IT SOME MORE
J30: 04B6 59          POP  CX            ; RECOVER STATE
04B7 9D          POPF                ;
04B8 C3          RET                ; RETURN TO CALLER

;
J32: 04B9            ; SEEK_ERROR
04B9 F6 06 008F R 01 TEST  HF_CNTRL,DUAL ; GO DETERMINE TYPE OF CONTROLLER CARD
04BE 74 09          JZ    RB            ; DISKETTE ATTACH CARD

;
04C0 F6 87 0090 R 20 TEST  DSK_STATE[BX],DOUBLE_STEP ; CHECK FOR DOUBLE STEP REQUIRED
04C5 74 02          JZ    RB            ; SINGLE STEP REQUIRED BYPASS DOUBLE

;
04C7 D0 ED          SHR   CH,1          ; SET BACK TO LOGICAL SECTOR
04C9
RB: 04C9            RET                ; RETURN TO CALLER
04CB C3          SEEK  ENDP

;-----
; DMA_SETUP
; THIS ROUTINE SETS UP THE DMA FOR READ/WRITE/VERIFY
; OPERATIONS.
; INPUT (AL) = MODE BYTE FOR THE DMA
; (ES:BX) = ADDRESS TO READ/WRITE THE DATA
; OUTPUT (AX) DESTROYED
;-----
04CA            DMA_SETUP  PROC  NEAR
04CA 51            PUSH  CX            ; SAVE THE REGISTER
04CB FA          CLI                ; DISABLE INTERRUPTS DURING DMA SET-UP
04CC E6 0C        OUT  DMA+12,AL     ; SET THE FIRST/LAST F/F
04CE EB 00        JMP  S+2            ; WAIT FOR IO
04D0 E6 0B        OUT  DMA+11,AL     ; OUTPUT THE MODE BYTE
04D2 8C C0        MOV  AX,ES         ; GET THE ES VALUE
04D4 B1 04        MOV  MOV           ; SHIFT COUNT
04D6 D3 C0        ROL  AX,CL         ; ROTATE LEFT
04D8 8A E8        MOV  CH,AL         ; GET HIGHEST NYBBLE OF ES TO CH
04DA 24 F0        AND  AL,OFH        ; ZERO THE LOW NYBBLE FROM SEGMENT
04DC 03 C3        ADD  AX,BX         ; TEST FOR CARRY FROM ADDITION
04DE 73 02        JNC  J33           ; CARRY MEANS HIGH 4 BITS MUST BE INC
04E0 FE C5        INC  CH
J33: 04E2 50          PUSH  AX            ; SAVE START ADDRESS
04E3 E6 04        OUT  DMA+4,AL     ; OUTPUT LOW ADDRESS
04E5 EB 00        JMP  S+2            ; WAIT FOR IO
04E7 8A C4        MOV  AL,AH         ; SHIFT COUNT
04E9 E6 04        OUT  DMA+4,AL     ; OUTPUT HIGH ADDRESS
04EB 8A C5        MOV  AL,CH         ; GET HIGH 4 BITS
04ED EB 00        JMP  S+2            ; I/O WAIT STATE
04EF 24 0F        AND  AL,OFH        ;
04F1 E6 81        OUT  08H,AL        ; OUTPUT THE HIGH 4 BITS TO PAGE REGISTER

;----- DETERMINE COUNT
04F3 8A E6        MOV  AH,DH         ; NUMBER OF SECTORS
04F5 2A C0        SUB  AL,AL         ; TIMES 256 INTO AX
04F7 D1 E8        SHR  AX,1          ; SECTORS * 128 INTO AX
04F9 50          PUSH  AX            ;
04FA BB 0006        MOV  BX,6          ; GET THE BYTES/SECTOR PARM
04FD E8 0382 R     CALL  GET_PARM     ;
0500 8A CC        MOV  CL,AH         ; USE AS SHIFT COUNT (0=128, 1=256 ETC)
0502 58        POP  AX            ;
0503 D3 E0        SHL  AX,CL         ; MULTIPLY BY CORRECT AMOUNT
0505 48        DEC  AX            ; -1 FOR DMA VALUE
0506 50          PUSH  AX            ; SAVE COUNT VALUE
0507 E6 05        OUT  DMA+5,AL     ; LOW BYTE OF COUNT
0509 EB 00        JMP  S+2            ; WAIT FOR IO
050B 8A C4        MOV  AL,AH         ; HIGH BYTE OF COUNT
050D E6 05        OUT  DMA+5,AL     ;
050F FB          STI                ; RE-ENABLE INTERRUPTS
0510 59          POP  CX            ; RECOVER COUNT VALUE
0511 58          POP  AX            ; RECOVER ADDRESS VALUE
0512 03 C1        ADD  AX,CX         ; ADD TEST FOR 64K OVERFLOW
0514 59          POP  CX            ; RECOVER REGISTER
0515 B0 02        MOV  AL,2          ; MODE FOR 8237
0517 E6 0A        OUT  DMA+10,AL    ; INITIALIZE THE DISKETTE CHANNEL
0519 C3          RET                ; RETURN TO CALLER, CFL SET BY ABOVE IF ERROR
051A
DMA_SETUP  ENDP
;-----
; CHK_STAT_2
; THIS ROUTINE HANDLES THE INTERRUPT RECEIVED AFTER
; A RECALIBRATE, SEEK, OR RESET TO THE ADAPTER.
; THE INTERRUPT IS WAITED FOR, THE INTERRUPT STATUS SENSED,
; AND THE RESULT RETURNED TO THE CALLER.

```

```

; INPUT
; OUTPUT
;      CY = 0 SUCCESS
;      CY = 1 FAILURE -- ERROR IS IN DISKETTE_STATUS
;      (AX) DESTROYED
;-----
051A      CHK_STAT_2      PROC      NEAR
051A      E8 053B R      CALL      WAIT_INT      ; WAIT FOR THE INTERRUPT
0510      72 14          JC          J34          ; IF ERROR, RETURN
051F      B4 08          MOV      AH,08H        ; SENSE INTERRUPT STATUS COMMAND
0521      E8 03E2 R      CALL      NEC_OUTPUT     ; READ IN THE RESULTS
0524      E8 058D R      CALL      RESULTS       ; CHK2_RETURN
0527      72 0A          JC          J34          ; CHK2_RETURN
0529      A0 0042 R      MOV      AL,NEC_STATUS  ; GET THE FIRST STATUS BYTE
052C      24 60          AND      AL,060H       ; ISOLATE THE BITS
052E      3C 60          CMP      AL,060H       ; TEST FOR CORRECT VALUE
0530      74 02          JZ          J35          ; IF ERROR, GO MARK IT
0532      F8             CLC                    ; GOOD RETURN
0533
; J34:      RET                    ; RETURN TO CALLER
; J35:      OR      STC           DISKETTE_STATUS,BAD_SEEK ; CHK2_ERROR
;          RET                    ; ERROR RETURN CODE
053A      CHK_STAT_2      ENDP
;-----
; WAIT_INT
; THIS ROUTINE WAITS FOR AN INTERRUPT TO OCCUR
; A TIME OUT ROUTINE TAKES PLACE DURING THE WAIT, SO
; THAT AN ERROR MAY BE RETURNED IF THE DRIVE IS NOT READY
; INPUT
; OUTPUT
;      CY = 0 SUCCESS
;      CY = 1 FAILURE -- DISKETTE_STATUS IS SET ACCORDINGLY
;      (AX) DESTROYED
;-----
053B      WAIT_INT      PROC      NEAR
053B      FB             STI                    ; TURN ON INTERRUPTS, JUST IN CASE
053C      50             PUSH   AX             ; SAVE REGISTERS
053D      53             PUSH   BX             ; *
053E      51             PUSH   CX             ; *
053F      F8             CLC                    ; CLEAR TIMEOUT INDICATOR
0540      BB 9001        MOV      AX,09001H    ; LOAD WAIT CODE AND TYPE
0543      CD 15          INT      15H         ; PERFORM OTHER FUNCTION
0545      72 11          JC          J36A        ; BYPASS TIMING LOOP IF TIMEOUT OCCURRED
;
; J36:      MOV      BL,4           ; CLEAR THE COUNTERS
;          XOR      CX,CX         ; FOR 2 SECOND WAIT
;          TEST     SEEK_STATUS,INT_FLAG ; TEST FOR INTERRUPT OCCURRING
0550      75 0C          JNZ     J37          ; COUNT DOWN WHILE WAITING
0552      E2 F7          LOOP    BL           ; SECOND LEVEL COUNTER
0554      FE CB          DEC     BL           ;
0556      75 F3          JNZ     J36         ;
;
; J36A:     OR      STC           DISKETTE_STATUS,TIME_OUT ; NOTHING HAPPENED
;          STC                    ; ERROR RETURN
; J37:      PUSHF          ; SAVE CURRENT CARRY
;          AND      AND      26 003E R 7F ; TURN OFF INTERRUPT FLAG
;          POPF         SEEK_STATUS,NOT_INT_FLAG ; RECOVER CARRY
;          POP      CX           ; RECOVER REGISTERS
;          POP      BX           ; *
;          POP      AX           ; *
0568      RET                    ; GOOD RETURN CODE COMES FROM TEST INST
0569      WAIT_INT      ENDP
;-----
; DISK_INT
; THIS ROUTINE HANDLES THE DISKETTE INTERRUPT
; INPUT
; OUTPUT
;      THE INTERRUPT FLAG IS SET IS SEEK_STATUS
;-----
0569      DISK_INT_1    PROC      FAR
0569      FB             STI                    ;>>> ENTRY POINT FOR ORG 0EF57H
056A      1E             PUSH   DS           ; RE ENABLE INTERRUPTS
056B      50             PUSH   AX           ; SAVE REGISTERS
056C      E8 0000 E      CALL   DDS         ; *
056F      80 0E 003E R 80 OR      SEEK_STATUS,INT_FLAG ; SETUP DATA ADDRESSING
0574      B0 20          MOV      AL,20H     ; TURN ON INTERRUPT OCCURRED
0576      E6 20          OUT     20H,AL     ; END OF INTERRUPT MARKER
0578      BB 9101        MOV      AX,09101H  ; INTERRUPT CONTROL PORT
0578      CD 15          INT      15H         ; INTERRUPT POST CODE & TYPE
057D      58             POP     AX           ; GO PERFORM OTHER TASK
057E      1F             POP     AX           ; RECOVER REG
057F      CF             IRET          ; *
0580      DISK_INT_1    ENDP
;-----
; RESULTS
; THIS ROUTINE WILL READ ANYTHING THAT THE NEC CONTROLLER
; HAS TO SAY FOLLOWING AN INTERRUPT.
; INPUT
; OUTPUT
;      CY = 0 SUCCESSFUL TRANSFER
;      CY = 1 FAILURE -- TIME OUT IN WAITING FOR STATUS
;      NEC_STATUS AREA HAS STATUS BYTE LOADED INTO IT
;      (AH) DESTROYED
;-----
0580      RESULTS      PROC      NEAR
0580      FC             CLD                    ; POINTER TO DATA AREA
0581      BF 0042 R      MOV      DI,OFFSET NEC_STATUS ; POINTER TO DATA AREA
0584      51             PUSH   CX           ; SAVE COUNTER
0585      52             PUSH   DX           ;
0586      53             PUSH   BX           ;
0587      B3 07          MOV     BL,7       ; MAX STATUS BYTES
;-----
;----- WAIT FOR REQUEST FOR MASTER
R10:      MOV      BH,2       ; HIGH ORDER COUNTER
; J38:      MOV      BH,2       ; INPUT LOOP
;          XOR      CX,CX     ; COUNTER
;          MOV     DX,03F4H   ; STATUS PORT
;          J39:      IN      AL,DX ; WAIT FOR MASTER
;          GET STATUS
;          TEST     AL,080H   ; MASTER READY
;          JNZ     J40A      ; TEST_DIR
;          LOOP    J39       ; WAIT_MASTER
;
;          DEC     BH        ; DECREMENT HIGH ORDER COUNTER
0597      FE CF

```

```

0599 75 F0 ; JNZ J38 ; REPEAT TIL DELAY DONE
059B 80 0E 0041 R 80 ; OR DISKETTE_STATUS,TIME_OUT
05A0 J40: ; ; RESULTS ERROR
05A0 F9 ; ; SET ERROR RETURN
05A1 5B POP BX
05A2 5A POP DX
05A3 59 POP CX
05A4 C3 RET

;----- TEST THE DIRECTION BIT
05A5 EC J40A: IN AL,DX ; GET STATUS REG AGAIN
05A6 A8 40 ; TEST AL,040H ; TEST DIRECTION BIT
05A8 75 07 ; JNZ J42 ; OK TO READ STATUS
05AA J41: ; ; NEC FAIL
05AA 80 0E 0041 R 20 ; OR DISKETTE_STATUS,BAD_NEC
05AF EB EF ; JMP J40 ; RESULTS_ERROR

;----- READ IN THE STATUS
05B1 J42: ; ; INPUT_STAT
05B1 42 ; INC DX ; POINT AT DATA PORT
05B2 EC ; IN AL,DX ; GET THE DATA
05B3 88 05 ; MOV [DI],AL ; STORE THE BYTE
05B5 47 ; INC D1 ; INCREMENT THE POINTER
05B6 B9 0014 ; MOV CX,20 ; LOOP TO KILL TIME FOR NEC
05B9 E2 FE ; LOOP J43
05BB 4A ; DEC DX ; POINT AT STATUS PORT
05BC EC ; IN AL,DX ; GET STATUS
05BD A8 10 ; TEST AL,010H ; TEST FOR NEC STILL BUSY
05BF 74 06 ; JZ J44 ; RESULTS DONE
05C1 FE CB ; DEC BL ; DECREMENT THE STATUS COUNTER
05C3 75 C4 ; JNZ R10 ; GO BACK FOR MORE
05C5 EB C3 ; JMP J41 ; CHIP HAS FAILED

;----- RESULT OPERATION IS DONE
05C7 J44: ; ; RECOVER REGISTERS
05C7 5B POP BX
05C8 5A POP DX
05C9 59 POP CX
05CA C3 RET ; GOOD RETURN CODE FROM TEST INST

;-----
; NUM_TRANS THIS ROUTINE CALCULATES THE NUMBER OF SECTORS THAT
; WERE ACTUALLY TRANSFERRED TO/FROM THE DISKETTE
; INPUT (CH) = CYLINDER OF OPERATION
; (CL) = START SECTOR OF OPERATION
; OUTPUT (AL) = NUMBER ACTUALLY TRANSFERRED
; NO OTHER REGISTERS MODIFIED
;-----
05CB NUM_TRANS PROC NEAR
05CB A0 0045 R MOV AL,NEC_STATUS+3 ; GET CYLINDER ENDED UP ON
05CE 3A C5 CMP AL,CH ; SAME AS WE STARTED
05D0 A0 0047 R MOV AL,NEC_STATUS+5 ; GET ENDING SECTOR
05D3 74 0A JZ J45 ; IF ON SAME CYL, THEN NO ADJUST
05D5 BB 0008 MOV BX,8
05D8 EB 0382 R CALL GET_PARM ; GET EOT VALUE
05DB 8A C4 MOV AL,AH ; INTO AL
05DD FE C0 INC AL ; USE EOT+1 FOR CALCULATION
05DF 2A C1 SUB AL,CL ; SUBTRACT START FROM END
05E1 C3 RET
05E2 J45: ; ; ENDP
05E2 RESULTS ENDP
;-----
; HANDLE DISK CHANGE IF FOUND TO BE
; ACTIVE
05E2 C6 87 0090 R 61 J1F: MOV DSK_STATE[BX],POA_DUAL ; CLEAR STATE FOR THIS DRIVE

; THIS SEQUENCE OF SEEKS IS USED TO RESET DISKETTE CHANGE SIGNAL
05E7 EB 01CA R CALL DISK_RESET ; RESET NEC
05EA 8B 56 00 MOV DX,[BP] ; RESTORE DRIVE PARAMETER
05ED B5 01 MOV CH,01H ; MOVE TO CYLINDER 1
05EF EB 041C R CALL SEEK ; ISSUE SEEK
05F2 8B 56 00 MOV DX,[BP] ; RESTORE DRIVE PARAMETER
05F5 B5 00 MOV CH,00H ; MOVE TO CYLINDER 0
05F7 EB 041C R CALL SEEK ; ISSUE SEEK
05FA C6 06 0041 R 06 MOV DISKETTE_STATUS,MEDIA_CHANGE ; INDICATE MEDIA REMOVED FROM DRIVE
05FF 5A POP DX ; RESTORE PARAMETERS
0600 59 POP CX ; *
0601 5B POP BX ; *
0602 58 POP AX ; *
0603 C3 RET ; MEDIA CHANGE, GO DETERMINE NEW TYPE

;-----
; READ_DSKCHNG THIS ROUTINE READS THE STATE OF THE
; DISK CHANGE LINE
; ZERO FLAG:
; 0 - DISK CHANGE LINE INACTIVE
; 1 - DISK CHANGE LINE ACTIVE
;-----
0604 READ_DSKCHNG PROC NEAR
0604 32 FF XOR BH,BH ; CLEAR HIGH ORDER OFFSET
0606 8A DA MOV BL,DL ; LOAD DRIVE NUMBER AS OFFSET
0608 B0 01 AND AL,01 ; MASK FOR DETERMINING MOTOR BIT
060A 80 26 MOV MOTOR_STATUS,0CFH ; CLEAR ENCODED DRIVE SELECT BITS(4 & 5)
060F B1 04 MOV CL,4 ; SHIFT DRIVE NUMBER INTO HIGH NIBBLE
0611 D2 C3 ROL BL,CL ; SHIFT DRIVE NUMBER INTO HIGH NIBBLE
0613 08 1E MOV MOTOR_STATUS,BL ; ADD IN DRIVE NUMBER SELECTED FOR LATER USE
0617 D2 CB ROR BL,CL ; RESTORE DRIVE NUMBER
0619 8A CB MOV CL,BL ; RESTORE DRIVE NUMBER
061B D2 E0 SHL AL,CL ; FORM MOTOR ON BIT MASK
061D FA CLI ; NO INTERRUPTS WHILE DETERMINING MOTOR STATUS
061E 84 06 MOV TEST,MOTOR_STATUS ; TEST
0622 75 09 JNZ R8 ; DONT NEED TO SELECT DEVICE IF MOTOR ON

;
0624 OR MOTOR_STATUS,AL ; TURN ON CURRENT MOTOR
0628 MOV MOTOR_COUNT,0FFH ; SET LARGE COUNT DURING OPERATION
062D FB STI ; ENABLE INTERRUPTS AGAIN
062E BA 03F2 MOV DX,03F2H ; ADDRESS DIGITAL OUTPUT REGISTER
0631 A0 003F R MOV AL,MOTOR_STATUS ; GET DIGITAL OUTPUT REGISTER REFLECTION
0634 24 3F AND AL,03FH ; STRIP AWAY UNWANTED BITS
0636 B1 04 MOV CL,4 ; SHIFT COUNT
0638 D2 C0 ROR AL,CL ; PUT BITS IN DESIRED POSITIONS
063A 0C OC OR AL,0CH ; NO RESET, ENABLE DMA/INT
063C EE OUT DX,AL ; SELECT DRIVE
063D BA 03F7 MOV DX,03F7H ; ADDRESS DIGITAL INPUT REGISTER
0640 EB 00 JMP $+2 ; DELAY FOR SUPPORT CHIP

```



```

0642 EC          IN          AL,DX          ; INPUT DIR
0643 AB 80      TEST        AL,DSK_CHG     ; CHECK FOR DISK CHANGE LINE ACTIVE
0645 C3          RET         ; RETURN TO CALLER WITH ZERO FLAG SET
0646          READ_DSKCHNG ENDP
-----
; DISK CHANGE
; THIS ROUTINE RETURNS THE STATE OF THE
; DISK CHANGE LINE
; DISKETTE STATUS:
; 00 - DISK CHANGE LINE INACTIVE
; 06 - DISK CHANGE LINE ACTIVE
-----
0646          DISK_CHANGE PROC NEAR
0646 F6 06 00BF R 01 TEST      HF_CNTRL,DUAL ; GO DETERMINE TYPE OF CONTROLLER CARD
064B 74 29      JZ         DC2          ; DISKETTE ATTACH CARD, SET CHANGE LINE ACTIVE
;
064D 32 FF      ;
064F 8A DA      MOV        BH,BH          ; CLEAR HIGH ORDER OFFSET
0651 8A 87 0090 R MOV        BL,DL          ; LOAD DRIVE NUMBER AS OFFSET
0655 24 07      AND        AL,DSK_STATE[BX] ; GET MEDIA STATE INFORMATION FOR DRIVE
0657 3C 03      CMP        AL,STATE_MSK     ; ISOLATE STATE
0659 74 07      JNE         AL,3          ; CHECK FOR HRP1 DRIVE & NOT ESTABLISHED STATES
;
065B 72 0B      ;
065D EB 0604 R  CALL     READ_DSKCHNG ; GO CHECK STATE OF DISK CHANGE LINE
0660 74 05      JZ         FINIS          ; CHANGE LINE NOT ACTIVE, RETURN
;
0662 C6 06 0041 R 06 SETIT: MOV    DISKETTE_STATUS,MEDIA_CHANGE ; INDICATE MEDIA REMOVED FROM DRIVE
0667 C3          FINIS: RET     ; RETURN TO CALLER
;
0668 8A 87 0090 R  DC0: MOV    AL,DSK_STATE[BX] ; GET MEDIA STATE INFORMATION FOR DRIVE
066C 0A C0      OR         AL,AL          ; CHECK FOR NO DRIVE INSTALLED
066E 75 F2      JNZ        SETIT         ; IF DRIVE PRESENT, SET CHANGE LINE ACTIVE
;
0670 80 0E 0041 R 80 DC1: MOV    DISKETTE_STATUS,TIME_OUT ; SET TIMEOUT BECAUSE NO DRIVE PRESENT
0675 C3          RET         ; RETURN TO CALLER
;
0676 80 0E      DC2: MOV    AL,CMOSDSB_ADDR ; GET CMOS DIAGNOSTIC STATUS BYTE ADDRESS
0678 E6 70      OUT        CADR_PRT,AL     ; WRITE ADDRESS TO READ OUT TO CMOS
067A EB 00      JMP        S+2            ; DELAY
067C E4 71      IN         AL,CDATA_PRT  ; GET CMOS STATUS
067E A8 C0      TEST       AL,CMOS_GOOD   ; SEE IF BATTERY GOOD AND CHECKSUM VALID
0680 75 EE      JNZ        DC1          ; ERROR IF EITHER BIT ON
;
0682 80 10      MOV        AL,CMOSDSK_BYTE ; ADDRESS OF DSCKETE BYTE IN CMOS
0684 E6 70      OUT        CADR_PRT,AL     ; WRITE ADDRESS TO READ OUT TO CMOS
0686 EB 00      JMP        S+2            ; DELAY
0688 E4 71      IN         AL,CDATA_PRT  ; GET DSCKETE BYTE
068A 0A D2      OR         DL,DL          ; SEE WHICH DRIVE IN QUESTION
068C 75 04      JNZ        DC3          ; IF DRIVE 1, DATA ALREADY IN LOW NIBBLE
;
068E 81 04      MOV        CL,4           ; GET ROTATE COUNT TO SHIFT HIGH TO LOW NIBBLE
0690 D2 C8      ROR        AL,CL         ; EXCHANGE NIBBLES
0692 24 0F      AND        AL,LOWNIB     ; CLEAR AWAY UNDESIRE DRIVE DATA
0694 74 DA      JZ         DC3          ; NO DRIVE THEN SET TIMEOUT ERROR
;
0696 EB CA      JMP        JMP           ; DRIVE, ON 320/360K DRIVES SET DISK CHANGE
0698          DISK_CHANGE ENDP
-----
; DISK TYPE
; THIS ROUTINE IS USED TO EITHER ESTABLISH THE
; TYPE OF MEDIA/DRIVE TO BE USED IN THE NEXT
; OPERATION(FOR FORMAT ONLY) OR RETURN THE
; TYPE OF MEDIA/DRIVE INSTALLED AT THE DRIVE
; SPECIFIED
-----
0698          DISK_TYPE PROC NEAR
0698 F6 06 00BF R 01 TEST      HF_CNTRL,DUAL ; GO DETERMINE TYPE OF CONTROLLER CARD
069D 74 49      JZ         T2          ; DISKETTE ATTACH CARD, GO DO TYPE OPERATION
;
069F 32 FF      ;
06A1 8A DA      MOV        BH,BH          ; CLEAR HIGH ORDER OFFSET
06A3 8A A7 0090 R MOV        BL,DL          ; LOAD DRIVE NUMBER AS OFFSET
;
06A7 F6 C4 10   TEST      AH,DETERMINED ; SEE IF MEDIA/DRIVE TYPE ALREADY ESTABLISHED
06AA 74 0B      JZ         T5          ; IF NOT, GO RETURN ZERO VALUE
;
06AC 80 E4 07   AND       AH,STATE_MSK   ; STRIP OFF HIGH ORDER BITS
06AF 80 EC 03   SUB       AH,03H        ; CONVERT TO TYPE FOR OUTPUT
06B2 75 0C      JNZ        T7          ; SKIP IF NOT 320/360 DRIVE AND MEDIA
;
06B4 80 01     MOV        AL,NOCHGLN    ; INDICATE NO CHANGE LINE AVAILABLE
06B6 C3          RET         ; RETURN TO CALLER
;
06B7 0A E4     OR         AH,AH         ; CHECK FOR NO DRIVE
06B9 74 2A     JZ         T5          ; IF NONE GO INDICATE SUCH TO CALLER
;
06BB 80 E4 07 AND       AH,STATE_MSK   ; STRIP OFF HIGH ORDER BITS
06BE 74 03     JZ         T7          ; IF STATE 0 CHECK CMOS
;
06C0 80 02     MOV        AL,CHGLN     ; 1,2 DRIVE
06C2 C3          RET         ; RETURN TO CALLER
;
06C3 80 0E     TA: MOV    AL,CMOSDSB_ADDR ; GET CMOS DIAGNOSTIC STATUS BYTE ADDRESS
06C5 E6 70     OUT        CADR_PRT,AL     ; WRITE ADDRESS TO READ OUT TO CMOS
06C7 EB 00     JMP        S+2            ; DELAY
06C9 E4 71     IN         AL,CDATA_PRT  ; GET CMOS STATUS
06CB A8 C0     TEST       AL,CMOS_GOOD   ; SEE IF BATTERY GOOD AND CHECKSUM VALID
06CD 75 16     JNZ        T1          ; ERROR IF EITHER BIT ON
;
06CF 80 10     MOV        AL,CMOSDSK_BYTE ; ADDRESS OF DSCKETE BYTE IN CMOS
06D1 E6 70     OUT        CADR_PRT,AL     ; WRITE ADDRESS TO READ OUT TO CMOS
06D3 EB 00     JMP        S+2            ; DELAY
06D5 E4 71     IN         AL,CDATA_PRT  ; GET DSCKETE BYTE
06D7 0A D2     OR         DL,DL          ; SEE WHICH DRIVE IN QUESTION
06D9 75 04     JNZ        TB          ; IF DRIVE 1, DATA ALREADY IN LOW NIBBLE
;
06DB 81 04     MOV        CL,4           ; GET ROTATE COUNT TO SHIFT HIGH TO LOW NIBBLE
06DD D2 C8     ROR        AL,CL         ; EXCHANGE NIBBLES
06DF 24 0F     AND        AL,LOWNIB     ; CLEAR AWAY UNDESIRE DRIVE DATA
06E1 3C 03     CMP        AL,3          ; SEE IF UNDEFINED DISKETTE TYPE
06E3 72 02     JNB        TB          ; RETURN IF NOT, RESULTS IN AL
;
06E5 32 C0     T1: XOR     AL,AL          ; STATE NO DRIVE PRESENT OR UNKNOWN
06E7 C3          RET     ; RETURN TO CALLER
;
06E9 80 0E     T2: MOV    AL,CMOSDSB_ADDR ; GET CMOS DIAGNOSTIC STATUS BYTE ADDRESS
06EB E6 70     OUT        CADR_PRT,AL     ; WRITE ADDRESS TO READ OUT TO CMOS
06ED EB 00     JMP        S+2            ; DELAY
06EF E4 71     IN         AL,CDATA_PRT  ; GET CMOS STATUS
06F0 A8 C0     TEST       AL,CMOS_GOOD   ; SEE IF BATTERY GOOD AND CHECKSUM VALID
06F2 75 F1     JNZ        T1          ; ERROR IF EITHER BIT ON
;
06F4 80 10     MOV        AL,CMOSDSK_BYTE ; ADDRESS OF DSCKETE BYTE IN CMOS
06F6 E6 70     OUT        CADR_PRT,AL     ; WRITE ADDRESS TO READ OUT TO CMOS

```



```

07E4 B5 0A      MOV     CH,QUIET_SEEK ; GET TRACK AT PRESENTLY
07E5 33 F6      XOR     SI,SI          ; CLEAR SEEK COUNTER
07E6 FE CD      SUP3:  DEC     CH        ; SEEK TO NEXT TRACK, TOWARDS TRACK 0
07EA 5A         POP     DX             ; RESTORE POINTER
07EB 52         PUSH    SI            ; SAVE POINTER
07EC 56         PUSH    SI            ; SAVE COUNTER
07ED E8 041C R  CALL    SEEK         ; SEEK TO TRACK
;
07F0 B8 04      MOV     AH,SENSE_DRV_ST ; SENSE DRIVE STATUS COMMAND BYTE
07F2 E8 082C R  CALL    SUP5         ; ISSUE THE COMMAND
07F5 E8 0580 R  CALL    RESULTS      ; GO GET STATUS
07F8 5E         POP     SI            ; RESTORE COUNTER
07F9 46         INC     SI            ; COUNT NUMBER OF SEEKS TIL AT HOME(TRACK 0)
;
07FA F6 06 0042 R 10  TEST   NEC_STATUS,HOME ; LOOK TO SEE IF HEAD IS AT TRACK 0
07FF 75 08      JNZ    SUP4          ; GO DETERMINE DRIVE TYPE
;
0801 83 FE 0B      CMP     SI,QUIET_SEEK+1 ; SEE IF THE NUMBER OF SEEKS = NUMBER ISSUED
0804 72 E2      JB     SUP3          ; IF LESS THAN, NOT DONE YET
;
0806 5B         POP     BX            ; RESTORE POINTER
0807 EB 10      JMP     SHORT NXT_DRV ; DRIVE NOT INSTALLED, BYPASS
;
0809 5B         SUP4:  POP     BX            ; RESTORE POINTER
080A 83 FE 0A      CMP     SI,QUIET_SEEK ; SEE IF SEEKS STEPPED EQUAL THE ORIGINAL
080D C6 87 0090 R 61  MOV     DSK_STATE[BX],POA_DUAL ; SETUP POWER ON ASSUMPTION
0812 73 05      JAE    NXT_DRV       ; IF YES 1.2 DRIVE
;
0814 C6 87 0090 R 93  MOV     DSK_STATE[BX],M3260326 ; ESTABLISH 320/360K STATE
0819 43         NXT_DRV: INC     BX            ; POINT TO NEXT DRIVE
081A 83 FB 02      CMP     BX,MAX_DRV    ; SEE IF DONE
081D 74 03      JE     SUP1          ; IF FINISHED LEAVE TEST
;
081F E9 07A0 R      JMP     SUP0         ; REPEAT TIL DONE FOR EACH DRIVE
;
0822 5D         SUP1:  POP     BP            ; RESTORE ALL REGISTERS
0823 1F         POP     DS            ; *
0824 07         POP     ES            ; *
0825 5F         POP     DI            ; *
0826 5E         POP     SI            ; *
0827 5A         POP     DX            ; *
0828 59         POP     CX            ; *
0829 5B         POP     BX            ; *
082A 5B         POP     AX            ; *
082B C3         RET                ; OTHERWISE RETURN
;----- KEEP STACK CORRECT FOR CALL TO NEC_OUTPUT IF ERROR
082C E8 03E2 R    SUP5:  CALL    NEC_OUTPUT    ; OUTPUT TO NEC
082F 8A E2      MOV     AH,DL         ; GET DRIVE NUMBER SELECTED
0831 E8 03E2 R    CALL    NEC_OUTPUT    ; OUTPUT TO NEC
0834 C3         RET
;
0835                                     DSKETTE_SETUP ENDP
;
0835                                     CODE     ENDS
                                         END

```



TITLE FIXED DISK BIOS FOR IBM DISK CONTROLLER 1-11-84

PUBLIC DISK_10
 PUBLIC HD_INT
 PUBLIC DISK_SETUP

EXTRN F1780:NEAR
 EXTRN F1781:NEAR
 EXTRN F1782:NEAR
 EXTRN F1790:NEAR
 EXTRN F1791:NEAR
 EXTRN FD_TBL:NEAR

```

-----INT 13-----
:
:  FIXED DISK I/O INTERFACE
:
:  THIS INTERFACE PROVIDES ACCESS TO 5 1/4" FIXED DISKS
:  THROUGH THE IBM FIXED DISK CONTROLLER.
:  THE BIOS ROUTINES ARE MEANT TO BE ACCESSED THROUGH
:  SOFTWARE INTERRUPTS ONLY. ANY ADDRESSES PRESENT IN
:  THE LISTINGS ARE INCLUDED ONLY FOR COMPLETENESS.
:  NOT FOR REFERENCE. APPLICATIONS WHICH REFERENCE
:  ABSOLUTE ADDRESSES WITHIN THE CODE SEGMENT
:  VIOLATE THE STRUCTURE AND DESIGN OF BIOS.
:
    
```

```

INPUT  (AH = HEX VALUE)

(AH)=00 RESET DISK (DL = 80H,81H) / DISKETTE
(AH)=01 READ THE STATUS OF THE LAST DISK OPERATION INTO (AL)
      NOTE: DL < 80H = DISKETTE
           DL > 80H = DISK

(AH)=02 READ THE DESIRED SECTORS INTO MEMORY
(AH)=03 WRITE THE DESIRED SECTORS FROM MEMORY
(AH)=04 VERIFY THE DESIRED SECTORS
(AH)=05 FORMAT THE DESIRED TRACK
(AH)=06 UNUSED
(AH)=07 UNUSED
(AH)=08 RETURN THE CURRENT DRIVE PARAMETERS
(AH)=09 INITIALIZE DRIVE PAIR CHARACTERISTICS
      INTERRUPT 41 POINTS TO DATA BLOCK FOR DRIVE 0
      INTERRUPT 46 POINTS TO DATA BLOCK FOR DRIVE 1

(AH)=0A READ LONG
(AH)=0B WRITE LONG
      NOTE: READ AND WRITE LONG ENCOMPASS 512 + 4 BYTES ECC
(AH)=0C SEEK
(AH)=0D ALTERNATE DISK RESET (SEE DL)
(AH)=0E UNUSED
(AH)=0F UNUSED
(AH)=10 TEST DRIVE READY
(AH)=11 RECALIBRATE
(AH)=12 UNUSED
(AH)=13 UNUSED
(AH)=14 CONTROLLER INTERNAL DIAGNOSTIC
(AH)=15 READ DASD TYPE
    
```

```

PAGE
:
:  REGISTERS USED FOR FIXED DISK OPERATIONS
:
:  (DL)  - DRIVE NUMBER (80H-81H FOR DISK, VALUE CHECKED)
:  (DH)  - HEAD NUMBER (0-15 ALLOWED, NOT VALUE CHECKED)
:  (CH)  - CYLINDER NUMBER (0-1023, NOT VALUE CHECKED)(SEE CL)
:  (CL)  - SECTOR NUMBER (1-17, NOT VALUE CHECKED)
:
:  NOTE: HIGH 2 BITS OF CYLINDER NUMBER ARE PLACED
:  IN THE HIGH 2 BITS OF THE CL REGISTER
:  (10 BITS TOTAL)
:  (AL)  - NUMBER OF SECTORS (MAXIMUM POSSIBLE RANGE 1-80H,
:  FOR READ/WRITE LONG 1-79H)
:  (ES:BX) - ADDRESS OF BUFFER FOR READS AND WRITES,
:  (NOT REQUIRED FOR VERIFY)
:
:  FORMAT (AH=5) ES:BX POINTS TO A 512 BYTE BUFFER. THE FIRST
:  2*(SECTORS/TRACK) BYTES CONTAIN F,N FOR EACH SECTOR.
:  F = 00H FOR A GOOD SECTOR
:  N = SECTOR NUMBER
:  FOR AN INTERLEAVE OF 2 AND 17 SECTORS/TRACK
:  THE TABLE SHOULD BE:
:
:  DB 00H,01H,00H,0AH,00H,02H,00H,0BH,00H,03H,00H,0CH
:  DB 00H,04H,00H,0DH,00H,05H,00H,0EH,00H,06H,00H,0FH
:  DB 00H,07H,00H,10H,00H,08H,00H,11H,00H,09H
    
```

```

OUTPUT
:
:  AH = STATUS OF CURRENT OPERATION
:  STATUS BITS ARE DEFINED IN THE EQUATES BELOW
:  CY = 0 SUCCESSFUL OPERATION (AH=0 ON RETURN)
:  CY = 1 FAILED OPERATION (AH HAS ERROR REASON)
:
:  NOTE: ERROR 11H INDICATES THAT THE DATA READ HAD A RECOVERABLE
:  ERROR WHICH WAS CORRECTED BY THE ECC ALGORITHM. THE DATA IS
:  PROBABLY GOOD, HOWEVER THE BIOS ROUTINE INDICATES AN
:  ERROR TO ALLOW THE CONTROLLING PROGRAM A CHANCE TO DECIDE
:  FOR ITSELF. THE ERROR MAY NOT RECUR IF THE DATA IS
:  REWRITTEN.
:
:  IF DRIVE PARAMETERS WERE REQUESTED,
:
:  DL = NUMBER OF CONSECUTIVE ACKNOWLEDGING DRIVES ATTACHED (0-2)
:  (CONTROLLER CARD ZERO TALLY ONLY)
:  DH = MAXIMUM USEABLE VALUE FOR HEAD NUMBER
:  CH = MAXIMUM USEABLE VALUE FOR CYLINDER NUMBER
:  CL = MAXIMUM USEABLE VALUE FOR SECTOR NUMBER
:  AND CYLINDER NUMBER HIGH BITS
:
:  IF READ DASD TYPE WAS REQUESTED,
:
:  AH = 0 - NOT PRESENT
:  1 - DISKETTE - NO CHANGE LINE AVAILABLE
:  2 - DISKETTE - CHANGE LINE AVAILABLE
:  3 - FIXED DISK
:  CX,DX = NUMBER OF 512 BYTE BLOCKS WHEN AH = 3
:
:  REGISTERS WILL BE PRESERVED EXCEPT WHEN THEY ARE USED TO RETURN
:  INFORMATION.
:
:  NOTE: IF AN ERROR IS REPORTED BY THE DISK CODE, THE APPROPRIATE
:  ACTION IS TO RESET THE DISK, THEN RETRY THE OPERATION.
    
```

```

= 00FF EQU 0FFH ; NOT IMPLEMENTED
= 00C0 EQU 0C0H ; STATUS ERROR/ERROR REG=0
= 00CC EQU 0CCH ; WRITE FAULT ON SELECTED DRIVE
= 00BB EQU 0BBH ; UNDEFINED ERROR OCCURRED
= 00AA EQU 0AAH ; DRIVE NOT READY
= 0080 EQU 80H ; ATTACHMENT FAILED TO RESPOND
= 0040 EQU 40H ; SEEK OPERATION FAILED
:
SENSE_FAIL EQU 0FFH ; NOT IMPLEMENTED
NO_ERR EQU 0C0H ; STATUS ERROR/ERROR REG=0
WRITE_FAULT EQU 0CCH ; WRITE FAULT ON SELECTED DRIVE
UNDEF_ERR EQU 0BBH ; UNDEFINED ERROR OCCURRED
NOT_RDY EQU 0AAH ; DRIVE NOT READY
TIME_OUT EQU 80H ; ATTACHMENT FAILED TO RESPOND
BAD_SEEK EQU 40H ; SEEK OPERATION FAILED
    
```

SECTION 5

```

= 0020 BAD_CNTRL EQU 20H ; CONTROLLER HAS FAILED
= 0011 DATA_CORRECTED EQU 11H ; ECC CORRECTED DATA ERROR
= 0010 BAD_ECC EQU 10H ; BAD ECC ON DISK READ
= 000B BAD_TRACK EQU 0BH ; NOT IMPLEMENTED
= 000A BAD_SECTOR EQU 0AH ; BAD SECTOR FLAG DETECTED
= 0009 DMA_BOUNDARY EQU 09H ; DATA EXTENDS TOO FAR
= 0007 INIT_FAIL EQU 07H ; DRIVE PARAMETER ACTIVITY FAILED
= 0005 BAD_RESET EQU 05H ; RESET FAILED
= 0004 REGRD_NOT_FND EQU 04H ; REQUESTED SECTOR NOT FOUND
= 0002 BAD_ADDR_MARK EQU 02H ; ADDRESS MARK NOT FOUND
= 0001 BAD_CMD EQU 01H ; BAD COMMAND PASSED TO DISK I/O
PAGE

```

```

-----
; FIXED DISK PARAMETER TABLE
;
; - THE TABLE IS COMPOSED OF A BLOCK DEFINED AS:
;
; +0 (1 WORD) - MAXIMUM NUMBER OF CYLINDERS
; +2 (1 BYTE) - MAXIMUM NUMBER OF HEADS
; +3 (1 WORD) - NOT USED/SEE PC-XT
; +5 (1 WORD) - STARTING WRITE PRECOMPENSATION CYL
; +7 (1 BYTE) - MAXIMUM ECC DATA BURST LENGTH
; +8 (1 BYTE) - CONTROL BYTE
; BIT 7 DISABLE RETRIES -OR-
; BIT 6 DISABLE RETRIES
; BIT 3 MORE THAN 8 HEADS
; +9 (3 BYTES) - NOT USED/SEE PC-XT
; +12 (1 WORD) - LANDING ZONE
; +14 (1 BYTE) - NUMBER OF SECTORS/TRACK
; +15 (1 BYTE) - RESERVED FOR FUTURE USE
;
; - TO DYNAMICALLY DEFINE A SET OF PARAMETERS
; BUILD A TABLE FOR UP TO 15 TYPES AND PLACE
; THE CORRESPONDING VECTOR INTO INTERRUPT 41
; FOR DRIVE 0 AND INTERRUPT 46 FOR DRIVE 1.
;
-----

```

```

.LIST
PAGE
C INCLUDE SEGMENT_SRC
C CODE SEGMENT BYTE PUBLIC
0000
C

```

```

-----
; HARDWARE SPECIFIC VALUES
;
; - CONTROLLER I/O PORT
; > WHEN READ FROM:
; HF_PORT+0 READ DATA (FROM CONTROLLER TO CPU)
; HF_PORT+1 GET ERROR REGISTER
; HF_PORT+2 GET SECTOR COUNT
; HF_PORT+3 GET SECTOR NUMBER
; HF_PORT+4 GET CYLINDER LOW
; HF_PORT+5 GET CYLINDER HIGH (2 BITS)
; HF_PORT+6 GET SIZE/DRIVE/HEAD
; HF_PORT+7 GET STATUS REGISTER
; > WHEN WRITTEN TO:
; HF_PORT+0 WRITE DATA (FROM CPU TO CONTROLLER)
; HF_PORT+1 SET PRECOMPENSATION CYLINDER
; HF_PORT+2 SET SECTOR COUNT
; HF_PORT+3 SET SECTOR NUMBER
; HF_PORT+4 SET CYLINDER LOW
; HF_PORT+5 SET CYLINDER HIGH (2 BITS)
; HF_PORT+6 SET SIZE/DRIVE/HEAD
; HF_PORT+7 SET COMMAND REGISTER
;
-----

```

```

= 01F0 HF_PORT EQU 01F0H ; DISK PORT
= 03F6 HF_REG_PORT EQU 3F6H

; STATUS REGISTER
= 0001 ST_ERROR EQU 00000001B ;
= 0002 ST_INDEX EQU 00000010B ;
= 0004 ST_CORRCTD EQU 00000100B ; ECC CORRECTION SUCCESSFUL
= 0008 ST_DRQ EQU 00001000B ;
= 0010 ST_SEEK_CMPL EQU 00010000B ; SEEK COMPLETE
= 0020 ST_WRT_FLT EQU 00100000B ; WRITE FAULT
= 0040 ST_READY EQU 01000000B ;
= 0080 ST_BUSY EQU 10000000B ;

; ERROR REGISTER
= 0001 ERR_DAM EQU 00000001B ; DATA ADDRESS MARK NOT FOUND
= 0002 ERR_TRK_0 EQU 00000010B ; TRACK 0 NOT FOUND ON RECAL
= 0004 ERR_ABORT EQU 00000100B ; ABORTED COMMAND
; ERR_ID EQU 00001000B ; NOT USED
= 0010 ERR_ID EQU 00010000B ; ID NOT FOUND
; ERR_ID EQU 00100000B ; NOT USED
= 0040 ERR_DATA_ECC EQU 01000000B ;
= 0080 ERR_BAD_BLOCK EQU 10000000B ;

= 0010 RECAL_CMD EQU 00010000B ; DRIVE RECAL (10H)
= 0020 READ_CMD EQU 00100000B ; READ (20H)
= 0030 WRITE_CMD EQU 00100000B ; WRITE (30H)
= 0040 VERIFY_CMD EQU 01000000B ; VERIFY (40H)
= 0050 FMTTRK_CMD EQU 01010000B ; FORMT TRACK (50H)
= 0060 INIT_CMD EQU 01100000B ; INITIALIZE (60H)
= 0070 SEEK_CMD EQU 01100000B ; SEEK (70H)
= 0090 DIAG_CMD EQU 10010000B ; DIAGNOSTIC (90H)
= 0091 SET_PARM_CMD EQU 10010001B ; DRIVE PARMS (91H)
= 0001 NO_RETRIES EQU 00000001B ; CMD MODIFIER (01H)
= 0002 ECC_MODE EQU 00000010B ; CMD MODIFIER (02H)
= 0008 BUFFER_MODE EQU 00001000B ; CMD MODIFIER (08H)

= 0040 INT_CTL_PORT EQU 0A0H ; 8259 CONTROL PORT #2
= 0020 INT1_CTL_PORT EQU 020H ; 8259 CONTROL PORT #1
= 0020 EO1 EQU 20H ; END OF INTERRUPT COMMAND

= 0002 MAX_FILE EQU 2
= 0002 S_MAX_FILE EQU 2

= 0020 DELAY_1 EQU 20H ; DELAY FOR OP COMPLETE
= 0600 DELAY_2 EQU 0600H ; DELAY FOR READY
= 0100 DELAY_3 EQU 0100H ; DELAY FOR DATA REQUEST

= 0008 HF_FAIL EQU 08H ; CMOS FLAG IN BYTE 0EH
; TO INHIBIT DISK IPL
EXTRN P_MSG:NEAR
ASSUME CS:CODE

```

```

PAGE
-----
; FIXED DISK I/O SETUP
;

```

```

; - ESTABLISH TRANSFER VECTORS FOR THE FIXED DISK
; - PERFORM POWER ON DIAGNOSTICS
; SHOULD AN ERROR OCCUR A "1701" MESSAGE IS DISPLAYED
;
;-----

```

```

0000          DISK_SETUP  PROC  NEAR
0000          ASSUME  ES:ABS0
0002          SUB     AX,AX          ; ZERO
0004          MOV     ES,AX
0005          CL     I
0005          MOV     AX,WORD PTR ORG_VECTOR          ; GET DISKETTE VECTOR
0009          MOV     WORD PTR DISK_VECTOR,AX        ; INTO INT 40H
000D          MOV     AX,WORD PTR ORG_VECTOR+2
0011          MOV     WORD PTR DISK_VECTOR+2,AX
0015          MOV     WORD PTR ORG_VECTOR, OFFSET DISK_IO  ; HDISK HANDLER
001C          MOV     WORD PTR ORG_VECTOR+2,CS
0021          MOV     AX, OFFSET HD_INT              ; HDISK INTERRUPT
0024          MOV     WORD PTR HDISK_INT,AX
0028          MOV     WORD PTR HDISK_INT+2,CS
002D          MOV     WORD PTR HF_TBL_VEC,OFFSET FD_TBL  ; PARM TBL DRV 80
0034          MOV     WORD PTR HF_TBL_VEC+2,CS
0039          MOV     WORD PTR HF1_TBL_VEC,OFFSET FD_TBL  ; PARM TBL DRV 81
0040          MOV     WORD PTR HF1_TBL_VEC+2,CS
0045          ST     I
0046          IN     AL,INT_CTL_PORT+1          ; ** IO DELAY NOT REQUIRED **
0048          AND     AL,0BFH                  ; TURN ON SECOND INTERRUPT CHIP
004A          OUT    AL,INT_CTL_PORT+1,AL
004C          IN     AL,INT_CTL_PORT+1
004E          AND     AL,0FBH                  ; LET INTERRUPTS PASS THRU TO
0050          OUT    INT1_CTL_PORT+1,AL        ; SECOND CHIP

          ASSUME  DS:DATA
0052          MOV     AX,DATA          ; ESTABLISH SEGMENT
0055          MOV     DS,AX
0057          MOV     DI,SK_STATUS1,0    ; RESET THE STATUS INDICATOR
005C          MOV     HF_NUM,0          ; ZERO NUMBER OF HARD FILES
0061          MOV     CONTROL_BYTE,0
0066          MOV     AL,8EH
0068          OUT    70H,AL              ; CHECK CMOS VALIDITY
006A          JMP     SHORT $+2
006C          IN     AL,71H
006E          MOV     AH,AL
0070          AND     AL,0COH            ; SAVE CMOS FLAG
0072          JNZ     POD_DONE
0074          AND     AH,NOT HF_FAIL     ; CMOS NOT VALID -- NO HARD FILES
0077          MOV     AL,8EH
0079          OUT    70H,AL              ; WRITE IT BACK
007B          MOV     AL,AH
007D          JMP     SHORT $+2
007F          OUT    71H,AL
0081          MOV     AL,92H
0083          OUT    70H,AL              ; ACCESS HARD FILE BYTE IN CMOS
0085          JMP     SHORT $+2
0087          IN     AL,71H
0089          MOV     PORT_OFF,0        ; ZERO CARD OFFSET
008E          MOV     BL,AL              ; SAVE HARD FILE BYTE
0090          MOV     AH,0
0092          AND     AL,0F0H            ; GET FIRST DRIVE TYPE
0094          JZ     POD_DONE           ; NO HARD FILES
0096          ADD     AX,OFFSET FD_TBL-16D ; COMPUTE OFFSET
0099          MOV     WORD PTR HF_TBL_VEC,AX
009D          MOV     HF_NUM,1          ; AT LEAST ONE DRIVE
00A2          MOV     AL,BL
00A4          ISHL   LABEL,AL           ; GET SECOND DRIVE TYPE
          LABEL  BYTE
00A4          SHL   AL,1
00A6          LABEL BYTE
00A4          ORG   OFFSET CS:??0000
00A4          ORG   DB
00A6          ORG   OFFSET CS:??0001
00A8          ORG   DB
00A7          JZ     SHORT L4            ; ONLY ONE DRIVE
00A9          MOV     AH,0
00AB          ADD     AX,OFFSET FD_TBL-16D ; COMPUTE OFFSET FOR DRIVE 1
00AE          MOV     WORD PTR HF1_TBL_VEC,AX
00B2          MOV     HF_NUM,2          ; TWO DRIVES
00B7          MOV     DL,80H
00B9          MOV     AH,14H
00BB          INT    13H
00BD          JC     CTL_ERRX          ; CHECK THE CONTROLLER
00BF          MOV     AX,TIMER_LOW
00C2          MOV     BX,AX              ; GET START TIMER COUNTS
00C4          ADD     AX,6*182          ; 60 SECONDS * 18.2
00C7          MOV     CX,AX
00C9          CALL   HD_RESET_1         ; SET UP DRIVE 0
00CC          CMP     HF_NUM,1         ; WERE THERE TWO DRIVES?
00D1          JBE    POD_DONE          ; NO-ALL DONE
00D3          MOV     DL,81H
00D5          CALL   HD_RESET_1         ; SET UP DRIVE 1
          POD_DONE:
00D8          CL     I
00D9          IN     AL,021H            ; ** IO DELAY NOT REQUIRED **
00DB          AND     AL,0FEH          ; BE SURE TIMER IS ENABLED
00DD          OUT    021H,AL
00DF          ST     I
00E0          RET

;---- POD ERROR

00E1          CTL_ERRX:
00E1          MOV     SI,OFFSET F1782    ; CONTROLLER ERROR
00E4          CALL   SET_FAIL           ; DONT IPL FROM DISK
00E7          CALL   P_MSG              ; DISPLAY ERROR
00EA          MOV     BP,0FH            ; POD ERROR FLAG
00ED          JMP     SHORT POD_DONE

          HD_RESET  PROC  NEAR
00EF          PUSH  BX                  ; SAVE TIMER LIMITS
00F0          PUSH  CX
00F1          MOV     AH,09H            ; SET DRIVE PARMS
00F3          INT    13H
00F5          JC     RES_2
00F7          MOV     AH,11H
00F9          INT    13H
00FB          JNC   RES_OK             ; RECALIBRATE DRIVE
00FD          CALL   RES_CHK           ; DRIVE OK
00FE          JNC   RES_OK             ; CHECK TIME OUT
0100          CALL   RES_1
0102          JNC   RES_1
0105          MOV     SI,OFFSET F1781    ; INDICATE DISK 1 FAILURE
0108          DL    1
010A          TEST  RES_E1
010B          JNZ   RES_E1
010D          MOV     SI,OFFSET F1780    ; INDICATE DISK 0 FAILURE
010E          CALL   SET_FAIL           ; DONT TRY TO IPL DISK 0
0110          JMP   SHORT RES_E1
0112          MOV     RES_CHK,MOV       AH,08H          ; GET MAX CYL,HEAD,SECTOR

```

```

0114 8A DA      MOV     BL,DL      ; SAVE DRIVE CODE
0116 CD 13     INT     13H
0118 72 33     JC      RES_ER
011A 8A 03     DL     DL,BL
011C 88 0401    MOV     RES_3,AX,0401H ; RESTORE DRIVE CODE
011E CD 13     INT     13H ; VERIFY THE LAST SECTOR
0121 73 3B     JNC     RES_OK     ; VERIFY OK
0123 80 FC 0A   CMP     AH,BAD_SECTOR ; OK ALSO IF JUST ID READ
0126 74 36     JE      RES_OK
0128 80 FC 11   CMP     AH,DATA_CORRECTED
012B 74 31     JE      RES_OK
012D 80 FC 10   CMP     AH,BAD_ECC
0130 74 2C     JE      RES_OK
0132 E8 0178 R  JC     CALL        ; CHECK FOR TIME OUT
0135 72 16     JC     RES_ER     ; FAILED
0137 A0 0044 R  MOV     AL,CMD_BLOCK+2 ; GET SECTOR ADDRESS
013A FE C8     DEC     AL        ; TRY PREVIOUS ONE
013C 74 D4     JZ      RES_OK     ; WE'VE TRIED ALL SECTORS ON TRACK
013E 8A 2E 0045 R MOV     CH,CMD_BLOCK+3 ; GET CYLINDER
0142 8A 0E 0046 R MOV     CL,CMD_BLOCK+4 ; NUMBER
0146           + ??0003 LABEL BYTE ; MOVE THE BITS UP
0146 DO E1     + SHL     CL,1
0148           + ??0004 LABEL BYTE
0146           + ORG     OFFSET CS:??0003
0146 CO         + DB
0148           + ORG     OFFSET CS:??0004
0148 06         + DB
0149 0A C8     OR      CL,AL     ; PUT SECTOR NUMBER IN PLACE
014B EB 1F     JMP     RES_3     ; TRY AGAIN
014D BE 0000 E  MOV     RES_ER,MOV,S1,OFFSET F1791 ; INDICATE DISK 1 ERROR
0150 F6 C2 01   TEST   DL,1
0153 75 03     JNZ     RES_E1
0155 BE 0000 E  MOV     RES_E1,MOV,S1,OFFSET F1790 ; INDICATE DISK 0 ERROR
0158 E8 0000 E  RES_ER1: CALL    P_MSG
015B BD 000F   MOV     RES_OK,MOV,BP,OFH
015E 59        RES_OK: POP     CX ; RESTORE TIMER LIMITS
015F 5B       POP     BX
0160 C3       RET
0161        HD_RESET_1 ENDP

0161        SET_FAIL PROC NEAR
0161 80 8E     MOV     AL,8EH ; GET CMOS ERROR BYTE
0163 E6 70     OUT    70H,AL
0165 EB 00     JMP     SHORT S+2
0167 E4 71     IN     AL,71H
0169 0C 08     OR     AL,HF_FAIL ; SET DONT IPL FROM DISK FLAG
016B 8A E0     MOV     AH,SAV_IT ; SAVE IT
016D 80 8E     MOV     AL,8EH ; CMOS BYTE ADDRESS
016F E6 70     OUT    70H,AL
0171 8A C4     MOV     AH,SAV_IT
0173 EB 00     JMP     SHORT S+2
0175 E6 71     OUT    71H,AL ; PUT IT OUT
0177 C3       RET
0178        SET_FAIL ENDP

0178        POD_TCHK PROC NEAR
0178 58       POP     AX ; CHECK FOR 30 SECOND TIME OUT
0179 59       POP     CX ; SAVE RETURN
017A 5B       POP     BX ; GET TIME OUT LIMITS
017B 53       PUSH    BX ; AND SAVE THEM AGAIN
017C 51       PUSH    CX
017D 50       PUSH    AX ; RESTORE RETURN
017E A1 006C R MOV     AX,TIMER_LOW ; AX = CURRENT TIME
; BX = START TIME
; CX = END TIME

0181 3B D9     CMP     BX,CX
0183 72 06     JB      TCHK1 ; START < END
0185 3B D8     CMP     BX,AX
0187 72 0C     JB      TCHKG ; END < START < CURRENT
0189 EB 04     JMP     SHORT TCHK2 ; END, CURRENT < START
018B 3B C3     CMP     AX,BX ; CURRENT < START < END
018D 72 04     JB      TCHKG
018F 3B C1     CMP     AX,CX ; START < CURRENT < END
0191 72 02     JB      TCHKG ; OR CURRENT < END < START
; CARRY SET INDICATES TIME OUT

0193 F9       STC ; CARRY SET
0194 C3       RET ; CARRY SET INDICATES TIME OUT
0195 F8       TCHKG: CLC
0196 C3       RET ; INDICATE STILL TIME
0197        POD_TCHK ENDP

0197        DISK_SETUP ENDP
PAGE
;-----
;----- FIXED DISK BIOS ENTRY POINT :-----
;-----

0197        DISK_IO PROC FAR
ASSUME DS:NOTHING,ES:NOTHING
0197 80 FA 80   CMP     DL,80H ; TEST FOR FIXED DISK DRIVE
019A 73 05     JAE     HARD_DISK ; YES, HANDLE HERE
019C CD 40     INT     40H ; DISKETTE HANDLER
019E         RET     2 ; BACK TO CALLER
019E CA 0002   HARD_DISK: RET
01A1        ASSUME DS:DATA
01A1 FB       STI ; ENABLE INTERRUPTS
01A2 0A E4     OR     AH,AH
01A4 75 09     JNZ    A2 ; RESET NEC WHEN AH=0
01A6 CD 40     INT     40H
01A8 2A E4     SUB     AH,AH
01AA 80 FA 81   CMP     DL,(80H + S_MAX_FILE - 1)
01AD 77 EF     JA     RET_2
01AF        A2:
01AF 80 FC 08   CMP     AH,08H ; GET PARAMETERS IS A SPECIAL CASE
01B2 75 03     JNZ    A3
01B4 E9 038B R JMP     GET_PARM_N
01B7 80 FC 15   CMP     AH,15H ; READ DASD TYPE IS ALSO
01BA 75 03     JNZ    A4
01BC E9 0349 R JMP     READ_DASD_TYPE
01BF        A4:
01BF 53       PUSH    BX ; SAVE REGISTERS DURING OPERATION
01C0 51       PUSH    CX
01C1 52       PUSH    DX
01C2 51       PUSH    DS
01C3 06       PUSH    ES
01C4 56       PUSH    SI
01C5 57       PUSH    DI
01C6 0A E4     OR     AH,AH ; CHECK FOR RESET
01C8 75 02     JNZ    A5
01CA B2 80     MOV     DL,80H ; FORCE DRIVE 80 FOR RESET
01CC E8 0212 R CALL    DISK_IO_CONT ; PERFORM THE OPERATION
01CF 50       PUSH    AX
01D0 B8 ----- R MOV     AX,DATA
01D3 8E D8     MOV     DS,AX ; ESTABLISH SEGMENT

```



```

01D5 58 POP AX
01D6 8A 26 0074 R MOV AH,DISK_STATUS1 ; GET STATUS FROM OPERATION
01DA 80 FC 01 CMP AH,1 ; SET THE CARRY FLAG TO INDICATE
01DD F5 CMC ; SUCCESS OR FAILURE
01DE 5F POP DI ; RESTORE REGISTERS
01DF 5E POP SI
01E0 07 POP ES
01E1 1F POP DS
01E2 5A POP DX
01E3 59 POP CX
01E4 5B POP BX
01E5 CA 0002 RET 2 ; THROW AWAY SAVED FLAGS
01E8 DISK_IO ENDP

M1 LABEL WORD ; FUNCTION TRANSFER TABLE
01E8 02B3 R DW DISK_RESET ; 000H
01EA 0307 R DW RETURN_STATUS ; 001H
01EC 0310 R DW DISK_READ ; 002H
01EE 0318 R DW DISK_WRITE ; 003H
01F0 0320 R DW DISK_VERIFY ; 004H
01F2 0333 R DW FMT_TRK ; 005H
01F4 02AB R DW BAD_COMMAND ; 006H FORMAT BAD SECTORS
01F6 02AB R DW BAD_COMMAND ; 007H FORMAT DRIVE
01F8 02AB R DW BAD_COMMAND ; 008H RETURN PARMS
01FA 03EA R DW INIT_DRV ; 009H
01FC 041F R DW RD_LONG ; 00AH
01FE 0427 R DW WR_LONG ; 00BH
0200 042F R DW DISK_SEEK ; 00CH
0202 02B3 R DW DISK_RESET ; 00DH
0204 02AB R DW BAD_COMMAND ; 00EH READ BUFFER
0206 02AB R DW BAD_COMMAND ; 00FH WRITE BUFFER
0208 044E R DW TST_RDY ; 010H
020A 0469 R DW HDISK_RECAL ; 011H
020C 02AB R DW BAD_COMMAND ; 012H RAM DIAGNOSTIC
020E 02AB R DW BAD_COMMAND ; 013H DRIVE DIAGNOSTIC
0210 0489 R DW CTRLR_DIAGNOSTIC ; 014H CONTROLLER DIAGNOSTIC
= 002A MTL EQU S-M1

DISK_IO_CORT PROC NEAR
0212 50 PUSH AX
0213 88 ---- R MOV AX,DATA
0216 8E DB MOV DS,AX ; ESTABLISH SEGMENT
0218 58 POP AX
0219 80 FC 01 CMP AH,01H ; RETURN STATUS
021C 75 03 JNZ SU0
021E E9 0307 R JMP RETURN_STATUS
0221 SU0:
0221 C6 06 0074 R 00 MOV DISK_STATUS1,0 ; RESET THE STATUS INDICATOR
0226 53 PUSH BX ; SAVE DATA ADDRESS
0227 8A 1E 0075 R MOV BL,HF_NUM ; GET NUMBER OF DRIVES
0229 50 PUSH AX
022C 80 E2 7F AND DL,7FH ; GET DRIVE AS 0 OR 1
022F 3A DA CMP BL,DL
0231 76 76 JBE BAD_COMMAND_POP ; INVALID DRIVE
0233 06 PUSH ES
0234 E8 0684 R CALL GET_VEC ; GET DISK PARMS
0237 26: 88 47 05 MOV AX,WORD PTR ES:[BX][5] ; GET WRITE PRE-COMP CYL

023B + ????006 LABEL BYTE
023B D1 E8 SHR AX,1
023B + ????007 LABEL BYTE
023B + ????008 ORG OFFSET CS:????006 LABEL NEAR
023B C1 + ????008 LABEL NEAR
023B + ????008 DB 0C1H
023D + ????008 ORG OFFSET CS:????007
023D 02 DB 2
023E A2 0042 R MOV CMD_BLOCK,AL
0241 26: 8A 47 08 MOV AL,BYTE PTR ES:[BX][8] ; GET CONTROL BYTE MODIFIER
0245 52 PUSH DX
0246 8A 03F6 MOV DX,HF_REG_PORT
0249 EE OUT DX,AL ; SET EXTRA HEAD OPTION
024A 5A POP DX
024B 07 POP ES
024C 8A 26 0076 R MOV AH,CONTROL_BYTE ; SET EXTRA HEAD OPTION IN
0250 80 E4 C0 AND AH,0C0H ; CONTROL BYTE
0253 0A E0 AH,0R
0255 88 26 0076 R MOV CONTROL_BYTE,AH
0259 58 POP AX
025A A2 0043 R MOV CMD_BLOCK+1,AL ; SECTOR COUNT
025D 50 PUSH AX
025E 8A C1 MOV AL,CL ; GET SECTOR NUMBER
0260 24 3F AND AL,3FH
0262 A2 0044 R MOV CMD_BLOCK+2,AL
0265 88 2E 0045 R MOV CMD_BLOCK+3,CH ; GET CYLINDER NUMBER
0269 8A C1 MOV AL,CL

026B + ????009 LABEL BYTE
026B D0 E8 SHR AL,1
026D + ????00A LABEL BYTE
026B + ????00A ORG OFFSET CS:????009
026B + ????00A DB 0C0H
026D + ????00A ORG OFFSET CS:????00A
026D 06 DB 6
026E A2 0046 R MOV CMD_BLOCK+4,AL ; CYLINDER HIGH ORDER 2 BITS
0271 8A C2 MOV AL,DL ; DRIVE NUMBER

0273 + ????00C LABEL BYTE
0273 D0 E0 SHL AL,1
0275 + ????00D LABEL BYTE
0273 + ????00D ORG OFFSET CS:????00C
0273 + ????00D DB 0C0H
0275 + ????00D ORG OFFSET CS:????00D
0275 04 DB 4
0276 80 E6 0F AND DH,0FH ; HEAD NUMBER
0279 0A C6 OR AL,DH
027B 0C A0 OR AL,80H OR 20H ; ECC AND 512 BYTE SECTORS
027D A2 0047 R MOV CMD_BLOCK+5,AL ; ECC/SIZE/DRIVE/HEAD
0280 58 POP AX
0281 50 PUSH AX
0282 8A C4 MOV AL,AH ; GET INTO LOW BYTE
0284 32 E4 XOR AH,AH ; ZERO HIGH BYTE
0286 D1 E0 SAL AX,1 ; *2 FOR TABLE LOOKUP
0288 8B F0 MOV SI,AX ; PUT INTO SI FOR BRANCH
028A 3D 002A CMP AX,H1L ; TEST WITHIN RANGE
028D 73 1A JNB BAD_COMMAND_POP
028F 58 POP AX ; RESTORE AX
0290 5B POP BX ; AND DATA ADDRESS
0291 51 PUSH CX
0292 50 PUSH AX ; ADJUST ES:BX
0293 8B CB MOV CX,BX ; GET 3 HIGH ORDER NYBBLES OF BX

0295 + ????00F LABEL BYTE
0295 D1 E9 SHR CX,1
0297 + ????010 LABEL BYTE
0295 + ????010 ORG OFFSET CS:????00F
0299 + ????011 LABEL NEAR

```

```

0295 C1 + DB OC1H
0297 + ORG OFFSET CS:770010
0297 04 + DB 4
0298 8C C0 MOV AX,ES
029A 03 C1 ADD AX,CX
029C 8E C0 MOV ES,AX
029E 81 E3 000F AND BX,000FH ; ES:BX CHANGED TO ES:000H
02A2 58 POP AX
02A3 59 POP CX
02A4 2E: FF A4 01E8 R JMP WORD PTR CS:[SI + OFFSET M1]
02A9 BAD_COMMAND_POP:
02A9 58 POP AX
02AA 5B POP BX
02AB BAD_COMMAND:
02AB C6 06 0074 R 01 MOV DISK_STATUS1,BAD_CMD ; COMMAND ERROR
02AB 80 00 MOV AL,0
02B2 C3 RET
02B3 DISK_IO_CONT ENDP

;-----
; RESET THE DISK SYSTEM (AH = 000H)
;-----

02B3 DISK_RESET PROC NEAR
02B3 FA CL I ; ** IO DELAY NOT REQUIRED **
02B4 E4 A1 IN AL,INT_CTL_PORT+1 ; GET THE MASK REG
02B6 24 8F AND AL,0BFH ; ENABLE HARD FILE INT.
02B8 E6 A1 OUT INT_CTL_PORT+1,AL
02BA FB STI ; START INTERRUPTS
02BB 80 04 MOV AL,04H
02BD BA 03F6 MOV DX,HF_REG_PORT
02C0 EE OUT DX,AL ; RESET
02C1 B9 000A MOV CX,10 ; DELAY COUNT
02C4 49 DRD: DEC CX
02C5 75 FD JNZ DRD ; WAIT 4.8 MICRO-SEC
02C7 A0 0076 R MOV AL,CONTROL_BYTE
02CA 24 0F AND AL,0FH ; SET HEAD OPTION
02CC EE OUT DX,AL ; TURN RESET OFF
02CD E8 05DF R CALL NOT_BUSY
02D0 75 2F JNZ DRERR ; TIME OUT ON RESET
02D2 BA 01F1 MOV DX,HF_PORT+1
02D5 EC IN AL,DX ; GET RESET STATUS
02D6 3C 01 CMP AL,1
02D8 75 27 JNZ DRERR ; BAD RESET STATUS
02DA 80 26 0047 R EF AND CMD_BLOCK+5,0EFH ; SET TO DRIVE 0
02DF 2A D2 SUB DL,DL
02E1 E8 03EA R CALL INIT_DRV ; SET MAX HEADS
02E4 E8 0465 R CALL HDISK_RECAL ; RECAL TO RESET SEEK SPEED
02E7 E8 0E 0075 R 01 CMP HF_NUM,1 ; CHECK FOR DRIVE 1
02EC 76 0D JBE DRE
02EE 80 0E 0047 R 10 OR CMD_BLOCK+5,010H ; SET TO DRIVE 1
02F3 B2 01 MOV DL,1
02F5 E8 03EA R CALL INIT_DRV ; SET MAX HEADS
02F8 E8 0465 R CALL HDISK_RECAL ; RECAL TO RESET SEEK SPEED
02FB C6 06 0074 R 00 DRE: MOV DISK_STATUS1,0 ; IGNORE ANY SET UP ERRORS
0300 C3 RET
0301 C6 06 0074 R 05 DRERR: MOV DISK_STATUS1,BAD_RESET ; CARD FAILED
0306 C3 RET
0307 DISK_RESET ENDP

;-----
; DISK STATUS ROUTINE (AH = 001H)
;-----

0307 RETURN_STATUS PROC NEAR
0307 A0 0074 R MOV AL,DISK_STATUS1 ; OBTAIN PREVIOUS STATUS
030A C6 06 0074 R 00 MOV DISK_STATUS1,0 ; RESET STATUS
030F C3 RET
0310 RETURN_STATUS ENDP

;-----
; DISK READ ROUTINE (AH = 002H)
;-----

0310 DISK_READ PROC NEAR
0310 C6 06 0048 R 20 MOV CMD_BLOCK+6,READ_CMD
0315 E9 04BB R JMP COMMAND_I
0318 DISK_READ ENDP

;-----
; DISK WRITE ROUTINE (AH = 003H)
;-----

0318 DISK_WRITE PROC NEAR
0318 C6 06 0048 R 30 MOV CMD_BLOCK+6,WRITE_CMD
031D E9 04FB R JMP COMMAND_O
0320 DISK_WRITE ENDP

;-----
; DISK VERIFY (AH = 004H)
;-----

0320 DISK_VERF PROC NEAR
0320 C6 06 0048 R 40 MOV CMD_BLOCK+6,VERIFY_CMD
0325 E8 0544 R CALL COMMAND
0328 75 08 JNZ VERF_EXIT ; CONTROLLER STILL BUSY
032A E8 05A5 R CALL WAIT
032D 75 03 JNZ VERF_EXIT ; TIME OUT
032F E8 061E R CALL CHECK_STATUS
0332 VERF_EXIT:
0332 C3 RET
0333 DISK_VERF ENDP

;-----
; FORMATTING (AH = 005H)
;-----

0333 FMT_TRK PROC NEAR
0333 C6 06 0048 R 50 MOV CMD_BLOCK+6,FMTTRK_CMD ; FORMAT TRACK (AH = 005H)
0338 06 PUSH ES
0339 53 PUSH BX
033A E8 06B4 R CALL GET_VEC ; GET DISK PARMS ADDRESS
033D 26: 8A 47 0E MOV AL,ES:[BX][14] ; GET SECTORS/TRACK
0341 A2 0043 R MOV CMD_BLOCK+1,AL ; SET SECTOR COUNT IN COMMAND
0344 5B POP BX
0345 07 POP ES
0346 E9 050D R JMP CMD_OF ; GO EXECUTE THE COMMAND
0349 FMT_TRK ENDP
PAGE

;-----
; READ DASD TYPE (AH = 15H)
;-----

0349 READ_DASD_TYPE LABEL NEAR
0349 READ_D_T PROC FAR ; GET DRIVE PARAMETERS
0349 1E PUSH DS ; SAVE REGISTERS

```

```

034A 06          PUSH    ES
034B 53          PUSH    BX
034C 8B ---- R   MOV     AX,DATA          ; ESTABLISH ADDRESSING
034F 8E D8       MOV     DS,AX
0351 C6 06 0074 R 00 ASSUME  DS:DATA
0356 8A 1E 0075 R 00 MOV     DIK_STATUS1,0
035A 80 E2 7F    MOV     BL,HF_NUM       ; GET NUMBER OF DRIVES
035D 3A DA        AND     BL,7FH          ; GET DRIVE NUMBER
035F 76 22       CMP     BL,DL
0361 E8 0684 R   JBE    RDT_NOT_PRESENT ; RETURN DRIVE NOT PRESENT
0364 26: 8A 4F 02 CALL   GET_VEC          ; GET DISK PARM ADDRESS
0368 26: 8A 4F 0E MOV     AL,ES:[BX][2]   ; HEADS
036C F6 E9       IMUL   CL               ; * NUMBER OF SECTORS
036E 26: 8B 0F   MOV     CX,ES:[BX]     ; MAX NUMBER OF CYLINDERS
0371 49          DEC     CX              ; LEAVE ONE FOR DIAGNOSTICS
0372 F7 E9       IMUL   CX              ; NUMBER OF SECTORS
0374 8B CA        MOV     CX,DX          ; HIGH ORDER HALF
0376 8R D0       MOV     DX,AX          ; LOW ORDER HALF
0378 2B C0       SUB     AX,AX
037A B4 03       MOV     AH,03H        ; INDICATE FIXED DISK
037C 5B          POP     BX              ; RESTORE REGS
037D 07          POP     DS
037E 1F          POP     ES
037F F8          CLC
0380 CA 0002    RET     2              ; CLEAR CARRY
0383
0383 2B C0       SUB     AX,AX          ; DRIVE NOT PRESENT RETURN
0385 8B C8       MOV     CX,AX          ; ZERO BLOCK COUNT
0387 8B D0       MOV     DX,AX
0389 EB F1       JMP     RDT2
038B
READ_D1
PAGE
-----
; GET PARAMETERS (AH = 8)
;-----

038B GET_PARM_N LABEL NEAR
038B GET_PARM PROC FAR          ; GET DRIVE PARAMETERS
038B 1E          PUSH   DS              ; SAVE REGISTERS
038C 06          PUSH   ES
038D 53          PUSH   BX
038E 2B C0       SUB     DS:ABSO
0390 8E D8       MOV     AX,AX          ; ESTABLISH ADDRESSING
0392 F6 C2 01    TEST   DL,1           ; CHECK FOR DRIVE 1
0395 74 06       JZ     GO
0397 C4 1E 0118 R LES    BX,HF1_TBL_VEC
0398 EB 04       JMP     SHORT G1
039D C4 1E 0104 R GO:    LES    BX,HF_TBL_VEC
03A1 8B ---- R   ASSUME  DS:DATA
03A4 8E D8       MOV     AX,DATA
03A6 80 EA 80   SUB     DS,AX          ; ESTABLISH SEGMENT
03A9 80 FA 02   CMP     DL,MAX_FILE   ; TEST WITHIN RANGE
03AC 73 2C       JAE    G4
03AE C6 06 0074 R 00 MOV     DIK_STATUS1,0
03B3 26: 8B 07   MOV     AX,ES:[BX]    ; MAX NUMBER OF CYLINDERS
03B6 2D 0002    SUB     AX,2           ; ADJUST FOR 0-N
03B9 8A EB       MOV     CH,AL
03BB 25 0300   AND    AX,0300H      ; HIGH TWO BITS OF CYL
03BE D1 E8       SHR    AX,1
03C0 D1 E8       SHR    AX,1
03C2 26: 0A 47 0E OR     AL,ES:[BX][14] ; SECTORS
03C6 8A C8       MOV    CL,AL
03C8 26: 8A 77 02 OR     DH,ES:[BX][2]  ; HEADS
03CC FE 0E     DEC    DH              ; 0-N RANGE
03CE 8A 1E 0075 R MOV    DL,HF_NUM      ; DRIVE COUNT
03D2 2B C0       SUB    AX,AX
03D4
03D4 5B          POP     BX              ; RESTORE REGISTERS
03D5 07          POP     ES
03D6 1F          POP     DS
03D7 CA 0002    RET     2
03DA
03DA C6 06 0074 R 07 MOV    DIK_STATUS1,INIT_FAIL ; OPERATION FAILED
03DF B4 07       MOV    AH,INIT_FAIL
03E1 2A C0       SUB    AL,AL
03E3 2B D2       SUB    DX,DX
03E5 2B C9       SUB    CX,CX
03E7 F9         STC
03E8 EB EA       JMP    G5              ; SET ERROR FLAG
03EA
GET_PARM
PAGE
-----
; INITIALIZE DRIVE
;-----

03EA INIT_DRV PROC NEAR
03EA C6 06 0048 R 91 MOV    CMD_BLOCK+6,SET_PARM_CMD
03EF E8 0684 R   CALL   GET_VEC          ; ES:BX -> PARM BLOCK
03F2 26: 8A 47 02 MOV    AL,ES:[BX][2]   ; GET NUMBER OF HEADS
03F6 FE C8       DEC    AL              ; CONVERT TO 0-INDEX
03F8 8A 26 0047 R MOV    AH,CMD_BLOCK+5 ; GET SDH REGISTER
03FC 80 E4 F0   AND    AH,0FOH        ; CHANGE HEAD NUMBER
03FF 0A E0       OR     AH,AL           ; TO MAX HEAD
0401 8B 26 0047 R MOV    CMD_BLOCK+5,AH
0405 26: 8A 47 0E MOV    AL,ES:[BX][14] ; MAX SECTOR NUMBER
0409 A2 0043 R MOV    CMD_BLOCK+1,AL
040C 2B C0       SUB    AX,AX
040E A2 0045 R MOV    CMD_BLOCK+3,AL
0411 E8 0544 R   CALL   COMMAND         ; TELL CONTROLLER
0414 75 08       JNZ    INIT_EXIT      ; CONTROLLER BUSY ERROR
0416 EB 05DF R   CALL   NOT_BUSY        ; WAIT FOR IT TO BE DONE
0419 75 03       JNZ    INIT_EXIT      ; TIME OUT
041B EB 061E R   CALL   CHECK_STATUS
041E C3          RET
041F INIT_DRV ENDP
-----
; READ LONG (AH = 0AH)
;-----

041F RD_LONG MOV    PROC NEAR
041F C6 06 0048 R 22 CMD_BLOCK+6,READ_CMD OR ECC_MODE
0424 E9 04BB R   JMP    COMMAND1
0427 RD_LONG JMP    ENDP
-----
; WRITE LONG (AH = 0BH)
;-----

0427 WR_LONG MOV    PROC NEAR
0427 C6 06 0048 R 32 CMD_BLOCK+6,WRITE_CMD OR ECC_MODE
042C E9 04FB R   JMP    COMMAND0
042F WR_LONG JMP    ENDP

```

```

-----
; SEEK (AH = 0CH)
;
042F 06 06 0048 R 70 DISK_SEEK PROC NEAR
042F E8 0544 R MOV CMD_BLOCK+6,SEEK_CMD
0434 75 14 CALL COMMAND ; CONTROLLER BUSY ERROR
0439 E8 05A5 R JNZ DS_EXIT
043C 75 0F CALL WAIT ; TIME OUT ON SEEK
043E E8 061E R CALL CHECK_STATUS
0441 80 3E 0074 R 40 CMP DISK_STATUS1,BAD_SEEK
0446 75 05 JNE DS_EXIT
0448 C6 06 0074 R 00 MOV DISK_STATUS1,0
044D DS_EXIT: RET
044E DISK_SEEK ENDP
-----
; TEST DISK READY (AH = 010H)
;
044E E8 05DF R TST_RDY PROC NEAR
0451 75 11 JNZ TR_EX ; WAIT FOR CONTROLLER
0453 A0 0047 R MOV AL,CMD_BLOCK+5 ; SELECT DRIVE
0456 BA 01F6 MOV DX,HF_PORT+6
0459 EE OUT DX,AL
045D E8 0630 R CALL CHECK_ST ; CHECK STATUS ONLY
045D 75 05 JNZ TR_EX
045F C6 06 0074 R 00 MOV DISK_STATUS1,0 ; WIPE OUT DATA CORRECTED ERROR
0464 C3 TR_EX: RET
0465 TST_RDY ENDP
-----
; RECALIBRATE (AH = 011H)
;
0465 C6 06 0048 R 10 HDISK_RECAL PROC NEAR
046A E8 0544 R MOV CMD_BLOCK+6,RECAL_CMD
046D 75 14 CALL COMMAND ; START THE OPERATION
046F E8 05A5 R JNZ RECAL_EXIT ; ERROR
0472 75 0F CALL WAIT ; WAIT FOR COMPLETION
0474 E8 061E R JNZ RECAL_EXIT ; TIME OUT
0477 80 3E 0074 R 40 CALL CHECK_STATUS
047C 75 05 CMP DISK_STATUS1,BAD_SEEK ; SEEK NOT COMPLETE
047E C6 06 0074 R 00 JNE RECAL_EXIT ; IS OK
0483 MOV DISK_STATUS1,0
0488 C3 RECAL_EXIT: RET
0489 HDISK_RECAL ENDP
-----
; CONTROLLER DIAGNOSTIC (AH = 14H)
;
0489 E4 A1 CTRL_DIAGNOSTIC PROC NEAR ; ** IO DELAY NOT REQUIRED **
048B 24 BF IN AL,INT_CTL_PORT+1 ; TURN ON SECOND INTERRUPT CHIP
048D E6 A1 AND AL,0BFH
048F E4 21 OUT INT_CTL_PORT+1,AL
0491 24 FB IN AL,INT1_CTL_PORT+1 ; LET INTERRUPTS PASS THRU TO
0493 E6 21 AND AL,0FBH ; SECOND CHIP
0495 E8 05DF R OUT INT_CTL_PORT+1,AL
0498 75 1A CALL NOT_BUSY ; WAIT FOR CARD
049A BA 01F7 MOV CD_ERR ; BAD CARD
049B 80 90 JNZ CD_ERR
049F EE MOV DX,HF_PORT+7 ; START DIAGNOSE
04A0 E8 05DF R MOV AL,DIAG_CMD
04A3 B4 80 OUT DX,AL ; WAIT FOR IT TO COMPLETE
04A5 75 0F CALL NOT_BUSY ; TIME OUT ON DIAGNOSTIC
04A7 BA 01F1 MOV AH,TIME_OUT ; GET ERROR REGISTER
04AA EC JNZ CD_EXIT
04AD A2 008D R IN HF_ERROR,AL ; SAVE IT
04AE B4 00 MOV AH,0
04B0 3C 01 CMP AL,1 ; CHECK FOR ALL OK
04B2 74 02 JE SHORT CD_EXIT
04B4 B4 20 MOV AH,BAD_CNTRLR
04B6 CD_ERR: MOV DISK_STATUS1,AH
04B8 C3 CD_EXIT: RET
04BB CTRL_DIAGNOSTIC ENDP
-----
; COMMAND1
; REPEATEDLY INPUTS DATA TIL NSECTOR
; RETURNS ZERO
;
04BB COMMAND1:
04BB CALL CHECK_DMA ; CHECK 64K BOUNDARY ERROR
04BE 72 3A JC CMD_ABORT
04C0 8B FB MOV DI,DX
04C2 E8 0544 R CALL COMMAND ; OUTPUT COMMAND
04C5 75 33 JNZ CMD_ABORT
04C7 CMD_11:
04C7 CALL WAIT ; WAIT FOR DATA REQUEST INT
04CA 75 2E JNZ TM_OUT ; TIME OUT
04CC B9 0100 MOV CX,256D ; SECTOR SIZE IN WORDS
04CF BA 01F0 MOV DX,HF_PORT
04D2 FC CLD
REP_INSW ; GET THE SECTOR
+ DB 0F3H,06DH
04D3 F3 6D TEST DB_CMD_BLOCK+6,ECC_MODE ; CHECK FOR NORMAL INPUT
04D4 74 12 JZ CMD_13
04DC E8 0608 R CALL WAIT_DRQ ; WAIT FOR DATA REQUEST
04DF 72 19 JC TM_OUT
04E1 BA 01F0 MOV DX,HF_PORT
04E4 B9 0004 MOV CX,4 ; GET ECC BYTES
04E7 EC IN AL,DX
04E9 26: 88 05 MOV ES:BYTE PTR [DI],AL ; GO SLOW FOR BOARD
04EB 47 INC DI
04EC E2 F9 LOOP CMD_12
04EE E8 061E R CALL CHECK_STATUS
04F1 75 07 JNZ CMD_ABORT ; ERROR RETURNED
04F3 F6 06 008C R 80 TEST HF_STATUS,ST_BUSY ; CHECK FOR MORE
04F8 75 CD JNZ SHORT CMD_11
04FA CMD_ABORT:
04FA TM_OUT: RET
04FA C3
-----
; COMMAND0
; REPEATEDLY OUTPUTS DATA TIL NSECTOR
; RETURNS ZERO
;

```

```

04FB      E8 068F R
04FE      72 FA
0500      8B F3
0502      E8 0544 R
0505      75 F3
0507      E8 0608 R
050A      72 EE
050C      1E
050D      06
050E      1F
050F      B9 0100
0512      BA 01F0
0515      FC

0516      F3 6F
0518      1F
0519      F6 06 0048 R 02
051E      74 12
0520      E8 0608 R
0523      72 D5
0525      BA 01F0
0528      B9 0004
052B      26: BA 04
052E      EE
052F      46
0530      E2 F9
0532
0532      E8 05A5 R
0535      75 C3
0537      E8 061E R
053A      75 BE
053C      F6 06 008C R 08
0541      75 C9
0543      C3

```

```

-----
COMMANDO:
CALL CHECK_DMA ; CHECK 64K BOUNDARY ERROR
JC CMD_ABORT
S1, BX
CMD_OF: MOV ; OUTPUT COMMAND
CALL COMMAND
JNZ CMD_ABORT ; WAIT FOR DATA REQUEST
CALL WAIT_DRQ ; TOO LONG
JC TM_OUT
CMD_O1: PUSH DS ;
PUSH ES ; MOVE ES TO DS
POP DS
MOV CX, 256D ; PUT THE DATA OUT TO THE CARD
MOV DX, HF_PORT
CLD
REP_OUTSW
+ DB 0F3H, 06FH
POP DS ; RESTORE DS
TEST CMD_BLOCK+6, ECC_MODE ; CHECK FOR NORMAL OUTPUT
JZ CMD_O3
CALL WAIT_DRQ ; WAIT FOR DATA REQUEST
JC TM_OUT
MOV DX, HF_PORT
MOV CX, 4 ; OUTPUT THE ECC BYTES
CMD_O2: MOV AL, ES:BYTE PTR [SI]
OUT DX, AL
INC SI
LOOP CMD_O2
CMD_O3: CALL WAIT ; WAIT FOR SECTOR COMPLETE INT
JNZ TM_OUT ; ERROR RETURNED
CALL CHECK_STATUS
JNZ CMD_ABORT
TEST HF_STATUS, ST_DRQ ; CHECK FOR MORE
JNZ SHORT CMD_O1
RET

```

```

-----
: COMMAND
: THIS ROUTINE OUTPUTS THE COMMAND BLOCK
:
: OUTPUT
: BL = STATUS
: BH = ERROR REGISTER
:
-----

```

```

0544      53
0545      B9 0600
0548
0548      51
0549      E8 044E R
054C      59
054D      74 08
054F      80 3E 0074 R 80
0554      74 43
0556      E2 F0
0558      EB 44
055A
055A      5B
055B      57
055C      C6 06 008E R 00
0561      E4 A1
0563      24 BF
0565      E6 A1
0567      E4 21
0569      24 FB
056B      E6 21
056D      BF 0042 R
0570      BA 01F1
0573      F6 06 0076 R C0
0578      74 12
057A      A0 0048 R
057D      24 F0
057F      3C 20
0581      72 09
0583      3C 40
0585      77 05
0587      80 0E 0048 R 01
058C
058C      BA 05
058E      EE
058F      47
0590      42
0591      81 FA 01F8
0595      75 F5
0597      5F
0598      C3
0599
0599      C6 06 0074 R 20
059E
059E      5B
059F      80 3E 0074 R 00
05A4      C3
05A5

```

```

COMMAND PROC NEAR
BX
PUSH
MOV CX, DELAY_2 ; WAIT FOR SEEK COMPLETE AND READY
; SET INITIAL DELAY BEFORE TEST
COMMAND1:
PUSH CX ; SAVE LOOP COUNT
CALL TST_RDY ; CHECK DRIVE READY
POP CX
JZ COMMAND2 ; DRIVE IS READY
DISK_STATUS1, TIME_OUT ; TST_RDY TIMED OUT--GIVE UP
CMD_TIMEOUT
COMMAND1
SHORT COMMAND4 ; KEEP TRYING FOR A WHILE
; ITS NOT GOING TO GET READY
COMMAND2:
POP BX
PUSH DI
HF_INT_FLAG, 0 ; ** IO DELAY NOT REQUIRED **
IN AL, INT_CTL_PORT+1 ; RESET INTERRUPT FLAG
AND AL, 0BFH ; TURN ON SECOND INTERRUPT CHIP
OUT AL, INT_CTL_PORT+1, AL ; LET INTERRUPTS PASS THRU TO
IN AL, INT_CTL_PORT+1 ; SECOND CHIP
AND AL, 0BFH
OUT INT_CTL_PORT+1, AL
MOV MOV ; INDEX THE COMMAND TABLE
DX, HF_PORT+1 ; DISK ADDRESS
TEST CONTROL_BYTE, 0C0H ; CHECK FOR RETRY SUPPRESSION
JZ COMMAND3
AL, CMD_BLOCK+6 ; YES-GET OP CODE
AND AL, 0F0H ; GET RID OF MODIFIERS
CMP AL, 20H ; 20H-40H IS READ, WRITE, VERIFY
JNB COMMAND3
CMP AL, 40H
JA COMMAND3
OR CMD_BLOCK+6, NO_RETRIES ; VALID OP FOR RETRY SUPPRESS
COMMAND3:
MOV AL, [DI] ; GET THE COMMAND STRING
OUT DX, AL ; GIVE IT TO CONTROLLER
INC DI ; NEXT BYTE
INC DX ; NEXT DISK REGISTER
CMP DX, HF_PORT+8 ; ALL DONE?
JNZ COMMAND3 ; NO--GO DO NEXT ONE
POP DI ; ZERO FLAG IS SET
CMD_TIMEOUT:
MOV DISK_STATUS1, BAD_CNTRL
COMMAND4:
POP BX
CMP DISK_STATUS1, 0 ; SET CONDITION CODE FOR CALLER
RET
COMMAND ENDP

```

```

-----
: WAIT FOR INTERRUPT
:
-----

```

```

05A5
05A5      FB
05A6      2B C9
05A8      FB
05A9      B8 9000
05AC      CD 15
05AE      72 28
05B0      F6 06 008E R 80
05B5      75 11
05B7      B3 20

05B9      F6 06 008E R 80
05BE      E1 F9
05C0      75 06
05C2      FE C8
05C4      75 F3
05C6      EB 10
05C8      C6 06 0074 R 00
05CD      C6 06 008E R 00
05D2      80 3E 0074 R 00
05D3      C3
05D8      C6 06 0074 R 80
05DD      EB F3
05DF

```

```

WAIT PROC NEAR
STI ; MAKE SURE INTERRUPTS ARE ON
SUB CX, CX ; SET INITIAL DELAY BEFORE TEST
CLC
MOV AX, 9000H ; DEVICE WAIT INTERRUPT
INT 15H
JC WT3 ; DEVICE TIMED OUT
HF_INT_FLAG, 80H ; TEST FOR INTERRUPT ALREADY
JNZ WT2
MOV BL, DELAY_1 ; SET DELAY COUNT
;
;
; WAIT LOOP
WT1: TEST HF_INT_FLAG, 80H ; TEST FOR INTERRUPT
LOOPZ WT1
JNZ WT2 ; INTERRUPT--LETS GO
DEC BL
JNZ SHORT WT3 ; KEEP TRYING FOR A WHILE
JMP SHORT WT3
WT2: MOV DISK_STATUS1, 0
MOV HF_INT_FLAG, 0
WTX: MOV D1SK_STATUS1, 0 ; SET CONDITION CODE FOR CALLER
RET
WT3: MOV DISK_STATUS1, TIME_OUT ; REPORT TIME OUT ERROR
JMP WTX
WAIT ENDP

```

```

-----
; WAIT FOR CONTROLLER NOT BUSY
-----
05DF FB          NOT_BUSY PROC NEAR
05DF 53          STI
05E1 B3 20      PUSH BX
05E3 2B C9      MOV BL,DELAY_1
05E5 BA 01F7    SUB CX,CX
05E8 EC         MOV DX,HF_PORT+7
05E9 A8 80      IN AL,DX
05EB E0 FB     TEST AL,ST_BUSY
05ED 74 06     LOOPNZ NB1
05EF FE CB     JZ NB2
05F1 75 F5     DEC BL
05F3 EB 0C     JNZ NB1
05F5 F6 06 0074 R 00 MOV SHORT NB3
05FA 5B        NBX: POP BX
05FB 80 3E 0074 R 00 CMP DISK_STATUS1,0
0600 C3        RET
0601 C6 06 0074 R 80 NB3: MOV DISK_STATUS1,TIME_OUT
0606 EB F2     JMP NBX
0608          NOT_BUSY ENDP

```

```

-----
; WAIT FOR DATA REQUEST
-----
0608 B9 0100    WAIT_DRQ PROC NEAR
0608 BA 01F7    MOV CX,DELAY_3
060E EC         MOV DX,HF_PORT+7
0610 A8 08      WQ_1: IN AL,DX
0611 75 09     TEST AL,ST_DRQ
0613 E2 F9     JNZ WQ_OK
0615 C6 06 0074 R 80 WQ_1: MOV DISK_STATUS1,TIME_OUT
061A F9        RET
061B C3        WQ_OK: CLC
061C F8        RET
061E C3        WAIT_DRQ ENDP

```

```

-----
; CHECK HARD FILE STATUS
-----
061E E8 0630 R  CHECK_STATUS PROC NEAR
0621 75 07     CALL CHECK_ST
0623 A8 01     JNZ CHECK_S1
0625 74 03     TEST AL,ST_ERROR
0627 E8 0664 R CALL CHECK_ER
062A 80 3E 0074 R 00 CHECK_S1: CMP DISK_STATUS1,0
062F C3        RET
0630          CHECK_STATUS ENDP

```

```

-----
; CHECK HARD FILE STATUS BYTE
-----
0630 BA 01F7    CHECK_ST PROC NEAR
0633 EC         MOV DX,HF_PORT+7
0634 A2 008B R  IN AL,DX
0637 B4 00     MOV HF_STATUS,AL
0639 A8 80     TEST AH,0
063B 75 1A     JNZ CKST_EXIT
063D B4 CC     MOV AH,WRITE_FAULT
063F A8 20     TEST AL,ST_WRT_FLT
0641 75 14     JNZ CKST_EXIT
0643 B4 AA     MOV AH,NOT_RDY
0645 A8 40     TEST AL,ST_READY
0647 74 0E     JZ CKST_EXIT
0649 B4 40     MOV AH,BAD_SEEK
064B A8 10     TEST AL,ST_SEEK_COMPL
064D 74 08     JZ CKST_EXIT
064F B4 11     MOV AH,DATA_CORRECTED
0651 A8 04     TEST AL,ST_CORRECTD
0653 75 02     JNZ CKST_EXIT
0655 B4 00     MOV AH,0
0657          CKST_EXIT:
0657 88 26 0074 R MOV DISK_STATUS1,AH
065B 80 FC 11  CMP AH,DATA_CORRECTED
065E 74 03     JZ CKST_EXIT
0660 80 FC 00  CMP AH,0
0663          CKST_EXIT: RET
0664          CHECK_ST ENDP

```

```

-----
; CHECK HARD FILE ERROR REGISTER
-----
0664 BA 01F1    CHECK_ER PROC NEAR
0667 EC         MOV DX,HF_PORT+1
0668 A2 008D R  MOV AL,DX
066B 53        PUSH BX
066C B9 0008    MOV CX,8
066F D0 E0     CK1: SHL AL,1
0671 72 02     JC CK2
0673 E2 FA     LOOP CK1
0675 BB 0686 R CK2: MOV BX,OFFSET_ERR_TBL
0678 03 D9     ADD BX,CX
067A 2E: 8A 27  MOV AH,BYTE PTR CS:[BX]
067D 88 26 0074 R CKEX: MOV DISK_STATUS1,AH
0681 5B        POP BX
0682 80 FC 00  CMP AH,0
0685 C3        RET
0686          ERR_TBL DB NO_ERR
0687 02 40 01 BB DB BAD_ADDR_MARK,BAD_SEEK,BAD_CMD,UNDEF_ERR
0688 04 BB 10 AA DB RECORD_NOT_FND,UNDEF_ERR,BAD_ECC,BAD_SECTOR
068F          CHECK_ER ENDP

```

```

-----
; CHECK DMA
; -CHECK ES:BX AND # SECTORS TO MAKE SURE THAT IT WILL
; FIT WITHOUT SEGMENT OVERFLOW.
; -ES:BX HAS BEEN REVISED TO THE FORMAT SSSS:000X
; -OK IF # SECTORS < 80H (7FH IF LONG READ OR WRITE)
; -OK IF # SECTORS = 80H (7FH) AND BX <= 00H (04H)
; -ERROR OTHERWISE
-----
068F          CHECK_DMA PROC NEAR
068F 50        PUSH AX
0690 B8 8000    MOV AX,8000H
0693 F6 06 0048 R 02 TEST CMD_BLOCK+6,ECC_MODE

```

```

; SAVE REGS
; AH = MAX # SECTORS
; AL = MAX OFFSET

```

```

0698 74 03          JZ      CKD1
069A 88 7F04      MOV     AX,7F0H          ; ECC IS 4 MORE BYTES
069D 3A 26 0043 R  CKD1:  CMP     AH,CMD_BLOCK+1 ; NUMBER OF SECTORS
06A1 77 06          JA      CKDOK_          ; IT WILL FIT
06A3 72 07          JB      CKDERR         ; TOO MANY
06A5 3A C3         CMP     AL,BL           ; CHECK OFFSET ON MAX SECTORS
06A7 72 03         JB      CKDERR         ; ERROR
06A9 F8           CLC                    ; CLEAR CARRY
06AA 58           POP     AX                    ; NORMAL RETURN
06AB C3           RET                     ; INDICATE ERROR
06AC F9           CKDERR: STC
06AD C6 06 0074 R 09 MOV     DISK_STATUS1,DMA_BOUNDARY
06B2 58           POP     AX
06B3 C3           RET
06B4              CHECK_DMA  ENDP

```

```

-----
; SET UP ES:BX->DISK PARMS :
GET_VEC PROC NEAR
06B4 2B C0      SUB     AX,AX          ; GET DISK PARAMETER ADDRESS
06B6 8E C0      MOV     ES,AX
          ASSUME ES:ABS0
06B8 F6 C2 01  TEST   DL,1
06BB 74 07      JZ      GV_0
06BD 26: C4 1E 0118 R  LES   BX,HF1_TBL_VEC ; ES:BX -> DRIVE PARAMETERS
06C2 EB 05      JMP     SHORT GV_EXIT
06C4 26: C4 1E 0104 R  LES   BX,HF1_TBL_VEC ; ES:BX -> DRIVE PARAMETERS
06C9          GV_EXIT: RET
06CA          GET_VEC ENDP
-----
; HARD DISK INTERRUPT ROUTINE :

```

```

HD_INT PROC NEAR
06CA 50      PUSH  AX
06CB 1E      PUSH  DS
06CC B8 ---- R  MOV   AX,DATA
06CF 8E D8  MOV   DS,AX
06D1 C6 06 008E R FF  MOV   HF_INT_FLAG,OFFH ; ALL DONE
06D6 B0 20  MOV   AL,E01           ; NON-SPECIFIC END OF INTERRUPT
06D8 E6 A0  OUT   INT_CTL_PORT,AL ; FOR CONTROLLER #2
06DA EB 00  JMP   S+2             ; WAIT
06DC E6 20  OUT   INT1_CTL_PORT,AL ; FOR CONTROLLER #1
06DE 1F      POP   DS
06DF FB      STI                    ; RE-ENABLE INTERRUPTS
06E0 88 9100 MOV   AX,9100H        ; DEVICE POST
06E3 CD 15  INT   15H             ; INTERRUPT
06E5 58      POP   AX
06E6 CF      IRET                  ; RETURN FROM INTERRUPT
06E7          HD_INT ENDP

```

```

06E7 31 2F 31 31 2F 38  DB      '1/11/84' ; RELEASE MARKER
06EE 34
06EE          END_ADDRESS LABEL BYTE
06EE          CODE ENDS
06EE          ENDS

```



PUBLIC KEYBOARD_IO_1
 PUBLIC KB_INT_1
 PUBLIC K16

0000

CODE SEGMENT BYTE PUBLIC
 EXTRN DDS:NEAR
 EXTRN START_1:NEAR
 EXTRN K6:BYTE
 EXTRN K6L:ABS
 EXTRN K7:BYTE
 EXTRN K8:BYTE
 EXTRN K9:BYTE
 EXTRN K10:BYTE
 EXTRN K11:BYTE
 EXTRN K12:BYTE
 EXTRN K13:BYTE
 EXTRN K14:BYTE
 EXTRN K15:BYTE

```

;----- INT 16 -----
; KEYBOARD I/O
; THESE ROUTINES PROVIDE KEYBOARD SUPPORT
; INPUT
; (AH)=0 READ THE NEXT ASCII CHARACTER STRUCK FROM THE KEYBOARD
; RETURN THE RESULT IN (AL), SCAN CODE IN (AH)
; (AH)=1 SET THE Z FLAG TO INDICATE IF AN ASCII CHARACTER IS AVAILABLE
; TO BE READ.
; (ZF)=1 -- NO CODE AVAILABLE
; (ZF)=0 -- CODE IS AVAILABLE
; IF ZF = 0, THE NEXT CHARACTER IN THE BUFFER TO BE READ IS
; IN AX, AND THE ENTRY REMAINS IN THE BUFFER
; (AH)=2 RETURN THE CURRENT SHIFT STATUS IN AL REGISTER
; THE BIT SETTINGS FOR THIS CODE ARE INDICATED IN THE
; EQUATES FOR KB_FLAG
; OUTPUT
; AS NOTED ABOVE, ONLY AX AND FLAGS CHANGED
; ALL REGISTERS RETAINED
;-----
; ASSUME CS:CODE,DS:DATA
    
```

```

0000 KEYBOARD_IO_1 PROC FAR ;>>> ENTRY POINT FOR ORG 0E82EH
0000 STI ; INTERRUPTS BACK ON
0001 PUSH DS ; SAVE CURRENT DS
0002 PUSH BX ; SAVE BX TEMPORARILY
0003 CALL DDS ; ESTABLISH POINTER TO DATA REGION
0006 OR AH,AH ; AH=0
0008 JZ K1B ; ASCII_READ
000A DEC AH ; AH=1
000C JZ K2 ; ASCII_STATUS
000E DEC AH ; AH=2
0010 JZ K3 ; SHIFT STATUS
0012 POP BX ; RECOVER REGISTER
0013 POP DS
0014 IRET ; INVALID COMMAND
    
```

```

;----- READ THE KEY TO FIGURE OUT WHAT TO DO
0015 MOV BX,BUFFER_HEAD ; GET POINTER TO HEAD OF BUFFER
0019 CMP BX,BUFFER_TAIL ; TEST END OF BUFFER
001D JNE K1C ; IF ANYTHING IN BUFFER DONT DO INTERRUPT

;
001F MOV AX,09002H ; MOVE IN WAIT CODE & TYPE
0022 INT 15H ; PERFORM OTHER FUNCTION

0024 ; ASCII_READ
0024 STI ; INTERRUPTS BACK ON DURING LOOP
0025 NOP ; ALLOW AN INTERRUPT TO OCCUR
0026 FA ; INTERRUPTS BACK OFF
0027 MOV BX,BUFFER_HEAD ; GET POINTER TO HEAD OF BUFFER
0028 CMP BX,BUFFER_TAIL ; TEST END OF BUFFER
002F PUSH BX ; SAVE ADDRESS
0030 PUSHF ; SAVE FLAG
0031 CALL MAKE_LED ; GO GET MODE INDICATOR DATA BYTE
0034 MOV BL,KB_FLAG_2 ; GET PREVIOUS BITS
0038 XOR BL,AL ; SEE IF ANY DIFFERENT
003A AND BL,07H ; ISOLATE INDICATOR BITS
003D JZ K1A ; IF NO CHANGE BYPASS UPDATE

;
003F EB 0484 R ; CALL SND_LED1 ; GO TURN ON MODE INDICATORS
0042 FA ; DISABLE INTERRUPTS
0043 9D ; RESTORE FLAGS
0044 5B ; RESTORE ADDRESS
0045 74 DD ; LOOP UNTIL SOMETHING IN BUFFER

;
0047 MOV AX,[BX] ; GET SCAN CODE AND ASCII CODE
0049 CALL K4 ; MOVE POINTER TO NEXT POSITION
004C MOV BUFFER_HEAD,BX ; STORE VALUE IN VARIABLE

;
0050 POP BX ; RECOVER REGISTER
0051 POP DS ; RECOVER SEGMENT
0052 IRET ; RETURN TO CALLER
    
```

```

;----- ASCII STATUS
0053 K2: CL1 ; INTERRUPTS OFF
0054 MOV BX,BUFFER_HEAD ; GET HEAD POINTER
0058 CMP BX,BUFFER_TAIL ; IF EQUAL (Z=1) THEN NOTHING THERE
005C MOV AX,[BX] ; SAVE FLAGS
005E 9C ;

;
005F PUSH AX ; SAVE CODE
0060 CALL MAKE_LED ; GO GET MODE INDICATOR DATA BYTE
0063 MOV BL,KB_FLAG_2 ; GET PREVIOUS BITS
0067 XOR BL,AL ; SEE IF ANY DIFFERENT
0069 AND BL,07H ; ISOLATE INDICATOR BITS
006C JZ SK2 ; IF NO CHANGE BYPASS UPDATE

;
006E CALL SND_LED1 ; GO TURN ON MODE INDICATORS
0071 POP AX ; RESTORE CODE
0072 9D ; RESTORE FLAGS
0073 STI ; INTERRUPTS BACK ON
0074 POP BX ; RECOVER REGISTER
0075 POP DS ; RECOVER SEGMENT
0076 CA 0002 ; THROW AWAY FLAGS
    
```

```

;----- SHIFT STATUS
0079 K3: MOV AL,KB_FLAG ; GET THE SHIFT STATUS FLAGS
007C POP BX ; RECOVER REGISTER
007D POP DS ; RECOVER REGISTERS
007E IRET ; RETURN TO CALLER
007F
    
```

KEYBOARD_IO_1 ENDP

```

;----- INCREMENT A BUFFER POINTER
007F      43      K4      PROC      NEAR
007F      43      INC      BX          ; MOVE TO NEXT WORD IN LIST
0080      43      INC      BX
0081      3B 1E 0082 R      CMP      BX,BUFFER_END ; AT END OF BUFFER?
0085      75 04      JNE      K5          ; NO, CONTINUE
0087      8B 1E 0080 R      MOV      BX,BUFFER_START ; YES, RESET TO BUFFER BEGINNING
0088      C3      K5:      RET
008C      K4      ENDP

;----- KEYBOARD INTERRUPT ROUTINE
008C      FB      KB_INT_1 PROC      FAR          ; ENABLE INTERRUPTS
008D      55      STI
008E      50      PUSH     BP
008F      53      PUSH     AX
0090      51      PUSH     BX
0091      52      PUSH     DX
0092      56      PUSH     SI
0093      57      PUSH     DI
0094      1E      PUSH     DS
0095      06      PUSH     ES
0096      FC      CLD          ; FORWARD DIRECTION
0097      E8 0000 E      CALL     DDS          ; GET UP ADDRESSING
009A      80 AD      MOV      AL,_DIS_KBD ; DISABLE THE KEYBOARD
009C      E8 0498 R      CALL     SHIP_IT     ; EXECUTE DISABLE

;----- WAIT FOR COMMAND TO ACCEPTED
009F      FA      K1:      CLI          ; DISABLE INTERRUPTS
00A0      2B C9      SUB      CX,CX      ;
00A2      E4 64      IN       AL,_STATUS_PORT ;
00A4      A8 02      TEST     AL,_INPT_BUF_FULL ;
00A6      E0 FA      LOOPNZ  KB_INT_01    ; WAIT FOR COMMAND TO BE ACCEPTED

00A8      E4 60      IN       AL,_KB_DATA     ; READ IN THE CHARACTER
00AA      FB      STI          ; ENABLE INTERRUPTS AGAIN

;-----CHECK FOR A RESEND COMMAND TO KEYBOARD
00AB      3C FE      CMP      AL,_KB_RESEND  ; IS THE INPUT A RESEND
00AD      74 0D      JE       K2          ; GO IF RESEND

;----- CHECK FOR RESPONSE TO A COMMAND TO KEYBOARD
00AF      3C FA      CMP      AL,_KB_ACK     ; IS THE INPUT AN ACKNOWLEDGE
00B1      75 12      JNZ     KB_INT_2      ; GO IF NOT

;----- A COMMAND TO THE KEYBOARD WAS ISSUED
00B3      FA      CLI          ; DISABLE INTERRUPTS
00B4      80 0E 0097 R 10 OR      KB_FLAG_2,_KB_FA ; INDICATE ACK RECEIVED
00B9      E9 01E2 R      JMP      K26         ; RETURN IF NOT (THIS ACK RETURNED FOR DATA)

;----- RESEND THE LAST BYTE
00BC      FB      KB_INT_4:
00BC      FA      CLI          ; DISABLE INTERRUPTS
00BD      80 0E 0097 R 20 OR      KB_FLAG_2,_KB_FE ; INDICATE RESEND RECEIVED
00C2      E9 01E2 R      JMP      K26         ; RETURN IF NOT (THIS ACK RETURNED FOR DATA)

00C5      FB      KB_INT_2:
;-----UPDATE MODE INDICATORS IF CHANGE IN STATE
00C5      50      PUSH     AX          ; SAVE DATA IN
00C6      E8 048A R      CALL    MAKE_LED     ; GO GET MODE INDICATOR DATA BYTE
00C9      8A 1E 0097 R  MOV     BL,_KB_FLAG_2 ; GET PREVIOUS BITS
00CD      32 D8      XOR     BL,AL         ; SEE IF ANY DIFFERENT
00CF      80 E3 07      AND     BL,07H       ; ISOLATE INDICATOR BITS
00D2      74 03      JZ      UPO          ; IF NO CHANGE BYPASS UPDATE
;
00D4      E8 0439 R      CALL    SMD_LED     ; GO TURN ON MODE INDICATORS
00D7      58      POP      AX          ; RESTORE DATA IN
00D8      8A AL      MOV     AH,AL        ; SAVE SCAN CODE IN AH ALSO

;----- TEST FOR OVERRUN SCAN CODE FROM KEYBOARD
00DA      3C FF      CMP      AL,_OFFH     ; IS THIS AN OVERRUN CHAR
00DC      75 03      JNZ     K16         ; NO, TEST FOR SHIFT KEY
00DE      E9 03D6 R      JMP     K62         ; BUFFER_FULL_BEep

;----- TEST FOR SHIFT KEYS
00E1      K16:      AND     AL,_07FH     ; TEST_SHIFT
00E3      0E      PUSH    CS          ; TURN OFF THE BREAK BIT
00E4      07      POP     ES          ; ESTABLISH ADDRESS OF SHIFT TABLE

;----- TEST FOR SYSTEM KEY
00E5      3C 54      CMP      AL,_SYS_KEY  ; IS IT THE SYSTEM KEY?
00E7      75 3D      JNZ     K16A       ; CONTINUE IF NOT
;
00E9      F6 C4 80      TEST    AH,_080H    ; CHECK IF THIS A BREAK CODE
00EC      75 21      JNZ     K16C       ; DONT TOUCH SYSTEM INDICATOR IF TRUE
;
00EE      F6 06 0018 R 04 TEST    KB_FLAG_1,SYS_SHIFT ; SEE IF IN SYSTEM KEY HELD DOWN
00F3      75 17      JNZ     K16B       ; IF YES, DONT PROCESS SYSTEM INDICATOR
;
00F5      80 0E 0018 R 04 OR      KB_FLAG_1,SYS_SHIFT ; INDICATE SYSTEM KEY DEPRESSED
00FA      B0 20      MOV     AL,_E01     ; END OF INTERRUPT COMMAND
00FC      E6 20      OUT     020H,_AL    ; SEND COMMAND TO INTERRUPT CONTROL PORT
;
00FE      80 AE      MOV     AL,_ENA_KBD ; INSURE KEYBOARD IS ENABLED
0100      E8 0698 R      CALL    SHIP_IT     ; EXECUTE ENABLE
0103      B8 8500      MOV     AX,_08500H  ; FUNCTION VALUE FOR MAKE OF SYSTEM KEY
0106      FB      STI          ; MAKE SURE INTERRUPTS ENABLED
0107      CD 15      INT     15H        ; USER INTERRUPT
0109      E9 01E2 R      JMP     K27A       ; END PROCESSING
010C      E9 01E2 R      K16B:  JMP     K26        ; IGNORE SYSTEM KEY
;
010F      80 26 0018 R FB AND     KB_FLAG_1,_NOT_SYS_SHIFT ; TURN OFF SHIFT KEY HELD DOWN
0114      B0 20      MOV     AL,_E01     ; END OF INTERRUPT COMMAND
0116      E6 20      OUT     020H,_AL    ; SEND COMMAND TO INTERRUPT CONTROL PORT
;
0118      80 AE      MOV     AL,_ENA_KBD ; INSURE KEYBOARD IS ENABLED
011A      E8 0498 R      CALL    SHIP_IT     ; EXECUTE ENABLE
011D      B8 8501      MOV     AX,_08501H  ; FUNCTION VALUE FOR BREAK OF SYSTEM KEY
0120      FB      STI          ; MAKE SURE INTERRUPTS ENABLED
0121      CD 15      INT     15H        ; USER INTERRUPT

```

```

0123  E9 01EC R      JMP      K27A          ; IGNORE SYSTEM KEY
;
0126  BF 0000 E      K16A: MOV    D1,OFFSET K6   ; SHIFT KEY TABLE
0129  B9 0000 E      MOV    CX,OFFSET K6L  ; LENGTH
012C  F2/ AE 0000 E  REPNE  SCASB          ; LOOK THROUGH THE TABLE FOR A MATCH
012E  8A C4          MOV    AL,AH          ; RECOVER SCAN CODE
0130  74 03          JNE   K17             ; JUMP IF MATCH FOUND
0132  E9 01CE R      JMP    K25            ; IF NO MATCH, THEN SHIFT NOT FOUND
;
;----- SHIFT KEY FOUND
0135  81 EF 0001 E    K17:  SUB    D1,OFFSET K6+1 ; ADJUST PTR TO SCAN CODE MTCX
0139  2E/ 8A A5 0000 E MOV    AH,CS:K7[D1]   ; GET MASK INTO AH
013E  A8 80          TEST   AL,80H         ; TEST FOR BREAK KEY
0140  74 02          JZ    K17C            ; BREAK SHIFT FOUND
0142  EB 63          JMP    SHORT K23      ; CONTINUE
;
;----- DETERMINE SET OR TOGGLE
0144  80 FC 10          K17C: CMP    AH,SCROLL_SHIFT
0147  73 07          JAE   K18             ; IF SCROLL SHIFT OR ABOVE, TOGGLE KEY
;
;----- PLAIN SHIFT KEY, SET SHIFT ON
0149  08 26 0017 R      OR     KB_FLAG,AH     ; TURN ON SHIFT BIT
014D  E9 01E2 R      JMP    K26            ; INTERRUPT_RETURN
;
;----- TOGGLED SHIFT KEY, TEST FOR 1ST MAKE OR NOT
0150  F6 06 0017 R 04   K18:  TEST   KB_FLAG, CTL_SHIFT
0155  74 03          JZ    K18A            ; SHIFT-TOGGLE
;
;
0157  EB 75 90          JMP    K25            ; JUMP IF CTL STATE
015A  3C 52          CMP    AL, INS_KEY   ; CHECK FOR INSERT KEY
015C  75 25          JNZ   K22            ; JUMP IF NOT INSERT KEY
015E  F6 06 0017 R 08   K18A: TEST   KB_FLAG, ALT_SHIFT
0163  74 03          JZ    K19            ; CHECK FOR ALTERNATE SHIFT
0165  EB 67 90          JMP    K25            ; JUMP IF NOT ALTERNATE SHIFT
0168  F6 06 0017 R 20   K19:  TEST   KB_FLAG, NUM_STATE
016D  75 0D          JNZ   K21            ; CHECK FOR BASE STATE
016F  F6 06 0017 R 03   K19:  TEST   KB_FLAG, LEFT_SHIFT+ RIGHT_SHIFT
0174  74 0D          JZ    K22            ; JUMP IF BASE STATE
;
0176  B8 5230          K20:  MOV    AX, 5230H     ; NUMERIC ZERO, NOT INSERT KEY
0179  E9 0375 R      JMP    K57            ; PUT OUT AN ASCII ZERO
017C  F6 06 0017 R 03   K21:  TEST   KB_FLAG, LEFT_SHIFT+ RIGHT_SHIFT
0181  74 F3          JZ    K22            ; JUMP NUMERIC, NOT INSERT
;
0183  84 26 0018 R      K22:  TEST   AH,KB_FLAG_1 ; SHIFT TOGGLE KEY HIT; PROCESS IT
0183  74 02          JZ    K22A0          ; IS KEY ALREADY DEPRESSED
0189  EB 57          JMP    SHORT K26     ; GO IF NOT
018B  08 26 0018 R      K22A0: OR     KB_FLAG_1,AH ; JUMP IF KEY ALREADY DEPRESSED
018F  30 26 0017 R      XOR    KB_FLAG,AH    ; INDICATE THAT THE KEY IS DEPRESSED
;
;----- TOGGLE LED IF CAPS OR NUM KEY DEPRESSED
0193  F6 C4 70          TEST   AH,CAPS_SHIFT+NUM_SHIFT+SCROLL_SHIFT ; SHIFT TOGGLE?
0196  74 05          JZ    K22B           ; GO IF NOT
0198  50          PUSH  AX             ; SAVE SCAN CODE AND SHIFT MASK
0199  E8 0439 R      CALL  SND_LED        ; GO TURN MODE INDICATORS ON
019C  58          POP   AX             ; RESTORE SCAN CODE
;
019D  3C 52          K22B: CMP    AL, INS_KEY   ; TEST FOR 1ST MAKE OF INSERT KEY
019F  75 41          JNE   K26            ; JUMP IF NOT INSERT KEY
01A1  B8 5200          MOV    AX,INS_KEY*256 ; SET SCAN CODE INTO AH, 0 INTO AL
01A4  E9 0375 R      JMP    K57            ; PUT INTO OUTPUT BUFFER
;
;----- BREAK SHIFT FOUND
01A7  80 FC 10          K23:  CMP    AH,SCROLL_SHIFT
01AA  73 1A          JAE   K24            ; IS THIS A TOGGLE KEY
01AC  F6 04          NOT   AH             ; YES, HANDLE BREAK TOGGLE
01AE  20 26 0017 R    AND   KB_FLAG,AH    ; INVERT MASK
01B2  3C 88          CMP    AL,ALT_KEY+80H
01B4  75 2C          JNE   K26            ; TURN OFF SHIFT BIT
;
;----- ALTERNATE SHIFT KEY RELEASED, GET THE VALUE INTO BUFFER
01B6  A0 0019 R      MOV    AL,ALT_INPUT  ; SCAN CODE OF 0
01B9  B4 00          MOV    AH,0          ; ZERO OUT THE FIELD
01BB  88 26 0019 R    MOV    ALT_INPUT,AH ; WAS THE INPUT 0
01BF  3C 00          CMP    AL,0          ; INTERRUPT_RETURN
01C1  74 1F          JE    K26            ; IT WASN'T, SO PUT IN BUFFER
01C3  E9 037E R      JMP    K58
;
01C6  F6 D4          K24:  NOT   AH             ; BREAK-TOGGLE
01C8  20 26 0018 R    AND   KB_FLAG_1,AH ; INVERT MASK
01CC  EB 14          JMP    SHORT K26     ; INDICATE NO LONGER DEPRESSED
;
;----- TEST FOR HOLD STATE
01CE  3C 80          K25:  CMP    AL,80H        ; NO-SHIFT-FOUND
01D0  73 10          JAE   K26            ; TEST FOR BREAK KEY
01D2  F6 06 0018 R 08   K25:  TEST   KB_FLAG_1,HOLD_STATE
01D7  74 1E          JZ    K28            ; NOTHING FOR BREAK CHARS FROM HERE ON
01D9  3C 45          CMP    AL,NUM_KEY   ; ARE WE IN HOLD STATE
01DB  74 05          JE    K26            ; BRANCH AROUND TEST IF NOT
01DD  80 26 0018 R F7   K25:  AND   KB_FLAG_1,NOT_HOLD_STATE ; CAN'T END HOLD ON NUM LOCK
;
01E2  FA          K26:  CLI     ; INTERRUPT_RETURN
01E3  B0 20          MOV    AL,E01        ; TURN OFF INTERRUPTS
01E5  E6 20          OUT   020H,AH        ; END OF INTERRUPT COMMAND
01E7  B0 AE          MOV    AL,ENA_KBD   ; SEND COMMAND TO INTERRUPT CONTROL PORT
01E9  E8 0498 R      CALL  SHIP_IT        ; INTERRUPT_RETURN=NO-E01
;
01EC  FA          K27:  CLI     ; INSURE KEYBOARD IS ENABLED
01ED  07          POP    ES             ; EXECUTE ENABLE
01EE  1F          POP    DS             ;
01EF  5F          POP    DI             ;
01F0  5E          POP    SI             ;
01F1  5A          POP    DX             ;
01F2  59          POP    CX             ;
01F3  5B          POP    BX             ;
01F4  58          POP    AX             ;
01F5  5D          POP    BP             ;
01F6  CF          IRET                  ; RETURN, INTERRUPTS BACK ON WITH FLAG CHANGE

```

```

;----- NOT IN HOLD STATE
01F7
01F7 F6 06 0017 R 08
01FC 75 03
01FE E9 0290 R

K28: TEST KB_FLAG,ALT_SHIFT ; NO-HOLD-STATE
      JNZ K29 ; ARE WE IN ALTERNATE SHIFT
      JMP K38 ; JUMP IF ALTERNATE SHIFT
      ; JUMP IF NOT ALTERNATE

;----- TEST FOR RESET KEY SEQUENCE (CTL ALT DEL)
0201
0201 F6 06 0017 R 04
0206 74 31
0208 3C 53
020A 75 2D

K29: TEST KB_FLAG,CTL_SHIFT ; TEST-RESET
      JZ K31 ; ARE WE IN CONTROL SHIFT ALSO
      CMP AL,DEL_KEY ; NO_RESET
      JNE K31 ; SHIFT STATE IS THERE, TEST KEY
      ; NO_RESET

;----- CTL-ALT-DEL HAS BEEN FOUND, DO I/O CLEANUP
020C C7 06 0072 R 1234
0212 E9 0000 E

MOV RESET_FLAG, 1234H ; SET FLAG FOR RESET FUNCTION
JMP START_1 ; JUMP TO POWER ON DIAGNOSTICS

;----- ALT-INPUT-TABLE
0215
0215 52 4F 50 51 4B 4C
4D
021C 47 48 49

K30 LABEL BYTE ; ALT-INPUT-TABLE
      DB 82,79,80,81,75,76,77
      ; 10 NUMBERS ON KEYPAD
      DB 71,72,73
;----- SUPER-SHIFT-TABLE
021F 10 11 12 13 14 15
0227 18 19 1E 1F 20 21
22 23
022F 24 25 26 2C 2D 2E
2F 30
0237 31 32

;----- IN ALTERNATE SHIFT, RESET NOT FOUND
0239
0239 3C 39
023B 75 05
023D B0 20
023F E9 0375 R

K31: CMP AL,57 ; NO-RESET
      JNE K32 ; TEST FOR SPACE KEY
      MOV AX,' ' ; NOT THERE
      JMP K57 ; SET SPACE CHAR
      ; BUFFER_FILL

;----- LOOK FOR KEY PAD ENTRY
0242
0242 BF 0215 R
0245 B9 000A
0248 F2/ AE
024A 75 12
024C 81 EF 0216 R
0250 A0 0019 R
0253 B4 0A
0255 F6 E4
0257 03 C7
0259 A2 0019 R
025C EB 84

K32: MOV DI,OFFSET K30 ; ALT-KEY-PAD
      MOV CX,10 ; ALT-INPUT-TABLE
      REPNE SCASB ; LOOK FOR ENTRY USING KEYPAD
      JNE K33 ; LOOK FOR MATCH
      SUB DI,OFFSET K30+1 ; NO ALT_KEY-PAD
      MOV AL,ALT_INPUT ; DI NOW HAS ENTRY VALUE
      MUL AH,10 ; GET THE CURRENT BYTE
      ADD AX,DI ; MULTIPLY BY 10
      MOV ALT_INPUT,AL ; ADD IN THE LATEST ENTRY
      JMP K26 ; STORE IT AWAY
      ; THROW AWAY THAT KEYSTROKE

;----- LOOK FOR SUPERSHIFT ENTRY
025E
025E C6 06 0019 R 00
0263 B9 001A
0266 F2/ AE
0268 75 05
026A B0 00
026C E9 0375 R

K33: MOV ALT_INPUT,0 ; NO-ALT-KEYPAD
      MOV CX,26 ; ZERO ANY PREVIOUS ENTRY INTO INPUT
      REPNE SCASB ; DI,ES ALREADY POINTING
      JNE K34 ; LOOK FOR MATCH IN ALPHABET
      MOV AL,0 ; NOT FOUND- FUNCTION KEY OR OTHER
      JMP K57 ; ASCII CODE OF ZERO
      ; PUT IT IN THE BUFFER

;----- LOOK FOR TOP ROW OF ALTERNATE SHIFT
026F
026F 3C 02
0271 72 0C
0273 3C 0E
0275 73 08
0277 80 C4 76
027A B0 00
027C E9 0375 R

K34: CMP AL,2 ; ALT-TOP-ROW
      JB K35 ; KEY WITH '1' ON IT
      CMP AL,14 ; NOT ONE OF INTERESTING KEYS
      JAE K35 ; IS IT IN THE REGION
      ADD AH,118 ; ALT-FUNCTION
      MOV AL,0 ; CONVERT PSEUDO SCAN CODE TO RANGE
      JMP K57 ; INDICATE AS SUCH
      ; BUFFER_FILL

;----- TRANSLATE ALTERNATE SHIFT PSEUDO SCAN CODES
027F
027F 3C 38
0281 73 03
0283
0283 E9 01E2 R
0286
0286 3C 47
0288 73 F9
028A B8 0000 E
028D E9 03CC R

K35: CMP AL,59 ; ALT-FUNCTION
      JAE K37 ; TEST FOR IN TABLE
      ; ALT-CONTINUE
      ; CLOSE-RETURN
      ; IGNORE THE KEY
      ; IN KEYPAD REGION
      ; IF SO, IGNORE
      ; ALT_SHIFT_PSEUDO_SCAN_TABLE
      ; TRANSLATE THAT

;----- NOT IN ALTERNATE SHIFT
0290
0290 F6 06 0017 R 04
0295 74 62

K38: TEST KB_FLAG,CTL_SHIFT ; NOT-ALT-SHIFT
      JZ K44 ; ARE WE IN CONTROL SHIFT
      ; NOT-CTL-SHIFT

;----- CONTROL SHIFT, TEST SPECIAL CHARACTERS
;----- TEST FOR BREAK AND PAUSE KEYS
0297 3C 46
0299 75 1D
029B 8B 1E 0080 R
029F 89 1E 001A R
02A3 89 1E 001C R
02A7 C6 06 0071 R 80

CMP AL,SCROLL_KEY ; TEST FOR BREAK
      JNE K39 ; NO-BREAK
      MOV BX,BUFFER_START ; RESET BUFFER TO EMPTY
      MOV BUFFER_HEAD,BX ;
      MOV BUFFER_TAIL,BX ;
      MOV BIOS_BREAK,80H ; TURN ON BIOS_BREAK BIT

;----- ENABLE KEYBOARD
02AC B0 AE
02AE E8 0498 R
02B1 CD 18
02B3 2B C0
02B5 E9 0375 R

MOV AL,ENA_KBD ; ENABLE KEYBOARD
CALL SHIP_IT ; EXECUTE ENABLE
INT 1BH ; BREAK INTERRUPT VECTOR
SUB AX,AX ; PUT OUT DUMMY CHARACTER
JMP K57 ; BUFFER_FILL

02B8
02B8 3C 45
02BA 75 26
02BC 80 0E 0018 R 08

CMP AL,NUM_KEY ; NO-BREAK
      JNE K41 ; LOOK FOR PAUSE KEY
      OR KB_FLAG_1,HOLD_STATE ; NO-PAUSE
      ; TURN ON THE HOLD FLAG

;----- ENABLE KEYBOARD
02C1 B0 AE
02C3 E8 0498 R
02C6 B0 20
02C8 E6 20

MOV AL,ENA_KBD ; ENABLE KEYBOARD
CALL SHIP_IT ; EXECUTE ENABLE
MOV AL,EDI ; END OF INTERRUPT TO CONTROL PORT
OUT 020H,AL ; ALLOW FURTHER KEYSTROKE INTS

```

```

;----- DURING PAUSE INTERVAL, TURN CRT BACK ON
02CA 80 3E 0049 R 07      CMP      CRT_MODE,7      ; IS THIS BLACK AND WHITE CARD
02CF 74 07                JE        K40             ; YES, NOTHING TO DO
02D1 BA 03D8              MOV      DX,03D8H        ; PORT FOR COLOR CARD
02D4 A0 0065 R           MOV      AL,CRT_MODE_SET ; GET THE VALUE OF THE CURRENT MODE
02D7 EE                  OUT      DX,AL           ; SET THE CRT MODE, SO THAT CRT IS ON
02D8                      ; PAUSE-LOOP

ENDIF

02D8                      K40A:
02DB F6 06 0018 R 08     TEST     KB_FLAG_1,OLD_STATE ; LOOP UNTIL FLAG TURNED OFF
02DD 75 F9                JNZ     K41              ; INTERRUPT_RETURN_NO_EOI
02DF E9 01EC R           JMP      K27A            ; NO-PAUSE
02E2                      K41:

;----- TEST SPECIAL CASE KEY 55
02E2 3C 37                CMP      AL,55           ; NOT-KEY-55
02E4 75 06                JNE     K42              ; NOT-KEY-55
02E6 B8 7200             MOV      AX,114*256     ; START/STOP PRINTING SWITCH
02E9 E9 0375 R           JMP      K57             ; BUFFER_FILL

;----- SET UP TO TRANSLATE CONTROL SHIFT
02EC                      K42:
02EC BB 0000 E           MOV      BX,OFFSET K8   ; NOT-KEY-55
02EF 3C 3B                CMP      AL,59          ; SET UP TO TRANSLATE CTL
02F1 72 7E                JB       K56             ; IS IT IN TABLE
                                ; YES, GO TRANSLATE CHAR
02F3 BB 0000 E           MOV      BX,OFFSET K9   ; CTL=TABLE-TRANSLATE
02F6 E9 03CC R           JMP      K63             ; CTL TABLE SCAN
                                ; TRANSLATE_SCAN

;----- NOT IN CONTROL SHIFT
02F9                      K44:
                                ; NOT-CTL-SHIFT

02F9 3C 47                CMP      AL,71          ; TEST FOR KEYPAD REGION
02FB 73 33                JAE     K48              ; HANDLE KEYPAD REGION
02FD F6 06 0017 R 03     TEST     KB_FLAG,LEFT_SHIFT+RIGHT_SHIFT
0302 74 62                JZ      K54              ; TEST FOR SHIFT STATE

;----- UPPER CASE, HANDLE SPECIAL CASES
0304 3C 0F                CMP      AL,15          ; BACK TAB KEY
0306 75 05                JNE     K45             ; NOT-BACK-TAB
0308 B8 0F00             MOV      AX,15*256     ; SET PSEUDO SCAN CODE
030B EB 68                JMP      SHORT K57       ; BUFFER_FILL

030D                      K45:
030D 3C 37                CMP      AL,55          ; NOT-BACK-TAB
030F 75 10                JNE     K46             ; PRINT SCREEN KEY
                                ; NOT-PRINT-SCREEN

;----- ISSUE INTERRUPT TO INDICATE PRINT SCREEN FUNCTION
0311 B0 AE                MOV      AL,ENA_KBD     ; INSURE KEYBOARD IS ENABLED
0313 E8 0498 R           CALL    SHIP_IT         ; EXECUTE ENABLE
0316 B0 20                MOV      AL,E0I         ; END OF CURRENT INTERRUPT
0318 E6 20                OUT     020H,AL         ; SO FURTHER THINGS CAN HAPPEN
031A 55                    BP      PUSH            ; SAVE POINTER
031B CD 05                INT     5H              ; ISSUE PRINT SCREEN INTERRUPT
031D 5D                    POP     BP               ; RESTORE POINTER
031E E9 01E7 R           JMP      K27             ; GO BACK WITHOUT EOI OCCURRING

0321                      K46:
0321 3C 3B                CMP      AL,59          ; NOT-PRINT-SCREEN
0323 72 06                JB       K47             ; FUNCTION KEYS
0325 BB 0000 E           MOV      BX,OFFSET K12  ; NOT-UPPER-FUNCTION
0328 E9 03CC R           JMP      K63             ; UPPER CASE PSEUDO SCAN CODES
                                ; TRANSLATE_SCAN

032B                      K47:
032B BB 0000 E           MOV      BX,OFFSET K11  ; NOT-UPPER-FUNCTION
032E EB 41                JMP      SHORT K56       ; POINT TO UPPER CASE TABLE
                                ; OK, TRANSLATE THE CHAR

;----- KEYPAD KEYS, MUST TEST NUM LOCK FOR DETERMINATION
0330                      K48:
0330 F6 06 0017 R 20     TEST     KB_FLAG,NUM_STATE ; KEYPAD-REGION
0335 75 21                JNZ     K52             ; ARE WE IN NUM LOCK
0337 F6 06 0017 R 03     TEST     KB_FLAG,LEFT_SHIFT+RIGHT_SHIFT ; TEST FOR SURE
033C 75 21                JNZ     K53             ; KEYPAD-REGION
                                ; ARE WE IN SHIFT STATE
                                ; IF SHIFTED, REALLY NUM STATE

;----- BASE CASE FOR KEYPAD
033E                      K49:
                                ; BASE-CASE
                                ;
033E 3C 4A                CMP      AL,74          ; SPECIAL CASE FOR A COUPLE OF KEYS
0340 74 0C                JE        K50            ; MINUS
0342 3C 4E                CMP      AL,78          ;
0344 74 0D                JE        K51            ;
0346 2C 47                SUB     AL,71           ; CONVERT ORIGIN
0348 BB 0000 E           MOV      BX,OFFSET K15  ; BASE CASE TABLE
034B E9 03CE R           JMP      K64            ; CONVERT TO PSEUDO SCAN

034E B8 4A2D             MOV      AX,74*256+'-' ; MINUS
0351 EB 22                JMP      SHORT K57       ; BUFFER_FILL

0353 B8 4E2B             MOV      AX,78*256+'+' ; PLUS
0356 EB 1D                JMP      SHORT K57       ; BUFFER_FILL

;----- MIGHT BE NUM LOCK, TEST SHIFT STATUS
0358                      K52:
0358 F6 06 0017 R 03     TEST     KB_FLAG,LEFT_SHIFT+RIGHT_SHIFT ; ALMOST-NUM-STATE
035D 75 DF                JNZ     K49             ; SHIFTED TEMP OUT OF NUM STATE

035F                      K53:
035F 2C 46                SUB     AL,70           ; REALLY NUM STATE
0361 BB 0000 E           MOV      BX,OFFSET K14  ; CONVERT ORIGIN
0364 EB 08                JMP      SHORT K56       ; NUM STATE TABLE
                                ; TRANSLATE_CHAR

;----- PLAIN OLD LOWER CASE
0366                      K54:
0366 3C 3B                CMP      AL,59          ; NOT-SHIFT
0368 72 04                JB       K55            ; TEST FOR FUNCTION KEYS
036A B0 00                MOV      AL,0           ; NOT-LOWER-FUNCTION
036C EB 07                JMP      SHORT K57       ; SCAN CODE IN AH ALREADY
                                ; BUFFER_FILL

036E                      K55:
036E BB 0000 E           MOV      BX,OFFSET K10  ; NOT-LOWER-FUNCTION
                                ; LC TABLE

;----- TRANSLATE THE CHARACTER

```

```

0371 FE C8      K56:          ; TRANSLATE-CHAR
0372 2E: D7      DEC AL          ; CONVERT ORIGIN
0373          XLAT CS:K11    ; CONVERT THE SCAN CODE TO ASCII

;----- PUT CHARACTER INTO BUFFER

0375          K57:          ; BUFFER-FILL
0375 3C FF      CMP AL,-1       ; IS THIS AN IGNORE CHAR
0377 74 1F      JE K59      ; YES, DO NOTHING WITH IT
0379 80 FC FF   CMP AH,-1       ; LOOK FOR -1 PSEUDO SCAN
037C 74 1A      JE K59      ; NEAR_INTERRUPT_RETURN

;----- HANDLE THE CAPS LOCK PROBLEM

037E          K58:          ; BUFFER-FILL-NOTEST
037E F6 06 0017 R 40 TEST KB_FLAG,CAPS_STATE ; ARE WE IN CAPS LOCK STATE
0383 74 20      JZ          ; SKIP IF NOT

;----- IN CAPS LOCK STATE

0385 F6 06 0017 R 03 TEST KB_FLAG,LEFT_SHIFT+RIGHT_SHIFT ; TEST FOR SHIFT STATE
038A 74 0F      JZ          ; IF NOT SHIFT, CONVERT LOWER TO UPPER

;----- CONVERT ANY UPPER CASE TO LOWER CASE

038C 3C 41      CMP AL,'A'       ; FIND OUT IF ALPHABETIC
038E 72 15      JB K61      ; NOT_CAPS_STATE
0390 3C 5A      CMP AL,'Z'       ; NOT_CAPS_STATE
0392 77 11      JA K61      ; NOT_CAPS_STATE
0394 04 20      ADD AL,'a'-'A'   ; CONVERT TO LOWER CASE
0396 EB 0D      JMP SHORT K61  ; NOT_CAPS_STATE

0398          K59:          ; NEAR_INTERRUPT_RETURN
0398 E9 01E2 R  JMP K26      ; INTERRUPT_RETURN

;----- CONVERT ANY LOWER CASE TO UPPER CASE

039B          K60:          ; LOWER-TO-UPPER
039B 3C 61      CMP AL,'a'       ; FIND OUT IF ALPHABETIC
039D 72 06      JB K61      ; NOT_CAPS_STATE
039F 3C 7A      CMP AL,'z'       ; NOT_CAPS_STATE
03A1 77 02      JA K61      ; NOT_CAPS_STATE
03A3 2C 20      SUB AL,'a'-'A'   ; CONVERT TO UPPER CASE

03A5          K61:          ; NOT-CAPS-STATE
03A5 8B 1E 001C R MOV BX,BUFFER_TAIL ; GET THE END POINTER TO THE BUFFER
03A9 8B F3      MOV SI,BX        ; SAVE THE VALUE
03AB EB 007F R  CALL KB          ; ADVANCE THE TAIL
03AC 3B 1E 001A R CMP BX,BUFFER_HEAD ; HAS THE BUFFER WRAPPED AROUND
03B2 74 22      JE K62      ; BUFFER_FULL_BEEP
03B4 89 04      MOV [SI],AX      ; STORE THE VALUE
03B6 89 1E 001C R MOV BF,BUFFER_TAIL,BX ; MOVE THE POINTER UP
03BA FA        CLI          ; TURN OFF INTERRUPTS
03BB 80 20      MOV AL,E01      ; END OF INTERRUPT COMMAND
03BD E6 20      OUT 020H,AL     ; SEND COMMAND TO INTERRUPT CONTROL PORT
03BF 80 AE      MOV AL,ENA_KBD  ; INSURE KEYBOARD IS ENABLED
03C1 E8 0498 R  CALL SHIP_IT    ; EXECUTE ENABLE
03C4 88 9102   MOV AX,09102H   ; MOVE IN POST CODE & TYPE
03C7 CD 15      INT 15H         ; PERFORM OTHER FUNCTION
03C9 E9 01E1 R  JMP K27A       ; INTERRUPT_RETURN

;----- TRANSLATE SCAN FOR PSEUDO SCAN CODES

03CC          K63:          ; TRANSLATE-SCAN
03CC 2C 3B      SUB AL,59        ; CONVERT ORIGIN TO FUNCTION KEYS
03CE 2E: D7      XLAT CS:K9      ; TRANSLATE-SCAN-ORGD
03D0 8A E0      MOV AH,AL        ; CTL TABLE SCAN
03D2 80 00      MOV AL,0         ; PUT VALUE INTO AH
03D4 EB 9F      MOV K57          ; ZERO ASCII CODE
03D6          KB_INT_1    ENDP      ; PUT IT INTO THE BUFFER

03D6          K62:          ; ENABLE INTR. CTL. CHIP
03D6 80 20      MOV AL,E01      ; NUMBER OF CYCLES FOR 1/8 SECOND TONE
03D8 E6 20      OUT INTA00,AL   ; GET CONTROL INFORMATION
03DA BB 0082    IN AX,KB_CTL    ; SAVE
03DD 50        PUSH AX         ; BEEP-CYCLE
03DE          K65:          ; TURN OFF TIMER GATE AND SPEAKER DATA
03DE 24 FC      AND AL,0FCH     ; IO DELAY
03E0 EB 00      JMP SHORT $+2   ; SPEAKER OFF
03E2 EB 00      AND AL,0FCH     ; SPEAKER OFF
03E4 E6 61      OUT KB_CTL,AL   ; TURN ON SPEAKER BIT
03E6 E6 61      OUT KB_CTL,AL   ; OUTPUT TO CONTROL
03E8 B9 00CE   MOV CX,0CEH     ; HALF CYCLE TIME FOR TONE
03EA E2 FE      LOOP K66        ; SPEAKER OFF
03EC 0C 02      OR AL,2         ; TURN ON SPEAKER BIT
03EE E6 61      OUT KB_CTL,AL   ; OUTPUT TO CONTROL
03F0 89 00E5   MOV CX,0E5H     ; SET UP COUNT
03F2 E2 FE      LOOP K67        ; ANOTHER HALF CYCLE
03F4 4B        DEC BX          ; TOTAL TIME COUNT
03F6 75 E9      JNZ K65         ; DO ANOTHER CYCLE
03F8 58        POP AX          ; RECOVER CONTROL
03FA E6 61      OUT KB_CTL,AL   ; OUTPUT THE CONTROL
03FB E9 01E7 R  JMP K27         ; EXIT

;-----
;
; SND_DATA
;
; THIS ROUTINES HANDLES TRANSMISSION OF COMMAND AND DATA BYTES
; TO THE KEYBOARD AND RECEIPT OF ACKNOWLEDGEMENTS. IT ALSO
; HANDLES ANY RETRIES IF REQUIRED
;-----

03FD          SND_DATA PROC NEAR
03FD 50        PUSH AX         ; SAVE REGISTERS
03FE 53        PUSH BX
03FF 51        PUSH CX
0400 8A F8      MOV BH,AL        ; SAVE TRANSMITTED BY FOR RETRIES
0402 B3 03      MOV BL,3         ; LOAD RETRY COUNT
0404 FA        CLI          ; DISABLE INTERRUPTS
0405 80 26 0097 R CF AND KB_FLAG_2,NOT (KB_FE+KB_FA) ; CLEAR ACK AND RESEND FLAGS

;----- WAIT FOR COMMAND TO ACCEPTED

040A          SD5:
040A 2B C9      SUB CX,CX        ;
040C          IN AL,STATUS_PORT ;
040C          TEST AL,INPT_BUF_FULL ;
0410 E0 FA      LOOPNZ SD5      ; WAIT FOR COMMAND TO BE ACCEPTED

;
0412 8A C7      MOV AL,BH        ; REESTABLISH BYTE TO TRANSMIT
0414 E6 60      OUT PORT_A,AL   ; SEND BYTE
0416 FB        STI          ; ENABLE INTERRUPTS
0417 B9 1A00    MOV CX,01A00H   ; LOAD COUNT FOR 10ms+

```

```

041A F6 06 0097 R 30
041F 75 0D
;
0421 E2 F7
;
0423 FE 0D
0425 75 0D
;
0427 80 0E 0097 R 80
042C EB 07
;
042E F6 06 0097 R 10
0433 74 EE
;
0435 59
0436 58
0437 58
0438 C3
0439
SD1: TEST KB_FLAG_2,KB_FE+KB_FA ; SEE IF EITHER BIT SET
      JNZ SD3 ; IF SET, SOMETHING RECEIVED GO PROCESS
;
; LOOP SD1 ; OTHERWISE WAIT
;
SD2: DEC BL ; DECREMENT RETRY COUNT
      JNZ SD0 ; RETRY TRANSMISSION
;
; OR KB_FLAG_2,KB_ERR ; RETURN ON TRANSMIT ERROR FLAG
      JMP SHORT SD4 ; RETRIES EXHAUSTED FORGET TRANSMISSION
;
SD3: TEST KB_FLAG_2,KB_FA ; SEE IF THIS IS AN ACKNOWLEDGE
      JZ ; IF NOT, GO RESEND
;
SD4: POP CX ; RESTORE REGISTERS
      POP BX
      POP AX ; *
      RET ; RETURN, GOOD TRANSMISSION
SND_DATA ENDP

```

SND_LED

THIS ROUTINES TURNS ON THE MODE INDICATORS.

```

0439
0439 FA
043A F6 06 0097 R 40
043F 75 47
;
0441 80 0E 0097 R 40
0446 80 20
0448 E6 20
044A EB 0D
;
044C
044C FA
044D F6 06 0097 R 40
0452 75 34
;
0454 80 0E 0097 R 40
0459 80 ED
045B E8 03FD R
045E FA
045F E8 048A R
0462 80 26 0097 R F8
0467 08 06 0097 R
046B F6 06 0097 R 80
0470 75 0B
;
0472 E8 03FD R
0475 FA
0476 F6 06 0097 R 80
047B 74 06
;
047D 80 F4
047F E8 03FD R
0482 FA
0483 80 26 0097 R 3F
;
048B FF
0489 C3
048A
SND_LED PROC NEAR
      CLI ; TURN OFF INTERRUPTS
      TEST KB_FLAG_2,KB_PR_LED ; CHECK FOR MODE INDICATOR UPDATE
      JNZ SL1 ; DONT UPDATE AGAIN IF UPDATE UNDERWAY
;
; OR KB_FLAG_2,KB_PR_LED ; TURN ON UPDATE IN PROCESS
      MOV AL,ED1 ; END OF INTERRUPT COMMAND
      OR 020H,AL ; SEND COMMAND TO INTERRUPT CONTROL PORT
      JMP SHORT SLO ; GO SEND MODE INDICATOR COMMAND
;
SND_LED1:
      CLI ; TURN OFF INTERRUPTS
      TEST KB_FLAG_2,KB_PR_LED ; CHECK FOR MODE INDICATOR UPDATE
      JNZ SL1 ; DONT UPDATE AGAIN IF UPDATE UNDERWAY
;
; OR KB_FLAG_2,KB_PR_LED ; TURN ON UPDATE IN PROCESS
      MOV AL,LED_CMD ; LED CMD BYTE
      CALL SND_DATA ; SEND DATA TO KEYBOARD
      CLI
      CALL MAKE_LED ; GO FORM INDICATOR DATA BYTE
      AND KB_FLAG_2,0F8H ; CLEAR MODE INDICATOR BITS
      OR KB_FLAG_2,AL ; SAVE PRESENT INDICATORS STATES FOR NEXT TIME
      TEST KB_FLAG_2,KB_ERR ; TRANSMIT ERROR DETECTED
      JNZ SL2 ; IF YES, BYPASS SECOND BYTE TRANSMISSION
;
      CALL SND_DATA ; SEND DATA TO KEYBOARD
      CLI ; TURN OFF INTERRUPTS
      TEST KB_FLAG_2,KB_ERR ; TRANSMIT ERROR DETECTED
      JZ SL3 ; IF NOT, DONT SEND AN ENABLE COMMAND
;
SL2: MOV AL,KB_ENABLE ; GET KEYBOARD CSA ENABLE COMMAND
      CALL SND_DATA ; SEND DATA TO KEYBOARD
      CLI ; TURN OFF INTERRUPTS
;
SL3: AND KB_FLAG_2,NOT(KB_PR_LED+KB_ERR) ; TURN OFF MODE INDICATOR
      ; UPDATE AND TRANSMIT ERROR FLAG
      ; ENABLE INTERRUPTS
      RET ; RETURN TO CALLER
SND_LED ENDP

```

MAKE_LED

THIS ROUTINES FORMS THE DATA BYTE NECESSARY TO TURN ON/OFF THE MODE INDICATORS

```

048A 51
048B A0 0017 R
048E 24 70
0490 B1 04
0492 D2 C0
0494 24 07
0496 59
0497 C3
0498
MAKE_LED PROC NEAR
      PUSH CX ; SAVE CX
      MOV AL,KB_FLAG ; GET CAPS & NUM LOCK INDICATORS
      AND AL,CAPS_STATE+NUM_STATE+SCROLL_STATE ; ISOLATE INDICATORS
      MOV CL,4 ; SHIFT COUNT
      ROL AL,CL ; SHIFT BITS OVER TO TURN ON INDICATORS
      AND AL,07H ; MAKE SURE ONLY MODE BITS ON
      POP CX
      RET ; RETURN TO CALLER
MAKE_LED ENDP

```

SHIP_IT

THIS ROUTINES HANDLES TRANSMISSION OF COMMAND AND DATA BYTES TO THE KEYBOARD CONTROLLER.

```

0498
0498 50
;
0499 FA
049A 2B C9
049C
049C E4 64
049E A8 02
04A0 E0 FA
;
04A2 58
04A3 E6 64
04A5 FB
04A6 C3
04A7
SHIP_IT PROC NEAR
      PUSH AX ; SAVE DATA TO SEND
;----- WAIT FOR COMMAND TO ACCEPTED
;
      CLI ; DISABLE INTERRUPTS
      SUB CX,CX ; CLEAR COUNTER
S10: IN AL,STATUS_PORT ;
      TEST AL,INPT_BUF_FULL ;
      LOOPNZ S10 ; WAIT FOR COMMAND TO BE ACCEPTED
;
      POP AX ; GET DATA TO SEND
      OUT STATUS_PORT,AL ; SEND TO KEYBOARD CONTROLLER
      STI ; ENABLE INTERRUPTS AGAIN
      RET ; RETURN TO CALLER
SHIP_IT ENDP
CODE ENDS
END

```



0000

TITLE 09/09/83 PRINT BIOS
LIST
INCLUDE SEGMENT.SRC
CODE SEGMENT BYTE PUBLIC

```

EXTRN DDS:NEAR
PUBLIC PRINTER_IO_1
INT 17
PRINTER_IO
THIS ROUTINE PROVIDES COMMUNICATION WITH THE PRINTER

(AH)=0 PRINT THE CHARACTER IN (AL)
ON RETURN, AH=1 IF CHARACTER COULD NOT BE PRINTED (TIME OUT)
OTHER BITS SET AS ON NORMAL STATUS CALL
(AH)=1 INITIALIZE THE PRINTER PORT
RETURNS WITH (AH) SET WITH PRINTER STATUS
(AH)=2 READ THE PRINTER STATUS INTO (AH)
7 6 5 4 3 2-1 0 TIME OUT
| | | | | | |
| | | | | | | UNUSED
| | | | | | | 1 = I/O ERROR
| | | | | | |
| | | | | | | 1 = SELECTED
| | | | | | | 1 = OUT OF PAPER
| | | | | | | 1 = ACKNOWLEDGE
| | | | | | | 1 = NOT BUSY

(DX) = PRINTER TO BE USED (0,1,2) CORRESPONDING TO ACTUAL VALUES
IN PRINTER_BASE AREA
DATA AREA PRINTER_BASE CONTAINS THE BASE ADDRESS OF THE PRINTER CARD(S)
AVAILABLE (LOCATED AT BEGINNING OF DATA SEGMENT, 408H ABSOLUTE, 3 WORDS)
DATA AREA PRINT_TIM_OUT (BYTE) MAY BE CHANGE TO CAUSE DIFFERENT
TIME OUT WAITS. DEFAULT=20 * 4

REGISTERS AH IS MODIFIED
ALL OTHERS UNCHANGED

```

```

ASSUME CS:CODE,DS:DATA

PRINTER_IO_1 PROC FAR ; ENTRY POINT FOR ORG 0EFD2H
STI ; INTERRUPTS BACK ON
PUSH DS ; SAVE SEGMENT
PUSH DX
PUSH SI
PUSH CX
PUSH BX
CALL DDS
MOV SI,DX ; GET PRINTER PARM
MOV BL,PRINT_TIM_OUT[SI] ; LOAD TIMEOUT VALUE
SHL SI,1 ; WORD OFFSET INTO TABLE
OR DX,DX ; GET BASE ADDRESS FOR PRINTER CARD
JZ B1 ; TEST DX FOR ZERO, INDICATING NO PRINT
OR AH,AH ; RETURN
JZ B2 ; TEST FOR (AH)=0
DEC AH ; PRINT AL
JZ B3 ; TEST FOR (AH)=1
DEC AH ; INIT_PRT
JZ B4 ; TEST FOR (AH)=2
JZ B5 ; PRINTER STATUS
RET

B1: POP BX ; RETURN
POP CX
POP SI ; RECOVER REGISTERS
POP DX
POP DS ; RECOVER REGISTERS
IRET

;----- PRINT THE CHARACTER IN (AL)
B2: PUSH AX ; SAVE VALUE TO PRINT
OUT DX,AL ; OUTPUT CHAR TO PORT
INC DX ; POINT TO STATUS PORT

;----- CHECK FOR PRINTER BUSY
PUSH BX ;
IN AL,DX ; GET STATUS
TEST AL,80H ; IS THE PRINTER CURRENTLY BUSY
JNZ B2_A ; OUT_STROBE

;----- INT 15 DEVICE BUSY
MOV AX,90FEH ; FUNCTION 90 PRINTER ID
INT 15H ;

;-----ADJUST OUTER LOOP COUNT
B2_A: SUB BH,BH ; CLEAR BH
RCL BX,1 ; MULT BY 4
RCL BX,1 ;
;-----WAIT BUSY
B3: SUB CX,CX ; INNER LOOP (64K)
B3_1: IN AL,DX ; GET STATUS
MOV AH,AL ; STATUS TO AH ALSO
TEST AL,80H ; IS THE PRINTER CURRENTLY BUSY
JNZ B4 ; OUT_STROBE
LOOP B3_1 ; LOOP IF NOT
DEC BX ; DROP OUTER LOOP COUNT -----
JNZ B3 ; MAKE ANOTHER PASS IF NOT ZERO

POP BX ; RESTORE BX -----
OR AH,1 ; SET ERROR FLAG
AND AH,09FH ; TURN OFF THE UNUSED BITS
JMP SHORT B7 ; RETURN WITH ERROR FLAG SET
POP BX ; RESTORE BX -----
;-----
; OUT_STROBE
; SET THE STROBE HIGH

MOV AL,0DH ;
INC DX ;
OUT DX,AL ; SET THE STROBE LOW
MOV AL,0CH ; IO DELAY
JMP SHORT $+2 ;
OUT DX,AL ;
POP AX ; RECOVER THE OUTPUT CHAR

;----- PRINTER STATUS
B5:
B6: PUSH AX ; SAVE AL REG
MOV DX,PRINTER_BASE[SI]

```

0000 PRINTER_IO_1 PROC FAR ; ENTRY POINT FOR ORG 0EFD2H
0000 FB STI ; INTERRUPTS BACK ON
0001 1E PUSH DS ; SAVE SEGMENT
0002 52 PUSH DX
0003 56 PUSH SI
0004 51 PUSH CX
0005 53 PUSH BX
0006 E8 0000 E CALL DDS
0009 8B F2 MOV SI,DX ; GET PRINTER PARM
0008 8A 9C 0078 R MOV BL,PRINT_TIM_OUT[SI] ; LOAD TIMEOUT VALUE
000F D1 E6 SHL SI,1 ; WORD OFFSET INTO TABLE
0011 8B 94 0008 R OR DX,DX ; GET BASE ADDRESS FOR PRINTER CARD
0015 08 D2 JZ B1 ; TEST DX FOR ZERO, INDICATING NO PRINT
0017 74 DC OR AH,AH ; RETURN
0019 0A E4 JZ B2 ; TEST FOR (AH)=0
001B 74 0E DEC AH ; PRINT AL
001D FE CC JZ B3 ; TEST FOR (AH)=1
001F 74 54 DEC AH ; INIT_PRT
0021 FE CC JZ B4 ; TEST FOR (AH)=2
0023 74 3C JZ B5 ; PRINTER STATUS
0025 RET
0025 5B B1: POP BX ; RETURN
0026 59 POP CX
0027 5E POP SI ; RECOVER REGISTERS
0028 5A POP DX ; RECOVER REGISTERS
0029 1F POP DS
002A CF IRET

002B ;----- PRINT THE CHARACTER IN (AL)
002B 50 B2: PUSH AX ; SAVE VALUE TO PRINT
002C EE OUT DX,AL ; OUTPUT CHAR TO PORT
002D 42 INC DX ; POINT TO STATUS PORT
;----- CHECK FOR PRINTER BUSY
002E 53 PUSH BX ;
002F EC IN AL,DX ; GET STATUS
0030 A8 80 TEST AL,80H ; IS THE PRINTER CURRENTLY BUSY
0032 75 05 JNZ B2_A ; OUT_STROBE

0034 B8 90FE ;----- INT 15 DEVICE BUSY
0037 CD 15 MOV AX,90FEH ; FUNCTION 90 PRINTER ID
INT 15H ;

0039 ;-----ADJUST OUTER LOOP COUNT
0039 2A FF B2_A: SUB BH,BH ; CLEAR BH
003B D1 D3 RCL BX,1 ; MULT BY 4
003D D1 D3 RCL BX,1 ;

003F 2B C9 ;-----WAIT BUSY
0041 EC B3: SUB CX,CX ; INNER LOOP (64K)
0042 8A E0 B3_1: IN AL,DX ; GET STATUS
0044 A8 80 MOV AH,AL ; STATUS TO AH ALSO
0046 75 0E TEST AL,80H ; IS THE PRINTER CURRENTLY BUSY
0048 E2 F7 JNZ B4 ; OUT_STROBE
004A 4B LOOP B3_1 ; LOOP IF NOT
004B 75 F2 DEC BX ; DROP OUTER LOOP COUNT -----
004D 5B JNZ B3 ; MAKE ANOTHER PASS IF NOT ZERO
POP BX ; RESTORE BX -----
004E 80 CC 01 OR AH,1 ; SET ERROR FLAG
0051 80 E4 F9 AND AH,09FH ; TURN OFF THE UNUSED BITS
0054 E8 17 JMP SHORT B7 ; RETURN WITH ERROR FLAG SET
0056 5B POP BX ; RESTORE BX -----
;-----
0057 80 OD ; OUT_STROBE
0059 42 ; SET THE STROBE HIGH
MOV AL,0DH ;
INC DX ;
005A EE OUT DX,AL ; SET THE STROBE LOW
005B 80 OD MOV AL,0CH ; IO DELAY
005D EB 00 JMP SHORT \$+2 ;
005F EE OUT DX,AL ;
0060 58 POP AX ; RECOVER THE OUTPUT CHAR

0061 ;----- PRINTER STATUS
0061 50 B5:
0062 B6: PUSH AX ; SAVE AL REG
0062 8B 94 0008 R MOV DX,PRINTER_BASE[SI]

SECTION 5

```

0066 42          INC     DX
0067 EC          IN      AL,DX          ; GET PRINTER STATUS
0068 8A E0       MOV     AH,AL
006A 80 E4 F8    AND     AH,0F8H          ; TURN OFF UNUSED BITS
0069             ; STATUS SET
006D 5A          POP     DX          ; RECOVER AL REG
006E 8A C2       MOV     AL,DL          ; GET CHARACTER INTO AL
0070 80 F4 48    XOR     AH,48H          ; FLIP A COUPLE OF BITS
0073 EB B0       JMP     B1          ; RETURN FROM ROUTINE

;----- INITIALIZE THE PRINTER PORT

0075             B8:
0075 50          PUSH    AX          ; SAVE AL
0076 42          INC     DX          ; POINT TO OUTPUT PORT
0077 42          INC     DX
0078 B0 08       MOV     AL,8          ; SET INIT LINE LOW
007A EE          OUT     DX,AL
007B BB OFA0    MOV     AX,1000*4
007E             ; -----
007E 48          DEC     AX          ; INIT_LOOP
007F 75 FD       JNZ    B9          ; LOOP FOR RESET TO TAKE
0081 B0 0C       MOV     AL,0CH          ; INIT_LOOP
0083 EE          OUT     DX,AL          ; NO INTERRUPTS, NON AUTO LF, INIT HIGH
0084 EB DC       JMP     B6          ; PRT_STATUS_1
0086             PRINTER_IO_1
0086             CODE
0086             ENDS
0086             END

```

0000

TITLE DATE 07/06/83 RS232
.LIST
C INCLUDE SEGMENT SRC
C CODE SEGMENT BYTE PUBLIC
C

EXTRN DDS:NEAR
EXTRN A1:NEAR
PUBLIC RS232_IO_1

;RS232_IO_1
THIS ROUTINE PROVIDES BYTE STREAM I/O TO THE COMMUNICATIONS
PORT ACCORDING TO THE PARAMETERS:
(AH)=0 INITIALIZE THE COMMUNICATIONS PORT
(AL) HAS PARMS FOR INITIALIZATION
7 6 5 4 3 2 1 0
---- BAUD RATE -- PARITY-- STOPBIT 1 --WORD LENGTH--
000 - 110 X0 = NONE 0 - 1 10 - 7 BITS
001 - 150 01 = ODD 1 - 2 11 - 8 BITS
010 - 300 11 = EVEN
011 - 600
100 - 1200
101 - 2400
110 - 4800
111 - 9600
(AH)=1 ON RETURN CONDITIONS SET AS IN CALL TO COMMO STATUS (AH=3)
SEND THE CHARACTER IN (AL) OVER THE COMMO LINE
(AL) REGISTER IS PRESERVED
ON EXIT, BIT 7 OF AH IS SET IF THE ROUTINE WAS UNABLE TO
TRANSMIT THE BYTE OF DATA OVER THE LINE.
IF BIT 7 OF AH IS NOT SET, THE
REMAINDER OF AH IS SET AS IN A STATUS REQUEST,
REFLECTING THE CURRENT STATUS OF THE LINE.
(AH)=2 RECEIVE A CHARACTER IN (AL) FROM COMMO LINE BEFORE
RETURNING TO CALLER
ON EXIT, AH HAS THE CURRENT LINE STATUS, AS SET BY THE
STATUS ROUTINE, EXCEPT THAT THE ONLY BITS
LEFT ON ARE THE ERROR BITS (7,4,3,2,1)
IF AH HAS BIT 7 ON (TIME OUT) THE REMAINING
BITS ARE NOT PREDICTABLE.
THUS, AH IS NON ZERO ONLY WHEN AN ERROR OCCURRED.
(AH)=3 RETURN THE COMMO PORT STATUS IN (AX)
AH CONTAINS THE LINE CONTROL STATUS
BIT 7 = TIME OUT
BIT 6 = TRANS SHIFT REGISTER EMPTY
BIT 5 = TRAN HOLDING REGISTER EMPTY
BIT 4 = BREAK DETECT
BIT 3 = FRAMING ERROR
BIT 2 = PARITY ERROR
BIT 1 = OVERRUN ERROR
BIT 0 = DATA READY
AL CONTAINS THE MODEM STATUS
BIT 7 = RECEIVED LINE SIGNAL DETECT
BIT 6 = RING INDICATOR
BIT 5 = DATA SET READY
BIT 4 = CLEAR TO SEND
BIT 3 = DELTA RECEIVE LINE SIGNAL DETECT
BIT 2 = TRAILING EDGE RING DETECTOR
BIT 1 = DELTA DATA SET READY
BIT 0 = DELTA CLEAR TO SEND
(DX) = PARAMETER INDICATING WHICH RS232 CARD (0,1 ALLOWED)
DATA AREA RS232_BASE CONTAINS THE BASE ADDRESS OF THE 8250 ON THE CARD
LOCATION 400H CONTAINS UP TO 4 RS232 ADDRESSES POSSIBLE
DATA AREA LABEL RS232_TIM_OUT (BYTE) CONTAINS OUTER LOOP COUNT
VALUE FOR TIMEOUT (DEFAULT=1)
;OUTPUT
AX MODIFIED ACCORDING TO PARMS OF CALL
ALL OTHERS UNCHANGED
ASSUME CS:CODE,DS:DATA

0000

RS232_IO_1 PROC FAR
;----- VECTOR TO APPROPRIATE ROUTINE

0000 FB STI ; INTERRUPTS BACK ON
0001 1E PUSH DS ; SAVE SEGMENT
0002 52 PUSH DX
0003 56 PUSH SI
0004 57 PUSH DI
0005 51 PUSH CX
0006 53 PUSH BX
0007 8B F2 MOV SI,DX ; RS232 VALUE TO SI
0009 8B FA MOV DI,DX ; AND TO DI (FOR TIMEOUTS)
000B D1 EG SHL SI,1 ; WORD OFFSET
000D E8 0000 E CALL DDS
0010 8B 94 0000 R MOV DX,RS232_BASE[SI] ; GET BASE ADDRESS
0014 0B D2 OR DX,DX ; TEST FOR 0 BASE ADDRESS
0016 74 13 JZ A3 ; RETURN
0018 0A E4 OR AH,AH ; TEST FOR (AH)=0
001A 74 16 JZ A4 ; COMMUN INIT
001C FE CC DEC AH ; TEST FOR (AH)=1
001E 74 4B JZ A5 ; SEND AL
0020 FE CC DEC AH ; TEST FOR (AH)=2
0022 74 70 JZ A2 ; RECEIVE INTO AL
0024 FE CC DEC AH ; TEST FOR (AH)=3
0026 75 03 JNZ A3
0028 E9 00B6 R JMP A18 ; COMMUNICATION STATUS
002B 5B POP BX ; RETURN FROM RS232
002C 59 POP CX
002D 5F POP DI
002E 5E POP SI
002F 5A POP DX
0030 1F POP DS
0031 CF IRET ; RETURN TO CALLER, NO ACTION

0032 AH: MOV AH,AL ; SAVE INIT PARMS IN AH
0034 83 C2 03 ADD DX,3 ; POINT TO 8250 CONTROL REGISTER
0037 B0 B0 MOV AL,B0H
0039 EE OUT DX,AL ; SET DLAB=1

;----- DETERMINE BAUD RATE DIVISOR
003A 8A D4 MOV DL,AH ; GET PARMS TO DL
003C B1 D0 MOV CL,4
003E D2 C2 ROL DL,CL
0040 81 E2 000E AND DX,0EH ; ISOLATE THEM

SECTION 5

```

0044 BF 0000 E      MOV     D1,OFFSET A1      ; BASE OF TABLE
0047 03 FA          ADD     D1,DX             ; PUT INTO INDEX REGISTER
0049 8B 94 0000 R   MOV     DX,RS232_BASE[S1] ; POINT TO HIGH ORDER OF DIVISOR
004D 42             INC     DX
004E 2E: 8A 45 01  MOV     AL,CS:[D1]+1     ; GET HIGH ORDER OF DIVISOR
0052 EE           OUT     DX,AL            ; SET MS OF DIV TO 0
0053 4A           DEC     DX
0054 EB 00         JMP     SHORT S+2        ; 10 DELAY
0056 2E: 8A 05     MOV     AL,CS:[D1]      ; GET LOW ORDER OF DIVISOR
0059 EE           OUT     DX,AL            ; SET LOW OF DIVISOR
005A 83 C2 03     ADD     DX,3
005D 8A C4        MOV     AL,AH            ; GET PARMS BACK
005F 24 1F       AND     AL,01FH         ; STRIP OFF THE BAUD BITS
0061 EE           OUT     DX,AL            ; LINE CONTROL TO 8 BITS
0062 4A           DEC     DX
0063 4A           DEC     DX
0064 EB 00         JMP     SHORT S+2        ; 10 DELAY
0066 B0 00        MOV     AL,0            ; INTERRUPT ENABLES ALL OFF
0068 EE           OUT     DX,AL            ; COM STATUS
0069 EB 4B

;----- SEND CHARACTER IN (AL) OVER COMMO LINE

006B             A5:      PUSH   AX                ; SAVE CHAR TO SEND
006C 83 C2 04     ADD     DX,4            ; MODEM CONTROL REGISTER
006F B0 03        MOV     AL,3            ; DTR AND RTS
0071 EE           OUT     DX,AL            ; DATA TERMINAL READY, REQUEST TO SEND
0072 42           INC     DX                ; MODEM STATUS REGISTER
0073 42           INC     DX
0074 B7 30        MOV     BH,30H          ; DATA SET READY & CLEAR TO SEND
0076 EB 00C5 R   CALL   WAIT_FOR_STATUS  ; ARE BOTH TRUE
0079 74 08        JZ     A9                ; YES, READY TO TRANSMIT CHAR
007B             A7:      POP    CX                ; RELOAD DATA BYTE
007C 8A C1        MOV     AL,CL
007E             A8:      OR     AH,80H           ; INDICATE TIME OUT
0081 EB A8        JMP     A3                ; RETURN

0083             A9:      DEC     DX                ; CLEAR TO SEND
0084             A10:     MOV     BH,20H          ; LINE STATUS REGISTER
0086 EB 00C5 R   CALL   WAIT_FOR_STATUS  ; WAIT SEND
0089 75 F0        JNZ    A7                ; IS TRANSMITTER READY
008B             A11:     SUB     DX,5            ; TEST FOR TRANSMITTER READY
008E 59           POP     CX                ; RETURN WITH TIME OUT SET
008F 8A C1        MOV     AL,CL           ; DATA PORT
0091 EE           OUT     DX,AL            ; RECOVER IN CX TEMPORARILY
0092 EB 97        JMP     A3                ; MOVE CHAR TO AL FOR OUT, STATUS IN AH
                                ; OUTPUT CHARACTER
                                ; RETURN

;----- RECEIVE CHARACTER FROM COMMO LINE

0094             A12:     ADD     DX,4            ; MODEM CONTROL REGISTER
0097 B0 01        MOV     AL,1            ; DATA TERMINAL READY
0099 EE           OUT     DX,AL            ; DATA TERMINAL READY
009A 42           INC     DX                ; MODEM STATUS REGISTER
009B 42           INC     DX
009C             A13:     MOV     BH,20H          ; WAIT_DSR
009E EB 00C5 R   CALL   WAIT_FOR_STATUS  ; DATA SET READY
00A1 75 0B        JNZ    A15               ; TEST FOR DSR
00A3             A15:     DEC     DX                ; RETURN WITH ERROR
00A4             A16:     MOV     BH,1            ; WAIT_DSR END
00A6 EB 00C5 R   CALL   WAIT_FOR_STATUS  ; LINE STATUS REGISTER
00A9 75 03        JNZ    A17               ; WAIT_RECV
00AB             A17:     AND     AH,0011110B    ; RECEIVE BUFFER FULL
00AE 8B 94 0000 R MOV     DX,RS232_BASE[S1] ; TEST FOR REC. BUFF. FULL
00B2 EC           IN     AL,DX            ; SET TIME OUT ERROR
00B3 E9 002B R   JMP     A3                ; GET CHAR
                                ; TEST FOR ERROR CONDITIONS ON RECVD CHAR
                                ; DATA PORT
                                ; GET CHARACTER FROM LINE
                                ; RETURN

;----- COMMO PORT STATUS ROUTINE

00B6             A18:     MOV     DX,RS232_BASE[S1] ; CONTROL PORT
00B8 83 C2 05     ADD     DX,5            ; SAVE BX -----
00BD EC           IN     AL,DX            ; GET LINE CONTROL STATUS
00BE 8A E0        MOV     AH,AL           ; PUT IN AH FOR RETURN
00C0 42           INC     DX                ; POINT TO MODEM STATUS REGISTER
00C1 EC           IN     AL,DX            ; GET MODEM CONTROL STATUS
00C2 E9 002B R   JMP     A3                ; RETURN

;-----
; ENTRY: BH=STATUS BIT(S) TO LOOK FOR,
;        DX=ADDR. OF STATUS REG
; EXIT:  ZERO FLAG ON = STATUS FOUND
;        ZERO FLAG OFF = TIMEOUT.
;        AH=LAST STATUS READ
;-----
00C5             WAIT_FOR_STATUS PROC NEAR
00C5 8A 9D 007C R MOV     BL,RS232_TIM_OUT[D1] ; LOAD OUTER LOOP COUNT

;-----ADJUST OUTER LOOP COUNT
;-----
00C9 55           PUSH   BP                ; SAVE BP -----
00CA 53           PUSH   BX                ; SAVE BX -----
00CB 5D           POP    BP                ; USE BP FOR OUTER LOOP COUNT
00CC 81 E5 00FF  AND     BP,00FFH        ; STRIP HIGH BITS
00DD 01 D5       RCL    BP,1              ; MULT OUTER BY 4
00DE 01 D5       RCL    BP,1

00D4 2B C9       WFS0: SUB     CX,CX            ; GET STATUS
00D6 EC         WFS1: IN     AL,DX            ; MOVE TO AH
00D7 8A E0        MOV     AH,AL           ; MOVE TO AH
00D9 22 C7       AND     AL,BH            ; ISOLATE BITS TO TEST
00DB 3A C7       CMP     AH,BH            ; EXACTLY = TO MASK
00DD 74 07       JE     WFS_END          ; RETURN WITH ZERO FLAG ON
00DF E2 F5       LOOP  WFS1              ; TRY AGAIN
00E1 4D         DEC     BP                ; -----
00E2 75 F0       JNZ    WFS0             ; -----
00E4 0A FF       OR     BH,BH            ; SET ZERO FLAG OFF
00E6             WFS_END: POP     BP                ; RESTORE BP -----
00E6 5D           PUSH   BP
00E7 C3         RET                     ;
00E8             WAIT_FOR_STATUS ENDP
RS232_10_1     ENDP

00E8             CODE     ENDS

```

TITLE 08/18/83 VIDEO1
.LIST

includes are postequ.src, dseg.src

0000

C INCLUDE SEGMENT.SRC
C CODE SEGMENT BYTE PUBLIC
C

EXTRN DDS:NEAR
EXTRN M5:WORD
EXTRN M6:BYTE
EXTRN M7:BYTE
EXTRN CRT_CHAR_GEN:NEAR
EXTRN BEEP:NEAR

= 0010

PUBLIC VIDEO_01_1
M4 EQU_0010H ;

INT 10
VIDEO_01

THESE ROUTINES PROVIDE THE CRT INTERFACE
THE FOLLOWING FUNCTIONS ARE PROVIDED:
(AH)=0 SET MODE (AL) CONTAINS MODE VALUE
(AL)=0 40X25 BW (POWER ON DEFAULT)
(AL)=1 40X25 COLOR
(AL)=2 80X25 BW
(AL)=3 80X25 COLOR
GRAPHICS MODES
(AL)=4 320X200 COLOR
(AL)=5 320X200 BW
(AL)=6 640X200 BW
CRT MODE: = 7 80X25 B&W CARD (USED INTERNAL TO VIDEO ONLY)
*** NOTES - BW MODES OPERATE SAME AS COLOR MODES, BUT COLOR
BURST IS NOT ENABLED
-CURSOR IS NOT DISPLAYED IN GRAPHICS MODE
(AH)=1 SET CURSOR TYPE
(CH) = BITS 4-0 = START LINE FOR CURSOR
** HARDWARE WILL ALWAYS CAUSE BLINK
** SETTING BIT 5 OR 6 WILL CAUSE ERRATIC BLINKING
OR NO CURSOR AT ALL
(CL) = BITS 4-0 = END LINE FOR CURSOR
(AH)=2 SET CURSOR POSITION
(DH,DL) = ROW,COLUMN (0,0) IS UPPER LEFT
(BH) = PAGE NUMBER (MUST BE 0 FOR GRAPHICS MODES)
(AH)=3 READ CURSOR POSITION
(BH) = PAGE NUMBER (MUST BE 0 FOR GRAPHICS MODES)
ON EXIT (DH,DL) = ROW,COLUMN OF CURRENT CURSOR
(CH,CL) = CURSOR MODE CURRENTLY SET
(AH)=4 READ LIGHT PEN POSITION
ON EXIT:
(AH) = 0 -- LIGHT PEN SWITCH NOT DOWN/NOT TRIGGERED
(AH) = 1 -- VALID LIGHT PEN VALUE IN REGISTERS
(DH,DL) = ROW,COLUMN OF CHARACTER LP POSN
(CH) = RASTER LINE (0-199)
(BX) = PIXEL COLUMN (0-319,639)
(AH)=5 SELECT ACTIVE DISPLAY PAGE (VALID ONLY FOR ALPHA MODES)
(AL)=NEW PAGE VALUE (0-7 FOR MODES 0&1, 0-3 FOR MODES 2&3)
(AH)=6 SCROLL ACTIVE PAGE UP
(AL) = NUMBER OF LINES, INPUT LINES BLANKED AT BOTTOM OF WINDOW
AL = 0 MEANS BLANK ENTIRE WINDOW
(CH,CL) = ROW,COLUMN OF UPPER LEFT CORNER OF SCROLL
(DH,DL) = ROW,COLUMN OF LOWER RIGHT CORNER OF SCROLL
(BH) = ATTRIBUTE TO BE USED ON BLANK LINE
(AH)=7 SCROLL ACTIVE PAGE DOWN
(AL) = NUMBER OF LINES, INPUT LINES BLANKED AT TOP OF WINDOW
AL = 0 MEANS BLANK ENTIRE WINDOW
(CH,CL) = ROW,COLUMN OF UPPER LEFT CORNER OF SCROLL
(DH,DL) = ROW,COLUMN OF LOWER RIGHT CORNER OF SCROLL
(BH) = ATTRIBUTE TO BE USED ON BLANK LINE

CHARACTER HANDLING ROUTINES
(AH) = 8 READ ATTRIBUTE/CHARACTER AT CURRENT CURSOR POSITION
(BH) = DISPLAY PAGE (VALID FOR ALPHA MODES ONLY)
ON EXIT:
(AL) = CHAR READ
(AH) = ATTRIBUTE OF CHARACTER READ (ALPHA MODES ONLY)
(AH) = 9 WRITE ATTRIBUTE/CHARACTER AT CURRENT CURSOR POSITION
(BH) = DISPLAY PAGE (VALID FOR ALPHA MODES ONLY)
(CX) = COUNT OF CHARACTERS TO WRITE
(AL) = CHAR TO WRITE
(BL) = ATTRIBUTE OF CHARACTER (ALPHA)/COLOR OF CHAR (GRAPHICS)
SEE NOTE ON WRITE DOT FOR BIT 7 OF BL = 1
(AH) = 10 WRITE CHARACTER ONLY AT CURRENT CURSOR POSITION
(BH) = DISPLAY PAGE (VALID FOR ALPHA MODES ONLY)
(CX) = COUNT OF CHARACTERS TO WRITE
(AL) = CHAR TO WRITE
FOR READ/WRITE CHARACTER INTERFACE WHILE IN GRAPHICS MODE, THE
CHARACTERS ARE FORMED FROM A CHARACTER GENERATOR IMAGE
MAINTAINED IN THE SYSTEM ROM. ONLY THE 1ST 128 CHARS
ARE CONTAINED THERE. TO READ/WRITE THE SECOND 128 CHARS,
THE USER MUST INITIALIZE THE POINTER AT INTERRUPT 1FH
(LOCATION 00070H) TO POINT TO THE 1K BYTE TABLE CONTAINING
THE CODE POINTS FOR THE SECOND 128 CHARS (128-255).
FOR WRITE CHARACTER INTERFACE IN GRAPHICS MODE, THE REPLICATION FACTOR
CONTAINED IN (CX) ON ENTRY WILL PRODUCE VALID RESULTS ONLY
FOR CHARACTERS CONTAINED ON THE SAME ROW. CONTINUATION TO
SUCCEEDING LINES WILL NOT PRODUCE CORRECTLY.

GRAPHICS INTERFACE
(AH) = 11 SET COLOR PALETTE
(BH) = PALLETTE COLOR ID BEING SET (0-127)
(BL) = COLOR VALUE TO BE USED WITH THAT COLOR ID
NOTE: FOR THE CURRENT COLOR CARD, THIS ENTRY POINT HAS
MEANING ONLY FOR 320X200 GRAPHICS.
COLOR ID = 0 SELECTS THE BACKGROUND COLOR (0-15)
COLOR ID = 1 SELECTS THE PALLETTE TO BE USED:
0 = GREEN(1)/RED(2)/YELLOW(3)
1 = CYAN(1)/MAGENTA(2)/WHITE(3)
IN 40X25 OR 80X25 ALPHA MODES, THE VALUE SET FOR
PALLETTE COLOR 0 INDICATES THE BORDER COLOR
TO BE USED (VALUES 0-31, WHERE 16-31 SELECT THE
HIGH INTENSITY BACKGROUND SET.
(AH) = 12 WRITE DOT
(DX) = ROW NUMBER
(CX) = COLUMN NUMBER
(AL) = COLOR VALUE
IF BIT 7 OF AL = 1, THEN THE COLOR VALUE IS EXCLUSIVE
OR'D WITH THE CURRENT CONTENTS OF THE DOT
(AH) = 13 READ DOT
(DX) = ROW NUMBER
(CX) = COLUMN NUMBER
(AL) RETURNS THE DOT READ

```

.....
ASCI1 TELETYPE ROUTINE FOR OUTPUT
.....
(AH) = 14 WRITE TELETYPE TO ACTIVE PAGE
      (AL) = CHAR TO WRITE
      (BL) = FOREGROUND COLOR IN GRAPHICS MODE
      NOTE -- SCREEN WIDTH IS CONTROLLED BY PREVIOUS MODE SET

(AH) = 15 CURRENT VIDEO STATE
      RETURNS THE CURRENT VIDEO STATE
      (AL) = MODE CURRENTLY SET ( SEE AH=0 FOR EXPLANATION)
      (AH) = NUMBER OF CHARACTER COLUMNS ON SCREEN
      (BH) = CURRENT ACTIVE DISPLAY PAGE

(AH) = 16 RESERVED
(AH) = 17 RESERVED
(AH) = 18 RESERVED

(AH) = 19 WRITE STRING
      ES:BP - POINTER TO STRING TO BE WRITTEN
      CX   - LENGTH OF CHARACTER STRING TO WRITTEN
      DX   - CURSOR POSITION FOR STRING TO BE WRITTEN
      BH   - PAGE NUMBER

(AL) = 0
      BL - ATTRIBUTE
      STRING IS [CHAR,CHAR, ... ,CHAR]
      CURSOR NOT MOVED

(AL) = 1
      BL - ATTRIBUTE
      STRING IS [CHAR,CHAR, ... ,CHAR]
      CURSOR IS MOVED

(AL) = 2
      STRING IS [CHAR,ATTR,CHAR,ATTR .. ,CHAR,ATTR]
      CURSOR IS NOT MOVED

(AL) = 3
      STRING IS [CHAR,ATTR,CHAR,ATTR .. ,CHAR,ATTR]
      CURSOR IS MOVED

NOTE: CARRIAGE RETURN, LINE FEED, BACKSPACE, AND BELL ARE
      TREATED AS COMMANDS RATHER THAN PRINTABLE CHARACTERS.

SS,SP,ES,DS,CX,BX,SI,DI,BP PRESERVED DURING CALL
ALL OTHERS DESTROYED.
-----
ASSUME CS:CODE,DS:DATA,ES:VIDEO_RAM
.....

```

```

PUBLIC SET_MODE
PUBLIC SET_CPOS
PUBLIC READ_CURSOR
PUBLIC READ_LPEN
PUBLIC ACT_DISP_PAGE
PUBLIC SCROLL_UP
PUBLIC SCROLL_DOWN
PUBLIC READ_AC_CURRENT
PUBLIC WRITE_AC_CURRENT
PUBLIC WRITE_C_CURRENT
PUBLIC SET_COLOR
PUBLIC WRITE_DOT
PUBLIC READ_DOT
PUBLIC WRITE_TTY
PUBLIC VIDEO_STATE
M1 LABEL WORD ; TABLE OF ROUTINES WITHIN VIDEO I/O
0000 0071 R DW OFFSET SET_MODE
0002 0140 R DW OFFSET SET_CTYPE
0004 0174 R DW OFFSET SET_CPOS
0006 019E R DW OFFSET READ_CURSOR
0008 07DF R DW OFFSET READ_LPEN
000A 0195 R DW OFFSET ACT_DISP_PAGE
000C 0222 R DW OFFSET SCROLL_UP
000E 02C6 R DW OFFSET SCROLL_DOWN
0010 0318 R DW OFFSET READ_AC_CURRENT
0012 035E R DW OFFSET WRITE_AC_CURRENT
0014 0391 R DW OFFSET WRITE_C_CURRENT
0016 01D9 R DW OFFSET SET_COLOR
0018 046F R DW OFFSET WRITE_DOT
001A 049E R DW OFFSET READ_DOT
001C 075B R DW OFFSET WRITE_TTY
001E 01FF R DW OFFSET VIDEO_STATE
0020 0144 R DW OFFSET VIDEO_RETURN ; Reserved
0022 0144 R DW OFFSET VIDEO_RETURN ; Reserved
0024 0144 R DW OFFSET VIDEO_RETURN ; Reserved
0026 03C3 R DW OFFSET WRITE_STRING ; CASE 19h, Write string
= 0028 EQU 5-M1

0028 VIDEO_IO_1 PROC NEAR ; ENTRY POINT FOR ORG OF065H
0028 FB STI ; INTERRUPTS BACK ON
0029 FC CLD ; SET DIRECTION FORWARD
002A 06 PUSH ES ;
002B 1E PUSH DS ; SAVE SEGMENT REGISTERS
002C 52 PUSH DX
002D 51 PUSH CX
002E 53 PUSH BX
002F 56 PUSH SI
0030 57 PUSH DI
0031 55 PUSH BP
0032 50 PUSH AX ; SAVE AX VALUE
0033 8A C4 MOV AL,AH ; GET INTO LOW BYTE
0035 32 E4 XOR AH,AH ; ZERO TO HIGH BYTE
0037 D1 E0 SAL AX,1 ; *2 FOR TABLE LOOKUP
0039 8B F0 MOV SI,AX ; PUT INTO SI FOR BRANCH
003B 3D 0028 CMP AX,M1L ; TEST FOR WITHIN RANGE
003E 72 04 JB M2 ; BRANCH AROUND BRANCH
0040 58 POP AX ; THROW AWAY THE PARAMETER
0041 E9 0144 R JMP VIDEO_RETURN ; DO NOTHING IF NOT IN RANGE
0044
0044 M2: CALL DDS
0044 E8 0000 E MOV AX,0800H ; SEGMENT FOR COLOR CARD
0047 B8 B800 H MOV D1,EQUIP_FLAG ; GET EQUIPMENT SETTING
004A 8B 3E 0010 R AND D1,30H ; ISOLATE CRT SWITCHES
004E 81 E7 0030 AND D1,30H ; IS SETTING FOR BW CARD?
0052 83 FF 30 CMP D1,30H
0055 75 02 JNE M3
0057 B4 80 MOV AH,080H ; SEGMENT FOR BW CARD
0059 8E C0 MOV ES,AX ; SET UP TO POINT AT VIDEO RAM AREAS
005B 58 POP AX ; RECOVER VALUE

005C 80 FC 13 CMP AH,13H ; TEST FOR WRITE STRING OP
005F 75 07 JNE MM3
0061 55 PUSH BP ; IF IT'S WRITE STRING THEN GET THE
0062 8B EC MOV BP,SP ; STRINGS SEGMENT, SINCE IT GET CLOBBERED
0064 8E 46 10 MOV ES,[BP],ES_POS ;

```

```

0067 5D
0068
0068 8A 26 0049 R
006C 2E: FF AH 0000 R
0071

```

```

MM3: POP BP ;
MOV AH,CRT_MODE ; GET CURRENT MODE INTO AH
JMP WORD PTR CS:[SI+OFFSET M1]
VIDEO_IO_1
ENDP

```

```

; SET_MODE
;-----
; THIS ROUTINE INITIALIZES THE ATTACHMENT TO
; THE SELECTED MODE. THE SCREEN IS BLANKED.
; INPUT
; (AL) = MODE SELECTED (RANGE 0-9)
; OUTPUT
; NONE
;-----

```

```

0071
0071 BA 03D4
0074 03 00
0076 83 FF 30
0079 75 07
007B 80 07
007D BA 03B4
0080 FE C3
0082 8A E0
0084 A2 0049 R
0087 89 16 0063 R
008B 1E
008C 50
008D 52
0092 83 C2 04
0091 8A C3
0093 EE
0094 5A
0095 2B C0
0097 8E D8
0099 C5 1E 0074 R
009D 58
009E B9 0010
00A1 80 FC 02
00A4 72 10
00A6 03 D9
00AB 80 FC 04
00AB 72 09
00AD 03 D9
00AF 80 FC 07
00B2 72 02
00B4 03 D9

```

```

SET_MODE PROC NEAR
MOV DX,03D4H ; ADDRESS OF COLOR CARD
MOV BL,0 ; MODE SET FOR COLOR CARD
CMP D1,30H ; IS BW CARD INSTALLED
JNE M8 ; OK WITH COLOR
MOV AL,7 ; INDICATE BW CARD MODE
MOV DX,03B4H ; ADDRESS OF BW CARD
BL INC ; MODE SET FOR BW CARD
M8: MOV AH,AL ; SAVE MODE IN AH
MOV CRT_MODE,AL ; SAVE IN GLOBAL VARIABLE
MOV ADDR_6845,DX ; SAVE ADDRESS OF BASE
PUSH DS ; SAVE POINTER TO DATA SEGMENT
PUSH AX ; SAVE MODE
PUSH DX ; SAVE OUTPUT PORT VALUE
ADD DX,4 ; POINT TO CONTROL REGISTER
MOV AL,BL ; GET MODE SET FOR CARD
OUT DX,AL ; RESET VIDEO
POP DX ; BACK TO BASE REGISTER
SUB AX,AX ; SET UP FOR ABSO SEGMENT
MOV DS,AX ; ESTABLISH VECTOR TABLE ADDRESSING
ASSUME DS:ABSO
LDS BX,PARAM_PTR ; GET POINTER TO VIDEO PARMS
POP AX ; RECOVER PARMS
ASSUME DS:CODE
MOV CX,M4 ; LENGTH OF EACH ROW OF TABLE
CMP AH,2 ; DETERMINE WHICH ONE TO USE
JC M9 ; MODE IS 0 OR 1
ADD BX,CX ; MOVE TO NEXT ROW OF INIT TABLE
CMP AH,4 ; MODE IS 2 OR 3
ADD BX,CX ; MOVE TO GRAPHICS ROW OF INIT_TABLE
CMP AH,7 ; MODE IS 4,5, OR 6
JC M9 ; MOVE TO BW CARD ROW OF INIT_TABLE
ADD BX,CX

```

;----- BX POINTS TO CORRECT ROW OF INITIALIZATION TABLE

```

00B6 50
00B7 06
00B8 33 C0
00BA 8E C0
00BC 8B 47 0A
00BF 8E E0
00C1 26: A3 0460 R
00C5 07
00C6 32 E4
00C8
00C8 8A C4
00CA EE
00CB 42 0B
00CC FE C4
00CE 8A 07
00D0 EE
00D1 43
00D2 4A
00D3 E2 F3
00D5 58
00D6 1F
00D7 33 FF
00D9 89 3E 004E R
00DD C6 06 0062 R 00
00E2 B9 2000
00E5 80 FC 04
00E8 72 0B
00EA 80 FC 07
00ED 74 04
00EF 33 C0
00F1 EB 05
00F3
00F3 B5 08
00F5 B8 0720
00F8 F3/ AB
00FA A0 0049 R
00FD 32 E4
00FF 8B F0
0101 8B 16 0063 R
0105 83 C2 04
0108 2E: 8A 84 0000 E
010D EE
010E A2 0065 R
0111 2E: 8A 84 0000 E
0116 32 E4
0118 A3 004A R
011B 81 E6 000E

```

```

M9: PUSH AX ; OUT_INIT
; SAVE MODE IN AH
PUSH ES ; SAVE SCREEN BUFFER'S SEGMENT
XOR AX,AX ; ESTABLISH ADDRESSIBILITY TO ABSO
MOV AX,WORD PTR [BX+10] ; GET THE CURSOR MODE FROM THE TABLE
XCHG AH,AL ; PUT CURSOR MODE IN CORRECT POSITION
ASSUME ES:ABSO
MOV ES:WORD PTR DATA_AREA[CURSOR_MODE-DATA],AX
ASSUME ES:VIDEO_RAM
POP ES ; RESTORE THE SCREEN BUFFER'S SEGMENT
XOR AH,AH ; AH WILL SERVE AS REGISTER NUMBER DURING LOOP
;----- LOOP THROUGH TABLE, OUTPUTTING REG ADDRESS, THEN VALUE FROM TABLE
M10: MOV AL,AH ; INIT LOOP
OUT DX,AL ; GET 6845 REGISTER NUMBER
INC DX ; POINT TO DATA PORT
INC AH ; NEXT REGISTER VALUE
MOV AL,[BX] ; GET TABLE VALUE
OUT DX,AL ; OUT TO CHIP
INC BX ; NEXT IN TABLE
DEC DX ; BACK TO POINTER REGISTER
LOOP M10 ; DO THE WHOLE TABLE
POP AX ; GET MODE BACK
POP DS ; RECOVER SEGMENT VALUE
ASSUME DS:DATA

```

;----- FILL REGEN AREA WITH BLANK

```

XOR DI,DI ; SET UP POINTER FOR REGEN
MOV CX,START_DI ; START ADDRESS SAVED IN GLOBAL
MOV ACTIVE_PAGE,0 ; SET PAGE VALUE
MOV CX,8192 ; NUMBER OF WORDS IN COLOR CARD
CMP AH,4 ; TEST FOR GRAPHICS
JNC M12 ; NO GRAPHICS_INIT
JMP AH,7 ; TEST FOR BW CARD
M11: MOV BH,CARD_INIT ; BW CARD INIT
XOR AX,AX ; FILL FOR GRAPHICS MODE
JMP SHORT M13 ; CLEAR BUFFER
M12: MOV CH,08H ; BUFFER SIZE ON BW CARD (2048)
MOV AX,'!+7*256 ; NO GRAPHICS_INIT
M13: REP STOSW ; FILL CHAR FOR ALPHA
; CLEAR BUFFER
; FILL THE REGEN BUFFER WITH BLANKS

```

;----- ENABLE VIDEO AND CORRECT PORT SETTING

```

MOV AL,CRT_MODE ; GET THE MODE
XOR AH,AH ; INTO AX REGISTER
MOV SI,AX ; TABLE POINTER, INDEXED BY MODE
MOV DX,ADDR_6845 ; PREPARE TO OUTPUT TO VIDEO ENABLE PORT
ADD DX,4
MOV AL,CS:[SI + OFFSET BYTE PTR M7]
OUT DX,AL ; SET VIDEO ENABLE PORT
MOV CRT_MODE_SET,AL ; SAVE THAT VALUE

```

;----- DETERMINE NUMBER OF COLUMNS, BOTH FOR ENTIRE DISPLAY
;----- AND THE NUMBER TO BE USED FOR TTY INTERFACE

```

MOV AL,CS:[SI + OFFSET BYTE PTR M6]
XOR AH,AH
MOV CRT_COLS,AX ; NUMBER OF COLUMNS IN THIS SCREEN

```

;----- SET CURSOR POSITIONS

```

AND SI,0EH ; WORD OFFSET INTO CLEAR LENGTH TABLE

```

SECTION 5

```

011F 2E: 8B 8C 0000 E          MOV     CX,CS:[SI + OFFSET M5] ; LENGTH TO CLEAR
0124 89 0E 004C R          MOV     CRT_LEN,CX             ; SAVE LENGTH OF CRT -- NOT USED FOR BW
0128 B9 0008 R          MOV     CX,8                   ; CLEAR ALL CURSOR POSITIONS
012B BF 0050 R          MOV     DI,OFFSET CURSOR_POSN ; ESTABLISH SEGMENT
012E 1E                   PUSH    DS                     ;
012F 07                   POP     ES                     ; ESTABLISH SEGMENT
0130 33 C0                XOR     AX,AX                  ; ADDRESSING
0132 F3/ AB              REP     STOSW                  ; FILL WITH ZEROES

;----- SET UP OVERSCAN REGISTER

0134 42                   INC     DX                     ; SET OVERSCAN PORT TO A DEFAULT
0135 80 30                MOV     AL,30H                ; VALUE OF 30H FOR ALL MODES EXCEPT 640X200
0137 80 3E 0049 R 06     CMP     CRT_MODE,6           ; SEE IF THE MODE IS 640X200 BW
013C 75 02                JNZ    M14                    ; IF IT ISNT 640X200, THEN GOTO REGULAR
013E B0 3F                MOV     AL,3FH                ; IF IT IS 640X200, THEN PUT 1 IN 3FH
0140 EE                   OUT     DX,AL                 ; OUTPUT THE CORRECT VALUE TO 3D9 PORT
0141 A2 0066 R          MOV     CRT_PALLETTE,AL      ; SAVE THE VALUE FOR FUTURE USE

;----- NORMAL RETURN FROM ALL VIDEO RETURNS

0144                   VIDEO_RETURN:
0144 5D                   POP     BP
0145 5F                   POP     DI
0146 5E                   POP     SI
0147 5B                   POP     BX
0148                   M15:
0148 59                   POP     CX                     ; VIDEO_RETURN_C
0149 5A                   POP     DX
014A 1F                   POP     DS
014B 07                   POP     ES                     ; RECOVER SEGMENTS
014C CF                   IRET                            ; ALL DONE
014D

SET_MODE                ENDP
;-----
; SET_CTYPE
; THIS ROUTINE SETS THE CURSOR VALUE
; INPUT (CX) HAS CURSOR VALUE CH-START LINE, CL-STOP LINE
; OUTPUT
; NONE
;-----
014D                   SET_CTYPE PROC NEAR
014D B4 0A                MOV     AH,10                 ; 6845 REGISTER FOR CURSOR SET
014F 89 0E 0060 R        MOV     CURSOR_MODE,CX       ; SAVE IN DATA AREA
0153 EB 0158 R          JMP     VIDEO_RETURN         ; OUTPUT CX REG
0156 EB EC

;----- THIS ROUTINE OUTPUTS THE CX REGISTER TO THE 6845 REGS NAMED IN AH

0158                   M16:
0158 8B 16 0063 R        MOV     DX,ADDR_6845         ; ADDRESS REGISTER
015C 8A C4                MOV     AL,AH                 ; GET VALUE
015E EE                   OUT     DX,AL                 ; REGISTER SET
015F 42                   INC     DX                     ; DATA REGISTER
0160 EB 00                JMP     SHORT $+2             ; IO DELAY
0162 8A C5                MOV     AL,CH                 ; DATA
0164 EE                   OUT     DX,AL                 ;
0165 4A                   DEC     DX                     ;
0166 EB 00                JMP     SHORT $+2             ; IO DELAY
0168 8A C4                MOV     AL,AH                 ;
016A FE C0                INC     AL                     ; POINT TO OTHER DATA REGISTER
016C EE                   OUT     DX,AL                 ; SET FOR SECOND REGISTER
016D 42                   INC     DX                     ;
016E EB 00                JMP     SHORT $+2             ; IO DELAY
0170 8A C1                MOV     AL,CL                 ; SECOND DATA VALUE
0172 EE                   OUT     DX,AL                 ;
0173 C3                   RET                            ; ALL DONE
0174                   SET_CTYPE ENDP
;-----
; SET_CPOS
; THIS ROUTINE SETS THE CURRENT CURSOR POSITION TO THE
; NEW X-Y VALUES PASSED
; INPUT
; DX - ROW,COLUMN OF NEW CURSOR
; BH - DISPLAY PAGE OF CURSOR
; OUTPUT
; CURSOR IS SET AT 6845 IF DISPLAY PAGE IS CURRENT DISPLAY
;-----
0174                   SET_CPOS PROC NEAR
0174 8A CF                MOV     CL,BH                 ;
0176 32 ED                XOR     CH,CH                 ; ESTABLISH LOOP COUNT
0178 D1 E1                SAL     CX,1                  ; WORD OFFSET
017A 8B F1                MOV     SI,CX                 ; USE INDEX REGISTER
017C 89 94 0050 R        MOV     MOV [SI+OFFSET CURSOR_POSN],DX ; SAVE THE POINTER
0180 3B 3E 0062 R        CMP     ACTIVE_PAGE,BH       ;
0184 75 05                JNZ    M17                    ; SET_CPOS_RETURN
0186 8B C2                MOV     AX,DX                 ; GET ROW/COLUMN TO AX
0188 EB 018D R          CALL    M18                   ; CURSOR SET
018B                   SET_CPOS_RETURN
018B EB B7                JMP     VIDEO_RETURN         ;
018D                   SET_CPOS ENDP
;-----
; SET CURSOR POSITION, AX HAS ROW/COLUMN FOR CURSOR

018D                   M18 PROC NEAR
018D E8 0211 R          CALL    POSITION              ; DETERMINE LOCATION IN REGEN BUFFER
0190 8B C8                MOV     CX,AX                 ;
0192 03 0E 004E R        ADD     CX,CRT_START         ; ADD IN THE START ADDRESS FOR THIS PAGE
0196 D1 F9                SAR     CX,1                  ; DIVIDE BY 2 FOR CHAR ONLY COUNT
0198 B4 0E                MOV     AH,14                 ; REGISTER NUMBER FOR CURSOR
019A EB 0158 R          CALL    M16                   ; OUTPUT THE VALUE TO THE 6845
019D C3                   RET
019E                   M18 ENDP
;-----
; READ_CURSOR
; THIS ROUTINE READS THE CURRENT CURSOR VALUE FROM THE
; 6845, FORMATS IT, AND SENDS IT BACK TO THE CALLER
; INPUT
; BH - PAGE OF CURSOR
; OUTPUT
; DX - ROW, COLUMN OF THE CURRENT CURSOR POSITION
; CX - CURRENT CURSOR MODE
;-----
019E                   READ_CURSOR PROC NEAR
019E 8A DF                MOV     BL,BH                 ;
01A0 32 FF                XOR     BH,BH                 ; WORD OFFSET
01A2 D1 E3                SAL     BX,1                  ;
01A4 8B 97 0050 R        MOV     DX,[BX+OFFSET CURSOR_POSN]
01A8 8B 0E 0060 R        MOV     CX,CURSOR_MODE
01AC 5D                   POP     BP
01AD 5F                   POP     DI
01AE 5E                   POP     SI
01AF 5B                   POP     BX
01B0 58                   POP     AX                     ; DISCARD SAVED CX AND DX

```

01B1 58
 01B2 1F
 01B3 07
 01B4 CF
 01B5

```

POP AX
POP DS
POP ES
IRET
READ_CURSOR ENDP

```

```

-----
ACT_DISP_PAGE
THIS ROUTINE SETS THE ACTIVE DISPLAY PAGE, ALLOWING
THE FULL USE OF THE RAM SET ASIDE FOR THE VIDEO ATTACHMENT
INPUT
AL HAS THE NEW ACTIVE DISPLAY PAGE
OUTPUT
THE 6845 IS RESET TO DISPLAY THAT PAGE
-----

```

01B5
 01B5 A2 0062 R
 01B8 8B 0E 004C R
 01BC 98
 01BD 50
 01BE F7 E1
 01C0 A3 004E R
 01C3 8B C8
 01C5 D1 F9
 01C7 B4 0C
 01C9 E8 0158 R
 01CC 58
 01CD 01 E3
 01CF 8B 87 0050 R
 01D3 E8 018D R
 01D6 E9 0144 R
 01D9

```

ACT_DISP_PAGE PROC NEAR
MOV ACTIVE_PAGE,AL ; SAVE ACTIVE PAGE VALUE
MOV CX,CRT_LEN ; GET SAVED LENGTH OF REGEN BUFFER
CBW ; CONVERT AL TO WORD
PUSH AX ; SAVE PAGE VALUE
MUL CX ; DISPLAY PAGE TIMES REGEN LENGTH
MOV CRT_START,AX ; SAVE START ADDRESS FOR LATER REQUIREMENTS
MOV CX,AX ; START ADDRESS TO CX
SAR CX,1 ; DIVIDE BY 2 FOR 6845 HANDLING
MOV AH,12 ; 6845 REGISTER FOR START ADDRESS
CALL M16
POP BX ; RECOVER PAGE VALUE
SAL BX,1 ; *2 FOR WORD OFFSET
MOV AX,[BX + OFFSET CURSOR_POSN] ; GET CURSOR FOR THIS PAGE
CALL M18 ; SET THE CURSOR POSITION
JMP VIDEO_RETURN
ACT_DISP_PAGE ENDP

```

```

-----
SET_COLOR
THIS ROUTINE WILL ESTABLISH THE BACKGROUND COLOR, THE OVERSCAN COLOR,
AND THE FOREGROUND COLOR SET FOR MEDIUM RESOLUTION GRAPHICS
INPUT
(BH) HAS COLOR ID
IF BH=0, THE BACKGROUND COLOR VALUE IS SET
FROM THE LOW BITS OF BL (0-31)
IF BH=1, THE PALLETTE SELECTION IS MADE
BASED ON THE LOW BIT OF BL:
0 = GREEN, RED, YELLOW FOR COLORS 1,2,3
1 = BLUE, CYAN, MAGENTA FOR COLORS 1,2,3
OUTPUT
THE COLOR SELECTION IS UPDATED
-----

```

01D9
 01D9 8B 16 0063 R
 01DD 83 C2 05
 01E0 A0 0066 R
 01E3 0A FF
 01E5 75 0E

```

SET_COLOR PROC NEAR
MOV DX,ADDR_6845 ; I/O PORT FOR PALLETTE
ADD DX,5 ; OVERSCAN PORT
MOV AL,CRT_PALLETTE ; GET THE CURRENT PALLETTE VALUE
OR BH,BH ; IS THIS COLOR 0?
JNZ M20 ; OUTPUT COLOR 1

```

```

;----- HANDLE COLOR 0 BY SETTING THE BACKGROUND COLOR
AND AL,DE0H ; TURN OFF LOW 5 BITS OF CURRENT
AND BL,01FH ; TURN OFF HIGH 3 BITS OF INPUT VALUE
OR AL,BL ; PUT VALUE INTO REGISTER
M19: ; OUTPUT THE PALLETTE
OUT DX,AL ; OUTPUT COLOR SELECTION TO 309 PORT
MOV CRT_PALLETTE,AL ; SAVE THE COLOR VALUE
JMP VIDEO_RETURN

```

01E7 24 E0
 01E9 80 E3 1F
 01EC 0A C3
 01EE
 01EE EE
 01EF A2 0066 R
 01F2 E9 0144 R

```

;----- HANDLE COLOR 1 BY SELECTING THE PALLETTE TO BE USED
M20:
AND AL,0DFH ; TURN OFF PALLETTE SELECT BIT
SHR BL,1 ; TEST THE LOW ORDER BIT OF BL
JNC M19 ; ALREADY DONE
OR AL,20H ; TURN ON PALLETTE SELECT BIT
JMP M19 ; GO DO IT

```

01F5
 01F5 24 0F
 01F7 D0 EB
 01F9 73 F3
 01FB 0C 20
 01FD EB EF
 01FF

```

SET_COLOR ENDP
-----
VIDEO_STATE
RETURNS THE CURRENT VIDEO STATE IN AX
AH = NUMBER OF COLUMNS ON THE SCREEN
AL = CURRENT VIDEO MODE
BH = CURRENT ACTIVE PAGE
-----

```

01FF
 01FF 8A 26 004A R
 0203 A0 0049 R
 0206 8A 3E 0062 R
 020A 5D
 020B 5F
 020C 5E
 020D 59
 020E E9 0148 R
 0211

```

VIDEO_STATE PROC NEAR
MOV AH,BYTE PTR CRT_COLS ; GET NUMBER OF COLUMNS
MOV AL,CRT_MODE ; CURRENT MODE
MOV BH,ACTIVE_PAGE ; GET CURRENT ACTIVE PAGE
POP BP ; RECOVER REGISTERS
POP DI
POP SI
POP CX ; DISCARD SAVED BX
JMP M15 ; RETURN TO CALLER
VIDEO_STATE ENDP

```

```

-----
POSITION
THIS SERVICE ROUTINE CALCULATES THE REGEN BUFFER ADDRESS
OF A CHARACTER IN THE ALPHA MODE
INPUT
AX = ROW, COLUMN POSITION
OUTPUT
AX = OFFSET OF CHAR POSITION IN REGEN BUFFER
-----

```

0211
 0211 53
 0212 8B D8
 0214 8A C4
 0216 F6 26 004A R
 021A 32 FF
 021C 03 C3
 021E D1 E0
 0220 5B
 0221 C3
 0222

```

POSITION PROC NEAR
PUSH BX ; SAVE REGISTER
MOV BX,AX
MOV AL,AH ; ROWS TO AL
MUL BYTE PTR CRT_COLS ; DETERMINE BYTES TO ROW
XOR BH,BH
ADD AX,BX ; ADD IN COLUMN VALUE
SAL AX,1 ; *2 FOR ATTRIBUTE BYTES
POP BX
RET
POSITION ENDP

```

```

-----
SCROLL_UP
THIS ROUTINE MOVES A BLOCK OF CHARACTERS UP
ON THE SCREEN
INPUT
(AH) = CURRENT CRT MODE
(AL) = NUMBER OF ROWS TO SCROLL
(CX) = ROW/COLUMN OF UPPER LEFT CORNER
(DX) = ROW/COLUMN OF LOWER RIGHT CORNER
(BH) = ATTRIBUTE TO BE USED ON BLANKED LINE
(DS) = DATA SEGMENT
(ES) = REGEN BUFFER SEGMENT
OUTPUT
NONE -- THE REGEN BUFFER IS MODIFIED
ASSUME CS:CODE,DS:DATA,ES:DATA

```

```

0222                SCROLL_UP      PROC   NEAR
0222  E8 0303 R      CALL    TEST_LINE_COUNT ;
0225  80 FC 04      CMP     AH,4          ; TEST FOR GRAPHICS MODE
0226  72 08          JC      N1            ; HANDLE SEPARATELY
022A  80 FC 07      CMP     AH,7          ; TEST FOR BW CARD
022D  74 03          JE      N1            ;
022F  E9 0405 R     JMP     GRAPHICS_UP  ;
0232                N1:            ; UP_CONTINUE
0232  53            PUSH    BX          ; SAVE FILL ATTRIBUTE IN BH
0233  8B C1          MOV     AX,CX        ; UPPER LEFT POSITION
0235  EB 026F R     CALL    SCROLL_POSITION ; DO SETUP FOR SCROLL
0238  74 31          JZ     N7            ; BLANK FIELD
023A  03 F0          ADD    SI,AX         ; FROM ADDRESS
023C  8A E6          MOV    AH,DH        ; # ROWS IN BLOCK
023E  2A E3          SUB    AH,BL        ; # ROWS TO BE MOVED
0240                N2:            ; ROW_LOOP
0240  E8 02B6 R     CALL    N10         ; MOVE ONE ROW
0243  03 F5          ADD    SI,BP        ; POINT TO NEXT LINE IN BLOCK
0245  03 FD          ADD    DI,BP        ; COUNT OF LINES TO MOVE
0247  FE CC          DEC    AH           ; ROW_LOOP
0249  75 F5          JNZ   N2            ;
024B                N3:            ; CLEAR ENTRY
024B  58            POP     AX           ; RECOVER ATTRIBUTE IN AH
024C  80 20          MOV    AL,' '       ; FILL WITH BLANKS
024E                N4:            ; CLEAR_LOOP
024E  E8 02BF R     CALL    N11         ; CLEAR THE ROW
0251  03 FD          ADD    DI,BP        ; POINT TO NEXT LINE
0253  FE C8          DEC    BL           ; COUNTER OF LINES TO SCROLL
0255  75 F7          JNZ   N4            ; CLEAR_LOOP
0257                N5:            ; SCROLL_END
0257  E8 0000 E     CALL    DDS         ;
0259  80 3E 0049 R 07 CMP    CRT_MODE,7   ; IS THIS THE BLACK AND WHITE CARD
025F  74 07          JB     N6            ; IF SO, SKIP THE MODE RESET
0261  A0 0065 R     MOV    AL,CRT_MODE_SET ; GET THE VALUE OF THE MODE SET
0264  BA 03DBH      MOV    DX,03DBH    ; ALWAYS SET COLOR CARD PORT
0267  EE            OUT    DX,AL        ;
0268                N6:            ; VIDEO_RET_HERE
0268  E9 0144 R     JMP     VIDEO_RETURN ;
026B                N7:            ; BLANK FIELD
026B  8A DE          MOV    BL,DH        ; GET ROW COUNT
026D  EB DC          JMP     N3           ; GO CLEAR THAT AREA
026F                SCROLL_UP      ENDP

;----- HANDLE COMMON SCROLL SET UP HERE

026F                SCROLL_POSITION PROC   NEAR
026F  80 3E 0049 R 02 CMP    CRT_MODE,2   ; TEST FOR SPECIAL CASE HERE
0274  72 19          JB     N9            ; HAVE TO HANDLE 80X25 SEPARATELY
0276  80 3E 0049 R 03 CMP    CRT_MODE,3   ;
027B  77 12          JA     N9            ;
027D                ;----- 80X25 COLOR CARD SCROLL
027D  52            PUSH    DX           ;
027E  BA 03DA      MOV    DX,3DAH     ; GUARANTEED TO BE COLOR CARD HERE
0281  50            PUSH    AX           ;
0282                N8:            ; WAIT_DISP_ENABLE
0282  EC            IN     AL,DX        ; GET PORT
0283  A8 08          TEST   AL,8        ; WAIT FOR VERTICAL RETRACE
0285  74 FB          JZ     N8            ; WAIT_DISP_ENABLE
0287  80 25          MOV    AL,25H     ;
0289  BA 03DBH      MOV    DX,03DBH   ;
028C  EE            OUT    DX,AL        ; TURN OFF VIDEO
028D  58            POP     AX           ; DURING VERTICAL RETRACE
028E  5A            POP     DX           ;
028F                N9:            ; CONVERT TO REGEN POINTER
028F  E8 0211 R     CALL    POSITION     ;
0292  03 06 004E R 01 ADD    AX,CRT_START ; OFFSET OF ACTIVE PAGE
0296  8B F8          MOV    DI,AX       ; TO ADDRESS FOR SCROLL
0298  8B F0          MOV    SI,AX       ; FROM ADDRESS FOR SCROLL
029A  2B D1          SUB    DX,CX       ; DX = #ROWS, #COLS IN BLOCK
029C  FE C6          DEC    DI           ;
029E  FE C2          DEC    DI           ; INCREMENT FOR 0 ORIGIN
02A0  32 ED          XOR    CH,CH       ; SET HIGH BYTE OF COUNT TO ZERO
02A2  8B 2E 004A R 01 MOV    BP,CRT_COLS ; GET NUMBER OF COLUMNS IN DISPLAY
02A6  03 ED          ADD    BP,DI        ; TIMES 2 FOR ATTRIBUTE BYTE
02A8  8A C3          MOV    AL,BL       ; GET LINE COUNT
02AA  F6 26 004A R 01 MUL   BYTE PTR CRT_COLS ; #2 FOR ATTRIBUTE BYTE
02AE  03 C0          ADD    AX,AX       ; *2 DETERMINE OFFSET TO FROM ADDRESS
02B0  06            PUSH    ES          ;
02B1  1F            POP     DS          ; ESTABLISH ADDRESSING TO REGEN BUFFER
02B2  80 FB 00      CMP    BL,0        ; FOR BOTH POINTERS
02B5  C3            RET                ; 0 SCROLL MEANS BLANK FIELD
02B6                ; RETURN WITH FLAGS SET
02B6                SCROLL_POSITION ENDP

;----- MOVE_ROW
02B6                N10:           ;
02B6  8A CA          MOV    CL,DL        ; GET # OF COLS TO MOVE
02B8  56            PUSH    SI          ;
02B9  57            PUSH    DI          ; SAVE START ADDRESS
02BA  F3/ A5        REP    MOVSW        ; MOVE THAT LINE ON SCREEN
02BC  5F            POP     DI          ;
02BD  5E            POP     SI          ; RECOVER ADDRESSES
02BE  C3            RET                ;
02BF                N10:           ;
02BF                ;----- CLEAR_ROW
02BF                N11:           ;
02BF  8A CA          MOV    CL,DL        ; GET # COLUMNS TO CLEAR
02C1  57            PUSH    DI          ;
02C2  F3/ AB        REP    STOSW        ; STORE THE FILL CHARACTER
02C4  5F            POP     DI          ;
02C5  C3            RET                ;
02C6                N11:           ;
02C6                ;-----
02C6                ; SCROLL_DOWN
02C6                ; THIS ROUTINE MOVES THE CHARACTERS WITHIN A DEFINED
02C6                ; BLOCK DOWN ON THE SCREEN, FILLING THE TOP LINES
02C6                ; WITH A DEFINED CHARACTER
02C6                ; INPUT
02C6                ; (AH) = CURRENT CRT MODE
02C6                ; (AL) = NUMBER OF LINES TO SCROLL
02C6                ; (CX) = UPPER LEFT CORNER OF REGION
02C6                ; (DX) = LOWER RIGHT CORNER OF REGION
02C6                ; (BH) = FILL CHARACTER
02C6                ; (DS) = DATA SEGMENT
02C6                ; (ES) = REGEN SEGMENT
02C6                ; OUPUT
02C6                ; NONE -- SCREEN IS SCROLLED
02C6                ;-----
02C6                SCROLL_DOWN   PROC   NEAR
02C6  FD            STD     ; DIRECTION FOR SCROLL DOWN
02C7  E8 0303 R     CALL    TEST_LINE_COUNT ;
02CA  80 FC 04      CMP     AH,4          ; TEST FOR GRAPHICS
02CD  72 08          JC      N12         ;

```

```

02CF 80 FC 07          CMP    AH,7          ; TEST FOR BW CARD
02D2 74 03            JE     N12           ;
02D4 E9 052E R       JMP    GRAPHICS_DOWN ;
02D7                ; CONTINUE_DOWN
02D7 53                PUSH   BX            ; SAVE ATTRIBUTE IN BH
02D8 BB C2            MOV    AX,DX         ; LOWER RIGHT CORNER
02DA EB 026F R       CALL   SCROLL_POSITION ; GET REGEN LOCATION
02DD 74 20            JZ     N16           ;
02DF 2B F0            SUB    SI,AX         ; SI IS FROM ADDRESS
02E1 BA E6            MOV    AH,DX         ; GET TOTAL # ROWS
02E3 2A E3            SUB    COUNT,AX      ; COUNT TO MOVE IN SCROLL
02E5                ;
02E5 EB 02B6 R       CALL   N10           ; MOVE ONE ROW
02E8 2B F5            SUB    SI,BP         ;
02EA 2B F0            SUB    DI,BP         ;
02EC FE CC            DEC    AH            ;
02EF 75 F5            JNZ   N13           ;
02FO 58                POP    AX            ; RECOVER ATTRIBUTE IN AH
02F1 80 20            MOV    AL,' '       ;
02F3                ;
02F3 EB 02BF R       CALL   N11           ; CLEAR ONE ROW
02F6 2B F0            SUB    DI,BP         ; GO TO NEXT ROW
02F8 FE CB            DEC    BL            ;
02FA 75 F7            JNZ   N15           ;
02FC E9 0257 R       JMP    N15           ; SCROLL_END
02FF                ;
02FF BA DE            MOV    BL,DH         ;
0301 EB ED            JMP    N14           ;
0303                SCROLL_DOWN        ENDP
;
;----- TEST IF AMOUNT OF LINES TO BE SCROLLED = AMOUNT OF LINES IN WINDOW
;----- IF TRUE THEN WE ADJUST AL, IF FALSE WE RETURN...
0303                TEST_LINE_COUNT PROC NEAR
;
;-----
0303 8A D8            MOV    BL,AL         ; SAVE LINE COUNT IN BL
0305 0A C0            OR     AL,AL         ; TEST IF AL IS ALREADY ZERO
0307 74 0E            JZ     BL_SET        ; IF IT IS THEN RETURN...
0309 50                PUSH   AX            ; SAVE AX
030A BA C6            MOV    AL,DH         ; SUBTRACT LOWER ROW FROM UPPER ROW
030C 2A C5            SUB    AL,CH         ;
030E FE C0            DEC    AL            ; ADJUST DIFFERENCE BY 1
0310 3A C3            CMP    AL,BL         ; TEST IF LINE COUNT = AMOUNT OF ROWS IN WINDOW
0312 58                POP    AX            ; RESTORE AX
0313 75 02            JNE   BL_SET        ; IF NOT THEN WE'RE ALL SET
0315 2A D8            SUB    BL,BL         ; OTHERWISE SET BL TO ZERO
0317                BL_SET:            RET
0318                ; RETURN
;-----
0318                TEST_LINE_COUNT ENDP
;-----
; READ_AC_CURRENT
; THIS ROUTINE READS THE ATTRIBUTE AND CHARACTER AT THE CURRENT
; CURSOR POSITION AND RETURNS THEM TO THE CALLER
; INPUT
; (AH) = CURRENT CRT MODE
; (BH) = DISPLAY PAGE ( ALPHA MODES ONLY )
; (DS) = DATA SEGMENT
; (ES) = REGEN SEGMENT
; OUTPUT
; (AL) = CHAR READ
; (AH) = ATTRIBUTE READ
;-----
0318                ASSUME CS:CODE,DS:DATA,ES:DATA
0318                READ_AC_CURRENT PROC NEAR
; IS THIS GRAPHICS
0318 80 FC 04          CMP    AH,4
031B 72 08            JC     P1
; IS THIS BW CARD
031D 80 FC 07          CMP    AH,7
0320 74 03            JE     P1
0322 E9 0669 R       JMP    GRAPHICS_READ
P1:                ; READ_AC_CONTINUE
0325 EB 0342 R       CALL   FIND_POSITION
0328 8B F3            MOV    SI,BX
;----- WAIT FOR HORIZONTAL RETRACE
032A 8B 16 0063 R    MOV    DX,ADDR_6845 ; GET BASE ADDRESS
032E 83 C2 06        ADD    DX,6          ; POINT AT STATUS PORT
0331 06                PUSH   ES            ;
0332 1F                POP    DS            ; GET SEGMENT FOR QUICK ACCESS
0333                ; WAIT FOR RETRACE LOW
0333 EC                IN     AL,DX         ; GET STATUS
0334 A8 01            TEST  AL,1           ; IS HORIZ RETRACE LOW
0336 75 FB            JNZ   P2             ; WAIT UNTIL IT IS
0338 FA                CLI     P2           ; NO MORE INTERRUPTS
0339                ; WAIT FOR RETRACE HIGH
0339 EC                IN     AL,DX         ; GET STATUS
033A A8 01            TEST  AL,1           ; IS IT HIGH
033C 74 FB            JZ     P3            ; WAIT UNTIL IT IS
033E AD                LODSW  JMP           ; GET THE CHAR/ATTR
033F E9 0144 R       JMP    VIDEO_RETURN
0342                READ_AC_CURRENT ENDP
;-----
0342                FIND_POSITION PROC NEAR
0342 8A CF            MOV    CL,BH         ; DISPLAY PAGE TO CX
0344 32 ED            XOR    CH,CH         ;
0346 8B F1            MOV    SI,CX         ; MOVE TO SI FOR INDEX
0348 D1 E6            SAL    SI,1          ; * 2 FOR WORD OFFSET
034A 8B 84 0050 R    MOV    AX,[SI+OFFSET_CURSOR_POSN] ; GET ROW/COLUMN OF THAT PAGE
034E 33 D6            XOR    BX,BX         ; SET START ADDRESS TO ZERO
0350 E3 06            XOR    P5            ; NO PAGE
0352                ; PAGE LOOP
0352 03 1E 004C R    ADD    BX,CRT_LEN   ; LENGTH OF BUFFER
0356 E2 FA            LOOP  P4             ;
P4:                ; NO PAGE
0358                ; LENGTH OF BUFFER
0358 EB 0211 R       CALL   POSITION       ; DETERMINE LOCATION IN REGEN
035B 03 D8            ADD    BX,AX         ; ADD TO START OF REGEN
035D C3                RET
035E                FIND_POSITION ENDP
;-----
; WRITE_AC_CURRENT
; THIS ROUTINE WRITES THE ATTRIBUTE AND CHARACTER AT
; THE CURRENT CURSOR POSITION
; INPUT
; (AH) = CURRENT CRT MODE
; (BH) = DISPLAY PAGE
; (CX) = COUNT OF CHARACTERS TO WRITE
; (AL) = CHAR TO WRITE
; (BL) = ATTRIBUTE OF CHAR TO WRITE
; (DS) = DATA SEGMENT
; (ES) = REGEN SEGMENT
; OUTPUT
; NONE
;-----

```

```

035E
035E 80 FC 04
0361 72 08
0363 80 FC 07
0366 74 03
0368 E9 0588 R
0368
0368 8A E3
036D 50
036E 51
036F E8 0342 R
0372 8B FB
0374 59
0375 5B
0376

WRITE_AC_CURRENT PROC NEAR
    CMP AH,4 ; IS THIS GRAPHICS
    JC P6 ;
    CMP AH,7 ; IS THIS BW CARD
    JE P6
    JMP GRAPHICS_WRITE
P6:
    MOV AH,BL ; WRITE_AC_CONTINUE
    PUSH AX ; GET ATTRIBUTE TO AH
    PUSH CX ; SAVE ON STACK
    CALL FIND_POSITION ; SAVE WRITE COUNT
    MOV DI,BX ; ADDRESS TO DI REGISTER
    POP CX ; WRITE COUNT
    POP BX ; CHARACTER IN BX REG
    WRITE_LOOP
P7:
;----- WAIT FOR HORIZONTAL RETRACE
    MOV DX,ADDR_6845 ; GET BASE ADDRESS
    ADD DX,6 ; POINT AT STATUS PORT
P8:
    IN AL,DX ; GET STATUS
    TEST AL,1 ; IS IT LOW
    JNZ P8 ; WAIT UNTIL IT IS
    CLI ; NO MORE INTERRUPTS
P9:
    IN AL,DX ; GET STATUS
    TEST AL,1 ; IS IT HIGH
    JZ P9 ; WAIT UNTIL IT IS
    MOV AX,BX ; RECOVER THE CHAR/ATTR
    STOSW ; PUT THE CHAR/ATTR
    STI ; INTERRUPTS BACK ON
    LOOP P7 ; AS MANY TIMES AS REQUESTED
    JMP VIDEO_RETURN
WRITE_AC_CURRENT ENDP
;-----
; WRITE_C_CURRENT
; THIS ROUTINE WRITES THE CHARACTER AT
; THE CURRENT CURSOR POSITION, ATTRIBUTE UNCHANGED
; INPUT
; (AH) = CURRENT CRT MODE
; (BH) = DISPLAY PAGE
; (CX) = COUNT OF CHARACTERS TO WRITE
; (AL) = CHAR TO WRITE
; (DS) = DATA SEGMENT
; (ES) = REGEN SEGMENT
; OUTPUT
; NONE
;-----
0391
0391 80 FC 04
0394 72 08
0396 80 FC 07
0399 74 03
039B E9 0588 R
039E
039E 50
039F 51
03A0 E8 0342 R
03A3 8B FB
03A5 59
03A6 5B
03A7

WRITE_C_CURRENT PROC NEAR
    CMP AH,4 ; IS THIS GRAPHICS
    JC P10 ;
    CMP AH,7 ; IS THIS BW CARD
    JE P10
    JMP GRAPHICS_WRITE
P10:
    PUSH AX ; SAVE ON STACK
    PUSH CX ; SAVE WRITE COUNT
    CALL FIND_POSITION ; ADDRESS TO DI
    MOV DI,BX ; WRITE COUNT
    POP CX ; BL HAS CHAR TO WRITE
    POP BX ; WRITE_LOOP
P11:
;----- WAIT FOR HORIZONTAL RETRACE
    MOV DX,ADDR_6845 ; GET BASE ADDRESS
    ADD DX,6 ; POINT AT STATUS PORT
P12:
    IN AL,DX ; GET STATUS
    TEST AL,1 ; IS IT LOW
    JNZ P12 ; WAIT UNTIL IT IS
    CLI ; NO MORE INTERRUPTS
P13:
    IN AL,DX ; GET STATUS
    TEST AL,1 ; IS IT HIGH
    JZ P13 ; WAIT UNTIL IT IS
    MOV AL,BL ; RECOVER CHAR
    STI ; ENABLE INTS.
    STOSB ; PUT THE CHAR/ATTR
    INC DI ; BUMP POINTER PAST ATTRIBUTE
    LOOP P11 ; AS MANY TIMES AS REQUESTED
    JMP VIDEO_RETURN
WRITE_C_CURRENT ENDP
page
;-----
; WRITE_STRING
; This routine writes a string of characters to the crt.
; INPUT
; (AL) = WRITE STRING COMMAND 0 - 3
; (BH) = DISPLAY PAGE
; (CX) = COUNT OF CHARACTERS TO WRITE, IF CX == 0 THEN RETURN
; (BL) = ATTRIBUTE OF CHAR TO WRITE IF AL == 0 || AL == 1
; (ES) = STRING SEGMENT
; (BP) = STRING OFFSET
; OUTPUT
; N/A
;-----
03C3
WRITE_STRING PROC NEAR
    CMP AL,04 ; TEST FOR INVALID WRITE STRING OPTION
    JB W0 ; IF OPTION INVALID THEN RETURN
    JMP DONE
W0:
    OR CX,CX ; TEST FOR ZERO LENGTH STRING
    JNZ W1
    JMP DONE ; IF ZERO LENGTH STRING THEN RETURN
    PUSH BX ; SAVE PAGE AND POSSIBLE ATTRIBUTE
    MOV BL,BH ; GET CURRENT CURSOR POSITION
    XOR BH,BH
    SAL BX,1
    MOV SI,[BX+OFFSET_CURSOR_POSN] ; RESTORE BX
    POP BX ; SAVE CURRENT CURSOR POSITION
    PUSH SI
    PUSH AX ; SAVE WRITE STRING OPTION
    MOV AX,0200H ; SET NEW CURSOR POSITION
    INT 10H
    POP AX ; RESTORE WRITE STRING OPTION
WRITE_CHAR:
    CX
    PUSH
    BX

```

```

03E7 50          PUSH  AX
03E8 06          PUSH  ES
03E9 86 E0       XCHG  AH,AL
03EB 26: 8A 46 00 MOV  AL,ES:[BP]
03EF 45          INC   BP
;----- TEST FOR SPECIAL CHARACTER'S
03F0 3C 08       CMP   AL,8
03F2 74 0C       JE    DO_TTY
03F4 3C 0D       CMP   AL,0DH
03F6 74 08       JE    DO_TTY
03F8 3C 0A       CMP   AL,0AH
03FA 74 04       JE    DO_TTY
03FC 3C 07       CMP   AL,07H
03FE 75 13       JNE   GET_ATTRIBUTE
0400          DO_TTY:
0400 B4 0E       MOV   AH,14
0402 CD 10       INT  10H
0404 8A DF       MOV   BL,BH
0406 D0 E7       SAL  BH,1
0408 8B 97 0050 R MOV  EB,[BX+OFFSET CURSOR_POSN]
040C 07          POP   ES
040D 58          POP   AX
040E 5B          POP   BX
040F 59          POP   CX
0410 EB 32 90     JMP   ROWS_SET

0413          GET_ATTRIBUTE:
0413 B9 0001      MOV   CX,1
0416 80 FC 02     CMP   AH,2
0419 72 05        JB    GOT_IT
041B 26: 8A 5E 00 MOV  BL,ES:[BP]
041F 45          INC   BP
; SET CHARACTER WRITE AMOUNT TO ONE
; IS THE ATTRIBUTE IN THE STRING
; IF NOT THEN JUMP
; ELSE GET IT
; BUMP STRING POINTER

0420          GOT_IT:
0420 B4 09       MOV   AH,09
0422 CD 10       INT  10H
0424 07          POP   ES
0425 58          POP   AX
0426 5B          POP   BX
0427 59          POP   CX
; WRITE CHARACTER TO THE CRT
; RESTORE REGISTERS

0428 FE C2       INC  DL
042A 3A 16 004A R CMP  DL,BYTE PTR CRT_COLS
; INCREMENT COLUMN COUNTER
; IF COLS ARE WITHIN RANGE FOR
; THIS MODE THEN
; GOTO COLS SET

042E 72 14       JB   COLUMNS_SET
0430 FE C6       INC  DH
0432 2A D2       SUB  DL,DL
0434 80 FE 19    CMP  DH,25
0437 72 0B       JB   ROWS_SET
; BUMP ROW COUNTER BY ONE
; SET COLUMN COUNTER TO ZERO
; IF ROWS ARE < 25 THEN
; GOTO ROWS SET

0439 06          PUSH  ES
043A 50          PUSH  AX
043B 8B 0E0A     MOV  AX,0E0AH
043E CD 10       DEC  DH
0440 FE CE       DEC  DH
0442 58          POP   AX
0443 07          POP   ES
; DO SCROLL ONE LINE
; RESET ROW COUNTER TO 24
; RESTORE REG'S

0444          ROWS_SET:
0444          COLUMNS_SET:
0444 50          PUSH  AX
0445 B8 0200    MOV  AX,0200H
0448 CD 10       INT  10H
044A 58          POP   AX
044B E2 98       LOOP WRITE_CHAR
; SAVE WRITE STRING OPTION
; SET NEW CURSOR POSITION
; DO IT ONCE MORE UNTIL CX = ZERO

044D 5A          POP   DX
044E 3C 01       CMP  AL,1
0450 74 09       JE   DONE
0452 3C 03       CMP  AL,3
0454 74 05       JE   DONE
0456 B8 0200    MOV  AX,0200H
0459 CD 10       INT  10H
; RESTORE OLD CURSOR COORDINATES
; IF CURSOR WAS TO BE MOVED THEN
; WE'RE DONE
; ELSE RESTORE OLD CURSOR POSITION

045B          DONE:
045B E9 0144 R   JMP  VIDEO_RETURN
; RETURN TO CALLER

045E          WRITE_STRING  ENDP
page
;-----
; READ DOT -- WRITE DOT
; THESE ROUTINES WILL WRITE A DOT, OR READ THE
; DOT AT THE INDICATED LOCATION
; ENTRY --
; DX = ROW (0-199) (THE ACTUAL VALUE DEPENDS ON THE MODE)
; CX = COLUMN ( 0-639) ( THE VALUES ARE NOT RANGE CHECKED )
; AL = DOT VALUE TO WRITE (1,2 OR 4 BITS DEPENDING ON MODE,
; REQ'D FOR WRITE DOT ONLY, RIGHT JUSTIFIED)
; BIT 7 OF AL = 1 INDICATES XOR THE VALUE INTO THE LOCATION
; DS = DATA SEGMENT
; ES = REGEN SEGMENT
; EXIT
; AL = DOT VALUE READ, RIGHT JUSTIFIED, READ ONLY
;-----
ASSUME  CS:CODE,DS:DATA,ES:DATA
045E          READ_DOT  PROC  NEAR
045E E8 0492 R   CALL  R3
0461 26: 8A 04   MOV  AL,ES:[SI]
0464 22 C4       AND  AL,AH
0466 D2 E0       SHL  AL,CL
0468 8A CE       MOV  CL,DH
046A D2 C0       RDL  AL,CL
046C E9 0144 R   JMP  VIDEO_RETURN
046F          ENDP
; DETERMINE BYTE POSITION OF DOT
; GET THE BYTE
; MASK OFF THE OTHER BITS IN THE BYTE
; LEFT JUSTIFY THE VALUE
; GET NUMBER OF BITS IN RESULT
; RIGHT JUSTIFY THE RESULT
; RETURN FROM VIDEO IO

046F          READ_DOT  PROC  NEAR
046F          WRITE_DOT  PROC  NEAR
046F 50          PUSH  AX
0470 50          PUSH  AX
0471 E8 0492 R   CALL  R3
0474 D2 E8       SHR  AL,CL
0476 22 C4       AND  AL,AH
0478 26: 8A 0C   MOV  CL,ES:[SI]
047B 5B          POP   BX
047C F6 C3 80   TEST BL,80H
047F 75 0D       JNZ  R2
0481 F6 04       NOT  AH
0483 22 CC       AND  CL,AH
0485 0A C1       OR   OR AL,CL
; SAVE DOT VALUE
; TWICE
; DETERMINE BYTE POSITION OF THE DOT
; SHIFT TO SET UP THE BITS FOR OUTPUT
; STRIP OFF THE OTHER BITS
; GET THE CURRENT BYTE
; IS IT ON
; YES, XOR THE DOT
; SET THE MASK TO REMOVE THE INDICATED BITS
; FINISH_DOT
; RESTORE THE BYTE IN MEMORY

0487          R1:
0487 26: 88 04   MOV  ES:[SI],AL
048A 58          POP   AX
048B E9 0144 R   JMP  VIDEO_RETURN
; RETURN FROM VIDEO IO
; XOR_DOT
; EXCLUSIVE OR THE DOTS

048E          R2:
048E 32 C1       XOR  AL,CL

```

0490 EB F5
0492

```
                JMP      R1          ; FINISH UP THE WRITING  
WRITE_DOT     ENDP  
;-----  
; THIS SUBROUTINE DETERMINES THE REGEN BYTE LOCATION OF THE  
; INDICATED ROW COLUMN VALUE IN GRAPHICS MODE.  
; ENTRY --  
; DX = ROW VALUE (0-199)  
; CX = COLUMN VALUE (0-639)  
;-----  
; EXIT --  
; SI = OFFSET INTO REGEN BUFFER FOR BYTE OF INTEREST  
; AH = MASK TO STRIP OFF THE BITS OF INTEREST  
; CL = BITS TO SHIFT TO RIGHT JUSTIFY THE MASK IN AH  
; DH = # BITS IN RESULT  
;-----
```

0492
0492 53
0493 50

```
R3      PROC   NEAR  
        PUSH  BX          ; SAVE BX DURING OPERATION  
        PUSH  AX          ; WILL SAVE AL DURING OPERATION  
;-----  
; DETERMINE 1ST BYTE IN DICATED ROW BY MULTIPLYING ROW VALUE BY 40  
;----- ( LOW BIT OF ROW DETERMINES EVEN/ODD, 80 BYTES/ROW
```

0494 80 28
0496 52
0497 80 E2 FE
049A F6 E2
049C 5A
049D F6 C2 01
04A0 74 03
04A2 05 2000
04A5 8B F0
04A7 58
04A8 8B D1

```
        MOV   AL,40  
        PUSH  DX          ; SAVE ROW VALUE  
        AND  DL,0FEH     ; STRIP OFF ODD/EVEN BIT  
        MUL  DL          ; AX HAS ADDRESS OF 1ST BYTE OF INDICATED ROW  
        POP  DX          ; RECOVER IT  
        TEST DL,1        ; TEST FOR EVEN/ODD  
        JZ   R4          ; JUMP IF EVEN ROW  
        ADD  AX,2000H     ; OFFSET TO LOCATION OF ODD ROWS  
R4:     MOV   SI,AX       ; EVEN ROW  
        MOV  DI,SI       ; MOVE POINTER TO SI  
        POP  AX          ; RECOVER AL VALUE  
        MOV  DX,CX       ; COLUMN VALUE TO DX  
;-----
```

04AA BB 02C0
04AD B9 0302
04B0 80 3E 0049 R 06
04B5 72 06
04B7 BB 0180
04BA B9 0703

```
;----- DETERMINE GRAPHICS MODE CURRENTLY IN EFFECT  
; SET UP THE REGISTERS ACCORDING TO THE MODE  
; CH = MASK FOR LOW OF COLUMN ADDRESS ( 7/3 FOR HIGH/MED RES)  
; CL = # OF ADDRESS BITS IN COLUMN VALUE ( 3/2 FOR H/M)  
; BL = MASK TO SELECT BITS FROM POINTED BYTE (80H/COH FOR H/M)  
; BH = NUMBER OF VALID BITS IN POINTED BYTE ( 1/2 FOR H/M)
```

04BD
04BD 22 EA

```
        MOV  BX,2COH     ; SET PARMS FOR MED RES  
        MOV  CX,302H  
        CMP  CRT_MODE,6  
        JZ   R5          ; HANDLE IF MED ARES  
        MOV  BX,180H     ; SET PARMS FOR HIGH RES  
        MOV  CX,703H  
;-----  
; DETERMINE BIT OFFSET IN BYTE FROM COLUMN MASK  
R5:     AND  CH,DL        ; ADDRESS OF PEL WITHIN BYTE TO CH  
;-----  
; DETERMINE BYTE OFFSET FOR THIS LOCATION IN COLUMN
```

04BF 03 EA
04C1 03 F2
04C3 8A F7

```
        SHR  DX,CL       ; SHIFT BY CORRECT AMOUNT  
        ADD  SI,DX       ; INCREMENT THE POINTER  
        MOV  DH,BH       ; GET THE # OF BITS IN RESULT TO DH  
;-----  
; MULTIPLY BH (VALID BITS IN BYTE) BY CH (BIT OFFSET)
```

04C5 2A C9
04C7
04C7 D0 C8
04C9 02 CD
04CB FE CF
04CD 75 F8
04CF 8A E3
04D1 D2 EC
04D3 5B
04D4 C3
04D5

```
R6:     SUB  CL,CL        ; ZERO INTO STORAGE LOCATION  
        ROR  AL,1        ; LEFT JUSTIFY THE VALUE IN AL (FOR WRITE)  
        ADD  CL,CH       ; ADD IN THE BIT OFFSET VALUE  
        DEC  BH          ; LOOP CONTROL  
        JNZ  R6          ; ON EXIT, CL HAS SHIFT COUNT TO RESTORE BITS  
        MOV  AH,BL       ; GET MASK TO AH  
        SHR  AH,CL       ; MOVE THE MASK TO CORRECT LOCATION  
        POP  BX          ; RECOVER REG  
        RET              ; RETURN WITH EVERYTHING SET UP  
R3      ENDP  
;-----
```

04D5
04D5 8A D8
04D7 8B C1

```
GRAPHICS_UP  PROC   NEAR  
;-----  
; THIS ROUTINE SCROLLS UP THE INFORMATION ON THE CRT  
; ENTRY --  
; CH,CL = UPPER LEFT CORNER OF REGION TO SCROLL  
; DH,DL = LOWER RIGHT CORNER OF REGION TO SCROLL  
; BOTH OF THE ABOVE ARE IN CHARACTER POSITIONS  
; BH = FILL VALUE FOR BLANKED LINES  
; AL = # LINES TO SCROLL (AL=0 MEANS BLANK THE ENTIRE FIELD)  
; DS = DATA SEGMENT  
; ES = REGEN SEGMENT  
; EXIT --  
; NOTHING, THE SCREEN IS SCROLLED  
;-----
```

04D9 E8 0748 R
04DC 8B F8

```
        MOV  BL,AL       ; SAVE LINE COUNT IN BL  
        MOV  AX,CX       ; GET UPPER LEFT POSITION INTO AX REG  
;-----  
; USE CHARACTER SUBROUTINE FOR POSITIONING  
;----- ADDRESS RETURNED IS MULTIPLIED BY 2 FROM CORRECT VALUE  
CALL    GRAPH_POSN  
        MOV  D1,AX       ; SAVE RESULT AS DESTINATION ADDRESS  
;-----  
; DETERMINE SIZE OF WINDOW
```

04DE 2B D1
04E0 81 C2 0101
04E4 D0 E6
04E6 D0 E6

```
        SUB  DX,CX  
        ADD  DX,101H     ; ADJUST VALUES  
        SAL  DH,1        ; MULTIPLY # ROWS BY 4 SINCE 8 VERT DOTS/CHAR  
        SAL  DH,1        ; AND EVEN/ODD ROWS  
;-----  
; DETERMINE CRT MODE
```

04E8 80 3E 0049 R 06
04ED 73 04

```
        CMP  CRT_MODE,6  ; TEST FOR MEDIUM RES  
        JNC  R7          ; FIND_SOURCE
```

04EF D0 E2
04F1 D1 E7

```
;----- MEDIUM RES UP  
        SAL  DL,1        ; # COLUMNS * 2, SINCE 2 BYTES/CHAR  
        SAL  D1,1        ; OFFSET *2 SINCE 2 BYTES/CHAR  
;-----
```

04F3
04F3 06
04F4 1F
04F5 2A ED
04F7 D0 E3
04F9 D0 E3
04FB 74 2D
04FD 8A C3
04FF B4 50
0501 F6 E4
0503 8B F7
0505 03 F0
0507 8A E6

```
;----- DETERMINE THE SOURCE ADDRESS IN THE BUFFER  
R7:     MOV  DS,SI        ; FIND_SOURCE  
        PUSH ES          ; GET SEGMENTS BOTH POINTING TO REGEN  
        POP  DS  
        SUB  CH,CH       ; ZERO TO HIGH OF COUNT REG  
        SAL  BL,1        ; MULTIPLY NUMBER OF LINES BY 4  
        SAL  DL,1  
        JZ   R11         ; IF ZERO, THEN BLANK ENTIRE FIELD  
        MOV  AL,BL       ; GET NUMBER OF LINES IN AL  
        MOV  AH,80       ; 80 BYTES/ROW  
        MUL  AH          ; DETERMINE OFFSET TO SOURCE  
        MOV  SI,D1       ; SET UP SOURCE  
        ADD  SI,AX       ; ADD IN OFFSET TO IT  
        MOV  AH,DH       ; NUMBER OF ROWS IN FIELD
```

```

0509 2A E3                SUB    AH,BL                ; DETERMINE NUMBER TO MOVE

;----- LOOP THROUGH, MOVING ONE ROW AT A TIME, BOTH EVEN AND ODD FIELDS
R8:
050B                      CALL   R17                ; ROW LOOP
050C E8 058E R          SUB    S1,2000H-80        ; MOVE ONE ROW
050E 81 EE 1F80        SUB    D1,2000H-80        ; MOVE TO NEXT ROW
0512 81 EF 1F80        DEC    AH                ; NUMBER OF ROWS TO MOVE
0516 FC CC            JNZ    R8                ; CONTINUE TILL ALL MOVED
0518 75 F1

;----- FILL IN THE VACATED LINE(S)
R9:
051A                      MOV    AL,BH                ; CLEAR_ENTRY
051C 8A C7            MOV    AL,BH                ; ATTRIBUTE TO FILL WITH

R10:
051C E8 05A7 R          CALL   R18                ; CLEAR THAT ROW
051F 81 EF 1F80        SUB    D1,2000H-80        ; POINT TO NEXT LINE
0523 FE CB            DEC    BL                ; NUMBER OF LINES TO FILL
0525 75 F5            JNZ    R10                ; CLEAR_LOOP
0527 E9 0144 R          JMP    VIDEO_RETURN        ; EVERYTHING DONE

R11:
052A                      MOV    BL,DH                ; BLANK_FIELD
052A 8A DE            MOV    BL,DH                ; SET BLANK COUNT TO EVERYTHING IN FIELD
052C EB EC            JMP    R9                ; CLEAR THE FIELD
052E

GRAPHICS_UP             ENDP

;-----
; SCROLL DOWN
; THIS ROUTINE SCROLLS DOWN THE INFORMATION ON THE CRT
; ENTRY --
; CH,CL = UPPER LEFT CORNER OF REGION TO SCROLL
; DH,DL = LOWER RIGHT CORNER OF REGION TO SCROLL
; BOTH OF THE ABOVE ARE IN CHARACTER POSITIONS
; BH = FILL VALUE FOR BLANKED LINES
; AL = # LINES TO SCROLL (AL=0 MEANS BLANK THE ENTIRE FIELD)
; DS = DATA SEGMENT
; ES = REGEN SEGMENT
; EXIT --
; NOTHING, THE SCREEN IS SCROLLED
;-----

052E FD                GRAPHICS_DOWN PROC NEAR
052F 8A D8            STD                ; SET DIRECTION
0531 8B C2            MOV    BL,AL        ; SAVE LINE COUNT IN BL
                    MOV    AX,DX        ; GET LOWER RIGHT POSITION INTO AX REG

;----- USE CHARACTER SUBROUTINE FOR POSITIONING
;----- ADDRESS RETURNED IS MULTIPLIED BY 2 FROM CORRECT VALUE

0533 E8 0748 R          CALL   GRAPH_POSN        ; SAVE RESULT AS DESTINATION ADDRESS
0536 8B F8            MOV    DI,AX

;----- DETERMINE SIZE OF WINDOW

0538 2B D1            SUB    DX,CX
053A 81 C2 0101        ADD    DX,101H          ; ADJUST VALUES
053E D0 E6            SAL    DH,1            ; MULTIPLY # ROWS BY 4 SINCE 8 VERT DOTS/CHAR
0540 D0 E6            SAL    DH,1            ; AND EVEN/ODD ROWS

;----- DETERMINE CRT MODE

0542 80 3E 0049 R 06   CMP    CRT_MODE,6      ; TEST FOR MEDIUM RES
0547 73 05            JNC    R12             ; FIND_SOURCE_DOWN

;----- MEDIUM RES DOWN

0549 D0 E2            SAL    DL,1            ; # COLUMNS * 2, SINCE 2 BYTES/CHAR (OFFSET OK)
054B D1 E7            SAL    DI,1            ; OFFSET *2 SINCE 2 BYTES/CHAR
054D 47                INC    DI                ; POINT TO LAST BYTE

;----- DETERMINE THE SOURCE ADDRESS IN THE BUFFER
R12:
054E 06                POP    ES                ; FIND_SOURCE_DOWN
054F 1F                PUSH   DS                ; BOTH SEGMENTS TO REGEN
0550 2A ED            SUB    CH,CH            ; ZERO TO HIGH OF COUNT REG
0552 81 C7 00F0        ADD    DI,240           ; POINT TO LAST ROW OF PIXELS
0556 D0 E3            SAL    BL,1            ; MULTIPLY NUMBER OF LINES BY 4
0558 D0 E3            SAL    BL,1
055A 74 2E            JZ    R16               ; IF ZERO, THEN BLANK ENTIRE FIELD
055C 8A G3            MOV    AL,BL            ; GET NUMBER OF LINES IN AL
055E B4 90            MOV    AH,80            ; NO BYTES/ROW
0560 F6 E4            MUL    AH                ; DETERMINE OFFSET TO SOURCE
0562 8B F7            MOV    SI,DI            ; SET UP SOURCE
0564 2B F0            SUB    SI,AX            ; SUBTRACT THE OFFSET
0566 8A E6            MOV    AH,DH            ; NUMBER OF ROWS IN FIELD
0568 2A E3            SUB    AH,BL            ; DETERMINE NUMBER TO MOVE

;----- LOOP THROUGH, MOVING ONE ROW AT A TIME, BOTH EVEN AND ODD FIELDS
R13:
056A                      CALL   R17                ; ROW_LOOP_DOWN
056B E8 058E R          SUB    S1,2000H+80      ; MOVE ONE ROW
056D 81 EE 2050        SUB    D1,2000H+80      ; MOVE TO NEXT ROW
0571 81 EF 2050        DEC    AH                ; NUMBER OF ROWS TO MOVE
0575 FC CC            JNZ    R13                ; CONTINUE TILL ALL MOVED
0577 75 F1

;----- FILL IN THE VACATED LINE(S)
R14:
0579                      MOV    AL,BH                ; CLEAR_ENTRY_DOWN
057B                      MOV    AL,BH                ; ATTRIBUTE TO FILL WITH

R15:
057B E8 05A7 R          CALL   R18                ; CLEAR_LOOP_DOWN
057E 81 EF 2050        SUB    D1,2000H+80      ; CLEAR A ROW
0582 FE CB            DEC    BL                ; POINT TO NEXT LINE
0584 75 F5            JNZ    R15                ; NUMBER OF LINES TO FILL
0586 FC CC            CLD                    ; CLEAR_LOOP_DOWN
0587 E9 0144 R          JMP    VIDEO_RETURN        ; RESET THE DIRECTION FLAG
                    ; EVERYTHING DONE

R16:
058A                      MOV    BL,DH                ; BLANK_FIELD_DOWN
058A 8A DE            MOV    BL,DH                ; SET BLANK COUNT TO EVERYTHING IN FIELD
058C EB EB            JMP    R14                ; CLEAR THE FIELD
058E

GRAPHICS_DOWN         ENDP

;----- ROUTINE TO MOVE ONE ROW OF INFORMATION

R17 PROC NEAR
058E 8A CA            MOV    CL,DL            ; NUMBER OF BYTES IN THE ROW
0590 56                PUSH   S1                ;
0591 57                PUSH   DI                ; SAVE POINTERS
0592 F3 / AH          REP    MOVSB            ; MOVE THE EVEN FIELD
0594 5F                POP    DI                ;
0595 5E                POP    SI                ;
0596 81 C6 2000        ADD    SI,2000H          ;
059A 81 C7 2000        ADD    DI,2000H          ; POINT TO THE ODD FIELD
059E 56                PUSH   S1                ;
059F 57                PUSH   DI                ; SAVE THE POINTERS
05A0 8A CA            MOV    CL,DL            ; COUNT BACK
05A2 F3 / AH          REP    MOVSB            ; MOVE THE ODD FIELD
05A4 5F                POP    DI                ;
05A5 5E                POP    SI                ; POINTERS BACK
05A6 C3                RET                    ; RETURN TO CALLER

```

```

05A7                                R17    ENDP
;----- CLEAR A SINGLE ROW
05A7                                R18    PROC    NEAR
05A7      8A CA                      MOV    CL,DL      ; NUMBER OF BYTES IN FIELD
05A9      57                          PUSH   DI         ; SAVE POINTER
05AA      F3/ AA                      REP    STOSB     ; STORE THE NEW VALUE
05AC      5F                          POP    DI         ; POINTER BACK
05AD      81 C7 2000                  ADD    DI,2000H  ; POINT TO ODD FIELD
05B1      57                          PUSH   DI
05B2      8A CA                      MOV    CL,DL      ; FILL THE ODD FIELD
05B4      F3/ AA                      REP    STOSB
05B6      5F                          POP    DI
05B7      C3                          RET             ; RETURN TO CALLER
05B8

;-----
; GRAPHICS WRITE
; THIS ROUTINE WRITES THE ASCII CHARACTER TO THE CURRENT
; POSITION ON THE SCREEN.
; ENTRY --
; AL = CHARACTER TO WRITE
; BL = COLOR ATTRIBUTE TO BE USED FOR FOREGROUND COLOR
; IF BIT 7 IS SET, THE CHAR IS XOR'D INTO THE REGEN BUFFER
; (0 IS USED FOR THE BACKGROUND COLOR)
; CX = NUMBER OF CHARS TO WRITE
; DS = DATA SEGMENT
; ES = REGEN SEGMENT
; EXIT --
; NOTHING IS RETURNED
;
; GRAPHICS READ
; THIS ROUTINE READS THE ASCII CHARACTER AT THE CURRENT CURSOR
; POSITION ON THE SCREEN BY MATCHING THE DOTS ON THE SCREEN TO THE
; CHARACTER GENERATOR CODE POINTS
; ENTRY --
; NONE (0 IS ASSUMED AS THE BACKGROUND COLOR)
; EXIT --
; AL = CHARACTER READ AT THAT POSITION (0 RETURNED IF NONE FOUND)
;
; FOR BOTH ROUTINES, THE IMAGES USED TO FORM CHARS ARE CONTAINED IN ROM
; FOR THE 1ST 128 CHARS. TO ACCESS CHARS IN THE SECOND HALF, THE USER
; MUST INITIALIZE THE VECTOR AT INTERRUPT 1FH (LOCATION 0007CH) TO
; POINT TO THE USER SUPPLIED TABLE OF GRAPHIC IMAGES (8X8 BOXES).
; FAILURE TO DO SO WILL CAUSE IN STRANGE RESULTS
;-----
ASSUME CS:CODE,DS:DATA,ES:DATA
05B8      84 00                      GRAPHICS_WRITE PROC NEAR
05BA      50                          MOV    AX,0      ; ZERO TO HIGH OF CODE POINT
;----- DETERMINE POSITION IN REGEN BUFFER TO PUT CODE POINTS
05BB      E8 0745 R                    CALL   S26       ; FIND LOCATION IN REGEN BUFFER
05BE      8B F8                      MOV    DI,AX     ; REGEN POINTER IN DI
;----- DETERMINE REGION TO GET CODE POINTS FROM
05C0      58                          POP    AX        ; RECOVER CODE POINT
05C1      3C 80                      CMP    AL,80H   ; IS IT IN SECOND HALF
05C3      73 06                      JAE   S1        ; YES
;----- IMAGE IS IN FIRST HALF, CONTAINED IN ROM
05C5      BE 0000 E                    MOV    SI,OFFSET CRT_CHAR_GEN ; OFFSET OF IMAGES
05C8      0E                          PUSH   CS        ; SAVE SEGMENT ON STACK
05C9      EB 0F                          JMP    SHORT S2  ; DETERMINE_MODE
;----- IMAGE IS IN SECOND HALF, IN USER RAM
05CB      S1:                          ; EXTEND CHAR
05CC      2C 80                      SUB    AL,80H   ; ZERO ORIGIN FOR SECOND HALF
05CD      1E                          PUSH   DS        ; SAVE DATA POINTER
05CE      2B F6                      SUB    SI,S1    ; ESTABLISH VECTOR ADDRESSING
05D0      8E DE                      MOV    DS,S1
ASSUME DS:ABS0
05D2      C5 36 007C R                LDS    SI,EXT_PTR ; GET THE OFFSET OF THE TABLE
05D6      8C DA                      MOV    DI,DS    ; GET THE SEGMENT OF THE TABLE
ASSUME DS:DATA
05D8      1F                          POP    DS        ; RECOVER DATA SEGMENT
05D9      52                          PUSH   DX        ; SAVE TABLE SEGMENT ON STACK
;----- DETERMINE GRAPHICS MODE IN OPERATION
05DA      S2:                          ; DETERMINE_MODE
05DB      D1 E0                      SAL    AX,1     ; MULTIPLY CODE POINT
05DC      D1 E0                      SAL    AX,1     ; VALUE BY 8
05DE      03 F0                      ADD    SI,AX    ; SI HAS OFFSET OF DESIRED CODES
05E2      80 3E 0049 R 06             CMP    CRT_MODE,6
05E7      1F                          POP    DS        ; RECOVER TABLE POINTER SEGMENT
05E8      72 2C                      JC     S7        ; TEST FOR MEDIUM RESOLUTION MODE
;----- HIGH RESOLUTION MODE
05EA      S3:                          ; HIGH CHAR
05EB      57                          PUSH   DI        ; SAVE REGEN POINTER
05EC      56                          PUSH   SI        ; SAVE CODE POINTER
05ED      B6 04                      MOV    DH,4     ; NUMBER OF TIMES THROUGH LOOP
05EE      S4:                          ; GET BYTE FROM CODE POINTS
05EF      AC                          LODSB           ; SHOULD WE USE THE FUNCTION
05F2      F6 C3 80                    TEST   BL,80H  ; TO PUT CHAR IN
05F4      75 16                      JNZ   S6        ; STORE IN REGEN BUFFER
05F5      AC                          LODSB
05F6      S5:                          ;
05F7      26: 88 85 1FFF              MOV    ES:[DI+2000H-1],AL ; STORE IN SECOND HALF
05FB      83 C7 4F                    ADD    DI,79   ; MOVE TO NEXT ROW IN REGEN
05FE      FE CE                      DEC    DH       ; DONE WITH LOOP
0600      75 EC                      JNZ   S4
0602      5E                          POP    SI
0603      5F                          POP    DI        ; RECOVER REGEN POINTER
0604      47                          INC    DI        ; POINT TO NEXT CHAR POSITION
0605      E2 E3                      LOOP   S3        ; MORE CHARS TO WRITE
0607      E9 0144 R                    JMP    VIDEO_RETURN
060A      S6:                          ;
060D      26: 32 05                    XOR    AL,ES:[DI] ; EXCLUSIVE OR WITH CURRENT
060E      AA                          STOSB          ; STORE THE CODE POINT
060E      AC                          LODSB          ; AGAIN FOR ODD FIELD
060F      26: 32 85 1FFF              XOR    AL,ES:[DI+2000H-1]
0614      EB E0                          JMP    S5        ; BACK TO MAINSTREAM
;----- MEDIUM RESOLUTION WRITE
0616      S7:                          ; MED RES WRITE
0616      8A D3                      MOV    DL,BL   ; SAVE HIGH COLOR BIT
0618      D1 E7                      SAL    DI,1    ; OFFSET*2 SINCE 2 BYTES/CHAR

```



```

061A EB 06F1 R
061D
061D 57
061E 56
061F B6 04
0621
0621 AC
0622 E8 0706 R
0625 23 C3
0627 F6 C2 80
062A 74 07
062C 26: 32 25
062F 26: 32 45 01
0633
0633 26: 88 25
0636 26: 88 45 01
063A AC
063B E8 0706 R
063C 23 C3
0640 F6 C2 80
0643 74 0A
0645 26: 32 A5 2000
064A 26: 32 85 2001
064F
064F 26: 88 A5 2000
0654 26: 88 85 2001
0659 8C 7 50
065C FE CE
065E 75 C1
0660 5E
0661 5F
0662 47
0663 47
0664 E2 B7
0666 E9 0144 R
0669

S8: CALL S19 ; EXPAND BL TO FULL WORD OF COLOR
; MED_CHAR
; SAVE REGEN POINTER
; SAVE THE CODE POINTER
; NUMBER OF LOOPS
S9: LODSB ; GET CODE POINT
CALL S21 ; DOUBLE UP ALL THE BITS
AND AX,BX ; CONVERT THEM TO FOREGROUND COLOR ( 0 BACK )
TEST DL,80H ; IS THIS XOR FUNCTION
JZ S10 ; NO, STORE IT IN AS IT IS
XOR AH,ES:[DI] ; DO FUNCTION WITH HALF
XOR AL,ES:[DI+1] ; AND WITH OTHER HALF
S10: MOV ES:[DI],AH ; STORE FIRST BYTE
MOV ES:[DI+1],AL ; STORE SECOND BYTE
LODSB ; GET CODE POINT
CALL S21
AND AX,BX ; CONVERT TO COLOR
TEST DL,80H ; AGAIN, IS THIS XOR FUNCTION
JZ S11 ; NO, JUST STORE THE VALUES
XOR AH,ES:[DI+2000H] ; DO FUNCTION WITH FIRST HALF
XOR AL,ES:[DI+2001H] ; AND WITH SECOND HALF
S11: MOV ES:[DI+2000H],AH ; STORE IN SECOND PORTION OF BUFFER
MOV ES:[DI+2000H+1],AL ; POINT TO NEXT LOCATION
ADD DI,80
DEC DH
JNZ S9 ; KEEP GOING
POP SI ; RECOVER CODE POINTER
POP DI ; RECOVER REGEN POINTER
INC DI ; POINT TO NEXT CHAR POSITION
LOOP S8 ; MORE TO WRITE
JMP VIDEO_RETURN
GRAPHICS_WRITE ENDP
;-----
; GRAPHICS READ
GRAPHICS_READ PROC NEAR
CALL S26 ; CONVERTED TO OFFSET IN REGEN
MOV SI,AX ; SAVE IN SI
SUB SP,8 ; ALLOCATE SPACE TO SAVE THE READ CODE POINT
MOV BP,SP ; POINTER TO SAVE AREA
;----- DETERMINE GRAPHICS MODES
0673 80 3E 0049 R 06
0678 06
0679 1F
067A 72 1A
CMP CRT_MODE,6 ;
PUSH ES ;
POP DS ; POINT TO REGEN SEGMENT
JC S13 ; MEDIUM RESOLUTION READ
;----- HIGH RESOLUTION READ
;----- GET VALUES FROM REGEN BUFFER AND CONVERT TO CODE POINT
067C B6 04
067E
067E 8A 04
0680 88 46 00
0683 45
0684 8A 84 2000
0688 88 46 00
068B 45
068C 83 C6 50
068F FE CE
0691 75 E8
0693 EB 17 90
MOV DH,4 ; NUMBER OF PASSES
S12: MOV AL,[SI] ; GET FIRST BYTE
MOV [BP],AL ; SAVE IN STORAGE AREA
INC BP ; NEXT LOCATION
MOV AL,[SI+2000H] ; GET LOWER REGION BYTE
MOV [BP],AL ; ADJUST AND STORE
INC BP
DEC SI,80 ; POINTER INTO REGEN
ADD DH ; LOOP CONTROL
JNZ S12 ; DO IT SOME MORE
JMP S15 ; GO MATCH THE SAVED CODE POINTS
;----- MEDIUM RESOLUTION READ
0696 D1 E6
0698 B6 04
069A
069A E8 0728 R
069D 81 C6 2000
06A1 E8 0728 R
06A4 81 EE 1F80
06A8 FE CE
06AA 75 EE
S13: SAL SI,1 ; MED RES READ
MOV DH,4 ; OFFSET#2 SINCE 2 BYTES/CHAR
; NUMBER OF PASSES
S14: CALL S23 ; GET PAIR BYTES FROM REGEN INTO SINGLE SAVE
ADD SI,2000H ; GO TO LOWER REGION
CALL S23 ; GET THIS PAIR INTO SAVE
SI,2000H-80 ; ADJUST POINTER BACK INTO UPPER
DEC DH ;
JNZ S14 ; KEEP GOING UNTIL ALL 8 DONE
;----- SAVE AREA HAS CHARACTER IN IT, MATCH IT
06AC
06AC BF 0000 E
06AF 0E
06B0 07
06B1 83 ED 08
06B4 8B F5
06B6 FC
06B7 B0 00
06B9
06B9 16
06BA 1F
06BB BA 0080
06BE
06BE 56
06BF 57
06C0 B9 0008
06C3 F3 A6
06C5 8A 1E 0017 R
06C9 5F
06CA 5E
06CB 74 1E
06CD FE C0
06CF 83 C7 08
06D2 4A
06D3 75 E9
S15: MOV DI,OFFSET CRT_CHAR_GEN ; ESTABLISH ADDRESSING
; FIND_CHAR
PUSH CS ;
POP ES ; CODE POINTS IN CS
SUB BP,8 ; ADJUST POINTER TO BEGINNING OF SAVE AREA
MOV SI,BP
CLD ; ENSURE DIRECTION
MOV AL,0 ; CURRENT CODE POINT BEING MATCHED
S16: PUSH SS ; ESTABLISH ADDRESSING TO STACK
POP DS ;
MOV DX,128 ; NUMBER TO TEST AGAINST
S17: PUSH SI ; SAVE SAVE AREA POINTER
PUSH DI ; SAVE CODE POINTER
MOV CX,8 ; NUMBER OF BYTES TO MATCH
REPE CMPSB ; COMPARE THE 8 BYTES
MOV BL,KB_FLAG ; READ ANY BYTE OF STORAGE
POP DI ; RECOVER THE POINTERS
POP SI
JZ S18 ; IF ZERO FLAG SET, THEN MATCH OCCURRED
INC AL ; NO MATCH, MOVE ON TO NEXT
ADD DI,8 ; NEXT CODE POINT
LOOP DX ; LOOP CONTROL
JNZ S17 ; DO ALL OF THEM
;----- CHAR NOT MATCHED, MIGHT BE IN USER SUPPLIED SECOND HALF
06D5 3C 00
06D7 74 12
06D9 2B C0
06DB 8E 08
CMP AL,0 ; AL<> 0 IF ONLY 1ST HALF SCANNED
JE S18 ; IF = 0, THEN ALL HAS BEEN SCANNED
SUB AX,AX
MOV DS,AX
ASSUME DS:ABS0
LES DI,EXT_PTR ; GET POINTER
MOV AX,ES ; SEE IF THE POINTER REALLY EXISTS
OR AX,DI ; IF ALL 0, THEN DOESN'T EXIST
JZ S18 ; NO SENSE LOOKING
MOV AL,128 ; ORIGIN FOR SECOND HALF
JMP S16 ; GO BACK AND TRY FOR IT
ASSUME DS:DATA
;----- CHARACTER IS FOUND ( AL=0 IF NOT FOUND )
06EB
06EB 83 C4 08
06EE E9 0144 R
ADD SP,8 ; READJUST THE STACK, THROW AWAY SAVE
JMP VIDEO_RETURN ; ALL DONE

```

06F1

GRAPHICS_READ ENDP

```

; EXPAND_MED_COLOR
; THIS ROUTINE EXPANDS THE LOW 2 BITS IN BL TO
; FILL THE ENTIRE BX REGISTER
; ENTRY --
; BL = COLOR TO BE USED ( LOW 2 BITS )
; EXIT --
; BX = COLOR TO BE USED ( 8 REPLICATIONS OF THE 2 COLOR BITS )

```

06F1
06F1 80 E3 03
06F4 BA C3
06F6 51
06F7 B9 0003
06FA
06FA D0 E0
06FC D0 E0
06FE DA D8
0700 E2 F8
0702 8A FB
0704 59
0705 C3
0706

```

S19 PROC NEAR
    AND BL,3 ; ISOLATE THE COLOR BITS
    MOV AL,BL ; COPY TO AL
    PUSH CX ; SAVE REGISTER
    MOV CX,3 ; NUMBER OF TIMES TO DO THIS
S20:
    SAL AL,1 ; LEFT SHIFT BY 2
    OR BL,AL ; ANOTHER COLOR VERSION INTO BL
    LOOP S20 ; FILL ALL OF BL
    MOV BH,BL ; FILL UPPER PORTION
    POP CX ; REGISTER BACK
    RET ; ALL DONE
S19 ENDP

```

```

; EXPAND BYTE
; THIS ROUTINE TAKES THE BYTE IN AL AND DOUBLES ALL
; OF THE BITS, TURNING THE 8 BITS INTO 16 BITS.
; THE RESULT IS LEFT IN AX

```

0706
0706 52
0707 51
0708 53
0709 2B D2
070B B9 0001
070E
070E 8B D8
0710 23 D9
0712 0B D3
0714 D1 E0
0716 D1 E1
0718 8B D8
071A 23 D9
071C 0B D3
071E D1 E1
0720 73 EC
0722 8B C2
0724 5B
0725 59
0726 5A
0727 C3
0728

```

S21 PROC NEAR
    PUSH DX ; SAVE REGISTERS
    PUSH CX
    PUSH BX
    SUB DX,DX ; RESULT REGISTER
    MOV CX,1 ; MASK REGISTER
S22:
    MOV BX,AX ; BASE INTO TEMP
    AND BX,CX ; USE MASK TO EXTRACT A BIT
    OR DX,BX ; PUT INTO RESULT REGISTER
    SHL AX,1
    SHL CX,1 ; SHIFT BASE AND MASK BY 1
    MOV BX,AX ; BASE TO TEMP
    AND BX,CX ; EXTRACT THE SAME BIT
    OR DX,BX ; PUT INTO RESULT
    SHL CX,1 ; SHIFT ONLY MASK NOW, MOVING TO NEXT BASE
    JNC S22 ; USE MASK BIT COMING OUT TO TERMINATE
    MOV AX,DX ; RESULT TO PARM REGISTER
    POP BX
    POP CX ; RECOVER REGISTERS
    POP DX
    RET ; ALL DONE
S21 ENDP

```

```

; MED_READ_BYTE
; THIS ROUTINE WILL TAKE 2 BYTES FROM THE REGEN BUFFER,
; COMPARE AGAINST THE CURRENT FOREGROUND COLOR, AND PLACE
; THE CORRESPONDING ON/OFF BIT PATTERN INTO THE CURRENT
; POSITION IN THE SAVE AREA
; ENTRY --
; SI_DS = POINTER TO REGEN AREA OF INTEREST
; BX = EXPANDED FOREGROUND COLOR
; BP = POINTER TO SAVE AREA
; EXIT --
; BP IS INCREMENT AFTER SAVE

```

0728
0728 8A 24
072A 8A 44 01
072D B9 C000
0730 B2 00
0732
0732 85 C1
0734 F8
0735 74 01
0737 F9
0738 D0 D2
073A D1 E9
073C D1 E9
073E 73 F2
0740 86 56 00
0743 45
0744 C3
0745

```

S23 PROC NEAR
    MOV AH,[SI] ; GET FIRST BYTE
    MOV AL,[SI+1] ; GET SECOND BYTE
    MOV CX,0C000H ; 2 BIT MASK TO TEST THE ENTRIES
    MOV DL,0 ; RESULT REGISTER
S24:
    TEST AX,CX ; IS THIS SECTION BACKGROUND?
    CLC ; CLEAR CARRY IN HOPES THAT IT IS
    JZ S25 ; IF ZERO, IT IS BACKGROUND
    STC ; WASH!, SO SET CARRY
    RCL DL,1 ; MOVE THAT BIT INTO THE RESULT
    SHR CX,1
    SHR CX,1 ; MOVE THE MASK TO THE RIGHT BY 2 BITS
    JNC S24 ; DO IT AGAIN IF MASK DIDN'T FALL OUT
    MOV [BP],DL ; STORE RESULT IN SAVE AREA
    INC BP ; ADJUST POINTER
    RET ; ALL DONE
S23 ENDP

```

```

; V4_POSITION
; THIS ROUTINE TAKES THE CURSOR POSITION CONTAINED IN
; THE MEMORY LOCATION, AND CONVERTS IT INTO AN OFFSET
; INTO THE REGEN BUFFER, ASSUMING ONE BYTE/CHAR.
; FOR MEDIUM RESOLUTION GRAPHICS, THE NUMBER MUST
; BE DOUBLED.
; ENTRY -- NO REGISTERS, MEMORY LOCATION CURSOR_POSN IS USED
; EXIT --
; AX CONTAINS OFFSET INTO REGEN BUFFER

```

0745
0745 A1 0050 R
0748
0748 53
0749 8B D8
074B BA C4
074D F6 26 004A R
0751 D1 E0
0753 D1 E0
0755 2A FF
0757 03 C3
0759 5B
075A C3
075B

```

S26 PROC NEAR
    MOV AX,CURSOR_POSN ; GET CURRENT CURSOR
    MOV LABEL NEAR GRAPH_POSN ;
    PUSH BX ; SAVE REGISTER
    MOV BX,AX ; SAVE A COPY OF CURRENT CURSOR
    MOV AX,AX ; GET ROWS TO AL
    MUL BYTE PTR CRT_COLS ; MULTIPLY BY BYTES/COLUMN
    SHL AX,1 ; MULTIPLY * 4 SINCE 4 ROWS/BYTE
    SUB BH,BH ; ISOLATE COLUMN VALUE
    ADD AX,BX ; DETERMINE OFFSET
    POP BX ; RECOVER POINTER
    RET ; ALL DONE
S26 ENDP

```

```

; WRITE_TTY
; THIS INTERFACE PROVIDES A TELETYPE LIKE INTERFACE TO THE
; VIDEO CARD. THE INPUT CHARACTER IS WRITTEN TO THE CURRENT
; CURSOR POSITION, AND THE CURSOR IS MOVED TO THE NEXT POSITION.
; IF THE CURSOR LEAVES THE LAST COLUMN OF THE FIELD, THE COLUMN
; IS SET TO ZERO, AND THE ROW VALUE IS INCREMENTED. IF THE ROW
; ROW VALUE LEAVES THE FIELD, THE CURSOR IS PLACED ON THE LAST ROW,
; FIRST COLUMN, AND THE ENTIRE SCREEN IS SCROLLED UP ONE LINE.
; WHEN THE SCREEN IS SCROLLED UP, THE ATTRIBUTE FOR FILLING THE
; NEWLY BLANKED LINE IS READ FROM THE CURSOR POSITION ON THE PREVIOUS
; LINE BEFORE THE SCROLL, IN CHARACTER MODE. IN GRAPHICS MODE,
; THE 0 COLOR IS USED.
; ENTRY --
; (AH) = CURRENT CRT MODE
; (AL) = CHARACTER TO BE WRITTEN
; NOTE THAT BACK SPACE, CAR RET, BELL AND LINE FEED ARE HANDLED

```

```

; AS COMMANDS RATHER THAN AS DISPLAYABLE GRAPHICS
; (BL) = FOREGROUND COLOR FOR CHAR WRITE IF CURRENTLY IN A GRAPHICS MODE
; EXIT --
; ALL REGISTERS SAVED
-----
ASSUME CS:CODE,DS:DATA
WRITE_TTY PROC NEAR
    PUSH AX          ; SAVE REGISTERS
    PUSH AX          ; SAVE CHAR TO WRITE
    MOV AH,3
    MOV BH,ACTIVE_PAGE ; GET CURRENT PAGE SETTING
    INT 10H          ; READ THE CURRENT CURSOR POSITION
    POP AX           ; RECOVER CHAR
;---- DX NOW HAS THE CURRENT CURSOR POSITION
    CMP AL,8         ; IS IT A BACKSPACE
    JE U8            ; BACK_SPACE
    CMP AL,0DH       ; IS IT CARRIAGE RETURN
    JE GRR_RET       ; GRR_RET
    CMP AL,0AH       ; IS IT A LINE FEED
    JE U10           ; LINE_FEED
    CMP AL,07H      ; IS IT A BELL
    JE U11           ; BELL
;---- WRITE THE CHAR TO THE SCREEN
    MOV AH,10        ; WRITE CHAR ONLY
    MOV CX,1         ; ONLY ONE CHAR
    INT 10H         ; WRITE THE CHAR
;---- POSITION THE CURSOR FOR NEXT CHAR
    INC DL           ;
    CMP DL,BYTE PTR CRT_COLS ; TEST FOR COLUMN OVERFLOW
    JNZ U7          ; SET_CURSOR
    MOV DL,0        ; COLUMN FOR CURSOR
    CMP DH,24       ;
    JNZ U6          ; SET_CURSOR_INC
;---- SCROLL REQUIRED
U1:
    MOV AH,2        ;
    INT 10H        ; SET THE CURSOR
;---- DETERMINE VALUE TO FILL WITH DURING SCROLL
    MOV AL,CRT_MODE ; GET THE CURRENT MODE
    CMP AL,4        ;
    JC U2           ; READ-CURSOR
    CMP AL,7        ;
    MOV BH,0        ; FILL WITH BACKGROUND
    JNE U3          ; SCROLL-UP
; READ-CURSOR
    MOV AH,8        ;
    INT 10H        ; READ CHAR/ATTR AT CURRENT CURSOR
    MOV BH,AH      ; STORE IN BH
; SCROLL-UP
    MOV AX,601H    ; SCROLL ONE LINE
    SUB CX,CX      ; UPPER LEFT CORNER
    MOV DH,24     ; LOWER RIGHT ROW
    MOV DL,BYTE PTR CRT_COLS ; LOWER RIGHT COLUMN
    DEC DL
; VIDEO-CALL-RETURN
    INT 10H       ; SCROLL UP THE SCREEN
; TTY-RETURN
    POP AX        ; RESTORE THE CHARACTER
    JMP VIDEO_RETURN ; RETURN TO CALLER
; SET-CURSOR-INC
    INC DH        ; NEXT ROW
; SET-CURSOR
    MOV AH,2     ;
    JMP U4       ; ESTABLISH THE NEW CURSOR
;---- BACK SPACE FOUND
U8:
    CMP DL,0    ; ALREADY AT END OF LINE
    JE U7       ; SET_CURSOR
    DEC DL      ; NO -- JUST MOVE IT BACK
    JMP U7     ; SET_CURSOR
;---- CARRIAGE RETURN FOUND
U9:
    MOV DL,0    ; MOVE TO FIRST COLUMN
    JMP U7     ; SET_CURSOR
;---- LINE FEED FOUND
U10:
    CMP DH,24  ; BOTTOM OF SCREEN
    JNE U6     ; YES, SCROLL THE SCREEN
    JMP U1     ; NO, JUST SET THE CURSOR
;---- BELL FOUND
U11:
    MOV BL,2   ; SET UP COUNT FOR BEEP
    CALL BEEP ; SOUND THE POD BELL
    JMP U5     ; TTY_RETURN
WRITE_TTY ENDP
; LIGHT PEN
; THIS ROUTINE TESTS THE LIGHT PEN SWITCH AND THE LIGHT
; PEN TRIGGER. IF BOTH ARE SET, THE LOCATION OF THE LIGHT
; PEN IS DETERMINED. OTHERWISE, A RETURN WITH NO INFORMATION
; IS MADE.
; ON EXIT:
; (AH) = 0 IF NO LIGHT PEN INFORMATION IS AVAILABLE
; BX,CX,DX ARE DESTROYED
; (AH) = 1 IF LIGHT PEN IS AVAILABLE
; (DH,DL) = ROW,COLUMN OF CURRENT LIGHT PEN POSITION
; (CH) = RASTER POSITION
; (BX) = BEST GUESS AT PIXEL HORIZONTAL POSITION
-----
ASSUME CS:CODE,DS:DATA
SUBTRACT_TABLE
V1 LABEL BYTE
    DB 3,3,5,5,3,3,3,4 ;
;----
READ_LPEN PROC NEAR

```

```

;----- WAIT FOR LIGHT PEN TO BE DEPRESSED
07DF B4 00          MOV     AH,0          ; SET NO LIGHT PEN RETURN CODE
07E1 8B 16 0063 R  MOV     DX,ADDR_6845 ; GET BASE ADDRESS OF 6845
07E3 83 C2 06       ADD     DX,6          ; POINT TO STATUS REGISTER
07E8 EC           IN     AL,DX         ; GET STATUS REGISTER
07E9 A8 04         TEST    AL,4         ; TEST LIGHT PEN SWITCH
07EB 74 03       JZ     V6_A         ; GO IF YES
07ED E9 0872 R     JMP     V6           ; NOT SET, RETURN

;----- NOW TEST FOR LIGHT PEN TRIGGER
07F0 A8 02       V6_A: TEST    AL,2         ; TEST LIGHT PEN TRIGGER
07F2 75 03       JNZ    V7A         ; RETURN WITHOUT RESETTING TRIGGER
07F4 E9 087C R     JMP     V7

;----- TRIGGER HAS BEEN SET, READ THE VALUE IN
07F7 B4 10       V7A: MOV     AH,16        ; LIGHT PEN REGISTERS ON 6845

;----- INPUT REGS POINTED TO BY AH, AND CONVERT TO ROW COLUMN IN DX
07F9 8B 16 0063 R  MOV     DX,ADDR_6845 ; ADDRESS REGISTER FOR 6845
07FD 8A C4       MOV     AL,AH        ; REGISTER TO READ
07FF EE 00       OUT    DX,AL        ; SET IT UP
0800 EB 00       JMP     SHORT $+2    ; IO DELAY
0802 42         INC    DX           ; DATA REGISTER
0803 EC         IN     AL,DX        ; GET THE VALUE
0804 8A E8       MOV     CH,AL       ; SAVE IN CX
0806 4A         DEC    DX           ; ADDRESS REGISTER
0807 FE C4       INC    AH           ;
0809 8A C4       MOV     AL,AH        ; SECOND DATA REGISTER
080B EE 00       OUT    DX,AL        ;
080C 42         INC    DX           ; POINT TO DATA REGISTER
080D EB 00       JMP     SHORT $+2    ; IO DELAY
080F EC         IN     AL,DX        ; GET SECOND DATA VALUE
0810 8A E5       MOV     AH,CH       ; AX HAS INPUT VALUE

;----- AX HAS THE VALUE READ IN FROM THE 6845
0812 8A 1E 0049 R  MOV     BL,CRT_MODE ;
0816 2A FF       SUB     BH,BH        ; MODE VALUE TO BX
0818 2E 8A 9F 07D7 R MOV     BL,CS-VI[BX] ; DETERMINE AMOUNT TO SUBTRACT
081D 2B C3       SUB     AX,BX        ; TAKE IT AWAY
081F 8B 1E 004E R  MOV     BX,CRT_START ;
0823 01 EB       SHR    BX,1         ; CONVERT TO CORRECT PAGE ORIGIN
0825 2B C3       SUB     AX,BX        ; IF POSITIVE, DETERMINE MODE
0827 79 02       JNS    V2           ; <0 PLAYS AS 0
0829 2B C0       SUB     AX,AX

;----- DETERMINE MODE OF OPERATION
082B B1 03       V2:  MOV     CL,3        ; DETERMINE_MODE
082B 81 03       SET    #8 SHIFT COUNT
082D 80 3E 0049 R 04 CMP     CRT_MODE,4  ; DETERMINE IF GRAPHICS OR ALPHA
0832 72 2A       JB     V4           ; ALPHA_PEN
0834 80 3E 0049 R 07 CNP     CRT_MODE,7  ;
0839 74 23       JE     V4           ; ALPHA_PEN

;----- GRAPHICS MODE
083B B2 28       MOV     DL,40       ; DIVISOR FOR GRAPHICS
083D F6 F2       DIV    DL           ; DETERMINE ROW(AL) AND COLUMN(AH)
; AL RANGE 0-99, AH RANGE 0-39

;----- DETERMINE GRAPHIC ROW POSITION
083F 8A E8       MOV     CH,AL       ; SAVE ROW VALUE IN CH
0841 02 ED       ADD    CH,CH        ; *2 FOR EVEN/ODD FIELD
0843 8A DC       MOV     BL,AH       ; COLUMN VALUE TO BX
0845 2A FF       SUB     BH,BH        ; MULTIPLY BY 8 FOR MEDIUM RES
0847 80 3E 0049 R 06 CMP     CRT_MODE,6  ; DETERMINE MEDIUM OR HIGH RES
084C 75 04       JNE    V3           ; NOT HIGH_RES
084E B1 08       MOV     CL,4        ; SHIFT VALUE FOR HIGH RES
0850 00 E4       SAL    AH,1         ; COLUMN VALUE TIMES 2 FOR HIGH RES
0852 D3 E3       V3:  SHL    BX,CL       ; NOT HIGH_RES
0852 D3 E3       ; MULTIPLY *16 FOR HIGH RES

;----- DETERMINE ALPHA CHAR POSITION
0854 8A D4       MOV     DL,AH       ; COLUMN VALUE FOR RETURN
0856 8A F0       MOV     DH,AL       ; ROW VALUE
0858 00 EE       SHR    DH,1         ; DIVIDE BY 4
085A 80 3E 0049 R 05 CNP     DH,1         ; FOR VALUE IN 0-24 RANGE
085C EB 12       JMP     SHORT V5    ; LIGHT_PEN_RETURN_SET

;----- ALPHA MODE ON LIGHT PEN
085E F6 36 004A R  V4:  DIV    BYTE PTR CRT_COLS ; ALPHA_PEN
0862 8A F0       MOV     DH,AL       ; DETERMINE ROW,COLUMN VALUE
0864 8A D4       MOV     DL,AH       ; ROWS TO DH
0866 D2 E0       SAL    AL,CL        ; COLS TO DL
0868 8A E8       MOV     CH,AL       ; MULTIPLY ROWS * 8
086A 8A DC       MOV     BL,AH       ; GET RASTER VALUE TO RETURN REG
086C 32 FF       XOR    BH,BH        ; COLUMN VALUE
086E D3 E3       SAL    BX,CL        ; TO BX
0870 B4 01       V5:  MOV     AH,1        ; LIGHT_PEN_RETURN_SET
0872 52         PUSH    DX           ; INDICATE EVERYTHING SET
0873 8B 16 0063 R  V6:  MOV     DX,ADDR_6845 ; LIGHT_PEN_RETURN
0877 83 C2 07       ADD    DX,7         ; SAVE RETURN VALUE (IN CASE)
087A EE         OUT    DX,AL        ; GET BASE ADDRESS
087B 5A         POP    DX           ; POINT TO RESET PARM
087C 5D         POP    BP           ; ADDRESS, NOT DATA, IS IMPORTANT
087D 5F         POP    D1          ; RECOVER VALUE
087E 5E         POP    SI          ; RETURN_NO_RESET
087F 1F         POP    DS          ; DISCARD SAVED BX,CX,DX
0880 1F         POP    DS
0881 1F         POP    DS
0882 1F         POP    DS
0883 07         POP    ES
0884 CF         IRET
0885 READ_LPEN     ENDP
0885 CODE        ENDS
0885 END

```

0000

```

TITLE 11/22/83 BIOS
.LIST
INCLUDE SEGMENT.SRC
CODE SEGMENT BYTE PUBLIC
C C C
EXTRN C8042:NEAR
EXTRN OBF_02:NEAR
EXTRN DDS:NEAR
EXTRN PRT_HEX:NEAR
EXTRN D1:NEAR
EXTRN D2:NEAR
EXTRN P_MSG:NEAR
EXTRN D2A:NEAR
EXTRN PRT_SEG:NEAR
EXTRN PROC_SHUTDOWN:NEAR
EXTRN CM3:NEAR
EXTRN E_MSG:NEAR

PUBLIC MEMORY_SIZE_DETERMINE_1
PUBLIC EQUIPMENT_1
PUBLIC NMI_INT_1
PUBLIC SET_TOD

```

```

----- INT 12 -----
MEMORY_SIZE_DETERMINE
THIS ROUTINE RETURNS THE AMOUNT OF MEMORY IN THE
SYSTEM AS DETERMINED BY THE POST ROUTINES.
NOTE THAT THE SYSTEM MAY NOT BE ABLE TO USE I/O MEMORY
UNLESS THERE IS A FULL COMPLEMENT OF 512K BYTES ON THE
PLANAR.
INPUT
NO REGISTERS
THE MEMORY SIZE VARIABLE IS SET DURING POWER ON
DIAGNOSTICS ACCORDING TO THE FOLLOWING ASSUMPTIONS:
1. CONFIGURATION RECORD IN NON-VOLATILE MEMORY
EQUALS THE ACTUAL MEMORY SIZE INSTALLED.
2. ALL INSTALLED MEMORY IS FUNCTIONAL. IF THE
MEMORY TEST DURING POST INDICATES LESS, THEN THIS
VALUE BECOMES THE DEFAULT. IF NON-VOLATILE MEMORY
IS NOT VALID (NOT INITIALIZED OR BATTERY FAILURE)
THEN ACTUAL MEMORY DETERMINED BECOMES THE DEFAULT.
3. ALL MEMORY FROM 0 TO 640K MUST BE CONTIGUOUS.
OUTPUT
(AK) = NUMBER OF CONTIGUOUS 1K BLOCKS OF MEMORY
-----
ASSUME CS:CODE,DS:DATA

```

```

0000 FB
0001 1E
0002 E8 0000 E
0005 A1 0013 R
0008 1F
0009 CF
000A

```

```

MEMORY_SIZE_DETERMINE_1 PROC FAR ;
STI DS ; INTERRUPTS BACK ON
PUSH DS ; SAVE SEGMENT
CALL DDS ; ESTABLISH ADDRESSING
MOV AX, MEMORY_SIZE ; GET VALUE
POP DS ; RECOVER SEGMENT
IRET ; RETURN TO CALLER
MEMORY_SIZE_DETERMINE_1 ENDP

```

```

----- INT 11 -----
EQUIPMENT_DETERMINATION
THIS ROUTINE ATTEMPTS TO DETERMINE WHAT OPTIONAL
DEVICES ARE ATTACHED TO THE SYSTEM.
INPUT
NO REGISTERS
THE EQUIP_FLAG VARIABLE IS SET DURING THE POWER ON
DIAGNOSTICS USING THE FOLLOWING HARDWARE ASSUMPTIONS:
PORT 3FA = INTERRUPT ID REGISTER OF 8250 (PRIMARY)
2FA = INTERRUPT ID REGISTER OF 8250 (SECONDARY)
BITS 7-3 ARE ALWAYS 0
PORT 378 = OUTPUT PORT OF PRINTER (PRIMARY)
278 = OUTPUT PORT OF PRINTER (SECONDARY)
3BC = OUTPUT PORT OF PRINTER (MONO-PRINTER)
OUTPUT
(AK) IS SET, BIT SIGNIFICANT, TO INDICATE ATTACHED I/O
BIT 15,14 = NUMBER OF PRINTERS ATTACHED
BIT 13,12 NOT USED
BIT 11,10,9 = NUMBER OF RS232 CARDS ATTACHED
BIT 8 = NOT USED
BIT 7,6 = NUMBER OF DISKETTE DRIVES
00=1, 01=2 ONLY IF BIT 0 = 1
BIT 5,4 = INITIAL VIDEO MODE
00 - UNUSED
01 - 40X25 BW USING COLOR CARD
10 - 80X25 BW USING COLOR CARD
11 - 80X25 BW USING BW CARD
BIT 3 = NOT USED
BIT 2 = NOT USED
BIT 1 = MATH COPROCESSOR
BIT 0 = 1 (IPL DISKETTE INSTALLED)
NO OTHER REGISTERS AFFECTED
-----
ASSUME CS:CODE,DS:DATA

```

```

000A
000A FB
000B 1E
000C E8 0000 E
000F A1 0010 R
0012 1F
0013 CF
0014

```

```

EQUIPMENT_1 PROC FAR ; >>> ENTRY POINT FOR ORG OF 840H
STI DS ; INTERRUPTS BACK ON
PUSH DS ; SAVE SEGMENT REGISTER
CALL DDS ; ESTABLISH ADDRESSING
MOV AX, EQUIP_FLAG ; GET THE CURRENT SETTINGS
POP DS ; RECOVER SEGMENT
IRET ; RETURN TO CALLER
EQUIPMENT_1 ENDP

```

```

----- INT 2 -----
NON-MASKABLE_INTERRUPT_ROUTINE (REAL MODE)
THIS ROUTINE WILL PRINT A "PARITY CHECK 1 OR 2" MESSAGE
AND ATTEMPT TO FIND THE STORAGE LOCATION CONTAINING THE
BAD PARITY. IF FOUND, THE SEGMENT ADDRESS WILL BE
PRINTED. IF NO PARITY ERROR CAN BE FOUND (INTERMITTENT
READ PROBLEM) ???<-WILL BE PRINTED WHERE THE ADDRESS
WOULD NORMALLY GO.
PARITY_CHECK_1 = PLANAR BOARD MEMORY FAILURE.
PARITY_CHECK_2 = OFF PLANAR BOARD MEMORY FAILURE.
-----

```

```

0014
0014 50
0015 E4 80
0017 FE C0
0019 EB 00
001B E6 80
001D E4 61
001F A8 C0

```

```

NMI_INT_1 PROC NEAR
ASSUME DS:DATA
PUSH AX ; SAVE ORIG CONTENTS OF AX
IN AL, MFG_PORT ; INCREMENT NMI COUNT
INC AL
JMP SHORT $+2 ; IN DELAY
OUT MFG_PORT, AL ; SET COUNT
IN AL, PORT_B
TEST AL, PARITY_ERR ; PARITY CHECK?

```

SECTION 5

```

0021 8A E0                MOV     AH,AL                ; SAVE PARITY STATUS
0023 75 03                JNZ    NM1_1                ;
0025 E9 00C1 R           JMP     D14                  ; NO, EXIT FROM ROUTINE
0028                                NM1_1:
;----- GET THE SWITCH SETTINGS
0028 B0 AD                MOV     AL,DIS_KBD          ; DISABLE THE KEYBOARD
002A E8 0000 E           CALL   C8042                ;
002D E4 60                IN     AL,PORT_A            ; FLUSH
002F B0 C0                MOV     AL,READ_8042_INPUT  ; GET THE SWITCH SETTINGS
0031 E8 0000 E           CALL   C8042                ; ISSUE THE COMMAND
0034 E8 0000 E           CALL   OFB_42               ; WAIT FOR OUTPUT BUFF FULL
0037 E4 60                IN     AL,PORT_A            ; GET THE SWITCH
0039 E6 80                OUT    MFG_PORT,AL         ; SAVE SWITCH
003B BA ----- R       MOV     DX,DATA              ;
003E 8E DA                MOV     DS,DX                ;
0040 BE 0000 E           MOV     SI,OFFSET D1        ; ADDR OF ERROR MSG
0043 F6 C4 40             TEST   SI,40H                ; /O PARITY CHECK
0046 75 03                JNZ    NM1_2                ; DISPLAY ERROR MSG
0048 BE 0000 E           MOV     SI,OFFSET D2        ; MUST BE PLANAR
0048                                NM1_2:
004B B4 00                MOV     AH,0                 ; INIT AND SET MODE FOR VIDEO
004D A0 0049 R           MOV     AL,CRT_MODE         ;
0050 CD 10                INT    10H                  ; CALL VIDEO IO PROCEDURE
0052 E8 0000 E           CALL   P_MSG                ; PRINT ERROR MSG
;----- SET LOCATION THAT CAUSED PARITY
0055 B0 FF                MOV     AL,OFFH             ; MASK TRAP
0057 E6 70                OUT    CMOS_PORT,AL         ;
0059 E4 61                IN     AL,PORT_B            ;
005B EB 00                JMP     SHORT $+2            ; IO DELAY
005D 0C 0C                OR     AL,RAM_PAR_OFF       ; TOGGLE PARITY CHECK ENABLES
005F E5 61                OUT    PORT_B,AL            ;
0061 EB 00                JMP     SHORT $+2            ; IO DELAY
0063 24 F3                AND    AL,RAM_PAR_ON        ;
0065 E6 61                OUT    PORT_B,AL            ;
0067 8B 1E 0013 R        MOV     BX,MEMORY_SIZE      ; GET MEMORY SIZE WORD
0068 FC                CLD                           ; SET DIR FLAG TO INCREMENT
006C 2B D2                SUB    DX,DX                 ; POINT DX AT START OF MEM
006E                                NM1_LOOP:
006E 8E DA                MOV     DS,DX                ;
0070 8E C2                MOV     ES,DX                ;
0072 B9 8000             MOV     CX,4000H*2          ; SET FOR 64KB SCAN
0075 2B F6                SUB    SI,SI                 ; SET SI TO BE RELATIVE TO
; START OF ES
0077 F3/ AD              REP    LODSW                  ; READ 64KB OF MEMORY
0079 E4 61                IN     AL,PORT_B            ; SEE IF PARITY CHECK HAPPENED
007B 86 C4                XCHG  AL,AH                 ; SAVE PARITY CHECK
007D 81 FA 4000          CMP    DX,4000H             ; CHECK FOR END OF FIRST 256K
0081 72 0C                JB     NM1_3                 ;
0083 81 FA 8000          CMP    DX,8000H             ; CHECK ABOVE 512K
0087 73 0C                JAE   NM1_4                 ; CHECK FOR IO CHECK
0089 E4 80                IN     AL,MFG_PORT          ; GET THE SWITCH SETTINGS
008B AB 10                TEST   AL,DISE_RAM         ; CHECK FOR 2ND 256K ON PLANAR
008D 74 06                JZ     NM1_4                 ; GO IF NOT
008F F6 C4 80            TEST   MFG_PORT             ; CHECK FOR PARITY ERR
0092 EB 04 90             JMP     NM1_3                 ; CONTINUE
0095 F6 C4 40            TEST   AH,TO_CHK            ; TEST FOR IO ERROR
0098 75 11                JNZ   PRT_NM1               ; GO PRINT ADDRESS IF IT DID
009A 81 C2 1000          ADD    DX,1000H             ; POINT TO NEXT 64K BLOCK
009E 83 EB 40            SUB    BX,160M*4            ;
00A1 75 CB                JNZ   NM1_LOOP              ;
00A3 BE 0000 E           MOV     SI,(OFFSET D2A)     ; PRINT ROW OF ????? IF PARITY
00A6 E8 0000 E           CALL   P_MSG                ; CHECK COULD NOT BE RE-CREATED
00A9 FA                CLI                           ;
00AA F4                HLT                          ; HALT SYSTEM
00AB                                PRT_NM1:
00AB 8C DA                MOV     DX,DS                ;
00AD E8 0000 E           CALL   PRT_SEG              ; PRINT SEGMENT VALUE
00B0 B0 28                MOV     AL,( )              ; PRINT (S)
00B2 E8 0000 E           CALL   PRT_HEX              ;
00B5 B0 53                MOV     AL,(S)              ;
00B7 E8 0000 E           CALL   PRT_HEX              ;
00BA B0 29                MOV     AL,( )              ;
00BC E8 0000 E           CALL   PRT_HEX              ;
00BF FA                CLI                           ; HALT SYSTEM
00C0 F4                HLT                          ;
00C1                                D14:
00C1 B0 8F                MOV     AL,8FH              ; TOGGLE NMI
00C3 E6 70                OUT    CMOS_PORT,AL         ;
00C5 E8 00             JMP     SHORT $+2            ; IO DELAY
00C7 B0 0F                MOV     AL,OFFH             ;
00C9 E6 70                OUT    CMOS_PORT,AL         ;
00CB 58                POP    AX                    ; RESTORE ORIG CONTENTS OF AX
00CC CF                IRET                         ;
00CD                                NM1_INT_1_ENDP
PAGE
-----
THIS ROUTINE INITIALIZES THE TIMER DATA AREA IN THE
ROM BIOS DATA AREA. IT IS CALLED BY THE POWER ON
ROUTINES. IT CONVERTS HR:MIN:SEC FROM CMOS TO TIMER
TICS. IF CMOS IS INVALID, TIMER DATA IS SET TO ZERO.
-----
INPUT      NONE PASSED TO ROUTINE BY CALLER
CMOS BYTES USED FOR SETUP
00          SECONDS
02          MINUTES
04          HOURS
0A          REGISTER A (UPDATE IN PROGRESS)
0E          CMOS VALID IF ZERO
OUTPUT     TIMER_LOW
           TIMER_HIGH
           TIMER_OFL
           ALL REGISTERS UNCHANGED
-----
= 0012          COUNTS_SEC          EQU     18
= 0044          COUNTS_MIN          EQU     1092
= 0007          COUNTS_HOUR         EQU     7
; 65543 - 65536
= 0070          CMOS_ADR           EQU     70H
= 0071          CMOS_DATA          EQU     71H
= 000E          CMOS_VALID         EQU     0EH
= 0000          CMOS_SECONDS       EQU     00H
= 0002          CMOS_MINUTES       EQU     02H
= 0004          CMOS_HOURS         EQU     04H
= 000A          CMOS_REGA          EQU     0AH
= 0080          UPDATE_TIMER       EQU     80H
00CD          SET_TOD              PROC    NEAR
           PUSH

```

```

00CD 60          +          DB      060H
00CE 1E          +          PUSH   DS
                                ASSUME DS:DATA
00CF 88 ---- R   +          MOV    AX,DATA          ; ESTABLISH SEGMENT
00D2 8E D8       +          MOV    DS,AX
00D4 2B C0       +          SUB    AX,AX
00D6 A2 0070 R   +          MOV    TIMER_OFL,AL
00D9 A3 006C R   +          MOV    TIMER_LOW,AL
00DC A3 006E R   +          MOV    TIMER_HIGH,AX
00DF 80 0E       +          MOV    AL,CMOS_VALID
00E1 E6 70       +          OUT   CMOS_ADR,AL
00E3 EB 00       +          JMP    SHORT S+2
00E5 E4 71       +          IN    AL,CMOS_DATA
00E7 24 C4       +          AND   AL,0C0H
00E9 75 61       +          JNZ   POD_DONE
00EB 2B C9       +          SUB    CX,CX
00ED 80 0A       +          MOV    AL,CMOS_REGA
00EF EB 00       +          OUT   CMOS_ADR,AL
00F1 EB 00       +          JMP    SHORT S+2
00F3 E4 71       +          IN    AL,CMOS_DATA
00F5 A8 80       +          TEST  AL,UPDATE_TIMER
00F7 74 05       +          JZ    READ_SEC
00F9 E2 F2       +          LOOP UIP
00FB EB 4F 90     +          JMP    POD_DONE          ; CMOS CLOCK STUCK
                                READ_SEC:
00FE 80 00       +          MOV    AL,CMOS_SECONDS
0100 E6 70       +          OUT   CMOS_ADR,AL
0102 EB 00       +          JMP    SHORT S+2
0104 E4 71       +          IN    AL,CMOS_DATA
                                CMP    AL,59H
0106 3C 59       +          JA    TOD_ERROR
0108 77 4D       +          ; ARE THE SECONDS WITHIN LIMITS?
                                ; GO IF NOT
                                CALL   CVT_BINARY
010A EB 0176 R   +          MOV    BL,COUNTS_SEC
010D 83 12       +          MUL  BL
010F F6 E3       +          MOV    CX,AX
0111 8B C8       +          MOV    AL,CMOS_MINUTES
0113 80 02       +          OUT   CMOS_ADR,AL
0115 E6 70       +          JMP    SHORT S+2
0117 EB 00       +          IN    AL,CMOS_DATA
0119 E4 71       +          ; ARE THE MINUTES WITHIN LIMITS?
                                ; GO IF NOT
                                CMP    AL,59H
011B 3C 59       +          JA    TOD_ERROR
011D 77 38       +          ; CONVERT IT TO BINARY
                                CALL   CVT_BINARY
011F EB 0176 R   +          MOV    BX,COUNTS_MIN
0122 8B 0444     +          MUL  BX
0125 F7 E3       +          ADD  AX,CX
0127 03 C1       +          MOV    CX,AX
0129 8B C8       +          MOV    AL,CMOS_HOURS
012B 80 04       +          OUT   CMOS_ADR,AL
012D E6 70       +          JMP    SHORT S+2
012F EB 00       +          IN    AL,CMOS_DATA
0131 E4 71       +          CMP    AL,23H
0133 3C 23       +          JA    TOD_ERROR
0135 77 20       +          CALL  CVT_BINARY
0137 EB 0176 R   +          MOV    DX,AX
013A 8B D0       +          MOV    BL,COUNTS_HOUR
013C 83 07       +          MUL  BL
013E F6 E3       +          ADD  AX,CX
0140 03 C1       +          ADC  DX,0000H
0142 83 D2 00     +          MOV    TIMER_HIGH,DX
0145 89 16 006E R +          MOV    TIMER_LOW,AX
0149 A3 006C R   +          ; ** IO DELAY NOT REQUIRED **
                                ; BE SURE TIMER IS ENABLED
                                CLI
014C FA          +          IN    AL,021H
014D E4 21       +          AND   AL,0FH
014F 24 FE       +          OUT  021H,AL
0153 FB         +          STI
0154 1F         +          POP  DS
                                POP  POPA
0155 61         +          DB    061H
0156 C3         +          RET
                                TOD_ERROR:
0157 1F         +          POP  DS
                                POPA POPA
0158 61         +          DB    061H
0159 BE 0000 E   +          SI  OFFSET CM3
015C E8 0000 E   +          CALL E_MSG
015F 80 8E       +          MOV    AL,DIAG_STATUS
0161 E6 70       +          OUT  CMOS_PORT,AL
0163 86 C4       +          XCHG AL,AH
0165 EB 00       +          JMP    SHORT S+2
0167 E4 71       +          IN    AL,CMOS_PORT+1
0169 0C 04       +          OR   AL,CMOS_CLK_FAIL
016B 86 C4       +          XCHG AL,AH
016D E6 70       +          OUT  CMOS_PORT,AL
016F 86 C4       +          XCHG AL,AH
0171 EB 00       +          JMP    SHORT S+2
0173 E6 71       +          OUT  CMOS_PORT+1,AL
0175 C3         +          RET
                                SET_TOD ENDP
0176
0176             CVT_BINARY  PROC  NEAR
0176 8A E0       +          MOV    AH,AL
                                ISHR  LABEL
0178             +          SHR   LABEL
0178 D0 EC       +          ????00 LABEL
017A             +          SHR   LABEL
0178             +          ????01 LABEL
0178             +          ORG  OFFSET CS:????00
017A             +          DB   0C0H
0178             +          ????00 LABEL
0178             +          ORG  OFFSET CS:????01
017A             +          DB   4
0178 24 0F       +          AND   AL,0FH
017D D5 0A       +          AAD
017F C3         +          RET
                                CVT_BINARY ENDP
0180             CODE  ENDS
0180             END

```

TITLE 11/22/83 BIOS1
 .LIST
 C INCLUDE SEGMENT_SRC
 C CODE SEGMENT BYTE PUBLIC
 C

0000

EXTRN DDS:NEAR
 EXTRN PRT_HEX:NEAR
 EXTRN D1:NEAR
 EXTRN D2:NEAR
 EXTRN P_MSG:NEAR
 EXTRN D2A:NEAR
 EXTRN PRT_SEG:NEAR
 EXTRN PROC_SHUTDOWN:NEAR

PUBLIC SHUT9
 PUBLIC GATE_A20
 PUBLIC CASSETTE_IO_1

```

INT 15 -----
INPUT - CASSETTE I/O FUNCTIONS
(AH) = 00
(AH) = 01
(AH) = 02
(AH) = 03
RETURNS FOR THESE FUNCTIONS ALWAYS (AH) = 86H, CF = 1
IF CASSETTE PORT NOT PRESENT
-----
INPUT - UNUSED FUNCTIONS
(AH) = 04 THROUGH 7F
RETURNS FOR THESE FUNCTIONS ALWAYS (AH) = 86H, CF = 1
-----
Extensions
(AH) = 80H  DEVICE OPEN
           (BX) = DEVICE ID
           (CX) = PROCESS ID
(AH) = 81H  DEVICE CLOSE
           (BX) = DEVICE ID
           (CX) = PROCESS ID
(AH) = 82H  PROGRAM TERMINATION
           (BX) = DEVICE ID
(AH) = 83H  EVENT WAIT
           (AL) = 0  SET INTERVAL
           (ES:BX) POINTER TO A BYTE IN CALLERS MEMORY
                   THAT WILL HAVE THE HIGH ORDER BIT SET
                   AS SOON AS POSSIBLE AFTER THE INTERVAL
                   EXPIRES.
           (CX,DX) NUMBER OF MICROSECONDS TO ELAPSE BEFORE
                   POSTING.
           (AL) = 1  CANCEL
(AH) = 84H  JOYSTICK SUPPORT
           (DX) = 0  - READ THE CURRENT SWITCH SETTINGS
                   RETURNS AL = SWITCH SETTINGS (BITS 7-4)
           (DX) = 1  - READ THE RESISTIVE INPUTS
                   RETURNS AX = A(x) VALUE
                   BX = A(y) VALUE
                   CX = B(x) VALUE
                   DX = B(y) VALUE
(AH) = 85H  SYSTEM REQUEST KEY PRESSED
           (AL) = 00 MAKE OF KEY
           (AL) = 01 BREAK OF KEY
(AH) = 86H  WAIT
           (CX,DX) NUMBER OF MICROSECONDS TO ELAPSE BEFORE
                   RETURN TO CALLER
(AH) = 87H  MOVE BLOCK
           (CX) NUMBER OF WORDS TO MOVE
           (ES:SI) POINTER TO DESCRIPTOR TABLE
(AH) = 88H  EXTENDED MEMORY SIZE DETERMINE
(AH) = 89H  PROCESSOR TO VIRTUAL MODE
(AH) = 90H  DEVICE BUSY LOOP
           (AL) SEE TYPE CODE
(AH) = 91H  INTERRUPT COMPLETE FLAG SET
           (AL) TYPE CODE
           00H -> 7FH
                   SERIALLY REUSABLE DEVICES;
                   OPERATING SYSTEM MUST SERIALIZE
                   ACCESS
           80H -> BFH
                   REENTRANT DEVICES; ES:BX IS
                   USED TO DISTINGUISH DIFFERENT
                   CALLS (MULTIPLE I/O CALLS ARE
                   ALLOWED SIMULTANEOUSLY)
           COH -> FFH
                   WAIT ONLY CALLS; THERE IS NO
                   COMPLEMENTARY 'POST' FOR THESE
                   WAITS - THESE ARE TIMEOUT
                   ONLY. TIMES ARE FUNCTION NUMBER:
                   DEPENDENT

           TYPE DESCRIPTION TIMEOUT
           00H = DISK YES
           01H = DISKETTE YES
           02H = KEYBOARD NO
           80H = NETWORK NO
                   ES:BX -> NCB
           FDH = DISKETTE MOTOR START YES
           FEH = PRINTER YES
-----

```

0000
 0000 FB 80 FC 80
 0004 72 46 80
 0006 80 EC 80
 0009 0A E4
 000B 74 45
 000D FE CC
 000F 74 41
 0011 FE CC
 0013 74 3D
 0015 FE CC
 0017 74 3B
 0019 FE CC
 001B 74 78
 001D FE CC
 001F 74 31
 0021 FE CC
 0023 74 07
 0025 FE CC

```

ASSUME CS:CODE
CASSETTE_IO_1 PROC FAR
    STI
    CMP AH,80H ; CHECK FOR RANGE
    JB C1 ; RETURN IF 00-7FH
    SUB AH,80H ; BASE 0 0
    OR AH,AH
    JZ DEV_OPEN ; DEVICE OPEN
    DEC AH
    JZ DEV_CLOSE ; DEVICE CLOSE
    DEC AH
    JZ PROC_TERM ; PROGRAM TERMINATION
    DEC AH
    JZ EVENT_WAIT ; EVENT WAIT
    DEC AH
    JZ JOY_STICK ; JOYSTICK BIOS
    DEC AH
    JZ SYS_REQ ; SYSTEM REQUEST KEY
    DEC AH
    JZ C1_A ; WAIT
    DEC AH

```

```

0027 75 06          JNZ  C1_B          ;
0029 E9 0183 R     JMP  BLOCKMOVE      ; MOVE BLOCK

002C E9 0132 R     C1_A: JMP  WAIT          ; WAIT

002F FE CC          C1_B: DEC  AH          ;

0031 75 03          JNZ  C1_C          ;
0033 E9 03D2 R     JMP  EXT_MEMORY     ; GO GET THE EXTENDED MEMORY

0036 FE CC          C1_C: DEC  AH          ;
0038 75 03          JNZ  C1_D          ; CHECK FOR FUNTION 89
003A E9 03E6 R     JMP  SET_VMODE     ; SWAP TO VIRTUAL MODE

003D 80 EC 07       C1_D: SUB  AH,7        ; CHECK FOR FUNCTION 90
0040 75 03          JNZ  C1_E          ; GO IF NOT
0042 E9 0475 R     JMP  DEVICE_BUSY   ;

0045 FE CC          C1_E: DEC  AH          ; CHECK FOR FUNCTION 8B
0047 75 03          JNZ  C1            ; GO IF NOT
0049 E9 0479 R     JMP  INT_COMPLETE  ;

004C B4 86          C1:   STC  AH,86H    ; SET BAD COMMAND
004E F9            STC                   ; SET CARRY FLAG ON
004F CA 0002       C1_F: RET  2          ;

0052              DEV_OPEN:
0052              DEV_CLOSE:
0052              PROG_TERM:

0052              SYS_REQ:
0052 EB FB          JMP  C1_F          ; RETURN
0054              CASSETTE_IO_1
0054              ENDP

0054              EVENT_WAIT  PROC NEAR
0054 1E            ASSUME CS:CODE,DS:DATA
0055 E8 0000 E     PUSH DS              ; SAVE
0056 F6 06 00A0 R 01 CALL DDS            ;
005D 74 04        TEST RTG_WAIT_FLAG,01 ; CHECK FOR FUNCTION ACTIVE
005F 1F          JZ  EVENT_WAIT_1    ;
0060 F9          POP  DS              ;
0061 EB EC          JMP  C1_F          ; SET ERROR
0063              ; RETURN

0063 FA          EVENT_WAIT_1:
0064 E4 A1        CLT                    ; NO INTERRUPTS ALLOWED
0066 24 FE        IN  AL,0A1H          ; ENSURE INTERRUPT UNMASKED
0068 E6 A1        AND  AL,0FEH          ;
006A 8C 06 009A R 01 MOV  USER_FLAG_SEG,ES ; SET UP TRANSFER TABLE
006E 89 1E 0098 R 01 MOV  USER_FLAG,BX   ;
0072 89 0E 009E R 01 MOV  RTC_HIGH,CX    ;
0076 89 16 009C R 01 MOV  RTC_LOW,DX     ;
007A C6 06 00A0 R 01 MOV  RTC_WAIT_FLAG,01 ; SET ON FUNCTION ACTIVE SWITCH
007F 80 0B        MOV  AL,0BH          ; ENABLE PIE
0081 E6 70        OUT  CMOS_PORT,AL   ;
0083 E4 71        IN  AL,CMOS_PORT+1 ;
0085 24 7F        AND  AL,07FH          ;
0087 0C 40        OR  AL,040H          ;
0089 50          PUSH AX              ;
008A 80 0B        MOV  AL,0BH          ;
008C E6 70        OUT  CMOS_PORT,AL   ;
008E 58          POP  AX              ;
008F E6 71        OUT  CMOS_PORT+1,AL  ;
0091 FB          STI                    ; ENABLE INTERRUPTS
0092 1F          POP  DS              ;
0093 EB BA          JMP  C1_F          ;
0095              ENDP

EVENT_WAIT
----- JOY_STICK
THIS ROUTINE WILL READ THE JOYSTICK PORT
-----
INPUT
(DX)=0 READ THE CURRENT SWITCHES
RETURNS (AL)= SWITCH SETTINGS IN BITS 7-4

(DX)=1 READ THE RESISTIVE INPUTS
RETURNS (AX)=A(x) VALUE
(BX)=A(y) VALUE
(CX)=B(x) VALUE
(DX)=B(y) VALUE

CY FLAG ON IF NO ADAPTER CARD OR INVALID CALL
-----

0095              ASSUME CS:CODE
0095 FB          JOY_STICK: PROC NEAR
0096 8B C2        STI                    ; INTERRUPTS BACK ON
0098 8A 0201     MOV  AX,DX          ; GET SUBFUNCTION CODE
009B 0A C0        OR  AL,AL          ; ADDRESS OF PORT
009D 74 09        JZ  JOY_2          ; READ SWITCHES
009F FE C8        DEC  AL            ;
00A1 74 0A        JZ  JOY_3          ; READ RESISTIVE INPUTS
00A3 EB A7        JMP  C1            ; GO TO ERROR RETURN

00A5              JOY_1:
00A5 FB          STI                    ;
00A6 EB A7        JMP  C1_F          ; GO TO COMMON RETURN

00A8              JOY_2:
00A8 EC          IN  AL,DX          ;
00A9 24 F0        AND  AL,0F0H       ; STRIP UNWANTED BITS OFF
00AB EB F8        JMP  JOY_1         ; FINISHED

00AD              JOY_3:
00AD B3 01        MOV  BL,1          ;
00AF E8 00CB R 01 CALL TEST_CORD     ;
00B2 51          PUSH CX            ; SAVE A(x) VALUE
00B3 83 02        MOV  BL,2          ;
00B5 E8 00CB R 01 CALL TEST_CORD     ;
00B8 51          PUSH CX            ; SAVE A(y) VALUE
00B9 B3 04        MOV  BL,4          ;
00BB E8 00CB R 01 CALL TEST_CORD     ;
00BE 51          PUSH CX            ; SAVE B(x) VALUE
00BF B3 08        MOV  BL,8          ;
00C1 E8 00CB R 01 CALL TEST_CORD     ;
00C4 8B D1        MOV  DX,CX         ; SAVE B(y) VALUE
00C6 59          POP  CX            ; GET B(x) VALUE
00C7 5B          POP  BX            ; GET A(y) VALUE
00C8 58          POP  AX            ; GET A(x) VALUE
00C9 EB DA        JMP  JOY_1         ; FINISHED - RETURN

00CB              TEST_CORD  PROC NEAR
00CB 52          PUSH DX              ; SAVE

```

```

00CC FA          CLI          ; BLOCK INTERRUPTS WHILE READING
00CD 80 00      MOV          AL,0          ; SET UP TO LATCH TIMER 0
00CF E6 43      OUT          TIMER+3,AL ;
00D1 E8 00      JMP          SHORT $+2      ;
00D3 E4 40      IN           AL,TIMER    ; READ LOW BYTE OF TIMER 0
00D5 FB 00      JMP          SHORT $+2      ;
00D7 8A E0      MOV          AH,AL         ;
00D9 E4 40      IN           AL,TIMER    ; READ HIGH BYTE OF TIMER 0
00DB 86 E0      XCHG         AH,AL         ; REARRANGE TO HIGH,LOW
00DD 90         PUSH         AX           ; SAVE
00DE 89 04FF    MOV          CX,4FFH       ; SET COUNT
00E1 EE         OUT          DX,AL         ; FIRE TIMER
00E2 EB 00      JMP          SHORT $+2      ;
                                TEST_CORD_1:
00E4           IN           AL,DX          ; READ VALUES
00E5 84 C3      TEST          AL,BL         ; HAS PULSE ENDED?
00E7 E0 FB      LOOPNZ        TEST_CORD_1  ;
00E9 83 F9 00   CMP          CX,0          ;
00EB 59         POP          CX           ; ORIGINAL COUNT
00ED 75 04      JNZ          SHORT TEST_CORD_2 ;
00EF 2B C9      SUB          CX,CX         ; SET ; COUNT FOR RETURN
00F1 EB 2D      JMP          SHORT TEST_CORD_3 ; ; EXIT WITH COUNT = 0
                                TEST_CORD_2:
00F3 80 00      MOV          AL,0          ; SET UP TO LATCH TIMER 0
00F5 E6 43      OUT          TIMER+3,AL ;
00F7 EB 00      JMP          SHORT $+2      ;
00F9 E4 40      IN           AL,TIMER    ; READ LOW BYTE OF TIMER 0
00FB 8A E0      MOV          AH,AL         ;
00FD EB 00      JMP          SHORT $+2      ;
00FF E4 40      IN           AL,TIMER    ; READ HIGH BYTE OF TIMER 0
0101 86 E0      XCHG         AH,AL         ; REARRANGE TO HIGH,LOW
                                TEST_CORD_3:
0103 3B C8      CMP          CX,AX         ; CHECK FOR COUNTER WRAP
0105 73 0B      JAE          TEST_CORD_4   ; GO IF NO
0107 52         PUSH         DX           ;
0108 BA FFFF    MOV          DX,-1         ;
                                TEST_CORD_4:
010B 2B D0      SUB          DX,AX         ; ADJUST FOR WRAP
010D 03 CA      ADD          CX,DX         ;
010F 5A         POP          DX           ;
0110 EB 02      JMP          SHORT TEST_CORD_5 ;
                                TEST_CORD_4:
0112           SUB          CX,AX         ;
                                TEST_CORD_5:
0114           AND          CX,1FF0H      ; ADJUST
0116 01 E9      SHR          CX,1          ;
0118 01 E9      SHR          CX,1          ;
011A 01 E9      SHR          CX,1          ;
011C 01 E9      SHR          CX,1          ;
011E 01 E9      SHR          CX,1          ;
                                TEST_CORD_3:
0120           STI          ; INTERRUPTS BACK ON
0121 8A 0201    MOV          DX,201H       ; FLUSH OTHER INPUTS
0124 51         PUSH         CX           ;
0125 50         PUSH         AX           ;
0126 89 04FF    MOV          CX,4FFH       ; COUNT
                                TEST_CORD_6:
0129           IN           AL,DX          ;
012A A8 0F      TEST         AL,0FH        ;
012C E0 FB      LOOPNZ        TEST_CORD_6  ;
                                TEST_CORD_6:
012E 5B         POP          AX           ;
012F 59         POP          CX           ;
0130 5A         POP          DX           ; SET COUNT
                                TEST_CORD_6:
0131 C3          RET          ; RETURN
                                TEST_CORD_6:
0132           ENDP          TEST_CORD_6
                                JOY_STICK:
0132           ENDP          JOY_STICK
                                WAIT:
0132 PROC        NEAR
0133 PUSH         DS          ; SAVE
0133 CALL        DDS         ;
0136 F6 06 00A0 R 01 TEST         RTC_WAIT_FLAG,01 ; TEST FOR FUNCTION ACTIVE
0138 74 05      JZ          WAIT_1        ;
0139 1F         POP          DS          ;
013E F9         STC          ; SET ERROR
013F E9 004F R  JMP          C1_F         ; RETURN
                                WAIT_1:
0142 FA         CLI          ; NO INTERRUPTS ALLOWED
0143 E4 A1      IN           AL,0A1H       ; ENSURE INTERRUPT UNMASKED
0145 24 FE      AND          AL,0FEH       ;
0147 E6 A1      OUT          0A1H,AL       ;
0149 8C 1E 009A R  MOV          USER_FLAG_SEG,DS ; SET UP TRANSFER TABLE
014D C7 06 0098 R 00A0 R  MOV          USER_FLAG_OFFSET,RTC_WAIT_FLAG ;
0153 89 0E 009E R  MOV          RTC_HIGH,CX    ;
0157 89 16 009C R  MOV          RTC_LOW,DX     ;
015B C6 06 00A0 R 01 MOV          RTC_WAIT_FLAG,01 ; SET ON FUNCTION ACTIVE SWITCH
0160 80 0B      MOV          AL,0BH        ; ENABLE PIE
0162 E6 70      MOV          AL,CMOS_PORT,AL ;
0164 E4 71      IN           AL,CMOS_PORT+1 ;
0166 24 7F      AND          AL,07FH       ;
0168 0C 40      OR           AL,040H       ;
016A 50         PUSH         AX           ;
016B 80 0B      MOV          AL,0BH        ;
016D E6 70      MOV          CMOS_PORT,AL  ;
016F 58         POP          AX           ;
0170 E6 71      MOV          CMOS_PORT+1,AL ;
0172 FB         STI          ; ENABLE INTERRUPTS
                                WAIT_2:
0173 F6 06 00A0 R 80 TEST         RTC_WAIT_FLAG,080H ; CHECK FOR END OF WAIT
0178 74 F9      JZ          WAIT_2        ;
017A C6 06 00A0 R 00 MOV          RTC_WAIT_FLAG,0 ; SET FUNCTION INACTIVE
017F 1F         POP          DS          ;
0180 E9 004F R  JMP          C1_F         ;
                                WAIT:
0183           ENDP          WAIT
                                PAGE:
0183           ENDP          PAGE

```

```

;----- INT 15 (FUNCTION 87H - MOVE BLOCK) -----
; PURPOSE:
; THIS BIOS FUNCTION PROVIDES A MEANS TO TRANSFER A BLOCK
; OF STORAGE TO AND FROM STORAGE ABOVE THE 1 MEG ADDRESS
; RANGE IN VIRTUAL (PROTECTED) MODE.
;
; ENTRY REQUIREMENTS:
;
; ES:SI POINTS TO A DESCRIPTOR TABLE (GDT) BUILT BEFORE
; INTERRUPTING TO THIS FUNCTION. THESE DESCRIPTORS ARE
; USED BY THIS FUNCTION TO PERFORM THE BLOCK MOVE.
; THE SOURCE AND TARGET DESCRIPTORS BUILT BY THE USER
; MUST HAVE THE SEGMENT LENGTH = 2 * CX - 1 OR GREATER.
; THE DATA ACCESS RIGHTS BYTE WILL BE SET TO CPLO-R/(93H);
; THE 24 BIT ADDRESS (BYTE HI, WORD LOW) WILL BE SET
; TO THE TARGET/SOURCE.
;
; THE DESCRIPTORS ARE DEFINED AS FOLLOWS:

```

1. THE FIRST DESCRIPTOR IS THE REQUIRED DUMMY.
(USER INITIALIZED TO 0)
2. THE SECOND DESCRIPTOR POINTS TO THE GDT TABLE AS
A DATA SEGMENT.
(USER INITIALIZED TO 0)
3. THE THIRD DESCRIPTOR IS THE DESCRIPTOR THAT POINTS
TO THE SOURCE TO BE MOVED. (FROM)
(USER INITIALIZED)
4. THE FOURTH DESCRIPTOR IS THE DESCRIPTOR THAT POINTS
TO THE DESTINATION. (TO)
(USER INITIALIZED)
5. THE FIFTH IS A DESCRIPTOR THAT THIS FUNCTION USES
TO CREATE A VIRTUAL CODE SEGMENT
(USER INITIALIZED TO 0)
6. THE SIXTH IS A DESCRIPTOR THAT THIS FUNCTION USES
TO CREATE A VIRTUAL STACK SEGMENT. (POINTS TO USERS
STACK)
(USER INITIALIZED TO 0)

PAGE

INT 15 (FUNCTION 87H CONTINUED)

AH=87 (FUNCTION CALL)
ES:SI = LOCATION OF THE GDT TABLE BUILT BY ROUTINE
USING THIS FUNCTION.
CX = WORD COUNT OF STORAGE BLOCK TO BE MOVE.

NOTE: MAX COUNT = 8000H 32K WORDS

EXIT PARAMETERS:

AH = 0 IF SUCCESSFUL
AH = 1 IF RAM PARITY (PARITY ERROR IS CLEARED)
AH = 2 IF EXCEPTION INTERRUPT ERROR
AH = 3 IF GATE ADDRESS LINE 20 FAILED
ALL REGISTER ARE RESTORED EXCEPT AX.
CARRY FLAG = 1 IF ERROR
ZERO FLAG = 1 IF SUCCESSFUL

CONSIDERATIONS:

NO INTERRUPTS ARE ALLOWED.
TIME OF DAY (ADJUSTED BY USER???)

DESCRIPTION:

1. CLI (NO INTERRUPTS ALLOWED) WHILE THIS FUNCTION IS
EXECUTING.
2. ADDRESS LINE 20 IS GATED ACTIVE.
3. THE IDT (INTERRUPT DESCRIPTOR TABLE) IS ROM RESIDENT.
4. THE CURRENT USER STACK SEGMENT AND OFFSET IS SAVED.
5. THE GDTR IS LOADED WITH THE OFFSET INTO ES:SI
6. THE IDTR SELECTOR IS ROM RESIDENT AND IS LOADED.
7. THE PROCESSOR IS PUT IN VIRTUAL MODE
8. DATA SEGMENT IS LOADED WITH THE SOURCE DESCRIPTOR
9. EXTRA SEGMENT IS LOADED WITH THE TARGET DESCRIPTOR
10. DS:SI (SOURCE) ES:DI (TARGET) REP MOVSB IS EXECUTED
11. SHUTDOWN 09 IS EXECUTED.
12. STACK SEGMENT/OFFSET IS RESTORED.
13. ADDRESS LINE 20 IS DEGATED.
14. INTERRUPTS ARE ALLOWED

page

THE FOLLOWING DIAGRAM DEPICTS THE ORGANIZATION
OF GDT.

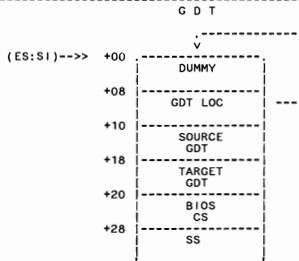

SAMPLE OF SOURCE OR TARGET DESCRIPTOR

```

SOURCE_TARGET_DEF      STRUC
SEG_LIMIT               DW      ; SEGMENT LIMIT (1-65536 BYTES)
BASE_LO_WORD           DW      ; 24 BIT SEGMENT PHYSICAL
BASE_HI_BYTE           DB      ; ADDRESS (0 TO (16M-1))
DATA_ACC_RIGHTS       DB      ; ACCESS RIGHTS BYTE
DATA_RESERVED         DW      ; RESERVED WORD
SOURCE_TARGET          ENDS
  
```

THE GLOBAL DESCRIPTOR TABLE (ACTUAL LOCATION POINTED TO BY ES:SI)

BLOCKMOVE_GDT_DEF

STRUC

```

0000 00 00 00 00 00 00    DUMMY  DQ  0      ; FIRST DESCRIPTOR NOT ACCESSIBLE
0000 00 00 00 00 00 00    CGDT_LOC DQ  0    ; LOCATION OF CALLING ROUTINE GDT
0008 00 00 00 00 00 00    SOURCE  DQ  0    ; SOURCE DESCRIPTOR
0010 00 00 00 00 00 00    TARGET  DQ  0    ; TARGET DESCRIPTOR
0018 00 00 00 00 00 00    BIOS_CS DQ  0    ; BIOS CODE DESCRIPTOR
0020 00 00 00 00 00 00    TEMP_SS DQ  0    ; STACK DESCRIPTOR
0028 00 00 00 00 00 00
0030 00 00 00 00 00 00
BLOCKMOVE_GDT_DEF      ENDS
  
```

```

                                ASSUME CS:CODE
                                ASSUME DS:DATA

0183                                BLOCKMOVE PROC NEAR

;----- INITIALIZE FOR VIRTUAL MODE

0183 FA                                CLI                                ; NO INTERRUPTS ALLOWED
0184 FC                                CLD                                ; SET DIRECTION
                                PUSHA                                ; SAVE GENERAL PURPOSE REGS
0185 60                                + DB 060H                            ;
0186 06                                PUSH ES                            ; SAVE EXTRA SEGMENT
0187 1E                                PUSH DS                            ;

;----- CLEAR EXCEPTION ERROR FLAG

0188 2A C0                                SUB AL,AL                            ;
018A E6 80                                OUT MFG_PORT,AL                    ; SET TO 0

;----- GATE ADDRESS BIT 20 ON

018C B4 DF                                MOV AH,ENABLE_BIT20                ;
018E E8 03B0 R                          CALL GATE_A20                        ;
0191 3C 00                                CMP AL,0                            ; WAS THE COMMAND ACCEPTED?
0193 74 07                                JZ BL4                              ; GO IF YES
0195 B0 03                                MOV AL,03H                          ; SET THE ERROR FLAG
0197 E6 80                                OUT MFG_PORT,AL                    ;
0199 E9 0270 R                          JMP SHUT5                            ; EARLY EXIT

;----- SET SHUTDOWN RETURN ADDR

019C B0 8F                                BL4: MOV AL,SHUT_DOWN                ; SET THE SHUTDOWN BYTE
019E E6 70                                OUT CMOS_PORT,AL                    ; TO SHUT DOWN 9
01A0 EB 00                                JMP SHORT $+2                        ; 10 DELAY
01A2 B0 09                                MOV AL,9                            ;
01A4 E6 71                                OUT CMOS_PORT+1,AL                  ;

;=====
;----- SET UP THE GDT DEFINITION
;=====
;----- MAKE A 24 BIT ADDRESS OUT OF THE ES:SI

01A6 8C C0                                MOV AX,ES                            ; GET THE CURRENT DATA SEGMENT
01A8 8B DE                                MOV BX,SI                            ; GET THE CURRENT OFFSET
01AA 8A F4                                MOV DH,AH                            ; DEVELOPE THE HIGH BYTE OF THE 24BIT ADDR
01AC 80 E6 F0                            AND DH,0FOH                          ; USE ONLY THE HIGH NIBBLE
                                ISHR DH,4                            ; SHIFT RIGHT 4
01AF 01AF 00 EE                            + ????000 LABEL BYTE
                                SHR DH,1                              ;
01B1 01AF 00 EE                            + ????001 LABEL BYTE
                                ORG OFFSET CS:????000
                                DB 000H
                                + ORG OFFSET CS:????001
                                DB 4
                                + AND AH,00FH                            ; STRIP HIGH NIBBLE FROM AH
                                ISHL AX,4                            ; SHIFT AX
01B5 01B5 D1 ED                            + ????003 LABEL BYTE
                                + SHL AX,1
                                + ????004 LABEL BYTE
                                ORG OFFSET CS:????003
01B9 01B5 C1                            + ????005 LABEL NEAR
                                + DB 001H
                                + ORG OFFSET CS:????004
                                DB 4
                                + ADD BX,AX                            ; DEVELOPE THE LOW WORD ADDRESS
                                JNC BL3A                            ; GO IF NO CARRY
                                INC DH                            ; INCREMENT THE HIGH BYTE ADDRESS
                                ;=====
;----- SET THE GDT_LOC
                                BL3A: MOV ES:[SI],CGDT_LOC.BASE_HI_BYTE,DH ; SET THE HIGH BYTE
                                MOV ES:[SI],CGDT_LOC.BASE_LO_WORD,BX ; SET THE LOW WORD
01BE 26: 88 74 OC                            MOV ES:[SI],CGDT_LOC.SEG_LIMT,MAX_SEG_LEN
01C2 26: 89 5C OA                            MOV ES:[SI],CGDT_LOC.DATA_RESERVED,0 ; RESERVED

;=====
;----- LOAD THE IDT

01D2 B0 02A1 R                          MOV BP,OFFSET ROM_IDT_LOC
                                SEGOV CS                                ; LOAD THE IDT
01D5 2E                                DB 02EH
                                LIDT [BP]                            ; REGISTER FROM THIS AREA
01D6 0F                                + DB 00FH
01D7 01D7 8B 5E 00                            + ????007 LABEL BYTE
                                MOV BX,WORD PTR [BP]
01DA 01D7 01                                + ????008 LABEL BYTE
                                ORG OFFSET CS:????007
                                DB 001H
                                + ORG OFFSET CS:????008
                                DB 4

;----- LOAD THE GDTR

                                SEGOV ES                                ; LOAD THE GLOBAL DESCRIPTOR TABLE REG
01DA 26                                + DB 026H
                                LGDT [SI],CGDT_LOC
                                DB 00FH
                                + ????00A LABEL BYTE
                                MOV DX,WORD PTR [SI],CGDT_LOC
                                + ????00B LABEL BYTE
                                ORG OFFSET CS:????00A
                                DB 001H
                                + ORG OFFSET CS:????00B
                                DB 4

;----- SET THE DATA SEGMENT TO BIOS RAM

01DF E8 0000 E                          CALL DDS                            ; SET DS TO DATA AREA

;----- SAVE THE CALLING ROUTINE'S STACK

01E2 8C D0                                MOV AX,SS                            ; GET THE STACK SEGMENT
01E4 A3 0069 R                          MOV IO_ROM_SEG,AX                    ; SAVE STACK SEGMENT
01E7 8B C4                                MOV AX,SP                            ; SAVE STACK POINTER
01E9 A3 0067 R                          MOV IO_ROM_INIT,AX                    ;

PAGE
;----- MAKE A 24 BIT ADDRESS OUT OF THE SS (SP REMAINS USER SP)

01EC 8C D0                                MOV AX,SS                            ; GET THE CURRENT STACK SEGMENT
01EE 8A F4                                MOV DH,AH                            ; DEVELOPE THE HIGH BYTE OF THE 24BIT ADDR
01F0 80 E6 F0                            AND DH,0FOH                          ; USE ONLY THE HIGH NIBBLE
                                ISHR DH,4                            ; SHIFT RIGHT 4
01F3 01F3 D0 EE                            + ????00C LABEL BYTE
                                + SHR DH,1
                                + ????00D LABEL BYTE
                                + ORG OFFSET CS:????00C
                                DB 000H
                                + ORG OFFSET CS:????00D
                                DB 000H

```

```

01F5 04 + ORG OFFSET CS:??0000
01F5 04 AND DB 4
01F6 80 E4 OF + SHL AH,00FH ; STRIP HIGH NIBBLE FROM AH
; SHIFT AX
01F9 + ????0F LABEL BYTE
01F9 D1 E0 + SHL AX,1
01FB + ????010 LABEL BYTE
01F9 + ORG OFFSET CS:??000F
01F9 + ????011 LABEL NEAR
01F9 C1 + DB 0C1H
01FB 04 + ORG OFFSET CS:??0010
; DB 4
;----- SS IS NOW IN POSITION FOR A 24 BIT ADDRESS --> SETUP THE DESCRIPTOR
01FC 26: 88 74 2C BL3: MOV ES:[SI],TEMP_SS.BASE_HI_BYTE,DH ; SET THE HIGH BYTE
0200 26: 89 44 2A MOV ES:[SI],TEMP_SS.BASE_LO_WORD,AX ; SET THE LOW WORD
0204 26: C7 44 28 FFFF MOV ES:[SI],TEMP_SS.SEG_LIMIT,MAX_SEG_LEN ; SET THE SS SEGMENT LIMIT
020A 26: C6 44 2D 93 MOV ES:[SI],TEMP_SS.DATA_ACC_RIGHTS,CPLD_CODE_ACCESS ; SET CPL 0
;----- STACK IS NOW SET ----> SET UP THE CODE SEGMENT DESCRIPTOR
020F 26: C6 44 24 0F MOV ES:[SI].BIOS_CS.BASE_HI_BYTE,CSEG0_HI ; HIGH BYTE OF CS=0F
0214 26: C7 44 22 0000 MOV ES:[SI].BIOS_CS.BASE_LO_WORD,CSEG0_LO ; LOW WORD OF CS=0
021A 26: C7 44 20 FFFF MOV ES:[SI].BIOS_CS.SEG_LIMIT,MAX_SEG_LEN
0220 26: C6 44 25 98 MOV ES:[SI].BIOS_CS.DATA_ACC_RIGHTS,CPLD_CODE_ACCESS
0225 26: C7 44 26 0000 MOV ES:[SI].BIOS_CS.DATA_RESERVED,0 ; RESERVED
;----- SWITCH TO VIRTUAL MODE
022B B8 0001 MOV AX,VIRTUAL_ENABLE ; MACHINE STATUS WORD NEEDED TO
; LMSW AX ; SWITCH TO VIRTUAL MODE
022E 0F + DB 00FH
022F LABEL BYTE
022F 8B F0 + ????012 MOV SI,AX
0231 + ????013 LABEL BYTE
022F + ORG OFFSET CS:??0012
022F 01 + DB 001H
0231 + ORG OFFSET CS:??0013
JUMPFAR VIRT,BIOS_CS ; MUST PURGE PRE-FETCH QUEUE
0231 EA + DB 0EAH ; Jump far direct
0232 0236 R + DW (OFFSET VIRT) ; so this offset
0234 0020 + DW BIOS_CS ; in this segment
0236 VIRT:
;----- SET STACK SEGMENT (NEEDED FOR POSSIBLE EXCEPTIONS)
0236 B8 0028 MOV AX,TEMP_SS ; USER'S SS+SP IS NOT A DESCRIPTOR
0239 8E 00 MOV SS,AX
;----- SETUP SOURCE/TARGET REGISTERS
023B B8 0010 MOV AX,SOURCE ; GET THE SOURCE ENTRY
023E 8E 08 MOV DS,AX ;
0240 B8 0018 MOV AX,TARGET ; GET THE TARGET ENTRY
0243 8E C0 MOV ES,AX ;
0245 2B FF SUB DI,DI ; SET INDEX REGS TO ZERO
0247 2B F6 SUB SI,SI ;
0249 F3/ A5 REP MOVSW ; MOVE THE BLOCK
;----- CHECK FOR RAM PARITY BEFORE SHUTDOWN
024B E4 61 IN AL,PORT_B ; GET THE PARITY LATCHES
024D 24 C0 AND AL,PARITY_ERR ; CHECK UNWANTED BITS
024F 74 1C JZ DONE1 ; GO IF NO PARITY ERROR
;----- CLEAR PARITY BEFORE SHUTDOWN
0251 26: 88 04 MOV AX,ES:[SI] ; FETCH CURRENT TARGET DATA
0254 26: 89 04 MOV ES:[SI],AX ; WRITE IT BACK
0257 8B 05 MOV AX,DS:[DI] ; FETCH CURRENT SOURCE DATA
0259 89 05 MOV DS:[DI],AX ; WRITE IT BACK
025B B0 01 MOV AL,D1 ; SET PARITY CHECK ERROR
025D E6 80 OUT MFG_PORT,AL ;
025F E4 61 IN AL,PORT_B ;
0261 EB 00 JMP SHORT $+2 ; 10 DELAY
0263 0C 0C OR AL,RAM_PAR_OFF ; TOGGLE PARITY CHECK LATCHES
0265 E6 61 OUT PORT_B,AL ;
0267 EB 00 JMP SHORT $+2 ; 10 DELAY
0269 24 F3 AND AL,RAM_PAR_ON ;
026B E6 61 OUT PORT_B,AL ;
;----- CAUSE A SHUTDOWN
026D E9 0000 E DONE1: JMP PROC_SHUTDOWN ;
;=====
;----- RETURN FROM SHUTDOWN
;=====
0270 SHUT9: ENABLE NMI INTERRUPTS
;-----
0270 2A C0 SUB AL,AL ;
0272 E6 70 OUT CMOS_PORT,AL ;
;----- GATE ADDRESS BIT 20 OFF
0274 B4 0D MOV AH,DISABLE_BIT20 ;
0276 E8 0380 R CALL GATE_A20 ;
0279 3C 00 CMP AL,0 ; COMMAND ACCEPTED?
027B 74 0A JB DONE3 ; GO IF YES
027D E4 80 IN AL,MFG_PORT ; CHECK FOR ERROR
027F 3C 00 CMP AL,0 ; WAS THERE AN ERROR?
0281 75 04 JNZ DONE3 ; GO IF YES
0283 B0 03 MOV AL,D3H ; SET ERROR FLAG
0285 E6 80 OUT MFG_PORT,AL ;
;----- RESTORE USERS STACK
0287 E8 0000 E DONE3: CALL DDS ; SET DS TO DATA AREA
028A A1 0069 R MOV AX,IO_ROM_SEG ; SAVE STACK SEGMENT
028D 8E D0 MOV SS,AX ; RESTORE THE STACK POINTER
028F A1 0067 R MOV AX,IO_ROM_INIT ;
0292 8B E0 MOV SP,AX ;
;----- RESTORE THE USER DATA SEGMENT
0294 1F POP DS ; RESTORE USER DATA SEGMENT

```

```

0295 07          POP     ES          ; RESTORE USER EXTRA SEGMENT
0296 61          +      POPA    061H   ; RESTORE THE GENERAL PURPOSE REGS
0297 86 C4       +      XCHG   AL,AH   ; SAVE AL

0299 E4 80       IN      AL,MFG_PORT ; CHECK THE ENDING STATUS
029B 3C 00       CMP     AL,0     ; SET THE ZERO FLAG
029D 86 CD       XCHG   AH,AL     ; RESTORE AL
029F FB         STI     ; TURN INTERRUPTS ON
02A0 CF         IRET    ; RETURN TO USER

;----- ROM IDT LOCATION
= 0100          ROM_IDT_LEN EQU 32*8 ; SIZE OF THE EXCEPTION INTERRUPTS

02A1          ROM_IDT_LOC:

02A1 0100       +      DW     IDT_GDT_DEF ROM_IDT_LEN,ROM_IDT,CSEG00_HI ; Segment limit
02A3 02A7 R     +      DW     ROM_IDT_LEN ; Segment base address - low word
02A5 0F         +      DB     CSEG00_HI ; Segment base address - high byte
02A6 00         +      DB     0 ; Reserved

;----- THE ROM EXCEPTION INTERRUPT VECTORS

02A7          ROM_IDT:
;EXCEPTION 00
02A7 03A7 R     +      DW     DESCR_DEF_GATE,EX_INT,BIOS_CS,0,TRAP_GATE ; Destination offset
02A9 0020       +      DW     BI0S_CS ; Destination segment selector
02AB 00         +      DB     0 ; Word count for stack-to-stack copy (only for call gates when PL cha
nges)
02AC 87         +      DB     TRAP_GATE ; Access rights byte
02AD 0000       +      DW     0 ; Reserved
;EXCEPTION 01
02AF 03A7 R     +      DW     DESCR_DEF_GATE,EX_INT,BIOS_CS,0,TRAP_GATE ; Destination offset
02B1 0020       +      DW     BI0S_CS ; Destination segment selector
02B3 00         +      DB     0 ; Word count for stack-to-stack copy (only for call gates when PL cha
nges)
02B4 87         +      DB     TRAP_GATE ; Access rights byte
02B5 0000       +      DW     0 ; Reserved
;EXCEPTION 02
02B7 03A7 R     +      DW     DESCR_DEF_GATE,EX_INT,BIOS_CS,0,TRAP_GATE ; Destination offset
02B9 0020       +      DW     BI0S_CS ; Destination segment selector
02BB 00         +      DB     0 ; Word count for stack-to-stack copy (only for call gates when PL cha
nges)
02BC 87         +      DB     TRAP_GATE ; Access rights byte
02BD 0000       +      DW     0 ; Reserved
;EXCEPTION 03
02BF 03A7 R     +      DW     DESCR_DEF_GATE,EX_INT,BIOS_CS,0,TRAP_GATE ; Destination offset
02C1 0020       +      DW     BI0S_CS ; Destination segment selector
02C3 00         +      DB     0 ; Word count for stack-to-stack copy (only for call gates when PL cha
nges)
02C4 87         +      DB     TRAP_GATE ; Access rights byte
02C5 0000       +      DW     0 ; Reserved
;EXCEPTION 04
02C7 03A7 R     +      DW     DESCR_DEF_GATE,EX_INT,BIOS_CS,0,TRAP_GATE ; Destination offset
02C9 0020       +      DW     BI0S_CS ; Destination segment selector
02CB 00         +      DB     0 ; Word count for stack-to-stack copy (only for call gates when PL cha
nges)
02CC 87         +      DB     TRAP_GATE ; Access rights byte
02CD 0000       +      DW     0 ; Reserved
;EXCEPTION 05
02CF 03A7 R     +      DW     DESCR_DEF_GATE,EX_INT,BIOS_CS,0,TRAP_GATE ; Destination offset
02D1 0020       +      DW     BI0S_CS ; Destination segment selector
02D3 00         +      DB     0 ; Word count for stack-to-stack copy (only for call gates when PL cha
nges)
02D4 87         +      DB     TRAP_GATE ; Access rights byte
02D5 0000       +      DW     0 ; Reserved
;EXCEPTION 06
02D7 03A7 R     +      DW     DESCR_DEF_GATE,EX_INT,BIOS_CS,0,TRAP_GATE ; Destination offset
02D9 0020       +      DW     BI0S_CS ; Destination segment selector
02DB 00         +      DB     0 ; Word count for stack-to-stack copy (only for call gates when PL cha
nges)
02DC 87         +      DB     TRAP_GATE ; Access rights byte
02DD 0000       +      DW     0 ; Reserved
;EXCEPTION 07
02DF 03A7 R     +      DW     DESCR_DEF_GATE,EX_INT,BIOS_CS,0,TRAP_GATE ; Destination offset
02E1 0020       +      DW     BI0S_CS ; Destination segment selector
02E3 00         +      DB     0 ; Word count for stack-to-stack copy (only for call gates when PL cha
nges)
02E4 87         +      DB     TRAP_GATE ; Access rights byte
02E5 0000       +      DW     0 ; Reserved
;EXCEPTION 08
02E7 03A7 R     +      DW     DESCR_DEF_GATE,EX_INT,BIOS_CS,0,TRAP_GATE ; Destination offset
02E9 0020       +      DW     BI0S_CS ; Destination segment selector
02EB 00         +      DB     0 ; Word count for stack-to-stack copy (only for call gates when PL cha
nges)
02EC 87         +      DB     TRAP_GATE ; Access rights byte
02ED 0000       +      DW     0 ; Reserved
;EXCEPTION 09
02EF 03A7 R     +      DW     DESCR_DEF_GATE,EX_INT,BIOS_CS,0,TRAP_GATE ; Destination offset
02F1 0020       +      DW     BI0S_CS ; Destination segment selector
02F3 00         +      DB     0 ; Word count for stack-to-stack copy (only for call gates when PL cha
nges)
02F4 87         +      DB     TRAP_GATE ; Access rights byte
02F5 0000       +      DW     0 ; Reserved
;EXCEPTION 10
02F7 03A7 R     +      DW     DESCR_DEF_GATE,EX_INT,BIOS_CS,0,TRAP_GATE ; Destination offset
02F9 0020       +      DW     BI0S_CS ; Destination segment selector
02FB 00         +      DB     0 ; Word count for stack-to-stack copy (only for call gates when PL cha
nges)
02FC 87         +      DB     TRAP_GATE ; Access rights byte
02FD 0000       +      DW     0 ; Reserved
;EXCEPTION 11
02FF 03A7 R     +      DW     DESCR_DEF_GATE,EX_INT,BIOS_CS,0,TRAP_GATE ; Destination offset
0301 0020       +      DW     BI0S_CS ; Destination segment selector
0303 00         +      DB     0 ; Word count for stack-to-stack copy (only for call gates when PL cha
nges)
0304 87         +      DB     TRAP_GATE ; Access rights byte
0305 0000       +      DW     0 ; Reserved
;EXCEPTION 12
0307 03A7 R     +      DW     DESCR_DEF_GATE,EX_INT,BIOS_CS,0,TRAP_GATE ; Destination offset
0309 0020       +      DW     BI0S_CS ; Destination segment selector

```



```

0387 03A7 R + DW EX_INT ; Destination offset
0389 0020 + DW BIOS_CS ; Destination segment selector
038B 00 + DB 0 ; Word count for stack-to-stack copy (only for call gates when PL cha
; nges)
038C 87 + DB TRAP_GATE ; Access rights byte
038D 0000 + DW 0 ; Reserved
;EXCEPTION 29
DESCR_DEF GATE,EX_INT,BIOS_CS,0,TRAP_GATE
038F 03A7 R + DW EX_INT ; Destination offset
0391 0020 + DW BIOS_CS ; Destination segment selector
0393 00 + DB 0 ; Word count for stack-to-stack copy (only for call gates when PL cha
; nges)
0394 87 + DB TRAP_GATE ; Access rights byte
0395 0000 + DW 0 ; Reserved
;EXCEPTION 30
DESCR_DEF GATE,EX_INT,BIOS_CS,0,TRAP_GATE
0397 03A7 R + DW EX_INT ; Destination offset
0399 0020 + DW BIOS_CS ; Destination segment selector
039B 00 + DB 0 ; Word count for stack-to-stack copy (only for call gates when PL cha
; nges)
039C 87 + DB TRAP_GATE ; Access rights byte
039D 0000 + DW 0 ; Reserved
;EXCEPTION 31
DESCR_DEF GATE,EX_INT,BIOS_CS,0,TRAP_GATE
039F 03A7 R + DW EX_INT ; Destination offset
03A1 0020 + DW BIOS_CS ; Destination segment selector
03A3 00 + DB 0 ; Word count for stack-to-stack copy (only for call gates when PL cha
; nges)
03A4 87 + DB TRAP_GATE ; Access rights byte
03A5 0000 + DW 0 ; Reserved
;----- EXCEPTION INTERRUPT HANDLER
EX_INT:
03A7 MOV AL,02H ; SET EXCEPTION INT
03A7 80 02 OUT MFG_PORT,AL ;
03A9 E6 80 JMP PROC_SHUTDOWN ; CAUSE A EARLY SHUTDOWN
03AB E9 0000 E
EX_INT1:
03AE JMP EX_INT1 ; STAY HERE TILL SHUTDOWN
03AE EB FE
03B0 BLOCHMOVE ENDP
PAGE
-----
GATE_A20
; THIS ROUTINE CONTROLS A SIGNAL WHICH GATES ADDRESS BIT 20.
; THE GATE A20 SIGNAL IS AN OUTPUT OF THE 8042 SLAVE PROCESSOR.
; ADDRESS BIT 20 SHOULD BE GATED ON BEFORE ENTERING PROTECTED MODE.
; IT SHOULD BE GATED OFF AFTER ENTERING REAL MODE FROM PROTECTED
; MODE.
; INPUT
; (AH)=DDH ADDRESS BIT 20 GATE OFF. (A20 ALWAYS ZERO)
; (AH)=DFH ADDRESS BIT 20 GATE ON. (A20 CONTROLLED BY 80286)
; OUTPUT
; (AL)=0 OPERATION SUCCESSFUL. 8042 HAS ACCEPTED COMMAND.
; (AL)=2 FAILURE--8042 UNABLE TO ACCEPT COMMAND.
-----
GATE_A20 PROC
03B0 CLI ;DISABLE INTERRUPTS WHILE USING 8042
03B0 FA CALL EMPTY_8042 ; INSURE 8042 INPUT BUFFER EMPTY
03B1 EB 03C7 R JNZ GATE_A20_RETURN ;RETURN IF 8042 UNABLE TO ACCEPT COMMAND
03B4 75 10 MOV AL,0D1H ;8042 COMMAND TO WRITE OUTPUT PORT
03B6 80 D1 OUT STATUS_PORT,AL ;OUTPUT COMMAND TO 8042
03B8 E6 64 CALL EMPTY_8042 ;WAIT FOR 8042 TO ACCEPT COMMAND
03BA EB 03C7 R JNZ GATE_A20_RETURN ;RETURN IF 8042 UNABLE TO ACCEPT COMMAND
03BD 75 07 MOV AL,AH ;8042 PORT DATA
03BF 8A C4 OUT PORT_A,AL ;OUTPUT PORT DATA TO 8042
03C1 E6 60 CALL EMPTY_8042 ;WAIT FOR 8042 TO ACCEPT PORT DATA
03C3 E8 03C7 R
;
;----- 8042 OUTPUT WILL SWITCH WITHIN 20 USEC OF ACCEPTING PORT DATA -----
03C6 GATE_A20_RETURN:
03C6 03 RET
-----
EMPTY_8042
; THIS ROUTINE WAITS FOR THE 8042 INPUT BUFFER TO EMPTY.
; INPUT
; NONE
; OUTPUT
; (AL)=0 8042 INPUT BUFFER EMPTY (ZERO FLAG SET)
; (AL)=2 TIME OUT, 8042 INPUT BUFFER FULL (NON-ZERO FLAG SET)
-----
EMPTY_8042:
03C7 PUSH CX ;SAVE CX
03C7 51 SUB CX,CX ;CX=0, WILL BE USED AS TIME OUT VALUE
03C8 2B C9 EMPTY_LOOP:
03CA IN AL,STATUS_PORT ;READ 8042 STATUS PORT
03CA E4 64 AND AL,INPT_BUF_FULL;TEST INPUT BUFFER FULL FLAG (BIT 1)
03CC 24 02 LOOPNZ EMPTY_LOOP ;LOOP UNTIL INPUT BUFFER EMPTY OR TIME OUT
03CE E0 FA POP CX ;RESTORE CX
03D0 59 RET
03D1 C3
GATE_A20 ENDP
PAGE
----- INT 15 (FUNCTION 88H - IO MEMORY SIZE DETERMINE) -----
; EXT_MEMORY
; THIS ROUTINE RETURNS THE AMOUNT OF MEMORY IN THE
; SYSTEM THAT IS LOCATED STARTING AT THE 1024K ADDRESSING
; RANGE, AS DETERMINED BY THE POST ROUTINES.
; NOTE THAT THE SYSTEM MAY NOT BE ABLE TO USE I/O MEMORY
; UNLESS THERE IS A FULL COMPLEMENT OF 512K OR 640 BYTES
; ON THE PLANAR. THIS SIZE IS STORED IN CMOS AT ADDRESS
; 30 AND 31.
; INPUT
; AH = 88H
;
; THE IO MEMORY SIZE VARIABLE IS SET DURING POWER ON
; DIAGNOSTICS ACCORDING TO THE FOLLOWING ASSUMPTIONS:
;
; 3. ALL INSTALLED MEMORY IS FUNCTIONAL.
;
; 4. ALL MEMORY FROM 0 TO 640K MUST BE CONTIGUOUS.
;
; OUTPUT
; (AX) = NUMBER OF CONTIGUOUS 1K BLOCKS OF MEMORY A
; AVAILABLE STARTING AT ADDRESS 1024k.
-----
EXT_MEMORY PROC
03D2 STI ; INTERRUPTS BACK ON
03D2 FB MOV AL,31H ; GET THE HIGH BYTE OF IO MEMORY
03D3 80 31 OUT CMOS_PORT,AL ;
03D5 E6 70 JMP SHORT $+2 ; IO DELAY
03D7 E6 00 IN AL,CMOS_PORT+1 ;
03D9 E4 71 XCHG AL,AH ; PUT HIGH BYTE IN POSITION (AH)
03DB 86 C4 MOV AL,30H ; GET THE LOW BYTE OF IO MEMORY
03DD 80 30 OUT CMOS_PORT,AL ;
03DF E6 70

```

03E1 EB 00
03E3 E4 71
03E5 CF
03E6

```
JMP SHORT S+2 ; IO DELAY  
IN AL,CMOS_PORT+1  
IRET ; RETURN TO USER  
ENDP
```

EXT MEMORY PAGE
INT 15H (FUNCTION 89H)

PURPOSE:
THIS BIOS FUNCTION PROVIDES A MEANS TO THE USER TO SWITCH INTO VIRTUAL (PROTECTED) MODE. UPON COMPLETION OF THIS FUNCTION THE PROCESSOR WILL BE IN VIRTUAL (PROTECTED) MODE AND CONTROL WILL BE TRANSFERRED TO THE CODE SEGMENT THAT WAS SPECIFIED BY THE USER.

ENTRY REQUIREMENTS:

ES:SI POINTS TO A DESCRIPTOR TABLE (GDT) BUILT BEFORE INTERRUPTING TO THIS FUNCTION. THESE DESCRIPTORS ARE USED BY THIS FUNCTION TO INITIALIZE THE IDTR, THE GDTR AND THE STACK SEGMENT SELECTOR. THE DATA SEGMENT (DS) SELECTOR AND THE EXTRA SEGMENT (ES) SELECTOR WILL BE INITIALIZE TO DESCRIPTORS BUILT BY THE ROUTINE USING THIS FUNCTION.
BH - OFFSET INTO THE INTERRUPT DESCRIPTOR TABLE STATING WHERE THE FIRST EIGHT HARDWARE INTERRUPTS WILL BEGIN. (INTERRUPT LEVEL 1)
BL - OFFSET INTO THE INTERRUPT DESCRIPTOR TABLE STATING WHERE THE SECOND EIGHT HARDWARE INTERRUPTS WILL BEGIN. (INTERRUPT LEVEL 2)

THE DESCRIPTORS ARE DEFINED AS FOLLOWS:

1. THE FIRST DESCRIPTOR IS THE REQUIRED DUMMY. (USER INITIALIZED TO 0)
2. THE SECOND DESCRIPTOR POINTS TO THE GDT TABLE AS A DATA SEGMENT. (USER INITIALIZED)
3. THE THIRD DESCRIPTOR POINTS TO THE USER DEFINED INTERRUPT DESCRIPTOR TABLE (IDT). (USER INITIALIZED)
4. THE FORTH DESCRIPTOR POINTS TO THE USER'S DATA SEGMENT (DS). (USER INITIALIZED)
5. THE FIFTH DESCRIPTOR POINTS TO THE USER'S EXTRA SEGMENT (ES). (USER INITIALIZED)
6. THE SIXTH DESCRIPTOR POINTS TO THE USER'S STACK SEGMENT (SS). (USER INITIALIZED)
7. THE SEVENTH DESCRIPTOR POINTS TO THE CODE SEGMENT THAT THIS FUNCTION WILL RETURN TO. (USER INITIALIZED TO THE USER'S CODE SEGMENT.)
8. THE EIGHTH DESCRIPTOR IS USED BY THIS FUNCTION TO ESTABLISH A CODE SEGMENT FOR ITSELF. THIS IS NEEDED SO THAT THIS FUNCTION CAN COMPLETE IT'S EXECUTION WHILE IN PROTECTED MODE. WHEN CONTROL GETS PASSED TO THE USER'S CODE THIS DESCRIPTOR CAN BE USED BY HIM IN ANY WAY HE CHOOSES.

NOTE - EACH DESCRIPTOR MUST CONTAIN ALL THE NECESSARY DATA I.E. THE LIMIT, BASE ADDRESS AND THE ACCESS RIGHTS BYTE.

AH=88H (FUNCTION CALL)
ES:SI = LOCATION OF THE GDT TABLE BUILT BY ROUTINE USING THIS FUNCTION.

EXIT PARAMETERS:

AH = 0 IF SUCCESSFUL
ALL SEGMENT REGISTERS ARE CHANGED, AX AND BP DESTROYED

CONSIDERATIONS:

1. NO BIOS AVAILABLE TO USER. USER MUST HANDLE ALL IO COMMANDS.
2. INTERRUPTS - INTERRUPT VECTOR LOCATIONS MUST BE MOVED, DUE TO THE 286 RESERVED AREAS, THE HARDWARE INTERRUPT CONTROLLERS MUST BE REINITIALIZED TO DEFINE LOCATIONS THAT DO NOT RESIDE IN THE 286 RESERVED AREAS.
3. EXCEPTION INTERRUPT TABLE AND HANDLER MUST BE INITIALIZED BY THE USER.
4. THE INTERRUPT DESCRIPTOR TABLE MUST NOT OVERLAP THE REAL MODE BIOS INTERRUPT DESCRIPTOR TABLE.
5. THE FOLLOWING GIVES AN IDEA OF WHAT THE USER CODE SHOULD LOOK LIKE WHEN INVOKING THIS FUNCTION.

```
Real mode ----> "USER CODE"  
" MOV AX,GDT SEGMENT  
" MOV ES,AX  
" MOV SI,GDT OFFSET  
" MOV BH,HARDWARE INT LEVEL 1 OFFSET  
" MOV BL,HARDWARE INT LEVEL 2 OFFSET  
" MOV AH,88H  
" INT 15H  
Virtual mode ----> "USER CODE"
```

DESCRIPTION:

1. CLI (NO INTERRUPTS ALLOWED) WHILE THIS FUNCTION IS EXECUTING.
2. ADDRESS LINE 20 IS GATED ACTIVE.
3. THE CURRENT USER STACK SEGMENT DESCRIPTOR IS INITIALIZED.
4. THE GDTR IS LOADED WITH THE GDT BASE ADDRESS.
5. THE IDTR IS LOADED WITH THE IDT BASE ADDRESS.
6. THE 8259 IS REINITIALIZED WITH THE NEW INTERRUPT OFFSETS.
7. THE PROCESSOR IS PUT IN VIRTUAL MODE WITH THE CODE SEGMENT DESIGNATED FOR THIS FUNCTION.
8. DATA SEGMENT IS LOADED WITH THE USER DEFINED SELECTOR FOR THE DS REGISTER.
9. EXTRA SEGMENT IS LOADED WITH THE USER DEFINED SELECTOR FOR THE ES REGISTER
10. STACK SEGMENT IS LOADED WITH THE USER DEFINED SELECTOR FOR THE SS REGISTER
11. CODE SEGMENT DESCRIPTOR SELECTOR VALUE IS SUBSTITUTED ON THE STACK FOR RETURN TO USER.
12. WE TRANSFER CONTROL TO THE USER WITH INTERRUPTS DISABLED.

page

THE FOLLOWING DIAGRAM DEPICTS THE ORGANIZATION OF GDT.

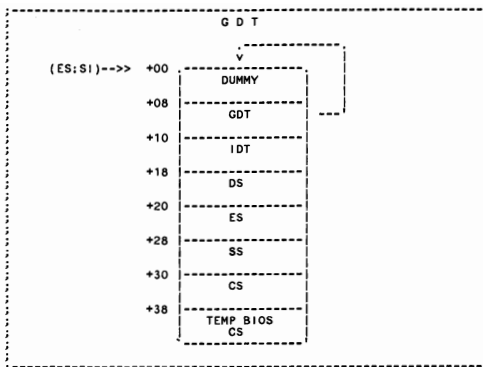

THE GLOBAL DESCRIPTOR TABLE (ACTUAL LOCATION POINTED TO BY ES:SI)

```

VIRTUAL_ENABLE_GDT_DEF  STRUC
0000  00 00 00 00 00 00    DUMMY  DQ  0          ; FIRST DESCRIPTOR NOT ACCESSIBLE
0008  00 00 00 00 00 00    GDTPTR DQ  0          ; GDT DESCRIPTOR
0010  00 00 00 00 00 00    IDTPTR DQ  0          ; IDT DESCRIPTOR
0018  00 00 00 00 00 00    USER_DS DQ  0        ; USER DATA SEGEMNT DESCRIPTOR
0020  00 00 00 00 00 00    USER_ES DQ  0        ; USER EXTRA SEGMENT DESCRIPTOR
0028  00 00 00 00 00 00    USER_SS DQ  0        ; USER STACK SEGMENT DESCRIPTOR
0030  00 00 00 00 00 00    USER_CS DQ  0        ; USER CODE SEGMENT DESCRIPTOR
0038  00 00 00 00 00 00    BIO_CS  DQ  0        ; TEMPORARY BIOS DESCRIPTOR
0040                                VIRTUAL_ENABLE_GDT_DEF  ENDS
;-----
                                ASSUME  CS:CODE
                                ASSUME  DS:DATA
03E6                                X_VIRTUAL
03E6                                SET_VMODE:
03E6  FA                                CLI                                ; NO INTERRUPTS ALLOWED
;-----  ENABLE ADDRESS LATCH BIT 20
03E7  B4 DF                                MOV    AH,ENABLE_BIT20          ; ENABLE BIT 20 FOR ADDRESS GATE
03E9  E8 03B0 R                            CALL  GATE_A20                  ; GATE A20
03EC  3C 00                                CMP    AL,0                     ; WAS THE COMMAND ACCEPTED?
03EE  74 04                                JZ     BIT20_ON                 ; GO IF YES
03F0  B4 FF                                MOV    AH,OFFH                 ; SET THE ERROR FLAG
03F2  F9                                STC                                ; SET CARRY
03F3  CF                                IRET                             ; EARLY EXIT
03F4                                BIT20_ON:
03F4  26                                SEGOV DB 026H                  ; LOAD THE GLOBAL DESCRIPTOR TABLE REG
+                                DB  [SI].GDTPTR
+                                LGDT [SI].GDTPTR
+                                LABEL BYTE
+ ????015 LABEL MOV DX,WORD PTR [SI].GDTPTR
+ ????016 LABEL ORG OFFSET CS:????015
+                                DB 001H
+                                ORG  OFFSET CS:????016
03F9  26                                SEGOV DB 026H                  ; LOAD THE INTERRUPT DESCRIPTOR TABLE REG
+                                DB  [SI].IDTPTR
+                                LABEL BYTE
+ ????018 LABEL MOV BX,WORD PTR [SI].IDTPTR
+ ????019 LABEL ORG OFFSET CS:????018
+                                DB 001H
+                                ORG  OFFSET CS:????019
;-----
REINITIALIZE THE 8259 INTERRUPT CONTROLLER #1 TO THE USER SPECIFIED OFFSET I
03FE  B0 11                                MOV    AL,11H                  ; START INITIALIZATION SEQUENCE-ICW1
0400  E6 20                                OUT    INTA00,AL               ; EDGE, INTERVAL-8,MASTER,ICW4 NEEDED
0402  E8 00                                JMP    SHORT $+2               ;
0404  8A C7                                MOV    AL,BH                   ; HARDWARE INT'S START AT INT # (BH)
0406  E6 21                                OUT    INTA01,AL               ; SEND ICW2
0408  E8 00                                JMP    SHORT $+2               ;
040A  B0 04                                MOV    AL,04H                 ; SEND ICW3 - MASTER LEVEL 2
040C  E6 21                                OUT    INTA01,AL               ;
040E  E8 00                                JMP    SHORT $+2               ;
0410  B0 01                                MOV    AL,01H                 ; SEND ICW4 - MASTER,8086 MODE
0412  E6 21                                OUT    INTA01,AL               ;
0414  E8 00                                JMP    SHORT $+2               ;
0416  B0 FF                                MOV    AL,OFFH                 ; MASK OFF ALL INTERRUPTS
0418  E6 21                                OUT    INTA01,AL               ;
;-----
REINITIALIZE THE 8259 INTERRUPT CONTROLLER #2 TO THE USER SPECIFIED OFFSET I
041A  B0 11                                MOV    AL,11H                  ; START INIT SEQUENCE-ICW1 FOR SLAVE

```

```

041C E6 A0          OUT     INTB00,AL          ; EDGE, INTERVAL-8, MASTER, ICW4 NEEDED
041E EB 00          JMP     SHORT $+2
0420 8A C3          MOV     AL,BL             ; HARDWARE INT'S START AT INT # (BL)
0422 E6 A1          OUT     INTB01,AL        ; SEND ICW2
0424 B0 02          MOV     AL,02H           ;
0426 EB 00          JMP     SHORT $+2
0428 E6 A1          OUT     INTB01,AL        ;
042A EB 00          JMP     SHORT $+2
042C B0 01          MOV     AL,01H           ; SEND ICW3 - SLAVE LEVEL 2
042E E6 A1          OUT     INTB01,AL        ;
0430 EB 00          JMP     SHORT $+2
0432 B0 FF          MOV     AL,0FFH          ; SEND ICW4 - SLAVE, 8086 MODE
0434 E6 A1          OUT     INTB01,AL        ; MASK OFF ALL INTERRUPTS

```

```

-----
; SETUP BIOS CODE SEGMENT DESCRIPTOR
-----

```

```

0436 26: C7 44 38 FFFF      MOV     ES:[SI],BIO_CS.SEG_LIMIT,MAX_SEG_LEN ; SET LENGTH
043C 26: C6 44 3C 0F      MOV     ES:[SI],BIO_CS.BASE_HI_BYTE,CSEG@_HI ; SET HIGH BYTE OF CS=0F
0441 26: C7 44 3A 0000      MOV     ES:[SI],BIO_CS.BASE_LO_WORD,CSEG@_LO ; SET LOW WORD OF CS=0
0447 26: C6 44 3D 9B      MOV     ES:[SI],BIO_CS.DATA_ACC_RIGHTS,CPLD_CODE_ACCESS ; SET ACCESS RIGHTS BYTE
044C 26: C7 44 3E 0000      MOV     ES:[SI],BIO_CS.DATA_RESERVED,0 ; ZERO RESERVED AREA

```

```

-----
; ENABLE PROTECTED MODE
-----

```

```

0452 B8 0001          MOV     AX,VIRTUAL_ENABLE ; MACHINE STATUS WORD NEEDED TO
0455 0F                + LMSW  AX                ; SWITCH TO VIRTUAL MODE
0456                + DB     00FH
0456                + LABEL BYTE
0456 8B F0            + MOV     SI,AX
0458                + LABEL BYTE
0456                + ORG    OFFSET CS:??001A
0456 01                + DB     001H
0458                + ORG    OFFSET CS:??001B
0458 EA                + JUMPFAR VMODE,BIO_CS ; MUST PURGE PRE-FETCH QUEUE
0459 045D R          + DB     0EAH ; Jump far direct
045B 0038            + DW     (OFFSET VMODE) ; to this offset
0458                + DW     BIO_CS ; in this segment

```

```

VMODE:

```

```

-----
; SETUP USER SEGMENT REGISTERS
-----

```

```

045D B8 0018          MOV     AX,USER_DS        ; SETUP USER'S DATA SEGMENT
0460 8E D8            MOV     DS,AX
0462 B8 0020          MOV     AX,USER_ES        ; SETUP USER'S EXTRA SEGMENT
0465 8E C0            MOV     ES,AX
0467 B8 0028          MOV     AX,USER_SS        ; SETUP USER'S STACK SEGMENT
046A 8E D0            MOV     SS,AX

```

```

-----
; PUT TRANSFER ADDRESS ON THE STACK AND RETURN TO THE USER
-----

```

```

046C 5B                POP     BX                ; GET RETURN IP FROM THE STACK
046D 83 C4 04          ADD     SP,4              ; NORMALIZE STACK POINTER
0470 68                + IPUSH  USER_CS         ; SET STACK FOR A RETURN FAR
0471 0030            + DB     068H
0473 53                + DW     USER_CS
0474 CB                PUSH    BX
0474 CB                RET                        ; RETURN TO USER IN VIRTUAL MODE

```

```

0475 X_VIRTUAL        ENDP

```

```

-----
;--- DEVICE BUSY AND INTERRUPT COMPLETE -----
:
: THIS ROUTINE IS A TEMPORARY HANDLER FOR DEVICE BUSY
: AND INTERRUPT COMPLETE
:
: INPUT
: SEE PROLOG
:
-----

```

```

0475 DEVICE_BUSY    PROC    NEAR
0475 F8                CLC                        ; TURN CARRY OFF
0476 E9 004F R          JMP     C1_F                ; RETURN WITH CARRY FLAG
0479                ENDP
0479 INT_COMPLETE    PROC    NEAR
0479 CF                IRET                       ; RETURN
047A                ENDP
047A                CODE
047A                ENDS
047A                END

```

TITLE 08-08-83 B1052 BIOS INTERRUPT
 .LIST
 INCLUDE SEGMENT.SRC
 CODE SEGMENT BYTE PUBLIC
 C C C

0000

```

EXTRN DDS:NEAR
PUBLIC TIME_OF_DAY_1,TIMER_INT_1,PRINT_SCREEN_1
PUBLIC RTC_INT
;--- INT 1A ---
;-----
; TIME OF DAY
; THIS ROUTINE ALLOWS THE CLOCK TO BE SET/READ
;-----
INPUT
(AH) = 0 READ THE CURRENT CLOCK SETTING
          RETURNS CX = HIGH PORTION OF COUNT
          DX = LOW PORTION OF COUNT
          AL = 0 IF TIMER HAS NOT PASSED 24 HOURS
          SINCE LAST READ, < 0 IF ON ANOTHER DAY
(AH) = 1 SET THE CURRENT CLOCK
          CX = HIGH PORTION OF COUNT
          DX = LOW PORTION OF COUNT
NOTE: COUNTS OCCUR AT THE RATE OF 1193180/65536 COUNTS/SEC
      (OR ABOUT 18.2 PER SECOND -- SEE EQUATES)
(AH) = 2 READ THE REAL TIME CLOCK
          RETURNS CH = HOURS IN BCD
          CL = MINUTES IN BCD
          DH = SECONDS IN BCD
(AH) = 3 SET THE REAL TIME CLOCK
          CH = HOURS IN BCD
          CL = MINUTES IN BCD
          DH = SECONDS IN BCD
          DL = 1 IF DAYLIGHT SAVINGS TIME OPTION, ELSE 0
(AH) = 4 READ THE DATE FROM THE REAL TIME CLOCK
          RETURNS CH = CENTURY IN BCD (19 OR 20)
          CL = YEAR IN BCD
          DH = MONTH IN BCD
          DL = DAY IN BCD
(AH) = 5 SET THE DATE INTO THE REAL TIME CLOCK
          CH = CENTURY IN BCD (19 OR 20)
          CL = YEAR IN BCD
          DH = MONTH IN BCD
          DL = DAY IN BCD
(AH) = 6 SET THE ALARM
          THE ALARM CAN BE SET TO INTERRUPT UP TO
          23:59:59 FROM PRESENT TIME.
          ONE ALARM FUNCTION MAY BE ACTIVE AT ANY TIME
          CH = HOURS IN BCD
          CL = MINUTES IN BCD
          DH = SECONDS IN BCD
(AH) = 7 RESET THE ALARM
NOTE: FOR AH = 2, 4, 6 - CY FLAG SET IF CLOCK NOT OPERATING
NOTE: FOR THE ALARM FUNCTION (AH = 6) THE USER MUST CODE A
      ROUTINE AND PLACE THE CORRECT ADDRESS IN THE VECTOR
      TABLE FOR INT 4AH
;-----
ASSUME CS:CODE,DS:DATA

```

```

0000 TIME_OF_DAY_1 PROC FAR
0000 STI DS ; INTERRUPTS BACK ON
0001 FB PUSH DS ; SAVE SEGMENT
0002 E8 0000 E CALL DDS ; SET DATA SEGMENT
0005 0A E4 OR AH,AH ; AH=0
0007 74 14 JZ T2 ; READ_TIME
0009 FE CC DEC AH ; AH=1
000B 74 23 JZ T3 ; SET_TIME
000D 80 FC 07 CMP AH,7 ; CHECK IF VALID
0010 7D 03 JGE T1 ; RETURN IF NOT VALID
0012 EB 2C 90 JMP RTC_0 ; GO CHECK OTHER FUNCTIONS
0015 T1: ; TOD_RETURN
0015 FB ; INTERRUPTS BACK ON
0016 1F POP DS ; RECOVER SEGMENT
0017 CF IRET ; RETURN TO CALLER

0018 T1_A: ; SET ERROR RETURN
0018 F9 STC DS
0019 1F POP DS
001A CA 0002 RET 2

001D T2: ; READ_TIME
001D FA CLD ; NO TIMER INTERRUPTS WHILE READING
001E AD 0070 R MOV AL,TIMER_OFL ; TIMER_OFL,0
0021 C6 06 0070 R 00 MOV CX,TIMER_HIGH ; GET OVERFLOW, AND RESET THE FLAG
0026 8B 0E 006E R MOV DX,TIMER_LOW
002A 8B 16 006C R MOV T1
002E EB E5 JMP T1 ; TOD_RETURN

0030 T3: ; SET_TIME
0030 FA CLD ; NO INTERRUPTS WHILE WRITING
0031 89 16 006C R MOV TIMER_LOW,DX
0035 89 0E 006E R MOV TIMER_HIGH,CX ; SET THE TIME
0039 C6 06 0070 R 00 MOV TIMER_OFL,0 ; RESET OVERFLOW
003E EB 05 JMP T1 ; TOD_RETURN

0040 RTC_0:
0040 FE CC DEC AH ; AH = 2
0042 74 07 JZ RTC_2 ; READ RTC TIME
0044 FE CC DEC AH ; AH = 3
0046 74 26 JZ RTC_3 ; SET RTC TIME
0048 E9 0007 R JMP RTC_1 ; GO CHECK REMAINING FUNCTIONS
004B RTC_GET_TIME PROC NEAR

004B RTC_2:
004B E8 01B7 R CALL UPD_IN_PR ; CHECK FOR UPDATE IN PROCESS
004E 73 02 JNC RTC_2A ; GO AROUND IF OK
0050 EB C6 JMP T1_A ; RETURN IF ERROR

0052 RTC_2A:
0052 FA CLD ; INTERRUPTS OFF DURING READ
0053 B2 FE MOV DL,-2
0055 E8 0192 R CALL PORT_INC_2 ; PORT_INC_2
0058 E4 71 IN AL,CMOS_PORT+1 ; SET ADDRESS OF SECONDS
005A 8A F0 MOV DH,AL ; SAVE
005C E8 0192 R CALL PORT_INC_2 ; SET ADDRESS OF MINUTES
005F E4 71 IN AL,CMOS_PORT+1 ; SAVE
0061 8A C8 MOV CL,AL ; SAVE
0063 E8 0192 R CALL PORT_INC_2 ; SET ADDRESS OF HOURS
0066 E4 71 IN AL,CMOS_PORT+1 ;

```

SECTION 5

```

0068 8A E8          MOV     CH,AL          ; SAVE
006A B2 00          MOV     DL,0          ; SET DL TO ZERO
006C EB A7          JMP     T1            ; RETURN
006E              RTC_GET_TIME
;
006E              RTC_SET_TIME
RTC_3:          PROC    NEAR
;
006E              CALL    UPD_IN_PR          ; CHECK FOR UPDATE IN PROCESS
0071 73 03          JNC     RTC_3A       ; GO AROUND IF CLOCK OPERATING
0073 EB 019A R     CALL    INITIALIZE_STATUS
0076              RTC_3A:
0076 FA            CLI            ; INTERRUPTS OFF DURING SET
0077 92            PUSH           DX          ; SAVE
0078 B2 FE          MOV     DL,-2        ; FIRST ADDRESS
007A E8 0192 R     CALL    PORT_INC_2    ; UPDATE ADDRESS
007D 8A C6          MOV     AL,DH        ; GET TIME BYTE - SECONDS
007F E6 71          OUT     CMOS_PORT+1,AL ; STORE TIME BYTE
0081 E8 0192 R     CALL    PORT_INC_2    ; UPDATE ADDRESS
0084 8A C1          MOV     AL,CL        ; GET TIME BYTE - MINUTES
0086 E6 71          OUT     CMOS_PORT+1,AL ; STORE TIME BYTE
0088 EB 0192 R     CALL    PORT_INC_2    ; UPDATE ADDRESS
008B 8A C5          MOV     AL,CH        ; GET TIME BYTE - HOURS
008D E6 71          OUT     CMOS_PORT+1,AL ; STORE TIME BYTE
008F B2 0A          MOV     DL,0AH       ;
0091 E8 018B R     CALL    PORT_INC     ;
0094 5A            POP      DX          ; RESTORE
0095 E4 71          IN     AL,CMOS_PORT+1 ; GET CURRENT VALUE
0097 24 23          AND     AL,23H       ; MASK FOR VALID BIT POSITIONS
0099 0A C2          OR     AL,DL         ; GET DST BIT
009B 0C 02          OR     AL,02H        ; TURN ON 24 HR MODE
009D 50            PUSH          AX          ;
009E B2 0A          MOV     DL,0AH       ;
00A0 E8 018B R     CALL    PORT_INC     ;
00A3 58            POP      AX          ;
00A5 E6 71          OUT     CMOS_PORT+1,AL ;
00A7 E9 0015 R     JMP     T1            ; DONE
00A9              RTC_SET_TIME
;
00A9              RTC_GET_DATE
RTC_4:          PROC    NEAR
;
00A9              CALL    UPD_IN_PR          ; CHECK FOR UPDATE IN PROCESS
00AC 73 03          JNC     RTC_4A       ; GO AROUND IF CLOCK OPERATING
00AE E9 0018 R     JMP     T1_A         ; RETURN ON ERROR
00B1              RTC_4A:
00B1 FA            CLI            ; INTERRUPTS OFF DURING READ
00B2 B2 06          MOV     DL,6         ;
00B4 E8 018B R     CALL    PORT_INC     ; POINT TO DAY
00B7 E4 71          IN     AL,CMOS_PORT+1 ;
00B9 8A E8          MOV     CH,AL        ; SAVE
00BB EB 018B R     CALL    PORT_INC     ; POINT TO MONTH
00BE E4 71          IN     AL,CMOS_PORT+1 ;
00C0 8A F0          MOV     DH,AL        ; SAVE
00C2 EB 018B R     CALL    PORT_INC     ; POINT TO YEAR
00C5 E4 71          IN     AL,CMOS_PORT+1 ;
00C7 8A C8          MOV     CL,AL        ; SAVE
00C9 B2 31          MOV     DL,31H       ; POINT TO CENTURY BYTE SAVE AREA
00CB EB 018B R     CALL    PORT_INC     ;
00CE E4 71          IN     AL,CMOS_PORT+1 ; GET VALUE
00D0 8A D5          MOV     DL,CH        ; GET DAY BACK
00D2 8A E8          MOV     CH,AL        ;
00D4 E9 0015 R     JMP     T1            ; FINISHED
00D7              RTC_GET_DATE
RTC_1:          PROC    NEAR
;
00D7              DEC     AH            ; AH = 4
00D9 74 CC          JZ     RTC_4         ; READ RTC DATE
00DB FE CC          DEC     AH            ; AH = 5
00DD 74 07          JZ     RTC_5         ; SET RTC DATE
00DF FE CC          DEC     AH            ; AH = 6
00E1 74 45          JZ     RTC_6         ; SET RTC ALARM
00E3 E9 0175 R     JMP     RTC_7        ; RESET RTC ALARM
;
00E6              RTC_SET_DATE
RTC_5:          PROC    NEAR
;
00E6              CALL    UPD_IN_PR          ; CHECK FOR UPDATE IN PROCESS
00E9 73 03          JNC     RTC_5A       ; GO AROUND IF CLOCK UPDATING
00EB E8 019A R     CALL    INITIALIZE_STATUS
00EE              RTC_5A:
00EE FA            CLI            ; INTERRUPTS OFF DURING SET
00EF 51            PUSH           CX          ; SAVE
00F0 8A EA          MOV     CH,DL        ; SAVE DAY OF MONTH
00F2 B2 05          MOV     DL,5         ; ADDRESS OF DAY OF WEEK REGISTER
00F4 EB 018B R     CALL    PORT_INC     ;
00F7 B0 00          MOV     AL,00H       ;
00F9 E6 71          OUT     CMOS_PORT+1,AL ; LOAD ZEROS TO 'DAY OF WEEK' BYTE
00FB EB 018B R     CALL    PORT_INC     ; ADDRESS OF DAY OF MONTH REGISTER
00FE B4 C5          MOV     AL,CH        ; GET DAY OF MONTH BYTE
0100 E6 71          OUT     CMOS_PORT+1,AL ; STORE IT
0102 EB 018B R     CALL    PORT_INC     ; ADDRESS MONTH REGISTER
0105 8A C6          MOV     AL,DH        ; GET MONTH BYTE
0107 E6 71          OUT     CMOS_PORT+1,AL ; STORE IT
0109 EB 018B R     CALL    PORT_INC     ; ADDRESS OF YEAR REGISTER
010C 8A C1          MOV     AL,CL        ; GET YEAR BYTE
010E EB 018B R     CALL    PORT_INC     ; STORE IT
0110 B2 0A          MOV     DL,0AH       ;
0112 EB 018B R     CALL    PORT_INC     ;
0115 E4 71          IN     AL,CMOS_PORT+1 ; GET CURRENT SETTING
0117 24 7F          AND     AL,7FH       ; CLEAR 'SET BIT'
0119 E6 71          OUT     CMOS_PORT+1,AL ; *AND START CLOCK UPDATING
011B 59            POP      CX          ; GET BACK
011C B2 31          MOV     DL,31H       ; POINT TO SAVE AREA
011E EB 018B R     CALL    PORT_INC     ;
0121 8A C5          MOV     AL,CH        ; GET CENTURY BYTE
0123 E6 71          OUT     CMOS_PORT+1,AL ; SAVE IT
0125 E9 0015 R     JMP     T1            ; RETURN
0128              RTC_SET_DATE
;
0128              RTC_SET_ALARM
RTC_6:          PROC    NEAR
;
0128 B2 0A          MOV     DL,0AH       ; CHECK FOR ALARM ALREADY ENABLED
012A EB 018B R     CALL    PORT_INC     ;
012D E4 71          IN     AL,CMOS_PORT+1 ; GET CURRENT SETTING OF ALARM ENABLE
012F A8 20          TEST    AL,20H       ;
0131 74 05          JZ     RTC_6A       ; ALARM NOT SET - GO PROCESS
0133 33 C0          XOR     AX,AX        ;
0135 E9 0018 R     JMP     T1_A         ; RETURN IF ERROR
0138              RTC_6A:
0138 E8 01B7 R     CALL    UPD_IN_PR          ; CHECK FOR UPDATE IN PROCESS
013B 73 03          JNC     RTC_6B       ; GO AROUND IF CLOCK OPERATING
013D EB 019A R     CALL    INITIALIZE_STATUS
0140              RTC_6B:
0140 FA            CLI            ; INTERRUPTS OFF DURING SET
0141 B2 FF          MOV     DL,-1        ;
0143 E8 0192 R     CALL    PORT_INC_2    ;
0146 8A C6          MOV     AL,DH        ; GET SECONDS BYTE
0148 E6 71          OUT     CMOS_PORT+1,AL ; LOAD ALARM BYTE - SECONDS

```

```

0144 E8 0192 R CALL PORT_INC_2
014D 8A C1 MOV AL,CL ; GET MINUTES PARAMETER
014E E6 71 OUT CMOS_PORT+1,AL ; LOAD ALARM BYTE - MINUTES
0151 E8 0192 R CALL PORT_INC_2
0154 8A C5 MOV AL,CH ; GET HOURS PARAMETER
0156 E6 71 OUT CMOS_PORT+1,AL ; LOAD ALARM BYTE - HOURS
0158 E4 A1 IN AL,0A1H ; ENSURE INTERRUPT UNMASKED
015A 24 FE AND AL,0FEH ;
015C E6 A1 OUT 0A1H,AL ;
015E B2 0A MOV DL,0AH ;
0160 E8 018B R CALL PORT_INC
0163 E4 71 IN AL,CMOS_PORT+1 ; GET CURRENT VALUE
0165 24 7F AND AL,07FH ; ENSURE SET BIT TURNED OFF
0167 0C 20 OR AL,20H ; TURN ON ALARM ENABLE
0169 50 PUSH AX ;
016A B2 0A MOV DL,0AH ;
016C E8 018B R CALL PORT_INC
016F 58 POP AX ;
0170 E6 71 OUT CMOS_PORT+1,AL ; ENABLE ALARM
0172 E9 0015 R JMP T1
0175 RTC_SET_ALARM ENDP

0175 RTC_RESET_ALARM PROC NEAR
0175 RTC_7: CLI ; INTERRUPTS MASKED DURING RESET
0176 B2 0A MOV DL,0AH ;
0178 E8 018B R CALL PORT_INC
017B E4 71 IN AL,CMOS_PORT+1 ; GET STATUS BYTE
017D 24 57 AND AL,57H ; TURN OFF ALARM ENABLE
017F 50 PUSH AX ; SAVE
0180 B2 0A MOV DL,0AH ;
0182 E8 018B R CALL PORT_INC ;
0185 58 POP AX ;
0186 E6 71 OUT CMOS_PORT+1,AL ; RESTORE
0188 E9 0015 R JMP T1
018B RTC_RESET_ALARM ENDP

0188 RTC_TIMEBIO5_SUBR PROC NEAR
0188 PORT_INC: INC DL ; INCREMENT ADDRESS
018D 8A C2 MOV AL,DL ;
018F E6 70 OUT CMOS_PORT,AL ;
0191 C3 RET ;

;
0192 PORT_INC_2: ADD DL,2 ; INCREMENT ADDRESS
0195 8A C2 MOV AL,DL ;
0197 E6 70 OUT CMOS_PORT,AL ;
0199 C3 RET ;

;
019A INITIALIZE_STATUS PROC NEAR
;
019A 52 PUSH DX ; SAVE
019B B2 09 MOV DL,09H ;
019D E8 018B R CALL PORT_INC
01A0 B0 26 MOV AL,26H ;
01A2 E6 71 OUT CMOS_PORT+1,AL ; INITIALIZE 'A' REGISTER
01A4 E8 018B R CALL PORT_INC ;
01A7 B0 82 MOV AL,82H ; SET 'SET BIT' FOR CLOCK INITIALIZATION
; AND 24 HOUR MODE
01A9 E6 71 OUT CMOS_PORT+1,AL ; INITIALIZE 'B' REGISTER
01AB E8 018B R CALL PORT_INC ;
01AE E4 71 IN AL,CMOS_PORT+1 ; READ REGISTER 'C' TO INITIALIZE
01B0 E8 018B R CALL PORT_INC ;
01B3 E4 71 IN AL,CMOS_PORT+1 ; READ REGISTER 'D' TO INITIALIZE
01B5 5A POP DX ; RESTORE
01B6 C3 RET ;

;
01B7 INITIALIZE_STATUS ENDP

01B7 UPD_IN_PR:
01B7 51 PUSH CX
01B8 B9 0258 MOV CX,600 ; SET LOOP COUNT
01BB UPDATE: MOV AL,0AH ; ADDRESS OF 'A' REGISTER
01BD E6 70 OUT CMOS_PORT,AL ;
01BF EB 00 JMP $+2 ; I/O TIME DELAY
01C1 E4 71 IN AL,CMOS_PORT+1 ; READ IN REGISTER 'A'
01C3 A9 80 TEST AL,80H ; IF 8XH--> UIP BIT IS ON (CANNOT READ TIM
01C5 74 05 JZ UPD_IN_PREND ;
01C7 E2 F0 LOOP UPDATE ;
01C9 33 C0 XOR AX,AX ;
01CB STC ; SET CARRY FOR ERROR
01CC UPD_IN_PREND: POP CX
01CD C3 RET ; RETURN

;
01CE RTC_TIMEBIO5_SUBR ENDP
01CE TIME_OF_DAY_1 ENDP
PAGE
;-- INT 50 (LEVEL 8)-----;
; THIS ROUTINE HANDLES THE PERIODIC AND ALARM INTERRUPTS FROM ;
; THE NON-VOLATILE TIMER. INPUT FREQUENCY IS 1,024 KHZ ;
; OR APPROXIMATELY 1024 INTERRUPTS EVERY SECOND FOR THE ;
; PERIODIC INTERRUPT. FOR THE ALARM FUNCTION, AN INTERRUPT WILL ;
; OCCUR AT THE DESIGNATED TIME. ;
; ;
; THE INTERRUPT IS ENABLED ONLY WHEN EVENT OR ALARM FUNCTIONS ;
; ARE ACTIVE ;
; FOR THE EVENT INTERRUPT, THE HANDLER WILL DECREMENT THE ;
; WAIT COUNTER AND WHEN IT EXPIRES WILL TURN ON THE HIGH ORDER ;
; BIT OF THE DESIGNATED FLAG. ;
; FOR THE ALARM INTERRUPT, THE USER ROUTINE WILL BE INVOKED ;
; THROUGH INT 5AH. THE USER MUST CODE A ROUTINE AND PLACE THE ;
; CORRECT ADDRESS IN THE VECTOR TABLE. ;
-----;

01CE RTC_INT PROC FAR
01CE FB STI ; INTERRUPTS BACK ON
01CF 1E PUSH DS ; SAVE REGISTERS
01D0 50 PUSH AX ;
01D1 52 PUSH DX ;
01D2 57 PUSH DI ;
01D3 B2 0A MOV DL,0AH ; GET ENABLES
01D5 E8 018B R CALL PORT_INC
01D8 E4 71 IN AL,CMOS_PORT+1 ;
01DA 8A E0 MOV AH,AL ; SAVE
01DC E8 018B R CALL PORT_INC ; GET SOURCE
01DF E4 71 IN AL,CMOS_PORT+1 ;
01E1 22 C4 AND AL,AH ;
01E3 50 PUSH AX ; SAVE
01E4 A8 40 TEST AL,0A0H ; CHECK FOR PERIODIC INTERRUPT
01E6 74 2E JZ RTC_INT_9 ; NO - GO AROUND
01E8 E8 0000 E CALL DDS ; ESTABLISH ADDRESSABILITY
01EB 81 2E 009C R 03D0 SUB RTC_LOW,0976 ; DECREMENT COUNT
01F1 83 1E 009E R 00 SBB RTC_HIGH,0 ;
01F6 77 1E JA RTC_INT_9 ;

```

```

01F8 B2 0A      MOV DL,0AH      ; TURN OFF PIE
01FA E8 018B R   CALL PORT_INC   ;
01FD E4 71      IN AL,CMOS_PORT+1
01FF 24 BF      AND AL,0BFH
0201 50          PUSH AX
0202 B2 0A      MOV DL,0AH      ;
0204 E8 018B R   CALL PORT_INC   ;
0207 58          POP AX
0208 E6 71      MOV CMOS_PORT+1,AL
020A C6 06 00A0 R OUT RTC_WAIT_FLAG,0 ; SET FUNCTION ACTIVE FLAG OFF
020F C5 3E 0098 R LDS DI,DWORD PTR USER_FLAG ; SET UP DS:DI TO POINT TO USER FLAG
0213 C6 05 80      MOV BYTE PTR[DI],80H ; TURN ON USERS FLAG

```

```

0216          RTC_INT_9:
0216 58          POP AX          ; GET INTERRUPT SOURCE BACK
0217 A8 20      TEST AL,20H     ; TEST FOR ALARM INTERRUPT
0219 74 02      JZ RTC_INT_10  ; NO - GO AROUND
021B CD 4A      INT 4AH        ; TRANSFER TO USER ROUTINE
021D          RTC_INT_10:
021D 80 20      MOV AL,E01     ; END OF INTERRUPT TO 8259 - 2
021F E6 A0      OUT 0A0H,AL   ;
0221 E6 20      OUT 020H,AL   ; AND TO 8259 - 1
0223 5F          POP DI        ; RESTORE REGISTERS
0224 5A          POP DX
0225 58          POP AX
0226 1F          POP DS
0227 CF          IRET      ; END OF INTERRUPT
0228          RTC_INT_ENDP

```

```

PAGE
;--- INT 8 (LEVEL 0)-----;
; THIS ROUTINE HANDLES THE TIMER INTERRUPT FROM
; CHANNEL 0 OF THE 8253 TIMER. INPUT FREQUENCY IS 1,19318 MHZ ;
; AND THE DIVISOR IS 69536, RESULTING IN APPROX. 18.2 INTERRUPTS ;
; EVERY SECOND.
;
; THE INTERRUPT HANDLER MAINTAINS A COUNT OF INTERRUPTS SINCE ;
; POWER ON TIME, WHICH MAY BE USED TO ESTABLISH TIME OF DAY. ;
; THE INTERRUPT HANDLER ALSO DECREASES THE MOTOR CONTROL COUNT ;
; OF THE DISKETTE, AND WHEN IT EXPIRES, WILL TURN OFF THE ;
; DISKETTE MOTOR(S), AND RESET THE MOTOR RUNNING FLAGS. ;
; THE INTERRUPT HANDLER WILL ALSO INVOKE A USER ROUTINE THROUGH ;
; INTERRUPT ICH AT EVERY TIME TICK. THE USER MUST CODE A ;
; ROUTINE AND PLACE THE CORRECT ADDRESS IN THE VECTOR TABLE. ;
;-----;

```

```

0228          TIMER_INT_1 PROC FAR ; INTERRUPTS BACK ON
0228 FB          STI
0229 1E          PUSH DS
022A 50          PUSH AX
022B 52          PUSH DX        ; SAVE MACHINE STATE
022C E8 0000 E   CALL DDS      ; ESTABLISH ADDRESSABILITY
022F FF 06 006C R INC TIMER_LOW ; INCREMENT TIME
0233 75 04      JNZ T4       ; TEST_DAY
0235 FF 06 006E R INC TIMER_HIGH ; INCREMENT HIGH WORD OF TIME
0239          T4:
0239 83 3E 006E R 18 CMP TIMER_HIGH,018H ; TEST FOR COUNT EQUALLING 24 HOURS
023E 75 15      JNZ T5      ; DISKETTE_CTL
0240 81 3E 006C R 0080 CMP TIMER_LOW,0B0H ; DISKETTE_CTL
0246 75 0D      JNZ T5      ; DISKETTE_CTL

```

;----- TIMER HAS GONE 24 HOURS

```

0248 2B C0      SUB AX,AX
024A A3 006E R   MOV TIMER_HIGH,AX
024D A3 006C R   MOV TIMER_LOW,AX
0250 C6 06 0070 R 01 MOV TIMER_OFL,1

```

;----- TEST FOR DISKETTE TIME OUT

```

0255          T5:
0255 FE 0E 0040 R DEC MOTOR_COUNT ; DISKETTE_CTL
0259 75 08      JNZ T6       ; RETURN IF COUNT NOT OUT
025B 80 26 003F R FO AND MOTOR_STATUS,0F0H ; TURN OFF MOTOR RUNNING BITS
0260 80 0C      AND AL,0CH   ;
0262 BA 03F2    MOV DX,03F2H ; FDC CTL PORT
0265 EE          OUT DX,AL    ; TURN OFF THE MOTOR
0266          T6:
0266 CD 1C      INT 1CH     ; TIMER_RET:
0268 B0 20      MOV AL,E01  ; TRANSFER CONTROL TO A USER ROUTINE
026A E6 20      OUT 020H,AL ; END OF INTERRUPT TO 8259
026C 5A          POP DX
026D 58          POP AX
026E 1F          POP DS     ; RESET MACHINE STATE
026F CF          IRET ; RETURN FROM INTERRUPT
0270          TIMER_INT_1 ENDP

```

```

;--- INT 5 -----;
; THIS LOGIC WILL BE INVOKED BY INTERRUPT 05H TO PRINT
; THE SCREEN. THE CURSOR POSITION AT THE TIME THIS ROUTINE
; IS INVOKED WILL BE SAVED AND RESTORED UPON COMPLETION. THE
; ROUTINE IS INTENDED TO RUN WITH INTERRUPTS ENABLED.
; IF A SUBSEQUENT 'PRINT SCREEN KEY IS DEPRESSED DURING THE
; TIME THIS ROUTINE IS PRINTING IT WILL BE IGNORED.
; ADDRESS 50:0 CONTAINS THE STATUS OF THE PRINT SCREEN:
;
; 50:0 =0     EITHER PRINT SCREEN HAS NOT BEEN CALLED
;            OR UPON RETURN FROM A CALL THIS INDICATES
;            A SUCCESSFUL OPERATION.
;
;           =1     PRINT SCREEN IS IN PROGRESS
;
;           =255  ERROR ENCOUNTERED DURING PRINTING
;-----;
ASSUME CS:CODE,DS:XXDATA

```

```

0270          PRINT_SCREEN_1 PROC FAR ;
0270 FB          STI ; MUST RUN WITH INTERRUPTS ENABLED
0271 1E          PUSH DS ; MUST USE 50:0 FOR DATA AREA STORAGE
0272 50          PUSH AX
0273 53          PUSH BX
0274 51          PUSH CX ; WILL USE THIS LATER FOR CURSOR LIMITS
0275 52          PUSH DX ; WILL HOLD CURRENT CURSOR POSITION
0276 B8        MOV AX,XXDATA ; HEX 50
0279 8E D8      MOV DS,AX
027B 80 3E 0000 R 01 CMP STATUS_BYTE,1 ; SEE IF PRINT ALREADY IN PROGRESS
0280 74 5F      JZ EXIT ; JUMP IF PRINT ALREADY IN PROGRESS
0282 C5 06 0000 R 01 MOV STATUS_BYTE,1 ; INDICATE PRINT NOW IN PROGRESS
0287 B4 0F      MOV AH,15 ; WILL REQUEST THE CURRENT SCREEN MODE
0289 CD 10      INT 10H ; [AL]=MODE
; [AH]=NUMBER COLUMNS/LINE
; [BH]=VISUAL PAGE
; *****

```



```

; AT THIS POINT WE KNOW THE COLUMNS/LINE ARE IN
; [AX] AND THE PAGE IF APPLICABLE IS IN [BH]. THE STACK
; HAS DS,AX,BX,CX,DX PUSHED. [AL] HAS VIDEO MODE
;
; *****
028B BA CC      MOV CL,AH          ; WILL MAKE USE OF [CX] REGISTER TO
028D B5 19      MOV CH,25         ; CONTROL ROW & COLUMNS
028F E8 02E7 R  CALL CRLF         ; CARRIAGE RETURN LINE FEED ROUTINE
0292 51         PUSH CX          ; SAVE SCREEN BOUNDS
0293 B4 03      MOV AH,3          ; WILL NOW READ THE CURSOR.
0295 CD 10      INT 10H         ; AND PRESERVE THE POSITION
0297 59         POP CX          ; RECALL SCREEN BOUNDS
0298 52         PUSH DX         ; RECALL [BH]=VISUAL PAGE
0299 33 D2      XOR DX,DX        ; WILL SET CURSOR POSITION TO [0,0]
; *****
; THE LOOP FROM PRI10 TO THE INSTRUCTION PRIOR TO PRI20
; IS THE LOOP TO READ EACH CURSOR POSITION FROM THE SCREEN
; AND PRINT.
; *****
029B B4 02      MOV AH,2          ; TO INDICATE CURSOR SET REQUEST
029D CD 10      INT 10H         ; NEW CURSOR POSITION ESTABLISHED
029F B4 08      MOV AH,8          ; TO INDICATE READ CHARACTER
02A1 CD 10      INT 10H         ; CHARACTER NOW IN [AL]
02A3 0A C0     OR AL,AL        ; SEE IF VALID CHAR
02A5 75 02     JNZ PR115       ; JUMP IF VALID CHAR
02A7 B0 20     MOV AL,' '      ; MAKE A BLANK
02A9          PR115:
02AB 52         PUSH DX          ; SAVE CURSOR POSITION
02AC 33 D2     XOR DX,DX        ; INDICATE PRINTER 1
02AE 32 E4     XOR AH,AH        ; TO INDICATE PRINT CHAR IN [AL]
02B0 CD 17     INT 17H         ; PRINT THE CHARACTER
02B1 F6 C4 29  POP DX          ; RECALL CURSOR POSITION
02B4 75 21     TEST AH,29H     ; TEST FOR PRINTER ERROR
02B6 FE C2     JNZ ERR10      ; JUMP IF ERROR DETECTED
02B8 3A CA     CMP CL,DL       ; ADVANCE TO NEXT COLUMN
02BA 75 DF     JNZ PR110      ; SEE IF AT END OF LINE
02BC 32 D2     XOR DL,DL       ; IF NOT PROCEED
02BE BA E2     MOV AH,DL       ; BACK TO COLUMN 0
02C0 52         PUSH DX          ; [AH]=0
02C1 EB 02E7 R  CALL CRLF        ; SAVE NEW CURSOR POSITION
02C4 5A         POP DX          ; LINE FEED CARRIAGE RETURN
02C5 FE C6     INC DH          ; RECALL CURSOR POSITION
02C7 3A EE     CMP CH,DH       ; ADVANCE TO NEXT LINE
02C9 75 D0     JNZ PR120      ; IF FINISHED?
02CB 5A         POP DX          ; IF NOT CONTINUE
02CC B4 02     MOV AH,2        ; RECALL CURSOR POSITION
02CE CD 10     INT 10H         ; TO INDICATE CURSOR SET REQUEST
02D0 C6 06 0000 R 00 MOV STATUS_BYTE,0 ; CURSOR POSITION RESTORED
02D5 EB 0A     JMP SHORT EXIT  ; INDICATE FINISHED
02D7 5A         POP DX          ; EXIT THE ROUTINE
02DA B4 02     MOV AH,2        ; GET CURSOR POSITION
02DB CD 10     INT 10H         ; TO REQUEST CURSOR SET
02DC C6 06 0000 R FF MOV STATUS_BYTE,0FFH ; CURSOR POSITION RESTORED
; INDICATE ERROR
EXIT: POP DX          ; RESTORE ALL THE REGISTERS USED
     POP CX
     POP BX
     POP AX
     POP DS
     IRET
PRINT_SCREEN_1 ENDP
;----- CARRIAGE RETURN, LINE FEED SUBROUTINE
CRLF PROC NEAR
     XOR DX,DX          ; PRINTER 0
     XOR AH,AH         ; WILL NOW SEND INITIAL LF,CR TO PRINTER
     MOV AL,12QH       ; LF
     INT 17H          ; SEND THE LINE FEED
     XOR AH,AH         ; NOW FOR THE CR
     MOV AL,15QH       ; CR
     INT 17H          ; SEND THE CARRIAGE RETURN
     RET
CRLF ENDP
CODE ENDS
END

```



0000

```

TITLE 12/08/83 ORGS
.LIST
C INCLUDE SEGMENT_SRC PUBLIC
C CODE SEGMENT BYTE PUBLIC
C
ASSUME CS:CODE, DS:DATA

EXTRN K16:NEAR
EXTRN INT_287:NEAR
EXTRN DSKETTE_SETUP:NEAR
EXTRN DISK_SETUP:NEAR
EXTRN SEEK:NEAR
EXTRN RTC_INT:NEAR
EXTRN START_1:NEAR
EXTRN NMI_INT_1:NEAR
EXTRN BOOT_STRAP_1:NEAR
EXTRN KEYBOARD_IO_1:NEAR
EXTRN KB_INT_1:NEAR
EXTRN DISKETTE_IO_1:NEAR
EXTRN DISK_INT_1:NEAR
EXTRN PRINTER_IO_1:NEAR
EXTRN VIDEO_IO_1:NEAR
EXTRN MEMORY_SIZE_DETERMINE_1:NEAR
EXTRN EQUIPMENT_1:NEAR
EXTRN CASSETTE_IO_1:NEAR
EXTRN TIME_OF_DAY_1:NEAR
EXTRN TIMER_INT_1:NEAR
EXTRN D11:NEAR
EXTRN RS232_IO_1:NEAR
EXTRN DUMMY_RETURN_1:NEAR
EXTRN PRINT_SCREEN_1:NEAR
EXTRN C11:NEAR
EXTRN C30:NEAR
EXTRN TST4_B:NEAR
EXTRN TST4_C:NEAR
EXTRN TST4_D:NEAR
EXTRN E30B:NEAR
EXTRN E30C:NEAR
EXTRN RE_DIRECT:NEAR

PUBLIC BOOT_INVA
PUBLIC TUTOR
PUBLIC START
PUBLIC C1
PUBLIC C2
PUBLIC C8042A
PUBLIC OBF_42B
PUBLIC OBF_42A
PUBLIC C8042B
PUBLIC C8042C
PUBLIC E0
PUBLIC EO_A
PUBLIC EO_B
PUBLIC VIR_ERR
PUBLIC E1
PUBLIC F3A
PUBLIC D1
PUBLIC D2
PUBLIC D2A
PUBLIC F3D
PUBLIC F3D1
PUBLIC F1
PUBLIC F1_A
PUBLIC F1_B
PUBLIC F3
PUBLIC LOCK
PUBLIC CM1
PUBLIC CM2
PUBLIC CM3
PUBLIC CM4

PUBLIC CM4_A
PUBLIC CM4_B
PUBLIC CM4_C
PUBLIC CM4_D
PUBLIC F3B
PUBLIC F4
PUBLIC F4E
PUBLIC E1_A
PUBLIC E1_B
PUBLIC E1_C
PUBLIC ADERR
PUBLIC ADERR1
PUBLIC VECTOR_TABLE
PUBLIC SLAVE_VECTOR_TABLE
PUBLIC DISK_BASE
PUBLIC VIDEO_PARMS
PUBLIC M4
PUBLIC M5
PUBLIC M6
PUBLIC M7
PUBLIC CRT_CHAR_GEN
PUBLIC PRINT_SCREEN
PUBLIC A1
PUBLIC K6
PUBLIC K6L
PUBLIC K7
PUBLIC K8
PUBLIC K9
PUBLIC K10
PUBLIC K11
PUBLIC K12
PUBLIC K13
PUBLIC K14
PUBLIC K15
PUBLIC RS232_IO
PUBLIC DUMMY_RETURN
PUBLIC NMI_INT
PUBLIC BOOT_STRAP
PUBLIC KEYBOARD_IO
PUBLIC KB_INT
PUBLIC DISKETTE_IO
PUBLIC DISK_INT
PUBLIC PRINTER_IO
PUBLIC VIDEO_IO
PUBLIC MEMORY_SIZE_DETERMINE
PUBLIC EQUIPMENT
PUBLIC CASSETTE_IO
PUBLIC TIME_OF_DAY
PUBLIC TIMER_INT
PUBLIC HRD
PUBLIC FLOPPY
PUBLIC SEKS_1
PUBLIC F1780
PUBLIC F1781
PUBLIC F1782

```

PUBLIC F1790
PUBLIC F1791
PUBLIC FD_TBL

: THIS MODULE HAS BEEN ADDED TO FACILITATE THE EXPANSION OF THIS PROGRAM. :
: IT ALLOWS FOR THE FIXED ORG STATEMENT ENTRY POINTS THAT HAVE TO REMAIN :
: AT THE SAME ADDRESSES. ADDED ON 9/16/82 :

: COPYRIGHT NOTICE

0000 36 31 38 31 30 32
38 20 43 4F 50 52
2E 20 49 42 4D 20
31 39 38 34

; ORG OE000H
DB '6181028 CPR. IBM 1984'

005B
005B
005B E9 0000 E

; ORG OE05BH
ORG 0005BH
RESET LABEL FAR
START: JMP START_1

; ++++++

005E 0000 E
0060 0000 E
0062 0000 E
0064 0000 E
0066 0000 E
0068 0000 E
006A 0000 E

: TEMPORARY STACK FOR POST

C1 DW C11
C2 DW C30
C8042A DW TST4_B
0BF 42A DW TST4_C
C8042B DW TST4_D
C8042C DW E30B
0BF 42B DW E30C

006C 20 31 30 31 2D 53
79 73 74 65 6D 20
42 6F 61 72 64 20
45 72 72 6F 72 0D
0A

E0 DB '101-System Board Error',13,10 ; INTERRUPT FAILURE

0085 20 31 30 32 2D 53
79 73 74 65 6D 20
42 6F 61 72 64 20
45 72 72 6F 72 0D
0A

E0_A DB '102-System Board Error',13,10 ; TIMER FAILURE

009E 20 31 30 33 2D 53
79 73 74 65 6D 20
42 6F 61 72 64 20
45 72 72 6F 72 0D
0A

E0_B DB '103-System Board Error',13,10 ; TIMER INTERRUPT FAILURE

00B7 20 31 30 34 2D 53
79 73 74 65 6D 20
42 6F 61 72 64 20
45 72 72 6F 72 0D
0A

VIR_ERR DB '104-System Board Error',13,10 ; PROTECTED MODE FAILURE

00D0 20 31 30 35 2D 53
79 73 74 65 6D 20
42 6F 61 72 64 20
45 72 72 6F 72 0D
0A

CM4 DB '105-System Board Error',13,10 ; LAST 8042 COMMAND NOT ACCEPTED

00E9 20 32 30 31 2D 4D
65 6D 6F 72 79 20
45 72 72 6F 72 0D
0A

E1 DB '201-Memory Error',13,10

00FC 20 34 30 31 2D 43
52 54 20 45 72 72
6F 72 0D 0A

E1_B DB '401-CRT Error',13,10

010C 20 35 30 31 2D 43
52 54 20 45 72 72
6F 72 0D 0A

E1_C DB '501-CRT Error',13,10

011C 20 32 30 32 2D 4D
65 6D 6F 72 79 20
41 64 64 72 65 73
73 20 45 72 72 6F
72 0D 0A

ADERR1 DB '202-Memory Address Error',13,10 ; LINE ERROR 00->15

0137 20 32 30 33 2D 4D
65 6D 6F 72 79 20
41 64 64 72 65 73
73 20 45 72 72 6F
72 0D 0A

ADERR DB '203-Memory Address Error',13,10 ; LINE ERROR 16->23

0152 52 4F 4D 20 45 72
72 6F 72 0D 0A

F3A DB 'ROM Error',13,10 ; ROM CHECKSUM

015D 20 4B 42 20 4F 4B
0D

F3B DB 'KB Ok',13 ; KB FOR MEMORY SIZE

0164 50 41 52 49 54 59
20 43 48 45 43 4B
20 32 0D 0A

D1 DB 'PARITY CHECK 2',13,10

0174 50 41 52 49 54 59
20 43 48 45 43 4B
20 31 0D 0A

D2 DB 'PARITY CHECK 1',13,10

0184 3F 3F 3F 3F 0D
0A

D2A DB '?????',13,10

018B 20 28 52 45 53 55
4D 45 20 3D 20 22
46 31 22 2D 4B 45
59 29 0D 0A

F3D DB ' (RESUME = "F1" KEY)',13,10

01A1 20 20 20 20 2D 55
6E 6C 6F 63 6B 20
53 79 73 74 65 6D
20 55 6E 69 74 20
4B 65 79 6C 6F 63
6B 0D 0A

F3D1 DB ' -Unlock System Unit Keylock',13,10

01C2 20 33 30 31 2D 4B
65 79 62 6F 61 72
6A 20 45 72 72 6F
72 0D 0A

F1 DB '301-Keyboard Error',13,10 ; KEYBOARD ERROR

01D7 20 33 30 32 2D 53
79 73 74 65 6D 20
55 6E 69 74 20 4B
65 79 6C 6F 63 6B
20 69 73 20 4C 6F
63 6B 65 64 0D 0A
20 33 30 33 2D 4B
65 79 62 6F 61 72
6A 20 4F 72 20 53
79 73 74 65 6D 20
55 6E 69 74 20 45
72 72 6F 72 0D 0A

LOCK DB '302-System Unit Keylock is Locked',13,10 ; KEYBOARD LOCK ON

01FB

F1_A DB '303-Keyboard Or System Unit Error',13,10

```

021F 20 36 30 31 2D 44 F3 DB ' 601-Diskette Error',13,10 ; DISKETTE ERROR
69 73 6B 65 74 74
65 20 45 72 72 6F
72 0D 0A

0234 20 31 36 31 2D 53 CM1 DB ' 161-System Options Not Set-(Run SETUP)',13,10 ; DEAD BATTERY
79 73 74 65 6D 20
4F 70 74 69 6F 6E
73 20 4E 6F 74 20
53 65 74 2D 28 52
75 6E 20 53 45 54
55 50 29 0D 0A

025D 20 31 36 32 2D 53 CM2 DB ' 162-System Options Not Set-(Run SETUP)',13,10
79 73 74 65 6D 20
4F 70 74 69 6F 6E
73 20 4E 6F 74 20
53 65 74 2D 28 52
75 6E 20 53 45 54
55 50 29 0D 0A

0286 20 31 36 33 2D 54 CM3 DB ' 163-Time & Date Not Set-(Run SETUP)',13,10 ;CMOS CHECKSUM ERROR
69 6D 65 20 26 20
44 61 74 65 20 4E
6F 74 20 53 65 74
2D 28 52 75 6E 20
53 45 54 55 50 29
0D 0A

;-----
; PRINTER TABLE
;-----
02AC 03BC F4 LABEL WORD
02AE 0378 DW 3BCH
02B0 0278 DW 378H
02B2 F4E LABEL WORD

;----- NMI ENTRY
;
02C3 ORG 0E2C3H
= 02C3 ORG 002C3H
EQU $

02C3 E9 0000 E JMP NMI_INT_1

02C6 20 31 30 36 2D 53 CM4_A DB ' 106-System Board Error',13,10 ; CONVERTING LOGIC TEST
79 73 74 65 6D 20
42 6F 61 72 64 20
45 72 72 6F 72 0D
0A

02DF 20 31 30 37 2D 53 CM4_B DB ' 107-System Board Error',13,10 ; HOT NMI TEST
79 73 74 65 6D 20
42 6F 61 72 64 20
45 72 72 6F 72 0D
0A

02F8 20 31 30 38 2D 53 CM4_C DB ' 108-System Board Error',13,10 ; TIMER BUS TEST
79 73 74 65 6D 20
42 6F 61 72 64 20
45 72 72 6F 72 0D
0A

0311 20 31 30 39 2D 53 CM4_D DB ' 109-System Board Error',13,10 ; LOW MEG CHIP SELECT TEST
79 73 74 65 6D 20
42 6F 61 72 64 20
45 72 72 6F 72 0D
0A

032A 20 31 36 34 2D 4D E1_A DB ' 164-Memory Size Error-(Run SETUP)',13,10 ;----- MEMORY SIZE ERROR
65 6D 6F 72 79 20
53 69 74 65 20 45
72 72 6F 72 2D 28
52 75 6E 20 53 45
54 55 50 29 0D 0A

;----- KEYBOARD/SYSTEM ERROR
034E 20 33 30 34 2D 4B F1_B DB ' 304-Keyboard Or System Unit Error',13,10 ; CMOS DOES NOT MATCH SYSTEM
65 79 62 6F 61 72
64 20 4F 72 2D 53
79 73 74 65 6D 20
55 6E 69 74 2D 45
72 72 6F 72 0D 0A

; KEYBOARD CLOCK LINE HIGH

0372 20 36 30 32 2D 44 BOOT_INVA DB ' 602-Diskette Boot Record Error',13,10 ;----- DISKETTE BOOT RECORD IS NOT VALID
69 73 6B 65 74 74
65 20 42 6F 6F 74
20 52 65 63 6F 72
64 20 45 72 72 6F
72 0D 0A

0393 31 37 38 30 2D 44 F1780 DB ' 1780-Disk 0 Failure',0DH,0AH ;----- HARD FILE ERROR MSG
69 73 6B 20 30 20
46 61 69 6C 75 72
65 0D 0A

03A8 31 37 38 31 2D 44 F1781 DB ' 1781-Disk 1 Failure',0DH,0AH
69 73 6B 20 31 20
46 61 69 6C 75 72
65 0D 0A

03BD 31 37 38 32 2D 44 F1782 DB ' 1782-Disk Controller Failure',0DH,0AH
69 73 6B 20 43 6F
6E 74 72 6F 6C 6C
65 72 20 46 61 69
6C 75 72 6F 6A 0A

03DB 31 37 39 30 2D 44 F1790 DB ' 1790-Disk 0 Error',0DH,0AH
69 73 6B 20 30 20
45 72 72 6F 72 0D
0A

03EE 31 37 39 31 2D 44 F1791 DB ' 1791-Disk 1 Error',0DH,0AH
69 73 6B 20 31 20
45 72 72 6F 72 0D
0A

;-----
; INITIALIZE DRIVE CHARACTERISTICS
;
; FIXED DISK PARAMETER TABLE
;
; - THE TABLE IS COMPOSED OF A BLOCK DEFINED AS:
;
; +0 (1 WORD) - MAXIMUM NUMBER OF CYLINDERS
; +2 (1 BYTE) - MAXIMUM NUMBER OF HEADS
; +3 (1 WORD) - NOT USED/SEE PC-XT
; +5 (1 WORD) - STARTING WRITE PRECOMPENSATION CYL
; +7 (1 BYTE) - NOT USED/SEE PC-XT
; +8 (1 BYTE) - CONTROL BYTE
;
; BIT 7 DISABLE RETRIES -OR-
; BIT 6 DISABLE RETRIES
;

```

```

; BIT 3 MORE THAN 8 HEADS ;
; +9 (3 BYTES) - NOT USED/SEE PC-XT ;
; +12 (1 WORD) - LANDING ZONE ;
; +14 (1 BYTE) - NUMBER OF SECTORS/TRACK ;
; +15 (1 BYTE) - RESERVED FOR FUTURE USE ;
;
; - TO DYNAMICALLY DEFINE A SET OF PARAMETERS ;
; - BUILD A TABLE FOR UP TO 15 TYPES AND PLACE ;
; THE CORRESPONDING VECTOR INTO INTERRUPT 41 ;
; FOR DRIVE 0 AND INTERRUPT 46 FOR DRIVE 1. ;
;
;-----

```

0401

FD_TBL:

```

;----- DRIVE TYPE 01
0401 0132 DW 0306D ; CYLINDERS
0403 04 DB 04D ; HEADS
0404 0000 DW 0 ;
0406 0080 DW 0128D ; WRITE PRE-COMPENSATION CYL
0408 00 DB 0 ;
0409 00 DB 0 ; CONTROL BYTE
040A 00 00 00 DB 0,0,0 ;
040D 0131 DW 0305D ; LANDING ZONE
040F 11 DB 17D ; SECTORS/TRACK
0410 00 DB 0 ;

;----- DRIVE TYPE 02
0411 0267 DW 0615D ; CYLINDERS
0413 04 DB 04D ; HEADS
0414 0000 DW 0 ;
0416 012C DW 0300D ; WRITE PRE-COMPENSATION CYL
0418 00 DB 0 ;
0419 00 DB 0 ; CONTROL BYTE
041A 00 00 00 DB 0,0,0 ;
041D 0267 DW 0615D ; LANDING ZONE
041F 11 DB 17D ; SECTORS/TRACK
0420 00 DB 0 ;

;----- DRIVE TYPE 03
0421 0267 DW 0615D ; CYLINDERS
0423 06 DB 06D ; HEADS
0424 0000 DW 0 ;
0426 012C DW 0300D ; WRITE PRE-COMPENSATION CYL
0428 00 DB 0 ;
0429 00 DB 0 ; CONTROL BYTE
042A 00 00 00 DB 0,0,0 ;
042D 0267 DW 0615D ; LANDING ZONE
042F 11 DB 17D ; SECTORS/TRACK
0430 00 DB 0 ;

;----- DRIVE TYPE 04
0431 03AC 0428 DW 0940D ; CYLINDERS
0433 08 DB 08D ; HEADS
0434 0000 DW 0 ;
0436 0200 DW 0512D ; WRITE PRE-COMPENSATION CYL
0438 00 DB 0 ;
0439 00 DB 0 ; CONTROL BYTE
043A 00 00 00 DB 0,0,0 ;
043D 03AC DW 0940D ; LANDING ZONE
043F 11 DB 17D ; SECTORS/TRACK
0440 00 DB 0 ;

;----- DRIVE TYPE 05
0441 03AC DW 0940D ; CYLINDERS
0443 06 DB 06D ; HEADS
0444 0000 DW 0 ;
0446 0200 DW 0512D ; WRITE PRE-COMPENSATION CYL
0448 00 DB 0 ;
0449 00 DB 0 ; CONTROL BYTE
044A 00 00 00 DB 0,0,0 ;
044D 03AC DW 0940D ; LANDING ZONE
044F 11 DB 17D ; SECTORS/TRACK
0450 00 DB 0 ;

;----- DRIVE TYPE 06
0451 0267 0259 DW 0615D ; CYLINDERS
0453 04 5 DB 04D ; HEADS
0454 0000 DW 0 ;
0456 FFFF DW 0FFFFH ; WRITE PRE-COMPENSATION CYL
0458 00 DB 0 ;
0459 00 DB 0 ; CONTROL BYTE
045A 00 00 00 DB 0,0,0 ;
045D 0267 DW 0615D ; LANDING ZONE
045F 11 DB 17D ; SECTORS/TRACK
0460 00 DB 0 ;

;----- DRIVE TYPE 07
0461 01CE DW 0462D ; CYLINDERS
0463 08 DB 08D ; HEADS
0464 0000 DW 0 ;
0466 0100 DW 0256D ; WRITE PRE-COMPENSATION CYL
0468 00 DB 0 ;
0469 00 DB 0 ; CONTROL BYTE
046A 00 00 00 DB 0,0,0 ;
046D 01FF DW 0511D ; LANDING ZONE
046F 11 DB 17D ; SECTORS/TRACK
0470 00 DB 0 ;

;----- DRIVE TYPE 08
0471 02DD 039D DW 0733D ; CYLINDERS
0473 05 5 DB 05D ; HEADS
0474 0000 DW 0 ;
0476 FFFF DW 0FFFFH ; NO WRITE PRE-COMPENSATION
0478 00 DB 0 ;
0479 00 DB 0 ; CONTROL BYTE
047A 00 00 00 DB 0,0,0 ;
047D 02DD DW 0733D ; LANDING ZONE
047F 11 DB 17D ; SECTORS/TRACK
0480 00 DB 0 ;

;----- DRIVE TYPE 09
0481 0384 DW 0900D ; CYLINDERS
0483 0F DB 15D ; HEADS
0484 0000 DW 0 ;
0486 FFFF DW 0FFFFH ; NO WRITE PRE-COMPENSATION
0488 00 DB 0 ;

```

```

0489 08 DB 008H ; CONTROL BYTE
048A 00 00 00 DB 0,0,0
048D 0385 DW 0901D ; LANDING ZONE
048F 11 DB 17D ; SECTORS/TRACK
0490 00 DB 0

;----- DRIVE TYPE 10

0491 0334 DW 0820D ; CYLINDERS
0493 03 DB 03D ; HEADS
0494 0000 DW 0 ;
0496 FFFF DB 0FFFFH ; NO WRITE PRE-COMPENSATION
0498 00 DB 0 ;
0499 00 DB 0 ; CONTROL BYTE
049A 00 00 00 DB 0,0,0
049D 0334 DW 0820D ; LANDING ZONE
049F 11 DB 17D ; SECTORS/TRACK
04A0 00 DB 0

;----- DRIVE TYPE 11

04A1 0357 DW 0855D ; CYLINDERS
04A3 05 DB 05D ; HEADS
04A4 0000 DW 0 ;
04A6 FFFF DB 0FFFFH ; NO WRITE PRE-COMPENSATION
04A8 00 DW 0 ;
04A9 00 DB 0 ; CONTROL BYTE
04AA 00 00 00 DB 0,0,0
04AD 0357 DW 0855D ; LANDING ZONE
04AF 11 DB 17D ; SECTORS/TRACK
04B0 00 DB 0

;----- DRIVE TYPE 12

04B1 0357 DW 0855D ; CYLINDERS
04B3 07 DB 07D ; HEADS
04B4 0000 DW 0 ;
04B6 FFFF DW 0FFFFH ; NO WRITE PRE-COMPENSATION
04B8 00 DB 0 ;
04B9 00 DB 0 ; CONTROL BYTE
04BA 00 00 00 DB 0,0,0
04BD 0357 DW 0855D ; LANDING ZONE
04BF 11 DB 17D ; SECTORS/TRACK
04C0 00 DB 0

;----- DRIVE TYPE 13

04C1 0132 DW 0306D ; CYLINDERS
04C3 08 DB 08D ; HEADS
04C4 0000 DW 0 ;
04C6 0080 DW 0128D ; WRITE PRE-COMPENSATION CYL
04C8 00 DB 0 ;
04C9 00 DB 0 ; CONTROL BYTE
04CA 00 00 00 DB 0,0,0
04CD 013F DW 0319D ; LANDING ZONE
04CF 11 DB 17D ; SECTORS/TRACK
04D0 00 DB 0

;----- DRIVE TYPE 14

04D1 02DD DW 0733D ; CYLINDERS
04D3 07 DB 07D ; HEADS
04D4 0000 DW 0 ;
04D6 FFFF DW 0FFFFH ; WRITE PRE-COMPENSATION CYL
04D8 00 DW 0 ;
04D9 00 DB 0 ; CONTROL BYTE
04DA 00 00 00 DB 0,0,0
04DD 02DD DW 0733D ; LANDING ZONE
04DF 11 DB 17D ; SECTORS/TRACK
04E0 00 DB 0

;----- DRIVE TYPE 15 RESERVED ***** DO NOT USE *****

04E1 0000 DW 0000D ; CYLINDERS
04E3 00 DB 00D ; HEADS
04E4 0000 DW 0 ;
04E6 0000 DW 0000D ; WRITE PRE-COMPENSATION CYL
04E8 00 DB 0 ;
04E9 00 DB 0 ; CONTROL BYTE
04EA 00 00 00 DB 0,0,0
04ED 0000 DW 0000D ; LANDING ZONE
04EF 00 DB 00D ; SECTORS/TRACK
04F0 00 DB 0

;----- BOOT LOADER INTERRUPT

; ORG 0E6F2H
; ORG 006F2H
06F2 = 06F2 BOOT_STRAP EQU S
06F2 E9 0000 E JMP BOOT_STRAP_1

;-----BAUD RATE INIT

; ORG 0E729H
; ORG 00729H
A1 LABEL WORD

0729 0417 DW 1047 ; 110 BAUD
072B 0300 DW 768 ; 150
072D 0180 DW 384 ; 300
072F 00C0 DW 192 ; 600
0731 0050 DW 96 ; 1200
0733 0030 DW 48 ; 2400
0735 0018 DW 24 ; 4800
0737 000C DW 12 ; 9600

;----- RS232

; ORG 0E739H
; ORG 00739H
RS232_10 EQU S
0739 = 0739 JMP RS232_10_1
0739 E9 0000 E

;----- KEYBOARD

; ORG 0E82EH
; ORG 0082EH
KEYBOARD_10 EQU S
082E = 082E JMP KEYBOARD_10_1
082E E9 0000 E

; ORG 0E87EH
; ORG 0087EH

;----- TABLE OF SHIFT KEYS AND MASK VALUES (EARLY PC)

```

```

087E
087E 52
087F 3A 45 46 38 1D
0884 2A 36
= 0008

```

```

0886
0886 80
0887 40 20 10 08 04
088C 02 01

```

```

088E 1B FF 00 FF FF FF
1E FF
0896 FF FF FF 1F FF 7F
FF 11
089E 17 05 12 14 19 15
09 0F
08A6 10 1B 1D 0A FF 01
13
08AD 04 06 07 08 0A 0B
0C FF FF
08B6 FF FF 1C 1A 18 03
16 02
08BE 0E 0D FF FF FF FF
FF FF
08C6 20 FF

```

```

08C8
08C8 5E 5F 60 61 62 63
64 65
08D0 66 67 FF FF 77 FF
84 FF
08D8 73 FF 74 FF 75 FF
76 FF
08E0 FF

```

```

08E1
08E1 1B 31 32 33 34 35
36 37 38 39 30 2D
3D 08 09

```

```

08F0 71 77 65 72 74 79
75 69 6F 70 5B 5D
0D FF 61 73 64 66
67 68 6A 6B 6C 3B
27

```

```

0909 60 FF 5C 7A 78 63
76 62 6E 6D 2C 2E
2F FF 2A FF 20
091A FF

```

```

091B
091B 1B 21 40 23 24 25
5E 26 2A 28 29 5F
2B 08 00

```

```

092A 51 57 45 52 54 59
55 49 4F 50 7B 7D
0D FF 41 53 44 46
47 48 4A 4B 4C 3A
22

```

```

U943 7E FF 7C 5A 58 43
56 42 4E 4D 3C 3E
3F FF 00 FF 20 FF

```

```

0955
0955 54 55 56 57 58 59
5A
095C 5B 5C 5D

```

```

095F
095F 68 69 6A 6B 6C
0964 6D 6E 6F 70 71

```

```

0969
0969 37 38 39 2D 34 35
36 2B 31 32 33 30
2E

```

```

0976
0976 47 48 49 FF 4B FF
4D
097D FF 4F 50 51 52 53

```

```

0987
= 0987
0987 E9 0000 E

```

```

0C59
= 0C59
0C59 E9 0000 E

```

```

0F57
= 0F57
0F57 E9 0000 E

```

```

0FC7

```

```

0FC7 DF
0FC8 02

```

```

K6 LABEL BYTE
DB INS_KEY ; INSERT_KEY
DB CAPS_KEY,NUM_KEY,SCROLL_KEY,ALT_KEY,CTL_KEY
DB LEFT_KEY,RIGHT_KEY
K6L EQU $-K6

```

```
;------ SHIFT_MASK_TABLE
```

```

K7 LABEL BYTE
DB INS_SHIFT ; INSERT MODE_SHIFT
DB CAPS_SHIFT,NUM_SHIFT,SCROLL_SHIFT,ALT_SHIFT,CTL_SHIFT
DB LEFT_SHIFT,RIGHT_SHIFT

```

```
;------ SCAN CODE TABLES
```

```

K8 DB 27,-1,0,-1,-1,-1,30,-1
DB -1,-1,-1,31,-1,127,-1,17
DB 23,5,18,20,25,21,9,15
DB 16,27,29,10,-1,1,19
DB 4,6,7,8,10,11,12,-1,-1
DB -1,-1,28,26,24,3,22,2
DB 14,13,-1,-1,-1,-1,-1,-1
DB ' ',-1

```

```
;------ CTL TABLE SCAN
```

```

K9 LABEL BYTE
DB 94,95,96,97,98,99,100,101
DB 102,103,-1,-1,119,-1,132,-1
DB 115,-1,116,-1,117,-1,118,-1
DB -1

```

```
;------ LC TABLE
```

```

K10 LABEL BYTE
DB 01BH,'1234567890='',08H,09H
DB 'qwertyuiop[]',0DH,-1,'asdfghjkl;',027H
DB 60H,-1,5CH,'zxcvbnm,./',-1,'*','-1',' '
DB -1

```

```
;------ UC TABLE
```

```

K11 LABEL BYTE
DB 27,'!@#$%',37,05EH,'&*()_+',08H,0
DB 'QWERTYUIOP[]',0DH,-1,'ASDFGHJKL:'''
DB 07EH,-1,'|ZXCVBNM<?>',-1,0,-1,' ',-1

```

```
;------ UC TABLE SCAN
```

```

K12 LABEL BYTE
DB 84,85,86,87,88,89,90
DB 91,92,93

```

```
;------ ALT TABLE SCAN
```

```

K13 LABEL BYTE
DB 104,105,106,107,108
DB 109,110,111,112,113

```

```
;------ NUM STATE TABLE
```

```

K14 LABEL BYTE
DB '789-456+1230.'

```

```
;------ BASE CASE TABLE
```

```

K15 LABEL BYTE
DB 71,72,73,-1,75,-1,77
DB -1,79,80,81,82,83

```

```
;------ KEYBOARD INTERRUPT
```

```

; ORG 0E987H
; ORG 00987H
KB_INT EQU $
JMP KB_INT_1

```

```
;------ DISKETTE I/O
```

```

; ORG 0EC59H
; ORG 00C59H
DISKETTE_IO EQU $
JMP DISKETTE_IO_1

```

```
;------ DISKETTE INTERRUPT
```

```

; ORG 0EF57H
; ORG 00F57H
DISK_INT EQU $
JMP DISK_INT_1

```

```
;------ DISKETTE PARMS
```

```

; ORG 0EFC7H
; ORG 00FC7H

```

```

; DISK_BASE
; THIS IS THE SET OF PARAMETERS REQUIRED FOR
; DISKETTE OPERATION. THEY ARE POINTED AT BY THE
; DATA VARIABLE DISK_POINTER. TO MODIFY THE PARAMETERS,
; BUILD ANOTHER PARAMETER BLOCK AND POINT AT IT

```

```

DISK_BASE LABEL BYTE
DISK_BASE LABEL BYTE
0FC7 DF ; SRT=D, HD UNLOAD=0F - 1ST SPECIFY BYTE
0FC8 02 ; HD LOAD=1, MODE=DMA - 2ND SPECIFY BYTE

```



```

OFC9 25          DB      MOTOR_WAIT      ; WAIT AFTER OPN TIL MOTOR OFF
OFC A 02          DB      2                ; 512 BYTES/SECTOR
OFCB 0F          DB      15               ; EOT ( LAST SECTOR ON TRACK)
OFC C 1B          DB      01BH            ; GAP LENGTH
OFCD FF          DB      0FFH            ; DTL
OFCE 54          DB      054H            ; GAP LENGTH FOR FORMAT
OFC F F6          DB      0F6H            ; FILL BYTE FOR FORMAT
OFD0 0F          DB      15               ; HEAD SETTLE TIME (MILLISECONDS)
OFD1 08          DB      8                ; MOTOR START TIME (1/8 SECONDS)

```

```

;----- PRINTER IO
;
;          ORG      0EFD2H
OFD2          ORG      0EFD2H
= 0FD2        EQU      $
OFD2 E9 0000 E JMP      PRINTER_IO_1

```

```

;----- VIDEO IO
;----- ADDED FOR POSSIBLE COMPATABILITY ENTRY POINTS

```

```

;ORG      0F045H
;ORG      01045H
1045        ASSUME  CS:CODE,DS:DATA,ES:VIDEO_RAM

```

```

EXTRN SET_MODE:NEAR
EXTRN SET_CTYPE:NEAR
EXTRN SET_CPOS:NEAR
EXTRN READ_CURSOR:NEAR
EXTRN READ_LPEN:NEAR
EXTRN ACT_DISP_PAGE:NEAR
EXTRN SCROLL_UP:NEAR
EXTRN SCROLL_DOWN:NEAR
EXTRN READ_AC_CURRENT:NEAR
EXTRN WRITE_AC_CURRENT:NEAR
EXTRN WRITE_C_CURRENT:NEAR
EXTRN SET_COLOR:NEAR
EXTRN WRITE_DOT:NEAR
EXTRN READ_DOT:NEAR
EXTRN WRITE_TTY:NEAR
EXTRN VIDEO_STATE:NEAR

```

```

1045        M1      LABEL WORD      ; TABLE OF ROUTINES WITHIN VIDEO I/O

```

```

1045 0000 E    DW      OFFSET SET_MODE
1047 0000 E    DW      OFFSET SET_CTYPE
1049 0000 E    DW      OFFSET SET_CPOS
104B 0000 E    DW      OFFSET READ_CURSOR
104D 0000 E    DW      OFFSET READ_LPEN
104F 0000 E    DW      OFFSET ACT_DISP_PAGE
1051 0000 E    DW      OFFSET SCROLL_UP
1053 0000 E    DW      OFFSET SCROLL_DOWN
1055 0000 E    DW      OFFSET READ_AC_CURRENT
1057 0000 E    DW      OFFSET WRITE_AC_CURRENT
1059 0000 E    DW      OFFSET WRITE_C_CURRENT
105B 0000 E    DW      OFFSET SET_COLOR
105D 0000 E    DW      OFFSET WRITE_DOT
105F 0000 E    DW      OFFSET READ_DOT
1061 0000 E    DW      OFFSET WRITE_TTY
1063 0000 E    DW      OFFSET VIDEO_STATE
= 0020

```

```

M1L EQU      $-M1
;          ORG      0F065H
1065        ORG      0F065H
= 1065      EQU      $
1065 E9 0000 E JMP      VIDEO_IO_1

```

```

;----- VIDEO PARMS

```

```

10A4        ;          ORG      0F0A4H
10A4        ;          ORG      010A4H
VIDEO_PARMS LABEL BYTE

```

```

;----- INIT_TABLE

```

```

10A4 38 28 2D 0A 1F 06  DB      38H,28H,20H,0AH,1FH,6,19H      ; SET UP FOR 40X25
19
10AB 1C 02 07 06 07    DB      1CH,2,7,6,7
10B0 00 00 00 00      DB      0,0,0,0
= 0010        EQU      S-VIDEO_PARMS
M4
10B4 71 50 5A 0A 1F 06  DB      71H,50H,5AH,0AH,1FH,6,19H      ; SET UP FOR 80X25
19
10BB 1C 02 07 06 07    DB      1CH,2,7,6,7
10C0 00 00 00 00      DB      0,0,0,0
10C4 38 28 2D 0A 7F 06  DB      38H,28H,20H,0AH,7FH,6,64H      ; SET UP FOR GRAPHICS
64
10CB 70 02 01 06 07    DB      70H,2,1,6,7
10D0 00 00 00 00      DB      0,0,0,0
10D4 61 50 52 0F 19 06  DB      61H,50H,52H,0FH,19H,6,19H      ; SET UP FOR 80X25 B&W CARD
19
10DB 19 02 0D 0B 0C    DB      19H,2,0DH,0BH,0CH
10E0 00 00 00 00      DB      0,0,0,0

```

```

M5 LABEL WORD      ; TABLE OF REGEN LENGTHS
DW      2048          ; 40X25
DW      4096          ; 80X25
DW      16384         ; GRAPHICS
DW      16384

```

```

;----- COLUMNS

```

```

10EC        M6      LABEL BYTE
10EC 28 28 50 50 28 28  DB      40,40,80,80,40,40,80,80
50 50

```

```

;----- C_REG_TAB

```

```

10F4        M7      LABEL BYTE      ; TABLE OF MODE SETS
10F4 2C 28 2D 29 2A 2E  DB      2CH,28H,20H,29H,2AH,2EH,29H ;
1E 29

```

```

;----- MEMORY SIZE

```

```

;          ORG      0F841H
1841        ORG      01841H
= 1841      EQU      $
1841 E9 0000 E JMP      MEMORY_SIZE_DETERMINE_1

```

```

;----- EQUIPMENT DETERMINE

```

```

184D
= 184d
184D E9 0000 E

```

```

;
ORC OF84DH
ORC 0184DH
EQUIPMENT EQU $
JMP EQUIPMENT_1
;----- CASSETTE (NO BIOS SUPPORT)
;
ORC OF859H
CASSETTE_10 EQU $
JMP CASSETTE_10_1

```

```

;-----
; CHARACTER GENERATOR GRAPHICS FOR 320X200 AND 640X200 GRAPHICS
;-----

```

```

1A6E
1A6E 00 00 00 00 00 00
1A76 7E 81 A5 81 B0 99
81 7E
1A7E 7E FF DB FF C3 E7
7E FF
1A86 6C FE FE FE 7C 38
10 00
1A8E 10 38 7C FE 7C 38
10 00
1A96 38 7C 38 FE FE 7C
38 7C
1A9E 10 38 7C FE 7C
38 7C
1AA6 00 00 18 3C 3C 18
00 00
1AAE FF FF E7 C3 C3 E7
FF FF
1AB6 00 3C 66 42 42 66
3C 00
1ABE FF C3 99 B0 8D 99
C3 FF
1AC6 0F 07 0F 7D CC CC
CC 78
1AC E 3C 66 66 66 3C 18
7E 18
1AD6 3F 33 3F 30 30 70
FO E0
1ADE 7F 63 7F 63 63 67
E6 C0
1AE6 99 5A 3C E7 E7 3C
5A 99
1AEE 80 E0 F8 FE F8 E0
80 00
1AF6 02 0E 3E FE 3E 0E
02 00
1AFE 18 3C 7E 18 18 7E
3C 18
1B06 66 66 66 66 66 00
66 00
1B0E 7F DB DB 78 18 1B
1B 00
1B16 3E 63 38 6C 6C 38
CC 78
1B1E 00 00 00 00 7E 7E
7E 00
1B26 18 3C 7E 18 7E 3C
18 FF
1B2E 18 3C 7E 18 18 18
18 00
1B36 18 18 18 18 7E 3C
18 00
1B3E 00 18 0C FE 0C 18
00 00
1B46 00 30 60 FE 60 30
00 00
1B4E 00 00 C0 C0 C0 FE
00 00
1B56 00 24 66 FF 66 24
00 00
1B5E 00 18 3C 7E FF FF
00 00
1B66 00 FF FE 7C 3C 18
00 00
1B6E 00 00 00 00 00 00
00 00
1B76 30 78 78 30 30 00
30 00
1B7E 6C 6C 6C 00 00 00
00 00
1B86 6C 6C FE 6C FE 6C
6C 00
1B8E 30 7C 0C 78 0C F8
30 00
1B96 00 C6 CC 18 30 66
C6 00
1B9E 38 6C 38 76 DC CC
76 00
1BA6 60 60 C0 00 00 00
00 00
1BAE 18 30 60 60 60 30
18 00
1BB6 60 30 18 18 18 30
60 00
1BBE 00 66 3C FF 3C 66
00 00
1BC6 00 30 30 FC 30 30
00 00
1BCE 00 00 00 00 00 30
30 60
1BD6 00 00 00 FC 00 00
00 00
1BDE 00 00 00 00 00 30
30 00
1BE6 06 0C 18 30 60 C0
80 00
1BEE 7C C6 CE DE F6 E6
7C 00
1BF6 30 70 30 30 30 30
FC 00
1BF E 78 CC 0C 38 60 CC
FC 00
1C06 78 CC 0C 38 0C CC
78 00

```

```

CRT_CHAR_GEN DB
000H,000H,000H,000H,000H,000H,000H,000H ; D_00
07EH,081H,0A5H,0B1H,0BDH,099H,081H,07EH ; D_01
07EH,0FFH,0DBH,0FFH,0C3H,0E7H,0FFH,07EH ; D_02
06CH,0FEH,0FEH,0FEH,07CH,038H,010H,000H ; D_03
010H,038H,07CH,0FEH,07CH,038H,010H,000H ; D_04
038H,07CH,038H,0FEH,0FEH,07CH,038H,07CH ; D_05
010H,010H,038H,07CH,0FEH,07CH,038H,07CH ; D_06
000H,000H,018H,03CH,03CH,018H,000H,000H ; D_07
0FFH,0FFH,0E7H,0C3H,0C3H,0E7H,0FFH,0FFH ; D_08
000H,03CH,066H,042H,042H,066H,03CH,000H ; D_09
0FFH,0C3H,099H,0BDH,0BDH,099H,0C3H,0FFH ; D_0A
00FH,007H,00FH,07DH,0CCH,0CCH,0CCH,078H ; D_0B
03CH,066H,066H,066H,03CH,018H,07EH,018H ; D_0C
03FH,033H,03FH,030H,030H,070H,0F0H,0E0H ; D_0D
07FH,063H,07FH,063H,063H,067H,0E6H,0C0H ; D_0E
099H,05AH,03CH,0E7H,0E7H,03CH,05AH,099H ; D_0F
080H,0E0H,0F8H,0FEH,0F8H,0E0H,080H,000H ; D_10
002H,00EH,03EH,0FEH,03EH,00EH,002H,000H ; D_11
018H,03CH,07EH,018H,018H,07EH,03CH,018H ; D_12
066H,066H,066H,066H,066H,000H,066H,000H ; D_13
07FH,0DBH,0DBH,078H,018H,018H,018H,000H ; D_14
03EH,063H,038H,06CH,06CH,038H,0CCH,078H ; D_15
000H,000H,000H,000H,07EH,07EH,07EH,000H ; D_16
018H,03CH,07EH,018H,07EH,03CH,018H,0FFH ; D_17
018H,03CH,07EH,018H,018H,018H,018H,000H ; D_18
018H,018H,018H,018H,07EH,03CH,018H,000H ; D_19
000H,018H,00CH,0FEH,00CH,018H,000H,000H ; D_1A
000H,030H,060H,0FEH,060H,030H,000H,000H ; D_1B
000H,000H,0C0H,0C0H,0C0H,0FEH,000H,000H ; D_1C
000H,024H,066H,0FFH,066H,024H,000H,000H ; D_1D
000H,018H,03CH,07EH,0FFH,0FFH,000H,000H ; D_1E
000H,0FFH,0FFH,07EH,03CH,018H,000H,000H ; D_1F
000H,000H,000H,000H,000H,000H,000H,000H ; SP D_20
030H,078H,078H,030H,030H,000H,030H,000H ; I D_21
06CH,06CH,06CH,000H,000H,000H,000H,000H ; " D_22
06CH,06CH,0FEH,06CH,0FEH,06CH,06CH,000H ; # D_23
030H,07CH,0C0H,078H,078H,00CH,0F8H,030H,000H ; $ D_24
000H,0C6H,0CCH,018H,030H,066H,0C6H,000H ; PER CENT D_25
038H,06CH,038H,076H,0DCH,0CCH,076H,000H ; & D_26
060H,060H,0C0H,000H,000H,000H,000H,000H ; ' D_27
018H,030H,060H,060H,060H,030H,018H,000H ; ( D_28
060H,030H,018H,018H,018H,030H,060H,000H ; ) D_29
000H,066H,03CH,0FFH,03CH,066H,000H,000H ; * D_2A
000H,030H,030H,0FCH,030H,030H,030H,000H ; + D_2B
000H,000H,000H,000H,000H,030H,030H,060H ; , D_2C
000H,000H,000H,0FCH,000H,000H,000H,000H ; - D_2D
000H,000H,000H,000H,000H,030H,030H,000H ; . D_2E
066H,00CH,018H,030H,060H,0C0H,080H,000H ; / D_2F
07CH,0C6H,0CEH,0DEH,0F6H,0E6H,07CH,000H ; 0 D_30
030H,070H,030H,030H,030H,030H,0FCH,000H ; 1 D_31
078H,0CCH,00CH,038H,060H,0CCH,0FCH,000H ; 2 D_32
078H,0CCH,00CH,038H,00CH,0CCH,078H,000H ; 3 D_33

```

1C0E	1C 3C 6C CC FE FC 0C	DB	01CH,03CH,06CH,0CCH,0FEH,00CH,01EH,000H ; 4 D_34
1C16	1E 00	DB	0FCH,0C0H,0F8H,00CH,00CH,0CCH,078H,000H ; 5 D_35
1C1E	FC 00 F8 0C 0C CC	DB	038H,060H,0C0H,0F8H,0CCH,0CCH,078H,000H ; 6 D_36
1C26	78 00	DB	0FCH,0CCH,00CH,018H,030H,030H,030H,000H ; 7 D_37
1C2E	FC CC 0C 18 3C 3C	DB	078H,0CCH,0CCH,078H,0CCH,0CCH,078H,000H ; 8 D_38
1C36	78 CC CC 7C 0C 18	DB	078H,0CCH,0CCH,07CH,00CH,018H,070H,000H ; 9 D_39
1C3E	70 00	DB	000H,030H,030H,000H,000H,030H,030H,000H ; : D_3A
1C46	00 30 30 00 00 30	DB	000H,030H,030H,000H,000H,030H,030H,060H ; > D_3B
1C4E	00 30 18 30 60 CO 60 30	DB	018H,030H,060H,0C0H,060H,030H,018H,000H ; < D_3C
1C56	18 00	DB	000H,000H,0FCH,000H,000H,0FCH,000H,000H ; = D_3D
1C5E	00 00 FC 00 00 FC	DB	060H,030H,018H,00CH,018H,030H,060H,000H ; > D_3E
1C66	60 30 18 0C 18 30	DB	078H,0CCH,00CH,018H,030H,000H,030H,000H ; ? D_3F
1C6E	78 CC 0C 18 30 00	DB	07CH,0C6H,0DEH,0DEH,0DEH,0C0H,078H,000H ; @ D_40
1C76	78 00	DB	030H,078H,0CCH,0CCH,0FCH,0CCH,0CCH,000H ; A D_41
1C7E	30 78 CC CC FC CC	DB	0FCH,066H,066H,07CH,066H,066H,0FCH,000H ; B D_42
1C86	FC 66 66 7C 66 66	DB	03CH,066H,0C0H,0C0H,0C0H,066H,03CH,000H ; C D_43
1C8E	FC 00	DB	0F8H,06CH,066H,066H,066H,06CH,0F8H,000H ; D D_44
1C96	F8 66 66 66 66 62	DB	0FEH,062H,068H,078H,068H,062H,0FEH,000H ; E D_45
1C9E	FE 62 68 78 68 60	DB	0FEH,062H,068H,078H,068H,060H,0F0H,000H ; F D_46
1CA6	FE 00	DB	03CH,066H,0C0H,0C0H,0CEH,066H,03EH,000H ; G D_47
1CAE	3C 66 0C CO CE 66	DB	0CCH,0CCH,0CCH,0FCH,0CCH,0CCH,0CCH,000H ; H D_48
1CB6	3E 00	DB	078H,030H,030H,030H,030H,030H,078H,000H ; I D_49
1CBE	78 30 30 30 30 30	DB	01EH,00CH,00CH,00CH,0CCH,0CCH,078H,000H ; J D_4A
1CBE	1E 0C 0C CC CC CC	DB	0E6H,066H,06CH,078H,06CH,066H,0E6H,000H ; K D_4B
1CC6	E6 66 6C 78 6C 66	DB	0F0H,060H,060H,060H,062H,066H,0FEH,000H ; L D_4C
1CCE	FC 66 6C 78 6C 60	DB	0C6H,0EEH,0FEH,0FEH,0D6H,0C6H,0C6H,000H ; M D_4D
1CD6	78 CC CC CC CC 78	DB	0C6H,0E6H,0F6H,0DEH,0CEH,0C6H,0C6H,000H ; N D_4E
1CDE	FC 00	DB	038H,06CH,0C6H,0C6H,0C6H,06CH,038H,000H ; O D_4F
1CE6	38 6C C6 C6 C6 6C	DB	0FCH,066H,066H,07CH,060H,060H,0F0H,000H ; P D_50
1CEE	FC 66 66 7C 6C 60	DB	078H,0CCH,0CCH,0CCH,0DCH,078H,01CH,000H ; Q D_51
1CF6	78 CC CC CC CC 78	DB	0FCH,066H,066H,07CH,06CH,066H,0E6H,000H ; R D_52
1CFE	FC 66 66 7C 6C 66	DB	078H,0CCH,0E0H,070H,01CH,0CCH,078H,000H ; S D_53
1D06	E6 00	DB	0FCH,0B4H,030H,030H,030H,030H,078H,000H ; T D_54
1D0E	FC B4 30 30 30 30	DB	0CCH,0CCH,0CCH,0CCH,0CCH,0CCH,0CCH,000H ; U D_55
1D16	78 00	DB	0CCH,0CCH,0CCH,0CCH,0CCH,078H,030H,000H ; V D_56
1D1E	CC CC CC CC CC 78	DB	0C6H,0C6H,0C6H,0D6H,0FEH,0EEH,0C6H,000H ; W D_57
1D26	CC CC CC 78 30 30	DB	0C6H,0C6H,06CH,038H,038H,06CH,06CH,000H ; X D_58
1D2E	C6 C6 6C 3E FE EC	DB	0CCH,0CCH,0CCH,078H,030H,030H,078H,000H ; Y D_59
1D36	C6 00	DB	0FEH,0C6H,08CH,018H,032H,066H,0FEH,000H ; Z D_5A
1D3E	C6 C6 8C 18 32 66	DB	078H,060H,060H,060H,060H,060H,078H,000H ; [D_5B
1D46	FE 00	DB	0C0H,060H,030H,018H,00CH,00CH,006H,002H,000H ; BACKSLASH D_5C
1D4E	78 60 60 60 60 60	DB	078H,018H,018H,018H,018H,018H,078H,000H ;] D_5D
1D56	78 00	DB	010H,038H,06CH,0C6H,000H,000H,000H,000H ; CIRCUMFLEX D_5E
1D5E	0C 60 30 18 0C 06	DB	000H,000H,000H,000H,000H,000H,000H,0FFH ; _ D_5F
1D66	02 00	DB	030H,030H,018H,000H,000H,000H,000H,000H ; ^ D_60
1D6E	78 18 18 18 18 18	DB	000H,000H,078H,00CH,07CH,0CCH,076H,000H ; LOWER CASE A D_61
1D76	00 00 78 0C 7C CC	DB	0E0H,060H,060H,07CH,066H,066H,0DCH,000H ; L.C. B D_62
1D7E	76 00	DB	000H,000H,078H,0CCH,0C0H,0CCH,078H,000H ; L.C. C D_63
1D86	EO 60 60 7C 66 66	DB	01CH,00CH,00CH,07CH,0CCH,0CCH,076H,000H ; L.C. D D_64
1D8E	DC 00	DB	000H,000H,078H,0CCH,0FCH,0C0H,078H,000H ; L.C. E D_65
1D96	00 78 CC CC CC	DB	038H,06CH,060H,0F0H,060H,060H,0F0H,000H ; L.C. F D_66
1D9E	78 00	DB	000H,000H,076H,0CCH,0CCH,07CH,00CH,0F8H ; L.C. G D_67
1DA6	00 00 76 CC CC 7C	DB	0E0H,060H,06CH,076H,066H,066H,0E6H,000H ; L.C. H D_68
1DAE	DC F8	DB	030H,000H,070H,030H,030H,030H,078H,000H ; L.C. I D_69
1DAE	EO 60 6C 76 66 66	DB	00CH,000H,00CH,00CH,00CH,0CCH,0CCH,078H ; L.C. J D_6A
1DB6	E6 00	DB	0E0H,060H,066H,06CH,078H,06CH,066H,000H ; L.C. K D_6B
1DBE	30 00 70 30 30 30	DB	070H,030H,030H,030H,030H,030H,078H,000H ; L.C. L D_6C
1DBE	78 00	DB	000H,000H,0CCH,0FEH,0FEH,0D6H,0C6H,000H ; L.C. M D_6D
1DBE	0C 0C 0C 0C CC	DB	000H,000H,0F8H,0CCH,0CCH,0CCH,0CCH,000H ; L.C. N D_6E
1DC6	CC 78	DB	000H,000H,078H,0CCH,0CCH,0CCH,078H,000H ; L.C. O D_6F
1DC6	EO 66 6C 78 6C	DB	000H,000H,0DCH,066H,066H,07CH,060H,0F0H ; L.C. P D_70
1DCE	E6 00	DB	
1DCE	70 30 30 30 30 30	DB	
1DD6	78 00	DB	
1DD6	00 00 CC FE FE D6	DB	
1DD6	C6 00	DB	
1DDE	00 00 F8 CC CC CC	DB	
1DE6	CC 00	DB	
1DE6	00 00 78 CC CC CC	DB	
1DE6	78 00	DB	
1DEE	00 00 DC 66 66 7C	DB	
1DEE	60 F0	DB	

```

1DF6 00 00 76 CC CC 7C DB 000H,000H,076H,0CCH,0CCH,07CH,00CH,01EH ; L.C. Q D_71
      0C 1E DB
1DFE 00 00 DC 76 66 60 DB 000H,000H,0DCH,076H,066H,060H,0F0H,000H ; L.C. R D_72
      FO 00 DB
1E06 00 00 7C 30 78 0C DB 000H,000H,07CH,0C0H,078H,00CH,0F8H,000H ; L.C. S D_73
      F8 00 DB
1E0E 10 30 7C 30 30 34 DB 010H,030H,07CH,030H,030H,034H,018H,000H ; L.C. T D_74
      18 00 DB
1E16 00 00 CC CC CC CC DB 000H,000H,0CCH,0CCH,0CCH,0CCH,076H,000H ; L.C. U D_75
      76 00 DB
1E1E 00 00 CC CC CC 78 DB 000H,000H,0CCH,0CCH,0CCH,078H,030H,000H ; L.C. V D_76
      30 00 DB
1E26 00 00 C6 D6 FE FE DB 000H,000H,0C6H,0D6H,0FEH,0FEH,06CH,000H ; L.C. W D_77
      6C 00 DB
1E2E 00 00 C6 6C 38 6C DB 000H,000H,0C6H,06CH,038H,06CH,0C6H,000H ; L.C. X D_78
      C6 00 DB
1E36 00 00 CC CC CC 7C DB 000H,000H,0CCH,0CCH,0CCH,07CH,00CH,0F8H ; L.C. Y D_79
      0C F8 DB
1E3E 00 00 FC 98 30 64 DB 000H,000H,0FCH,098H,030H,064H,0FCH,000H ; L.C. Z D_7A
      FC 00 DB
1E46 1C 30 30 E0 30 30 DB 01CH,030H,030H,0E0H,030H,030H,01CH,000H ; I D_7B
      1C 00 DB
1E4E 18 18 18 00 18 18 DB 018H,018H,018H,000H,018H,018H,018H,000H ; I D_7C
      18 00 DB
1E56 E0 30 1C 30 30 30 DB 0E0H,030H,030H,01CH,030H,030H,0E0H,000H ; I D_7D
      E0 00 DB
1E5E 76 DC 00 00 00 00 DB 076H,0DCH,000H,000H,000H,000H,000H,000H ; ° D_7E
      00 00 DB
1E66 00 10 38 6C C6 C6 DB 000H,010H,038H,06CH,0C6H,0C6H,0FEH,000H ; DELTA D_7F
      FE 00 DB

.LIST
;----- TIME OF DAY
; ORG OFE6EH
; ORG 01E6EH
TIME_OF_DAY EQU $
1E6E E9 0000 E JMP TIME_OF_DAY_1

;----- TIMER INTERRUPT
; ORG OFEA5H
; ORG 01EA5H
TIMER_INT EQU $
1EA5 E9 0000 E JMP TIMER_INT_1

;----- VECTOR TABLE
; ORG OFEF3H
; ORG 01EF3H
VECTOR_TABLE LABEL WORD
1EF3 1EA5 R DW OFFSET TIMER_INT ; VECTOR TABLE
1EF5 09B7 R DW OFFSET KB_INT ; INTERRUPT 8
1EF7 0000 E DW OFFSET D11 ; INTERRUPT 9
1EF9 0000 E DW OFFSET D11 ; INTERRUPT A (SLAVE INPUT)
1EFB 0000 E DW OFFSET D11 ; INTERRUPT B
1EFD 0000 E DW OFFSET D11 ; INTERRUPT C
1EFF 0F57 R DW OFFSET DISK_INT ; INTERRUPT D
1F01 0000 E DW OFFSET D11 ; INTERRUPT F

;----- SOFTWARE INTERRUPTS
1F03 1065 R DW OFFSET VIDEO_IO ; INT 10H
1F05 184D R DW OFFSET EQUIPMENT ; INT 11H
1F07 1841 R DW OFFSET MEMORY_SIZE_DETERMINE ; INT 12H
1F09 0C59 R DW OFFSET DISKETTE_IO ; INT 13H
1F0B 0739 R DW OFFSET RS232_IO ; INT 14H
1F0D 1959 R DW CASSETTE_IO ; INT 15H
1F0F 082E R DW OFFSET KEYBOARD_IO ; INT 16H
1F11 0FD2 R DW OFFSET PRINTER_IO ; INT 17H
1F13 0000 DW 000000H ; INT 18H
; DW OF600H ; MUST BE INSERTED INTO TABLE LATER
1F15 06F2 R DW OFFSET BOOT_STRAP ; INT 19H
1F17 1E6E R DW TIME_OF_DAY ; INT 1AH -- TIME OF DAY
1F19 1F53 R DW DUMMY_RETURN ; INT 1BH -- KEYBOARD BREAK ADDR
1F1B 1F53 R DW DUMMY_RETURN ; INT 1CH -- TIMER BREAK ADDR
1F1D 10A4 R DW VIDEO_PARMS ; INT 1DH -- VIDEO PARAMETERS
1F1F 0FC7 R DW OFFSET DISK_BASE ; INT 1EH -- DISK PARMS
1F21 0000 DW 0 ; INT 1FH -- POINTER TO VIDEO EXT

1F23 SLAVE_VECTOR_TABLE LABEL WORD ; (INTERRUPT 70 THRU 7F)
1F23 0000 E DW OFFSET RTC_INT ; INT 70 REAL TIME CLOCK INTERRUPT VECTOR
1F25 0000 E DW OFFSET RE_DIRECT ; INT 71 REDIRECT THIS TO INT A
1F27 0000 E DW OFFSET D11 ; INT 72
1F29 0000 E DW OFFSET D11 ; INT 73
1F2B 0000 E DW OFFSET D11 ; INT 74
1F2D 0000 E DW OFFSET INT_287 ; INT 75 MATH PROCESSOR INTERRUPT
1F2F 0000 E DW OFFSET D11 ; INT 76
1F31 0000 E DW OFFSET D11 ; INT 77

;----- DUMMY INTERRUPT HANDLER
; ORG OFF53H
; ORG 01F53H
1F53 = 1F53 DUMMY_RETURN EQU $
1F53 CF IRET ;

;----- PRINT SCREEN
; ORG OFF54H
; ORG 01F54H
1F54 = 1F54 PRINT_SCREEN EQU $
1F54 E9 0000 E JMP PRINT_SCREEN_1

.LIST ; TUTOR

```

POWER ON RESET VECTOR

```

1FF0
1FF0
1FF0
1FF1 EA
1FF1 005B R
1FF3 F000
1FF5 30 31 2F 31 30 2F
      38 34
1FFE
1FFE FC
1FFF

PUBLIC P_O_R
P_O_R POWER ON RESET
      LABEL FAR

ORG 0FFF0H
ORG 01FFF0H
DB 0EAH RESET ;HARD CODE JUMP
DW 0FF00H ;OFFSET
DW 0F000H ;SEGMENT
DB '01/10/84' ;RELEASE MARKER
ORG 01FFEH ;
DB 0FCH ;THIS PC'S ID
CODE
ENDS
END

```



SECTION 6. INSTRUCTION SET

Contents

Instruction Sets	6-3
80286 Microprocessor Instruction Set	6-3
Data Transfer	6-3
Arithmetic	6-6
Logic	6-10
String Manipulation	6-12
Control Transfer	6-13
Processor Control	6-19
Protection Control	6-21
80287 Coprocessor Instruction Set	6-24
Data Transfer	6-24
Comparison	6-25
Constants	6-26
Arithmetic	6-27
Transcendental	6-29
Processor Control	6-29

Notes:



Instruction Set

80286 Microprocessor Instruction Set

The following is an instruction set summary for the Intel 80286 microprocessor.

Data Transfer

MOV = move

Register to Register Memory

1000100w	mod reg r/w
----------	-------------

Register/Memory to Register

1000101w	mod reg r/w
----------	-------------

Immediate to Register Memory

1100011w	mod 000 r/w	data	data if w = 1
----------	-------------	------	---------------

Immediate to Register

1011wreg	data	data if w = 1
----------	------	---------------

Memory to Accumulator

1010000w	addr-low	addr-high
----------	----------	-----------

Accumulator to Memory

1010001w	addr-low	addr-high
----------	----------	-----------

Register/Memory to Segment Register

10001110	mod0reg r/w
----------	-------------

Segment Register to Register Memory

10001100	mod0reg r/w
----------	-------------

PUSH = Push

Memory

11111111	mod110 r/w
----------	------------

Register

01010reg

Segment Register

000reg110

Immediate

011010s0	data	data if s = 0
----------	------	---------------

PUSHA = Push All

Push All

01100000

POP = Pop

Memory

10001111	mod000 r/m
----------	------------

Register

01011reg

Segment Register

000reg111	reg \neq 0
-----------	--------------

POPA = Pop All

Pop All

01100001

XCHG = Exchange

Register Memory with Register

100011w	mod reg r/m
---------	-------------

Register with Accumulator

10010reg

IN = Input From

Fixed Port

1110010w	port
----------	------

Variable Port

1110110w

OUT = Output To

Fixed Port

1110011w	port
----------	------

Variable Port

1110111w

XLAT = Translate Byte to AL

Translate Byte to AL

11010111

LEA = Load EA to Register

Load EA to Register

10001101	mod reg r/m
----------	-------------

LDS = Load Pointer to DS

Load Pointer to DS

11000101	mod reg r/m	mod \neq 11
----------	-------------	---------------

LES = Load Pointer to ES

Load Pointer to ES

11000100	mod reg r/m mod \neq 11
----------	---------------------------

LAHF = Load AH with Flags

Load AH with Flags

10011111

SAHF = Load AH with Flags

Store AH with Flags

10011110

PUSHF = Push Flags

Push Flags

10011100

POPF = Pop Flags

Pop Flags

10011101

Arithmetic

ADD = Add

Reg/Memory with Register to Either

000000w	mod reg r/m
---------	-------------

Immediate to Register Memory

100000sw	mod000 r/m	data	data if sw = 01
----------	------------	------	-----------------

Immediate to Accumulator

0000010w	data	data if w = 1
----------	------	---------------

ADC = Add with Carry

Reg/Memory with Register to Either

000100dw	mod reg r/m		
----------	-------------	--	--

Immediate to Register Memory

100000sw	mod000 r/m	data	data if sw = 01
----------	------------	------	-----------------

Immediate to Accumulator

0001010w	data	data if w = 1
----------	------	---------------

INC = Increment**Register/Memory**

1111111w	mod000 r/m		
----------	------------	--	--

Register

01000reg			
----------	--	--	--

SUB = Subtract**Reg/Memory with Register to Either**

001010dw	mod reg r/m		
----------	-------------	--	--

Immediate from Register Memory

100000sw	mod101 r/m	data	data if sw = 01
----------	------------	------	-----------------

Immediate from Accumulator

0010110w	data	data if w = 1
----------	------	---------------

SBB = Subtract with Borrow**Reg/Memory with Register to Either**

000110dw	mod reg r/m		
----------	-------------	--	--

Immediate to Register Memory

100000sw	mod011 r/m	data	data if sw = 01
----------	------------	------	-----------------

Immediate to Accumulator

0001110w	data	data if w = 1
----------	------	---------------

DEC = Decrement**Register/Memory**

1111111w	mod001 r/m
----------	------------

Register

01001reg

CMP = Compare**Register/Memory with Register**

0011101w	mod reg r/m
----------	-------------

Register with Register/Memory

0011100w	mod reg r/m
----------	-------------

Immediate with Register/Memory

100000sw	mod111 r/m	Data	Data if sw = 01
----------	------------	------	-----------------

Immediate with Accumulator

0001110w	Data	Data if w = 1
----------	------	---------------

NEG = Change Sign**Change Sign**

1111011w	mod011 r/m
----------	------------

AAA = ASCII Adjust for Add**ASCII Adjust for Add**

00110111

DEC = Decimal Adjust for Add**Decimal Adjust for Add**

00100111

AAS = ASCII Adjust for Subtract

ASCII Adjust for Subtract

00111111

DAS = Decimal Adjust for Subtract

Decimal Adjust for Subtract

00110111

MUL = Multiply (Unsigned)

Multiply

1111011w	mod100 r/m
----------	------------

IMUL = Integer Multiply (Signed)

Integer Multiply

1111011w	mod101 r/m
----------	------------

IIMUL = Integer Immediate Multiply (Signed)

Integer Immediate Multiply

011010s1	mod reg r/m	Data	Data if s = 0
----------	-------------	------	---------------

DIV = Divide (Unsigned)

Divide

1111011w	mod110 r/m
----------	------------

IDIV = Integer Divide (Signed)

Integer Divide

1111011w	mod111 r/m
----------	------------

AAM = ASCII Adjust for Multiply

ASCII Adjust for Multiply

11010100	00001010
----------	----------

AAD = ASCII Adjust for Divide

ASCII Adjust for Divide

11010101	00001010
----------	----------

CBW = Convert Byte to Word

Convert Byte to Word

10011000

CWD = Convert Word to Double Word

Convert Word to Double Word

10011001

Logic

Shift Rotate Instructions

Register Memory by 1

1101000w	mod TTT r/m
----------	-------------

Register Memory by CL

1101001w	mod TTT r/m
----------	-------------

Register Memory by Count

1100000w	mod TTT r/m	Count
----------	-------------	-------

TTT Instruction

000 ROL
001 ROR
010 RCL
011 RCR
100 SHL/SAL
101 SHR
111 SAR

AND = And

Reg/Memory and Register to Either

001000dw	mod reg r/m
----------	-------------

Immediate to Register Memory

1000000w	mod000 r/m	Data	Data if w = 1
----------	------------	------	---------------

Immediate to Accumulator

0010010w	Data	Data if w = 1
----------	------	---------------

TEST = AND Function to Flags; No Result**Register Memory and Register**

1000010w	mod reg r/m
----------	-------------

Immediate Data and Register Memory

1111011w	mod000 r/m	Data	Data if w=1
----------	------------	------	-------------

Immediate to Accumulator

0000110w	Data	Data if w = 1
----------	------	---------------

Or = Or**Reg/ Memory and Register to Either**

000010dw	mod reg r/m
----------	-------------

Immediate to Register Memory

1000000w	mod001 r/m	Data	Data if w = 1
----------	------------	------	---------------

Immediate to Accumulator

0000110w	Data	Data if w = 1
----------	------	---------------

XOR = Exclusive OR**Reg/Memory and Register to Either**

001100dw	mod reg r/m
----------	-------------

Immediate to Register Memory

1000000w	mod110 r/m	Data	Data if w = 1
----------	------------	------	---------------

Immediate to Accumulator

0010010w	Data	Data if w = 1
----------	------	---------------

NOT = Invert Register/Memory

Invert Register/Memory

1111011w	mod010 r/m
----------	------------

String Manipulation

MOVS = Move Byte Word

Move Byte Word

1010010w

CMPS = Compare Byte Word

Compare Byte Word

1010011w

SCAS = Scan Byte Word

Scan Byte Word

1010111w

LODS = Load Byte Word to AL/AX

Load Byte Word to AL/AX

1010110w

STOS = Store Byte Word from AL/AX

Store Byte Word from AL/AX

1010101w

INS = Input Byte from DX Port

Input Byte Word from DX Port

0110110w

OUTS = Output Byte to DX Port

Output Byte Word to DX Port

0110111w

MOVS = Move String

Move String

11110010	1010010w
----------	----------

CMPS = Compare String

Compare String

1111001z	1010011w
----------	----------

SCAS = Scan String

Scan String

11110010	1010111w
----------	----------

LODS = Load String

Load String

11110010	1010110w
----------	----------

STOS = Store String

Store String

11110010	1010101w
----------	----------

INS = Input String

Input String

11110010	0110110w
----------	----------

OUTS = Output String

Output String

11110010	1010011w
----------	----------

Control Transfer

CALL = Call

Direct Within Segment

11101000	disp-low	disp-low
----------	----------	----------

Register/Memory Indirect Within Segment

11111111	mod010 r/m	
----------	------------	--

Direct Intersegment

10011010	Segment Offset	Segment Selector
----------	----------------	------------------

Protected Mode Only (Direct Intersegment)

- Via call gate to same privilege level
- Via call gate to different privilege level, no parameters
- Via call gate to different privilege level, x parameters
- Via TSS
- Via task gate.

Indirect Intersegment

11111111	mod011 r/m (mod \neq 11)	
----------	----------------------------	--

Protected Mode Only (Indirect Intersegment)

- Via call gate to same privilege level
- Via call gate to different privilege level, no parameters
- Via call gate to different privilege level, x parameters
- Via TSS
- Via task gate.

JMP = Unconditional Jump

Short/Long

11101011	disp-low	
----------	----------	--

Direct within Segment

11101001	disp=low	disp-high
----------	----------	-----------

Register/Memory Indirect Within Segment

11111111	mod100 r/m
----------	------------

Direct Intersegment

11101010	Segment Offset	Segment Selector
----------	----------------	------------------

Protected Mode Only (Direct Intersegment)

- Via call gate to same privilege level
- Via TSS
- Via task gate.

Indirect Intersegment

11111111	mod101 r/m (mod \neq 11)
----------	----------------------------

Protected Mode Only (Indirect Intersegment)

- Via call gate to same privilege level
- Via TSS
- Via task gate.

RET = Return from Call**Within Segment**

11000011

Within Segment Adding Immediate to SP

11000010	data-low	data-high
----------	----------	-----------

Intersegment

11001011

Intersegment Adding Immediate to SP

11001010	data-low	data-high
----------	----------	-----------

Protected Mode Only (RET)

- To Different Privilege Level

JE/JZ = Jump on Equal Zero

Jump on Equal Zero

01110100	disp
----------	------

JL/JNGE = Jump on Less Not Greater, or Equal

Jump on Less Not Greater, or Equal

01111100	disp
----------	------

JLE/JNG = Jump on Less, or Equal Not Greater

Jump on Less, or Equal Not Greater

01111110	disp
----------	------

JB/JNAE = Jump on Less, or Equal Not Greater

Jump on Less, or Equal Not Greater

01110010	disp
----------	------

JBE/JNA = Jump on Below, or Equal Not Above

Jump on Below, or Equal Not Above

01110110	disp
----------	------

JP/JPE = Jump on Parity Parity Even

Jump on Parity Parity Even

01111010	disp
----------	------

JO = Jump on Overflow

Jump on Overflow

01110000	disp
----------	------

JS = Jump on Sign

Jump on Sign

01111000	disp
----------	------

JNE/JNZ = Jump on Not Equal Not Zero

Jump on Not Equal Not Zero

01110101	disp
----------	------

JNL/JGE = Jump on Not Less Greater or Equal

Jump on Not Less Greater or Zero

01111101	disp
----------	------

JNLE/JG = Jump on Not Less or Equal Greater

Jump on Not Less or Equal Greater

01111111	disp
----------	------

JNB/JAE = Jump on Not Below Above or Equal

Jump on Not Below Above or Equal

01110011	disp
----------	------

JNBE/JA = Jump on Not Below or Equal Above

Jump on Not Below or Equal Above

01110111	disp
----------	------

JNP/JPO = Jump on Not Parity Parity Odd

Jump on Not Parity Parity Odd

01111011	disp
----------	------

JNO = Jump on Not Overflow

Jump on Not Overflow

01110001	disp
----------	------

JNS = Jump on Not Sign

Jump on Not Sign

01111011	disp
----------	------

LOOP = Loop CX Times

Loop CX Times

11100010	disp
----------	------

LOOPZ/LOOPE = Loop while Zero Equal

Loop while Zero Equal

11100001	disp
----------	------

LOOPNZ/LOOPNE = Loop while Not Equal Zero

Loop while Not Equal Zero

11100000	disp
----------	------

JCXZ = Jump on CX Zero

Jump on CX Zero

11100011	disp
----------	------

ENTER = Enter Procedure

Enter Procedure

11001000	data-low	data-high	L
----------	----------	-----------	---

L=0

L=1

L>1

LEAVE = Leave Procedure

Leave Procedure

11001001

INT = Interrupt

Type Specified

11001101	Type
----------	------

Type 3

11001100

INTO = Interrupt on Overflow

Interrupt on Overflow

11001110

Protected Mode Only

- Via interrupt or trap gate to same privilege level
- Via interrupt or trap gate to different privilege level
- Via task gate.

IRET = Interrupt Return

Interrupt Return

11001111

Protected Mode Only

- To same privilege level
- To different task (NT = 1).

BOUND = Detect Value Out of Range

Detect Value Out of Range

01100010

mod reg r/m

Processor Control

CLC = Clear Carry

Clear Carry

1111100

CMC = Complement Carry

Complement Carry

11001111

STC = Set Carry

Set Carry

11111001

CLD = Clear Direction

Clear Direction

11111100

STD = Set Direction

Set Direction

11111101

CLI Clear Interrupt

Clear Interrupt

11111010

STI = Set Interrupt

Set Interrupt

11111011

HLT = Halt

Halt

11110100

WAIT = Wait

Wait

10011011

LOCK = Bus Lock Prefix

Bus Lock Prefix

11110000

CTS = Clear Task Switched Flag

Clear Task Switched Flag

00001111	00000110
----------	----------

ESC = Processor Extension Escape

Processor Extension Escape

10011TTT	modLLL r/m
----------	------------

Protection Control

LGDT = Load Global Descriptor Table Register

Load Global Descriptor Table Register

00001111	00000001	mod010 r/m
----------	----------	------------

SGDT = Store Global Descriptor Table Register

Store Global Descriptor Table Register

00001111	00000001	mod000 r/m
----------	----------	------------

LIDT = Load Interrupt Descriptor Table Register

Load Interrupt Descriptor Table Register

00001111	00000001	mod011 r/m
----------	----------	------------

SIDT = Store Interrupt Descriptor Table Register

Store Interrupt Descriptor Table Register

00001111	00000001	mod001 r/m
----------	----------	------------

LLDT = Load Local Descriptor Table Register from Register Memory

Load Local Descriptor Table Register from Register Memory

00001111	00000000	mod010 r/m
----------	----------	------------

SLDT = Store Local Descriptor Table Register from Register Memory

Store Local Descriptor Table Register from Register Memory

00001111	00000000	mod000 r/m
----------	----------	------------

LTR = Load Task Register from Register Memory

Load Task Register from Register Memory

00001111	00000000	mod011 r/m
----------	----------	------------

STR = Store Task Register to Register Memory

Store Task Register to Register Memory

00001111	00000000	mod001 r/m
----------	----------	------------

LMSW = Load Machine Status Word from Register Memory

Load Machine Status Word from Register Memory

00001111	00000001	mod110 r/m
----------	----------	------------

SMSW = Store Machine Status Word

Store Machine Status Word

00001111	00000001	mod100 r/m
----------	----------	------------

LAR = Load Access Rights from Register Memory

Load Access Rights from Register Memory

00001111	00000010	mod reg r/m
----------	----------	-------------

LSL = Load Segment Limit from Register Memory

Load Segment Limit from Register Memory

00001111	00000011	mod reg r/m
----------	----------	-------------

ARPL = Adjust Requested Privilege Level from Register Memory

Adjust Requested Privilege Level from Register Memory

	01100011	mod reg r/m
--	----------	-------------

VERR = Verify Read Access; Register Memory

Verify Read Access; Register Memory

00001111	00000000	mod100 r/m
----------	----------	------------

VERR = Verify Write Access

Verify Write Access

00001111	00000000	mod101 r/m
----------	----------	------------

Note: The effective address (EA) of the memory operand is computed according to the mod and r/m fields:

If mod = 11, then r/m is treated as a reg field.

If mod = 00, then disp = 0, disp-low and disp-high are absent.

If $\text{mod} = 01$, then $\text{disp} = \text{disp-low}$ sign-extended to 16 bits, disp-high is absent.

If $\text{mod} = 10$, then $\text{disp} = \text{disp-high}:\text{disp-low}$.

If $r/m = 000$, then $\text{EA} = (\text{BX}) + (\text{SI}) + \text{disp}$

If $r/m = 001$, then $\text{EA} = (\text{BX}) + (\text{SI}) + \text{disp}$

If $r/m = 010$, then $\text{EA} = (\text{BP}) + (\text{SI}) + \text{disp}$

If $r/m = 011$, then $\text{EA} = (\text{BP}) + (\text{DI}) + \text{disp}$

If $r/m = 100$, then $\text{EA} = (\text{SI}) + \text{disp}$

If $r/m = 101$, then $\text{EA} = (\text{DI}) + \text{disp}$

If $r/m = 110$, then $\text{EA} = (\text{BP}) + \text{disp}$

If $r/m = 111$, then $\text{EA} = (\text{BX}) + \text{disp}$

disp follows the second byte of the instruction (before data if required).

Segment Override Prefix

Segment Override Prefix

001reg001

reg is assigned as follows:

reg **Segment Register**

00 **ES**

01 **CS**

10 **SS**

11 **DS**

16-bit ($w = 1$)	8-bit ($w = 0$)
000 AX	000 AL
001 CX	001 CL
010 DX	010 DL
011 BX	011 BL
100 SP	100 AH
101 BP	101 CH
110 SI	110 DH
111 DI	111 BH

The physical addresses of all operands addressed by the BP register are computed using the SS segment register. The physical addresses of the destination operands of the string primitive operations (those addressed by the DI register) are computed using the ES segment, which may not be overridden.

80287 Coprocessor Instruction Set

The following is an instruction set summary for the 80287 coprocessor.

Data Transfer

FLD = Load

Integer/Real Memory to ST(0)

escape MF 1	mod 000 r/m
-------------	-------------

Long Integer Memory to ST(0)

escape 111	mod 101 r/m
------------	-------------

Temporary Real Memory to ST(0)

escape 011	mod 101 r/m
------------	-------------

BCD Memory to ST(0)

escape 111	mod 100 r/m
------------	-------------

ST(i) to ST(0)

escape 001	11000ST(i)
------------	------------

FST = Store

ST(0) to Integer/Real Memory

escape MF 1	mod 010 r/m
-------------	-------------

ST(0) to ST(i)

escape 101	11010 ST(i)
------------	-------------

FSTP = Store and Pop

ST(0) to Integer/Real Memory

escape MF 1	mod 011 r/m
-------------	-------------

ST(0) to Long Integer Memory

escape 111	mod 111 r/m
------------	-------------

ST(0) to Temporary Real Memory

escape 011	mod 111 r/m
------------	-------------

ST(0) to BCD Memory

escape 111	mod 110 r/m
------------	-------------

ST(0) to ST(i)

escape 101	11011 ST(i)
------------	-------------

FXCH = Exchange ST(i) and ST(0)

Exchange ST(i) and ST(0)

escape 001	11001 ST(i)
------------	-------------

Comparison

FCOM = Compare

Integer/Real Memory to ST(0)

escape MF 0	mod 010 r/m
-------------	-------------

ST(i) to ST(0)

escape 000	11010 ST(i)
------------	-------------

FCOMP = Compare and Pop

Integer/Real Memory to ST(0)

escape MF 0	mod 011 r/m
-------------	-------------

ST(i) to ST(0)

escape 000	11010 ST(i)
------------	-------------

FCOMPP = Compare ST(i) to ST(0) and Pop Twice

Compare ST(i) to ST(0) and pop twice

escape 110	11011001
------------	----------

FTST = Test ST(0)

Test ST(0)

escape 001	11100100
------------	----------

FXAM = Examine ST(0)

Examine ST(0)

escape 001	11100101
------------	----------

Constants

FLDZ = Load + 0.0 into ST(0)

Load + 0.0 into ST(0)

escape 000	11101110
------------	----------

FLD1 = Load + 1.0 into ST(0)

Load + 1.0 into ST(0)

escape 001	11101000
------------	----------

FLDP1 = Load π into ST(0) π into ST(0)

Load

escape 001	11101011
------------	----------

FLDL2T = Load $\log_2 10$ into ST(0) $2 \log_2 10$ into ST(0)

Load log

escape 001	11101001
------------	----------

FLDLG2 = Load $\log_{10} 2$ into ST(0) $_{10} 2$ into ST(0)

Load log

escape 001	11101100
------------	----------

FLDLN2 = Load $\log_e 2$ into ST(0) $_e 2$ into ST(0)

Load log

escape 001	11101101
------------	----------

Arithmetic

FADD = Addition

Integer/Real Memory with ST(0)

escape MF 0	mod 000 r/m
-------------	-------------

ST(i) and ST(0)

escape dP0	11000 ST(i)
------------	-------------

FSUB = Subtraction

Integer/Real Memory with ST(0)

escape MF 0	mod 10r r/m
-------------	-------------

ST(i) and ST(0)

escape dP0	1110r r/m
------------	-----------

FMUL = Multiplication

Integer/Real Memory with ST(0)

escape MF 0	mod 001 r/m
-------------	-------------

ST(i) and ST(0)

escape dP0	11001 r/m
------------	-----------

FDIV = Division

Integer/Real Memory with ST(0)

escape MF 0	mod 11r r/m
-------------	-------------

ST(i) and ST(0)

escape dPO	1111 r r/m
------------	------------

FSQRT = Square Root of ST(0)

Square Root of ST(0)

escape 001	11111010
------------	----------

FSCALE = Scale ST(0) by ST(1)

Scale ST(0) by ST(1)

escape 001	11111101
------------	----------

FPREM = Partial Remainder of ST(0) + ST(1)

Partial Remainder of ST(0) + ST(1)

escape 001	11111000
------------	----------

FRNDINT = Round ST(0) to Integer

Round ST(0) to Integer

escape 001	11111100
------------	----------

FXTRACT = Extract Components of ST(0)

Extract Components of ST(0)

escape 001	11110100
------------	----------

FABS = Absolute Value of ST(0)

Absolute Value of ST(0)

escape 001	11100001
------------	----------

FCHS = Change Sign of ST(0)

Change Sign of ST(0)

escape 001	11100000
------------	----------

Transcendental

FPTAN = Partial Tangent of ST(0)

Partial Tangent of ST(0)

escape 001	11110010
------------	----------

FPATAN = Partial Arc tangent of ST(0) ÷ ST(1)

Partial Arc tangent of ST(0) ÷ ST(1)

escape 001	11110011
------------	----------

F2XM1 = 2^{ST(0)}-1 ST(0)₋₁

escape 001	11110000
------------	----------

FYL2X = ST(1) x Log₂ [ST(0)]₂ [ST(0)]

ST(1) x log

escape 001	11110001
------------	----------

FYL2XP1 = ST(1) x Log₂ [ST(0) + 1]₂ [ST(0) + 1]

ST(1) x log

escape 001	11111001
------------	----------

Processor Control

FINT = Initialize NPX

Initialize NPX

escape 011	11100011
------------	----------

FSETPM = Enter Protected Mode

Enter Protected Mode

escape 011	11100100
------------	----------

FSTSWAX = Store Control Word

Store Control Word

escape 111	11100000
------------	----------

FLDCW = Load Control Word

Load Control Word

escape 001	mod 101 r/m
------------	-------------

FSTCW = Store Control Word

Store Control Word

escape 001	mod 111 r/m
------------	-------------

FSTSW = Store Status Word

Store Status Word

escape 101	mod 101 r/m
------------	-------------

FCLEX = Clear Exceptions

Clear Exceptions

escape 011	11100010
------------	----------

FSTENV = Store Environment

Store Environment

escape 001	mod 110 r/m
------------	-------------

FLDENV = Load Environment

Load Environment

escape 001	mod 100 r/m
------------	-------------

FSAVE = Save State

Save State

escape 101	mod 110 r/m
------------	-------------

FRSTOR = Restore State

Restore State

escape 101	mod 100 r/m
------------	-------------

FINCSTP = Increment Stack Pointer

Increment Stack Pointer

escape 001	11110111
------------	----------

FDECSTP = Decrement Stack Pointer

Decrement Stack Pointer

escape 001	11110110
------------	----------

FFREE = Free ST(i)

Free ST(i)

escape 101	11000ST(i)
------------	------------

FNOP = No Operation

No Operation

escape 001	11010000
------------	----------

Notes:



SECTION 7. CHARACTERS, KEYSTROKES, AND COLORS

Contents

Characters, Keystrokes, and Color	7-3
NOTES	7-13

Notes:



Characters, Keystrokes, and Color

Value		As Characters			As Text Attributes		
					Color/Graphics Monitor Adapter		IBM Monochrome Display Adapter
Hex	Dec	Symbol	Keystrokes	Modes	Background	Foreground	
00	0	Blank (Null)	Ctrl 2		Black	Black	Non-Display
01	1	☺	Ctrl A		Black	Blue	Underline
02	2	☹	Ctrl B		Black	Green	Normal
03	3	♥	Ctrl C		Black	Cyan	Normal
04	4	♦	Ctrl D		Black	Red	Normal
05	5	♣	Ctrl E		Black	Magenta	Normal
06	6	♠	Ctrl F		Black	Brown	Normal
07	7	•	Ctrl G		Black	Light Grey	Normal
08	8	•	Ctrl H, Backspace, Shift Backspace		Black	Dark Grey	Non-Display
09	9	○	Ctrl I		Black	Light Blue	High Intensity Underline
0A	10	○	Ctrl J, Ctrl ↵		Black	Light Green	High Intensity
0B	11	♂	Ctrl K		Black	Light Green	High Intensity
0C	12	♀	Ctrl L		Black	Light Red	High Intensity
0D	13	♪	Ctrl M, ↵, Shift ↵		Black	Light Magenta	High Intensity
0E	14	♪	Ctrl N		Black	Yellow	High Intensity
0F	15	☼	Ctrl O		Black	White	High Intensity
10	16	▶	Ctrl P		Blue	Black	Normal
11	17	◀	Ctrl Q		Blue	Blue	Underline
12	18	↕	Ctrl R		Blue	Green	Normal
13	19	!!	Ctrl S		Blue	Cyan	Normal
14	20	¶	Ctrl T		Blue	Red	Normal
15	21	§	Ctrl U			Magenta	Normal
16	22	■	Ctrl V		Blue	Brown	Normal
17	23	↕	Ctrl W		Blue	Light Grey	Normal

Value		As Characters			As Text Attributes		
					Color/Graphics Monitor Adapter		IBM Monochrome Display Adapter
Hex	Dec	Symbol	Keystrokes	Modes	Background	Foreground	
18	24	↑	Ctrl X		Blue	Dark Grey	High Intensity
19	25	↓	Ctrl Y		Blue	Light Blue	High Intensity Underline
1A	26	→	Ctrl Z		Blue	Light Green	High Intensity
1B	27	—	Ctrl [, Esc, Shift Esc, Ctrl Esc		Blue	Light Cyan	High Intensity
1C	28	└	Ctrl \		Blue	Light Red	High Intensity
1D	29	↔	Ctrl]		Blue	Light Magenta	High Intensity
1E	30	▲	Ctrl 6		Blue	Yellow	High Intensity
1F	31	▼	Ctrl —		Blue	White	High Intensity
20	32	Blank Space	Space Bar, Shift, Space, Ctrl Space, Alt Space		Green	Black	Normal
21	33			Shift	Green	Blue	Underline
22	34	''	''	Shift	Green	Green	Normal
23	35	#	#	Shift	Green	Cyan	Normal
24	36	\$ `	\$	Shift	Green	Red	Normal
25	37	%	%	Shift	Green	Magenta	Normal
26	38	&	&	Shift	Green	Brown	Normal
27	39	'	'		Green	Light Grey	Normal
28	40	((Shift	Green	Dark Grey	High Intensity
29	41))	Shift	Green	Light Blue	High Intensity Underline
2A	42	*	*	Note 1	Green	Light Green	High Intensity
2B	43	+	+	Shift	Green	Light Cyan	High Intensity
2C	44	'	'		Green	Light Red	High Intensity
2D	45	—	—		Green	Light Magenta	High Intensity
2E	46	.	.	Note 2	Green	Yellow	High Intensity

7-4 Characters, Keystrokes, and Color

Value		As Characters			As Text Attributes		
					Color/Graphics Monitor Adapter		IBM Monochrome Display Adapter
Hex	Dec	Symbol	Keystrokes	Modes	Background	Foreground	
2F	47	/	/		Green	White	High Intensity
30	48	0	0	Note 3	Cyan	Black	Normal
31	49	1	1	Note 3	Cyan	Blue	Underline
32	50	2	2	Note 3	Cyan	Green	Normal
33	51	3	3	Note 3	Cyan	Cyan	Normal
34	52	4	4	Note 3	Cyan	Red	Normal
35	53	5	5	Note 3	Cyan	Magenta	Normal
36	54	6	6	Note 3	Cyan	Brown	Normal
37	55	7	7	Note 3	Cyan	Light Grey	Normal
38	56	8	8	Note 3	Cyan	Dark Grey	High Intensity
39	57	9	9	Note 3	Cyan	Light Blue	High Intensity Underline
3A	58	:	:	Shift	Cyan	Light Green	High Intensity
3B	59	;	;		Cyan	Light Cyan	High Intensity
3C	60	<	<	Shift	Cyan	Light Red	High Intensity
3D	61	=	=		Cyan	Light Magenta	High Intensity
3E	62	>	>	Shift	Cyan	Yellow	High Intensity
3F	63	?	?	Shift	Cyan	White	High Intensity
40	64	@	@	Shift	Red	Black	Normal
41	65	A	A	Note 4	Red	Blue	Underline
42	66	B	B	Note 4	Red	Green	Normal
43	67	C	C	Note 4	Red	Cyan	Normal
44	68	D	D	Note 4	Red	Red	Normal
45	69	E	E	Note 4	Red	Magenta	Normal
46	70	F	F	Note 4	Red	Brown	Normal
47	71	G	G	Note 4	Red	Light Grey	Normal
48	72	H	H	Note 4	Red	Dark Grey	High Intensity
49	73	I	I	Note 4	Red	Light Blue	High Intensity Underline
4A	74	J	J	Note 4	Red	Light Green	High Intensity

Value		As Characters			As Text Attributes		
					Color/Graphics Monitor Adapter		IBM Monochrome Display Adapter
Hex	Dec	Symbol	Keystrokes	Modes	Background	Foreground	
4B	75	K	K	Note 4	Red	Light Cyan	High Intensity
4C	76	L	L	Note 4	Red	Light Red	High Intensity
4D	77	M	M	Note 4	Red	Light Magenta	High Intensity
4E	78	N	N	Note 4	Red	Yellow	High Intensity
4F	79	O	O	Note 4	Red	White	High Intensity
50	80	P	P	Note 4	Magenta	Black	Normal
51	81	Q	Q	Note 4	Magenta	Blue	Underline
52	82	R	R	Note 4	Magenta	Green	Normal
53	83	S	S	Note 4	Magenta	Cyan	Normal
54	84	T	T	Note 4	Magenta	Red	Normal
55	85	U	U	Note 4	Magenta	Magenta	Normal
56	86	V	V	Note 4	Magenta	Brown	Normal
57	87	W	W	Note 4	Magenta	Light Grey	Normal
58	88	X	X	Note 4	Magenta	Dark Grey	High Intensity
59	89	Y	Y	Note 4	Magenta	Light Blue	High Intensity Underline
5A	90	Z	Z	Note 4	Magenta	Light Green	High Intensity
5B	91	[[Magenta	Light Cyan	High Intensity
5C	92	\	\		Magenta	Light Red	High Intensity
5D	93]]		Magenta	Light Magenta	High Intensity
5E	94	^	^	Shift	Magenta	Yellow	High Intensity
5F	95	—	—	Shift	Magenta	White	High Intensity
60	96	·	·		Yellow	Black	Normal
61	97	a	a	Note 5	Yellow	Blue	Underline
62	98	b	b	Note 5	Yellow	Green	Normal
63	99	c	c	Note 5	Yellow	Cyan	Normal
64	100	d	d	Note 5	Yellow	Red	Normal
65	101	e	e	Note 5	Yellow	Magenta	Normal
66	102	f	f	Note 5	Yellow	Brown	Normal

Value		As Characters			As Text Attributes		
					Color/Graphics Monitor Adapter		IBM Monochrome Display Adapter
Hex	Dec	Symbol	Keystrokes	Modes	Background	Foreground	
67	103	g	g	Note 5	Yellow	Light Grey	Normal
68	104	h	h	Note 5	Yellow	Dark Grey	High Intensity
69	105	i	i	Note 5	Yellow	Light Blue	High Intensity Underline
6A	106	j	j	Note 5	Yellow	Light Green	High Intensity
6B	107	k	k	Note 5	Yellow	Light Cyan	High Intensity
6C	108	l	l	Note 5	Yellow	Light Red	High Intensity
6D	109	m	m	Note 5	Yellow	Light Magenta	High Intensity
6E	110	n	n	Note 5	Yellow	Yellow	High Intensity
6F	111	o	o	Note 5	Yellow	White	High Intensity
70	112	p	p	Note 5	White	Black	Reverse Video
71	113	q	q	Note 5	White	Blue	Underline
72	114	r	r	Note 5	White	Green	Normal
73	115	s	s	Note 5	White	Cyan	Normal
74	116	f	f	Note 5	White	Red	Normal
75	117	u	u	Note 5	White	Magenta	Normal
76	118	v	v	Note 5	White	Brown	Normal
77	119	w	w	Note 5	White	Light Grey	Normal
78	120	x	x	Note 5	White	Dark Grey	Reverse Video
79	121	y	y	Note 5	White	Light Blue	High Intensity Underline
7A	122	z	z	Note 5	White	Light Green	High Intensity
7B	123	{	{	Shift	White	Light Cyan	High Intensity
7C	124			Shift	White	Light Red	High Intensity
7D	125	}	}	Shift	White	Light Magenta	High Intensity
7E	126	~	~	Shift	White	Yellow	High Intensity
7F	127	Δ	Ctrl -		White	White	High Intensity

Value		As Characters			As Text Attributes		
					Color/Graphics Monitor Adapter		IBM Monochrome Display Adapter
Hex	Dec	Symbol	Keystrokes	Modes	Background	Foreground	
* * * * 80 to FF Hex are Flashing in both Color & IBM Monochrome * * * *							
80	128	Ç	Alt 128	Note 6	Black	Black	Non-Display
81	129	ü	Alt 129	Note 6	Black	Blue	Underline
82	130	é	Alt 130	Note 6	Black	Green	Normal
83	131	â	Alt 131	Note 6	Black	Cyan	Normal
84	132	ä	Alt 132	Note 6	Black	Red	Normal
85	133	à	Alt 133	Note 6	Black	Magenta	Normal
86	134	á	Alt 134	Note 6	Black	Brown	Normal
87	135	ç	Alt 135	Note 6	Black	Light Grey	Normal
88	136	ê	Alt 136	Note 6	Black	Dark Grey	Non-Display
89	137	ë	Alt 137	Note 6	Black	Light Blue	High Intensity Underline
8A	138	è	Alt 138	Note 6	Black	Light Green	High Intensity
8B	139	ï	Alt 139	Note 6	Black	Light Cyan	High Intensity
8C	140	î	Alt 140	Note 6	Black	Light Red	High Intensity
8D	141	ì	Alt 141	Note 6	Black	Light Magenta	High Intensity
8E	142	Á	Alt 142	Note 6	Black	Yellow	High Intensity
8F	143	À	Alt 143	Note 6	Black	White	High Intensity
90	144	É	Alt 144	Note 6	Blue	Black	Normal
91	145	æ	Alt 145	Note 6	Blue	Blue	Underline
92	146	Æ	Alt 146	Note 6	Blue	Green	Normal
93	147	ô	Alt 147	Note 6	Blue	Cyan	Normal
94	148	ö	Alt 148	Note 6	Blue	Red	Normal
95	149	ò	Alt 149	Note 6	Blue	Magenta	Normal
96	150	û	Alt 150	Note 6	Blue	Brown	Normal
97	151	ù	Alt 151	Note 6	Blue	Light Grey	Normal
98	152	ÿ	Alt 152	Note 6	Blue	Dark Grey	High Intensity
99	153	ö	Alt 153	Note 6	Blue	Light Blue	High Intensity Underline
9A	154	ü	Alt 154	Note 6	Blue	Light Green	High Intensity

7-8 Characters, Keystrokes, and Color

Value		As Characters			As Text Attributes		
					Color/Graphics Monitor Adapter		IBM Monochrome Display Adapter
Hex	Dec	Symbol	Keystrokes	Modes	Background	Foreground	
9B	155	¢	Alt 155	Note 6	Blue	Light Cyan	High Intensity
9C	156	£	Alt 156	Note 6	Blue	Light Red	High Intensity
9D	157	¥	Alt 157	Note 6	Blue	Light Magenta	High Intensity
9E	158	Pt	Alt 158	Note 6	Blue	Yellow	High Intensity
9F	159	∫	Alt 159	Note 6	Blue	White	High Intensity
A0	160	á	Alt 160	Note 6	Green	Black	Normal
A1	161	í	Alt 161	Note 6	Green	Blue	Underline
A2	162	ó	Alt 162	Note 6	Green	Green	Normal
A3	163	ú	Alt 163	Note 6	Green	Cyan	Normal
A4	164	ñ	Alt 164	Note 6	Green	Red	Normal
A5	165	Ñ	Alt 165	Note 6	Green	Magenta	Normal
A6	166	<u>a</u>	Alt 166	Note 6	Green	Brown	Normal
A7	167	<u>o</u>	Alt 167	Note 6	Green	Light Grey	Normal
A8	168	¿	Alt 168	Note 6	Green	Dark Grey	High Intensity
A9	169	┌	Alt 169	Note 6	Green	Light Blue	High Intensity Underline
AA	170	└	Alt 170	Note 6	Green	Light Green	High Intensity
AB	171	½	Alt 171	Note 6	Green	Light Cyan	High Intensity
AC	172	¼	Alt 172	Note 6	Green	Light Red	High Intensity
AD	173	ı	Alt 173	Note 6	Green	Light Magenta	High Intensity
AE	174	<<	Alt 174	Note 6	Green	Yellow	High Intensity
AF	175	>>	Alt 175	Note 6	Green	White	High Intensity
B0	176	⋮	Alt 176	Note 6	Cyan	Black	Normal
B1	177	⋈	Alt 177	Note 6	Cyan	Blue	Underline
B2	178	⋊	Alt 178	Note 6	Cyan	Green	Normal
B3	179		Alt 179	Note 6	Cyan	Cyan	Normal
B4	180	▬	Alt 180	Note 6	Cyan	Red	Normal
B5	181	▬	Alt 181	Note 6	Cyan	Magenta	Normal
B6	182	▬	Alt 182	Note 6	Cyan	Brown	Normal

Value		As Characters			As Text Attributes		
					Color/Graphics Monitor Adapter		IBM Monochrome Display Adapter
Hex	Dec	Symbol	Keystrokes	Modes	Background	Foreground	
B7	183		Alt 183	Note 6	Cyan	Light Grey	Normal
B8	184		Alt 184	Note 6	Cyan	Dark Grey	High Intensity
B9	185		Alt 185	Note 6	Cyan	Light Blue	High Intensity Underline
BA	186		Alt 186	Note 6	Cyan	Light Green	High Intensity
BB	187		Alt 187	Note 6	Cyan	Light Cyan	High Intensity
BC	188		Alt 188	Note 6	Cyan	Light Red	High Intensity
BD	189		Alt 189	Note 6	Cyan	Light Magenta	High Intensity
BE	190		Alt 190	Note 6	Cyan	Yellow	High Intensity
BF	191		Alt 191	Note 6	Cyan	White	High Intensity
C0	192		Alt 192	Note 6	Red	Black	Normal
C1	193		Alt 193	Note 6	Red	Blue	Underline
C2	194		Alt 194	Note 6	Red	Green	Normal
C3	195		Alt 195	Note 6	Red	Cyan	Normal
C4	196		Alt 196	Note 6	Red	Red	Normal
C5	197		Alt 197	Note 6	Red	Magenta	Normal
C6	198		Alt 198	Note 6	Red	Brown	Normal
C7	199		Alt 199	Note 6	Red	Light Grey	Normal
C8	200		Alt 200	Note 6	Red	Dark Grey	High Intensity
C9	201		Alt 201	Note 6	Red	Light Blue	High Intensity Underline
CA	202		Alt 202	Note 6	Red	Light Green	High Intensity
CB	203		Alt 203	Note 6	Red	Light Cyan	High Intensity
CC	204		Alt 204	Note 6	Red	Light Red	High Intensity
CD	205		Alt 205	Note 6	Red	Light Magenta	High Intensity
CE	206		Alt 206	Note 6	Red	Yellow	High Intensity
CF	207		Alt 207	Note 6	Red	White	High Intensity
DO	208		Alt 208	Note 6	Magenta	Black	Normal

7-10 Characters, Keystrokes, and Color

Value		As Characters			As Text Attributes		
					Color/Graphics Monitor Adapter		IBM Monochrome Display Adapter
Hex	Dec	Symbol	Keystrokes	Modes	Background	Foreground	
D1	209		Alt 209	Note 6	Magenta	Blue	Underline
D2	210		Alt 210	Note 6	Magenta	Green	Normal
D3	211		Alt 211	Note 6	Magenta	Cyan	Normal
D4	212		Alt 212	Note 6	Magenta	Red	Normal
D5	213		Alt 213	Note 6	Magenta	Magenta	Normal
D6	214		Alt 214	Note 6	Magenta	Brown	Normal
D7	215		Alt 215	Note 6	Magenta	Light Grey	Normal
D8	216		Alt 216	Note 6	Magenta	Dark Grey	High Intensity
D9	217		Alt 217	Note 6	Magenta	Light Blue	High Intensity Underline
DA	218		Alt 218	Note 6	Magenta	Light Green	High Intensity
DB	219		Alt 219	Note 6	Magenta	Light Cyan	High Intensity
DC	220		Alt 220	Note 6	Magenta	Light Red	High Intensity
DD	221		Alt 221	Note 6	Magenta	Light Magenta	High Intensity
DE	222		Alt 222	Note 6	Magenta	Yellow	High Intensity
DF	223		Alt 223	Note 6	Magenta	White	High Intensity
E0	224	α	Alt 224	Note 6	Yellow	Black	Normal
E1	225	β	Alt 225	Note 6	Yellow	Blue	Underline
E2	226	Γ	Alt 226	Note 6	Yellow	Green	Normal
E3	227	π	Alt 227	Note 6	Yellow	Cyan	Normal
E4	228	Σ	Alt 228	Note 6	Yellow	Red	Normal
E5	229	σ	Alt 229	Note 6	Yellow	Magenta	Normal
E6	230	μ	Alt 230	Note 6	Yellow	Brown	Normal
E7	231	τ	Alt 231	Note 6	Yellow	Light Grey	Normal
E8	232	Φ	Alt 232	Note 6	Yellow	Dark Grey	High Intensity
E9	233	θ	Alt 233	Note 6	Yellow	Light Blue	High Intensity Underline
EA	234	Ω	Alt 234	Note 6	Yellow	Light Green	High Intensity
EB	235	δ	Alt 235	Note 6	Yellow	Light Cyan	High Intensity

Value		As Characters			As Text Attributes		
					Color/Graphics Monitor Adapter		IBM Monochrome Display Adapter
Hex	Dec	Symbol	Keystrokes	Modes	Background	Foreground	
EC	236	∞	Alt 236	Note 6	Yellow	Light Red	High Intensity
ED	237	ϕ	Alt 237	Note 6	Yellow	Light Magenta	High Intensity
EE	238	€	Alt 238	Note 6	Yellow	Yellow	High Intensity
EF	239	∩	Alt 239	Note 6	Yellow	White	High Intensity
F0	240	≡	Alt 240	Note 6	White	Black	Reverse Video
F1	241	±	Alt 241	Note 6	White	Blue	Underline
F2	242	∞	Alt 242	Note 6	White	Green	Normal
F3	243	∞	Alt 243	Note 6	White	Cyan	Normal
F4	244	∫	Alt 244	Note 6	White	Red	Normal
F5	245	∫	Alt 245	Note 6	White	Magenta	Normal
F6	246	÷	Alt 246	Note 6	White	Brown	Normal
F7	247	≈	Alt 247	Note 6	White	Light Grey	Normal
F8	248	○	Alt 248	Note 6	White	Dark Grey	Reverse Video
F9	249	●	Alt 249	Note 6	White	Light Blue	High Intensity Underline
FA	250	•	Alt 250	Note 6	White	Light Green	High Intensity
FB	251	√	Alt 251	Note 6	White	Light Cyan	High Intensity
FC	252	η	Alt 252	Note 6	White	Light Red	High Intensity
FD	253	2	Alt 253	Note 6	White	Light Magenta	High Intensity
FE	254	■	Alt 254	Note 6	White	Yellow	High Intensity
FF	255	BLANK	Alt 255	Note 6	White	White	High Intensity

NOTES

1. Asterisk (*) can be typed using two methods: press the PrtSc key or, in the shift mode, press the 8 key.
2. Period (.) can be typed using two methods: press the . key or, in the shift or Num Lock mode, press the Del key.
3. Numeric characters 0-9 can be typed using two methods: press the numeric keys on the top row of the keyboard or, in the shift or Num Lock mode, press the numeric keys in the keypad portion of the keyboard.
4. Uppercase alphabetic characters (A-Z) can be typed in two modes: the shift mode or the Caps Lock mode.
5. Lowercase alphabetic characters (a-z) can be typed in two modes: in the normal mode or in Caps Lock and shift mode combined.
6. The three digits after the Alt key must be typed from the numeric keypad. Character codes 0-255 may be entered in this fashion (with Caps Lock activated, character codes 97-122 will display uppercase.)

DECIMAL VALUE		0	16	32	48	64	80	96	112
	HEXA DECIMAL VALUE	0	1	2	3	4	5	6	7
0	0	BLANK (NULL)		BLANK (SPACE)	0	@	P	'	p
1	1			!	1	A	Q	a	q
2	2			"	2	B	R	b	r
3	3		!!	#	3	C	S	c	s
4	4		¶	\$	4	D	T	d	t
5	5		§	%	5	E	U	e	u
6	6		■	&	6	F	V	f	v
7	7	•		'	7	G	W	g	w
8	8	●	↑	(8	H	X	h	x
9	9	○	↓)	9	I	Y	i	y
10	A	◉	→	*	:	J	Z	j	z
11	B	♂	←	+	;	K	I	k	{
12	C	♀	└	,	<	L	\	l	!
13	D	🎵	↔	—	=	M	J	m	}
14	E	🎶	▲	.	>	N	^	n	~
15	F	☀	▼	/	?	O	_	o	△

7-14 Characters, Keystrokes, and Color

DECIMAL VALUE	➡	128	144	160	176	192	208	224	240
↩	HEXA DECIMAL VALUE	8	9	A	B	C	D	E	F
0	0	Ç	É	á	⋮	⌌	⌌	∞	≡
1	1	ü	æ	í	⋮	⌌	⌌	β	±
2	2	é	Æ	ó	⋮	⌌	⌌	Γ	≥
3	3	â	ô	ú	⌌	⌌	⌌	π	≤
4	4	ä	ö	ñ	⌌	⌌	⌌	Σ	∫
5	5	à	ò	Ñ	⌌	⌌	⌌	σ	∫
6	6	å	û	ã	⌌	⌌	⌌	μ	÷
7	7	ç	ù	ó	⌌	⌌	⌌	τ	≈
8	8	ê	ÿ	ı	⌌	⌌	⌌	ϕ	◦
9	9	ë	Ö	┐	⌌	⌌	⌌	θ	•
10	A	è	Ü	┐	⌌	⌌	⌌	Ω	•
11	B	ï	ç	½	⌌	⌌	⌌	δ	√
12	C	î	£	¼	⌌	⌌	⌌	∞	n
13	D	ì	¥	ı	⌌	⌌	⌌	φ	²
14	E	Ä	℞	«	⌌	⌌	⌌	€	■
15	F	Å	ƒ	»	⌌	⌌	⌌	∩	BLANK 'FF'

Notes:



SECTION 8. COMMUNICATIONS

Contents

Communications	8-3
Establishing a Data Link	8-6

Notes:



Communications

Information-processing equipment used for communication is called data terminal equipment (DTE.) Equipment used to connect the DTE to the communication line is called data communication equipment (DCE.)

An adapter connects the data terminal equipment to the data communication line as shown in the following figure:

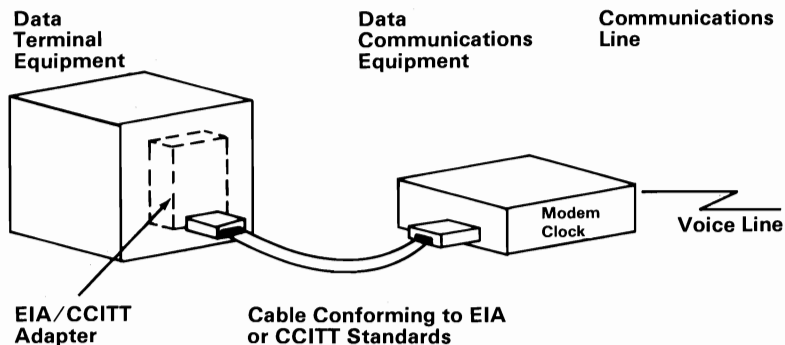

The EIA/CCITT adapter allows the DTE to be connected to the DCE using EIA or CCITT standardized connections. An external modem is shown in the figure; however, other types of DCE also can be connected to the DTE using EIA or CCITT standardized connections.

EIA standards are labeled RS-x (recommended standards-x), and CCITT standards are labeled V.x or X.x, where x is the number of the standard.

The EIA RS-232 interface standard defines the connector type, pin numbers, line names, and signal levels used to connect data terminal equipment to data communications equipment for the purpose of transmitting and receiving data. Since the RS-232 standard was developed, it has been revised three times. The three revised standards are RS-232A, RS-232B, and the presently used RS-232C.

The CCITT V.24 interface standard is equivalent to the RS-232C standard; therefore, the descriptions of the EIA standards also apply to the CCITT standards.

The following is an illustration of data terminal equipment connected to an external modem using connections defined by the RS-232C interface standard:

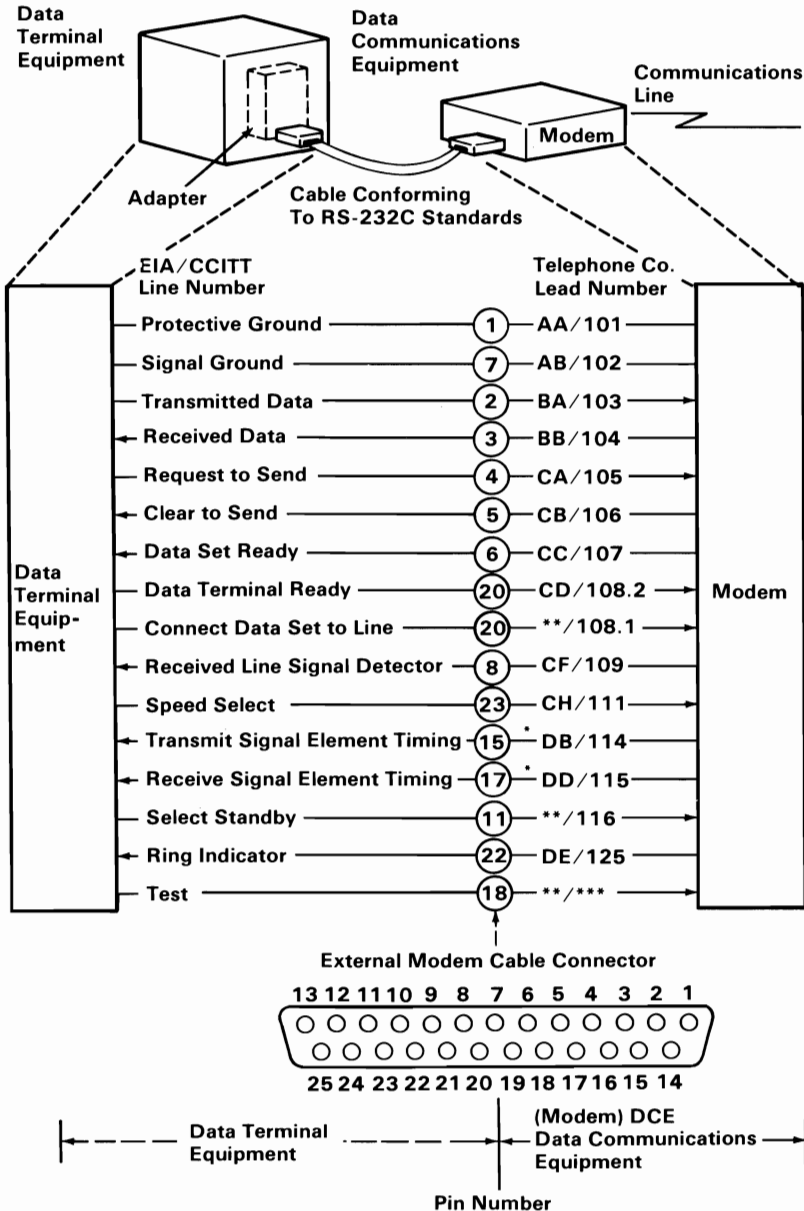

*Not used when business machine clocking is used.
 **Not standardized by EIA (Electronics Industry Association).
 ***Not standardized by CCITT

8-4 Communications

Establishing a Data Link

The following bar graphs represent normal timing sequences of operation during the establishment of communication for both switched (dial-up) and nonswitched (direct line) networks.

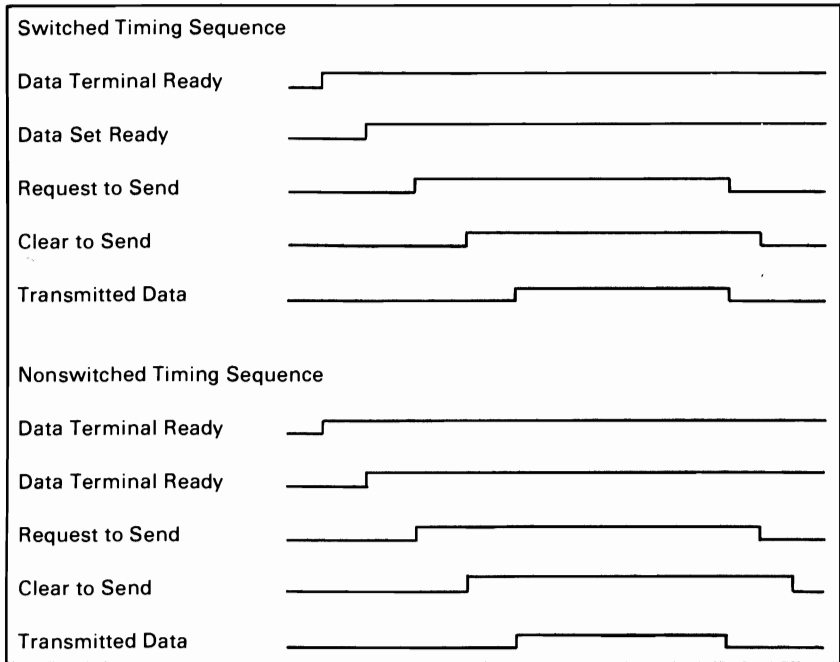

The following examples show how a link is established on a nonswitched point-to-point line, a nonswitched multipoint line, and a switched point-to-point line.

Establishing a Link on a Nonswitched Point-to-Point Line

- The terminals at both locations activate the 'data terminal ready' lines **1** and **8**.
- Normally the 'data set ready' lines **2** and **9** from the modems are active whenever the modems are powered on.
- Terminal A activates the 'request to send' line **3**, which causes the modem at terminal A to generate a carrier signal.
- Modem B detects the carrier, and activates the 'received line signal detector' line (sometimes called data carrier detect) **10**. Modem B also activates the 'receiver signal element timing' line (sometimes called receive clock) **11** to send receive clock signals to the terminal. Some modems activate the clock signals whenever the modem is powered on.
- After a specified delay, modem A activates the 'clear to send' line **4**, which indicates to terminal A that the modem is ready to transmit data.
- Terminal A serializes the data to be transmitted (through the serdes) and transmits the data one bit at a time (synchronized by the transmit clock) onto the 'transmitted data' line **6** to the modem.
- The modem modulates the carrier signal with the data and transmits it to the modem B **5**.
- Modem B demodulates the data from the carrier signal and sends it to terminal B on the 'received data' line **12**.
- Terminal B deserializes the data (through the serdes) using the receive clock signals (on the 'receiver signal element timing' line) **11** from the modem.
- After terminal A completes its transmission, it deactivates the 'request to send' line **3**, which causes the modem to turn off the carrier and deactivate the 'clear to send' line **4**.
- Terminal A and modem A now become receivers and wait for a response from terminal B, indicating that all data has reached terminal B. Modem A begins an echo delay (50 to 150 milliseconds) to ensure that all echoes on the line have diminished before it begins receiving. An echo is a reflection of the transmitted signal. If the transmitting modem changed to receive too soon, it could receive a reflection (echo) of the signal it just transmitted.
- Modem B deactivates the 'received line signal detector' line **10** and, if necessary, deactivates the receive clock signals on the 'receiver signal element timing, line **11**.
- Terminal B now becomes the transmitter to respond to the request from terminal A. To transmit data, terminal B activates the 'request to send' line **13**, which causes modem B to transmit a carrier to modem A.
- Modem B begins a delay that is longer than the echo delay at modem A before turning on the 'clear to send' line. The longer delay (called request-to-send to clear-to-send delay) ensures that modem A is ready to receive when terminal B begins transmitting data. After the delay, modem B activates the 'clear to send' line **14** to indicate that terminal B can begin transmitting its response.
- After the echo delay at modem A, modem A senses the carrier from modem B (the carrier was activated in step 13 when terminal B activated the 'request to send' line) and activates the 'received line signal detector' line **7** to terminal A.
- Modem A and terminal A are now ready to receive the response from terminal B. Remember, the response was not transmitted until after the request-to-send to clear-to-send delay at modem B (step 14).

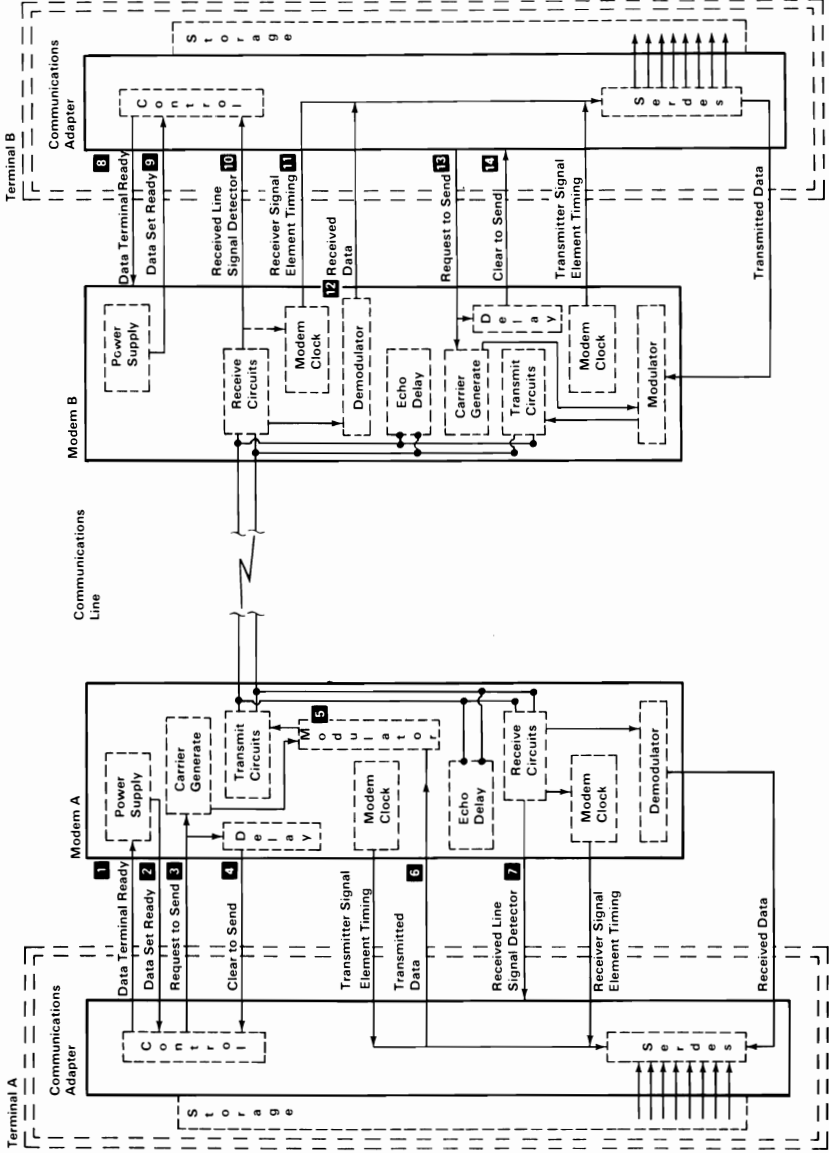

SECTION 8

Establishing a Link on a Nonswitched Multipoint Line

- The control station serializes the address for the tributary or secondary station (AA) and sends its address to the modem on the 'transmitted data' line **2**.
- Since the 'request to send' line and, therefore, the modem carrier, is active continuously **1**, the modem immediately modulates the carrier with the address, and, thus, the address is transmitted to all modems on the line.
- All tributary modems, including the modem for station A, demodulate the address and send it to their terminals on the 'received data' line **5**.
- Only station A responds to the address; the other stations ignore the address and continue monitoring their 'received data' line. To respond to the poll, station A activates its 'request to send' line **6** which causes the modem to begin transmitting a carrier signal.
- The control station's modem receives the carrier and activates the 'received line signal detector' line **3** and the 'receiver signal element timing' line **4** (to send clock signals to the control station). Some modems activate the clock signals as soon as they are powered on.
- After a short delay to allow the control station modem to receive the carrier, the tributary modem activates the 'clear to send' line **7**.
- When station A detects the active 'clear to send' line, it transmits its response. (For this example, assume that station A has no data to send; therefore, it transmits an EOT **8**.)
- After transmitting the EOT, station A deactivates the 'request to send' line **6**. This causes the modem to deactivate the carrier and the 'clear to send' line **7**.
- When the modem at the control station (host) detects the absence of the carrier, it deactivates the 'received line signal detector' line **3**.
- Tributary station A is now in receive mode waiting for the next poll or select transmission from the control station.

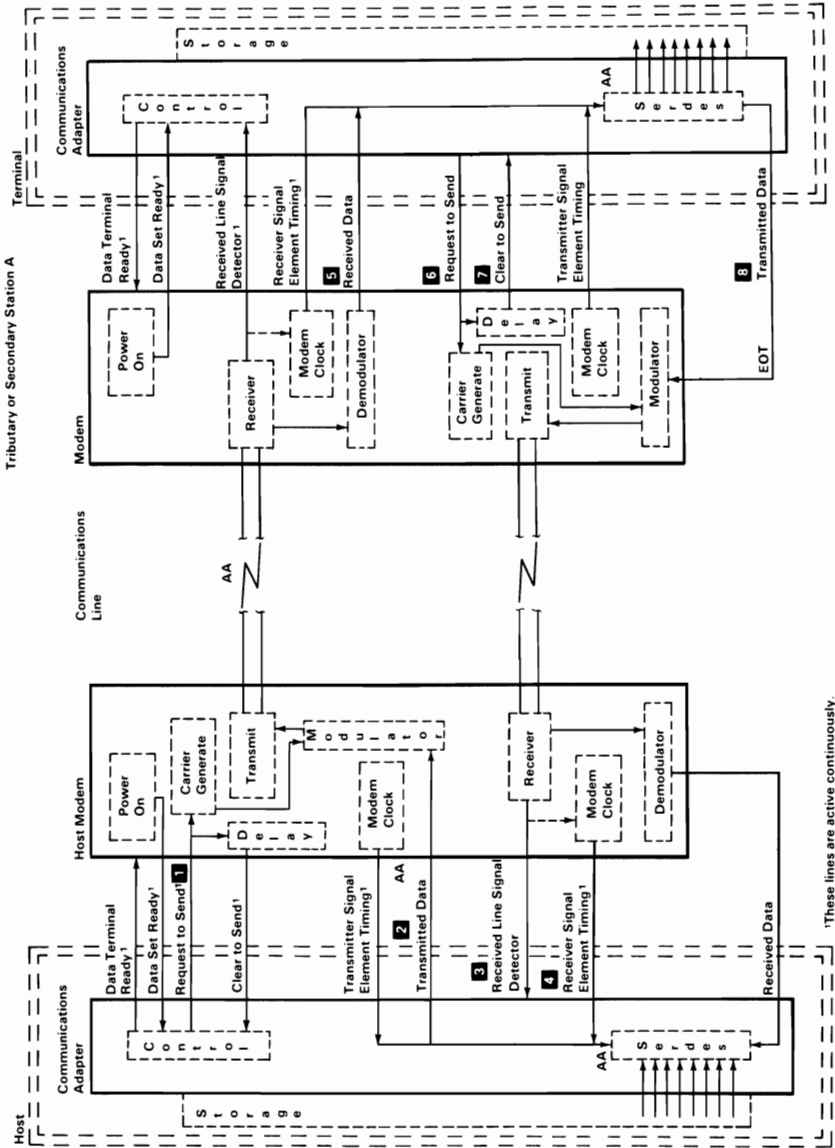

¹These lines are active continuously.

Establishing a Link on a Switched Point-To-Point Line

1. Terminal A is in communications mode; therefore, the 'data terminal ready' line **1** is active. Terminal B is in communication mode waiting for a call from terminal A.
 2. When the terminal A operator lifts the telephone handset, the 'switch hook' line from the coupler is activated **3**.
 3. Modem A detects the 'switch hook' line and activates the 'off hook' line **4**, which causes the coupler to connect the telephone set to the line and activate the 'coupler cut-through' line **5** to the modem.
 4. Modem A activates the 'data modem ready' line **6** to the coupler (the 'data modem ready' line is on continuously in some modems).
 5. The terminal A operator sets the exclusion key or talk/data switch to the talk position to connect the handset to the communications line. The operator then dials the terminal B number.
 6. When the telephone at terminal B rings, the coupler activates the 'ring indicate' line to modem B **10**. Modem B indicates that the 'ring indicate' line was activated by activating the 'ring indicator' line **13** to terminal B.
 7. Terminal B activates the 'data terminal ready' line to modem B **12**, which activates the autoanswer circuits in modem B. (The 'data terminal ready' line might already be active in some terminals.)
 8. The autoanswer circuits in modem B activate the 'off hook' line to the coupler **8**.
 9. The coupler connects modem B to the communications line through the 'data tip' and 'data ring' lines **11** and activates the 'coupler cut-through' line **9** to the modem. Modem B then transmits an answer tone to terminal A.
 10. The terminal A operator hears the tone and sets the exclusion key or talk/data switch to the data position (or performs an equivalent operation) to connect modem A to the communications line through the 'data tip' and 'data ring' lines **7**.
 11. The coupler at terminal A deactivates the 'switch hook' line **3**. This causes modem A to activate the 'data set ready' line **2** indicating to terminal A that the modem is connected to the communications line.
- The sequence of the remaining steps to establish the data link is the same as the sequence required on a nonswitched point-to-point line. When the terminals have completed their transmission, they both deactivate the 'data terminal ready' line to disconnect the modems from the line.

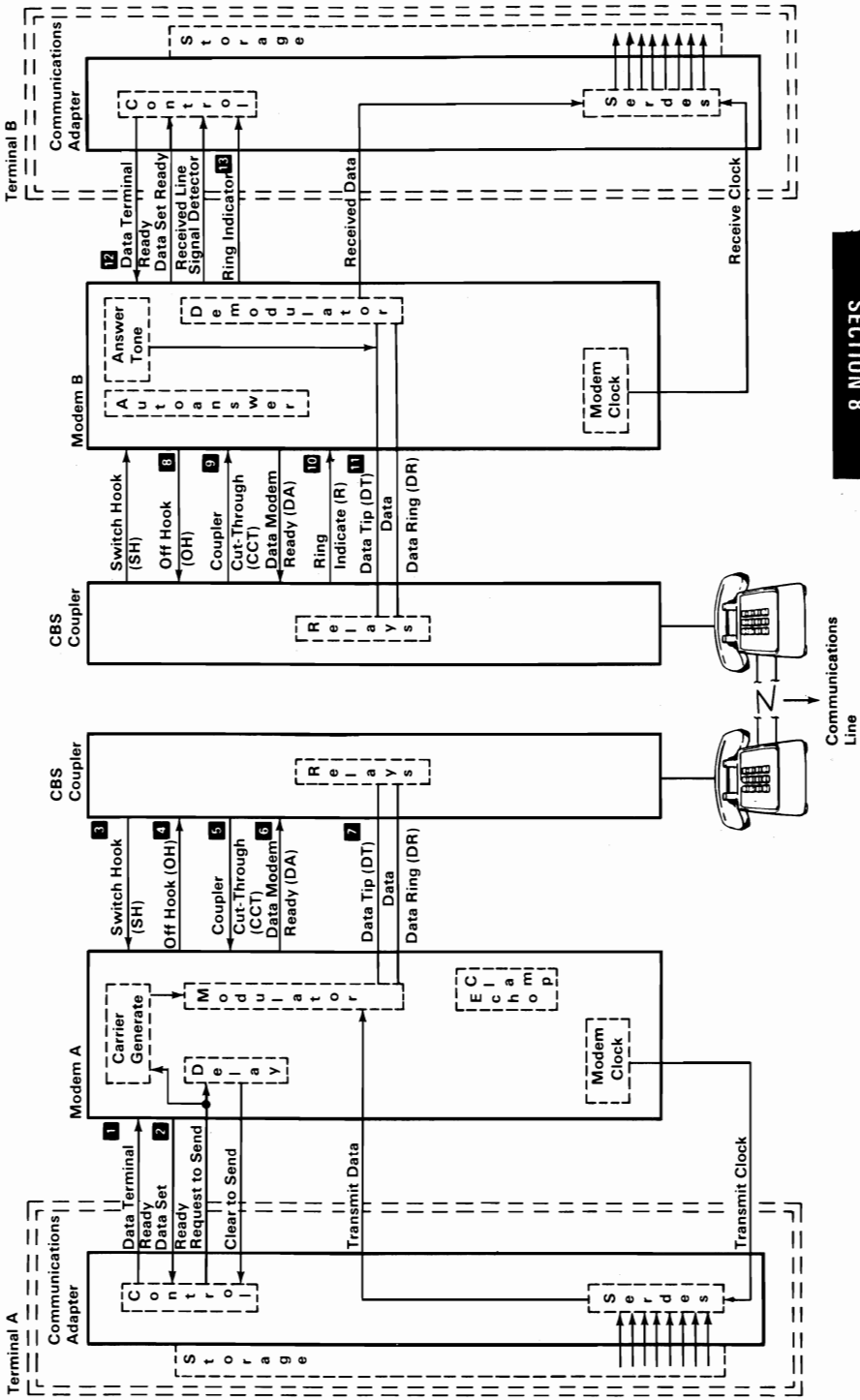

Notes:



SECTION 9. IBM PERSONAL COMPUTER COMPATIBILITY

Contents

Hardware Considerations	9-3
System Board	9-3
20Mb Fixed Disk Drive	9-4
High Capacity Diskette Drive	9-4
Adapters	9-4
Keyboard	9-4
The IBM Personal Computer AT Does Not Support	9-5
Application Guidelines	9-5
High-Level Language Considerations	9-5
Assembler Language Programming Considerations	9-6
Multi-tasking Provisions	9-11
Interfaces	9-11
Classes	9-13
Timeouts	9-15
SYS REQ Key	9-15
Subsystem Structure	9-15
Subsystem Startup and Lockout	9-16
SYS REQ Key Functions	9-17
SYS Key Interfaces	9-18
Copy Protection	9-22
Bypassing BIOS	9-22
Diskette Drive Differences	9-22
Write Current	9-23
Machine-Sensitive Code	9-23

Notes:

This section shows the differences between the IBM Personal Computer AT and the rest of the IBM Personal Computer family. It also contains information necessary to design hardware and programs that will be compatible with all IBM Personal Computers.

Hardware Considerations

In order to design compatible hardware or programs, hardware differences between the IBM Personal Computers must be considered. The following are hardware features of the IBM Personal Computer AT that are not supported by the rest of the IBM Personal Computer Family.

System Board

The IBM Personal Computer AT system board uses an Intel 80286 microprocessor which is generally compatible with the Intel 8088 microprocessor used in the rest of the IBM Personal Computers. Programming considerations because of the faster processing capability of the 80286 are discussed later in "Application Guidelines."

The system board expansion slots in the IBM Personal Computer AT have a 36-pin connector in addition to the 62-pin connector. Adapters designed to make use of the 36-pin connector are not compatible with the rest of the IBM Personal Computers.

On the I/O channel:

- The system clock signal should only be used for synchronization and not for applications requiring a fixed frequency.
- The 14.31818 MHz oscillator is not synchronous with the system clock.
- 'ALE' is activated during DMA cycles.

- The 'I/O write' signal is not active during refresh cycles.
- Pin B04 supports IRQ 9.

20Mb Fixed Disk Drive

The fixed disk drive used in the IBM Personal Computer AT can store up to 20Mb of data. Reading from and writing to this drive is initiated in the same way as with the Personal Computer XT; however, the IBM Personal Computer AT Fixed Disk and Diskette Drive Adapter may be addressed from different BIOS locations.

High Capacity Diskette Drive

This diskette drive is capable of reading and writing diskettes in 160/180Kb, 320/360Kb, and 1.2Mb mode. However, if a diskette, formatted in either the 160/180Kb or 320/360Kb mode is written on by this diskette drive, that information may only be read by a high capacity diskette drive.

Note: Diskettes, designed for use in this drive, in the 1.2Mb mode may not be used in either a 160/180Kb or a 320/360Kb diskette drive.

Adapters

The IBM Personal Computer AT 128KB Memory Expansion Option, the IBM Personal Computer AT 512KB Memory Expansion Option, the IBM Personal Computer AT Prototype Adapter, and the IBM Personal Computer AT Fixed Disk and Diskette Drive Adapter use the additional 36 pin system board expansion slot and are not compatible with the rest of the IBM Personal Computer Family.

Keyboard

The IBM Personal Computer AT Keyboard is an 84-key unit that can perform all functions of the other IBM Personal Computer keyboards, but is not plug-compatible with any of the other keyboards.

The IBM Personal Computer AT Does Not Support

- Expansion Unit
- IBM Asynchronous Communications Adapter
- IBM 64/256KB Memory Expansion Adapter
- IBM Printer Adapter
- Other keyboards

Application Guidelines

The following information should be used to develop application programs for the IBM Personal Computer family.

High-Level Language Considerations

The IBM-supported languages of BASIC, FORTRAN, COBAL, Pascal, and APL are the best choices for writing compatible programs.

If a program uses specific features of the hardware, that program may not be compatible with all IBM Personal Computers. Specifically, the use of assembler language subroutines or hardware-specific commands (In, Out, Peek, Poke, ...) must follow the assembler language rules (see "Assembler Language Programming").

Any program that requires precise timing information should obtain it through a DOS or language interface; for example, TIME\$ in BASIC. If greater precision is required, the assembler techniques in "Assembly Language Programming" are available. The use of programming loops may prevent a program from being compatible with other IBM Personal Computers.

Assembler Language Programming Considerations

The following OP codes work differently on the IBM Personal Computer AT than they do on other IBM Personal Computers.

- If the system microprocessor executes a POPF instruction in either the real or the virtual address mode with $CPL \leq IOPL$, then a pending maskable interrupt (the INTR pin active) may be improperly recognized after executing the POPF instruction even if maskable interrupts were disabled before the POPF instruction and the value popped had $IF=0$. If the interrupt is improperly recognized, the interrupt is still correctly executed. This errata has no effect when interrupts are enabled in either real or virtual address mode. This errata has no effect in the virtual address mode when $CPL > IOPL$.

The POPF instruction may be simulated with the following code macro:

```

POPFF      Macro      ;use POPFF instead of POPF
                ;simulate popping flags
                ;using IRET

EB 01      JMP $+3    ;jump around IRET

CF         IRET      ;POP CS, IP, flags

0E         PUSH CS    ;push CS

E8 FB FF   CALL $-2  ;CALL within segment
                ;program will continue here
    
```

- **PUSH SP** pushes the current stack pointer. The microprocessor used in the IBM Personal Computer and the IBM Personal Computer XT pushes the new stack pointer.
- Single step interrupt (when $TF=1$) does not occur on the interrupt instruction (OP code hex CC,CD). The microprocessor in the IBM Personal Computer and the IBM Personal Computer XT does interrupt on the INT instruction.
- The divide error exception (interrupt 0) pushes the CS:IP of the instruction, causing the exception. The IBM Personal Computer and the IBM Personal Computer XT push the CS:IP following the instruction, causing the exception.
- Shift counts are masked to 5 bits. Shift counts greater than 31 are treated mod 32, that is, a shift count of 36 shifts the operand 4 places.

Assembler language programs should perform all I/O operations through ROM BIOS or DOS function calls.

- Program interrupts are used for access to these functions. This practice removes the absolute addressing from the program. Only the interrupt number is required.
- The math coprocessor detects six different exception conditions that can occur during instruction execution. If the appropriate exception mask within the coprocessor is not set, the coprocessor sets its error signal. This error signal generates a hardware interrupt (interrupt 13) and causes the 'BUSY' signal to the coprocessor to be held in the busy state. The 'BUSY' signal may be cleared by an 8-bit I/O Write command to address hex F0 with D0 through D7 equal to 0.

The power-on-self test code in the system ROM enables hardware interrupt 13 and sets up its vector to point to a routine in ROM. The ROM routine clears the 'BUSY' signal's latch and then transfers control to the address pointed to by the NMI interrupt vector. This allows code written for any IBM Personal Computer to work on an IBM Personal Computer AT. The NMI interrupt handler should read the coprocessor's status to determine if the NMI was caused by

the coprocessor. If the interrupt was not generated by the coprocessor, control should be passed to the original NMI interrupt handler.

- Back to back I/O commands to the same I/O ports will not permit enough recovery time for I/O chips. To insure enough time, a `JMP SHORT $+2` must be inserted between IN/OUT instructions to the same I/O chip.

Note: `MOV AL,AH` type instruction does not allow enough recovery time. An example of the correct procedure follows:

```
OUT  IO__ADD,AL
```

```
JMP  SHORT $+2
```

```
MOV  AL,AH
```

```
OUT  IO__ADD,AL
```

- In the IBM Personal Computer AT IRQ 9 is redirected to INT hex 0A (hardware IRQ 2). This insures that hardware designed to use IRQ 2 will operate in the IBM Personal Computer AT.
- The system can mask hardware sensitivity. New devices can change the ROM BIOS to accept the same programming interface on the new device.
- In cases where BIOS provides parameter tables, such as for video or diskette, a program may substitute new parameter values by building a new copy of the table and changing the vector to point to that table. However, the program should copy the current table, using the current vector, and then modify those locations in the table that need to be changed. In this way, the program will not inadvertently change any values that should be left the same.
- `Disk_Base` consists of 11 parameters required for diskette operation. They are pointed at by the data variable, `Disk_Pointer`, at absolute address 0:78. It is strongly recommended that the values supplied in ROM be used. If it

becomes necessary to modify any of the parameters, build another parameter block and modify the address in Disk-Pointer to point to the new block. The parameters were established to operate both the High Capacity Diskette Drive and the Double Sided Diskette Drive. Three of the parameters in this table are under control of BIOS in the following situations. The Gap Length Parameter is no longer retrieved from the parameter block. Gap length used during diskette read, write, and verify operations is derived from within diskette BIOS. Gap length for format operations is still obtained from the parameter block. Special considerations are required for formatting operations. See the prologue of Diskette BIOS for the required details. If a parameter block contains a head settle time parameter value of 0 milliseconds, and a write operation is being performed, at least 15 milliseconds of head settle time will be enforced for a High Capacity Diskette Drive and 20 milliseconds will be enforced for a Double Sided Diskette Drive. If a parameter block contains a motor start wait parameter of less than 1 second for a write or format operation or 625 milliseconds for a read or verify operation, Diskette BIOS will enforce those times listed above.

- The following procedure is used to determine the type of media inserted in the High Capacity Diskette Drive:
 1. Read Track 0, Head 0, Sector 1 to allow diskette BIOS to establish the media/drive combination. If this is successful, continue with the next step.
 2. Read Track 0, Sector 15. If an error occurs, a double sided diskette is in the drive. If a successful read occurs, a high capacity diskette is in the drive.
 3. If Step 1 fails, issue the reset function (AH=0) to diskette BIOS and retry. If a successful read cannot be done, the media needs to be formatted or is defective.

ROM BIOS and DOS do not provide for all functions. The following are the allowable I/O operations with which IBM will maintain compatibility in future systems.

- Control of the sound using port hex 61, and the sound channel of the timer/counter. A program can control timer/counter channels 0 and 2, ports hex 40, 42, and 43. A program must not change the value in port hex 41, because this port controls the dynamic-memory refresh. Channel 0 provides the time-of-day interrupt, and can also be used for timing short intervals. Channel 2 of the timer/counter is the output for the speaker and cassette ports. This channel may also be used for timing short intervals, although it cannot interrupt at the end of the period.

- Control of the Game Control Adapter, port hex 201

Note: Programs should use the timer for delay on the paddle input rather than a program loop.

- Interrupt Mask Register (IMR), port hex 21, can be used to selectively mask and unmask the hardware features.

The following information pertains to absolute memory locations.

- Interrupt Vectors (hex 0)--A program may change these to point at different processing routines. When an interrupt vector is modified, the original value should be retained. If the interrupt, either hardware or program, is not directed toward this device handler, the request should be passed to the next item in the list.
- Video Display Buffers (hex B0000 and B8000)-- For each mode of operation defined in the video display BIOS, the memory map will remain the same. For example, the bit map for the 320 x 200 medium-resolution graphics mode of the Color/Graphics Monitor adapter will be retained on any future adapter that supports that mode. If the bit map is modified, a different mode number will be used.
- ROM BIOS Data Area (40:0)--Any variables in this area will retain their current definition, whenever it is reasonable to do so. IBM may use these data areas for other purposes when the variable no longer has meaning in the system. In general, ROM BIOS data variables should be read or modified through BIOS calls whenever possible, and not with direct access to the variable.

A program that requires timing information should use either the time-of-day clock or the timing channels of the timer/counter. The input frequency to the timer will be maintained at 1.19 MHz, providing a constant time reference. Program loops should be avoided.

Programs that use copy protection schemes should use the ROM BIOS diskette calls to read and verify the diskette and should not be timer dependent. Any method can be used to create the diskette, although manufacturing capability should be considered. The verifying program can look at the diskette controller's status bytes in the ROM BIOS data area for additional information about embedded errors. More information about copy protection may be found under 'Copy Protection' later in this section.

Any DOS program must be relocatable and insensitive to the size of DOS or its own load addresses. A program's memory requirement should be identified and contiguous with the load module. A program should not assume that all of memory is available to it.

Multi-tasking Provisions

The IBM Personal Computer AT BIOS contains a feature to assist multi-tasking implementation. "Hooks" are provided for a multi-tasking dispatcher. Whenever a busy (wait) loop occurs in the BIOS, a hook is provided for the system to break out of the loop. Also, whenever an interrupt is serviced by the BIOS, which causes a corresponding wait loop to be exited, another hook is provided for the system.

Thus a system may be written which employs the bulk of the device driver code. The following is valid only in the microprocessor's real address mode. Several steps must be taken by the system code in order to allow this support. First, the system is responsible for the serialization of access to the device driver. The BIOS code is not reentrant. Second, the system is responsible for matching corresponding wait and post calls.

Interfaces

There are four interfaces to be used by the multi-tasking dispatcher:

Startup

The first thing to be done is for the startup code to hook interrupt hex 15. The dispatcher is responsible to check for function codes AH = hex 90 and 91. The "Wait" and "Post" sections describe these codes. The dispatcher must pass all other functions through to the previous user of interrupt hex 15. This can be done via a JMP or a CALL. If the function code is hex 90 or 91, then the dispatcher should do the appropriate processing and return via the IRET instruction.

Serialization

It is up to the multi-tasking system to insure that the device driver code is used in a serial fashion. Multiple entries into the code can result in very serious errors.

Wait (Busy)

Whenever the BIOS is about to enter a busy loop, it first issues an interrupt 15 with a function code of hex 90 in AH. This signals a WAIT condition. At this point, the dispatcher should save the task status and dispatch another task. This allows overlapped execution of tasks when the hardware is busy. The following is an outline of the code which has been added to the BIOS to implement this function.

EXAMPLE DEVICE BUSY LOOP

DO UNTIL

MOV AX, hex 90XX ;WAIT code in AH and

```

;TYPE code in AL
INT hex 15 ;issue call
JC TIMEOUT ;optional: for timeout or
;if carry is set, timeout
;occurred
NORMAL TIMEOUT LOGIC ;normal timeout

```

UNTIL INTERRUPT COMPLETE FLAG IS SET

POST (Interrupt)

Whenever the BIOS has set an interrupt flag for a corresponding busy loop, an interrupt 15 occurs with a function code hex 91 in AH. This signals a POST condition. At this point, the dispatcher should set the task status to "ready to run" and return to the interrupt routine. The following BIOS has been added to code to implement this function.

INTERRUPT PROCESSING

SET INTERRUPT COMPLETE FLAG FOR BUSY LOOP

```

MOV AX,hex 91XX ; post code AH and
; type code AL
INT hex 15 ; issue call

```

Classes

The following types of wait loops are supported:

- The class for 0->7Fh is serially reusable. This means that for the devices that use these codes, access to the BIOS must be restricted to only one task at a time.
- The class for 80h->BFh is reentrant. There is no restriction on the number of tasks which may access the device.
- The class for C0h->FFh is non-interrupt. There is no corresponding interrupt for the wait loop. Therefore, it is the responsibility of the dispatcher to determine what satisfies this condition to exit the loop.

Function Code Classes

type code (AL)	Description
00h->7Fh	serially reusable devices; operating system must serialize access
80h->0BFh	reentrant devices; ES:BX is used to distinguish different calls (multiple I/O calls are allowed simultaneously)
0C0h->0FFh	wait only calls; there is no complementary "POST" for these waits--these are timeout only. Times are function number dependent.

Function Code Assignments

The following are specific assignments for the IBM Personal Computer AT BIOS. They are grouped according to the classes described under "Function Code Classes".

Type Code (AL)	Timeout	Description
00H	yes (6 sec)	IBM Personal Computer AT fixed disk

01H	yes (2 sec)	IBM Personal Computer AT diskette
02H	no	IBM Personal Computer AT keyboard
0FDH	yes (1 sec-write)	diskette motor start
--	(625 msec-read)	--
0FEH	yes (?? sec)	printer

The asynchronous support has been omitted. The IBM Personal Computer AT Serial/Parallel Adapter will generate interrupts, but BIOS does not support it in the interrupt mode. Therefore, the support should be included in the multi-tasking system code if that device is to be supported.

Timeouts

In order to support timeouts properly, it is necessary for the multi-tasking dispatcher to be aware of time. If a device enters a busy loop, it generally should remain there for a specific amount of time before indicating an error. The dispatcher should return to the BIOS wait loop with the carry bit set if a timeout occurred.

SYS REQ Key

The following describes the use of the SYS REQ key in a multi-tasking environment. It assumes that tasks used are cooperative in some manner. The system must employ a task monitor to allow the user to select various tasks. This selection may be for starting tasks, terminating tasks, supplying input to tasks from the keyboard, or any other function that requires user input.

Subsystem Structure

The following figure shows three subsystems which have multiple tasks. They are arranged in order of hierarchy. Tasks in subsystem B can only run when Task "Other" A is active in subsystem A and tasks in subsystem C can only run when Task "Other" B is active in subsystem B.

Task 1A	Task 2A	Task 3A	Task "Other" A		
Subsystem B Inhibited			Task 1B	Task 2B	Task B
			Subsystem C Inhibited		"Other " Task 1C Task 2C

Multiple Task Subsystems

The order in which subsystems were installed (loaded into main storage) determines their priority. The first one installed is higher on the hierarchy. An inhibit mechanism provided at startup time enforces the hierarchy. As a subsystem starts, it broadcasts to the rest of the subsystems, previously installed, that it is starting and at the same time, provides the address of a lock. This lock must be set (incremented) by subsystems higher in the hierarchy whenever they wish to run one of their own tasks. This flag must be set for each subsystem lower on the hierarchy, for example, when subsystem A is about to start Task 2A, the dispatcher must set subsystem B inhibit and subsystem C inhibit.

Subsystem Startup and Lockout

In order for multiple subsystems to cooperate, there must be communication between subsystems when a subsystem is loaded into storage and initialized.

The subsystem being loaded tells the previously loaded subsystems that it is being loaded and broadcasts the address of its synchronization lock. Higher priority subsystems use this lock to exclude the new subsystem from accessing any system resources (DOS, interrupts, etc.).

After a subsystem is loaded, it must "listen" for any subsystems that may be loaded later so that it can lock them out when it is running. The following describes the code sequence for startup.

Startup Interface

```
MOV AX,SEG SYSLOCK      ;segment of lock
MOV ES,AX                --
MOV BX,OFFSET SYSLOCK   ;offset of lock
MOV AX,2000H             ;AH=20H, AL=0
INT 15H                  --
```

Lockout Interface

The register ES:BX points to a byte which initially contains a value of 0. Whenever a higher priority subsystem wishes to run, it increments the lock. When it completes running, it decrements the lock. This allows proper synchronization of resources and subsystems.

SYS REQ Key Functions

During initialization, the subsystem also needs to connect to the SYS REQ key function. It is necessary for the SYS key code to be included in each subsystem. This startup section determines if the SYS support is already loaded and loads the support if necessary.

The SYS functions provide a means for the subsystem's main screen or menu to be displayed. If the subsystem requires no user action, then these functions need not be provided.

SYS Key Modes

There are two SYS key modes: multiple press and super shift.

Multiple Press Mode: This mode allows the user to sequence through subsystems. Subsystems are displayed in the reverse order of their installation.

Super Shift Mode: This mode allows the user direct access to any subsystem regardless of the priority. The user activates this mode by holding the SYS key pressed and pressing another key which designates another subsystem.

Multiple Key Sequence

If a subsystem is to be used on the IBM Personal Computer and the IBM Personal Computer XT, a multiple key sequence must be used to access the SYS key functions.

SYS Key Interfaces

There are four interfaces needed by the SYS code to support a subsystem: startup, activation, cancellation, and completion. The subsystem activates two of these: startup and completion. The SYS code in conjunction with user input activates the other two.

The following is a description, in tabular form, of the states, transitions, and actions needed to implement the SYS REQ functions.

Subsystem Entry Points

subsys A	code A
subsys B	code B
subsys C	code C

Entry Points

subsystems

current subsystem #

num

cur

State/Transition Table

Current State	Input	Next State	Action
Idle	SYS REQ	Active	activate subsys 'cur'
	SYS code	Active Super	activate subsys 'code'
	Startup	Idle	increment 'num' set 'cur' to 'num' insert entry point and code
Active	SYS REQ	Active	cancel subsys 'cur' decrement 'cur' activate subsys 'cur'
	Completion 'cur'	Idle	set 'cur' to 'num'
	Startup	Active	increment 'num' insert entry point and code
	SYS code	Active Super	activate subsys 'code'
Active Super	Completion 'cur'	Idle	set 'cur' to 'num'
	Startup	Active	increment 'num' insert entry point and code

Startup

At startup, a call is issued to determine if the SYS REQ key support is already loaded and to initialize the support for the new subsystem.

The parameters for the startup routine are the address of the entry point and the function code (direct-access mode). If the operation was successful, the carry flag is set.

The following shows the calling sequence.

```
MOV AX,SEG entry__point      ;address for SYS to call
MOV ES,AX                    ;
MOV BX,OFFSET entry__point  ;
MOV CX,XXXX                  ;super shift mode code
MOV AX,2010H                 ;AH=20H, AL=10
INT 15H                      ;
```

If the carry flag is not set, the initialization code needs to hook the vector for interrupt 15H, save the previous address, and reissue the initialization call.

Activation

This is a signal from the SYS REQ processing module that a subsystem's monitor is to be activated.

This entry into the subsystem dispatcher signals that the monitor task should be activated. It should be treated as a signal to set a flag for the subsystem rather than an opportunity to gain control of the system asynchronously as it may not be a proper time for the subsystem to run. The subsystem may have to wait until a higher priority subsystem allows it to have control before the subsystem's monitor gets control. The subsystem entry point is CALLED with the AH register set to 0.

Cancellation

This signal from the SYS REQ processing module tells the subsystem monitor to ignore the previous activation signal and take the necessary action to return to its previous state.

This entry into the subsystem dispatcher signals that the monitor task should be deactivated. The subsystem may not have control of the system. It is necessary for the subsystem to note that a cancellation has occurred and to wait until it has a valid opportunity to run through its dispatcher code in a normal fashion. The subsystem entry point is CALLED with the AH register set to 1.

Completion

The following call signals completion. Completion constitutes any action taken by the user when the subsystem's menu is displayed.

The completion call causes the activation pointer to be reset to the lowest priority subsystem. All lower priority subsystems also receive a cancellation notification.

```
MOV AX,SEG entry__point    ;address for SYS to call
MOV ES,AX                  ;
MOV BX,OFFSET entry__point ;ES:BX must contain the same
                             ;values as the startup call
MOV AX,2011H               ;AH=20H, AL=11H
INT 15H                     ;
```

Copy Protection

Some modes of copy protection will not work on the IBM Personal Computer AT due to the following conditions:

- Bypassing BIOS
- Diskette drive differences
- Write current differences

Bypassing BIOS

Copy protection, which depends on the following will not work on the IBM Personal Computer AT:

Track Density: The High Capacity Diskette Drive records tracks at a density of 96TPI. This drive has to double step in the 48TPI mode, which is performed by BIOS.

Data Transfer Rate: BIOS selects the proper data transfer rate for the media being used.

Disk__Base: Copy protection, which creates its own disk__base will not work on the High Capacity Diskette Drive.

Diskette Drive Differences

Copy protection, which depends on the following will not work on the High Capacity Diskette Drive:

Rotational Speed: Copy protection using the time between two events on a diskette will not work on the High Capacity Diskette Drive.

Access Time: Diskette BIOS must set the track to track access time for the different types of media used on the IBM Personal Computer AT.

Head Geometry: See 'High Capacity Diskette Drive' earlier in this section.

Diskette Change Signal: Copy protection may not be able to reset this signal.

Write Current

The IBM Personal Computer AT Fixed Disk and Diskette Drive Adapter selects the proper write current for the media being used.

Machine-Sensitive Code

Programs may program for machine specific features, but they must test for specific machine type. Location hex 0FFFF:0E contains the machine identification:

Hex	Machine Identification
0FF	IBM Personal Computer
0FE	IBM Personal Computer XT
0FD	IBM PCjr
0FC	IBM Personal Computer AT

Machine Identification Code

IBM will define methods for uniquely determining the specific machine type or I/O feature for any new device.

Notes:



Glossary

μ. Prefix micro; 0.000 001.

μs. Microsecond; 0.000 001 second.

A. Ampere.

ac. Alternating current.

accumulator. A register in which the result of an operation is formed.

active high. Designates a signal that has to go high to produce an effect. Synonymous with positive true.

active low. Designates a signal that has to go low to produce an effect. Synonymous with negative true.

adapter. An auxiliary device or unit used to extend the operation of another system.

address bus. One or more conductors used to carry the binary-coded address from the processor throughout the rest of the system.

algorithm. A finite set of well-defined rules for the solution of a problem in a finite number of steps.

all points addressable (APA). A mode in which all points of a displayable image can be controlled by the user.

alphameric. Synonym for alphanumeric.

alphanumeric (A/N). Pertaining to a character set that contains letters, digits, and usually other characters, such as punctuation marks. Synonymous with alphameric.

alternating current (ac). A current that periodically reverses its direction of flow.

American National Standard Code for Information Exchange (ASCII). The standard code, using a coded character set consisting of 7-bit coded characters (8 bits including parity check), used for information exchange between data processing systems, data communication systems, and associated equipment. The ASCII set consists of control characters and graphic characters.

ampere (A). The basic unit of electric current.

A/N. Alphanumeric

analog. (1) Pertaining to data in the form of continuously variable physical quantities. (2) Contrast with digital.

AND. A logic operator having the property that if P is a statement, Q is a statement, R is a statement,...., then the AND of P, Q, R,...is true if all statements are true, false if any statement is false.

AND gate. A logic gate in which the output is 1 only if all inputs are 1.

AND operation. The boolean operation whose result has the boolean value 1, if and only if, each operand has the boolean value 1. Synonymous with conjunction.

APA. All points addressable.

ASCII. American National Standard Code for Information Exchange.

assemble. To translate a program expressed in an assembler language into a computer language.

assembler. A computer program used to assemble.

assembler language. A computer-oriented language whose instructions are usually in one-to-one correspondence with computer instructions.

asynchronous transmission. (1) Transmission in which the time of occurrence of the start of each character, or block of characters, is arbitrary; once started, the time of occurrence of each signal representing a bit within a character, or block, has the same relationship to significant instants of a fixed time frame. (2) Transmission in which each information character is individually transmitted (usually timed by the use of start elements and stop elements).

audio frequencies. Frequencies that can be heard by the human ear (approximately 15 hertz to 20 000 hertz).

auxiliary storage. (1) A storage device that is not main storage. (2) Data storage other than main storage; for example, storage on magnetic disk. (3) Contrast with main storage.

BASIC. Beginner's all-purpose symbolic instruction code.

basic input/output system (BIOS). The feature of the IBM Personal Computer that provides the level control of the major I/O devices, and relieves the programmer from concern about hardware device characteristics.

baud. (1) A unit of signaling speed equal to the number of discrete conditions or signal events per second. For example, one baud equals one bit per second in a train of binary signals, one-half dot cycle per second in Morse code, and one 3-bit value per second in a train of signals each of which can assume one of eight different states. (2) In asynchronous transmission, the unit of modulation rate corresponding to one unit of interval per second; that is, if the duration of the unit interval is 20 milliseconds, the modulation rate is 50 baud.

BCC. Block-check character.

beginner's all-purpose symbolic instruction code (BASIC). A programming language with a small repertoire of commands and a simple syntax, primarily designed for numeric applications.

binary. (1) Pertaining to a selection, choice, or condition that has two possible values or states. (2) Pertaining to a fixed radix numeration system having a radix of 2.

binary digit. (1) In binary notation, either of the characters 0 or 1. (2) Synonymous with bit.

binary notation. Any notation that uses two different characters, usually the binary digits 0 and 1.

binary synchronous communications (BSC). A uniform procedure, using a standardized set of control characters and control character sequences for synchronous transmission of binary-coded data between stations.

BIOS. Basic input/output system.

bit. Synonym for binary digit

bits per second (bps). A unit of measurement representing the number of discrete binary digits transmitted by a device in one second.

block. (1) A string of records, a string of words, or a character string formed for technical or logic reasons to be treated as an entity. (2) A set of things, such as words, characters, or digits, treated as a unit.

block-check character (BCC). In cyclic redundancy checking, a character that is transmitted by the sender after each message block and is compared with a block-check character computed by the receiver to determine if the transmission was successful.

boolean operation. (1) Any operation in which each of the operands and the result take one of two values. (2) An operation that follows the rules of boolean algebra.

bootstrap. A technique or device designed to bring itself into a desired state by means of its own action; for example, a machine routine whose first few instructions are sufficient to bring the rest of itself into the computer from an input device.

bps. Bits per second.

BSC. Binary synchronous communications.

buffer. (1) An area of storage that is temporarily reserved for use in performing an input/output operation, into which data is read or from which data is written. Synonymous with I/O area. (2) A portion of storage for temporarily holding input or output data.

bus. One or more conductors used for transmitting signals or power.

byte. (1) A sequence of eight adjacent binary digits that are operated upon as a unit. (2) A binary character operated upon as a unit. (3) The representation of a character.

C. Celsius.

capacitor. An electronic circuit component that stores an electric charge.

CAS. Column address strobe.

cathode ray tube (CRT). A vacuum tube in which a stream of electrons is projected onto a fluorescent screen producing a luminous spot. The location of the spot can be controlled.

cathode ray tube display (CRT display). (1) A CRT used for displaying data. For example, the electron beam can be controlled to form alphanumeric data by use of a dot matrix. (2) The data display produced by the device as in (1).

CCITT. International Telegraph and Telephone Consultative Committee.

Celsius (C). A temperature scale. Contrast with Fahrenheit (F).

central processing unit (CPU). Term for processing unit.

channel. A path along which signals can be sent; for example, data channel, output channel.

character generator. (1) In computer graphics, a functional unit that converts the coded representation of a graphic character into the shape of the character for display. (2) In word processing, the means within equipment for generating visual characters or symbols from coded data.

character set. (1) A finite set of different characters upon which agreement has been reached and that is considered complete for some purpose. (2) A set of unique representations called characters. (3) A defined collection of characters.

characters per second (cps). A standard unit of measurement for the speed at which a printer prints.

check key. A group of characters, derived from and appended to a data item, that can be used to detect errors in the data item during processing.

closed circuit. A continuous unbroken circuit; that is, one in which current can flow. Contrast with open circuit.

CMOS. Complementary metal oxide semiconductor.

code. (1) A set of unambiguous rules specifying the manner in which data may be represented in a discrete form. Synonymous with coding scheme. (2) A set of items, such as abbreviations, representing the members of another set. (3) To represent data or a computer program in a symbolic form that can be accepted by a data processor. (4) Loosely, one or more computer programs, or part of a computer program.

coding scheme. Synonym for code.

collector. An element in a transistor toward which current flows.

column address strobe (CAS). A signal that latches the column addresses in a memory chip.

compile. (1) To translate a computer program expressed in a problem-oriented language into a computer-oriented language. (2) To prepare a machine-language program from a computer program written in another programming language by making use of the overall logic structure of the program, or generating more than one computer instruction for each symbolic statement, or both, as well as performing the function of an assembler.

complementary metal oxide semiconductor (CMOS). A logic circuit family that uses very little power. It works with a wide range of power supply voltages.

computer. A functional unit that can perform substantial computation, including numerous arithmetic operations or logic operations, without intervention by a human operator during a run.

computer instruction code. A code used to represent the instructions in an instruction set. Synonymous with machine code.

computer program. A sequence of instructions suitable for processing by a computer.

computer word. A word stored in one computer location and capable of being treated as a unit.

configuration. (1) The arrangement of a computer system or network as defined by the nature, number, and the chief characteristics of its functional units. More specifically, the term configuration may refer to a hardware configuration or a software configuration. (2) The devices and programs that make up a system, subsystem, or network.

conjunction. Synonym for AND operation.

contiguous. Touching or joining at the edge or boundary; adjacent.

control character. A character whose occurrence in a particular context initiates, modifies, or stops a control operation.

control operation. An action that affects the recording, processing, transmission, or interpretation of data; for example, starting or stopping a process, carriage return, font change, rewind, and end of transmission.

control storage. A portion of storage that contains microcode.

cps. Characters per second.

CPU. Central processing unit.

CRC. Cyclic redundancy check.

CRT. Cathode ray tube.

CRT display. Cathode ray tube display.

CTS. Clear to send. Associated with modem control.

cursor. (1) In computer graphics, a movable marker that is used to indicate a position on a display. (2) A displayed symbol that acts as a marker to help the user locate a point in text, in a system command, or in storage. (3) A movable spot of light on the screen of a display device, usually indicating where the next character is to be entered, replaced, or deleted.

cyclic redundancy check (CRC). (1) A redundancy check in which the check key is generated by a cyclic algorithm. (2) A system of error checking performed at both the sending and receiving station after a block-check character has been accumulated.

cylinder. (1) The set of all tracks with the same nominal distance from the axis about which the disk rotates. (2) The tracks of a disk storage device that can be accessed without repositioning the access mechanism.

daisy-chained cable. A type of cable that has two or more connectors attached in series.

data. (1) A representation of facts, concepts, or instructions in a formalized manner suitable for communication, interpretation, or processing by human or automatic means. (2) Any representations, such as characters or analog quantities, to which meaning is, or might be assigned.

data base. A collection of data that can be immediately accessed and operated upon by a data processing system for a specific purpose.

data processing system. A system that performs input, processing, storage, output, and control functions to accomplish a sequence of operations on data.

data transmission. Synonym for transmission.

dB. Decibel.

dBa. Adjusted decibels.

dc. Direct current.

debounce. An electronic means of overcoming the make/break bounce of switches to obtain one smooth change of signal level.

decibel. (1) A unit that expresses the ratio of two power levels on a logarithmic scale. (2) A unit for measuring relative power.

decoupling capacitor. A capacitor that provides a low impedance path to ground to prevent common coupling between circuits.

Deutsche Industrie Norm (DIN). (1) German Industrial Norm. (2) The committee that sets German dimension standards.

digit. (1) A graphic character that represents an integer; for example, one of the characters 0 to 9. (2) A symbol that

represents one of the non-negative integers smaller than the radix. For example, in decimal notation, a digit is one of the characters 0 to 9.

digital. (1) Pertaining to data in the form of digits. (2) Contrast with analog.

DIN. Deutsche Industrie Norm.

DIN connector. One of the connectors specified by the DIN committee.

DIP. Dual in-line package.

DIP switch. One of a set of small switches mounted in a dual in-line package.

direct current (dc). A current that always flows in one direction.

direct memory access (DMA). A method of transferring data between main storage and I/O devices that does not require processor intervention.

disable. To stop the operation of a circuit or device.

disabled. Pertaining to a state of a processing unit that prevents the occurrence of certain types of interruptions. Synonymous with masked.

disk. Loosely, a magnetic disk unit.

disk drive. A mechanism for moving a disk pack and controlling its movements.

disk pack. A removable assembly of magnetic disks.

diskette. A thin, flexible magnetic disk and a semirigid protective jacket, in which the disk is permanently enclosed. Synonymous with flexible disk.

diskette drive. A mechanism for moving a diskette and controlling its movements.

display. (1) A visual presentation of data. (2) A device for visual presentation of information on any temporary character imaging device. (3) To present data visually. (4) See cathode ray tube display.

display attribute. In computer graphics, a particular property that is assigned to all or part of a display; for example, low intensity, green color, blinking status.

DMA. Direct memory access.

dot matrix. (1) In computer graphics, a two-dimensional pattern of dots used for constructing a display image. This type of matrix can be used to represent characters by dots. (2) In word processing, a pattern of dots used to form characters. This term normally refers to a small section of a set of addressable points; for example, a representation of characters by dots.

dot printer. Synonym for matrix printer.

dot-matrix character generator. In computer graphics, a character generator that generates character images composed of dots.

DSR. Data set ready. Associated with modem control.

DTR. In the IBM Personal Computer, data terminal ready. Associated with modem control.

dual in-line package (DIP). A widely used container for an integrated circuit. DIPs have pins in two parallel rows. The pins are spaced 1/10 inch apart. See also DIP switch.

duplex. (1) In data communication, pertaining to a simultaneous two-way independent transmission in both directions. (2) Contrast with half-duplex.

duty cycle. In the operation of a device, the ratio of on time to idle time. Duty cycle is expressed as a decimal or percentage.

dynamic memory. RAM memory using transistors and capacitors as the memory elements. This memory requires a refresh (recharge) cycle every few milliseconds. Contrast with static memory.

EBCDIC. Extended binary-coded decimal interchange code.

ECC. Error checking and correction.

edge connector. A terminal block with a number of contacts attached to the edge of a printed-circuit board to facilitate plugging into a foundation circuit.

EIA. Electronic Industries Association.

electromagnet. Any device that exhibits magnetism only while an electric current flows through it.

enable. To initiate the operation of a circuit or device.

end of block (EOB). A code that marks the end of a block of data.

end of file (EOF). An internal label, immediately following the last record of a file, signaling the end of that file. It may include control totals for comparison with counts accumulated during processing.

end-of-text (ETX). A transmission control character used to terminate text.

end-of-transmission (EOT). A transmission control character used to indicate the conclusion of a transmission, which may have included one or more texts and any associated message headings.

end-of-transmission-block (ETB). A transmission control character used to indicate the end of a transmission block of data when data is divided into such blocks for transmission purposes.

EOB. End of block.

EOF. End of file.

EOT. End-of-transmission.

EPROM. Erasable programmable read-only memory.

erasable programmable read-only memory (EPROM). A PROM in which the user can erase old information and enter new information.

error checking and correction (ECC). The detection and correction of all single-bit errors, plus the detection of double-bit and some multiple-bit errors.

ESC. The escape character.

escape character (ESC). A code extension character used, in some cases, with one or more succeeding characters to indicate by some convention or agreement that the coded representations following the character or the group of characters are to be interpreted according to a different code or according to a different coded character set.

ETB. End-of-transmission-block.

ETX. End-of-text.

extended binary-coded decimal interchange code (EBCDIC). A set of 256 characters, each represented by eight bits.

F. Fahrenheit.

Fahrenheit (F). A temperature scale. Contrast with Celsius (C).

falling edge. Synonym for negative-going edge.

FCC. Federal Communications Commission.

fetch. To locate and load a quantity of data from storage.

FF. The form feed character.

field. (1) In a record, a specified area used for a particular category of data. (2) In a data base, the smallest unit of data that can be referred to.

fixed disk. In the IBM Personal Computer, synonym for disk drive.

flag. (1) Any of various types of indicators used for identification. (2) A character that signals the occurrence of some condition, such as the end of a word. (3) Deprecated term for mark.

flexible disk. Synonym for diskette.

flip-flop. A circuit or device containing active elements, capable of assuming either one of two stable states at a given time.

font. A family or assortment of characters of a given size and style; for example, 10 point Press Roman medium.

foreground. (1) In multiprogramming, the environment in which high-priority programs are executed. (2) On a color display screen, the characters as opposed to the background.

form feed. (1) Paper movement used to bring an assigned part of a form to the printing position. (2) In word processing, a function that advances the typing position to the same character position on a predetermined line of the next form or page.

form feed character. A control character that causes the print or display position to move to the next predetermined first line on the next form, the next page, or the equivalent.

format. The arrangement or layout of data on a data medium.

frame. (1) In SDLC, the vehicle for every command, every response, and all information that is transmitted using SDLC procedures. Each frame begins and ends with a flag. (2) In data transmission, the sequence of contiguous bits bracketed by and including beginning and ending flag sequences.

g. Gram.

G. (1) Prefix giga; 1 000 000 000. (2) When referring to computer storage capacity, 1 073 741 824. (1 073 741 824 = 2 to the 30th power.)

gate. (1) A combinational logic circuit having one output channel and one or more input channels, such that the output channel state is completely determined by the input channel states. (2) A signal that enables the passage of other signals through a circuit.

Gb.

1 073 741 824 bytes.

general-purpose register. A register, usually explicitly addressable within a set of registers, that can be used for different purposes; for example, as an accumulator, as an index register, or as a special handler of data.

giga (G). Prefix 1 000 000 000.

gram (g). A unit of weight (equivalent to 0.035 ounces).

graphic. A symbol produced by a process such as handwriting, drawing, or printing.

graphic character. A character, other than a control character, that is normally represented by a graphic.

half-duplex. (1) In data communication, pertaining to an alternate, one way at a time, independent transmission. (2) Contrast with duplex.

hardware. (1) Physical equipment used in data processing, as opposed to programs, procedures, rules, and associated documentation. (2) Contrast with software.

head. A device that reads, writes, or erases data on a storage medium; for example, a small electromagnet used to read, write, or erase data on a magnetic disk.

hertz (Hz). A unit of frequency equal to one cycle per second.

hex. Common abbreviation for hexadecimal.

hexadecimal. (1) Pertaining to a selection, choice, or condition that has 16 possible different values or states. These values or states are usually symbolized by the ten digits 0 through 9 and the six letters A through F. (2) Pertaining to a fixed radix numeration system having a radix of 16.

high impedance state. A state in which the output of a device is effectively isolated from the circuit.

highlighting. In computer graphics, emphasizing a given display group by changing its attributes relative to other display groups in the same display field.

high-order position. The leftmost position in a string of characters. See also most-significant digit.

housekeeping. Operations or routines that do not contribute directly to the solution of the problem but do contribute directly to the operation of the computer.

Hz. Hertz

image. A fully processed unit of operational data that is ready to be transmitted to a remote unit; when loaded into control storage in the remote unit, the image determines the operations of the unit.

immediate instruction. An instruction that contains within itself an operand for the operation specified, rather than an address of the operand.

index register. A register whose contents may be used to modify an operand address during the execution of computer instructions.

indicator. (1) A device that may be set into a prescribed state, usually according to the result of a previous process or on the occurrence of a specified condition in the equipment, and that usually gives a visual or other indication of the existence of the prescribed state, and that may in some cases be used to determine the selection among alternative processes; for example, an overflow indicator. (2) An item of data that may be interrogated to determine whether a particular condition has been satisfied in the execution of a computer program; for example, a switch indicator, an overflow indicator.

inhibited. (1) Pertaining to a state of a processing unit in which certain types of interruptions are not allowed to occur. (2) Pertaining to the state in which a transmission control unit or an audio response unit cannot accept incoming calls on a line.

initialize. To set counters, switches, addresses, or contents of storage to 0 or other starting values at the beginning of, or at prescribed points in, the operation of a computer routine.

input/output (I/O). (1) Pertaining to a device or to a channel that may be involved in an input process, and, at a different time, in an output process. In the English language, "input/output" may be

used in place of such terms "input/output data", "input/output signal", and "input/output terminals", when such usage is clear in a given context. (2) Pertaining to a device whose parts can be performing an input process and an output process at the same time. (3) Pertaining to either input or output, or both.

instruction. In a programming language, a meaningful expression that specifies one operation and identifies its operands, if any.

instruction set. The set of instructions of a computer, of a programming language, or of the programming languages in a programming system.

interface. A device that alters or converts actual electrical signals between distinct devices, programs, or systems.

interleave. To arrange parts of one sequence of things or events so that they alternate with parts of one or more other sequences of the same nature and so that each sequence retains its identity.

interrupt. (1) A suspension of a process, such as the execution of a computer program, caused by an event external to that process, and performed in such a way that the process can be resumed.

(2) In a data transmission, to take an action at a receiving station that causes the transmitting station to terminate a transmission.

(3) Synonymous with interruption.

I/O. Input/output.

I/O area. Synonym for buffer.

irrecoverable error. An error that makes recovery impossible without the use of recovery techniques external to the computer program or run.

joystick. In computer graphics, a lever that can pivot in all directions and that is used as a locator device.

k. Prefix kilo; 1000.

K. When referring to storage capacity, 1024. ($1024 = 2$ to the 10th power.)

Kb. 1024 bytes.

kg. Kilogram; 1000 grams.

kHz. Kilohertz; 1000 hertz.

kilo (k). Prefix 1000

kilogram (kg). 1000 grams.

kilohertz (kHz). 1000 hertz

latch. (1) A simple logic-circuit storage element. (2) A feedback loop in sequential digital circuits used to maintain a state.

least-significant digit. The rightmost digit. See also low-order position.

LED. Light-emitting diode.

light-emitting diode (LED). A semiconductor device that gives off visible or infrared light when activated.

load. In programming, to enter data into storage or working registers.

low power Schottky TTL. A version (LS series) of TTL giving a good compromise between low power and high speed. See also transistor-transistor logic and Schottky TTL.

low-order position. The rightmost position in a string of characters. See also least-significant digit.

m. (1) Prefix milli; 0.001. (2) Meter.

M. (1) Prefix mega; 1 000 000. (2) When referring to computer storage capacity, 1 048 576. (1 048 576 = 2 to the 20th power.)

mA. Milliampere; 0.001 ampere.

machine code. The machine language used for entering text and program instructions onto the recording medium or into storage and which is subsequently used for processing and printout.

machine language. (1) A language that is used directly by a machine. (2) Deprecated term for computer instruction code.

magnetic disk. (1) A flat circular plate with a magnetizable surface layer on which data can be stored by magnetic recording. (2) See also diskette.

main storage. (1) Program-addressable storage from which instructions and other data can be loaded directly into registers for subsequent execution or processing. (2) Contrast with auxiliary storage.

mark. A symbol or symbols that indicate the beginning or the end of a field, of a word, of an item of data, or of a set of data such as a file, a record, or a block.

mask. (1) A pattern of characters that is used to control the retention or elimination of portions of another pattern of characters. (2) To use a pattern of characters to control the retention or elimination of portions of another pattern of characters.

masked. Synonym for disabled.

matrix. (1) A rectangular array of elements, arranged in rows and columns, that may be manipulated according to the rules of matrix algebra. (2) In computers, a logic network in the form of an array of input leads and output leads with logic elements connected at some of their intersections.

matrix printer. A printer in which each character is represented by a pattern of dots; for example, a stylus printer, a wire printer. Synonymous with dot printer.

Mb. 1 048 576 bytes.

mega (M). Prefix 1 000 000.

megahertz (MHz). 1 000 000 hertz.

memory. Term for main storage.

meter (m). A unit of length (equivalent to 39.37 inches).

MFM. Modified frequency modulation.

MHz. Megahertz; 1 000 000 hertz.

micro (μ). Prefix 0.000 001.

microcode. (1) One or more microinstructions. (2) A code, representing the instructions of an instruction set, implemented in a part of storage that is not program-addressable.

microinstruction. (1) An instruction of microcode. (2) A basic or elementary machine instruction.

microprocessor. An integrated circuit that accepts coded instructions for execution; the instructions may be entered, integrated, or stored internally.

microsecond (μ s). 0.000 001 second.

milli (m). Prefix 0.001.

milliampere (mA). 0.001 ampere.

millisecond (ms). 0.001 second.

mnemonic. A symbol chosen to assist the human memory; for example, an abbreviation such as "mpy" for "multiply".

mode. (1) A method of operation; for example, the binary mode, the interpretive mode, the alphanumeric mode. (2) The most frequent value in the statistical sense.

modem (modulator-demodulator). A device that converts serial (bit by bit) digital signals from a business machine (or data communication equipment) to analog signals that are suitable for transmission in a telephone network. The inverse function is also performed by the modem on reception of analog signals.

modified frequency modulation (MFM). The process of varying the amplitude and frequency of the 'write' signal. MFM pertains to the number of bytes of storage that can be stored on the recording media. The number of bytes is twice the number contained in the same unit area of recording media at single density.

modulation. The process by which some characteristic of one wave (usually high frequency) is varied in accordance with another wave or signal (usually low frequency). This technique is used in modems to make business-machine signals compatible with communication facilities.

modulation rate. The reciprocal of the measure of the shortest nominal time interval between successive significant instants of the modulated signal. If this measure is expressed in seconds, the modulation rate is expressed in baud.

module. (1) A program unit that is discrete and identifiable with respect to compiling, combining with other units, and loading. (2) A packaged functional hardware unit designed for use with other components.

modulo check. A calculation performed on values entered into a system. This calculation is designed to detect errors.

monitor. (1) A device that observes and verifies the operation of a data processing system and indicates any significant departure from the norm. (2) Software or hardware that observes, supervises, controls, or verifies the operations of a system.

most-significant digit. The leftmost (non-zero) digit. See also high-order position.

ms. Millisecond; 0.001 second.

multiplexer. A device capable of interleaving the events of two or more activities, or capable of distributing the events of an interleaved sequence to the respective activities.

multiprogramming. (1) Pertaining to the concurrent execution of two or more computer programs by a computer. (2) A mode of operation that provides for the interleaved execution of two or more computer programs by a single processor.

n. Prefix nano; 0.000 000 001.

NAND. A logic operator having the property that if P is a statement, Q is a statement, R is a statement,..., then the NAND of P, Q ,R,... is true if at least one statement is false, false if all statements are true.

NAND gate. A gate in which the output is 0 only if all inputs are 1.

nano (n). Prefix 0.000 000 001.

nanosecond (ns). 0.000 000 001 second.

negative true. Synonym for active low.

negative-going edge. The edge of a pulse or signal changing in a negative direction. Synonymous with falling edge.

non-return-to-zero change-on-ones recording (NRZI). A transmission encoding method in which the data terminal equipment changes the signal to the opposite state to send a binary 1 and leaves it in the same state to send a binary 0.

non-return-to-zero (inverted) recording (NRZI). Deprecated term for non-return-to-zero change-on-ones recording.

NOR. A logic operator having the property that if P is a statement, Q is a statement, R is a statement,..., then the NOR of P, Q, R,... is true if all statements are false, false if at least one statement is true.

NOR gate. A gate in which the output is 0 only if at least one input is 1.

NOT. A logical operator having the property that if P is a statement, then the NOT of P is true if P is false, false if P is true.

NRZI. Non-return-to-zero change-on-ones recording.

ns. Nanosecond; 0.000 000 001 second.

NUL. The null character.

null character (NUL). A control character that is used to accomplish media-fill or time-fill, and that may be inserted into or removed from, a sequence of characters without affecting the meaning of the sequence; however, the control of the equipment or the format may be affected by this character.

odd-even check. Synonym for parity check.

offline. Pertaining to the operation of a functional unit without the continual control of a computer.

one-shot. A circuit that delivers one output pulse of desired duration for each input (trigger) pulse.

open circuit. (1) A discontinuous circuit; that is, one that is broken at one or more points and, consequently, cannot conduct current. Contrast with closed circuit. (2) Pertaining to a no-load condition; for example, the open-circuit voltage of a power supply.

open collector. A switching transistor without an internal connection between its collector and the voltage supply. A connection from the collector to the voltage supply is made through an external (pull-up) resistor.

operand. (1) An entity to which an operation is applied. (2) That which is operated upon. An operand is usually identified by an address part of an instruction.

operating system. Software that controls the execution of programs; an operating system may provide services such as resource allocation, scheduling, input/output control, and data management.

OR. A logic operator having the property that if P is a statement, Q is a statement, R is a statement,..., then the OR of P, Q, R,... is true if at least one statement is true, false if all statements are false.

OR gate. A gate in which the output is 1 only if at least one input is 1.

output. Pertaining to a device, process, or channel involved in an output process, or to the data or states involved in an output process.

output process. (1) The process that consists of the delivery of data from a data processing system, or from any part of it. (2) The return of information from a data processing system to an end user, including the translation of data from a machine language to a language that the end user can understand.

overcurrent. A current of higher than specified strength.

overflow indicator. (1) An indicator that signifies when the last line on a page has been printed or passed. (2) An indicator that is set on if the result of an arithmetic operation exceeds the capacity of the accumulator.

overrun. Loss of data because a receiving device is unable to accept data at the rate it is transmitted.

overvoltage. A voltage of higher than specified value.

parallel. (1) Pertaining to the concurrent or simultaneous operation of two or more devices, or to the concurrent performance of two or more activities. (2) Pertaining to the concurrent or simultaneous occurrence of two or more related activities in multiple devices or channels. (3) Pertaining to the simultaneity of two or more processes. (4) Pertaining to the simultaneous processing of the individual parts of a whole, such as the bits of a character and the characters of a word, using separate facilities for the various parts. (5) Contrast with serial.

parameter. (1) A variable that is given a constant value for a specified application and that may denote the application. (2) A name in a procedure that is used to refer to an argument passed to that procedure.

parity bit. A binary digit appended to a group of binary digits to make the sum of all the digits either always odd (odd parity) or always even (even parity).

parity check. (1) A redundancy check that uses a parity bit. (2) Synonymous with odd-even check.

PEL. Picture element.

personal computer. A small home or business computer that has a processor and keyboard and that can be connected to a television or some other monitor. An optional printer is usually available.

phototransistor. A transistor whose switching action is controlled by light shining on it.

picture element (PEL). The smallest displayable unit on a display.

polling. (1) Interrogation of devices for purposes such as to avoid contention, to determine operational status, or to determine readiness to send or receive data. (2) The process whereby stations are invited, one at a time, to transmit.

port. An access point for data entry or exit.

positive true. Synonym for active high.

positive-going edge. The edge of a pulse or signal changing in a positive direction. Synonymous with rising edge.

potentiometer. A variable resistor with three terminals, one at each end and one on a slider (wiper).

power supply. A device that produces the power needed to operate electronic equipment.

printed circuit. A pattern of conductors (corresponding to the wiring of an electronic circuit) formed on a board of insulating material.

printed-circuit board. A usually copper-clad plastic board used to make a printed circuit.

priority. A rank assigned to a task that determines its precedence in receiving system resources.

processing program. A program that performs such functions as compiling, assembling, or translating for a particular programming language.

processing unit. A functional unit that consists of one or more processors and all or part of internal storage.

processor. (1) In a computer, a functional unit that interprets and executes instructions. (2) A functional unit, a part of another unit such as a terminal or a processing unit, that interprets and executes instructions. (3) Deprecated term for processing program. (4) See microprocessor.

program. (1) A series of actions designed to achieve a certain result. (2) A series of instructions telling the computer how to handle a problem or task. (3) To design, write, and test computer programs.

programmable read-only memory (PROM). A read-only memory that can be programmed by the user.

programming language. (1) An artificial language established for expressing computer programs. (2) A set of characters and rules with meanings assigned prior to their use, for writing computer programs.

programming system. One or more programming languages and the necessary software for using these languages with particular automatic data-processing equipment.

PROM. Programmable read-only memory.

propagation delay. (1) The time necessary for a signal to travel from one point on a circuit to another. (2) The time delay between a signal change at an input and the corresponding change at an output.

protocol. (1) A specification for the format and relative timing of information exchanged between communicating parties. (2) The set of rules governing the operation of functional units of a communication system that must be followed if communication is to be achieved.

pulse. A variation in the value of a quantity, short in relation to the time schedule of interest, the final value being the same as the initial value.

radio frequency (RF). An ac frequency that is higher than the highest audio frequency. So called because of the application to radio communication.

radix. (1) In a radix numeration system, the positive integer by which the weight of the digit place is multiplied to obtain the weight of the digit place with the next higher weight; for example, in the decimal numeration system the radix of each digit place is 10. (2) Another term for base.

radix numeration system. A positional representation system in which the ratio of the weight of any one digit place to the weight

of the digit place with the next lower weight is a positive integer (the radix). The permissible values of the character in any digit place range from 0 to one less than the radix.

RAM. Random access memory. Read/write memory.

random access memory (RAM). Read/write memory.

RAS. In the IBM Personal Computer, row address strobe.

raster. In computer graphics, a predetermined pattern of lines that provides uniform coverage of a display space.

read. To acquire or interpret data from a storage device, from a data medium, or from another source.

read-only memory (ROM). A storage device whose contents cannot be modified. The memory is retained when power is removed.

read/write memory. A storage device whose contents can be modified. Also called RAM.

recoverable error. An error condition that allows continued execution of a program.

red-green-blue-intensity (RGBI). The description of a direct-drive color monitor that accepts input signals of red, green, blue, and intensity.

redundancy check. A check that depends on extra characters attached to data for the detection of errors. See cyclic redundancy check.

register. (1) A storage device, having a specified storage capacity such as a bit, a byte, or a computer word, and usually intended for a special purpose. (2) A storage device in which specific data is stored.

retry. To resend the current block of data (from the last EOB or ETB) a prescribed number of times, or until it is entered correctly or accepted.

reverse video. A form of highlighting a character, field, or cursor by reversing the color of the character, field, or cursor with its background; for example, changing a red character on a black background to a black character on a red background.

RF. Radio frequency.

RF modulator. The device used to convert the composite video signal to the antenna level input of a home TV.

RGBI. Red-green-blue-intensity.

rising edge. Synonym for positive-going edge.

ROM. Read-only memory.

ROM/BIOS. The ROM resident basic input/output system, which provides the level control of the major I/O devices in the computer system.

row address strobe (RAS). A signal that latches the row address in a memory chip.

RS-232C. A standard by the EIA for communication between computers and external equipment.

RTS. Request to send. Associated with modem control.

run. A single continuous performance of a computer program or routine.

schematic. The representation, usually in a drawing or diagram form, of a logical or physical structure.

Schottky TTL. A version (S series) of TTL with faster switching speed, but requiring more power. See also transistor-transistor logic and low power Schottky TTL.

SDLC. Synchronous Data Link Control

sector. That part of a track or band on a magnetic drum, a magnetic disk, or a disk pack that can be accessed by the magnetic heads in the course of a predetermined rotational displacement of the particular device.

SERDES. Serializer/deserializer.

serial. (1) Pertaining to the sequential performance of two or more activities in a single device. In English, the modifiers serial and parallel usually refer to devices, as opposed to sequential and consecutive, which refer to processes. (2) Pertaining to the sequential or consecutive occurrence of two or more related activities in a single device or channel. (3) Pertaining to the sequential processing of the individual parts of a whole, such as the bits of a character or the characters of a word, using the same facilities for successive parts. (4) Contrast with parallel.

serializer/deserializer (SERDES). A device that serializes output from, and deserializes input to, a business machine.

setup. (1) In a computer that consists of an assembly of individual computing units, the arrangement of interconnections between the units, and the adjustments needed for the computer to operate. (2) The preparation of a computing system to perform a job or job step. Setup is usually performed by an operator and often involves performing routine functions, such as mounting tape reels. (3) The preparation of the system for normal operation.

short circuit. A low-resistance path through which current flows, rather than through a component or circuit.

signal. A variation of a physical quantity, used to convey data.

sink. A device or circuit into which current drains.

software. (1) Computer programs, procedures, and rules concerned with the operation of a data processing system. (2) Contrast with hardware.

source. The origin of a signal or electrical energy.

square wave. An alternating or pulsating current or voltage whose waveshape is square.

square wave generator. A signal generator delivering an output signal having a square waveform.

SS. Start-stop.

start bit. (1) A signal to a receiving mechanism to get ready to receive data or perform a function. (2) In a start-stop system, a signal preceding a character or block that prepares the receiving device for the reception of the code elements.

start-of-text (STX). A transmission control character that precedes a text and may be used to terminate the message heading.

start-stop system. A data transmission system in which each character is preceded by a start bit and is followed by a stop bit.

start-stop (SS) transmission. (1) Asynchronous transmission such that a group of signals representing a character is preceded by a start bit and followed by a stop bit. (2) Asynchronous transmission in which a group of bits is preceded by a start bit that prepares the receiving mechanism for the reception and registration of a character and is followed by at least one stop bit that enables the receiving mechanism to come to an idle condition pending the reception of the next character.

static memory. RAM memory using flip-flops as the memory elements. Data is retained as long as power is applied to the flip-flops. Contrast with dynamic memory.

stop bit. (1) A signal to a receiving mechanism to wait for the next signal. (2) In a start-stop system, a signal following a character or block that prepares the receiving device for the reception of a subsequent character or block.

storage. (1) A storage device. (2) A device, or part of a device, that can retain data. (3) The retention of data in a storage device. (4) The placement of data into a storage device.

strobe. An instrument that emits adjustable-rate flashes of light. Used to measure the speed of rotating or vibrating objects.

STX. Start-of-text.

symbol. (1) A conventional representation of a concept or a representation of something by reason of relationship, association, or convention. (2) A representation of something by reason of relationship, association, or convention.

synchronization. The process of adjusting the corresponding significant instants of two signals to obtain the desired phase relationship between these instants.

Synchronous Data Link Control (SDLC). A protocol for management of data transfer over a data link.

synchronous transmission. (1) Data transmission in which the time of occurrence of each signal representing a bit is related to a fixed time frame. (2) Data transmission in which the sending and receiving devices are operating continuously at substantially the same frequency and are maintained, by means of correction, in a desired phase relationship.

syntax. (1) The relationship among characters or groups of characters, independent of their meanings or the manner of their

interpretation and use. (2) The structure of expressions in a language. (3) The rules governing the structure of a language. (4) The relationships among symbols.

text. In ASCII and data communication, a sequence of characters treated as an entity if preceded and terminated by one STX and one ETX transmission control character, respectively.

time-out. (1) A parameter related to an enforced event designed to occur at the conclusion of a predetermined elapsed time. A time-out condition can be cancelled by the receipt of an appropriate time-out cancellation signal. (2) A time interval allotted for certain operations to occur; for example, response to polling or addressing before system operation is interrupted and must be restarted.

track. (1) The path or one of the set of paths, parallel to the reference edge on a data medium, associated with a single reading or writing component as the data medium moves past the component. (2) The portion of a moving data medium such as a drum, or disk, that is accessible to a given reading head position.

transistor-transistor logic (TTL). A popular logic circuit family that uses multiple-emitter transistors.

translate. To transform data from one language to another.

transmission. (1) The sending of data from one place for reception elsewhere. (2) In ASCII and data communication, a series of characters including headings and text. (3) The dispatching of a signal, message, or other form of intelligence by wire, radio, telephone, or other means. (4) One or more blocks or messages. For BSC and start-stop devices, a transmission is terminated by an EOT character. (5) Synonymous with data transmission.

TTL. Transistor-transistor logic.

V. Volt.

video. Computer data or graphics displayed on a cathode ray tube, monitor, or display.

volt. The basic practical unit of electric pressure. The potential that causes electrons to flow through a circuit.

W. Watt.

watt. The practical unit of electric power.

word. (1) A character string or a bit string considered as an entity. (2) See computer word.

write. To make a permanent or transient recording of data in a storage device or on a data medium.

write precompensation. The varying of the timing of the head current from the outer tracks to the inner tracks of the diskette to keep a constant 'write' signal.

Notes:



Bibliography

- Microprocessor and Peripheral Handbook
 - INTEL Corporation. *210844.001*
- Introduction to the iAPX 286
 - INTEL Corporation. *210308.001*
- iAPX 286 Operating Systems Writer's Guide
 - INTEL Corporation. *121960.001*
- iAPX 286 Programmer's Reference Manual
 - INTEL Corporation. *210498.001*
- iAPX 286 Hardware Reference Manual
 - INTEL Corporation. *210760.001*
- Numeric Processor Extension Data Sheet
 - INTEL Corporation. *210920*
- 80287 Support Library Reference Manual
 - INTEL Corporation. *122129*
- National Semiconductor Corporation. *NS16450*
- Motorola Microprocessor's Data Manual
 - Motorola Inc. *Series B*

Notes:



Index

A

AAA 6-8
AAD 6-9
AAM 6-9
AAS 6-9
access time, track-to-track 9-22
ADC 6-6
ADD 6-6
additional ROM modules 5-12
address generation, DMA 1-13
address latch enable 1-26
address latch enable, buffered 1-23
address mode
 real 1-4
address space, I/O 1-15
address, segment 1-4
addresses, CMOS RAM 1-45
addresses, page register 1-13
AEN 1-23, 1-26
ALE 9-3
alternate key 5-19
AND 6-10
APL 9-5
application guidelines 9-5
arithmetic instructions 6-6, 6-27
ARPL 6-22
ASCII, extended 5-12

B

- BALE 1-22, 1-23
- bandwidth 1-7
- BASIC 9-5
- basic assurance test 4-4
- BASIC interrupts 5-6
- BAT 4-4
- battery connector 1-58
- BHE 1-13
- BIOS fixed disk parameters 1-51
- BIOS memory map 5-10
- BIOS programming hints 5-10
- block diagram
 - keyboard interface 1-38
 - system xv
 - system board 1-6
 - system timer 1-9
- board, system 1-3
- BOUND 6-19
- break code 4-4, 4-10
- break key 5-19
- buffer, keyboard 4-3
- buffered address latch enable 1-23
- buffers, video display 9-10
- bus controller 1-23
- bus cycle 1-7
- busy loop 9-11
- bypassing BIOS 9-22
- byte high enable 1-13

C

- CALL 6-14
- cancellation, multi-tasking 9-21
- capacitor, variable 1-31
- caps lock key 5-19
- CBW 6-10

- channel, I/O 1-15
- channels, DMA 1-7, 1-12, 1-15
- character codes 5-13
- classes, wait loop 9-13
- CLC 6-19
- CLD 6-20
- CLI 6-20
- CLK 1-22
- clock
 - real-time 1-45
- clock cycle 1-7
- clock line, keyboard 1-43, 4-5, 4-14, 4-15
- clock, system 1-22
- CMC 6-19
- CMOS RAM 1-45
- CMOS RAM addresses 1-45
- CMOS RAM configuration 1-48
- CMOS RAM I/O operations 1-54
- CMP 6-8
- CMPS 6-12, 6-13
- COBAL 9-5
- code
 - device driver 9-11
 - machine identification 9-23
 - machine-sensitive 9-23
- codes
 - character 5-13
 - extended 5-17
 - multi-tasking function 9-11
- color burst signal 1-31
- command codes, DMA controller 1-14
- commands
 - I/O 9-8
 - keyboard 4-12
 - keyboard controller 1-40
 - keyboard system 4-5
- comparison instructions 6-25
- compatibility, hardware 9-3
- completion, multi-tasking 9-21
- condition, wait 9-12
- configuration record 1-45
- configuration, CMOS RAM 1-48

- connectors
 - battery 1-58
 - I/O channel 1-15, 1-17, 1-18, 1-19
 - keyboard 1-58, 4-23
 - power LED and keylock 1-58
 - power supply 1-57
 - power supply output 3-6
 - speaker 1-57
 - system board 1-57
- constants instructions 6-26
- control
 - game 9-10
 - sound 9-10
- control key 5-19
- control transfer instructions 6-13
- controller, keyboard 1-31
- controllers
 - bus 1-23
 - DMA 1-7, 1-12, 1-13, 1-22
 - interrupt 1-10
 - refresh 1-7
- controls, math coprocessor 1-29
- coprocessor programming 2-3
- coprocessor, math 2-3
- copy protection 9-11, 9-22
- Ctrl state 5-17
- CTS 6-20
- CWD 6-10
- cycle
 - bus 1-7
 - clock 1-7
 - microprocessor 1-7

D

- DACK0-DACK3 1-26
- DACK5-DACK7 1-26
- DAS 6-9
- data area, ROM BIOS 9-10
- data communication equipment 8-3
- data input, keyboard 4-15

data line, keyboard 1-43, 4-5, 4-14, 4-15
data output, keyboard 4-15
data stream 4-14
data terminal equipment 8-3
data transfer instructions 6-3, 6-24
data transfer rate, diskette 9-22
DEC 6-8
decodes, memory 1-22, 1-23
default segment workspace 5-9
descriptors 1-5
device driver code 9-11
diagnostic checkpoint port 1-29
direct memory access 1-12
disk pointer 9-8
disk_base 9-8, 9-22
diskette change signal 9-23
diskette data transfer rate 9-22
diskette rotational speed 9-22
diskette track density 9-22
diskette write current 9-23
DIV 6-9
divide error exception 9-7
DMA 1-12
DMA address generation 1-13
DMA channels 1-7, 1-12, 1-15
DMA controller 1-7, 1-22
DMA controller command codes 1-14
DMA controller 1 1-12
DMA controller 2 1-13
DMA controllers 1-12
DOS 9-6
DOS function calls 9-7
DOS interrupts 5-6
DRQ0-DRQ3 1-25
DRQ5-DRQ7 1-25
dummy load 3-4

E

EIA/CCITT 8-3
encoding, keyboard 5-12
ENTER 6-18
ESC 6-20
exception, divide error 9-7
extended ASCII 5-12
extended codes 5-17

F

FABS 6-28
FADD 6-27
fan out 3-6
FCHS 6-28
FCLEX 6-30
FCOM 6-25
FCOMP 6-25
FCOMPP 6-26
FDECSTP 6-31
FDIV 6-27
FFREE 6-31
FIFO 4-3
FINCSTP 6-31
FINT 6-29
FLD 6-24
FLDCW 6-30
FLDENV 6-30
FLDLG2 6-27
FLDLN2 6-27
FLDL2T 6-26
FLDP1 6-26
FLDZ 6-26
FLD1 6-26
FMUL 6-27
FNOP 6-31
FORTRAN 9-5

FPATAN 6-29
FPREM 6-28
FPTAN 6-29
French keyboard 4-19
FRNDINT 6-28
FRSTOR 6-30
FSAVE 6-30
FSCALE 6-28
FSETPM 6-29
FSQRT 6-28
FST 6-24
FSTCW 6-30
FSTENV 6-30
FSTP 6-25
FSTSW 6-30
FSTSWAX 6-30
FSUB 6-27
FTST 6-26
function calls, DOS 9-7
function codes, multi-tasking 9-14
FXAM 6-26
FXCH 6-25
FXTRACT 6-28
FYL2X 6-29
FYL2XP1 6-29
F2XM1 6-29

G

game control 9-10
gap length parameter 9-9
generator, refresh request 1-8
German keyboard 4-20
graphics modes 5-8
guidelines, application 9-5

H

hard code 5-10
hardware compatibility 9-3
hardware interrupts 5-6
HLT 6-20
hooks 9-11

I

I/O address map 1-28
I/O address space 1-15
I/O CH CK 1-23, 1-30
I/O CH RDY 1-24
I/O channel 1-15
I/O channel check 1-23
I/O channel connectors 1-15, 1-17, 1-18, 1-19
I/O channel ready 1-24
I/O channel signals 1-22
I/O chip select 1-27
I/O commands 9-7
I/O CS16 1-27
I/O ports, keyboard controller 1-43
I/O read 1-24
I/O write 1-24
IDIV 6-9
IIMUL 6-9
IMR 9-10
IMUL 6-9
IN 6-5
INC 6-7
inhibit keyboard 1-37
input buffer, keyboard controller 1-40
input port, keyboard controller 1-44
input requirements 3-3
inputs, power supply 3-3
INS 6-12, 6-13

instructions

- arithmetic 6-6, 6-27
- comparison 6-25
- constants 6-26
- control transfer 6-13
- data transfer 6-3, 6-24
- logic 6-10
- processor control 6-19
- protection control 6-21
- shift rotate 6-10
- string manipulation 6-12

INT 6-18

- interface, keyboard 4-3
- interfaces, multi-tasking 9-12
- interfaces, SYS code 9-18
- interrupt controller 1-10
- interrupt mask register 9-10
- interrupt service routine 1-24
- interrupt vectors 9-10
- interrupt, single step 9-7
- interrupts 1-15, 5-5
 - BASIC 5-6
 - DOS 5-6
 - hardware 5-6
 - program 5-3
 - system 1-10

INTO 6-19

IOR 1-24

IOW 1-24

IRET 6-19

IRQ 2 9-8

IRQ 9 9-4, 9-8

IRQ14-IRQ15 1-24

IRQ3-IRQ7 1-24

IRQ9 1-24

Italian keyboard 4-21

J

JB/JNAE 6-16

JBE/JNA 6-16

JCXZ 6-18
JE/JZ 6-16
JL/JNGE 6-16
JLE/JNG 6-16
JMP 6-14
JNB/JAE 6-17
JNBE/JA 6-17
JNE/JNZ 6-16
JNL/JGE 6-17
JNLE/JG 6-17
JNO 6-17
JNP/JPO 6-17
JNS 6-17
JO 6-16
joystick support 5-6
JP/JPE 6-16
JS 6-16
jumper, RAM 1-30

K

key scan codes 4-10
keyboard
 buffer 4-3
 clock line 1-43, 4-5, 4-14, 4-15
 commands 4-12
 connector 1-58, 4-23
 controller 1-31
 controller commands 1-40
 controller I/O ports 1-43
 controller input buffer 1-40
 controller input port 1-44
 controller output buffer 1-40
 controller output port 1-44
 controller status register 1-38
 controller test input port 1-44
 data input 4-15
 data line 1-43, 4-5, 4-14, 4-15
 data output 4-15
 encoding 5-12

- inhibit switch 1-37
- interface 4-3
- interface block diagram 1-38
- layout 1-33, 4-10, 5-14
- outputs 4-10
- routine 5-21
- specifications 4-23
- system commands 4-5
- keyboard, French 4-19
- keyboard, German 4-20
- keyboard, Italian 4-21
- keyboard, Spanish 4-22
- keyboard, U.K. English 4-18
- keyboard, U.S. English 4-17
- keylock 4-3
- keys 4-3
 - alternate 5-19
 - break 5-19
 - caps lock 5-19
 - combinations 5-20
 - control 5-19
 - number lock 5-20
 - pause 5-19
 - print screen 5-19
 - scroll lock 5-20
 - shift 5-18
 - SYS REQ 9-15
 - system request 5-6, 5-20
- keys, typematic 4-4

L

- LAHF 6-6
- LAR 6-22
- layout system board 1-60
- layout, keyboard 1-33, 4-10, 5-14
- LA17-LA23 1-22
- LDS 6-5
- LEA 6-5
- LEAVE 6-18

LED 4-4
LES 6-6
LGDT 6-21
LIDT 6-21
light emitting diodes 4-4
line contention 4-15
line, multipoint 8-5
line, point-to-point 8-5
LLDT 6-21
LMSW 6-22
load current 3-3
LOCK 6-20
LODS 6-12, 6-13
logic instructions 6-10
LOOP 6-17
loop, busy 9-12
LOOPNZ/LOOPNE 6-18
loops, program 9-10
LOOPZ/LOOPE 6-18
LSL 6-22
LTR 6-21

M

machine identification code 9-23
machine-sensitive code 9-23
make code 4-3, 4-10
mask off 1-29
mask on 1-29
master 1-26
math coprocessor 2-3, 9-6
math coprocessor controls 1-29
MEM chip select 1-27
MEM CS16 1-27
memory 1-4
memory decodes 1-22, 1-23
memory locations, reserved 5-9
memory map, BIOS 5-10
MEMR 1-25
MEMW 1-25

microprocessor 1-3, 1-4, 1-7
microprocessor cycle 1-7
modes, graphic 5-8
modules, RAM 1-12
modules, ROM/EPROM 1-11
MOV 6-3
MOVS 6-12, 6-13
MUL 6-9
multi-tasking
 cancellation 9-21
 completion 9-21
 function codes 9-14
 interfaces 9-12
 provisions 9-11
 serialization 9-12
 startup 9-12, 9-20
 subsystems 9-16
multipoint line 8-5

N

NEG 6-8
network, nonswitched 8-5
network, switched 8-5
NMI 1-10, 1-29
no load protection 3-5
non-maskable interrupt 1-29
nonswitched network 8-5
NOT 6-12
Num Lock state 5-17
number lock key 5-20

O

operations, CMOS RAM I/O 1-54
OR 6-11

- OSC 1-27, 1-31
- oscillator 1-27
- OUT 6-5
- output buffer, keyboard controller 1-40
- output port, keyboard controller 1-44
- output protection 3-4
- output voltage sense levels 3-6
- output voltage sequencing 3-4
- outputs, keyboard 4-10
- outputs, power supply 3-3
- OUTS 6-13

P

- page register addresses 1-13
- parameter
 - gap length 9-9
 - passing 5-4
 - tables 9-8
- parameters, BIOS fixed disk 1-51
- PASCAL 9-5
- pause key 5-19
- performance, system 1-7
- point-to-point line 8-5
- POP 6-4
- POPA 6-4
- POPF 6-6. 9-6
- POR 4-4
- port, diagnostic checkpoint 1-29
- POST 9-12
- power good signal 3-5, 3-6
- power LED and keylock connector 1-58
- power on reset 4-4
- power supply
 - connectors 1-57
 - inputs 3-3
 - output connectors 3-6
 - outputs 3-3
- print screen key 5-19
- priorities, shift key 5-20

- processor control instructions 6-19
- program interrupts 5-3
- program loops 9-11
- programming hints, BIOS 5-10
- programming, coprocessor 2-3
- protected mode 1-5, 5-6
- protection control instructions 6-21
- protection, no load 3-5
- provisions, multitasking 9-11
- PUSH 6-4
- PUSH SP 9-7
- PUSHA 6-4
- PUSHF 6-6

R

- RAM jumper 1-30
- RAM modules 1-12
- RAM subsystem 1-12
- RAM, CMOS 1-45
- rate, typematic 4-4, 4-7
- real address mode 1-4, 2-5
- real mode 5-3
- real-time clock 1-45
- record, configuration 1-45
- refid=admod.virtual 1-4
- REFRESH 1-26
- refresh controller 1-7
- refresh request generator 1-8
- regulation tolerance 3-3
- requirements, input 3-3
- reserved memory locations 5-9
- reserved scan codes 1-36
- RESET DRV 1-23
- reset, system 5-21
- RET 6-15
- ROM BIOS 9-7
- ROM BIOS data area 9-10
- ROM modules, additional 5-12
- ROM scan codes 5-12

ROM subsystem 1-11
ROM/EPROM modules 1-11
rotational, speed 9-22
routine, interrupt service 1-24
routine, keyboard 5-21
RS-232 8-3

S

SAHF 6-6
SA0-SA19 1-22
SBB 6-7
SBHE 1-26
scan code translation 1-32
scan codes 4-12
scan codes, key 4-10
scan codes, ROM 5-12
SCAS 6-12, 6-13
scroll lock key 5-20
SD)-SD15 1-23
segment address 1-4
segments 1-4
sense levels, output voltage 3-6
sequencing, output voltage 3-4
serialization, multi-tasking 9-12
SGDT 6-21
shift counts 9-7
shift key 5-18
shift key priorities 5-20
shift rotate instructions 6-10
Shift state 5-17
shift states 5-18
SIDT 6-21
signals
 diskette change 9-23
 power good 3-5, 3-6
 system clock 9-3
signals, I/O channels 1-22
single step interrupt 9-7
SLDT 6-21

- SMEMR 1-25
- SMEMW 1-25
- SMSW 6-22
- sound control 9-10
- Spanish keyboard 4-22
- speaker 1-30
- speaker connector 1-57
- speaker tone generation 1-9
- special vectors 5-6
- specifications, keyboard 4-23
- startup, multi-tasking 9-12, 9-18
- states
 - Ctrl 5-17
 - Num Lock 5-17
 - Shift 5-17
- status register, keyboard controller 1-38
- STC 6-19
- STD 6-20
- STI 6-20
- STOS 6-12, 6-13
- STR 6-22
- string manipulation instructions 6-12
- SUB 6-7
- subsystem, RAM 1-12
- subsystem, ROM 1-11
- subsystems, multi-tasking 9-16
- support joystick 5-6
- switched network 8-5
- switches
 - keyboard inhibit 1-37
 - type of display 1-31
- SYS code interfaces 9-18
- SYS REQ key 9-15
- system BIOS usage 5-3
- system block diagram xv
- system board 1-3
- system board block diagram 1-6
- system board connectors 1-57
- system board layout 1-60
- system bus high enable 1-26
- system clock 1-22
- system clock signal 9-3
- system interrupts 1-10

system performance 1-7
system request key 5-6, 5-20
system reset 5-21
system timer block diagram 1-9
system timers 1-8

T

T/C 1-26
table, translation 1-34
tables, parameter 9-8
terminal count 1-26
TEST 6-11
test input port, keyboard controller 1-44
timeouts 9-15
timer/counter 1-9
timer/counters 1-8
timers, system 1-8
tone generation, speaker 1-9
track density, diskette 9-22
track-to-track access time 9-22
translation table 1-34
translation, scan code 1-32
tri-state 1-26
type of display adapter switch 1-31
typematic keys 4-4
typematic rate 4-4, 4-7

U

U.K. English keyboard 4-18
U.S. English keyboard 4-17

V

variable capacitor 1-31
vectors, special 5-6
VERR 6-22
video display buffers 9-10
virtual address mode 1-4, 2-5

W

WAIT 6-20
wait condition 9-12
wait loop classes 9-13
workspace, default segment 5-9
write current, diskette 9-23

X

XCHG 6-5
XLAT 6-5
XOR 6-11

Z

zero wait state 1-27

Numerals

OWS 1-27
80286 1-3, 1-4, 1-7
8042 1-31
82288 1-23
8237A-5 1-12
8254-2 1-8
8259A 1-10



Reader's Comment Form

Technical Reference

1502494

Your comments assist us in improving the usefulness of our publication; they are an important part of the input used for revisions.

IBM may use and distribute any of the information you supply in any way it believes appropriate without incurring any obligation whatever. You may, of course, continue to use the information you supply.

Please do not use this form for technical questions regarding the IBM Personal Computer or programs for the IBM Personal Computer, or for requests for additional publications; this only delays the response. Instead, direct your inquiries or request to your authorized IBM Personal Computer dealer.

Comments:

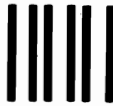

**NO POSTAGE
NECESSARY
IF MAILED
IN THE
UNITED STATES**

BUSINESS REPLY MAIL

FIRST CLASS PERMIT NO. 321 BOCA RATON, FLORIDA 33432

POSTAGE WILL BE PAID BY ADDRESSEE

IBM PERSONAL COMPUTER
SALES & SERVICE
P.O. BOX 1328-C
BOCA RATON, FLORIDA 33432



Fold here