

GX33-1508-3

4245 Printer  
Models 12 and 20  
Reference Summary  
for Operators

## Contents

Unit Emergency Switch .....	1
Front Operator Panel .....	1
Rear Operator Panel .....	3
Auxiliary Operator Panel .....	3
Adjustment Knobs .....	4
Initial Forms Loading .....	5
Starting First Job .....	6
Removing Forms at End of Job .....	7
Reloading Forms of Same Type .....	7
Adjustable Stacker .....	8
Stacker Adjustment .....	8
Machines with fixed or moveable Photocell .....	8
Forms up to 356 mm (14 in.) long ....	8
Forms longer than 356 mm (14 in.) ...	9
Lever/Indicator Photocell (only valid for machines with a moveable photocell) .....	9
Card Stock and Extra Stiff Forms ....	9
Machines with Switch for the Photocell	10
Setting of the Switch .....	10
Setting of the Stacker Tray .....	10
Changing the Ribbon .....	11
Changing the Plastic Ribbon Shield ...	12
Changing the Print Band .....	12
Cleaning the Print Area .....	14
Cleaning the Print Band and Front Unit	15
Cleaning the Plastic Ribbon Shield ...	15
Error Indications and Operator Actions	16

### Fourth Edition (July 1986)

Changes or additions to the text or illustrations are indicated by a vertical bar to the left of the change.

This reference summary contains information from the *IBM 4245 Printer Models 12 and 20 Information Manual*, GA33-1579. This summary may be updated from time to time; however, the basic document is the authoritative source and will be the first to reflect changes.

It is possible that this material may contain reference to, or information about, IBM products (machines and programs), programming, or services that are not announced in your country. Such references or information must not be construed to mean that IBM intends to announce such IBM products, programming, or services in your country.

Address comments concerning this publication to the address below. IBM may use or distribute any of the information you supply in any way it believes appropriate without incurring any obligation whatever. You may, of course, continue to use the information you supply.

IBM Laboratories  
Dept. 3263, Printer Information Development  
Schoenaicher Strasse 220  
D-7030 Boeblingen, Federal Republic of Germany

## Unit Emergency Switch

Turns off input power to printer immediately.  
To be used in emergencies only.  
Also serves as over-current protector.

## Front Operator Panel

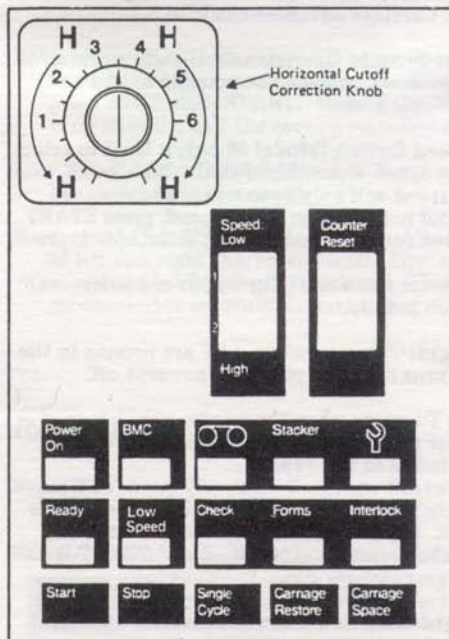

Model 20

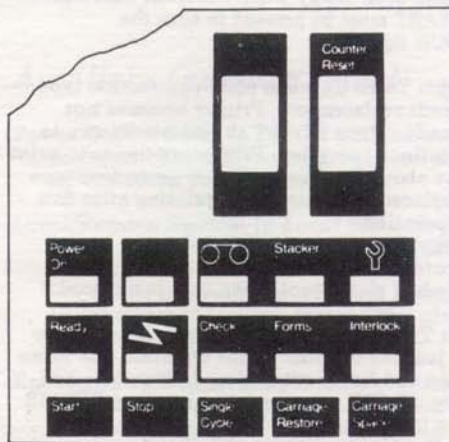

Model 12

**Start Key:** Makes printer ready. Generates *check reset* to turn off check lights.



**Stop Key:** Makes printer **not ready**. Activates ribbon drive if front unit is open (as long as key is pressed).

**Single Cycle Key:** Operational only when printer is not ready. Prints a single line each time the key is pressed. Press START to return to normal operation.

**Carriage Restore Key:** Operational only when printer is not ready. Causes forms carriage to advance to channel 1 and stop.

**Carriage Space Key:** Operational only when printer is not ready. Carriage advances one line.

**Counter Reset Switch:** Operational only when printer is not ready. Resets carriage line counter to line 1 without moving forms.

**High/Low Speed Switch (Model 20 only):** Used to select high or low speed. Operational at any time, but a change of speed will only be executed if:

- Print band not running: Select speed, press START.
- Print band running: Press STOP, select speed, press START.

Do **not** operate this switch during job execution, wait until the job is done.

**Power On Light:** Turns **on** when +5V are present in the printer. Turns **off** when printer is powered off.

**Ready Light:** Turns **on** when the printer switches to ready (after pressing START). Turns **off** when the printer switches to **not ready**.

**Stacker Light:** Turns **on** when stacker is full or stacker jam occurs. Printer becomes **not ready**. Turns **off** when the check condition is settled and START is pressed.

**Interlock Light:** Turns **on** when front unit is opened. Turns **off** when front unit is closed. If printer had been **ready** when the front unit was opened, START must be pressed to turn the INTERLOCK light off.

**Call CSR Light:** Turns **on** when platen-protection tape needs replacement. Printer becomes **not ready**. Press START at first occurrence to continue operation. Printer continues to print for about five hours. Platen-protection tape must be replaced or printer stops printing after five hours of operation.

**Call service representative to replace platen-protection tape.**

Turns **off** when platen-protection tape is replaced.

**Forms Light:** Turns **on** when end of forms is sensed, or forms are jammed or torn. Turns **off** when new forms are inserted and front unit is closed. If printer had been **ready**, START must be pressed to turn FORMS light off.

**Check Light:** Turns **on** when control unit detects an error (carriage check, hammer check, print band synchronization check, controller check, data check, buffer load check). Printer becomes **not ready** (except for data check or buffer load check). Turns **off** when error is corrected and START is pressed.

**Ribbon Check Light:** Turns **on** when ribbon moves too far left. Usually indicates ribbon needs replacing. Turns **off** when ribbon is turned over or replaced. If printer had been **ready**, START must be pressed to turn RIBBON CHECK light off.



**BMC Light (Model 20 only):** Turns **on** when the print band drive does not work properly. When flashing, press STOP, then START. If the light flashes again or is on steadily, call the service representative.

**Low Speed Light (Model 20 only):** Turns **on** when printer has switched to low speed.

**Horizontal Cutoff Correction Knob:** Allows correction of left and right character cutoff. Low setting is recommended for single-part forms. High setting is recommended for multiple-part forms.

## Rear Operator Panel

Start Key, Stop Key, and Carriage Restore Key are duplicates of the respective front operator panel keys.

**Stacker Down Key:** Operational only when printer is **not ready**. Lowers stacker tray as long as key is pressed or lowest position is reached. (Upward motion is manual operation.)



## Auxiliary Operator Panel

**Power On/Off Switch:** The ON position switches printer power **on**. The OFF position switches printer power **off** and resets power checks.

**Local/Remote Switch:** In **Local** position, printer power is turned on and off by the printer POWER ON/OFF switch.

In **Remote** position, printer power is turned on and off by the attached system. Power **off** is always possible with printer POWER ON/OFF switch.

**Enable/Disable Switch:** In **Enable** position, printer is enabled to the channel. In **Disable** position, printer is disabled from channel and the DISABLE light is **on**.

**Byte/Burst Switch:** In **Byte** position, printer operates in byte mode. In **Burst** position, printer operates in burst mode. For MPX channel only.



**Reset Switch:** Resets printer and all printer error conditions. Printer becomes **not ready**. Forms control buffer is loaded with default data.

**Power Indicator:** Turns **on** when power up sequence is started. Turns **off** when power down sequence ends.

**Disable Indicator:** Turns **on** when ENABLE/DISABLE switch is in **Disable** position. Turns **off** when ENABLE/DISABLE switch is in **Enable** position.

**Power Check Indicators:** These five LEDs indicate a power failure or a thermal check. Refer to the label on the inner side of the forms compartment door. To reset a power check, switch power off at the auxiliary operator panel.

## Adjustment Knobs

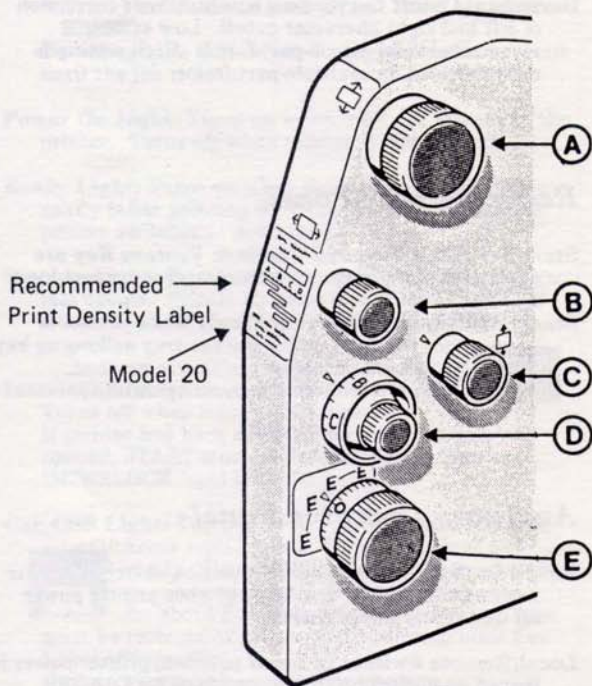

**Forms Advance Knob (A):** Moves forms vertically. Printer must be **not ready**.

**Horizontal Print Adjustment Knob (B):** Allows fine lateral adjustment of forms. Range of adjustment 12.7 mm (0.5 in.).

**Vertical Print Registration Knob (C):** Allows fine vertical adjustment of forms at print line. Range of adjustment 3 mm (0.12 in.).

**Print Density Knob (D):** Regulates hammer impact on ribbon and forms.

Setting A - High energy = High print density  
Setting D - Low energy = Low print density

- **Single-Part Forms:**  
Set knob to D or between D and C with new ribbon.  
Turn toward C or slightly further with old ribbon.
- **Multiple-Part Forms:** Set knob to B or A and check for density on last part of multiple-part forms.
- **General**  
*Low density = Low ink consumption = Long ribbon life*  
*High density = High ink consumption = Short ribbon life*

See label "Recommended Print Density".

*Note: Print density may be impacted by forms variation, environmental changes, or age of the ribbon.*

**Light Top/Bottom Knob (E):** Allows correction of light tops or bottoms.

Turn knob according to symbols on the label:

- For light tops: Turn clockwise from symbol 'light tops' towards the upper good E.
- For light bottoms: Turn counterclockwise from symbol 'light bottoms' towards the lower good E.

## Initial Forms Loading

1. Press STOP and raise the top cover.
  2. Open front unit and forms compartment door. Put forms into compartment, pull up top of forms, fit leading forms onto tractors, and close tractor covers.
  3. Set 'vertical print registration' knob to position 0. Turn 'horizontal print adjustment' knob until middle ring (A) on shaft is just visible to the left of the housing.
  4. Close ribbon shield (B). Lift tractor levers (C) and align forms with hammer position indicator scale (D) according to job instructions. Horizontal print adjustment knob gives fine adjustment.
- Note: For small forms, at least one of the end-of-forms fingers must be covered by the forms.*
5. Open ribbon shield (B). Turn 'forms advance' knob until perforation between first and second sheet aligns with top of red line (E).



- Operate Counter Reset switch. Forms are now synchronized. Close front unit and press START.

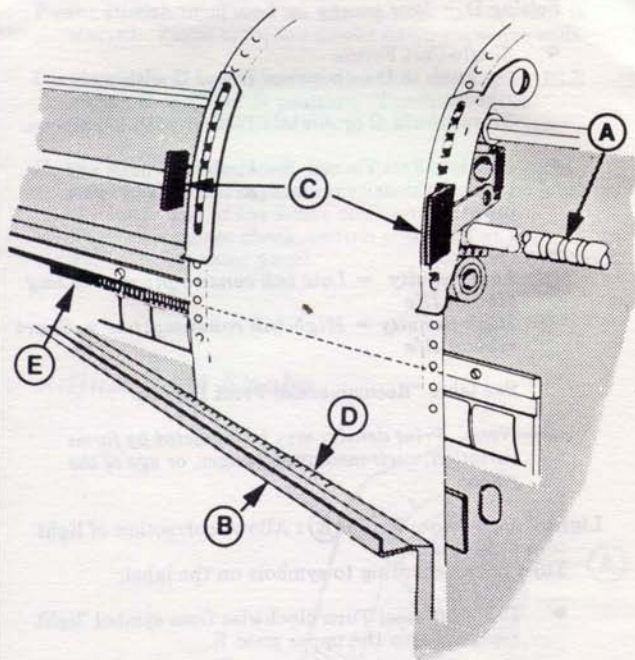

### Starting First Job

For OCR printing refer to IBM 4245 Printer Models 12 and 20 Information Manual, GA33-1579.

- Set print density as recommended (see "Adjustment Knobs").  
*Note: Print density may be impacted by forms variation, environmental changes, or age of the ribbon.*
- Press START (print band character set is loaded automatically).
- Load forms control buffer if not done automatically by system.
- Press STOP.
- Press SINGLE CYCLE to print a single line. Open the front unit, check print density, and examine registration. If print is badly aligned, adjust forms with 'vertical print registration' knob and 'horizontal print adjustment' knob. Close front unit and press START to continue.
- Guide the first few forms onto stacker tray.
- Close top cover.

### Removing Forms at End of Job

- Press STOP.
- Press CARRIAGE RESTORE or CARRIAGE SPACE to move the last printed form above the tractors.
- Tear off forms below last printed sheet.
- Press CARRIAGE SPACE to unload forms.
- Remove job from stacker.

### Reloading Forms of Same Type

- Raise top cover and open forms compartment door. Replenish forms and open front unit.
- Open tractor covers and place new forms over previous forms so that perforations between sheets match exactly.
- Do not touch any switches or knobs. Close tractor covers and front unit. Press START.
- Guide the first few forms onto stacker tray.
- Check print density, readjust if necessary.



## Adjustable Stacker

**Front paper guide (A)**: Six positions, defined by six numbered holes in guide holder (B).

**Paper rail (C)**: Three settings: high, middle, and low. In low setting, paper rail is positioned below stacker tray (D). In middle and high settings, notches are engaged in holding rod (E) of tray.

**Rear paper guide (F)**: 13 positions, defined by numbered holes in guide holder (G).

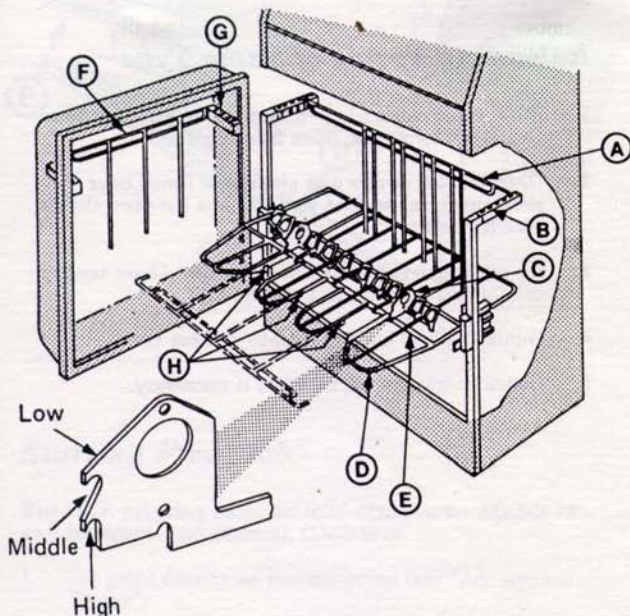

## Stacker Adjustment

### Machines with fixed or moveable Photocell

#### Forms up to 356 mm (14 in.) long

1. Press STACKER DOWN until stacker tray (D) is clear of guides.
2. Set guides (A) and (F) according to length of form.
3. Set paper rail (C) to level shown in table.
4. Manually raise stacker tray (D) to top position.

Forms	Rail
1 part, card stock, extra stiff forms, and forms over 356mm (14 in.) long	Low
2 to 4 parts	Middle
More than 4 parts	High

#### Forms longer than 356 mm (14 in.)

1. Press STACKER DOWN until stacker tray (D) is clear of guides.
2. Place front paper guide (A) in holes marked 14.
3. Remove paper guide (F) from holder (G) and slide it into three tubes (H) of stacker tray (D).
4. Manually raise stacker tray to middle position.
5. Set paper rail (C) to the levels shown in table.

### Lever/Indicator Photocell (only valid for machines with a moveable photocell)

Should be in its upper position for normal stacking. For stacking 6-part forms, setting in lower position is recommended (before setting: move stacker tray down, after setting: move stacker tray up again).

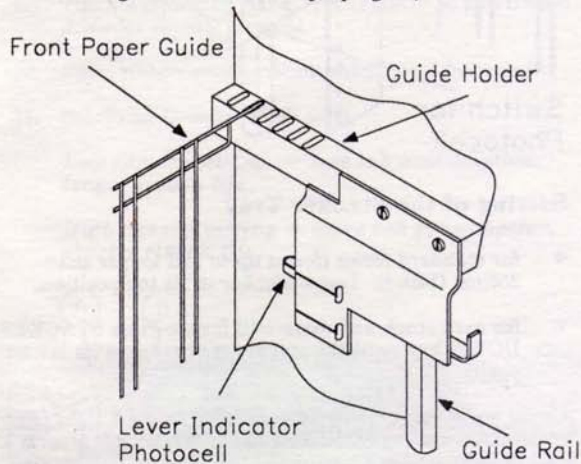

### Card Stock and Extra Stiff Forms

1. Press STACKER DOWN until tray (D) reaches its bottom position.
2. Position paper guides (A) and (F) according to distance between major folds of card stock.
3. Set paper rail (C) to 'low' position.

Multiple part forms must be crimped securely. For details, see *IBM 4245 Printer Models 12 and 20 Information Manual*, GA33-1579.



## Machines with Switch for the Photocell

Settings of paper rail, front and rear paper guides as before.

### Setting of the Switch

- for 1 to 4 part forms: upper position
- for more than 4 part forms: lower position
- for forms longer than 356mm (14in.): lower position

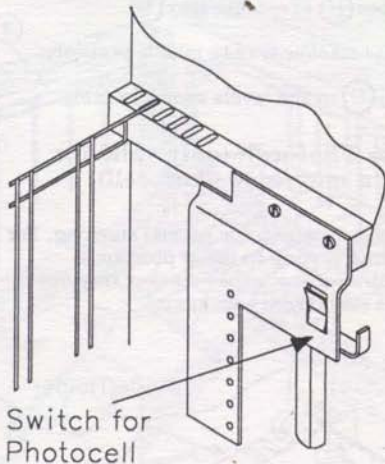

### Setting of the Stacker Tray

- for standard forms (forms up to and longer than 356mm (14in.)): Leave stacker in its top position.
- for card stock and extra stiff forms: Press STACKER DOWN key until the stacker tray reaches its lowest position.

Under some specific conditions the STACKER light might turn on. For more details see *IBM 4245 Printer Models 12 and 20 Information Manual*, GA33-1579.

## Changing the Ribbon

1. Press STOP and raise top cover. Open front unit and wait for print band to stop.
2. Open ribbon shield. Swing down ribbon cover.
3. Push bottom ribbon spool towards hinged side of front unit. Lift out other end of bottom spool. Remove bottom spool and place it in ribbon cover.
4. Push top ribbon spool towards hinged side of front unit and lift out other end of spool. Discard old ribbon.
5. Vacuum print area, see "Cleaning the Print Area", steps 2 to 5.
6. Insert empty spool of new ribbon on top by pushing spool onto ribbon drive cone at hinged end of front unit. Align spool with other cone and allow ribbon spool to seat on cone. Top ribbon spool is now held by the two drive cones.
7. Install full ribbon spool on bottom drive cones in same way.
8. Make sure that reversing bar (A) on top ribbon spool is on spool side of trip lever (B).
9. Tighten ribbon by hand. Press STOP to run ribbon drive for several seconds.
10. Close ribbon cover, ribbon shield, and front unit.
11. Set 'Print Density' knob to D.

*Low density setting = less ink consumption, longer ribbon life.*

*High density setting = more ink consumption, shorter ribbon life.*

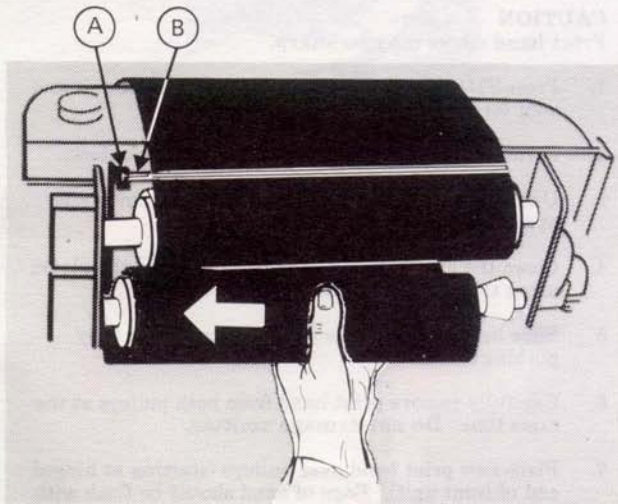



## Changing the Plastic Ribbon Shield

1. Open front unit and ribbon shield.
2. Use a coin to disengage plastic ribbon shield latch, and pull out plastic ribbon shield.
3. Install new plastic ribbon shield (P/N 4012176; for U.S. only: P/N 6092766). Ensure that the shield stiffener enters the slot properly and stays in the slot for the full length of the plastic ribbon shield. See enlarged view.
4. Ensure that latch engages properly.
5. Close ribbon shield and front unit.

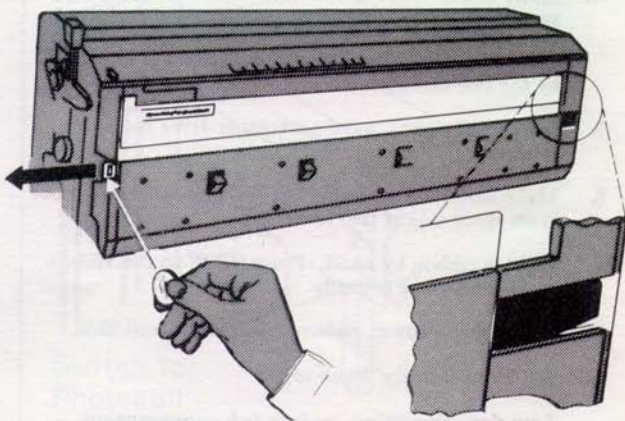

## Changing the Print Band

### CAUTION

Print band edges may be sharp.

1. Press STOP and raise top cover. Open front unit and wait for print band to stop.
2. Perform steps 2 and 3 of ribbon change procedure.
3. Unscrew knurled knob (A) on print band cover and open cover.
4. Clean the area between the print band and the platen using the vacuum cleaner.
5. Slide band-tension lever (B) to left and lock it by pushing down.
6. Carefully remove print band from both pulleys at the same time. Do not damage emitter.
7. Place new print band over pulleys (starting at hinged end of front unit). Edge of band should be flush with

top of pulleys. Make sure the print band is right side up (timing marks at the bottom edge of the band).

8. Unlock band-tension lever (B) and spin pulley with one finger until band rests on both guide rollers.
9. Close print band cover and tighten knurled knob (A).
10. Reinstall ribbon spool and close ribbon cover, ribbon shield, and front unit.

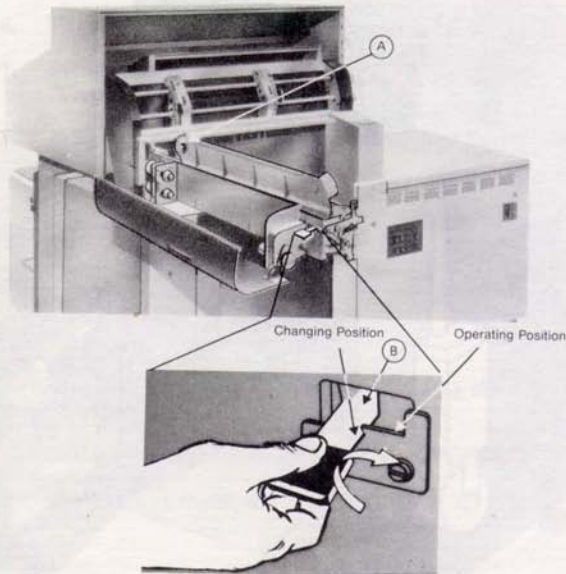

## Cleaning the Print Area

Check waste container weekly. Replace filter bag, if necessary.

1. Raise top cover, open front unit and forms compartment door totally, and remove forms.
2. Attach vacuum hose to vacuum tube at hinge side of front unit (vacuum cleaner starts automatically).
3. Vacuum all lint and dirt from print area (including under ribbon cover, under print band cover, paper brakes, and hammers).
4. Clean paper compartment, if necessary.
5. Disconnect vacuum hose and store it in forms compartment door.

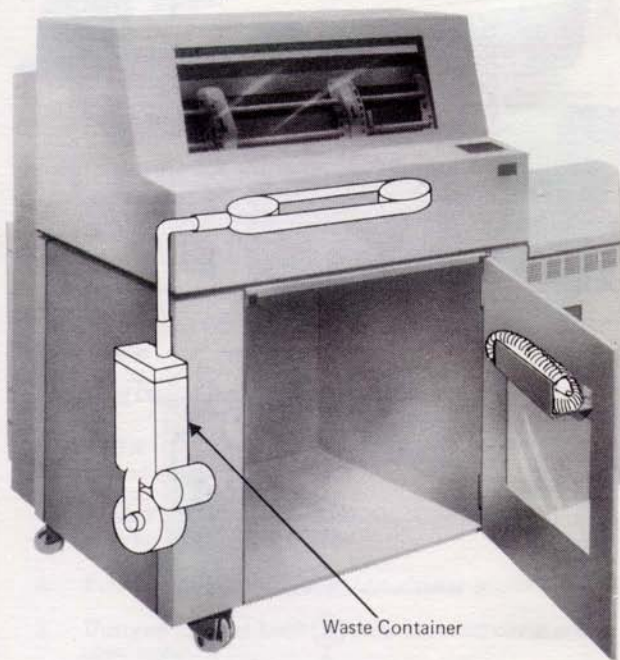

Regularly empty waste container. Waste container is under left side cover. Spare filter bags are inside left side cover.

## Cleaning the Print Band and Front Unit

### CAUTION

Print band edges may be sharp.

1. Open front unit and wait for print band to stop.
2. Remove bottom ribbon spool (perform steps 2 and 3 of "Changing the Ribbon").
3. Remove print band (perform steps 3, 4, and 5 of "Changing the Print Band"). Unscrew knurled knob on print band cover and open cover.
4. Clean print band using brush provided in pocket in left side cover, denatured alcohol, and a cleaning tissue. Do *not* clean the rear side of the print band with any cleaning fluid.
5. Clean band pulleys and band area. Clean ribbon shield and ribbon guides with denatured alcohol and a cleaning tissue, if necessary.
6. Vacuum print area (see "Cleaning the Print Area").
7. Reinstall print band (perform steps 6, 7, and 8 of "Changing the Print Band").
8. Reinstall bottom ribbon spool and close ribbon cover, ribbon shield, and front unit.

## Cleaning the Plastic Ribbon Shield

1. Remove plastic ribbon shield.
2. Clean plastic ribbon shield using cleaning tissue and denatured alcohol.
3. Reinstall plastic ribbon shield.
4. Close ribbon shield and front unit.



## ***Error Indications and Operator Actions***

<b>Error Indication</b>	<b>Operator Action</b>
RIBBON CHECK Light	Replace ribbon. Press START.
STACKER Light	Empty stacker or remove stacker jam. Press START.
CALL CSR Light	Call service representative to replace platen protection tape. Press START.
CHECK Light	Determine error condition and take appropriate corrective action. Press START.
FORMS Light	Replace forms or clear forms jam. Press START.
INTERLOCK Light	Close front unit. Press START.
BMC Light	Flashing, press STOP and START.  Steadily on or flashing again, call service representative.
No reaction to key depression (hang condition)	Press RESET at auxiliary operator panel.

This page has been intentionally left blank.

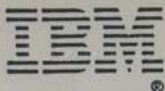

GX33-1508-3  
(File No. S370/4300-03)  
Printed in U.S.A.

GX33-1508-03

