

# IBM Maintenance Library

3803-2/ 3420 S/N	3803-2/ 3420 S/N	3803-2/ 3420 S/N	3803-2/ 3420 S/N
<b>MLM</b>	<b>MLM</b>	<b>MLM</b>	<b>MLM</b>
PLAN	INTF	MAP	OPER
START	07-000	16-000	40-000
SENSE	CARR	21-XXX	58-XXX
MAP	08-000		REF
00-000	MAP		75-001
1A-000	11-000		85-XXX
6A-XXX	15-XXX		INST
1B-000			90-000
6B-XXX			<b>INDEX</b>
<b>VOL. 1</b>	<b>VOL. 2</b>	<b>VOL. 3</b>	<b>VOL. 4</b>



# 3803-2 / 3420

## Magnetic Tape Subsystem Maintenance Manual

3803-2/3420

AA000A	4169434	See EC	845958				
Seq 1 of 2	Part Number	History	1 Sep 79				

# SAFETY

## PERSONAL

The importance of personal safety cannot be overemphasized. To ensure personal safety and the safety of co-workers, follow established safety practices and procedures at all times.

Look for and obey the DANGER notices found in the maintenance documentation. All CEs must be familiar with the general safety practices and the procedures for artificial respiration outlined in IBM Form 229-1264. For convenience, this form is duplicated to the right.

## MACHINE

To protect machines from damage, turn off power before removing or inserting circuit cards of components. Do not leave internal machine areas needlessly exposed, avoid shorting panel pins when scoping, and handle machine parts carefully. In addition, look for and observe the CAUTION notices found in maintenance documentation.

A form for reader's comments is provided at the front of this publication. If the form has been removed, send your comments to the address below.

This manual was prepared by the IBM General Products Division, Department 21H, Boulder, Colorado 80302.

## CE SAFETY PRACTICES

All Customer Engineers are expected to take every safety precaution possible and observe the following safety practices while maintaining IBM equipment:

1. You should not work alone under hazardous conditions or around equipment with dangerous voltage. Always advise your manager if you MUST work alone.
2. Remove all power, ac and dc, when removing or assembling major components, working in immediate areas of power supplies, performing mechanical inspection of power supplies, or installing changes in machine circuitry.
3. After turning off wall box power switch, lock it in the Off position or tag it with a "Do Not Operate" tag, Form 229-1266. Pull power supply cord whenever possible.
4. When it is absolutely necessary to work on equipment having exposed operating mechanical parts or exposed live electrical circuitry anywhere in the machine, observe the following precautions:
  - a. Another person familiar with power off controls must be in immediate vicinity.
  - b. Do not wear rings, wrist watches, chains, bracelets, or metal cuff links.
  - c. Use only insulated pliers and screwdrivers.
  - d. Keep one hand in pocket.
  - e. When using test instruments, be certain that controls are set correctly and that insulated probes of proper capacity are used.
  - f. Avoid contacting ground potential (metal floor strips, machine frames, etc.). Use suitable rubber mats, purchased locally if necessary.
5. Wear safety glasses when:
  - a. Using a hammer to drive pins, riveting, staking, etc.
  - b. Power or hand drilling, reaming, grinding, etc.
  - c. Using spring hooks, attaching springs.
  - d. Soldering, wire cutting, removing steel bands.
  - e. Cleaning parts with solvents, sprays, cleaners, chemicals, etc.
  - f. Performing any other work that may be hazardous to your eyes. REMEMBER - THEY ARE YOUR EYES.
6. Follow special safety instructions when performing specialized tasks, such as handling cathode ray tubes and extremely high voltages. These instructions are outlined in CEMs and the safety portion of the maintenance manuals.
7. Do not use solvents, chemicals, greases, or oils that have not been approved by IBM.
8. Avoid using tools or test equipment that have not been approved by IBM.
9. Replace worn or broken tools and test equipment.
10. Lift by standing or pushing up with stronger leg muscles - this takes strain off back muscles. Do not lift any equipment or parts weighing over 60 pounds.
11. After maintenance, restore all safety devices, such as guards, shields, signs, and grounding wires.
12. Each Customer Engineer is responsible to be certain that no action on his part renders products unsafe or exposes customer personnel to hazards.
13. Place removed machine covers in a safe out-of-the-way place where no one can trip over them.
14. Ensure that all machine covers are in place before returning machine to customer.
15. Always place CE tool kit away from walk areas where no one can trip over it; for example, under desk or table.

16. Avoid touching moving mechanical parts when lubricating, checking for play, etc.
17. When using stroboscope, do not touch ANYTHING - it may be moving.
18. Avoid wearing loose clothing that may be caught in machinery. Shirt sleeves must be left buttoned or rolled above the elbow.
19. Ties must be tucked in shirt or have a tie clasp (preferably nonconductive) approximately 3 inches from end. Tie chains are not recommended.
20. Before starting equipment, make certain fellow CEs and customer personnel are not in a hazardous position.
21. Maintain good housekeeping in area of machine while performing and after completing maintenance.

**Knowing safety rules is not enough.  
An unsafe act will inevitably lead to an accident.  
Use good judgment - eliminate unsafe acts.**

## ARTIFICIAL RESPIRATION

### General Considerations

1. Start Immediately - Seconds Count  
Do not move victim unless absolutely necessary to remove from danger. Do not wait or look for help or stop to loosen clothing, warm the victim, or apply stimulants.
2. Check Mouth for Obstructions  
Remove foreign objects. Pull tongue forward.
3. Loosen Clothing - Keep Victim Warm  
Take care of these items after victim is breathing by himself or when help is available.
4. Remain in Position  
After victim revives, be ready to resume respiration if necessary.
5. Call a Doctor  
Have someone summon medical aid.
6. Don't Give Up  
Continue without interruption until victim is breathing without help or is certainly dead.

### Rescue Breathing for Adults

1. Place victim on his back immediately.
2. Clear throat of water, food, or foreign matter.
3. Tilt head back to open air passage.
4. Lift jaw up to keep tongue out of air passage.
5. Pinch nostrils to prevent air leakage when you blow.
6. Blow until you see chest rise.
7. Remove your lips and allow lungs to empty.
8. Listen for snoring and gurglings - signs of throat obstruction.
9. Repeat mouth to mouth breathing 10-20 times a minute. Continue rescue breathing until victim breathes for himself.



Thumb and finger positions



Final mouth-to-mouth position

3803-2/3420

AA000A	4169434	See EC	845958						
Seq 2 of 2	Part Number	History	1 Sep 79						

© Copyright International Business Machines Corporation 1976, 1979

**Reader's Comment Form**

This form may be used to communicate your views about this publication. They will be sent to the author's department for whatever review and action, if any, is deemed appropriate. Comments may be written in your own language; use of English is not required.

IBM shall have the nonexclusive right, in its discretion, to use and distribute all submitted information, in any form, for any and all purposes, without obligation of any kind to the submitter. Your interest is appreciated.

**Note:** Copies of IBM publications are not stocked at the location to which this form is addressed. Please direct any requests for copies of publications, or for assistance in using your IBM system, to your IBM representative or to the IBM branch office serving your locality.

Mach Type/Mod	Serial Number	Storage Control/CPU	MIM Page ID	MIM Page EC No.
Symptom/Error Code <span style="float: right;">If no error or symptom code, check here <input type="checkbox"/></span>				

Describe the trouble as it was reported to you, or as it appeared to you (machine problem).

Describe problem you encountered with documentation.

**Want an acknowledgement?**  
**Fill in your name and Branch Office Number:**  
 Name \_\_\_\_\_  
 B/O No. \_\_\_\_\_  
 Occupation \_\_\_\_\_

**For plant use only**  
 Date received \_\_\_\_\_  
 Sender acknowledged \_\_\_\_\_  
 Research completed \_\_\_\_\_  
 Incorporated by EC \_\_\_\_\_

Thank you for your cooperation. No postage stamp necessary if mailed in the U.S.A. (Elsewhere, an IBM office or representative will be happy to forward your comments.)

3803-2/3420

AA0010	4169693	443804	845958	846927				
Seq 1 of 8	Part Number	29 Oct 76	1 Sep 79	20 Jun 80				

This form may be used to communicate your views about this publication. They will be sent to the author's department for whatever review and action, if any, is deemed appropriate. Comments may be written in your own language; use of English is not required.

IBM shall have the nonexclusive right, in its discretion, to use and distribute all submitted information, in any form, for any and all purposes, without obligation of any kind to the submitter. Your interest is appreciated.

**Note:** Copies of IBM publications are not stocked at the location to which this form is addressed. Please direct any requests for copies of publications, or for assistance in using your IBM system, to your IBM representative or to the IBM branch office serving your locality.

Mach Type/Mod	Serial Number	Storage Control/CPU	MIM Page ID	MIM Page EC No.
Symptom/Error Code <span style="float: right;">If no error or symptom code, check here <input type="checkbox"/></span>				

Describe the trouble as it was reported to you, or as it appeared to you (machine problem).

Describe problem you encountered with documentation.

**Want an acknowledgement?**  
**Fill in your name and Branch Office Number:**  
 Name \_\_\_\_\_  
 B/O No. \_\_\_\_\_  
 Occupation \_\_\_\_\_

**For plant use only**  
 Date received \_\_\_\_\_  
 Sender acknowledged \_\_\_\_\_  
 Research completed \_\_\_\_\_  
 Incorporated by EC \_\_\_\_\_

Thank you for your cooperation. No postage stamp necessary if mailed in the U.S.A. (Elsewhere, an IBM office or representative will be happy to forward your comments.)

Reader's Comment Form

Fold and tape

Please Do Not Staple

Fold and tape

Attention: Device Product Engineering  
Department 64P



NO POSTAGE  
NECESSARY IF  
MAILED IN THE  
UNITED STATES

**BUSINESS REPLY MAIL**

FIRST CLASS PERMIT NO. 40 ARMONK, NEW YORK

POSTAGE WILL BE PAID BY ADDRESSEE

International Business Machines Corporation  
General Products Division  
P. O. Box 27155  
Tucson, Arizona 85726

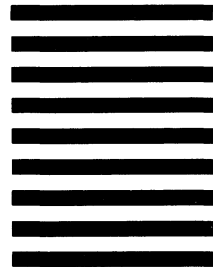

Fold and tape

Please Do Not Staple

Fold and tape



International Business Machines Corporation  
Data Processing Division  
1133 Westchester Avenue, White Plains, N.Y. 10604

IBM World Trade Americas/Far East Corporation  
Town of Mount Pleasant, Route 9, North Tarrytown, N.Y., U.S.A. 10591

IBM World Trade Europe/Middle East/Africa Corporation  
360 Hamilton Avenue, White Plains, N.Y., U.S.A. 10601

3803-2/3420

AA0010	4169693	443804	845958	846927				
Seq 2 of 8	Part Number	29 Oct 76	1 Sep 79	20 Jun 80				

© Copyright International Business Machines Corporation 1976, 1979, 1980

Reader's Comment Form

Fold and tape

Please Do Not Staple

Fold and tape

Attention: Device Product Engineering  
Department 64P

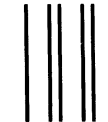

NO POSTAGE  
NECESSARY IF  
MAILED IN THE  
UNITED STATES

**BUSINESS REPLY MAIL**

FIRST CLASS PERMIT NO. 40 ARMONK, NEW YORK

POSTAGE WILL BE PAID BY ADDRESSEE

International Business Machines Corporation  
General Products Division  
P. O. Box 27155  
Tucson, Arizona 85726

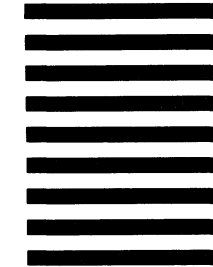

Fold and tape

Please Do Not Staple

Fold and tape



International Business Machines Corporation  
Data Processing Division  
1133 Westchester Avenue, White Plains, N.Y. 10604

IBM World Trade Americas/Far East Corporation  
Town of Mount Pleasant, Route 9, North Tarrytown, N.Y., U.S.A. 10591

IBM World Trade Europe/Middle East/Africa Corporation  
360 Hamilton Avenue, White Plains, N.Y., U.S.A. 10601



**Reader's Comment Form**

This form may be used to communicate your views about this publication. They will be sent to the author's department for whatever review and action, if any, is deemed appropriate. Comments may be written in your own language; use of English is not required.

IBM shall have the nonexclusive right, in its discretion, to use and distribute all submitted information, in any form, for any and all purposes, without obligation of any kind to the submitter. Your interest is appreciated.

**Note:** Copies of IBM publications are not stocked at the location to which this form is addressed. Please direct any requests for copies of publications, or for assistance in using your IBM system, to your IBM representative or to the IBM branch office serving your locality.

Mach Type/Mod	Serial Number	Storage Control/CPU	MIM Page ID	MIM Page EC No.
Symptom/Error Code <span style="float: right;">If no error or symptom code, check here <input type="checkbox"/></span>				

Describe the trouble as it was reported to you, or as it appeared to you (machine problem).

Describe problem you encountered with documentation.

**Want an acknowledgement?**  
**Fill in your name and Branch Office Number:**  
 Name \_\_\_\_\_  
 B/O No. \_\_\_\_\_  
 Occupation \_\_\_\_\_

**For plant use only**  
 Date received \_\_\_\_\_  
 Sender acknowledged \_\_\_\_\_  
 Research completed \_\_\_\_\_  
 Incorporated by EC \_\_\_\_\_

Thank you for your cooperation. No postage stamp necessary if mailed in the U.S.A. (Elsewhere, an IBM office or representative will be happy to forward your comments.)

3803-2/3420

AA0010	4169693	443804	845958	846927				
Seq 3 of 8	Part Number	29 Oct 76	1 Sep 79	20 Jun 80				

This form may be used to communicate your views about this publication. They will be sent to the author's department for whatever review and action, if any, is deemed appropriate. Comments may be written in your own language; use of English is not required.

IBM shall have the nonexclusive right, in its discretion, to use and distribute all submitted information, in any form, for any and all purposes, without obligation of any kind to the submitter. Your interest is appreciated.

**Note:** Copies of IBM publications are not stocked at the location to which this form is addressed. Please direct any requests for copies of publications, or for assistance in using your IBM system, to your IBM representative or to the IBM branch office serving your locality.

Mach Type/Mod	Serial Number	Storage Control/CPU	MIM Page ID	MIM Page EC No.
Symptom/Error Code <span style="float: right;">If no error or symptom code, check here <input type="checkbox"/></span>				

Describe the trouble as it was reported to you, or as it appeared to you (machine problem).

Describe problem you encountered with documentation.

**Want an acknowledgement?**  
**Fill in your name and Branch Office Number:**  
 Name \_\_\_\_\_  
 B/O No. \_\_\_\_\_  
 Occupation \_\_\_\_\_

**For plant use only**  
 Date received \_\_\_\_\_  
 Sender acknowledged \_\_\_\_\_  
 Research completed \_\_\_\_\_  
 Incorporated by EC \_\_\_\_\_

Thank you for your cooperation. No postage stamp necessary if mailed in the U.S.A. (Elsewhere, an IBM office or representative will be happy to forward your comments.)

Reader's Comment Form

Fold and tape

Please Do Not Staple

Fold and tape

Attention: Device Product Engineering  
Department 64P

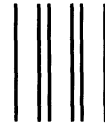

NO POSTAGE  
NECESSARY IF  
MAILED IN THE  
UNITED STATES

**BUSINESS REPLY MAIL**

FIRST CLASS PERMIT NO. 40 ARMONK, NEW YORK

POSTAGE WILL BE PAID BY ADDRESSEE

International Business Machines Corporation  
General Products Division  
P. O. Box 27155  
Tucson, Arizona 85726

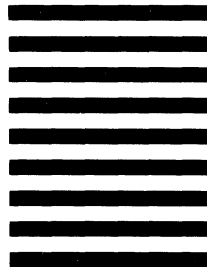

Fold and tape

Please Do Not Staple

Fold and tape



International Business Machines Corporation  
Data Processing Division  
1133 Westchester Avenue, White Plains, N.Y. 10604

IBM World Trade Americas/Far East Corporation  
Town of Mount Pleasant, Route 9, North Tarrytown, N.Y., U.S.A. 10591

IBM World Trade Europe/Middle East/Africa Corporation  
360 Hamilton Avenue, White Plains, N.Y., U.S.A. 10601

3803-2/3420

AA0010	4169693	443804	845958	846927				
Seq 4 of 8	Part Number	29 Oct 76	1 Sep 79	20 Jun 80				

© Copyright International Business Machines Corporation 1976, 1979, 1980

Reader's Comment Form

Fold and tape

Please Do Not Staple

Fold and tape

Attention: Device Product Engineering  
Department 64P

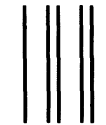

NO POSTAGE  
NECESSARY IF  
MAILED IN THE  
UNITED STATES

**BUSINESS REPLY MAIL**

FIRST CLASS PERMIT NO. 40 ARMONK, NEW YORK

POSTAGE WILL BE PAID BY ADDRESSEE

International Business Machines Corporation  
General Products Division  
P. O. Box 27155  
Tucson, Arizona 85726

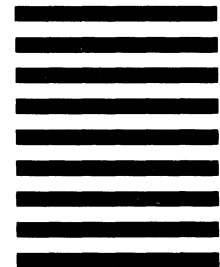

Fold and tape

Please Do Not Staple

Fold and tape



International Business Machines Corporation  
Data Processing Division  
1133 Westchester Avenue, White Plains, N.Y. 10604

IBM World Trade Americas/Far East Corporation  
Town of Mount Pleasant, Route 9, North Tarrytown, N.Y., U.S.A. 10591

IBM World Trade Europe/Middle East/Africa Corporation  
360 Hamilton Avenue, White Plains, N.Y., U.S.A. 10601



**Reader's Comment Form**

This form may be used to communicate your views about this publication. They will be sent to the author's department for whatever review and action, if any, is deemed appropriate. Comments may be written in your own language; use of English is not required.

IBM shall have the nonexclusive right, in its discretion, to use and distribute all submitted information, in any form, for any and all purposes, without obligation of any kind to the submitter. Your interest is appreciated.

**Note:** Copies of IBM publications are not stocked at the location to which this form is addressed. Please direct any requests for copies of publications, or for assistance in using your IBM system, to your IBM representative or to the IBM branch office serving your locality.

Mach Type/Mod	Serial Number	Storage Control/CPU	MIM Page ID	MIM Page EC No.
Symptom/Error Code <span style="float: right;">If no error or symptom code, check here <input type="checkbox"/></span>				

Describe the trouble as it was reported to you, or as it appeared to you (machine problem).

Describe problem you encountered with documentation.

<p><b>Want an acknowledgement?</b></p> <p><b>Fill in your name and Branch Office Number:</b></p> <p>Name _____</p> <p>B/O No. _____</p> <p>Occupation _____</p>
---

<p><b>For plant use only</b></p> <p>Date received _____</p> <p>Sender acknowledged _____</p> <p>Research completed _____</p> <p>Incorporated by EC _____</p>
--

Thank you for your cooperation. No postage stamp necessary if mailed in the U.S.A. (Elsewhere, an IBM office or representative will be happy to forward your comments.)

3803-2/3420

AA0010	4169693	443804	845958	846927			
Seq 5 of 8	Part Number	29 Oct 76	1 Sep 79	20 Jun 80			

This form may be used to communicate your views about this publication. They will be sent to the author's department for whatever review and action, if any, is deemed appropriate. Comments may be written in your own language; use of English is not required.

IBM shall have the nonexclusive right, in its discretion, to use and distribute all submitted information, in any form, for any and all purposes, without obligation of any kind to the submitter. Your interest is appreciated.

**Note:** Copies of IBM publications are not stocked at the location to which this form is addressed. Please direct any requests for copies of publications, or for assistance in using your IBM system, to your IBM representative or to the IBM branch office serving your locality.

Mach Type/Mod	Serial Number	Storage Control/CPU	MIM Page ID	MIM Page EC No.
Symptom/Error Code <span style="float: right;">If no error or symptom code, check here <input type="checkbox"/></span>				

Describe the trouble as it was reported to you, or as it appeared to you (machine problem).

Describe problem you encountered with documentation.

<p><b>Want an acknowledgement?</b></p> <p><b>Fill in your name and Branch Office Number:</b></p> <p>Name _____</p> <p>B/O No. _____</p> <p>Occupation _____</p>
---

<p><b>For plant use only</b></p> <p>Date received _____</p> <p>Sender acknowledged _____</p> <p>Research completed _____</p> <p>Incorporated by EC _____</p>
--

Thank you for your cooperation. No postage stamp necessary if mailed in the U.S.A. (Elsewhere, an IBM office or representative will be happy to forward your comments.)

Reader's Comment Form

Fold and tape

Please Do Not Staple

Fold and tape

Attention: Device Product Engineering  
Department 64P



NO POSTAGE  
NECESSARY IF  
MAILED IN THE  
UNITED STATES

**BUSINESS REPLY MAIL**  
FIRST CLASS PERMIT NO. 40 ARMONK, NEW YORK

POSTAGE WILL BE PAID BY ADDRESSEE

International Business Machines Corporation  
General Products Division  
P. O. Box 27155  
Tucson, Arizona 85726

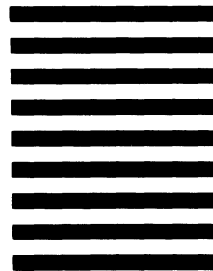

Fold and tape

Please Do Not Staple

Fold and tape



International Business Machines Corporation  
Data Processing Division  
1133 Westchester Avenue, White Plains, N.Y. 10604

IBM World Trade Americas/Far East Corporation  
Town of Mount Pleasant, Route 9, North Tarrytown, N.Y., U.S.A. 10591

IBM World Trade Europe/Middle East/Africa Corporation  
360 Hamilton Avenue, White Plains, N.Y., U.S.A. 10601

3803-2/3420

AA0010	4169693	443804	845958	846927				
Seq 6 of 8	Part Number	29 Oct 78	1 Sep 79	20 Jun 80				

© Copyright International Business Machines Corporation 1976, 1979, 1980

Reader's Comment Form

Fold and tape

Please Do Not Staple

Fold and tape

Attention: Device Product Engineering  
Department 64P

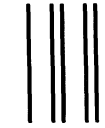

NO POSTAGE  
NECESSARY IF  
MAILED IN THE  
UNITED STATES

**BUSINESS REPLY MAIL**  
FIRST CLASS PERMIT NO. 40 ARMONK, NEW YORK

POSTAGE WILL BE PAID BY ADDRESSEE

International Business Machines Corporation  
General Products Division  
P. O. Box 27155  
Tucson, Arizona 85726

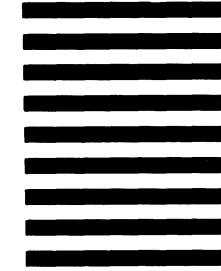

Fold and tape

Please Do Not Staple

Fold and tape



International Business Machines Corporation  
Data Processing Division  
1133 Westchester Avenue, White Plains, N.Y. 10604

IBM World Trade Americas/Far East Corporation  
Town of Mount Pleasant, Route 9, North Tarrytown, N.Y., U.S.A. 10591

IBM World Trade Europe/Middle East/Africa Corporation  
360 Hamilton Avenue, White Plains, N.Y., U.S.A. 10601





**Reader's Comment Form**

This form may be used to communicate your views about this publication. They will be sent to the author's department for whatever review and action, if any, is deemed appropriate. Comments may be written in your own language; use of English is not required.

IBM shall have the nonexclusive right, in its discretion, to use and distribute all submitted information, in any form, for any and all purposes, without obligation of any kind to the submitter. Your interest is appreciated.

**Note:** Copies of IBM publications are not stocked at the location to which this form is addressed. Please direct any requests for copies of publications, or for assistance in using your IBM system, to your IBM representative or to the IBM branch office serving your locality.

Mach Type/Mod	Serial Number	Storage Control/CPU	MIM Page ID	MIM Page EC No.
Symptom/Error Code <span style="float: right;">If no error or symptom code, check here <input type="checkbox"/></span>				

Describe the trouble as it was reported to you, or as it appeared to you (machine problem).

Describe problem you encountered with documentation.

<p><b>Want an acknowledgement?</b></p> <p>Fill in your name and Branch Office Number:</p> <p>Name _____</p> <p>B/O No. _____</p> <p>Occupation _____</p>
--

<p><b>For plant use only</b></p> <p>Date received _____</p> <p>Sender acknowledged _____</p> <p>Research completed _____</p> <p>Incorporated by EC _____</p>
--

Thank you for your cooperation. No postage stamp necessary if mailed in the U.S.A. (Elsewhere, an IBM office or representative will be happy to forward your comments.)

3803-2/3420

AA0010	4169693	443804	845958	846927				
Seq 7 of 8	Part Number	29 Oct 76	1 Sep 79	20 Jun 80				

This form may be used to communicate your views about this publication. They will be sent to the author's department for whatever review and action, if any, is deemed appropriate. Comments may be written in your own language; use of English is not required.

IBM shall have the nonexclusive right, in its discretion, to use and distribute all submitted information, in any form, for any and all purposes, without obligation of any kind to the submitter. Your interest is appreciated.

**Note:** Copies of IBM publications are not stocked at the location to which this form is addressed. Please direct any requests for copies of publications, or for assistance in using your IBM system, to your IBM representative or to the IBM branch office serving your locality.

Mach Type/Mod	Serial Number	Storage Control/CPU	MIM Page ID	MIM Page EC No.
Symptom/Error Code <span style="float: right;">If no error or symptom code, check here <input type="checkbox"/></span>				

Describe the trouble as it was reported to you, or as it appeared to you (machine problem).

Describe problem you encountered with documentation.

<p><b>Want an acknowledgement?</b></p> <p>Fill in your name and Branch Office Number:</p> <p>Name _____</p> <p>B/O No. _____</p> <p>Occupation _____</p>
--

<p><b>For plant use only</b></p> <p>Date received _____</p> <p>Sender acknowledged _____</p> <p>Research completed _____</p> <p>Incorporated by EC _____</p>
--

Thank you for your cooperation. No postage stamp necessary if mailed in the U.S.A. (Elsewhere, an IBM office or representative will be happy to forward your comments.)

Reader's Comment Form

Fold and tape

Please Do Not Staple

Fold and tape

Attention: Device Product Engineering  
Department 64P

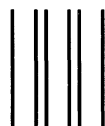

NO POSTAGE  
NECESSARY IF  
MAILED IN THE  
UNITED STATES

**BUSINESS REPLY MAIL**  
FIRST CLASS PERMIT NO. 40 ARMONK, NEW YORK

POSTAGE WILL BE PAID BY ADDRESSEE

International Business Machines Corporation  
General Products Division  
P. O. Box 27155  
Tucson, Arizona 85726

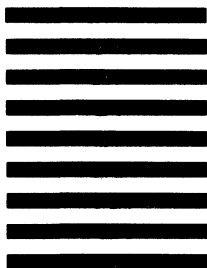

Fold and tape

Please Do Not Staple

Fold and tape



International Business Machines Corporation  
Data Processing Division  
1133 Westchester Avenue, White Plains, N.Y. 10604

IBM World Trade Americas/Far East Corporation  
Town of Mount Pleasant, Route 9, North Tarrytown, N.Y., U.S.A. 10591

IBM World Trade Europe/Middle East/Africa Corporation  
360 Hamilton Avenue, White Plains, N.Y., U.S.A. 10601

3803-2/3420

AA0010	4169693	443804	845958	846927				
Seq 8 of 8	Part Number	29 Oct 76	1 Sep 79	20 Jun 80				

© Copyright International Business Machines Corporation 1976, 1979, 1980

Reader's Comment Form

Fold and tape

Please Do Not Staple

Fold and tape

Attention: Device Product Engineering  
Department 64P

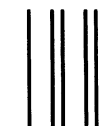

NO POSTAGE  
NECESSARY IF  
MAILED IN THE  
UNITED STATES

**BUSINESS REPLY MAIL**  
FIRST CLASS PERMIT NO. 40 ARMONK, NEW YORK

POSTAGE WILL BE PAID BY ADDRESSEE

International Business Machines Corporation  
General Products Division  
P. O. Box 27155  
Tucson, Arizona 85726

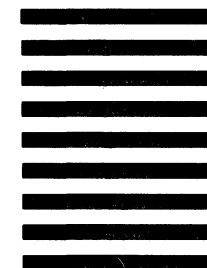

Fold and tape

Please Do Not Staple

Fold and tape



International Business Machines Corporation  
Data Processing Division  
1133 Westchester Avenue, White Plains, N.Y. 10604

IBM World Trade Americas/Far East Corporation  
Town of Mount Pleasant, Route 9, North Tarrytown, N.Y., U.S.A. 10591

IBM World Trade Europe/Middle East/Africa Corporation  
360 Hamilton Avenue, White Plains, N.Y., U.S.A. 10601

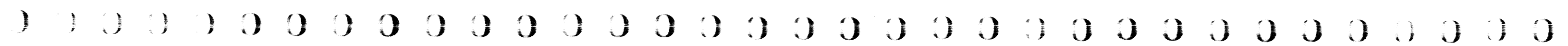

**INTRODUCTION**

The main objective of the 3803-2/3420 maintenance philosophy incorporated in the Maintenance Library Manual (MLM) is to help the CE repair hardware failures quickly. To accomplish this objective, emphasis is placed on "how to fix" rather than "how it works". For each failure, the "how to fix" approach utilizes the CE's resources, the failure isolation techniques, and the individual analysis procedures.

The five rules below must be observed in order to successfully use this manual.

1. Always start a maintenance or problem call at the top left racetrack (See symbol table on PLAN 4) entitled START on the START 1 page.
2. Always follow the procedure exactly as it is written. Do not add or delete any items.
3. Never shortcut or skip a familiar portion or begin in the middle of a MAP sequence at an obvious place.

As the MAP isolation logic narrows toward the failing FRU, questions and decisions that have been taken care of or eliminated are deliberately left out. Failure to begin at START 1 will skip some of this logic and may result in not isolating the failure or problem.

4. Always use MAP 00-030 to restore the subsystem after a successful maintenance or problem call.
5. Always use MAP 00-030 to re-enter the MAP after an unsuccessful maintenance or problem call.

**RESOURCES**

Although the maintenance philosophy is designed for the Product Trained CE, it is recognized that there are significant differences in skill levels, experience and natural ability among CEs. Additional maintenance procedures and sections of the MLM are provided to allow each CE to continue with the maintenance procedure until he has exhausted his resources, or until existing policies dictate that he request assistance.

**TECHNIQUES**

The normal card isolation technique is to replace or exchange the specified cards within a particular maintenance procedure until the failing card is located. At the CE's discretion, and/or depending on the customer's requirements, cards may be exchanged between drives to speed the isolation. In certain areas where it is not practical to rapidly exchange or replace components, information is provided to allow isolation of the failing replaceable unit.

Scoping procedures are provided if components are not available for replacement or exchange. Keep in mind that exchanging or replacing is the primary card isolation technique, and that scoping is the secondary technique.

**PROCEDURES**

Maintenance Analysis Procedures (MAPs) are provided to assist the CE in making decisions (based on sense data, OLT diagnostic results, customer data, or visual indications) to isolate the failure to the smallest possible area. MAPs are composed of analysis charts, second level diagrams, and descriptions. Analysis charts and second level diagrams refer to other material in the MLM and ALDs to provide a more complete path to failure isolation. The descriptions are provided to help the CE understand the failing operation.

**HOW TO USE MAPS, GENERAL**

The 3803-2/3420 MAPs and the 3803-2/3420 Online Tests (OLT), are the keys to the 3803-2/3420 Magnetic Tape Subsystem maintenance package. (IBM 3803-2/3420 Magnetic Tape Subsystem: Online Test User's Guide, ID number D99-3420A, is available from the IBM Corporation (See Start 2). Diagnostic Coordinator, 40 Saw Mill River Rd. Hawthorne, N.J. 07430.) MAPs should lead you step by step through the call. The IBM 3420 Field Tester (P/N 1765342 with EC 734316 for 3420 Models 4,6, and 8) and IBM Online Tests (running under OLTSEP or OS/DOS OLTEP) may be used in solving the problem.

MAPs contain a series of questions and instructions designed to analyze the failure symptoms and Sense Data. The MAPs lead to a specific Field Replaceable Unit (FRU), a set of FRUs (in cases where a single FRU cannot be identified), a failing back panel net, or an adjustment, repair, or cleaning routine.

To use these MAPs effectively, you should be trained on the 3803-2/3420 tape subsystem. Training should include:

1. The basic maintenance and operation of the subsystem.
2. Practice in using MAPs and the Online Test User's Guide.
3. Familiarity with the microcode listing, including the ability to look up a hexadecimal address from an EQUATE statement or instruction label.
4. Practice in running 3420 OLTs that support the system and ability to analyze the failing printout.
5. Practice in detecting visual failures, reading indicator lights, and using the CE panel.
6. The ability to locate subsystem components and replace all failing FRUs.

MAPs are divided into sections with the tape unit MAPs in sections 1 through 6 and tape control MAPs in sections 11 through 21.

The MAPs provide a step-by-step procedure to isolate the failure to a field replaceable unit (FRU). The procedure may require any or all of the following actions:

- Adjustments (electrical and mechanical)
- Cleaning
- FRU exchanging
- Repair or replacement of parts
- Special tests
- Scoping
- Voltage checks

**HOW TO USE MAPS, DETAILS**

See MAP 00-001 through MAP 00-007.

**HOW TO LOCATE INFORMATION**

There is a complete Index section at the back of each of the 4 volumes. These indexes contain an alphabetical list of the terms, titles, names, etc. used in the MLM. Refer to these indexes for general reference information. Do not try to use the indexes for trouble call isolation—Always use START 1 for trouble calls.

The theory of operation is in volume 4.

Checks, adjustments, removal and replacement (CARR) is in volume 2, section 08-XXX. Pages 08-000 and 08-005 contains a table of contents for section 08-XXX.

Section 20-XXX contains a cross-reference list to the pin and logic locations for the 3803 and the 3420. Use appropriate parts catalog (listed below) when ordering replacement parts.

**IBM 3803 MODEL 2/3420 MAGNETIC TAPE SUBSYSTEM.**

Related publications pertaining to this product are:

1. 3803-2/3420 Subsystem Description, GA32-0021.
2. 3420 Model 4, 6, and 8 Parts Catalog, S132-0007.
3. 3803 Models 1, 2, and 3 Parts Catalog, S132-0004.
4. 3420 Operator's Guide Card, S232-0003.
5. 3803/3420 OLT Users' Guide, D99-3420A.
6. 3420 Model 3, 5, and 7 Part Catalog, S132-0005.

3803-2/3420

XA0100 Seq 1 of 2	2735742 Part Number	See EC History	845958 1 Sep 79	847298 15 Aug 83			
----------------------	------------------------	-------------------	--------------------	---------------------	--	--	--

# ACRONYMS AND ABBREVIATIONS

ABI	adapter Bus In	clk	clock	EPO	emergency power-off	K	contactor, relay
ABO	adapter Bus Out	cm	centimeter	EPR	error pattern register	kb	kilobyte
ac	alternating current	cmd	command	EREP	environmental record edit and print	kd	kilodigit
addr	address	cmpr	compare	ERG	erase record gap	kg	kilogram
ADT	automatic data transfer	CNTL	control	ERP	error recovery procedure	kHz	kiloHertz (kilocycles/second)
ALD	automated logic diagram	cntr	counter	err	error	L	left
alt dir	alternate direction	COCC	cartridge opener control card	ESD	electro-static discharge	lbs	pounds
ALU	arithmetic and logic unit	col	column	fci	flux changes per inch	lcl	local
ARA	automatic read amplification	com	communicator	FP	file protect	LP	load point
asm	assembly	cond	condition	freq	frequency	LRC	longitudinal redundancy check
ATI	adapter Tag In	conn	connector	FRU	field replaceable unit	LRCB	longitudinal redundancy check byte
ATO	adapter Tag Out	cont	contingent connector	FSB	forward space block	LSR	local storage register
aux	auxiliary	conn		FSF	forward space file	lth	latch
BCD	binary coded decimal notation	CP	circuit protector	fwd	forward	LWR	loop write-to-read
bfr	buffer	CPU	central processing unit	GCC	grey code counter	L1-L4	vacuum column switches (left column)
bkwd	backward	CRC	cyclic redundancy check	GCR	group coded recording (6250 bpi)	mach	machine
blk	block	CRIC	channel read-in counter	gnd	ground	MAP	maintenance analysis procedure
BM or B/M	bill of material	CROC	channel read-out counter	grnd	ground	mech	mechanical
BOB	beginning-of-block	c/s	center/section	hdwr	hardware	MHz	megaHertz (megacycles/second)
BOC	branch on condition	CSW	channel status word	hex	hexadecimal	MIS	multiple interface switch
BOPE	Bus Out parity error	ctg	cartridge	HIO	halt input/output	mm	millimeter
BOR	beginning-of-record	CTI	channel Tag In	HPD	high power drive	MP	microprocessor
BOT	beginning-of-tape	ctr	counter	HPI	high power inhibit	MPL	microprogram listing
bpi	bits per inch	ctrl	control	HS	high speed	mod	model
BPI	bytes per inch	CU	control unit	HSFL	high speed field latch	ms	millisecond
br	branch	CUE	control unit end	HSR	high speed rewind	MSC	manual status control
BSB	backspace block	cw	clockwise	Hz	Hertz (cycles/second)	MST	monolithic system technology
BSF	backspace file	DAC	digital-to-analog converter	IBG	interblock gap	MTA	magnetic tape adapter
BU	branch unconditional	dc	direct current	IC	instruction counter	MTC	magnetic tape command
cap	capstan	DC	data convert	ID	identification	MTE	multi-track error
cart	cartridge	dcc	data converter check	IF	interface	mtr	motor
CAW	channel address word	dcd	decoder	inst	instruction	multi	multiple
CB	circuit breaker	DE	device end	intf	interface	mv	millivolts
CBI	channel Bus In	det	detect	IOS	input/output supervisor (system control program)	NFP	not file protect
CBO	channel Bus Out	diag	diagnostic	I/O	input/output	NOP	no operation
CC	condition code	DMS	diagnostic mode set	IPL	initial program load	NRZI	non-return to zero indicating
ccw	counterclockwise	dn	down	ips	inches/second	ns	nanosecond
CCW	channel command word	DOS	disk operating system	J1-J8	tape unit power plugs (in 3803)	OBR	outboard recorder
CE	customer engineer	DSE	data security erase	J11	EPO connector	OLT	online test
chan	channel	EC	engineering change			OLTEP	online test executive program
char	character	ECC	error correction code				
chk	check	env	envelope				
ckt	circuit	EOD	end-of-data				
		EOT	end-of-tape				

3803-2/3420

XA0100	2735742	See EC	845958	847298			
Seq 2 of 2	Part Number	History	1 Sep 79	15 Aug 83			

© Copyright International Business Machines Corporation 1976, 1979, 1983

# ACRONYMS AND ABBREVIATIONS (Cont'd)

PLAN 3

OLTSEP	online test stand-alone executive program	run	rewind/unload	uk	unit check
op	operation	R/W	read/write	unld	unload
OP IN	operational in (tag line)	R1-R4	vacuum column switches (right column)	unreg	unregulated
OS	operating system	SA	service aid	μpgm or μprog	microprogram
osc	oscillator	SAGC	self-adjusting gain control	μsec	microsecond
ov	over voltage	SCC	solenoid control card	uv	under voltage
OV/UV	over voltage/under voltage	SCR	silicon controlled rectifier	UV/OV	under voltage/over voltage
pb	pushbutton	SCRA	solenoid contact relay assembly	vac	vacuum
pc	printed circuit	SDR	statistical data recorder	vel	velocity
PC	parity check	sec	second	VFC	variable frequency control
PCB	printed circuit board	sel	select	VM	voltage monitor
PDC	proportional drive counter	seq	sequence	VRC	vertical redundancy check
PE	phase encoded (1600 bpi)	Set CE/Cmpr	set CE register/set compare register	VRCR	vertical redundancy check register
PF	pathfinder	SIO	start I/O	w/ or w	with
PG	parity generator	sol	solenoid	WC	write clock
pgm	program	ss	singleshot	w/o	without
PHD	polarity hold drive	st	status	wr or wrt	write
PID	Programming Information Department	stp	stop	WTM	write tape mark
PN or P/N	part number	SVP	service processor	xfr	transfer
pneu	pneumatic	sw	switch	xlate	translate
POR	power on reset	SYSGEN	system generation	xpt	crosspoint
p-p	peak-to-peak	tach	tachometer	2CS	two channel switch
prop	proportional	TB	terminal board		
PTE	P-track envelope	TC	tape control		
PTF	program temporary fix	TCS	two-channel switch		
ptrs	pointers	TCU	tape control unit		
pty	parity	tgr	trigger		
pwr	power	TI	tape indicate		
R	right	TIE	track-in-error		
rc	resistor/capacitor	TIO	test I/O		
rd	read	tk or trk	track		
RDD	read disconnect delay	TM	tape mark		
rdy	ready	TP	test point		
REA	Request for Engineering Action	TPC	tach period counter		
reg	register	TU	tape unit		
REJ-TU	reject tape unit	TUBI	tape unit Bus In		
rem	remote	TUBO	tape unit Bus Out		
req	request	TU CHK	tape unit check		
rew	rewind	Tx	transistor		
RIC	read in counter				
ROC	read out counter				
ROS	read only storage				
rst	reset				

3803-2/3420

XA0200	2735743	See EC History	845958				
Seq 1 of 2	Part Number		1 Sep 79				

© Copyright International Business Machines Corporation 1976, 1979

PLAN 3

Circuit Blocks

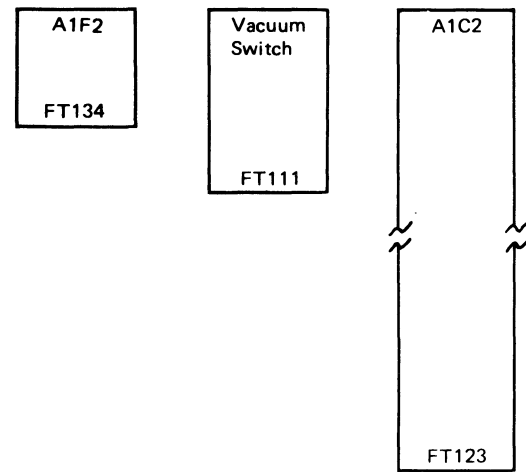

Capstans, Reel Motors, Pneumatic Pumps and Motors

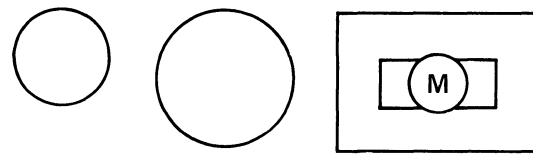

Wave forms, Pulses



Notes:

[n] n = some number

Timing Diagrams: (example of)

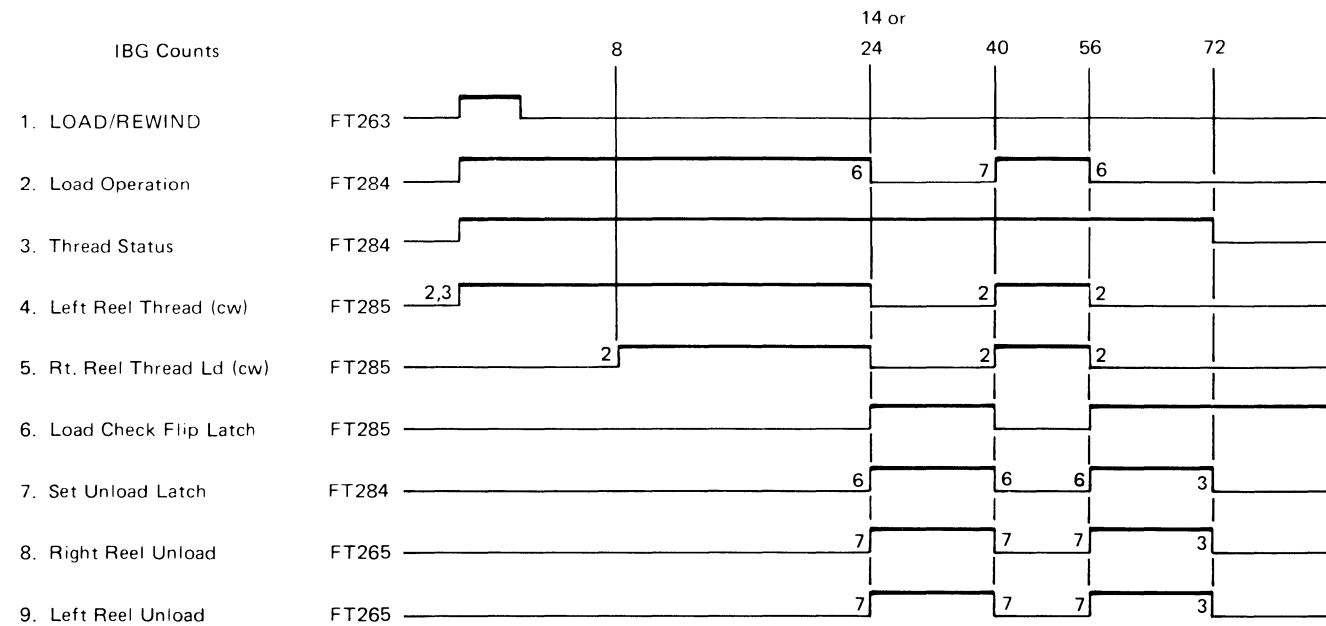

PANEL LOCATION, PIN SYMBOLS

- A1D2P03
- Y1N2G06 Refers to the control unit.
- A2K3B04
- T-A1D2B07 Refers to the tape unit.  
T-A1XXXXX is used to avoid confusion with the control unit A1 panel.
- A1D2B07 May be used when the tape unit location is clearly defined.

Callouts



Flowchart Symbols

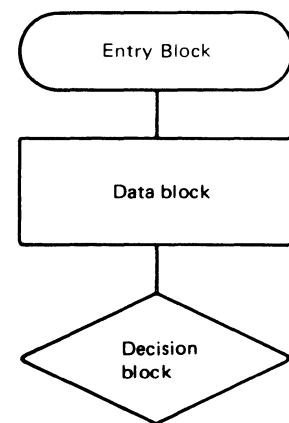

Maintenance Library Divider Tab

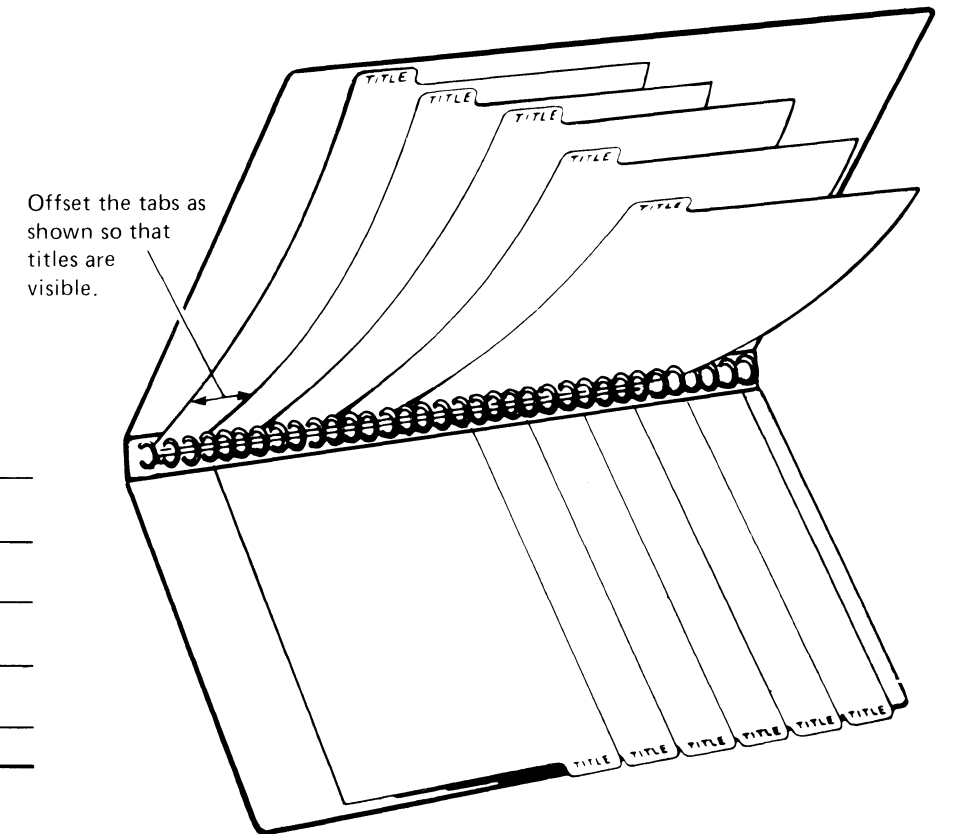

Insert these tabs in the binders containing the IBM 3803-2/3420 Tape Subsystem Maintenance Library.

3803-2/3420

XA0200	2735743	See EC	845958				
Seq 2 of 2	Part Number	History	1 Sep 79				

© Copyright International Business Machines Corporation 1976, 1979

## GLOSSARY OF TERMS

PLAN 5

**Babysitter.** A monitoring device.

**Blown.** This term is used to define a fuse or circuit card that is electrically defective. It is usually applied to an open fuse.

**Bobble.** The oscillation of the tape back and forth over a vacuum switch while the tape unit is idle.

**Bottoms.** When the tape goes beyond the lowest port switch, it piles up at the bottom of the column.

**Degauss.** The de-magnetization of tape, heads, and magnetic materials.

**Fetch.** To go or come after, to bring or take back, to retrieve, to bring about, or to bring in.

**Gauss.** A term used to define magnetic flux density.

**Hot.** Indicates that a line, condition, bit, or latch, is in the active state erroneously.

**SAGC and ARA.** Automatic read amplification (ARA) is derived from logic functions of the self-adjusting gain control (SAGC) in the tape control and tape unit.

**Singleshot.** An electronic latch designed to stay in the active state a limited time after the initial input, then automatically go inactive.

**Splash.** An undefined burst of magnetic flux recorded on tape.

**MP1 and MP2.** Throughout this publication references are made to Microprocessor 1 (MP1) and Microprocessor 2 (MP2). See pages 50-000 through 50-003 for schematics of the data flow logic and microprocessors.

**μpgm, μprogram. Microprogram.** A program of microinstructions; using basic subcommands.

**Wobble.** The oscillations of the capstan wheel or tape reel. It indicates alignment problems, a worn shaft or bearing, or an out-of-balance condition.

3803-2/3420

XA0300 Seq 1 of 2	4169704 Part Number	See EC History	845958 1 Sep 79						
----------------------	------------------------	-------------------	--------------------	--	--	--	--	--	--

© Copyright International Business Machines Corporation 1976, 1979

PLAN 5

# ORGANIZATION OF PUBLICATION

# PLAN 6

## VOLUME 1

### PLAN

This section covers the objectives, procedures and organization of the IBM 3803-2/3420 MLM.

### START

All maintenance and problem calls begin after this tab.

### SENSE

Control unit and tape unit sense data is presented after this tab.

### MAP 00-xxx

Quick Fix reference list and other miscellaneous data, plus the start and end of the MAPs.

### MAP 1A-000

### MAP 5A-000

These tabs 1A (2A)\*, 3A, 4A, and 5A (6A)\* separate the various MAPs for the models (3, 5, 7) tape drives attached to a 3803-2 control unit. (See **Note**).

### MAP 1B-000

### MAP 5B-000

These tabs 1B (2B)\*, 3B, 4B, and 5B (6B)\* separate the various MAPs for the models (4, 6, 8) tape drives attached to a 3803-2 control unit. (See **Note**).

\*Indicates section without a tab.

3803-2/3420

XA0300	4169704	See EC	845958					
Seq 2 of 2	Part Number	History	1 Sep 79					

© Copyright International Business Machines Corporation 1976, 1979

## VOLUME 2

### INTF 07-xxx

Device Selection, Interface lines (Bus In and Bus Out), plus tape motion and dropping Ready problems.

### CARR 08-xxx

After this tab Checks, Adjustments, Removal and Replacement instructions are presented.

### MAP 11-xxx

### MAP 15-xxx

General MAPs from 11, (12)\*, 13, (14)\*, 15 are presented after each of these tabs. These MAPs are for both 3420 (models 3, 5, 7) and 3420 (models 4, 6, 8) tape drives, and the 3803-2 control unit.

#### Note:

Models 3, 5, 7 MAP page numbers in Volume 1 end with the letter A.

Models 4, 6, 8 MAP page numbers in Volume 1 end with the letter B.

Examples:

2A-120 = (Models 3, 5, 7)

2B-120 = (Models 4, 6, 8)

00-005 = All Models

## VOLUME 3

### MAP 16-xxx

### MAP 20-xxx

General MAPs from 16 through 21 (21)\* are presented after each of these tabs. These MAPs are for both (models 3, 5, 7) and (Models 4, 6, 8) tape drives, and the control unit.

## VOLUME 4

### OPER 40-xxx

### OPER 58-xxx

After these tabs the Theory of Operations data is presented. There are eight sections. They are 40, 50, 52, 53, (54)\*, 55, (57)\*, and 58.

### REF 75-xxx

After these tabs the Reference data is presented in three sections. The sections are 75, (80)\* and (85)\*.

### INSTAL 90-xxx

This section tab identifies the installation instructions.

### INDEX

After this tab is the index to all four volumes.

# PLAN 6



# MLM TAB PLACEMENT BY VOLUME

# PLAN 7

Tabs for Volume 1

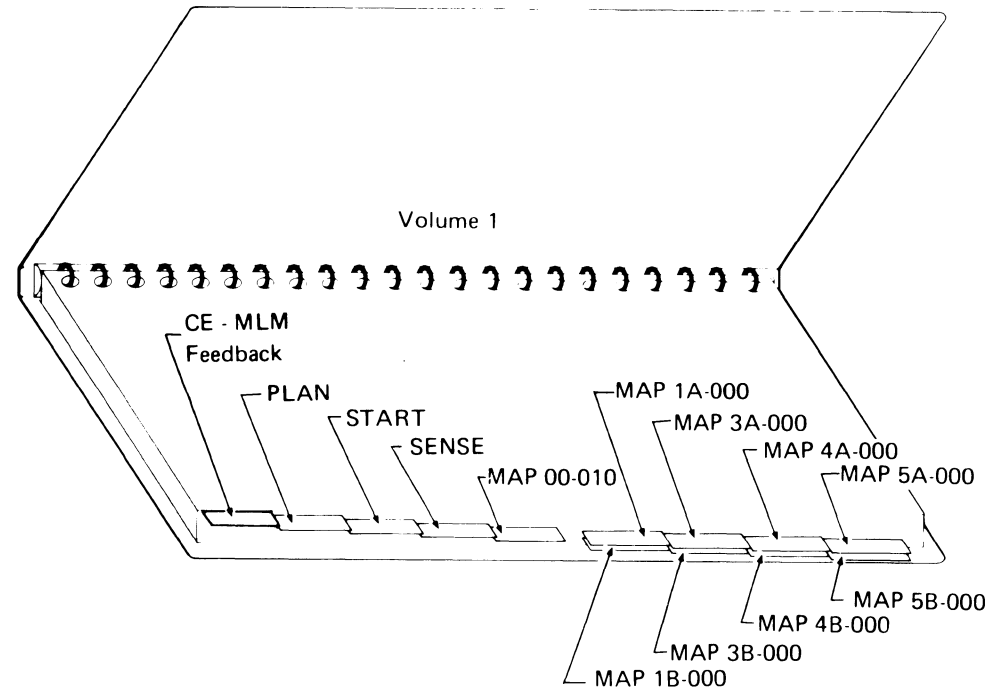

Tabs for Volume 2

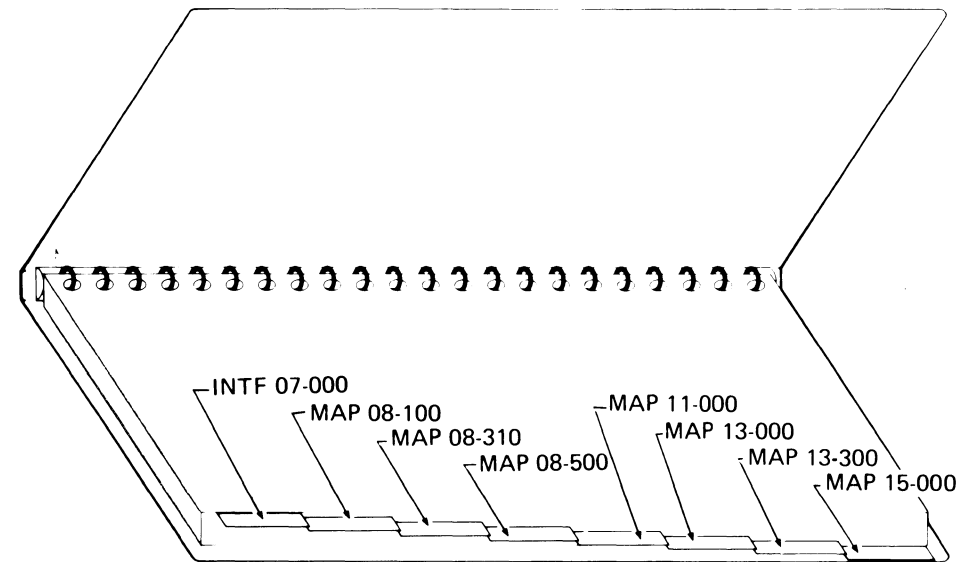

Tabs for Volume 3

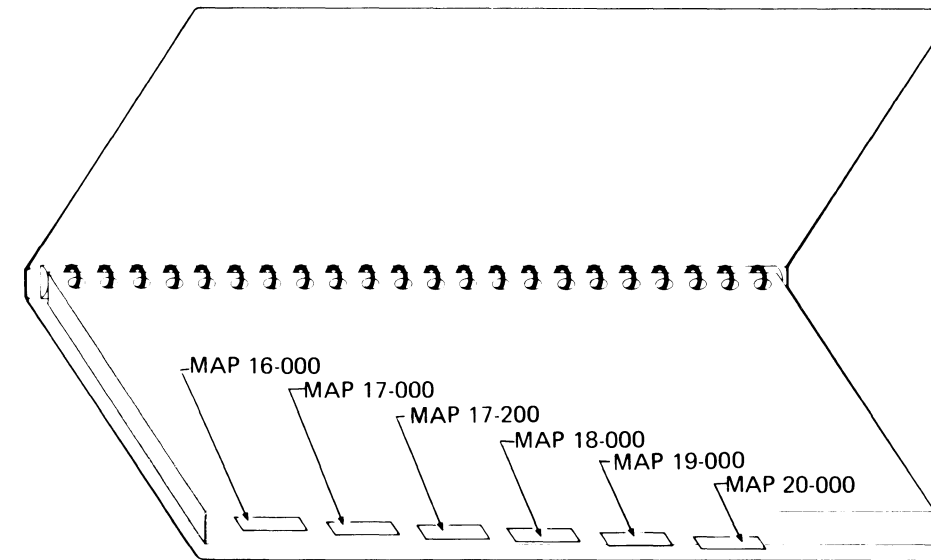

Tabs for Volume 4

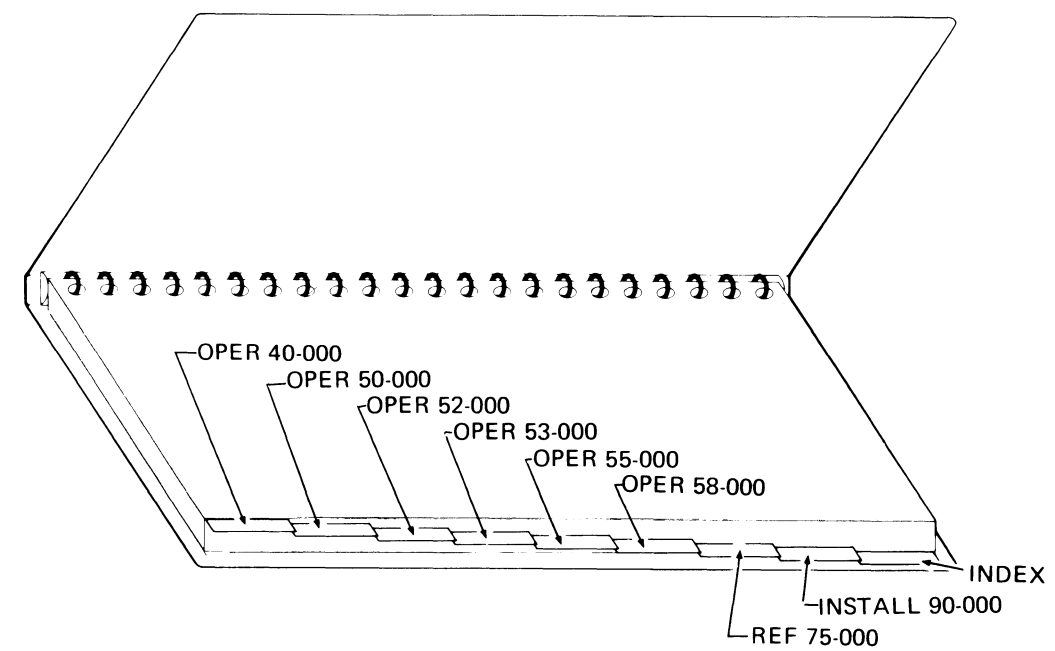

3803-2/3420

XA0400	4169705	See EC	845958				
Seq 1 of 2	Part Number	History	1 Sep 79				

© Copyright International Business Machines Corporation 1976, 1979

# PLAN 7

NOTES:

PLAN 8

3803-2/3420

XA0400	4169705	See EC	845958					
Seq 2 of 2	Part Number	History	1 Sep 79					

© Copyright International Business Machines Corporation 1976, 1979

PLAN 8



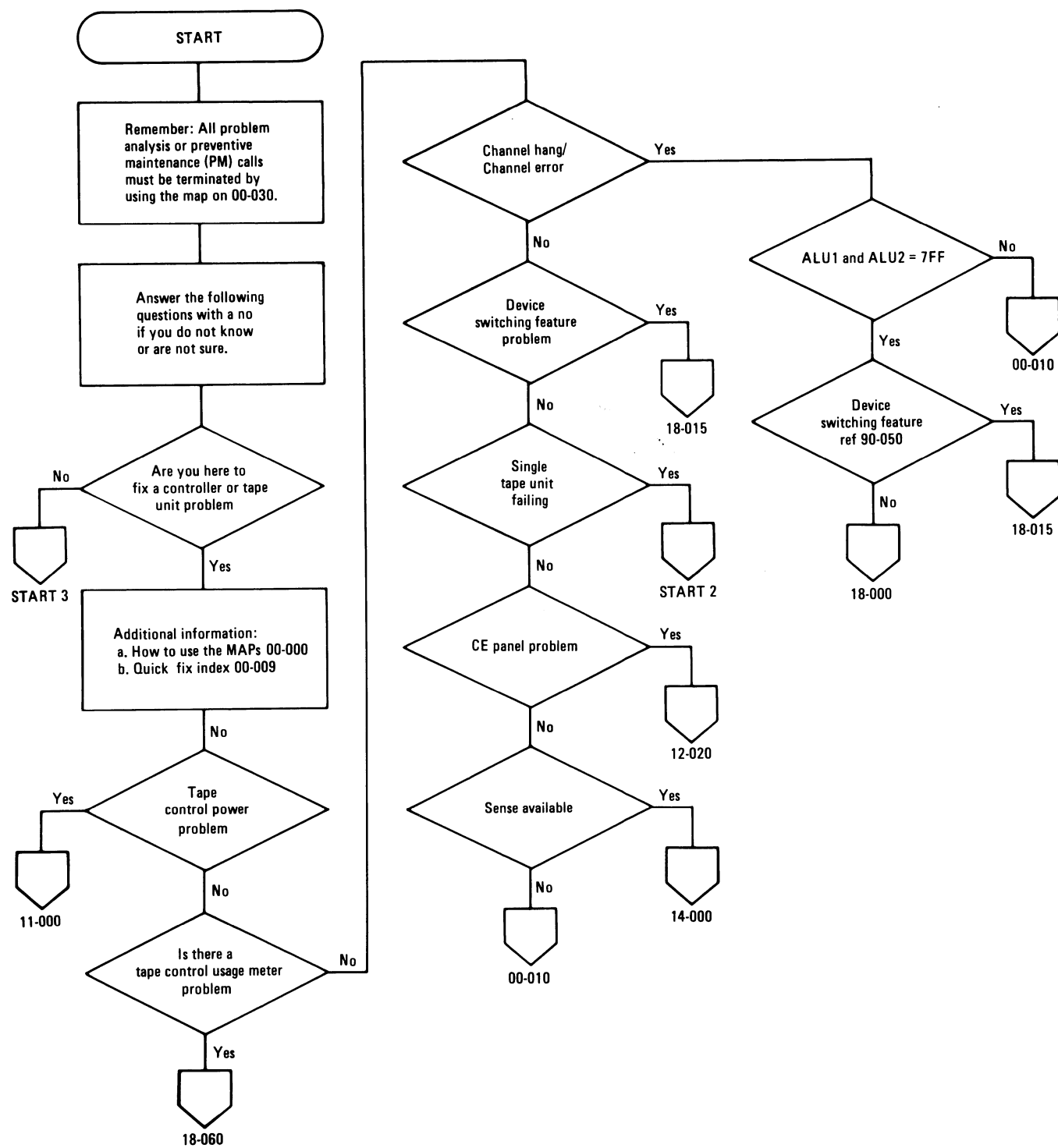

3803-2/3420

XB0050 Seq 1 of 2	4169414 Part Number	See EC History	845958 1 Sep 79	846927 20 Jun 80	847298 15 Aug 83			
----------------------	------------------------	-------------------	--------------------	---------------------	---------------------	--	--	--

© Copyright International Business Machines Corporation 1976, 1979, 1980, 1983

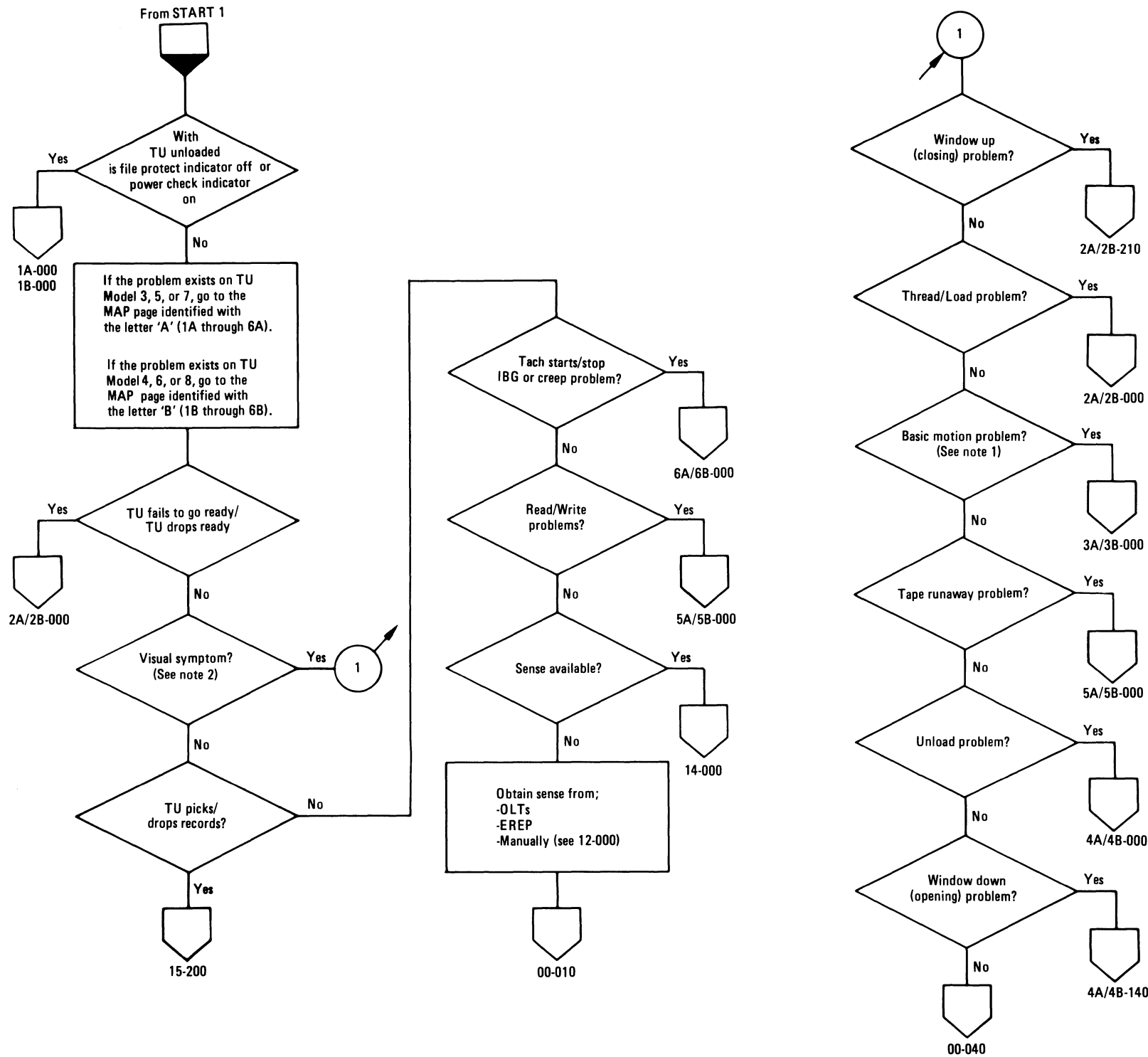

**Notes:**

1. Observe forward, backward, high speed, low speed rewind and start/stop operations.
2. Load failures, tape motion problems, rewind problems, unload failures, tape runaway, or window problems.

3803-2/3420

XB0050 Seq 2 of 2	4169414 Part Number	See EC History	845958 1 Sep 79	846927 20 Jun 80	847298 15 Aug 83			
----------------------	------------------------	-------------------	--------------------	---------------------	---------------------	--	--	--

© Copyright International Business Machines Corporation 1976, 1979, 1980, 1983

START 1

A

**System Checkout**  
 OLT Users Guide  
 System Diagnostic 90-200

**Sense Information**  
 Chart 00-005  
 Analysis (MAP) 14-000

**How to Use:**  
 CE Panel 12-010  
 Field Tester 80-020  
 MAPs 00-000

**Checks, Adjustments, Removals, Replacements**  
 Index 08-000

**Theory**  
 Subsystem and Control 40-001  
 Tape Unit Initial Selection 07-000  
 Tape Control and Tape Unit Selection and Priority 54-005  
 Also see the Index for Specific Subjects

**Preventive Maintenance**  
 Schedule 85-000

**Installation**  
 Cabling  
 Card Plugging  
 Control Unit and Device Address Plugging 90-000

**Other (Related) Subsystem Documents**

Online tests are documented in IBM Maintenance Program: *IBM 3803/3420 Magnetic Tape Subsystem: Online Tests User's Guide* (ID number D99-3420A, available by ordering using the DOC (Diagnostic Order Calculator) program at the Branch Office.

Subsystem Description 3803-2 GA32-0021

See PLAN1, *IBM 3803 Model 2/3420 Magnetic Tape Subsystem* for additional publications for this system.

3803-2/3420

<b>XB0060</b>	<b>8492594</b>	<b>See EC</b>	<b>845958</b>						
Seq 1 of 2	Part Number	History	1 Sep 79						

NOTES:

START 4

3803-2/3420

<b>XB0060</b> Seq 2 of 2	<b>8492594</b> Part Number	<b>See EC</b> <b>History</b>	<b>845958</b> 1 Sep 79						
-----------------------------	-------------------------------	---------------------------------	---------------------------	--	--	--	--	--	--

© Copyright International Business Machines Corporation 1976, 1979

START 4



## HOW TO USE MAPs, DETAILS

00-000

For overall understanding of the IBM 3803-2/3420 MLM, see the PLAN section. See 00-001 through 00-003 for MAP usage details.

**Note:** All problem and maintenance calls begin at START 1. Do Not begin calls by starting in the MAP sections, see PLAN 1. All calls end on MAP 00-030.

3803-2/3420

<b>XB0100</b> Seq 1 of 2	<b>2735744</b> Part Number	<b>See EC</b> <b>History</b>	<b>845958</b> 1 Sep 79						
-----------------------------	-------------------------------	---------------------------------	---------------------------	--	--	--	--	--	--

© Copyright International Business Machines Corporation 1976, 1979

00-000

MAP FORMATS

MAPs have two basic formats. The second style format is shown on 00-002. Some tape unit MAPs are presented in the format shown to the right. The diagram shows the parts of a MAP, how they are used, and what the notations mean. Number keys indicate:

- 1 Page number and title of the diagram, followed by the Start symbol. Always begin reading a diagram at START. Tape unit MAP numbers include an A or B; A designates tape unit Models 3, 5, and 7, and B designates Models 4, 6, and 8.
- 2 A block of text containing theory information and special instructions pertinent to the diagram. Always read this information before beginning testing.
- 3 Arrows which lead from the text to where testing starts - usually for voltage levels. Make tests one at a time from top to bottom. Tests are useless if testing is not done from top to bottom. As the large arrows at the top show, go to the right for the correct test results and to the left when test results are incorrect. In other words:

If all tests show correct voltage levels, go right and make tests (going from top to bottom again) indicated at the next block.

If any test shows an incorrect voltage level, stop testing at that block, go left, and make any tests (going from top to bottom again) indicated at the next block.

Continue going left for incorrect results and right for correct results until you isolate the block that has correct signals coming into it from the left, but has incorrect signals going out to the right. This block represents the field replaceable unit (FRU) that should be replaced.

- 4 The machine location of the logic card represented by this block on the diagram. All designations of the form xnxn are logic card locations. An x equals an alpha character and n equals a number. If present, the logic card locations appear as the first line at the top of a block on the diagram.
- 5 Designations of the pins being tested usually are preceded by + for standard plus or up level, and - for standard minus or down level. If there is no + or -, special voltages are indicated in nearby comments, or the pin designation is merely a label for a path to be followed. All designations of the form xnn are pin designations, and always appear above the logic path they mark.
- 6 Indications of expected voltages. The square wave indicates voltage should alternate between the standard plus (up) and the standard minus (down) levels. The explicit voltage indicates that the specified voltage should be present. (Detailed information regarding voltages is contained in a Note. See [n]).

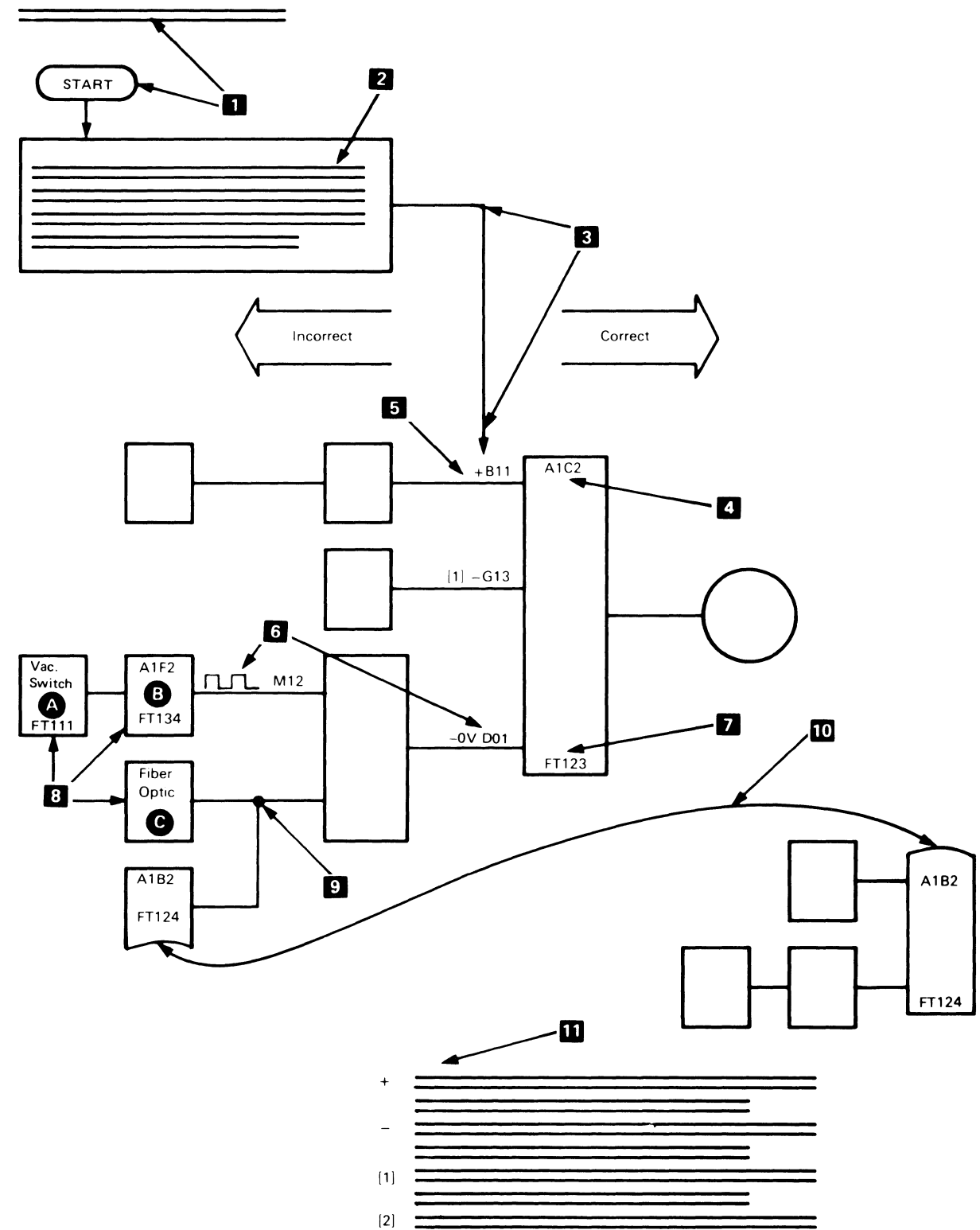

3803-2/3420							
XB0100	2735744	See EC	845958				
Seq 2 of 2	Part Number	History	1 Sep 79				



**7** Designation of the automated logic diagram (ALD) page on which this logic block is found. ALD page references, represented by the form xnnn or xnnx always appear as the bottom line of a block.

References to different ALD pages for 50-Hz or 60-Hz operations use the form xnn0/5. The number ending in 0 means a 60-Hz operation and the number ending in 5 is a 50-Hz operation. (For example, YB030/5 means ALD page YB030 for 60 Hz and YB035 for 50 Hz.) Where ALD page numbers have an x in the low order position, the x represents 1 through 9, depending on the input source.

**8** Examples of blocks representing three different types of FRUs. **A** gives a functional name of an FRU and its ALD page, **B** gives a logic card location and its ALD page, and **C** gives a functional name only.

**9** A junction in the logic path. Junctions are marked by black dots at the intersection of the lines. Crossed lines without dots do not connect. When a logic path divides at a junction into two or more parallel subpaths, replace the FRU(s) one at a time from top to bottom.

**10** A line (always curved) that indicates continuation of a block at another place on the page. Follow the line and continue testing normally. Partial blocks are shown at each end of the continuation line for ease of reference, but the block appears only once in logic. Curved continuation lines also indicate continuation from one diagram to another on the same page.

**11** Notes to indicate such things as voltages expected, references to other topics in the MAPs, or explanations of conditions under which pulses can occur. Notes are called out by numbers in brackets like this [ 1 ].

Optional

MAPS also have the following format:

FROM:		
ERROR DESCRIPTION:		
FRU List or Most Probable Cause: XXXX		
Notes: ----		
Always start with Seq 1 and follow the procedure in sequence unless directed otherwise. Remember to END all problem or maintenance calls by going to MAP 00-030.		
Seq	Condition/Instruction	Action
1	----	----

} Optional

The MAP title describes the problem the MAP is developed to solve.

**FROM** specifies the MAP that sent you here.

**ERROR DESCRIPTION** identifies the sense bit(s) and defines error check conditions.

**FRU LIST** lists all known FRUs which cause the error, with the most likely FRU(s) at the top of the list.

**Most Probable Cause** Indicates those cards which may cause the specific failure.

Replace FRU(s) in the sequence specified.

**Notes:** Special information for the MAP.

The **Condition/Instruction** column asks a question or gives directions.

For every "Yes" answer to a question, proceed to the Action column. For every "No" answer, go to the next sequence (sequence number). When an instruction does not ask a question, proceed to the next sequence.

The **Action** column provides instructions to fix the problem.

If a repair action does not lead to another sequence, do not try to continue following the MAP. This is the failing area of the machine.

If the problem is not resolved, reconstruct the path and review the MAP.

After exhausting a MAP and the problem cannot be identified, go to 00-030.

**TYPICAL FLOW THROUGH MAPS**

If the answer to the question is yes, go to the Action column; if the answer is no or you are not sure of the answer, go to the next sequence.

Start at 00-101		
Seq	Condition/Instruction	Action
1	Does a single tape unit fail?	Analyze symptoms and go to 00-040.
2	Exclusive Sense or Symptom?	Go to Map xx-yyy.
3	System available for OLTEP?	Go to Seq 7.
4	Gather offline Sense.	
5	Manual Sense Analysis 14-000	
6	Go to MAP xx-zzz	
7	Read only fails?	Go to Seq 25.
8	Write/Read fails?	Go to Seq 43.
9	If not:	Go to MAP xx-yyy
10	Problem unresolved?	Go to 17-800.

MAP 00-009 has a quick index which can aid you in using the MAPs. If it does not locate the problem, restart on 00-030.

3803-2/3420

<b>XB0200</b> Seq 1 of 2	<b>2735745</b> Part Number	<b>See EC History</b>	<b>845958</b> 1 Sep 79	<b>847298</b> 15 Aug 83				
-----------------------------	-------------------------------	-----------------------	---------------------------	----------------------------	--	--	--	--

**LINE LEVELS -  
ACTIVE/INACTIVE/PULSING/SWITCHING**

Line names and active levels are shown for all pins scoped.

Examples:

- IBG means minus is active
- +IBG means plus is active

Source pins of nets (not necessarily the pin being scoped) are listed in 20-XXX. The MAPs always assume correct levels and nominal rise and fall times. If a bad line is scoped, do not continue, but go to 20-XXX and locate the net, then trace it back to the failing point.

**STANDARD VOLTAGES**

Level	(Y1Q2) SLD	Device Interface	Channel	MST Back Panel
Plus	+6	+4.4	+4 to +1.70v (active)	-.61 to -.96
Minus	0	+0.5 (active)	0 to +.70v	-1.57 to -2.35

**MICROPROGRAM ADDRESSES**

To keep MAPS applicable to any EC level of microcode, only a few special hex addresses are used in the MAPs. In most cases Compare addresses and references to microinstructions are designated by the instruction's label or equate statement.

LOC	Object	STMT	Source	Statement
000000		973	STEP0001	EQU *
000000	2FF5	975	CHKRSTS	BOC PWRRST, MODEREGS

The Branch instruction at address 000 may be denoted by CHKRSTS or STEP0001 in MAPs.

Convert the label called out in the MAP by turning to the cross-reference pages located behind each microcode listing. Find the label listed under the "Symbol" column and then refer to the "Value" column for the associated hex address.

**TIMING CHARTS**

When provided, timing charts follow the MAP in a section and contain card pins and approximate timings for reference.

A few MAPs do not follow any of these formats.

<b>XB0200</b> Seq 2 of 2	<b>2735745</b> Part Number	<b>See EC History</b>	<b>845958</b> 1 Sep 79	<b>847298</b> 15 Aug 83				
-----------------------------	-------------------------------	-----------------------	---------------------------	----------------------------	--	--	--	--

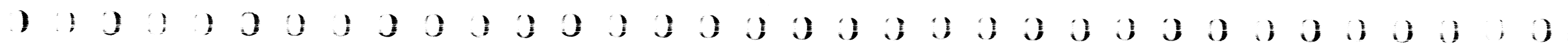

STATUS BYTE AND SENSE BYTE 0-12

STATUS BYTE	Bit 0	Bit 1	Bit 2	Bit 3	Bit 4	Bit 5	Bit 6	Bit 7
	Attention	Status Modifier	Control Unit End	Busy	Channel End	Device End	Unit Check	Unit Exception
SENSE BYTE	Bit 0 (8)	Bit 1 (4)	Bit 2 (2)	Bit 3 (1)	Bit 4 (8)	Bit 5 (4)	Bit 6 (2)	Bit 7 (1)
Byte 0	Command Reject 15-020 (U)	Intervention Required 15-010 (U) ▶	Bus Out Check 15-030 (U)	Equipment Check 00-006 (U)	Data Check 00-006 (U)	Overrun 15-040 (U)	Word Count Zero 15-050 (U)	Data Converter Check 15-070 (U)
Byte 1	Noise 17-370 (U) (D)	TU Status A 00-006 ▶	TU Status B 00-006 ▶	Seven Track 00-006	Load Point 00-006 ▶	Write Status 00-006 ▶	File Protected 00-006 ▶	Not Capable 15-060 (U)
Byte 2	Track In Error 17-602							
Byte 3	Read/Write VRC 17-168 (D)	MTE/LRC 17-110, 17-310 (D)	Skew Error 17-160 (D)	End Data Check/CRC 17-530 (D)	VRC/Envelope Check 17-220, 17-310 (D)	1600 BPI Set In TU 00-007	Backward 00-007	P Compare/C Compare 17-010 (D)
Byte 4	MP Hardware Error 00-007 (E) ▶	Reject Tape Unit 00-007 (E)	Tape Indicate 00-007	Write Trigger VRC 17-020 (D)	Spare	Loop Write To Read 00-007	Tape Unit Check 00-007 ▶	Reserved For RPQ
Byte 5	New Subsystem 00-007	New Subsystem 00-007	Write Tape Mark Check 17-180 (D)	ID Burst Check 17-050 (U)	Start Read Check 17-070 (D)	Partial Record 17-410 (D)	Postamble Error 17-190 (D)	Reserved For RPQ
Byte 6	Seven Track Tape Unit 00-007	Write Current Failure 15-090 (E) ▶	Dual Density 00-007	3420 Not Set To 1600 BPI 00-007	Model 4/6/8 00-007	Tape Unit Model Identification 00-007		
Byte 7	Lamp Failure 15-090 ▶	Tape Bottom Left 15-090 ▶	Tape Bottom Right 15-090 ▶	Reset Key 15-090 ▶	Data Security Erase 15-090	Erase Head Failed 15-090 ▶	Air Bearing Pressure 15-090 ▶	Load Failure 15-090 ▶
Byte 8	IBG Detected 17-080 (D)	Spare	Spare	Early Begin Read Back Check 17-100 (E) (D)	SAGC Check 16-220 (E)	Slow Begin Read Back Check 00-007 (D)	Slow End Read Back Check 17-150 (D)	Velocity Retry/Restart 00-007
Byte 9	1 or 2 Track Correction 17-600	Velocity Change During Write 16-180, (D)	Channel Buffer Check START 1	CRC III 17-540, 17-590	6250 Tape Control 00-007	Spare	Spare	Tape Control Unit Reserved 00-007
Byte 10	Command Status Reject 16-160 (E)	Spare	Control Status Reject 16-210 (E)	No Block Detected on Write/WTM 16-190 (E)	Dynamic Reversal 16-200 (E)	Tach Start Failure 16-170 (E)	Spare	Velocity Check 16-180 (E)
Byte 11	B Bus Parity Error ALU1 16-030 (B) ▶	Spare	Low ROS Parity/Low IC Parity on Branch Instruction 16-010 (B) ▶	Hi IC/Br Cond/Hi ROS Register Parity 16-020 (B) ▶	Microprogram Detected Hardware Error 16-060 (B) ▶	D Bus Parity ALU1 16-040 (B) ▶	Spare	Br Cond Error ALU1 16-050 (B) ▶
Byte 12	B Bus Parity Error ALU2 16-100 (B) ▶	Spare	Low ROS Parity/Low IC Parity on Branch Instruction 16-080 (B) ▶	Hi IC/Br Cond Error/Hi ROS Register Parity 16-090 (B) ▶	Microprogram Detected Hardware Error 16-130 (B) ▶	D Bus Parity ALU2 16-110 (B) ▶	Spare	Br Cond Error ALU2 16-120 (B) ▶

3803-2/3420

<b>XB0300</b> Seq 1 of 2	<b>2735746</b> Part Number	<b>See EC History</b>	<b>845958</b> 1 Sep 79	<b>847298</b> 15 Aug 83			
-----------------------------	-------------------------------	-----------------------	---------------------------	----------------------------	--	--	--

SENSE BYTE 13-23

SENSE BYTE	Bit 0 (8)	Bit 1 (4)	Bit 2 (2)	Bit 3 (1)	Bit 4 (8)	Bit 5 (4)	Bit 6 (2)	Bit 7 (1)
Byte 13	Tape Control Features		Tape Control Unique Identification (High Order Serial Number Digits)					
Byte 14	Tape Control Unique Identification (Low Order Serial Number Digits)							
Byte 15	Tape Unit Unique Identification (High Order Serial Number Digits)							
Byte 16	Tape Unit Unique Identification (Low Order Serial Number Digits)							
Byte 17	Tape Control Features				Tape Control EC Level			
Byte 18	Power Check/Air Flow ▶	Spare	Spare	Spare	Tape Unit EC Level			
Byte 19	TU 7 Primed for DE ▶	TU 6 Primed for DE ▶	TU 5 Primed for DE ▶	TU 4 Primed for DE ▶	TU 3 Primed for DE ▶	TU 2 Primed for DE ▶	TU 1 Primed for DE ▶	TU 0 Primed for DE ▶
Byte 20	TU F Primed for DE ▶	TU E Primed for DE ▶	TU D Primed for DE ▶	TU C Primed for DE ▶	TU B Primed for DE ▶	TU A Primed for DE ▶	TU 9 Primed for DE ▶	TU 8 Primed for DE ▶
Byte 21	Load Rewind Button Pressed	Left Reel Turning	Right Reel Turning	Tape Present	Reels Loaded	Load Rewind	Load Complete	Load Check
Byte 22	Field Replaceable Unit Identification ▶							
Byte 23	Field Replaceable Unit Identification (See Control/Command Status Reject) ▶							

- Notes:
- (B) Sets Bus Out Check when there are no other bits on in Sense Byte 0.
  - (D) Sets Data Check
  - (E) Sets Equipment Check
  - (U) Sets Unit Check
  - ▶ May change status between consecutive Sense commands

TAPE UNIT SENSE BYTES

Byte	Bit 0	Bit 1	Bit 2	Bit 3	Bit 4	Bit 5	Bit 6	Bit 7
Byte 0	Backward	Not File Protect	EOT	BOT	Write Status	Start	Unit Check	Not Busy
Byte 1	7-Track	Write Current Fail	Dual Density	Alternate Density	Mod 4, 6, or 8	011= 75 ips 100=125 ips 101=200 ips		
Byte 2	Lamp Failure	Left Col Failure	Right Col Failure	Door Interlock or Reset Key	Data Security Erase	Erase Head Failure	Air Bearing Failure	Load Failure
Byte 3	High and Low Tape Unit Serial Number							
Byte 4								
Byte 5	Air Flow Voltage Check	High Order Serial Number	High Order Serial Number	High Order Serial Number	EC Level of Tape Unit			
Byte 6	Allows Read Bus and Tach Pulses (crease tape)							
Byte 7	Load Rewind Button Pressed	Left Reel Turning	Right Reel Turning	Tape Present	Reels Loaded	Load Rewind	Load Complete	Load Check

SENSE BYTE BITS NOT DEFINED IN MAPs

Sense Byte 0

Bit 3 - Equipment Check

Equipment Check is set on a tape control connected operation when:

1. Bit 0 or 1 of sense byte 4 is set.
2. Bit 3 or 4 of sense byte 8 is set.
3. Bit 0, 2, 3, 4, 5, or 7 of sense byte 10 is set.
4. Bit 0, 1, 2, 3, 4, 5, or 7 of sense byte 12 is set if error occurred between presentation of initial and ending status and the command involved tape motion.

Bit 4 - Data Check

Data Check is set when:

1. End of Block is sensed before any data bytes are detected during a 6250 bpi or PE (1600 bpi) read or read backward operation. Bit 0 of sense byte 1 is set (noise).
2. Bit 0, 1, 2, 3, 4, or 7 of sense byte 3 is set.
3. Bit 3 of sense byte 4 is set.
4. Bit 2, 4, 5, or 6 of sense byte 5 is set.
5. Bit 0, 3, 5, or 6 of sense byte 8 is set.
6. Bit 1 of sense byte 9 is set.

SENSE BYTE 1

Bits 1 through 6

- 1 TU STATUS A TU STATUS A is set when an addressed tape unit is selected, ready, and not busy.
- 2 TU STATUS B TU STATUS B is set when an addressed tape unit is not ready. Assuming no outstanding device end status, bits 1 and 2 determine response to initial selection as follows:

TU STATUS A#	TU STATUS B#	TU Status	Response to Initial Selection
Off	Off	Non-existent	Unit Check*
Off	On	Not Ready Arm for Device End	Unit Check*
On	Off	Ready and not rewinding	Clean Status

\*Unit Check is not signaled for a sense operation unless the sense instruction had bad parity at command out time or a hardware error occurred (sense byte 11 or 12) during initial selection.

In the 2400 series, TU STATUS A and TU STATUS B are lines from the tape unit. They do not exist in the 3803-2/3420 Subsystem; they are generated by the tape control from tape unit responses.

- 3 **Seven Track** Seven Track is set when the selected tape unit has the 7-Track feature.
- 4 **Load Point** Load Point is set when the selected tape unit is at the beginning-of-tape (BOT).
- 5 **Write Status** Write Status is set when the selected tape unit is in write status.
- 6 **File Protect** File Protect is set when the selected tape unit is in file protect status.

SENSE BYTE 2 (TIE)

This sense byte contains track in error (TIE) indicator bits set at the end of a read, read backward, write, or loop-write-to-read (LWR) command.

**Caution: For 6250 and PE operations, if a read/write (R/W) vertical redundancy check (VRC) is indicated (byte 3, bit 0), the TIE byte is invalid or unreliable.**

For 6250 bpi operations, sense byte 2 indicates the track(s) that are deadtracked due to one or more of the following:

1. Excessive leading or lagging skew in a given track(s) before data readout during read or write operations.
2. Any valid pointers present when end of data is detected during read or write operations.
3. Time sensor down (no data being read) on write operations.
4. Excessive leading or lagging skew in a given track(s) after data readout if a valid pointer is present on read operations only.

For PE operations, sense byte 2 indicates the track(s) that are dead tracked due to one or more of the following:

1. Time sensor down (no data being read) on read or write operations.
2. Excessive leading or lagging skew in a given track(s) before data readout during read or write operations.
3. Excessive leading or lagging skew in a given track(s) after data readout if a persistent pointer is present during read or write operations.
4. Any valid pointers are present when end of data is detected on read or write operations.
5. Envelope check if accompanied by a persistent pointer or time sensor down during write operations.
6. Eight corrections in a given track without an intervening group of eight bit cells not needing correction on read operations only.

For nine-track NRZI operations: Write or loop write-to-read (LWR) has bits 6 and 7 on.

In read or read backward operations:

1. A single track and data check indicate the track in error.
2. Bits 6 and 7 with data check indicate an uncorrectable error pattern.
3. Bits 6 and 7 without data check indicate normal operation.

For seven-track operations: During seven-track read or read backward operations, the track in error byte is used for tape unit sense level control. The values are:

	TIE TU	Bus Out
Normal - no read VRC error	00	00
1st read VRC error	80	30
2nd read VRC error	40	10
3rd error returns sense level control to normal and cycle repeats.		

3803-2/3420

XB0300 Seq 2 of 2	2735746 Part Number	See EC History	845958 1 Sep 79	847298 15 Aug 83				
----------------------	------------------------	-------------------	--------------------	---------------------	--	--	--	--

© Copyright International Business Machines Corporation 1976, 1979, 1983



# HOW TO USE MAPS (Cont'd) - SENSE

00-007

## SENSE BYTE BITS NOT DEFINED IN MAPs

### SENSE BYTE 3

#### Bit 5 - 1600 bpi Set in TU

Set when the selected tape unit is in phase encoded (PE) mode.

#### Bit 6 - Backward

Set when the selected tape unit is in backward status.

### SENSE BYTE 4

#### Bit 0 - MP Hardware Error

Set whenever Microprocessor 1 (MP1) or Microprocessor 2 (MP2) hardware error occurs as defined in sense bytes 11 and 12.

#### Bit 1 - Reject Tape Unit

Set if the selected tape unit dropped READY during execution of a tape motion command.

#### Bit 2 - Tape Indicate

Set whenever the end-of-tape (EOT) marker is sensed during a forward tape operation.

#### Bit 5 - Loop Write to Read

Set when the last command was a loop write-to-read (LWR).

#### Bit 6 - Tape Unit Check

Set when unit check is present in the tape unit sense.

### SENSE BYTE 5

#### Bit 0 - New Subsystem

Is always zero on 3803-2/3420 subsystems.

#### Bit 1 - New Subsystem

Is always present on a 3803-2/3420 subsystem.

### SENSE BYTE 6

#### Bit 0 - Seven Track Tape Unit

Set when the selected tape unit is a 7-track unit. This bit is never active for tape unit Models 4, 6, and 8.

#### Bit 2 - Dual Density

Set when the selected 3420 Model 3, 5, or 7 is capable of 1600 and 800 bpi operations or the selected 3420 Model 4, 6, or 8 is capable of 6250 and 1600 bpi operations.

#### Bit 3 - 3420 Not Set to 1600 bpi

Set to indicate the mode of the tape unit in the following manner:

Bit 3 ON:

Models	Mode
3, 5, 7	800 bpi, 9-track NRZI
4, 6, 8	6250 bpi

Bit 3 OFF:

Models	Mode
3, 5, 7	1600 bpi
4, 6, 8	1600 bpi

Bit 3 is always ON for 7-track tape units.

#### Bits 4 through 7 - Tape Unit Model Identification

Indicate the tape unit model as follows:

Model	3	4	5	6	7	8
Bit 4	0	1	0	1	0	1
Bit 5	0	0	1	1	1	1
Bit 6	1	1	0	0	0	0
Bit 7	1	1	0	0	1	1

### SENSE BYTE 8

#### Bit 5 - Slow Begin Read Back Check

Present only if Start Read Check (Byte 5, Bit 5) is ON and is used as a modifier for field replaceable unit (FRU) finding.

#### Bit 7 - Velocity Retry/Restart

Present when:

1. Retry was necessary on initial Velocity Check on a write operation.
2. A single byte of noise occurred during a NRZI read delay.

**Note:** This bit is not an error.

### SENSE BYTE 9

#### Bit 4 - 6250 Tape Control

Present when the tape control has the capability to read and write 6250 bpi code.

#### Bit 7 - Tape Control Reserved

Present when the tape control is in reserved status.

3803-2/3420

<b>XB0400</b> Seq 1 of 2	<b>2735747</b> Part Number	<b>See EC History</b>	<b>845958</b> 1 Sep 79	<b>846927</b> 20 Jun 80	<b>847298</b> 15 Aug 83			
-----------------------------	-------------------------------	-----------------------	---------------------------	----------------------------	----------------------------	--	--	--

© Copyright International Business Machines Corporation 1976, 1979, 1980, 1983

00-007

**INSTRUCTIONS:** Determine if sense data is available. Use the sense analysis table and compare with the sense data presented. If there is a comparison, go to the MAP location listed. If there is a single tape unit failure, use the tape unit MAP location. If not, or if in doubt, start with the tape control MAP location. If sense data is not available, try to locate the symptom in the Symptom Analysis table, or go to 00-010. If sense data is available, try to locate the failing symptom in the symptom analysis table, then go to the MAP location. If in this index, or if the location given in this index fails to fix the problem, **ALWAYS** go to Section 00-010, Sequence 1 and follow the procedures given.

SENSE ANALYSIS			
PRIME SENSE	SUPPORT SENSE	TAPE CONTROL MAP PAGE	TAPE UNIT MAP PAGE
Byte 0, Bit 0 Command Reject		15-020	5A-000, Models 3, 5, and 7 5B-000, Models 4, 6, and 8
Byte 0, Bit 1 Intervention Required	READY Condition NOT READY Condition	15-010 15-090	15-010 2A/2B-000
Byte 0, Bit 2 Bus Out Check	Nothing Byte 4, Bit 0 ALU hardware error	15-030 13-000	Not Applicable Not Applicable
Byte 0, Bit 3 Equipment Check	Byte 6, Bit 1 Write Current Check	15-090	15-090
Byte 0, Bit 3 Equipment Check	Byte 7, Any Bit Any Tape Unit Check	15-090	15-090
Byte 0, Bit 3 Equipment Check	Byte 8, Bit 3 Early Begin Readback Check	17-100	5A-000, Models 3, 5, and 7 5B-000, Models 4, 6, and 8
Byte 0, Bit 3 Equipment Check	Byte 8, Bit 4 SAGC Check	16-220	5B-000
Byte 0, Bit 3 Equipment Check	Byte 10, Bit 7 Velocity Check	16-180	6A-000, Models 3, 5, and 7 6B-000, Models 4, 6, and 8
Byte 0, Bit 3 Equipment Check	Byte 10, Bit 0 Command Status Reject Byte 23, Any Bit FRU Byte - ALU2	16-160	16-160
Byte 0, Bit 3 Equipment Check	Byte 10, Bit 2 Control Status Reject Byte 23, Any Bit FRU Byte - ALU2	16-210	16-210
Byte 0, Bit 3 Equipment Check	Byte 10, Bit 3 No Block Detected on Write/WTM	16-190	5A-000, Models 3, 5, and 7 5B-000, Models 4, 6, and 8
Byte 0, Bit 3 Equipment Check	Byte 10, Bit 4 Dynamic Reversal	16-200	6B-000, Models 4, 6, and 8
Byte 0, Bit 3 Equipment Check	Byte 10, Bit 5 Tach Start Fail	16-170	16-170
Byte 0, Bit 3 Equipment Check	Byte 11, Any Bit ALU1 Hardware Error	16-XXX	Not Applicable
Byte 0, Bit 3 Equipment Check	Byte 12, Any Bit ALU2 Hardware Error	16-XXX	Not Applicable
Byte 0, Bit 4 Data Check		14-000	5A-000, Models 3, 5, and 7 5B-000, Models 4, 6, and 8
Byte 0, Bit 5 Overrun		15-040	5A-000, Models 3, 5, and 7 5B-000, Models 4, 6, and 8
Byte 0, Bit 6 Word Count Zero		15-050	Not Applicable

SENSE ANALYSIS			
PRIME SENSE	SUPPORT SENSE	TAPE CONTROL MAP PAGE	TAPE UNIT MAP PAGE
Byte 0, Bit 7 Data Converter Check		15-070	Not Applicable
Byte 1, Bit 7 Not Capable		15-060	15-060
Byte 5, Bit 3 ID Burst Check		17-050	5A-000, Models 3, 5, and 7 5B-000, Models 4, 6, and 8

SYMPTOM ANALYSIS		
SYMPTOM	TAPE CONTROL MAP PAGE	TAPE UNIT MAP PAGE
Channel Interface Checks with ALU hangs or loops on CE panel	13-000	Not Applicable
Load failures	Not Applicable	2A-000, Models 3, 5, and 7 2B-000, Models 4, 6, and 8
Meter problems	18-060	18-060
Picking/Dropping Records	15-200	15-200
Power Checks	11-000	1A-000, Models 3, 5, and 7 1B-000, Models 4, 6, and 8
Read Errors (a single permanent read error)	Not Applicable	00-011
Reset Problems	13-000	Not Applicable
Runaway Problems	13-000	5A-000, Models 3, 5, and 7 5B-000, Models 4, 6, and 8
Tape Switch Problems	18-010	18-010
Thread Failures	Not Applicable	2A-000, Models 3, 5, and 7 2B-000, Models 4, 6, and 8
Unload Failures	Not Applicable	4A-000, Models 3, 5, and 7 4B-000, Models 4, 6, and 8
Window Fails to go Down	Not Applicable	4A-000, Models 3, 5, and 7 4B-000, Models 4, 6, and 8
Window Fails to go Up	Not Applicable	2A-000, Models 3, 5, and 7 2B-000, Models 4, 6, and 8
Tape Motion and Rewind	Not Applicable	3A-000, Models 3, 5, and 7 3B-000, Models 4, 6, and 8

3803-2/3420

<b>XB0400</b> Seq 2 of 2	<b>2735747</b> Part Number	<b>See EC History</b>	<b>845958</b> 1 Sep 79	<b>846927</b> 20 Jun 80	<b>847298</b> 15 Aug 83		
-----------------------------	-------------------------------	-----------------------	---------------------------	----------------------------	----------------------------	--	--



<b>Note:</b> For information or assistance for use of the CE panel, refer to MAP 12-010.		
<b>Always</b> start with Seq 1 and follow the procedure in sequence unless directed otherwise. <b>Remember</b> to END all problem or maintenance calls by going to MAP 00-030.		
Seq	Condition/Instruction	Action
1	Is the problem definitely isolated to a single tape unit? If there are any doubts, interchange the signal cables with a tape unit that is working.	Go to 00-040.
2	Is the TCU or drive hung in the failing condition? (ALU1 or ALU2 not at 7FF)	Go to Seq 4.
3	If not:	Go to Seq 6.
4	<b>Note:</b> If error condition is still being held by subsystem, do not take tape control offline or reset system.  Turn the Display Select switch to IC and display both ALUs with the ALU1/ALU2 switch. Are both ALUs at 7FF?	Go to Seq 6.
5	If not:	Go to Seq 12.
6	Does the symptom indicate: 1. An access problem or 2. Device Busy	<b>Note:</b> Problem is assumed to be in the communicator or switch. Go to 18-000 for 1x8. Go to 18-010 for all other configurations.
7	Is sense information available?	Go to 14-000 for manual analysis or run OLT Section RO, WR.
8	Is there a permanent read error on a single reel of tape?	Go to 00-011.
9	Does the subsystem fail to power up, or is it possible the random failures may be due to power supply ripple or regulation?	Go to 11-000. If problem is not resolved there, return to Seq 10.
10	Does more than one tape unit run away?	Go to 13-000.
11	Is the subsystem picking or dropping records? Obtain customer's input and output tapes from the failing job.	Go to 15-200.

Seq	Condition/Instruction	Action
12	Do any of the following symptoms occur? <b>Note:</b> Red light halts may occur with panel enabled and Control Check stop on when powering up the subsystem. Do not troubleshoot these symptoms.  1. Control Check red lights from running in Error Stop Mode (refer to 12-010). 2. ALU hang or loop (ALU1 or ALU2 not equal to 7FF).  <b>Note:</b> If either ALU fails to indicate '7FF' and there are no apparent errors, either offline or online, the trouble may exist in the indicator circuits. If ALU1 is incorrect, replace B2G2. If ALU2 is suspect, replace A2J2. These cards can be bad and the lamps test good. Be aware that an indicator failure may not be noticed, and, in conjunction with an actual machine malfunction, could make trouble diagnosis very difficult.  3. Wait time out or condition code error. 4. Channel red light or channel error logout. 5. Channel Busy.	If the machine is in the failing loop, perform steps a through h; otherwise, go directly to 13-000.  a. Turn the Panel Enable switch on, set the ROS Mode Switch to Norm, and operate the Set ROS Mode switch.  b. Set the ALU1/ALU2 switch to ALU1, display Bus In and Bus Out with the Display Select switch, and record the Bus (lights 0-7) and Tags (lights 8-11) for the channel.  c. Turn the Display Select switch to HI ROS then LO ROS and record the Request and Busy indicators (lights 8-11).  d. Set the ALU1/ALU2 switch to ALU2, display both Bus In and Bus Out, and record the Bus and Tags for the device interface.  e. Set the ROS Mode switch to Step and operate the Set ROS Mode switch.  f. Operating the Start or Step switch, step through several addresses and record them for ALU2. Then select ALU1 with the ALU1/ALU2 switch and record several of those addresses.  g. If ALU1 is locked at IC address 301 or 302, go to Step h. and perform those actions; otherwise, proceed directly to MAP 13-000 without disturbing the failure.  h. Referring to Section 12-010, function number 16, display the LSRs for both ALUs. Go to MAP 13-000.
13	Are there extra or missing interrupts?	Go to 18-050.
14	Is there a usage meter problem?	Go to 18-060.
15	Is the system, or at least a partition, available for OLTEP/OLTSEP?	Go to Seq 18.
16	Is the tape control available for offline analysis?	Go to 12-000.

Seq	Condition/Instruction	Action
17	While awaiting subsystem availability:  1. Define channel command word (CCW) chains. 2. Define mode and byte count. 3. Define failing paths. 4. Go to 14-000 with sense and determine most probable cause. 5. If ALU failure is possible, Enable CE Panel, set ROS mode to STOP, and turn on control check stop. Try to get one failure in each ALU. 6. Go to Seq 15. <b>Note:</b> ALU error in stop mode will destroy customer's job. Refer to MAP 19-000 for the card layout and functional package.	
18	Using the 6250 bpi prewritten tape run the read only diagnostics until the first error occurs. Enter: r 01, 'xxx/3420/fe,ext=wz/' Repeat for tape unit of like mode or density to ensure that a single tape unit is not failing. Do tape units run without error?	Go to Seq 20.
19	Run 3420 section RO, WR after each failure in order to get sense analysis. Enter: r 01, '/3420ro,wr/'  (Sense is stored and used automatically by ro,wr. section of test. Sense is cleared by 'ext=/' if manual entry of sense into ro,wr is used.) Does OLTs printout resolve the problem?	Return subsystem to customer.
20	Run the 3420 write-read OLTs: Mount good scratch tape. Enter r 01, '/3420/fe,ext=/' After error occurs, run section ro,wr as in Seq 19. Does OLTs printout resolve the problem, assuming failure occurs?	Return subsystem to customer.
21	Did failure occur?	Rerun write-read OLTs several times, trying customer's failing tape. Go to Seq 17 and attempt to determine the most probable FRUs. Go to Seq 22.
22	Did OLTs printout resolve the problem?	Return subsystem to customer.
23	If not:	Go to procedure specified by FRU printout or MANUAL SENSE, 14-000. Verify that offline sense matches OLT.

3803-2/3420

XB0500 Seq 1 of 2	2735748 Part Number	See EC History	845958 1 Sep 79	846927 20 Jun 80	847298 15 Aug 83		
----------------------	------------------------	-------------------	--------------------	---------------------	---------------------	--	--

Clean read/write head, cleaner blade, and capstan. Check -4 and +6 voltages. Degauss R/W and erase heads.

When checking tape offline, be sure to read tape in both directions. Set the CE panel error check stop switches to the On position to allow display of pertinent error information.

Tape will stop when a tape mark is read. It may be necessary to press START after the tape mark is read, since there can be tape marks on the beginning of tape.

If the failure cannot be recreated, log all available data for future reference. Include the following in the intermittent trouble log:

1. Address of tape unit on which tape was written.
2. Address of tape unit on which tape failed to read.
3. Tape reel number.
4. Console messages defining failure.
5. Error log output for the interval involved.

In addition, ensure that proper error recovery programming is used, mode and density assignments are correct and tape cleaner blades are not worn out. Notify account manager of heavy oxide accumulation, worn tape, external sources of contamination, or any other factor detracting from tape reliability. Initiate corrective action with the customer.

If the read failure occurs on only one tape unit, there may be a tape read problem on that unit. If only two tape units are checked, the tape unit that does not fail to read the tape could be the one that wrote it. Try two more tape units to confirm your diagnosis.

If more than one tape unit fails while reading a tape, a bad record is probably present. If the tape reads properly only on the unit that wrote the tape, check that unit for proper mechanical skew and ensure the amp sensors are adjusted correctly.

Retain the failing tape until you have identified the problem. Some conditions that could cause a single tape unit to fail to read a given tape are:

1. Incorrect amp sensor adjustment.
2. Dirty, trenched, or defective read/write head.
3. Damaged, dirty, or glazed capstan.
4. Contaminated air bearing ports.
5. High speed rewind plunger/autocleaner not retracted.
6. Faulty capstan motor.
7. Incorrect pneumatic adjustments.
8. Poor tape tracking.
9. Excessive mechanical skew.
10. Defective read head card.
11. Incorrect power supply voltages or ripple.
12. Slipping capstan.

3803-2/3420

<b>XB0500</b> Seq 2 of 2	<b>2735748</b> Part Number	<b>See EC History</b>	<b>845958</b> 1 Sep 79	<b>846927</b> 20 Jun 80	<b>847298</b> 15 Aug 83		
-----------------------------	-------------------------------	-----------------------	---------------------------	----------------------------	----------------------------	--	--

© Copyright International Business Machines Corporation 1976, 1979, 1980, 1983

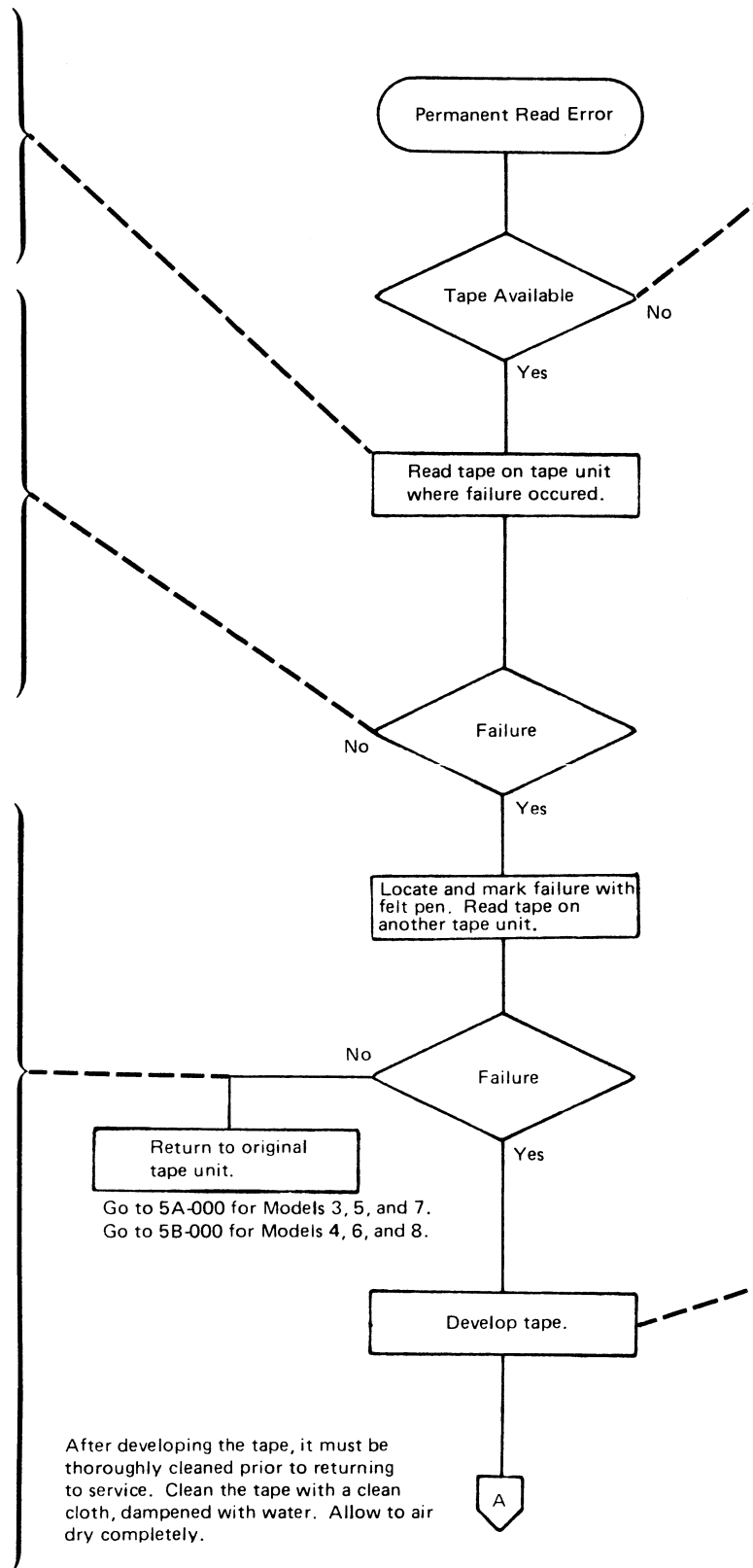

Customer cooperation is important when analyzing permanent read errors. Request customer to furnish the following:

1. Failing tape (ask customer to mark tape reel at approximate area of failure).
2. Address of tape unit on which tape was written.
3. Address of tape unit on which tape failed to read.
4. Job on which failure occurred.

**Tape Developing Procedure**

**Purpose:** Gives CE a way of visually examining information recorded on a section of magnetic tape.

**Materials Needed:**

- Developing solution (P/N 453522)
- "Low-tack" transparent tape (See Note 1.)
- Piece of clear plastic (such as old microfiche card, loose-leaf page cover, etc.)
- Felt-tip pen
- Flat surface (small table, etc.) which can be moved to area in front of tape unit
- Lint-free cloth (P/N 2108930) dampened with water

**Procedure:**

- Mount failing tape, without cartridge, and read to error. This is done from 3803 CE panel (offline) or using "FRIEND" (OLT T0200A) or customer utility such as "ditto," etc. (online).
- When failure occurs press reset on drive and open front door. While holding "cartridge-present" button pressed, manually bottom tape in right column. This shuts off pneumatics.
- Open vacuum door and put small mark on bottom (non-oxide) side of tape on each side of R/W head.
- Carefully remove enough tape to reach the flat surface.
- Shake the developing solution, then immerse a small loop of the magnetic tape into solution (oxide side in). Use the felt-tip pen mark to determine suspect area. Rock tape back and forth two or three times being careful not to drag on bottom of can.
- Remove tape from solution and allow liquid to evaporate while still rocking tape gently back and forth.
- Lay tape, oxide up, on the flat surface and use a small piece of transparent tape at each end of developed area to hold in place.

- Tear off an appropriate length of transparent tape and carefully press it onto the developed tape. Try to avoid air bubbles, etc.
- Gently lift the transparent tape back off (peel it at an angle to avoid damage) and place on the clear plastic.
- The plastic with developed image may now be viewed directly or under the microfiche viewer. Since the microfiche viewer magnifies X30 be sure to divide any measured distance by 30.
- Clean the magnetic tape thoroughly using the cloth dampened with water. Allow it to air dry before rewinding and returning tape to customer for his cleaning procedure.

**Caution: Any foreign material left on the tape will damage the drives.**

**Conclusions:** Some of the more common problems which will be detected by tape developing are:

1. Partially erased records before an ERG. Usually caused by a glazed capstan.
2. Noise in gap (defective erase head, etc.).
3. Short gaps (indication of tape motion problem)
4. Damaged tape (oxide voids, etc.).

See the following examples.

**Note:** The use of any other than "low-tack" transparent tape is discouraged as it may remove oxide or leave adhesive on tape.



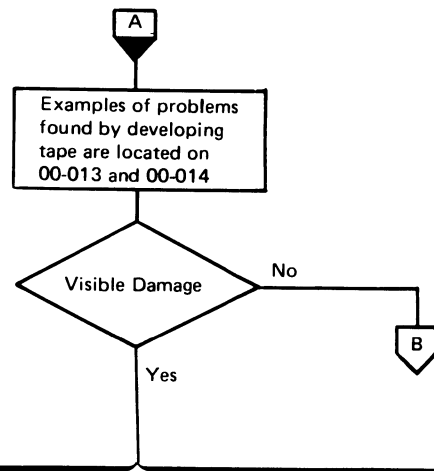

**Analysis of Damaged Tape Errors**

Tape damage at the point of a permanent read error is not necessarily the only cause of the error read. The block could have been written over previously damaged tape, correct machine operation and programming should have prevented this. Consider the following:

1. Can the machine detect write errors?
2. Does the program handle write errors?
3. Did most or all of the errors occur immediately following the last SYSGEN?

Analyze the damaged area and its relationship to the adjacent blocks by developing tape. Try to identify patterns by analyzing several permanent errors. When developing tape, look for:

**Short Gap:** A slightly shortened gap within one block of the damaged spot indicates a write error was properly detected but no erase record gap (ERG) was programmed. If backward creep occurred during several attempts to write at the same spot, the damage could move outside the block and eliminate the write error. The previous IBG may now be so short that the block cannot be read, or part of the preceding block may have been erased.

**Tape Damage in Erased Gap Area:** If a Write error was detected and the tape has properly erased over the damaged area, check the ability of read routine to handle noise blocks.

**Tape Damage at End of Block (Block Appears to be Too Short):** A Write error was detected, but tape liftoff due to tape damage prematurely stopped the Backspace operation. An Erased gap follows the remaining partial block. A contaminated Read/Write head may aggravate this condition.

**Tape Damage in Beginning Zeros Burst (PE Only):**

An undetected write error caused a permanent read error. This error occurs on emulators where rewrite in place causes the block to creep forward until the damage is in the very beginning of the block, which may prevent detection of the write error.

**Tape Damage in Ending Zeros Burst (PE Only):**

Occurs less often than preceding problem. The permanent read error occurs here during a read backward operation.

**Note:** Errors in the beginning and ending zeros burst can be overcome if the program attempts to read the error block in the opposite direction.

**Tape Damage Consists of Small Spot or Oxide Void in One or More Tracks:** Defect may have occurred after tape was written. The tape control should be able to correct for a void within a single track. Run 3803-2/3420 OLTs, section G. Verify single track correction capability.

**Tape Damage in Middle of Data:** Check the tape control ability to detect write errors. Check for unconventional programming.

All the problems listed under Damaged Tape Errors can be reduced by convincing the customer to dispose of bad tapes. Well adjusted tape units, complemented by good programming, should run with few permanent read errors, even on damaged tape. Throughput may be greatly reduced, but failures should be temporary.

Since permanent read errors can also result from damage after tape is written, emphasize careful tape handling.

3803-2/3420

<b>XB0600</b> Seq 1 of 2	<b>2735749</b> Part Number	<b>See EC History</b>	<b>845958</b> 1 Sep 79				
-----------------------------	-------------------------------	-----------------------	---------------------------	--	--	--	--

**Analysis of IBG in Developed Tape**

1. A short interblock gap (IBG) is caused by tape slippage at the capstan, or a problem in the IBG counter circuits.
2. Tape slip (while stopping tape) can cause problems other than a short IBG. For example, when performing a write skip operation, the tape is backspaced over the defective area on tape, moved forward during an erase record gap operation, then moved forward again to write the defective record correctly. If the tape slips during the backspace operation (goes too far backward), the write head may partially erase the previous record. (In 6250 mode the IBG is only 0.3 inches (7.6 mm) wide.)  
In the event that this problem is suspected, do the following:
  - a. Develop a length of tape after performing the above operation a number of times. The distance from one record to the next should be 3.9 inches, (99.0 mm). If the distance is 3.8 inches, (96.5 mm) or less, the tape has slipped and may have caused the previous record to be partially erased. This condition might be seen as a fuzzy area at the end of the previous record.
  - b. Run diagnostic section 3420 W (OLTs). This diagnostic indicates if tape is slipping. The readings should be as close to 0.301 inches, (7.6 mm) (6250 mode) or 0.6 inches (15.2 mm) for Models 3, 5, and 7 as possible. Readings very far from this standard could indicate glazed or dirty capstans. (See 85-004 for cleaning procedure.) Clean capstans and rerun diagnostics to verify fix. Diagnostic failures on Model 8 drives after cleaning may be caused by the vacuum hose disconnected from the capstan motor.
3. Information or noise written in IGB. Several causes are:
  - a. Erase head polarity reversed: Polarity is correct when top wire is a plus voltage with respect to bottom wire. Incorrect polarity can cause a single unwanted pattern in the IBG.
  - b. Tape written on another manufacturers system: If tape causing errors was written on a non-IBM system, verify amp sensors and skew adjustments.
  - c. Open erase head: If the erase head is open, tape will be erased in longitudinal stripes, with a hazy area between the write head tracks.
4. When viewing a tape block on the microfiche viewer, you may see extreme cases of bit packing, due to velocity variations while writing.
5. If phase encoded (PE), examine the zeros bursts (the grey high frequency area at both ends of the block) and the ones marker (the first straight dark line through all tracks). The beginning and ending burst should be the same length. Partial blocks can be caused by failing IBG detection circuits or excessive lifting of tape from the read/write head.

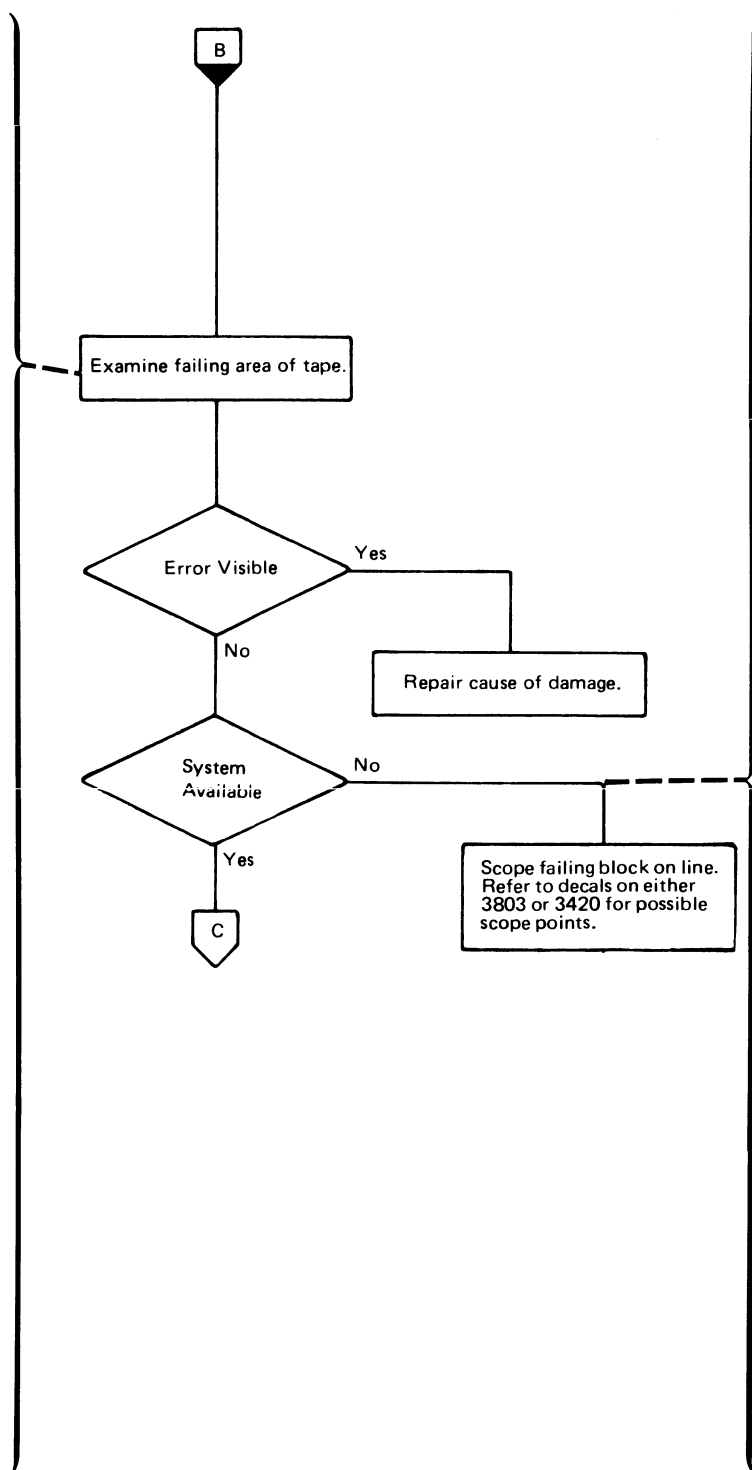

**Scope Failing Block Offline**

- Scope a permanent read error to locate the failure within the block and determine the cause. Proceed as follows with the tape control offline:
1. Locate the failing block.
  2. Loop on the failing block:
    - a. Read forward-backspace on forward read failures.
    - b. Read backward-forward space on backward read failures.

**Note:** The command sequence can be slowed down by increasing the go down time with the CE panel. This will reduce customer tape wear.
  3. Double sync the scope by arming the sweep with the failing command and triggering the sweep with Read Condition. Display the entire block on channel A by scoping the device Bus In, digital data (any track).
  4. On channel B, observe the error latch turn-on and its timing relationship to the entire block.  
**Note:** Be sure to observe the first error indication, and not an error resulting from the initial error.
  5. Now that you know approximately where the error occurs, make a general analysis of the block, looking at all tracks for the following possible causes:
    - a. Incorrect block format: Digital read data is generated in the 3420, so analog data must be scoped at the read card test points at the front of the 3420 (Models 3, 5, and 7 only; and located on the rear of Models 4, 6, and 8). While looping the failing record with the 3803, scope the failing record using a suitable sync in the 3420.
    - b. Amplitude variations occurring at the beginning of the block (bit packing). See 5A-115 or 5B-025.
    - c. Signal Dropout: A good technique for locating single track failures is to ground the read buses one at a time and observe the error indicators. If after grounding a read bus the only failure remaining is a dead track indication, that track is the one causing the error. If error records read correctly on other tape controls, the problem may be track alignment or a faulty card in the failing tape control.

- d. If amplitude appears lower in some individual tracks, check the drive that wrote or read this tape for a possible magnetized cleaner blade. See 08-390 for Cleaner Blade Gauss Check and Degauss procedure.
- e. If skew appears excessive, check the tape unit that created the record for faulty capstan tracking and mechanical skew. If a NRZI tape unit check electrical skew and make sure that the movable tape guides are operating correctly. The tape guides will retract intermittently if the high speed rewind solenoid is faulty. Also a defective air regulator can cause air bearing pressure to fluctuate causing skew.
- f. Check the tape unit that created the failing record for a bad write card.

If the failure cannot be analyzed by offline scoping, go to **D** above. **DO NOT ERASE TAPE UNTIL THE ERROR HAS BEEN DEFINED.**

Figure 1. Signal Envelopes on Read

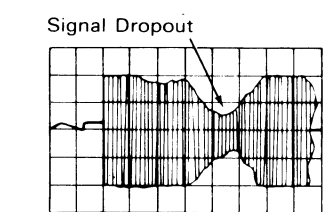

3803-2/3420							
XB0600	2735749	See EC	845958				
Seq 2 of 2	Part Number	History	1 Sep 79				

**Scope Failing Block On Line**

Use the FRIEND program to scope permanent read errors online:

**Note:** Don't use channel command word (CCW) chains. Reading the bad record breaks the chain.

1. Locate the failing block with the control unit offline.
2. Set up a program loop to read-backspace or read backward-forward space, whichever is applicable.
3. By altering the channel command word (CCW) byte count, the Command Out response to Service In will set the Stop trigger in the tape control at any byte chosen. Sync external on the Stop trigger to examine any portion of the block in detail.

**Note:** Detailed observation of a PE block is difficult due to normal distortion of the PE signal and the high amount of skew the PE detection circuits can tolerate. Examine several tracks at comparable points, looking for noticeable differences in levels and waveforms. A record containing excessive phase shift is usually indicated by multi-track error (MTE) or read write register (R/W Reg) vertical redundancy checks (VRC). Check the tape unit that wrote the tape for a possible defective write driver. Make same observations as stated in Scope Failing Block Offline, step 5.

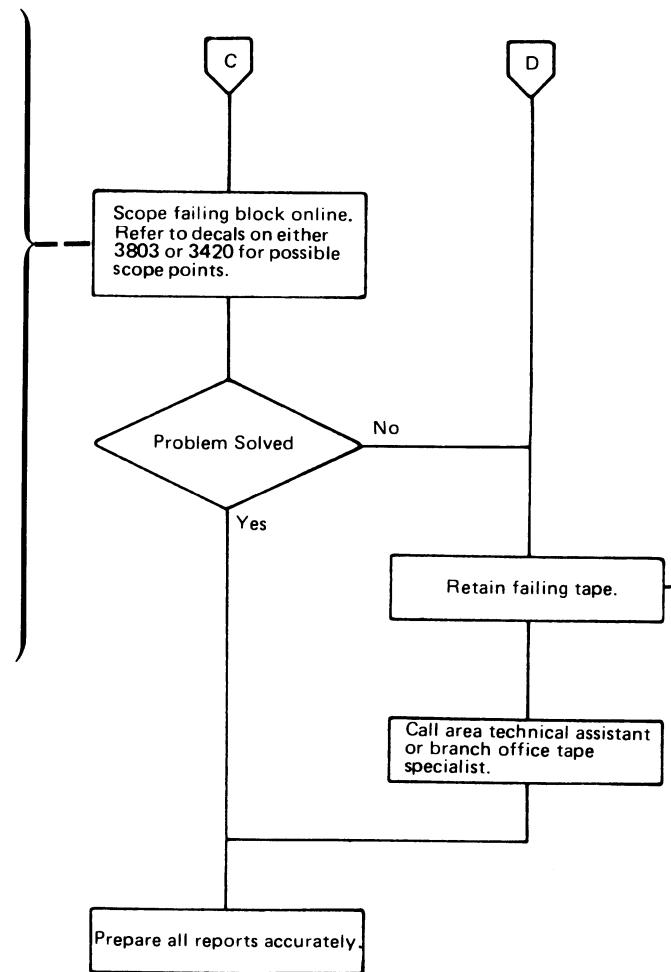

If cause of the permanent read error cannot be determined, save the tape and any information gathered for use by branch office or area tape specialist. A permanent read error can cost the customer considerable reconstruction and rerun time, especially if the tape was written a month or more prior to the time of reading it. **There should be no undefined permanent read errors.**

XB0610	4169706	See EC	845958					
Seq 1 of 2	Part Number	History	1 Sep 79					

From: 00-011

The following pages are a guide to analyze the failing tape after developing. This page and 00-014 show some examples of tape related problems, but not all that could occur.

Figure 1A. Magnetized R/W Head

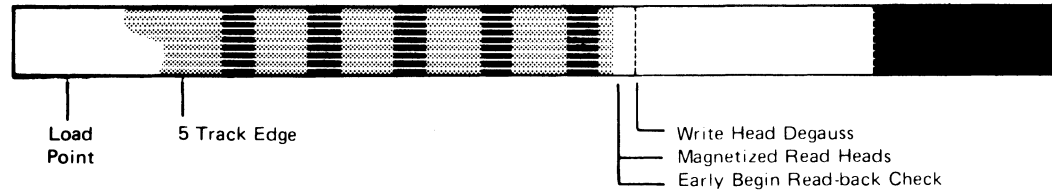

This error is a result of magnetized read heads. Notice where the read heads stop and where the write heads are degaussed. Figure 1A shows a failure that occurred while the customer was using the drive. If magnetized tools are used, or a resistance check is made on the head, be sure to degauss the transport before returning the tape unit to the customer.

Figure 1B.



After identifying the drive, another scratch tape was mounted and the same characteristics resulted as shown in Figure 1A.

Figure 1C.

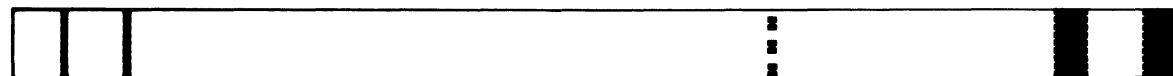

Results after the transport was degaussed.

3803-2/3420

XB0610	4169706	See EC	845958					
Seq 2 of 2	Part Number	History	1 Sep 79					

© Copyright International Business Machines Corporation 1976, 1979

Figure 2. Tape Lift

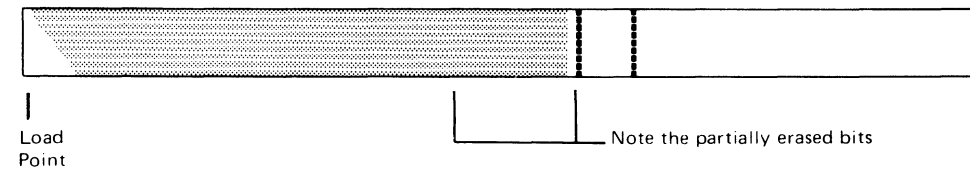

This tape lift came from a different customer account with the same tape problem. However, this failure indicated a permanent read error after the tape had been used at least once. This could be a big problem in most accounts if a master file has to be re-created. The magnetized heads will decrease the signal strength each time the tape passes over the heads.

Figure 3. Tape Lift While Writing A Tape Mark

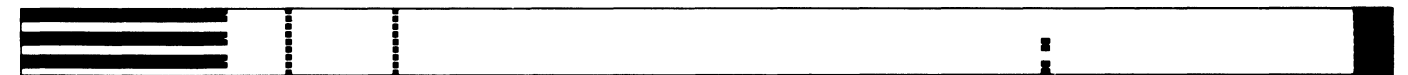

Tape lift causing a no beginning-of-record (BOR) write tape mark (WTM) equipment check. Notice the header label had no tape lift, indicating that the tape must have been dirty between the label and the tape mark, or possibly some debris came off the cleaner blade.

Figure 4. Tape Slipping (dirty capstan)

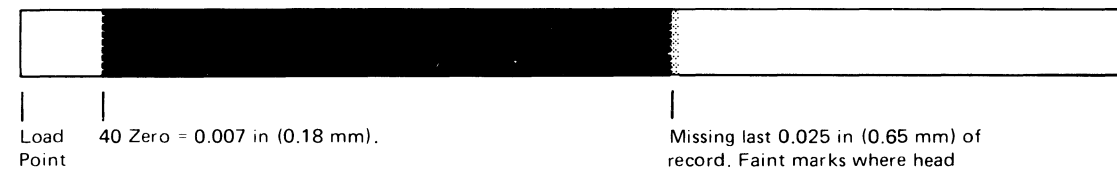

Tape slip during turn-around following a backspace rewrite. The preamble is good.

Customer is not keeping the capstan clean.



From: 00-013

Figure 5. Creased Tape Error (237 ABEND Error)

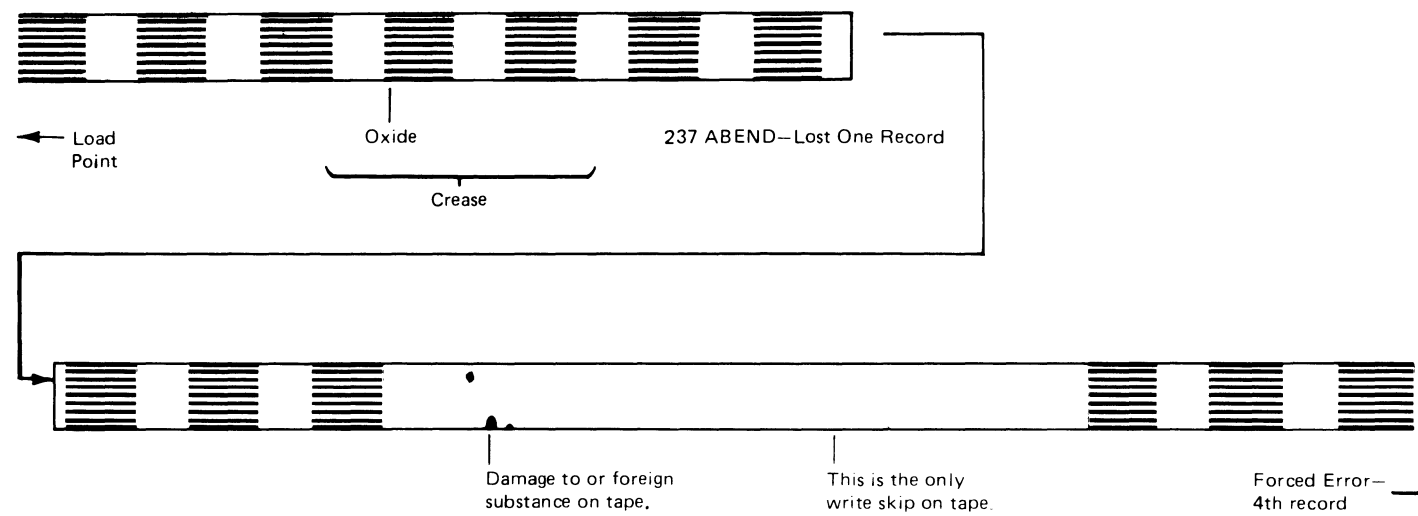

One record lost when compared to the trailer label count. This can be mistaken for one write error when the tape is created. It is actually caused by the tape crease. If the crease is smoothed out, the count is corrected. Tape crease was caused by excessive capstan to stubby bar clearance.

Figure 6. Contaminated Tape

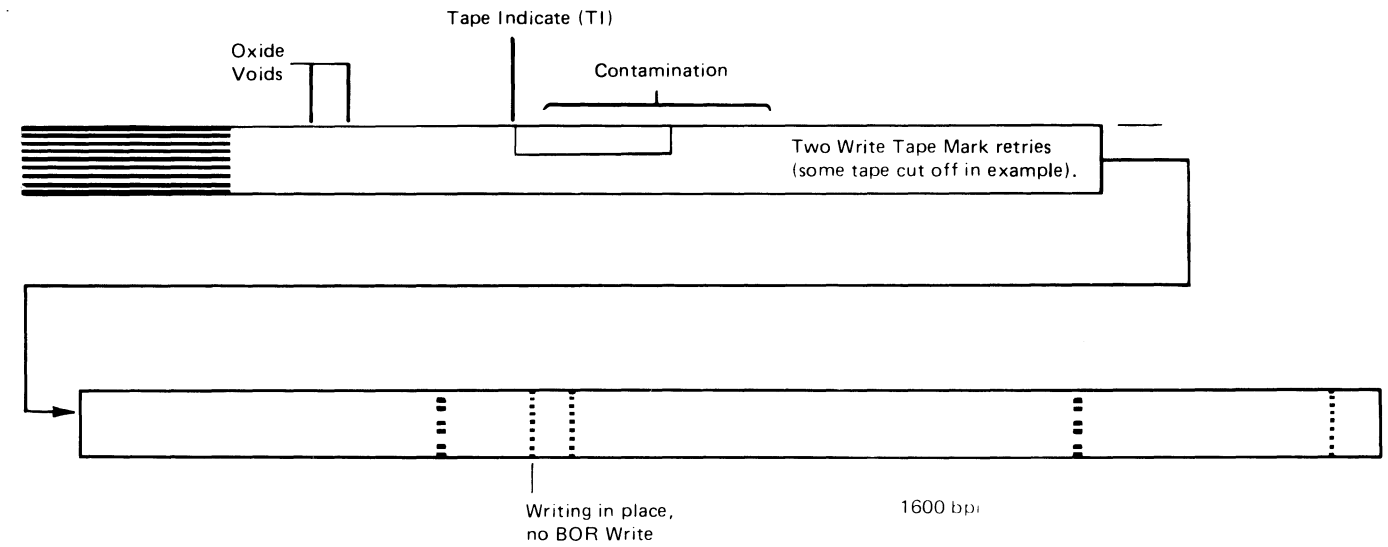

This tape was marginal before this error occurred. Oxide voids caused by contaminates sticking to the next wrap, contamination from the cleaner blade, caused the failure illustrated.

Figure 7. 7-Track Tape Lift or Defective Write Card

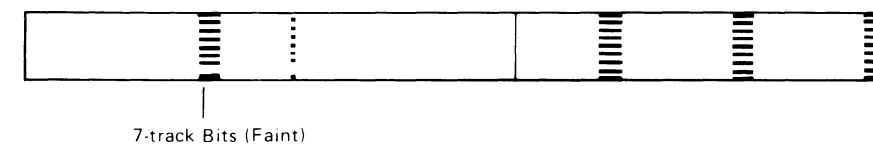

Seven track tape lift, caused faint 7-track bits. If the write head card is defective, nothing is visible in this track.

3803-2/3420

<b>XB0620</b>	<b>8492598</b>	<b>See EC</b>	<b>845958</b>	<b>847298</b>				
Seq 1 of 2	Part Number	History	1 Sep 79	15 Aug 83				

© Copyright International Business Machines Corporation, 1976, 1979, 1983

<b>From all MAPS</b>		
Always check for conditions in the order indicated by the Seq column.		
<b>Note:</b> If a logic board has been replaced, refer to the following ALD pages to ensure that the logic board has the correct jumper locations: <ul style="list-style-type: none"> <li>• 3420—ALD A6106</li> <li>• 3803—Start on ALD AA005</li> </ul>		
<b>Always</b> start with Seq 1 and follow the procedure in sequence unless directed otherwise. <b>Remember</b> to END all problem or maintenance calls by going to MAP 00-030.		
Seq	Condition/Information	Action
1	Is the problem fixed?	If cleaning the tape path fixed the problem check the condition of the cleaner blade (see 08-390). If unit is fixed return to the customer.
2	Is this the first time through this map on the original problem?	Go to Seq 4.
3	If not:	Go to Seq 15.
4	Check the voltages and ripple tolerances (see 08-570). Are they within specifications?	Go to Seq 6.
5	If not:	Adjust or repair as necessary.
6	Have any of the following ABEND messages been reported? 137 237 413 613	Refer to 00-035 and review Possible Causes. If 00-035 does not fix the problem, return to Seq 7 on this page.
7	Is there a Read/Write problem?	Go to Seq 9.
8	If not:	Execute the failing command(s) using the tape control unit or OLTs. If this symptom is different reenter START 1; otherwise go to Seq 15.
9	Have the Read/Write head and the tape cleaner blade been degaussed?	Go to Seq 12.
10	If not:	Refer to 08-390 and do the degaussing procedure. Return to Seq 11.
11	Did this fix the problem?	Return the unit to the customer.
12	Has tape been developed as described on 00-011?	Go to Seq 14.
13	If not?	Follow the procedures starting on 00-011 and develop the tape. Return to Seq 14.
14	Run OLTs test 3420 BA, BB using Stress tape P/N 1848621 (Brach office tool). See 3420 OLT User Guide form number D99-3420A-6 or later for operating instructions. Does the problem still exist?	Go to Seq 15.

Seq	Condition/Information	Action
15	Go to Action column.	A. Recheck symptoms. B. Reseat suspected FRUs (cables, cards, etc.). C. Review the sense information from OBR/SDR, OLTs or EREP. D. Review the following for possible fixes: <ul style="list-style-type: none"> <li>• Field Feedback (00-050)</li> <li>• Retain</li> <li>• Service Aids</li> <li>• ECA lists</li> </ul> E. If problem still exists call for assistance.

3803-2/3420

<b>XB0620</b> Seq 2 of 2	<b>8492598</b> Part Number	<b>See EC History</b>	<b>845958</b> 1 Sep 79	<b>847298</b> 15 Aug 83				
-----------------------------	-------------------------------	-----------------------	---------------------------	----------------------------	--	--	--	--



## ABENDS-THEORY

00-035

ABEND 137, 237, 413, 613, and 637 may be caused by missing tape marks and other conditions. (See charts).

Missing tape marks are caused by:

- Incorrect forward-backward ratio.
- Loss of signal amplitude causing a failure to recognize the tape mark.
- Excessive crosstalk, indicating that data is fed into a dead zone. Data on any track in a dead zone will prevent reading a tape mark correctly.

Crosstalk is caused by:

- Defective write card
- Defective read card
- Defective R/W head
- Poor tracking. If tracking is out of specifications go to Capstan Dynamic Alignment. The drive that wrote or read the tape, or both, could cause crosstalk.

If the failing tape is not available, write a tape on a working tape drive offline, and use that tape to check for crosstalk on the suspected failing drive.

### 137/637 ABEND

Machine Type	Possible Causes
3803	Defective 01A-A2N2 card.
3803	Defective 01A-B2F2
3420	Capstan tracking

### 237 ABEND

Machine Type	Possible Causes
3420	Large tape creases detected as gaps (check stubby bar clearance).
3420	Short records (80 characters) falling within a tape crease.
3420	Tape edge damage.
3420	E/C 443935 (6250)—Fix for short gap verification during backspace after a write error caused by erratic tape motion, not installed.
3420	R/W head forward-to-backward ratio is out of specifications.
3420	Tape sticking.
3420	Dirty capstan.
3803	Missing Suppress Out, intermittently breaking channel command word (CCW) chain, updating the count but not losing a record.
3803	Defective 01A-B3F2 Inbound tag card XC700.
3803	ECA079—Unexpected interrupt with status='00' from a non-two channel switch in multiple CPU 2X, 3X, 4X, installation.

### 413 ABEND

Machine Type	Possible Causes
3420	Defective T-A1C2 MST card.
3420	Defective T-A1H2 card
3420	Defective T-A1L2 card
3420	Reading 6250 tape in 1600 mode. E/C 443890—not installed, autocleaner sluggish.
3420 Models 4, 6, 8	E/C 735817—Delay Ready after rewind to allow autocleaner to return, is not installed.
3420	Damaged tape at load point.
3420	Contamination on the Read/Write head, or the capstan is dirty/glazed.
3803	Defective 01A-A2D2 MST card or defective 01A-A2E2 MST card.
3803	Broken CCW chain without Unit Check. Run an I/O software trace for more problem definition.
3803	ECA079—Prevent busy in middle of CCW chain, not installed.
3803	ECAs 118 and 123 not installed.

### 613 ABEND

Machine Type	Possible Causes
3803	Defective 01A-B2F2
3420	Tape tracking leaves a faint tape mark when existing files are updated because of overwriting the old EOF tape mark. The write heads are erasing the old tape mark.
3420/3803	UCW is plugged incorrectly. It should be plugged as shared.
3420	E/C 443935—Short gap engineering change not installed.
3420 Models 4, 6, 8	ECA073—Delay Ready after rewind to allow autocleaner to return, is not installed.
3420	Contaminated Read/Write head.
3420	Damaged tape at or near load point.
3420	Read/Write head forward-to-backward ratio not in specifications.
3803	Defective 01A-A2N2 card, extra tape mark. Defective 3168/2880 card, high speed buffer—data compare.
OS/VS2 R017	PTF 70751 not installed.

3803-2/3420

XB0650 Seq 1 of 2	4169691 Part Number	See EC History	845958 1 Sep 79	847298 15 Aug 83				
----------------------	------------------------	-------------------	--------------------	---------------------	--	--	--	--

© Copyright International Business Machines Corporation 1976, 1979, 1983

00-035

NOTES:

00-036

3803-2/3420

<b>XB0650</b> Seq 2 of 2	<b>4169691</b> Part Number	<b>See EC</b> <b>History</b>	<b>845958</b> 1 Sep 79	<b>847298</b> 15 Aug 83				
-----------------------------	-------------------------------	---------------------------------	---------------------------	----------------------------	--	--	--	--

© Copyright International Business Machines Corporation 1976, 1979, 1983

00-036





**SINGLE TAPE UNIT PROBLEMS**

**00-040**

From 00-010		
<b>DANGER</b> Allow fiber optics lamp to cool before checking, adjusting, or removing.		
<b>Note:</b> Inspect the fiber optics lamp. If lamp is not clear, clean or replace the lamp. (Turn lamp off for inspection).		
<b>Always</b> start with Seq 1 and follow the procedure in sequence unless directed otherwise. <b>Remember</b> to END all problem or maintenance calls by going to MAP 00-030.		
Seq	Condition/Instruction	Action
1	Is this a visual problem? (Visual problems are defined as power checks, load failures, tape motion problems, rewind problems, unload failures, tape runaway, or window operation.)	Go to Seq 9.
1A	Is this a meter problem:	Go to 18-060.
2	Is the tape unit dropping READY?	Go to 2A-000 for Models 3, 5, or 7. Go to 2B-000 for Models 4, 6, or 8.
3	Is the tape unit picking or dropping records?	Go to 15-200.
4	Is there a device selection problem, an erroneous Device Busy, or an abnormal system condition?	Go to Seq 16.
5	Obtain sense information from LOGREC, OLT run (3420 A-Z), a console printout, or from manual sense operations at the tape control. (For manual sense operation, see 12-000.)	
6	Is there an error from an OLT run indicating a tach parameter, tach asymmetry, start/stop, or interblock gap (IBG) and creep measurement problem? (OLTs 3420 T-Z)	Go to 6A-000 for Models 3, 5, or 7. Go to 6B-000 for Models 4, 6, or 8.
7	Does the sense information obtained by any method (see Seq 5) indicate an error condition?	Go to Seq 25.
8	If not:	Go to 5A-000 for Models 3, 5, or 7. Go to 5B-000 for Models 4, 6, or 8.
9	With the tape unit unloaded, is the File Protect light on, and the Power Check light off?	Go to Seq 11.
10	If not:	Go to 1A-000 for Models 3, 5, or 7. Go to 1B-000 for Models 4, 6, or 8.
11	Is the Load Check light on?	Go to 2A-000 for Models 3, 5, or 7. Go to 2B-000 for Models 4, 6, or 8.
12	Open the main machine door and pull the door interlock. Mount a tape and watch a thread and load operation. Also listen for audible indications of trouble. Does the tape unit thread, load, and become ready?	Go to Seq 14.
13	If not:	Go to 2A-000 for Models 3, 5, or 7. Go to 2B-000 for Models 4, 6, or 8.

Seq	Condition/Instruction	Action
14	With a write enable ring in place, is the File Protect light on?	Probable causes: • T-A1H2 (Models 3, 5, 7) • T-A1M2, K2 (Models 4, 6, 8) • File protect switch • Write enable relay card (located under right reel motor)
15	With the field tester installed, examine the loops in the stubby columns. Compare with pictures on 6A-010 for Models 3, 5, or 7 or 6B-150 for Models 4, 6, or 8. Are the loops in the stubby columns abnormal?	Repair abnormal condition as indicated on 6A-010 or 6B-150 and go to 00-030.
16	Using the field tester, observe forward, backward, high speed and low speed rewind, and start/stop operations. Do all operations appear to be normal?	Go to Seq 18.
17	If not:	Go to 3A-000 for Models 3, 5, or 7. Go to 3B-000 for Models 4, 6, or 8.
18	Are the unload and window down operations normal?	Go to Seq 20.
19	If not:	Go to 4A-000 for Models 3, 5, or 7. Go to 4B-000 for Models 4, 6, or 8.
20	Is the reported problem tape runaway?	Go to Seq 22.
21	If not:	Recheck symptoms.
22	Scope tape unit BUS IN for all tracks. See 5A-100 for Models 3, 5, or 7. See 5B-100 for Models 4, 6, or 8. <b>Note:</b> To be done in Write status.	
23	Is data present on tape unit BUS IN for any track?	Go to 3A-140 for Models 3, 5, or 7. Go to 3B-140 for Models 4, 6, or 8.
24	If not:	Go to 5A-000 for Models 3, 5, or 7. Go to 5B-000 for Models 4, 6, or 8.
25	Referring to sense charts on 00-005, examine sense data to determine its validity. Look for bits that should always be on or off, such as tape unit serial number, EC level, and features. Next, look for bits that make no sense, such as end-of-tape (EOT) and load point both on, 7-track unit and dual density both on, etc. Is the sense data valid?	Go to Seq 27.
26	If not:	Be sure known LOGREC problems have been corrected with program temporary fixes (PTFs), then change T-A1L2, T-A1K2, T-A1K6 and T-A1M2. Recheck the symptoms. If conditions remain unchanged, examine cables to I/O tailgate (A2N2 - A2N4) for defects.
27	Is Equipment Check (byte 0, bit 3) on?	Go to Seq 34.
28	Is Data Check (byte 0, bit 4) on?	If tape errors are predominantly on read backward, go to 85-004 and do capstan cleaning procedure, then go to 08-240. If problem persists, go to Seq 47.

Seq	Condition/Instruction	Action		
29	Is Intervention Required (byte 0, bit 1) on?	Go to Seq 51.		
30	Is Not Capable (byte 1, Bit 7) on?	Check that the failing tape was written at a density that the tape unit can read. If so go to 14-010 Seq 10.		
31	Is ID Burst Check (byte 5, bit 3) on?	Go to 5A-000 for Models 3, 5, or 7. Go to 5B-000 for Models 4, 6, or 8.		
32	Is Command Reject (byte 0, bit 0) on?	Go to 15-020.		
33	If not:	Other sense bits which turn on Unit Check in the status byte, such as Bus Out Check or Overrun, are not single tape unit problems. Recheck symptoms and sense information. Go to 00-010.		
34	Is Control Status Reject (byte 10, bit 2) on?	Go to 6A-160 for Models 3, 5, or 7. Go to 16-210 for Models 4, 6, or 8.		
35	Is Command Status Reject (byte 10, bit 0) on?	Go to 6A-160 for Models 3, 5, or 7. Go to 16-160 for Models 4, 6, or 8.		
36	Is Power Check or Airflow (byte 18, bit 0) on?	Go to 1A-000 for Models 3, 5, or 7. Go to 1B-000 for Models 4, 6, or 8.		
37	Is Reject Tape Unit (byte 4, bit 1) on?	Go to 15-090 for analysis of sense byte 7.		
38	Are any of the following bits ON?	This is a tape motion problem. Go to 6A-000 for Models 3, 5, or 7. Go to 6B-000 for Models 4, 6, or 8.		
	<b>Description</b>		<b>Byte</b>	<b>Bit</b>
	Early Begin Read Back Check		8	3
	Dynamic Reversal Error		10	4
39	Is SAGC Check (byte 8, bit 4) on?	Go to 5B-000.		
40	Is Tach Start Failure (byte 10, bit 5) on?	Go to 16-170, 6A-000, or 6B-000.		
41	Is No Block Detected on Write WTM (byte 10, bit 3) on?	Go to 5A-000 for Models 3, 5, or 7. Go to 5B-000 for Models 4, 6, or 8.		
42	Is the command in your failing CCW an Erase Gap or DSE command?	Go to Seq 45.		
43	Is ALU Hardware Error (byte 4, bit 0) on?	This is not a single tape unit oriented failure. Recheck symptoms and go to 00-010.		
44	If not:	All Equipment Checks have been interrogated. Go to 00-030.		
45	Is Noise (byte 1, bit 0) on?	Go to 5A-000 for Models 3, 5, or 7. Go to 5B-000 for Models 4, 6, or 8.		
46	If not:	Go to Seq 43.		
47	Is Velocity Change During Write (byte 9, bit 1) on?	This is a tape motion problem. Go to 6A-000 for Models 3, 5, or 7. Go to 6B-000 for Models 4, 6, or 8.		

3803-2/3420

<b>XB0700</b> Seq 1 of 2	<b>2735750</b> Part Number	<b>See EC History</b>	<b>845958</b> 1 Sep 79	<b>847298</b> 15 Aug 83			
-----------------------------	-------------------------------	-----------------------	---------------------------	----------------------------	--	--	--

**00-040**

**SINGLE TAPE UNIT PROBLEMS (Cont'd)**

**00-041**

Seq	Condition/Instruction			Action
48	Are any of the following bits on?			This is a data flow problem in the tape unit. Go to 5A-000 for Models 3, 5, or 7. Go to 5B-000 for Models 4, 6, or 8. Refer to the description of the sense information on 00-005.
	<b>Description</b>	<b>Byte</b>	<b>Bit</b>	
	WTM Check	5	2	
	IBG Detected	8	0	
	SAGC Check	8	4	
	R/W VRC	3	0	
	MTE/LRC	3	1	
	Skew	3	2	
	End Data Check/CRC	3	3	
	VRC/ENV Check	3	4	
	Write Current Fail	6	1	
	Erase Head Fail	7	5	
	Start Read Check	5	4	
	Early Begin Read Back Check	8	3	
Slow Begin Read Back Check	8	5		
Slow End Read Back Check	8	6		

Seq	Condition/Instruction	Action						
49	Do you have any of the following bits on?  <table border="0"> <tr> <td><b>Description</b></td> <td><b>Byte, Bit</b></td> </tr> <tr> <td>Write Trigger VRC</td> <td>4, 3</td> </tr> <tr> <td>C or P Compare</td> <td>3, 7</td> </tr> </table>	<b>Description</b>	<b>Byte, Bit</b>	Write Trigger VRC	4, 3	C or P Compare	3, 7	This probably is not a single tape unit failure. Recheck symptoms and sense information on 00-005.
<b>Description</b>	<b>Byte, Bit</b>							
Write Trigger VRC	4, 3							
C or P Compare	3, 7							
50	If not:	All Data Checks have been interrogated. Recheck symptoms and Sense information on 00-005.						
51	Is Tape Unit Status B (byte 1, bit 2) on?	Go to 2A-000 for Models 3, 5, or 7. Go to 2B-000 for Models 4, 6, or 8.						
52	Is the Online/Offline switch set to the Offline position?	Set switch to Online and go to 00-030.						
53	Is the Enable/Disable switch at the tape control for the failing data path set to the Disable position?	Set switch to Enable and go to 00-030.						
54	Exchange signal cables with another tape unit to determine if the problem is in the tape unit.							
55	Does the problem stay with the original tape unit?	Change in order: 1. T-A1L6 2. T-A1L2 If not fixed, go to ALD FT910 and check the pick of the online relay.						
56	If not:	Check the signal cable to the failing tape unit for opens or shorts. If no trouble is found and entry was from 00-010, Seq 1A, return to 00-010, Seq 2. Otherwise, there is a communicator problem in the tape control. Go to 18-000 if there is 1x8 (selection logic). Go to 18-015 if this is a device switching problem.						

3803-2/3420

<b>XB0700</b> Seq 2 of 2	<b>2735750</b> Part Number	<b>See EC History</b>	<b>845958</b> 1 Sep 79	<b>847298</b> 15 Aug 83				
-----------------------------	-------------------------------	-----------------------	---------------------------	----------------------------	--	--	--	--

© Copyright International Business Machines Corporation 1976, 1979, 1983

**00-041**

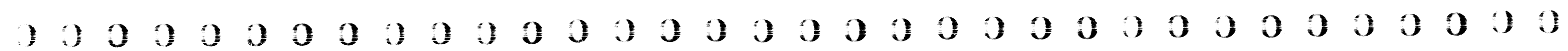

CONTENTS

This section contains information which fixed 3803/3420 problems in the field. The fixes listed have not been verified and are not eligible for suggestions. The data bank may contain other symptom/fix information not included here.

3803 Errors	
ALU Address Stops	00-050
B Bus	
Bus Out	
CE Panel	
Channel Interface	
Data Checks	
Device Ends	
Diagnostic Errors 3803/3420	00-051
Drive Access	
Equipment Checks	
File Protect	
"Hangs"	
Interface Control Check	00-052
Intervention Required	
Losing Tape Mark	
Microprogram Detected Error	
Mode Set	
Noise	00-053
Overrun	
Power Supply	
Program Halts, Abends, Messages	
Read	00-054
Reset	
Shifting Byte	
Tape "Runaway"	
Velocity	
Write Errors	
Write Tape Mark	

3420 Errors	
Adjustment	00-055
Backspace	
Bobble, Bottoms	
BOT/EOT	
Capstan	
Command Status Reject	
Drop/Pick Records	
Dropping Ready	
Equipment Checks	00-056
Erase Gap	
File Protect	
"Hangs"	
IBG	
Intervention Required	
Load Checks	
Meter	00-057
Not Capable	
Power Supply	00-058
Program	
Read Problems	
Reel Drive	
Reel Flanges	
Rewind	00-059
Tape Damage	
Tape Dump	
Tape "Runaway"	
Unload	00-060
Vacuum Columns	
Velocity Checks	
Power Window	
Write Errors	
Write Tape Mark	00-061
Tools and Test Equipment	

3803 Error		Symptom	FRU/Fix
ALU Address Stops			
ALU1	ALU2		
000	000		A2P3, B2K4.
7FF	7FF	"Hangs" after Rewind.	Power reset card J1/J2/B2C2.
301	000	Microprogram Check.	A2N2.
301		"Hangs" on Select to any tape unit.	B2E2/B3H2.
301	000	C Compare error.	A1S2.
301		"Hangs" on Select to any tape unit.	B2E2/B2C2.
302			
303			
301	000	NRZI read errors.	A2H2.
302			
303			
302		Cannot access tape unit.	B2C2.
3B0	000	D Bus parity error on reset.	A2T2.
3B0	000	High IC Microprogram Check.	A2H2/B2L2.
B Bus		B Bus parity errors.	A2P4.
Bus Out		Bus Out parity errors.	A-B2C2.
		Bus Out Check with parity bit bad.	Loose card at B2S2.
CE Panel		CE Panel ROS Step Mode multiple steps.	Reset/Start or Step switch.
		Cannot enter data from CE panel.	A1T2.
		Cannot access tape units from CE panel.	A1R2.
Channel Interface		Channel errors on other channel device.	A1B2 board connectors have a tendency to spread causing intermittent floating interface lines.
Data Check		Happens on a single tape unit.	A1L2 in tape unit.
		3803 Multi-Track or Envelope Checks. MTE and ENV Check with ripple on 6v.	6v Bus cable burned.
		MTE Check.	Clogged air filter.
		ENV Check with a 4v ripple.	Bad connection on power supply braided cables.
		MTE and ENV Checks with 6v ripple.	Bus cable from output of T1 to 6v supply.
		Temporary read or write errors.	MST card gate filter dirty.
Device Ends		Losing Device Ends.	-4v adjustment in 3420.
		Losing Device End with noise on voltage.	Meter card, part 0372688. RC network across RR1. See 3420 logic ZT001.
		Lost Device Ends.	01A-B2F2, 01A-A2K2.
		Lost Device Ends when the tape unit is made ready.	T-A1H2.
		Lost Device Ends on multiple tape units.	01A-A2R2.
		Lost Device Ends on all tape units.	T-A1L2.

3803-2/3420

XB0750	2736063	See EC	845958	847298				
Seq 1 of 2	Part Number	History	1 Sep 79	15 Aug 83				

3803 Error	Symptom	FRU/Fix
Diagnostic Errors 3803/3420*	See Table Following 3420 Section	
Drive Access	Cannot access tape units on Interface B or get CC3.	Without EC733814—B2S2. With EC733814—B2R2.
	Cannot access tape units.	Communicator cables not 48 pin (full pack).
	Select wrong device.	A2R2.
	Cannot access tape units offline.	A1R2.
	Cannot access tape units ALU2 at OCB.	A2D2.
	No Device End from tape units 4-7 after Rewind.	A2T2.
	Will not run offline.	A1R2.
	Cannot IPL from any tape unit.	01A-A2R2.
Equipment Check	When one tape unit of a subsystem gives Intervention Required (Not Ready) after a multi-reel tape operation, then that or any other tape unit accessed by the 3420 receives Equipment Check. (Take tape units physically offline, one at a time.)	T-A1J2 in one Model 3, 5, 7 tape unit.
	3803 would not perform any command and ends up in 301.	"Hot" bit 8 in tape unit address. A-A1R2.
	3420 Velocity error. One 3420 failed on T3420C, T3420G, T3420K, etc. <b>Example:</b> Received message AG213, AG214. Only one tape unit failed on OLTs.	A-A2E2.
File Protect	Sense byte indicates file protected, but lamp on tape unit is off.	Tape switch crosspoint card for failing tape unit.
	False file protect and bad sense data.	01A-A2K2, 01A-B2F2.
"Hang"	System "hang" or missing mounts on OS Release 19.0, 19.6, 20.0, or 20.1.	PTF 44800.
	CPU "hangs" in Test I/O loop or system loop on DOS 27.	APAR D00183.
	Channel Bus In Check on IPL.	Service grounds for Channel B on B2 board missing. See ALD ZV002 and ZV003.
	System "hangs" in wait state when using 4x16 configuration. "Hang" is result of continuous interrupts from 3420 with Unit Check alone in Status.	A-A2D2 or A-A2P4.
	Tape job "hangs". Test I/O from 2860 channels to each of four 3420s in a 4x16 configuration shows that on three control units, Busy is received and on the fourth control unit a Unit Check is received. Interrupt returns on the second Test I/O to that tape control.	A-A2P4.

3803 Error	Symptom	FRU/Fix																																																										
"Hang" (Cont'd)	DOS Program "hang".	If caused by Load Check on tape, add wire from H2U12 to H2U08 to disable Load Check. See ALD FT116.  If caused by mounting non-compatible or file protected tape, apply PTF 360N-453-0-0074 if Release 22, 23, 24, 25, 26 and PTO equal no.  If Release 22, 23, 24 and PTO equal yes, apply PTF 360N-453-0-006.  If Release 25 and PTO equal yes, you should not have a problem.  Releases earlier than 22 can get PTF and adapt it to their specific release.																																																										
		3803, 3420 with Two Channel Switch, MIS, "hangs" 2065 with 7080 Emulator. After giving a Rewind Unload, the system "hangs" with a contingent connection.  Patch Emulator program as follows: Address - 1630 Label - E10TATTN Verify 9180 0044 (Patch area) Replace with 47F0 F7AC (Branch to patch).  <table border="0"> <thead> <tr> <th>Address</th> <th>Enter</th> <th></th> </tr> </thead> <tbody> <tr><td>1DB0</td><td>9126</td><td>0044</td></tr> <tr><td>1DB4</td><td>4710</td><td>F7BC</td></tr> <tr><td>1DB8</td><td>9180</td><td>0044</td></tr> <tr><td>1DBC</td><td>47F0</td><td>F030</td></tr> <tr><td>1DC0</td><td>950F</td><td>1006</td></tr> <tr><td>1DC4</td><td>4770</td><td>F7B4</td></tr> <tr><td>1DC8</td><td>9500</td><td>100F</td></tr> <tr><td>1DCC</td><td>4770</td><td>F7B4</td></tr> <tr><td>1DD0</td><td>D20B</td><td>F7FC 0040</td></tr> <tr><td>1DD6</td><td>4130</td><td>F7F4</td></tr> <tr><td>1DDA</td><td>5030</td><td>0048</td></tr> <tr><td>1DDE</td><td>4840</td><td>1012</td></tr> <tr><td>1DE2</td><td>9C00</td><td>4000</td></tr> <tr><td>1DE6</td><td>D20B</td><td>0040 F7FC</td></tr> <tr><td>1DEC</td><td>9834</td><td>0198</td></tr> <tr><td>1DF0</td><td>47F0</td><td>F7B4</td></tr> <tr><td>1DF4</td><td>0700</td><td>0700</td></tr> <tr><td>1DF8</td><td>0401</td><td>EOC</td></tr> <tr><td>1DFC</td><td>2000</td><td>0006</td></tr> </tbody> </table> The addresses chosen for the patch are a blank area in storage; they can be anywhere in storage.	Address	Enter		1DB0	9126	0044	1DB4	4710	F7BC	1DB8	9180	0044	1DBC	47F0	F030	1DC0	950F	1006	1DC4	4770	F7B4	1DC8	9500	100F	1DCC	4770	F7B4	1DD0	D20B	F7FC 0040	1DD6	4130	F7F4	1DDA	5030	0048	1DDE	4840	1012	1DE2	9C00	4000	1DE6	D20B	0040 F7FC	1DEC	9834	0198	1DF0	47F0	F7B4	1DF4	0700	0700	1DF8	0401	EOC	1DFC
Address	Enter																																																											
1DB0	9126	0044																																																										
1DB4	4710	F7BC																																																										
1DB8	9180	0044																																																										
1DBC	47F0	F030																																																										
1DC0	950F	1006																																																										
1DC4	4770	F7B4																																																										
1DC8	9500	100F																																																										
1DCC	4770	F7B4																																																										
1DD0	D20B	F7FC 0040																																																										
1DD6	4130	F7F4																																																										
1DDA	5030	0048																																																										
1DDE	4840	1012																																																										
1DE2	9C00	4000																																																										
1DE6	D20B	0040 F7FC																																																										
1DEC	9834	0198																																																										
1DF0	47F0	F7B4																																																										
1DF4	0700	0700																																																										
1DF8	0401	EOC																																																										
1DFC	2000	0006																																																										

3803-2/3420

<b>XB0750</b> Seq 2 of 2	<b>2736063</b> Part Number	<b>See EC History</b>	<b>845958</b> 1 Sep 79	<b>847298</b> 15 Aug 83				
-----------------------------	-------------------------------	-----------------------	---------------------------	----------------------------	--	--	--	--

FIELD FEEDBACK (Cont'd)

00-052

3803 Error	Symptom	FRU/Fix
"Hang" (Cont'd)	DOS program "hang up". If tape subsystem configuration is 2x, 3x, or 4x, Device Switch and DOS use alternate path. A program loop between the two paths can occur with each indicating Device Busy.	APAR D15811.
	ASP program "hang" or wait with a 2x, 3x or 4x switch configuration and alternate path.	ASP APAR PA4886.
	Failure has occurred when tape configuration is 2x, 3x, or 4x with Two Channel switch and program uses alternate path. The program "hang" or wait usually occurs during an IPL and tape units are not Ready. Indications are Device Busy on one channel and an unexpected Device End Interrupt pending for the same device (ALU1 at 302) on the other channel. Error could also occur in a non-switching configuration as unexpected Device End interrupts.	A-A2D2.
	With Device Switch sometimes "hangs" or loops if one channel has Unit Check or Busy. Other channel cannot access tape unit.	DOS R260 APAR D17922.
	IPL in hard stop mode gets a CPU I/O System Check light and message "0T121" unrecoverable channel error.	A-A1R2.
	Two Channel Switch "hang" on both CPUs when a Rewind Unload command is issued to one tape on the first host of the 2x16.	Non-standard label routine contained a chained backspace record - NOP which backspaced over a tape mark and caused Unit Exception to break the chain.
	"Hangs" channel and fails T3420B with invalid Forward Space File.	A-B2C2.
	"Hang" with no response.	B2K4.
	"Hangs" channel Address Out, Select Out.	A1R2.
	"Hangs" system.	Loose 4v supply terminal connection. There are bolts with two nuts. One nut fastens the bolt to the printed circuit board and the second nut clamps the power cable to the bolt. The first nut in one case was not tight and the second nut was tight so the connection appeared tight, but was not and thus gave highly intermittent problems.
	3803 "hang" due to noise.	See 3420 ESD.
	"Hang" with Busy - DOS.	APAR D00183.
	"Hang" with ALU1 loop 0D4 - 0D8.	A2L2.
	"Hang" gives Unit Check only.	A2D2 of A2P4.
	"Hang" on Mode Set and also fails on open and close.	EC733834.
	"Hang" on IPL.	Tape switch logic card for subject tape unit.
"Hang" ALU1 at 3FF and ALU2 at 1FF.	A2P4.	

3803 Error	Symptom	FRU/Fix	
"Hang" (Cont'd)	Continuous interrupts.	A-A2D2 and A-A2E2.	
	"Hangs" after a mount message.	A-A2D2.	
	"Hangs" in a software loop.	A-B3H2.	
	System "hangs" with IFCC.	A-A2K2.	
	Multiple tape units "hang" busy on a 3x16.	A-A2D2.	
	Unexpected Interrupts.	T-A1L2.	
	Interface Control Check	DISCONNECT IN becoming active causes Interface Control Checks.	Jumper in 3420 was changed from 370 Mode to 360 Mode. See Installation Section.
		2x8 switch with two CPUs.	A-B3D2.
		IFCC and loops.	A-B2E2.
		In Tag Checks on a 3155/3168.	A-B2S2.
System "hangs".		A-A2K2.	
	With a NOP command.	A-A2D2.	
Intervention Required	3x16 configuration. System 2 and System 3 both work correctly with all 16 3420s. System 1 gives Intervention Required messages for tape units which to not require intervention.	A-A2E2 in 3420 for System 1.	
	Cannot disable the 3420 when the meter switch is turned off. Meter continues to run and customer can still access the tape unit.	A-A2R2.	
Losing Tape Mark	Losing tape mark on multiple data sets with 3x16 configuration. When the second control unit presented Device End and Channel End, the Command Chain (WTM, WTM, BSB, BSF, FSF) to the first control unit was broken before FSF. Therefore, the next Write command erased the tape marks.	Tape switch logic card.	
Microprogram Detected Error	Microprogram detected error - MTE and Envelope Check.	A-A2T2.	
	ALU1 microprogram error light.	01A-A2P4.	
Mode Set	3803/3420 failing to set NRZI.	A-A2M2 plugged wrong. See Installation Section.	

3803-2/3420

<b>XB0760</b> Seq 1 of 2	<b>2736064</b> Part Number	<b>See EC History</b>	<b>845958</b> 1 Sep 79					
-----------------------------	-------------------------------	-----------------------	---------------------------	--	--	--	--	--

00-052

3803 Error	Symptom	FRU/Fix
Noise	Noise caused by electrostatic discharge (ESD) may cause the ALU clock to stop. ALU High and/or Low IC errors, Bus Out Checks, and false 3420 Machine Resets. ESD is usually caused by environmental conditions such as low humidity or type of floor.	<ol style="list-style-type: none"> <li>1. Close and properly latch all covers. Make sure cable shield is installed on cable between 3803 and 3420.</li> <li>2. All covers must be closed and latched.</li> <li>3. Signal cable between 3803 and 3420 must be grounded at both ends.</li> <li>4. EC733819 ECA010 provides a rubber roller and brass frame door springs.</li> <li>5. EC733823 3803 ECA013 adds a hinge at green ground wire between right side cover and machine frame (serial numbers below 11117).</li> <li>6. EC733841 3803 ECA036 installs tie down jumper assembly 2520942 from A2H2S10 to A2H2S06 and from B2H2S10 to B2H2S06 to correct high and low IC errors.</li> <li>7. EC734281 3803 ECA042 prevents false machine resets due to a noise surge from the power-on-reset card in the +6v supply.</li> <li>8. EC733844 3803 ECA047 prevents system "hang" due to the ALU clocks being stopped and Bus Out Checks.</li> </ol>
Overrun	Overrun and 360 Model 50 Master Check with 3420.	Check ROS retry adjustment on the Model 50.
Power Supply	Cannot adjust the 4v supply.	<ol style="list-style-type: none"> <li>1. Neutral lead to transformer burned off but cover held the lead so tight that pulling on it did not show it to be loose.</li> <li>2. Poor connection from heat sink to Pin A of 4v regulator card. Add a jumper between heat sink and Pin A if unable to locate cause of high resistance.</li> </ol>
	Will not power up.	Wiring error. Wire from A3 TB1-6 to A2 TB1-6 was connected to heat sink on A2 instead of TB1-6.
	+6v output at +12v.	Input to the A2 supply on YF031 had transformer wires 10 and 11 shorted together.
	3803 powers up, powers down, ALU1 or ALU2 errors, "hangs", clock stops, tripped circuit breakers.	<ol style="list-style-type: none"> <li>1. Check all power supply components, capacitors, terminal boards, etc. for loose screws, cables shorting to frame, etc. Vibration may help.</li> <li>2. Check for defective capacitors, regulator cards, A1, A2, power boards.</li> <li>3. Shorted capacitors may cause circuit breakers to trip.</li> <li>4. Power drop can be caused by a vibration sensitive K4.</li> <li>5. Check voltage supply outputs for proper level. Be very critical of -4v supply.</li> <li>6. Make sure input voltage matches machine requirements.</li> <li>7. Check R2 through R7 leads soldered to power boards for tips shorted to land patterns.</li> </ol>

3803 Error	Symptom	FRU/Fix
Power Supply (Cont'd)	CB17 trips.	Wired for wrong line voltage. -4v supply.
	Cannot adjust -4v or -4v low and unregulated.	Remove -4v leads from TB1-6 and TB1-8. If -4v comes up to good level, when holding dc Reset switch, Power On Reset card in 6v supply (part 0375382) is defective.
	Trips CP19.	The ac relay board (part 2521483) has a defective diode or K7 relay coil shorted.
	4v missing.	Transformer in dc supply.
	CP17 trips.	-4v supply.
	Cannot adjust the 6v supply.	Defective 6v overcurrent card.
	CP14 trips on power up.	Defective capacitor at 01A-A2A2.
Program Halts, Abends, Messages	Abend 237, block count incorrect, drop records.	OS Release R207, APAR P60574.
	When writing new tapes, volume label is sometimes written, but HDR1 and HDR2 and tape mark are missing (OS Release 20.7).	APAR P44800.
	OS Abend 613, missing mounts or Device End problems.	These problems can be caused by not having the CPU UCW plugged properly.
	Getting Not Operational message on 3803 with Two Channel Switch which has one channel not used and terminated at CPU.	3803 was SYSGEN as Simulated Tape Adapter Unit because of previous 2804 on system. Message prints out for primary path but failure was on alternate path which was no longer there.
	Abend 237, block count error.	Two Channel switch generated in OS incorrectly and two channels were both accessing the same tape unit.
	After a tape is mounted and system tries to write the label message printed at console (I/O Error) and tape unloaded when using HASP.	A-B2M2.
	OS abends with 613, positional errors, when trying to Space File on a multi-reel file. Abend is a positional type error. Channel End is missing from status. Failed only if more than one job was running on tape.	<ol style="list-style-type: none"> <li>1. UCW for the 3420 in the 3155 was not plugged.</li> <li>2. Channel A - A-B2S2/R2.</li> <li>3. Channel B - B2R2 with Two Channel Switch feature.</li> <li>4. APAR 56478.</li> </ol>
	Block count errors, DOS 27.	APAR AD00186.
Lost bytes or garbled data from tapes.	A-B2L2, A-B2M2.	
False End of File, EOF/E0V.	Crosspoint card in tape switch.	

3803-2/3420

<b>XB0760</b> Seq 2 of 2	<b>2736064</b> Part Number	<b>See EC History</b>	<b>845958</b> 1 Sep 79				
-----------------------------	-------------------------------	-----------------------	---------------------------	--	--	--	--



FIELD FEEDBACK (Cont'd)

00-054

3803 Error	Symptom	FRU/Fix
Program Halts, Abends, Messages (Cont'd)	Rewind Unload problem.	Rewind Unload issued to multiple tape units at load point with MIS feature rewinds the first tape unit and the rest will not rewind either on or offline when using Model 50 Standalone 1410 Emulator program.  <b>Patch Emulator program</b> For 360-EU-728 S/A 1410/7010: 343C 47F0, 2760 3450 47F0, 2760 2760 9106, 0044 4710, 07C2 48E0, 003A 4510, 0EBE 47F0, 07C2 47F0, 2760  Following patch is for 360-EU-726 S/A 1410/7010 Emulator on 360 Model 50: 01230 477E, F720 3720 9106, 0044, 4710, 07CE, D20B, 0670, 0040 372E D203, 0048, EA44, 48A0, 003A 373B 9C00, A000, 472E, F738 3740 9D00, A000, 472E, F740 3748 D20B, 0040, 0670, 47F0, 07CE  This insures a Sense Op is issued after every Unit Check.
	Message OP19D, undetermined error.	01A-B2E2.
	Cannot access any tape units.	01A-B2Q2.
	Unexpected interrupts.	T-A1L2.
Read	Read incorrect data to CPU with no errors.	A2R2.
	Fails to read backwards.	01A-Y1H2.
Reset	Power On Reset 4FF, General Reset 377, ALU1.	Missing feature jumper on card at 01A B2D2. See A-A010 and A-A131.
	Power On Reset failing. ALU1 "hanging" at 0AC and 0A3 after power up.	Open wire between 01A A2K4B10 and J12 in 6v supply.
	Reset "hang".	Power On Reset card.
	No Power On Reset.	-4v supply.
Shifting Byte	Data on tape shifts one byte from one record to the next with no error indication.	Noise caused by other equipment manufacturer display unit.
Tape Runaway	Tape runaway on Write.	A2N2.
	All tape units runaway when writing.	01A-A2L2.
	Tape runaway when writing.	01A-Y1F2.
Velocity	False velocity change during Write.	A1S2.

3803 Error	Symptom	FRU/Fix
Write Errors	Creating bad tapes as if Backspace and Erase are not working properly.	OS R21.6 APARs P63263 and P60988.
	Write errors offline. Constant interrupts from all tape units that were READY. Device End and Busy on Initial Selection. Cannot write to tape unit offline. No error lights.	A2E2.
	Write errors.	A2E2.
	Loses first byte of data on a Write.	Defective A-B2L2.
Write Tape Mark	Missing tape marks when the tape is created. Address of the 3803 was not plugged in the UCW cards in 3155.	

3803-2/3420

<b>XB0770</b> Seq 1 of 2	<b>2736065</b> Part Number	<b>See EC History</b>	<b>845958</b> 1 Sep 79				
-----------------------------	-------------------------------	-----------------------	---------------------------	--	--	--	--

00-054

3420 Error	Symptom	FRU/Fix
Adjustment	Cannot make threshold adjustment.	1. R/W head skewed. 2. T-A1L2.
Backspace	Tape unit will not do consecutive backspace blocks.	Capstan motor.
	Backspace block failure.	T-A1F2 (Models 3, 5, and 7 only.)
Bobble, Bottoms	Tape bottoms in left column when forward, in right column when backward.	Power interface board regulator card (modified power supplies only).
	Bobble in either column.	1. K2-3 relay point. 2. CR1 (5214324) on reel motor control board.
	Tape bobbles in right column.	K1-7 on left reel board.
BOT/EOT	False BOT indication.	Rewind plunger stuck (Models 3, 5, and 7 only).
Capstan	Capstan squaring adjustment has limited range or appears to drift.	Replace fiber optic lamp.
Command Status Reject	Command Status Reject.	1. T-A1L6. 2. T-A1H2 (Models 3, 5, 7). 3. T-A1M6 (Models 4, 6, 8). 4. +6v power supply capacitors.
Drop or Pick Records	Record count incorrect.	1. Degauss tape cleaner blade. 2. Read amplifier card.
Dropping Ready	Caused by power supply.	1. Loose terminals on power interface board, fuse detect and EPO cards, power supply capacitors, and terminal boards. 2. Loose fitting fuse holders. May cause unloading in middle of job, power checks, equipment checks, or solenoid chattering. 3. Fuse detect card. Relay control card (90,000 series tape unit.) 4. -4v regulator card. 5. +6v regulator card. 6. Power interface board. 7. K1 contactor arcing. 8. Power interface board. 9. Loose fuse 3 on modified power supply.

3420 Error	Symptom	FRU/Fix
Dropping Ready (Cont'd)	Caused by vacuum.	1. Leaking right reel piston assembly. 2. Transfer valve leaking. 3. Vacuum switch failure. 4. Loose hoses to switches. 5. Defective air pressure regulator or reel hub pressure switch. 6. Faulty air bearing switch. 7. Pneumatic pump, hoses, belts, pulley. 8. Vacuum column manifold leaking. 9. Vacuum column door leaking. Some known causes are: a. Vacuum column door out of adjustment. See Section 08-000. b. Improperly installed air bearing. c. Reversed door glass. Lower left corner of door (viewed from vacuum side) should be sandblasted. If sandblast is on right side, glass is reversed.
	Miscellaneous	1. Capstan area. Adjust squaring pulses. Check solder connections on tach card and capstan board. 2. Reel Tach. Check for binding or dragging on foam rubber filler on top of vacuum column door. 3. Dirty EOT/BOT reflective sticker. 4. Select lamp partially shorted. 5. Noisy Online/Offline switch. 6. Left reel motor. 7. Manual status card. 8. MST A1B2. DROPS READY when going into high speed rewind. 9. MST A1G2. DROPS READY on start/stop writing from tester (Models 3, 5, 7 only). 10. Write driver. Fails on Start/Stop Write. 11. Cable rubbing on solenoid control relay. 12. Dirty air plenum filter. Gives momentary power check. 13. One side of 4.5v ac line to fiber optics lamp grounded. 14. Stubby bar loose.

3803-2/3420

<b>XB0770</b> Seq 2 of 2	<b>2736065</b> Part Number	<b>See EC History</b>	<b>845958</b> 1 Sep 79					
-----------------------------	-------------------------------	-----------------------	---------------------------	--	--	--	--	--





FIELD FEEDBACK (Cont'd)

00-056

3420 Error	Symptom	FRU/Fix
Dropping Ready (Cont'd)	Miscellaneous (Cont'd)	15. MST A1J2. DROPS READY during write operations. 16. Faulty ac input power to tape unit. Check all three phases. 17. Loose latch assembly at rear of right reel drive motor. If loose more than a few degrees, tighten or replace anti-rotation screw. 18. Cartridge open switch failed to make. 19. File Protect Relay defective. 20. T-A1M2. 21. T-A1D2.
Equipment Checks	Equipment Checks and Data Checks.	1. Dirty capstan surface. 2. High speed rewind solenoid leaking (Models 3, 5, 7 only). 3. BOT voltage. 4. Power supply interface board (may DROP READY also). 5. T-A1L2.
	Equipment Check on Mode Set.	1. T-A1H2 (Models 3, 5, 7). 2. T-A1M2 (Models 4, 6, 8).
	Equipment Checks reading header label.	1. T-A1H2 (Models 3, 5, 7). 2. T-A1M2 (Models 4, 6, 8).
	Equipment Check and velocity checks.	1. Fuse 2 holder. 2. A-A2E2 in 3420.
	Equipment Check on Write Tape Mark.	1. Capstan motor. 2. Amplifier Sensor adjustment (1600 bpi). 3. T-A1K4 (Models 3, 5, 7). 4. T-A1J2. 5. T-A1K6 (Models 4, 6, 8).
	Equipment check, erase head, write current.	File Protect switch.
	Tach start failure.	T-A1G2.
	Velocity errors.	Loose screws around the air plenum. Low vacuum in the stubby columns.
	Velocity change, MTE	Tape unit signal cables reversed.
	Early begin readback check.	Defective R/W head.
	Not operational.	T-A1L6.
	SAGC and ID Burst Checks.	Defective R/W head or degauss the head.
Erase head failure.	Cable to write head card pinched under a clamp.	

3420 Error	Symptom	FRU/Fix
Erase Gap	OS ERASE GAP—CONTINUE when customer uses tape. A block count error occurs.	1. Read amplifier card. 2. Degauss tape cleaner blade. 3. R/W head.
File Protect	File Protect message with ring installed.	PIN 360/S-DM-508-894 P44800-AB-ABEND-OCX.
	False File Protect indication.	T-A1L2.
	Solid File Protect failure.	Low air pressure. Tips of hoses were stretched.
"Hangs"	Tape will not move.	-4v regulator card.
	Intermittent missing mounts. Customer mounts tape and makes unit ready but nothing happens. When the unit is varied online, it runs.	-4v out of adjustment.
	System hangs in wait state. OS would not issue mount message nor rewind unload tape at end of job.	1. T-A1K4 (Models 3, 5, 7). 2. T-A1K6 (Models 4, 6, 8).
IBG	Short IBG.	1. T-A1F2 (Models 3, 5, 7). 2. Capstan motor. 3. Reference plate loose.
Intervention Required	Intervention Required with unit Ready, not File Protected, Unit Check, and Status A and B off.	1. T-A1G2 (Models 3, 5, 7). 2. Fuse detect card.
Load Checks	Tape hangs across top of columns, then suddenly loads by itself.	Belt slipping on vacuum pump.
	Tape dumps in right column during load.	Adjust vacuum column door.
	Tape loads in right column only.	Vented left column restrictor out of adjustment.
	Load Check after failing to wrap on left reel.	Temporary leader stuck on the end of tape was wrapped around left reel hub.
	Window goes up and down when loading.	Vacuum switch R4.
	Tape fails to go down lower restraint thread chute during load operation.	Cleaning lower restraint may cause static buildup on plastic. Wipe finger over lower restraint to discharge static.
	Load Check as tape goes into columns.	1. Vacuum switch R4. 2. Transfer valve.
	Fails to load tape into columns if file protect ring is removed.	Clogged filter from pneumatic pump.
	Transfer valve stays picked.	Shorted capacitor in RC network around K1 on SCRA card. RC network is P/N 1766179; capacitor is P/N 321412 (0.25 mfd 600 v). If RC network is temporarily disconnected, customer can run but may get false Load Checks.
	"Reels Loaded" not sense.	Place the hose from the pressure gauge over the reels loaded port and press LOAD. A reading of 21 is average. For a reading much lower than 21, look for air leaks. Check around the left reel tach mounting block for loose screws.

3803-2/3420

<b>XB0780</b> Seq 1 of 2	<b>2736066</b> Part Number	<b>See EC History</b>	<b>845958</b> 1 Sep 79				
-----------------------------	-------------------------------	-----------------------	---------------------------	--	--	--	--

00-056

3420 Error	Symptom	FRU/Fix
Load Checks (Cont'd)	Does not load tape into columns.	Air pressure system was restricted. (Clogged air filter, etc.)
	Tape unit loads, but READY light does not turn on for a few seconds.	Loose vacuum pump drive belt.
	Intermittently fails to load tape into left or right column.	Attach pressure gauge or manometer to the reel hub air pressure switch hose and load tape. Pressure should be about 70 inches. If pressure stops or goes up slowly, the reel hub is leaking. Air leak can be fixed by replacing the piston assembly on back of right reel motor.
	Tape threads correctly, but cartridge does not open.	T-A1E2 (Models 3, 5, 7). T-A1D4 (Models 4, 6, 8).
	Tape turns sideways in columns.	Transfer valve.
	Tape does not load into columns. Motion erratic.	R4.
	Loads wrong, motion erratic.	Dark light source bulb.
	Dumps tape in both columns.	Q8 on capstan board.
	Threads to left tach and stops.	Transfer valve.
	Low torque on left reel.	R4.
	Dumps tape in right column.	L3.
	Load failure, vacuum low.	Transfer valve.
	Tape unit would not load or unload.	Loose screws in power supply.
	Load Check, left reel fast.	Resistor shorted in fan housing.
	Load failure with no reel motion.	Check on reel board K1, N/C points.
	Load Checks and false Load Checks.	Power interface board.
	Tape flutter around left reel.	Resistor in fan housing.
	Tape will not thread onto left reel.	O-ring in left thread channel missing.
	Did not load tape into left column and dumped tape in right column.	Left float plate foam missing.
	Left reel does not turn.	MSC card, left reel board connector.
	Fails to return tape to load point after Load.	Transfer valve.
	Dumped tape in right column and transfer valve dropped.	Transfer valve relay.
	Failed to load in left column and would not unload.	Left reel board.
	Load failure with left reel fast.	Pluggable resistor on reel board.
	Reels do not turn on Load.	Fuse detect and EPO card.
	Loads, but tape does not go to load point.	Vacuum pump leak.
	Drops vacuum after Load.	Power interface board.
	Power Checks.	Cold solder joint at center lug of fuse 12.

3420 Error	Symptom	FRU/Fix	
Load Checks (Cont'd)	Failed to unload completely.	R1 Vacuum switch shorted.	
	Left reel turned counterclockwise at Load.	Fiber optics or light source dirty.	
	Load Checks, no Reels Loaded sensed.	Right reel motor board or MSC.	
	Equipment Checks, load problems, window problems, right reel turning wrong way, and tach start problems.	Fuse 5 and 15 ohms resistance.	
	Loads to BOT +2 and stops.	1. Filter was shorting to modified power supply board when transfer valve dropped out. 2. Right reel piston assembly leaking.	
	Tape dumps in right column or does not load into right column.	R1 Vacuum switch. Trouble may be caused by a sensitive switch that looks good in slow operation.	
	Load failure - pulls tape out of left column.	Loose pin on left reel paddle card.	
	Load Check - does not load into columns.	1. Left reel tach mounting screws loose. 2. Air pressure leak in supply manifold. 3. Clogged air filter or bad belt.	
	Unloads on a Load Rewind.	Tighten screws on power supply capacitors.	
	Load Checks on less than 2400 foot reel.	Check vacuum. Bad transfer valve or other leak in vacuum system.	
	Load Checks before BOT sense.	Pneumatic filter bad.	
	Load or motion control problems.	After installing B/M 1765523 (Models 3, 5, or 7) or replacing resistor cover assembly, problems arise. Heavy gauge wire is used on the resistors to the blower connector plug. When this assembly is installed, the male pins may back out causing poor or intermittent contact.	
	Load Checks after BOT sense.	Radius sense photocell wires rubbing on reel.	
	Will not rewind to load point on load.	L4 or R4 Vacuum switch.	
	Load Checks with mini reel only.	Replace radius sense reflective sticker.	
	Intermittent Load Check.	L3 Vacuum switch.	
	Will not load, pneumatic motor does not run.	Cartridge control SMS card.	
	Reels will not run, Power On Reset up solid.	CR11 on T2 (YF035).	
	Right reel turns at high speed during load.	Manual status card.	
	Loads into columns correctly, then pulls out of left column.	T-A1B2.	
	Left reel turns too fast.	T-A1L2.	
	Load Rewind fails.	Pressure pump input filter clogged.	
	Load failure, no Load Check.	L3 (transferring too quickly).	
	Tape fails to wrap around the left reel.	Transfer valve leaking.	
	Meter	Meter stops or reads low.	Jumper between T7 and T8 on meter card loose.
	Not Capable	Failing to read PE burst.	Read pre-amp card.

3803-2/3420

<b>XB0780</b> Seq 2 of 2	<b>2736066</b> Part Number	<b>See EC History</b>	<b>845958</b> 1 Sep 79					
-----------------------------	-------------------------------	-----------------------	---------------------------	--	--	--	--	--



FIELD FEEDBACK (Cont'd)

00-058

3420 Error	Symptom	FRU/Fix
Power Supply	Power Checks during a load operation.	Bad connector to power resistor panel.
	-4v low.	Loose screws on transistors on power interface board.
	Blows R67 on fuse detect card.	J6 cable shorted to frame.
	Load Check light flashes.	Loose fuse 3 or F3 holder.
	Power Check, Air Flow bit on, and Command Status Reject.	Loose capacitor screws, slip on connector to power interface board.
	Power Check light glows dim.	-4v return screws loose.
	Power Check light flashes.	Phasing bad, TB1-1/2/3 loose or bad air flow sensor.
	Blows OV/UV card.	HS-1 transistor on power interface board.
	Power Check, Load Check lights flicker. K1 relay on reel board points burn, 48v supply drops.	Loose wire from C8 to HS1 on mounting block for CR11, 12 or loose TB1-6/7.
	No output +12v, -12v, 4v or 6v.	Shorted capacitor C11 on transformer.
	Power Check when tape unit is selected.	Loose wire on power interface board.
	Rewind Unload in middle of job.	Short from MSC card to cover.
	Power Checks.	Tighten loose wire on 48v supply heat sink.
	6v high or has ripple.	Bad power interface board.
	Fails to write, dumps tape.	Bad 6v supply or bad connection to fuses on modified supply.
	Fails on Write.	Bad power interface board or loose ground braid on write card.
	Equipment Check and Unload in middle of job. Has ripple on supplies.	Loose fuses on modified supply.
	Blows fuse 6 and capacitor 1.	Bad SCR card, SCR1, SCR2.
	Select light after Load.	Flat cable from J1 on reel board pinched and shorting between frame and power interface board.
	Equipment Check, Power Check light on dim.	Bad voltage monitor card.
	Blows CB12 and 13 on power interface board.	J7 plugged one position off.
	6v varies or blows regulator card.	Bad connection J7-7 to J7-8.
	Blows fuse 3 on modified supply.	Bad write driver card.
	Blows fuse 10 or 12.	Loose screws on TB5-1.
	Blows fuse 6.	MSC card shorted to support bar or reel Power Control Board grounded to lower frame.
	Blows CP1.	SCR card.
	Blows fuse 14.	Shorted write head card.
	Blows write driver card and F14.	Read/Write cable plugged one pin off.
	Power Checks.	Bad solder connections at fuses.
	Power Checks.	Bad connection on J7 socket. (Power Interface Board.)

3420 Error	Symptom	FRU/Fix
Power Supply (Cont'd)	Power Checks.	Bad fuse detect and EPO card.
	Power Checks.	Bad CB1 or loose screws on circuit breaker.
	Power Checks.	Defective diode board in 4v supply.
	Power Checks.	Frame ground at -12 V. Erase head to frame.
	Power Checks.	Reed relay on OV/UV card.
	Blowing 6v regulator card and/or F1.	Power interface board.
	2v 20 Mhz noise on the power supply voltages.	Write head card.
	No -4v.	Power interface board.
	Blows fuse 5.	1. Shorted write card.
		2. Head inspection lamp contact bent and shorting to the frame.
Program	Running under OS, the operator gets message to mount tape. As soon as the tape is mounted, a message is given to dismount the tape. If the same tape is remounted, Data Checks may occur. Failure has occurred under OS 20.1 and OS 20.6.	Check that tape label is not password protected.
Read Problems	Tape records with low amplitude.	Degauss read/write head and tape cleaner block.
	Data Checks.	Tape deflector on erase head pushing tape away from head.
	Compatibility problems.	Capstan resistor in blower assembly.
	Compatibility problem.	T-A1L2.
	Unexpected Load point.	T-A1J2.
	Intermittent R/W failures.	Adjust vacuum column door.
Reel Drive	Blows reel control board.	1. Diodes 13 and 14 in 48v supply. 2. Power reset card.
	Loss of reel control.	MSC card.
	Left reel turns when powering up.	T-A1C2.
	Resistor R4 burns on reel board.	A1B2.
	Blows right reel board.	Replaced capstan motor was running too fast and apparently overdriving reel control board on high speed rewind.
	Right reel binds.	Replaced piston assembly.
	Burns out left reel board.	MSC card.
Reel Flanges	Broken or spread reel flanges.	1. Reel hub alignment. 2. Binding or old-style reel tachs (see ECA067). 3. Poor tracking. 4. Tape curvature. 5. Defective reel hubs.

3803-2/3420

<b>XB0790</b> Seq 1 of 2	<b>8492592</b> Part Number	<b>See EC History</b>	<b>845958</b> 1 Sep 79				
-----------------------------	-------------------------------	-----------------------	---------------------------	--	--	--	--

00-058

3420 Error	Symptom	FRU/Fix
Rewind	Speed varies during high speed rewind.	MSC card.
	Unloads after rewind only if file protect ring is in.	Write head card.
	Wide excursions in left column.	Radius sense wire rubs on reel.
	Pulls out of right column during high speed rewind.	L1 or L3 connection shorted to cover.
	Dumps tape, pulls out, erratic motion.	1. Dark light source bulb. 2. Capstan tachometer.
	Pulls out of right column when going from high to low speed.	Capstan squaring circuit.
	Snaps tape if reset during high speed rewind.	Capstan squaring circuit.
	Solid high speed rewind status and load problem.	Capstan bad.
	Fails to high speed rewind and pulls tape out of stubby columns.	Transfer valve.
	Does not go Ready after rewind.	Transfer valve.
	Drops vacuum on high speed rewind.	Power interface board.
	Power check at end of high speed rewind.	Power interface board.
	No high speed rewind or high speed rewind erratic.	Glazed or binding reel tachometers.
	No high speed rewind and during Unload left reel turns clockwise.	Left reel board relay.
	Dumps in right column or loss of reel control.	Resistor in fan housing.
	Stays in high speed rewind to load point.	Reposition ferrite core and voltage cable.
	Pulls tape out of left column and may drop READY.	Transfer valve.
	Stops in Rewind.	Air pressure switch.
	Damages tape on Rewind.	Reel motor board.
	Tape rewinds and unloads during job.	Loose fuse clip for F2. Power interface board. 4v supply capacitor leads loose.
	Reels turn wrong way during Rewind Unload.	Transfer valve pressure manifold cracked.
	Tape loop in threading channel on Rewind (Models 3, 5, 7).	Install ECA 025, EC734395.
	Drops from high speed rewind to low speed rewind at start of Rewind.	Dark light source. Clean lamp per procedure. If not, replace lamp.
	Wide excursions in left column in high speed rewind.	1. R3 vacuum switch. 2. A1A5 cable.
	Snaps tape in high speed rewind.	Hose pulled off L1 switch.
	Will not rewind completely.	Right reel piston assembly.
Breaks tape as tape unit switches from low to high speed on high speed rewind.	Replace transfer valve and 3-way valve assembly.	
Tape breaks in high speed rewind.	T-A1E2.	

3420 Error	Symptom	FRU/Fix
Rewind (Cont'd)	High speed rewind problem.	1. Cable at T-A1A5 loose. 2. Hose to R3 on wrong port. 3. Loose fiber optic tube at the capstan tach.
	Dumps tape in left column on high speed rewind.	Vacuum switch R3.
	Tape pulls out of right column in high speed rewind.	6v supply was at 6.6v.
	Rewind Unload fails.	A1J2.
Tape Damage (See also Rewind)	Machine was pulling tape between the reel and the tape on an Unload. Appeared as if reels were turning in opposite directions and stretching tape.	T-A1C2.
	Breaks tape.	Vacuum switch R1 or L1.
	Breaks tape on high speed rewind.	Vacuum switch R2.
	Uneven winding.	File reel positioning.
	Pleats across tape width.	Stubby bar clearance.
	Tape edge damage.	Z bars in stubby columns had loose screws.
	Tape damage on high speed rewind. (Models 3, 5, 7.)	Adjust inspection mirror.
	Tape Dump	Dumps tape in right column.
Dumps tape in right column and as tape moves past lower vacuum switch it blows fuse 10.		Capstan control board.
When in high speed and REWIND and RESET keys are operated, tape pulls out of right column and dumps in left column.		Capstan tach mirror dirty or capstan squaring circuit adjustment.
Dumps tape in either column.		1. MSC card relay. 2. Capstan motor.
Tape pulls out of column at end of high speed rewind.		Capstan squaring adjustment.
Dumps tape in right column.		Capstan motor sticking. Loose fuse 3 on the modified power interface board. R1 and R2 vacuum switch.
Dumps tape in either column.		Capstan motor.
Tape "Runaway"		Tape "runaway" after Load Rewind.
	Tape "runaway" on write.	A1F2. (Models 3, 5, 7.)

3803-2/3420

<b>XB0790</b> Seq 2 of 2	<b>8492592</b> Part Number	<b>See EC History</b>	<b>845958</b> 1 Sep 79					
-----------------------------	-------------------------------	-----------------------	---------------------------	--	--	--	--	--



FIELD FEEDBACK (Cont'd)

00-060

3420 Error	Symptom	FRU/Fix
Unload	Unloads on Load Rewind.	1. Power supply capacitor lead loose. 2. EOT/BOT.
	Rewind Unload without a command.	1. 4v supply capacitor leads loose. 2. Power interface board. 3. Fuses on modified supply.
	Failing to unload without cartridge.	EOT/BOT block.
	Reels turn wrong way during Rewind Unload.	Transfer valve pressure manifold cracked.
	Left reel fails to turn on unload.	Door glass not sealing at the bottom. Realign door.
	Wraps tape on left reel on unload.	Transfer valve.
	Vacuum drops too soon.	T-A1E2.
	Tape stops above R1.	Diode across K1 (pneumatic motor pick) open.
	Window will not go down.	1. Broken or defective diode CR1 across K1 in the solenoid control relay assembly. 2. Broken or defective diode CR14 across K1 (motor control relay). 3. EC734231 (ECA017) not installed puts an RC network around the transfer valve relay. 4. Shorted capacitor across the reel pressure switch. 5. Defective air bearing pressure switch. 6. Open diode across the write enable relay.
	Tape will not pull out of columns.	Right reel resistor (mounted in the cooling unit).
	Tape not completely unloaded.	Reel hub air pressure switch.
	Tape sideways on the right reel.	T-A1E2.
	Unloads during customer job.	A-B2K4.
Vacuum Columns	Beaded tape worn.	B/M 1848717 is available from Mechanicsburg to replace glass beading in vacuum columns.
Velocity Checks	Tape moves slowly (Models 3, 5, 7).	Capstan resistor on logic ZT051.
	Velocity change during write.	Tape unit interface cables not plugged light to dark.
	Velocity error.	1. Stubby bar clearance to capstan. 2. O-ring missing behind D-bearing. 3. Models 3, 5, 7 only - install EC734953 on tape unit.
	Velocity retry.	Replace capstan motor.
	Velocity check, tach start failure.	6v supply or EOT/BOT adjustment.
	Velocity change during write.	Align door over vacuum columns to correct bad seal.
	Velocity checks on Model 7 tape units using back-coated tape.	Raise air bearing pressure to 75 inches. Calibrate pneumatic gauge with a water manometer before adjusting air bearing pressure.

3420 Error	Symptom	FRU/Fix
Power Window	Delay in READY because window not closing.	Faulty window gear reduction box.
	Blew fuse	Bad power control board, motor, or relay.
	Failed to operate.	Broken wire at back of fuse holder.
	Failed to lower.	Window up switch shorted to power control board.
	Failed to operate.	Defective, binding, improperly seated motor.
	Bind.	Bad channel.
	Blows power control board relay.	Defective J8 connector in power supply, loose connection on door cable.
	Window raises and lowers.	Missing +6v on A1 board. May blow fuse.
	Fails to lower.	Hub pressure switch wires pinched under bracket.
	Fails to raise or lower, oscillates, raises after Unload, lowers in high speed rewind.	A1E2 - Models 3, 5, 7. A1D4 - Models 4, 6, 8.
Write Errors	Write aborts, write tape mark errors, velocity errors, read errors.	Make sure capstan, tape cleaner block, and read/write head are cleaned at least once per shift.
	High temporary write errors on PE only.	Read amp sensor adjustment is now 23%. Use attenuator card, P/N 5861455 for adjustment.
	Data Check and multi-track. <b>Note:</b> Develop tape to see if a partial record has been written in IBG.	Replace erase head or reverse wires to erase head. Bad write driver card.
	Data Checks.	Tape deflector on erase head pushing tape away from head. Bend deflector out of the way.
	Write current failure.	+6v missing to write driver. Bad write cable.
	Postamble Checks on Write.	Read card bad.
	Read/Write errors.	A1C2 Defective rewind plunger (Models 3, 5, 7). Defective autocleaner - Models 4, 6, 8.
	SAGC Checks.	Low column vacuum caused by faulty transfer valve.
	Start Read Checks.	Capstan control board.
	T3420R fails with write errors. (Models 3, 5, 7).	Write errors started after read card was replaced for another problem. New card was at high EC level which required new attenuator card to adjust amp sensors. Adjust with proper attenuator card and procedure. New read card is EC734470, P/N 2522936. New threshold card that should be used is P/N 5861455.
Write card goes bad.	Defective R/W head.	
SAGC and ID burst checks.	Degauss or replace the R/W head.	
Intermittent R/W errors.	Adjust vacuum column door.	

3803-2/3420

XB0795 Seq 1 of 2	8492593 Part Number	See EC History	845958 1 Sep 79				
----------------------	------------------------	-------------------	--------------------	--	--	--	--

00-060

FIELD FEEDBACK (Cont'd)

00-061

3420 Error	Symptom	FRU/Fix
Write Tape Mark	Equipment checks on Write Tape Mark.	Amp sensor adjustment off.
	Erase Gap, Write Tape Mark error.	T-A1K4 - Models 3, 5, 7 T-A1K6 - Models 4, 6, 8 T-A1J2.
	No block detected on Write Tape Mark and intermittent Velocity Checks.	Belt was on wrong pulley on vacuum pump.
	Slow end readback.	Read head card.
Tools and Test Equipment	Field tester causes channel errors.	T-A1L6.
	Model 7 writing .3 inch gaps with field tester.	Normal operation.

*Diagnostic Errors 3803/3420	Messages	FRU/Fix
T3420A	Command status reject.	T-A1K4.
T3420C	Start read check.	Capstan motor board.
	Velocity retry error.	Capstan motor. T-A1E2.
	MSG AC0101, AC0102, AC0203.	A-A1C2.
	"Hangs", interface control checks.	A-B2C2.
T3420E	MSG AE0831, AE0931.	A-A1S2.
T3420F	MSG AF0501.	A-A1C2.
	Not Capable.	A-A1C2.
	R/W, VRC, ENV, SKEW errors.	Erase head.
T3420G	Velocity retry error.	Capstan motor and T-A1E2.
	R/W, VRC, ENV, SKEW errors.	Erase head.
T3420H	R/W, VRC, ENV, SKEW errors.	Erase head.
T3420I	MSG AI0108.	A-A2H2 down level.
T3420P	Noise, MSG AP204.	T-A1K2.
T3420R	MTE, End data checks, VRC.	Fiber optic lamp.
T3420S	MSG AS0105, wait code 10, unexpected interrupts.	T-A1K2.
	MSG AS0105, R/W, VRC.	Tachometer cover is rubbing on the capstan.
	MSG AS010, Not Capable.	Binding high speed rewind plunger.
	Fails on a FWD Space Block command.	A-A2E2.
	Tachometer errors.	Open C4 capacitor.
	Excessive postamble.	A-A1D2.
T3420U	Velocity retry errors.	Capstan motor and T-A1E2.
T3420V	MSG AV0102.	A-B2C2.
	MSG AV0105, lost records.	T-A1G2.
	Start read check.	Hose at the pressure pump is split.
	No tape stop within 65 tach pulses.	A-B2D2.
T3420W	Short gaps.	Adjust vacuum column door.

3803-2/3420

XB0795 Seq 2 of 2	8492593 Part Number	See EC History	845958 1 Sep 79						
----------------------	------------------------	-------------------	--------------------	--	--	--	--	--	--

00-061

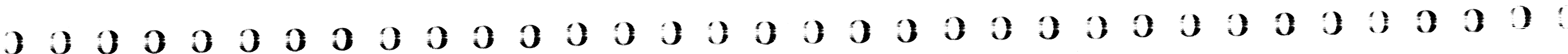

**3420 Power Supplies**

Each tape unit has a self-contained power supply, and receives its input power from the tape control. A three-phase, 15-amp circuit breaker protects the line voltage to each tape unit.

A 60-Hz machine requires 200, 208, or 230 volts; while 50-Hz machines use 200, 220, 235, 380, or 408 volts.

**Caution:** There are two types of fuse holders in the field. The first type of fuse holder has the spring in the cap and the second type has the spring in the body. If the cap of the second type is placed on the body of the first type no spring tension will be on the fuse causing intermittent contact.

**IF THE CAP OF THE FIRST TYPE IS PLACED ON THE BODY OF THE SECOND TYPE A SAFETY HAZARD WILL EXIST DUE TO EXPOSED METAL WHICH WILL HAVE A POTENTIAL ON IT.**

**3420 AIRFLOW AND VOLTAGE MONITORING SYSTEM**

A mercury switch mounted on a movable air vane below the capstan control board (C) monitors the cooling system airflow. If sufficient air is moving through the plenum, the vane is moved and the switch closes. If the switch opens, or doesn't close, the tape unit activates the Power Check indicator lamp.

The same system monitors dc voltages (E). If any voltage becomes out of tolerance, the output of Loss of Air, or the Over Voltage/Under Voltage (OV/UV) detector will activate the Power Check indicator lamp. This output also activates the Air or OV/UV latch and sets sense byte 18, bit 0.

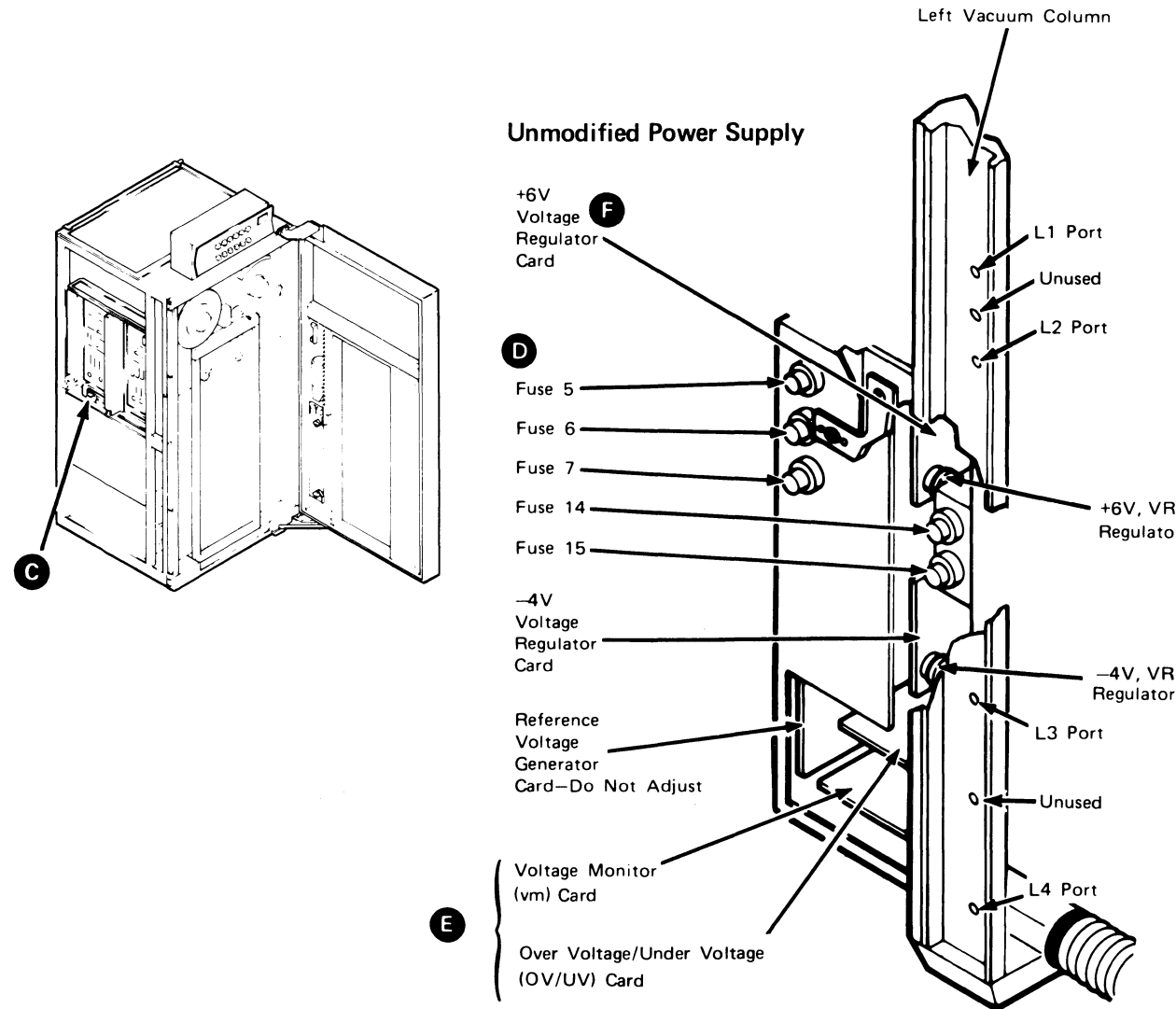
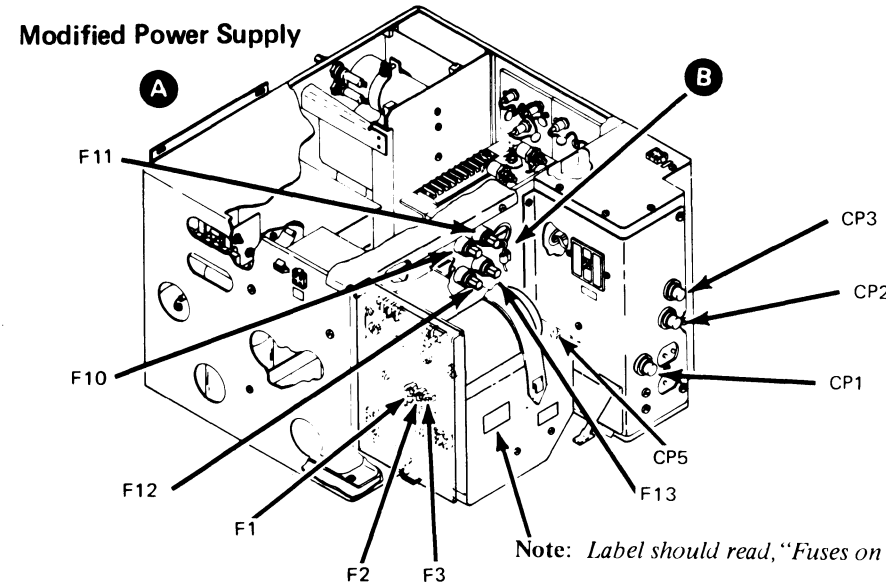

**FILE PROTECT INDICATOR OFF OR POWER CHECK INDICATOR ON**

From START 2		
<b>Notes:</b>		
1. The +6V is adjusted by measuring between G1E09 and B2D08 and adjusting the regulator for +6±0.05 Vdc with the Drive Ready in Write status and away from load point.		
2. If the 6 volt power supply is adjusted, the following check should be made: a. The drive must be loaded, Ready, and in Write status, and away from load point. b. Measure from G2B11 to G2D08 (ground). c. The reading must not exceed 6.24 volts. If it does, check the file protect circuitry for possible resistance.		
3. The -48 power supply voltage should be a minimum of -47 V with the machine loaded and ready with no tape motion. If the voltage is low, suspect the SCR's in the -48 V supply. Check the SCR's by removing the SCR control card. There should be a 4 V loss with the card removed.		
4. Following problem determination and repair, final power supply checks and/or adjustments should be made according to the directions included on MLM page 08-570.		
<b>Always start with Seq 1 and follow the procedure in sequence unless otherwise directed. Remember to END all problem or maintenance calls by going to MAP 00-030.</b>		
Seq	Condition/Instruction	Action
1	Does tape unit have a modified (piggy back power supply)? (A)	Go to Seq 35.
2	Check rear of unit. (B) Are F10, F11, F12, or F13 blown?	Go to Seq 18.
3	Check rear of unit. Are CP1, CP2, or CP3 (or CP4-50 hz only) tripped?	Check components using ALD pages YB020/5 & YB030/5. Go to 00-030.
4	Check front of unit. (D) Are F5, F6, F7, F14, or F15 blown?	Go to Seq 23.
4A	Check that all voltages are present. See Seq 11, 16, and 17A.	
5	Is File Protect indicator ON?	Go to Seq 7.
6	If not:	<ul style="list-style-type: none"> <li>Possible FRUs</li> <li>File Protect lamp or socket</li> <li>File Protect switch plunger</li> <li>File Protect switch</li> <li>Defective relay on write enable board (located below the right reel motor)</li> <li>T-A1H2</li> </ul> Go to ALD ZT071 for further analysis.
7	is the cooler blower operating?	Go to Seq 9.
8	If not:	Refer to ALD page YB030/5. Repair or replace as required. Go to 00-030.
9	Is there sufficient airflow at the logic gate? (Compare to another drive, if necessary.)	Go to Seq 11.
10	If not:	Check the air filter, hoses, ducts, blower motor fan, and motor direction.

3803-1,2,3/3420

<b>XB0800</b>	<b>2735751</b>	<b>See EC History</b>	<b>845958</b>	<b>846927</b>	<b>847298</b>			
Seq 1 of 2	Part Number		1 Sep 79	20 Jun 80	15 Aug 83			

© Copyright International Business Machines Corporation 1976, 1979, 1980, 1983

Seq	Condition/Instruction	Action
11	Use a *DIGITEC 201 or DIGITEC 251 for all voltage measurements. Is +6±0.3 Vdc present between -G2B11 and G2D08? (Do not adjust to this voltage).	Go to seq 14.
* Trademark of United Systems Corporation		
12	Can the +6 Volt regulator card be adjusted to + -+0.3 V? (This is not the final adjustment. See Note).	Go to Seq 14.
13	If not:	Replace the +6 V regulator card or interface board <b>F</b> . See Notes 1 and 2.
14	Is the Power Check indicator still On?	Go to Seq 16.
15	If not:	See Notes 1 and 2 on 1A-000.
16	Is -4.05±0.05 Vdc present between N3D02 and N3D08?	Go to Seq 17A.
17	If not:	Adjust or replace the -4 V regulator card or interface board.
17A	Are the following voltages out of tolerance? -48V: TB1-9 to TB1-8 +12V: +1.0, -1.0V TB2-1 to TB2-4 -12V: +1.0, -1.0V TB2-5 to TB2-7 +11V: +2, -1.2V TB3-12 to TB2-4	Replace the OV/UV card <b>E</b> on 1A-000 and the voltage monitor card. See NOTE 3 on 2A-000.
17B	Connect a jumper from TB2-3 to TB2-8. Did the Power Check indicator go off?	Remove the jumper. Probable causes are: • Mercury switch on air vane <b>C</b> on 1A-000). • Insufficient air flow. Repair as necessary.
17C	If not:	Remove jumper. Recheck symptoms.
18	Turn power off and replace the blown fuse. F10 4A medium blow (M3 & M5) 10A long blow (M7) F11 8A medium blow F12,13 10A medium blow (M3 & M5) 15A medium blow (M7)	Restore power and go to Seq 19. (See <b>B</b> on 1A-100).
19	Does the fuse blow again?	Replace the blown fuse and its corresponding FRU in the order listed. To verify the fix, restore power and operate tape unit. F10 1. Capstan motor control board 2. A1F2 (ALD FT39X) 3. A1G2 (ALD FT35X) 4. Capstan motor assembly 5. Power window circuit  F11 1. Left reel board 2. Right reel board

Seq	Condition/Instruction	Action
19	(Continued)	F121. Right reel board 2. A1B2 (ALD FT45X)  F131. Left reel board 2. A1B2 (ALD FT45X)  Go to Seq 21.
20	If not:	Go to ALD YB030/5. Repair or replace as required.
21	Is problem fixed?	Go to 00-030.
22	If not:	Replace the power supply MSC card (ALD YB030/5). Go to 00-030.
23	Turn power off and replace the blown fuse. Restore power and go to Seq 24.	
24	Does the fuse blow again?	Turn power off. Disconnect load to blown fuse at terminal board. Replace the blown fuse. F5 TB2-1; TB2-2 (gray wires) F6 TB2-5; TB2-6 (purple wires) F7 TB3-1 F14 TB3-3 F15 TB3-2 (dc ground is TB1-8) Restore power and go to Seq 26.
25	If not:	Refer to ALD YB030/5. Repair or replace as required.
26	Does the fuse blow again?	Go to Seq 29.
27	Turn power off. Measure from the removed wire(s) to ground and to other voltages for shorts. Repair as required. See ALD ZT031 for 4.5Vac and ALD ZT051 for dc voltages.	
28	Reconnect leads previously removed from the terminal board. Restore power and operate tape unit.	
29	Does F5, F6, or F7 blow?	Turn power off. There is a wiring problem in the power supply. See ALD YB020/5. Repair as required. Restore power. Go to 00-030.
30	Was F14 or F15 blown?	Turn power off. Remove regulator card associated with blown fuse. See fuse list in Seq 24 and ALD YB020/5. Replace fuse and restore power.
31	Does F14 or F15 blow again?	Turn power off. Check wiring from fuse to regulator card. Correct wiring problem and reinstall regulator cards previously removed. See ALD YB020/5. Restore power. If fixed, go to 00-030.
32	Install new regulator card and adjust the voltage.	
33	Does fuse blow again?	Turn power off. Replace the associated capacitor and fuse. Restore power and go to 00-030.
34	If not:	Go to 00-030.

Seq	Condition/Instruction	Action
35	This is a tape unit with a modified power supply.	
36	Check rear of unit. Is F10, F11, F12, or F13 blown?	Go to Seq 18.
37	Check rear of unit. If F1, F2, or F3 blown (located on the modified power supply)? These are nonindicating fuses. See 1A-000 for component locations.	Go to Seq 53.
38	Check rear of unit. Is CP1, CP2, CP3 (60 Hz), CP4 (50 Hz), or CP5 tripped?	Check components using ALD YB010/5 for CP1, CP2 (Models 3 and 5 only), and CP3 ALD YB020/5 for CP4; and ALD YB040/5 for CP5.
39	Check front of unit. Is F5, F6, F7, F8, or F9 blown?	Go to Seq 53.
39A	Check that all voltages are present. See Seq 46, 51, and 52A.	
40	Is File Protect indicator On?	Go to Seq 42.
41	If not:	Possible FRUs: • File Protect lamp or socket • File Protect switch plunger • File Protect switch • Defective relay on write enable board (located below right reel motor) • T-A1H2 Go to ALD ZT071 for further analysis.
42	Is the cooling blower operating?	Go to Seq 44.
43	If not:	Refer to ALD YB030/5. Repair or replace as required.
44	Is there sufficient airflow at the logic gate? (Compare to another drive, if necessary).	Go to Seq 46.
45	If not:	Check the air filter, hoses, ducts, blower motor fan blades, and motor direction.
46	Use a Digitec 201 or 251 for all voltage measurements. Is +6 ±0.3 Vdc present between G2B11 and G2D08? (Do not adjust to this voltage.)	Go to Seq 49.
47	Can the +6v regulator card be adjusted to +6 ±0.3 Vdc? (This is not the final adjustment).	Go to Seq 49.
48	If not:	Replace the +6 V regulator card or power interface board. See Notes 1 and 2 on (1A-000).
49	Is the Power Check indicator still On?	Go to Seq 51.
50	If not:	See Notes 1 and 2 on (1A-000).

3803-1,2,3/3420

XB0800 Seq 2 of 2	2735751 Part Number	See EC History	845958 1 Sep 79	846927 20 Jun 80	847298 15 Aug 83			
----------------------	------------------------	-------------------	--------------------	---------------------	---------------------	--	--	--

© Copyright International Business Machines Corporation 1976, 1979, 1980, 1983



Seq	Condition/Instruction	Action																																				
51	Is $-4.05 \pm 0.05$ Vdc present between N3D02 and N3D08?	Go to Seq 52A.																																				
52	If not:	Adjust or replace the $-4$ v regulator card or power interface board.																																				
52A	Are the following voltages out of tolerance? +30V: $\pm 0.5$ V TB2-3 to TB1-8 -48V: TB1-9 to TB1-8 +12V: +1.0, -1.0V TB3-1 to TB3-4 -12V: +1.0, -1.0V TB3-5 to TB3-4 +11V: +2, -1.2V TB2-1 to TB2-4	Replace OV/UV and the voltage monitor card. See Note 3 on 1A-000.																																				
52B	Connect a jumper from TB3-3 to TB3-8. Did the Power Check indicator go off?	Remove the jumper. Probable causes are: • Mercury switch located on the air vane. See <b>C</b> on 1A-000. • Insufficient air flow. Repair as necessary.																																				
52C	If not:	Recheck symptoms.																																				
53	From Seq 37. Turn power off. Replace the blown fuse. <table border="1"> <thead> <tr> <th>Fuse</th> <th>Rating</th> <th>Type</th> <th>Voltage</th> </tr> </thead> <tbody> <tr> <td>F1</td> <td>6A</td> <td>fast</td> <td>4.5 Vac</td> </tr> <tr> <td>F2</td> <td>15A</td> <td>med</td> <td>-4 V</td> </tr> <tr> <td>F3</td> <td>6A</td> <td>fast</td> <td>+6 V</td> </tr> <tr> <td>F5</td> <td>8A</td> <td>med</td> <td>+12 V</td> </tr> <tr> <td>F6</td> <td>15A</td> <td>med</td> <td>-12 V</td> </tr> <tr> <td>F7</td> <td>2A</td> <td>inst</td> <td>+11 V Reg</td> </tr> <tr> <td>F8</td> <td>2A</td> <td>inst</td> <td>-12 V*</td> </tr> <tr> <td>F9</td> <td>3/4A</td> <td>inst</td> <td>+30 V*</td> </tr> </tbody> </table> *for OV/UV sense See ALD YB040/5 for fuses F1—F3 and ALD YB020/5 for fuses F5—F9. Restore power and go to Seq 54.	Fuse	Rating	Type	Voltage	F1	6A	fast	4.5 Vac	F2	15A	med	-4 V	F3	6A	fast	+6 V	F5	8A	med	+12 V	F6	15A	med	-12 V	F7	2A	inst	+11 V Reg	F8	2A	inst	-12 V*	F9	3/4A	inst	+30 V*	
Fuse	Rating	Type	Voltage																																			
F1	6A	fast	4.5 Vac																																			
F2	15A	med	-4 V																																			
F3	6A	fast	+6 V																																			
F5	8A	med	+12 V																																			
F6	15A	med	-12 V																																			
F7	2A	inst	+11 V Reg																																			
F8	2A	inst	-12 V*																																			
F9	3/4A	inst	+30 V*																																			
54	Does the fuse blow again?	Turn power off and disconnect load to blown fuse at terminal board. Replace the blown fuse. F1 B1E3 See Figure on F2 B1E8 1A-003. F3 B1E10 F5 TB3-1, TB3-2 (gray wires) <b>A</b> F6 TB3-5, TB3-6 (purple wires) F7 TB2-1 (yellow wire) F8 TB2-2 (no external loads) F9 TB2-3 (no external loads) (dc ground is TB1-8) Restore power and go to Seq 56.																																				
55	If not:	Refer to ALD YB030/5. Repair or replace as required.																																				
56	Does the fuse blow again?	Go to Seq 59.																																				

Seq	Condition/Instruction	Action
57	Turn power off. Measure resistance from the wire disconnected in Seq 54 to ground and to other voltages for shorts. Repair as required. See ALD ZT031 for 4.5 Vac and ALD ZT051 for dc voltages.	
58	Reconnect wires disconnected in Seq 54. Restore power and operate tape unit.	Go to 00-030.
59	Does F1, F5, or F6 blow?	Turn power off. There is a wiring problem in the power supply. See ALD YB020/5 (F5 and F6) or YB040/5 (F1). Repair as required. Restore power and go to 00-030.
60	Are fuses F2 and F3 (see figure 1A-000) or F7, F8, or F9 blown? <b>B</b>	Turn power off. Remove regulator card associated with blown fuse. See fuse specification in Seq 53 and ALD YB040/5 (F2 and F3) or ALD YB020/5 (F7, F8, and F9). Replace fuse. Turn power on.
61	Does fuse blow again?	Turn power off. Check wiring from fuse to regulator card. Correct wiring problem, and reinstall regulator cards previously removed. See ALD YB020/5 and ALD YB040/5. Turn power on. If fixed, go to 00-030.
62	Install new regulator card and adjust the voltage.	
63	Does the fuse blow again?	Turn power off. Replace the associated capacitor and fuse. Turn power on. Go to 00-030.
64	If not:	Go to 00-030.

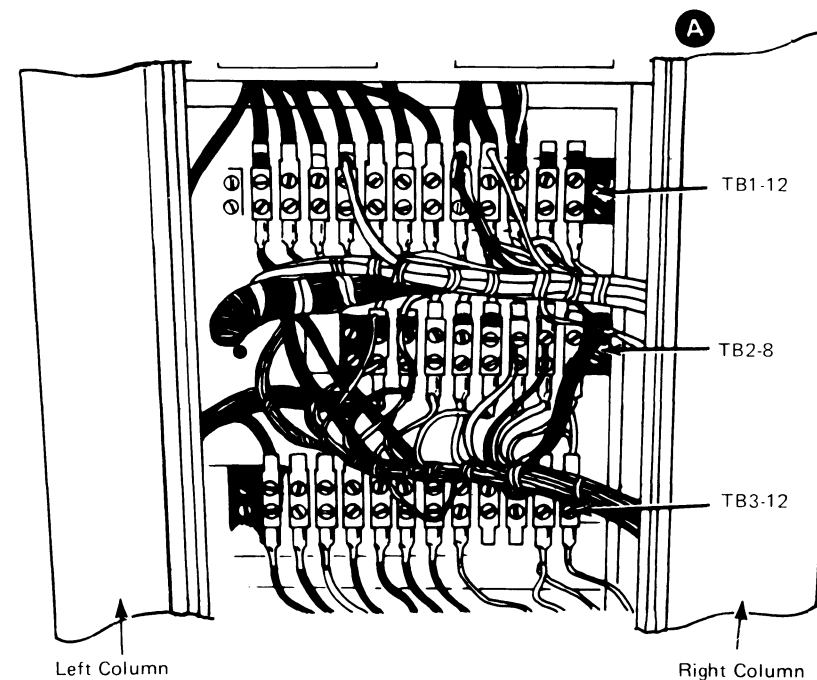

Modified Power Supply

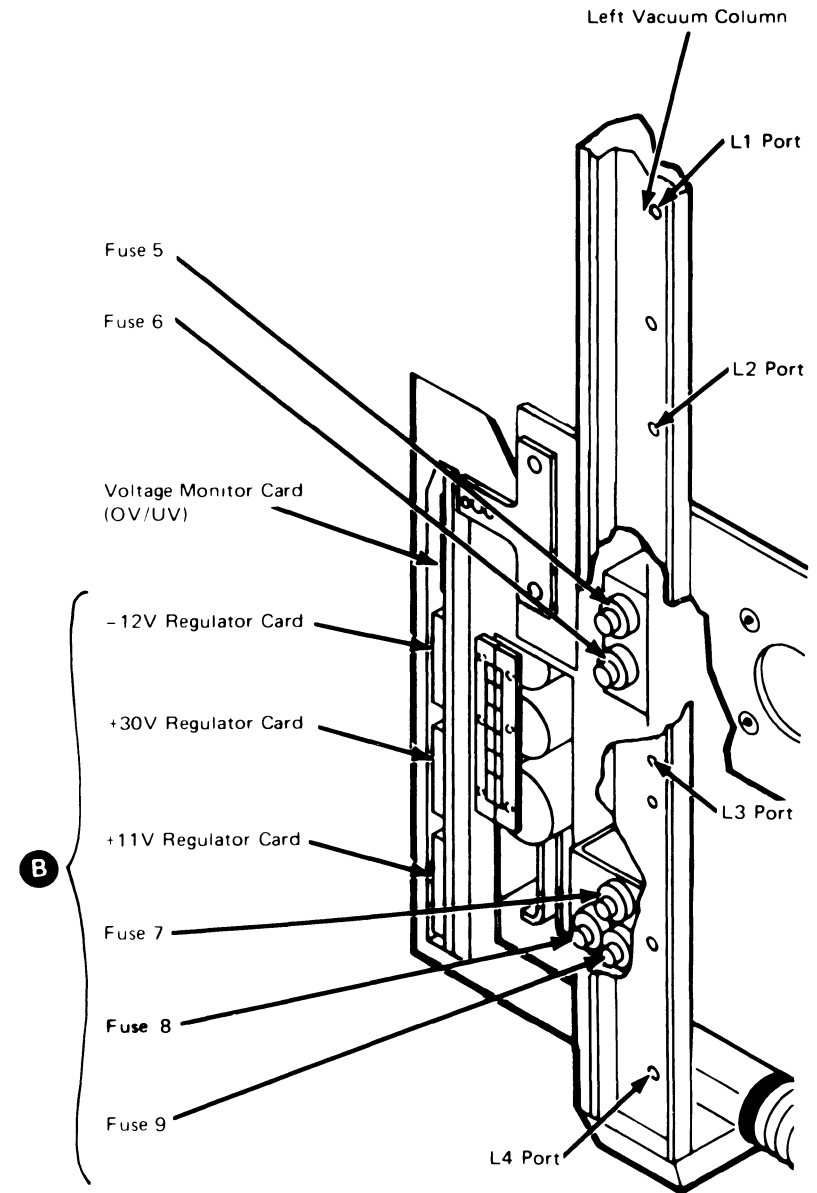

3803-1,2,3/3420

XB0900 Seq 1 of 2	2735752 Part Number	See EC History	845958 1 Sep 79	846927 20 Jun 80	847298 15 Aug 83		
----------------------	------------------------	-------------------	--------------------	---------------------	---------------------	--	--

Modified 3420 Power Interface Board, B1.

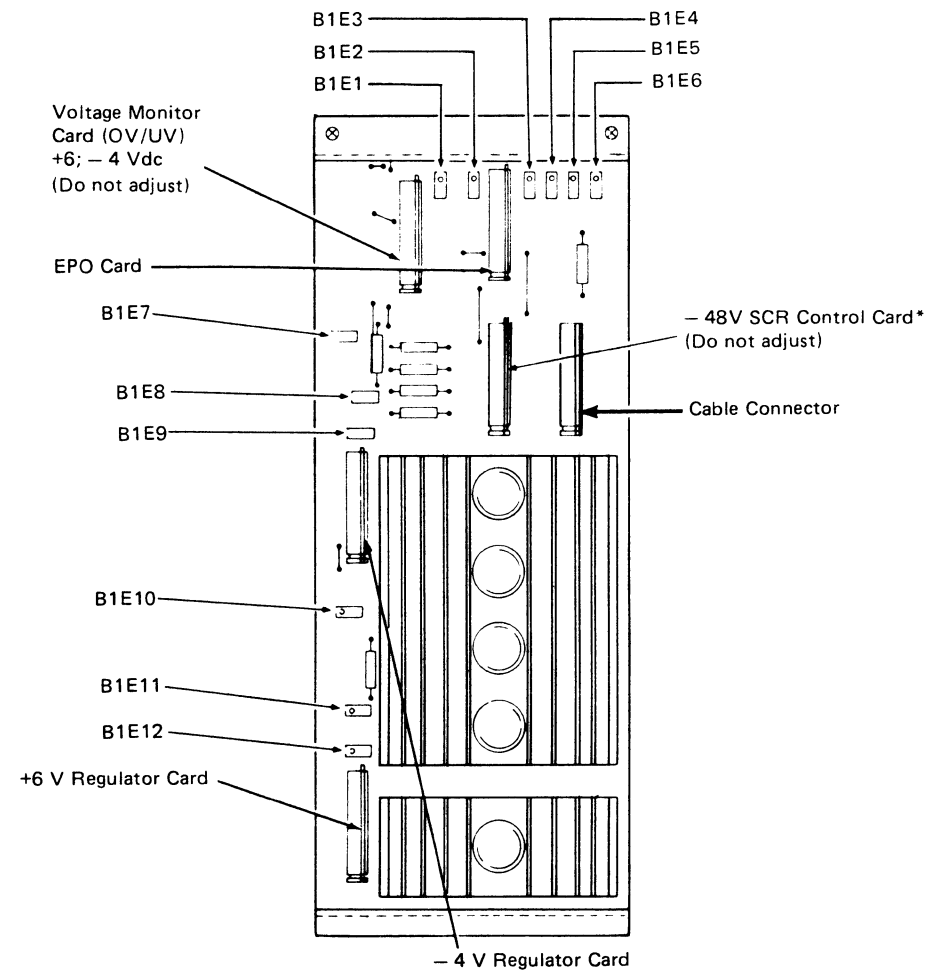

\*Not included in power supply part numbers:

- 1766046
- 2524645
- 2515421
- 2515413

3803-1,2,3/3420

<b>XB0900</b>	<b>2735752</b>	<b>See EC</b>	<b>845958</b>	<b>846927</b>	<b>847298</b>			
Seq 2 of 2	Part Number	History	1 Sep 79	20 Jun 80	15 Aug 83			

© Copyright International Business Machines Corporation 1976, 1979, 1980, 1983

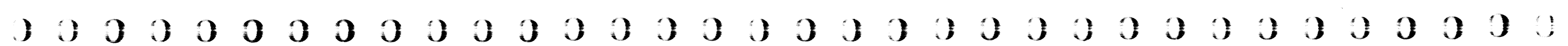

# DROPPING READY AND THREAD AND LOAD FAILURE SYMPTOMS

2A-000

From 00-040, START 2		
<b>Most Probable Cause:</b>		
<ul style="list-style-type: none"> <li>• T-A1C2, D2, E2, J2</li> <li>• Lamp</li> <li>• Capstan adjustment</li> <li>• L4, R4 vacuum switches</li> </ul>		
<b>Notes:</b>		
<ol style="list-style-type: none"> <li>The vacuum column vents (P/N 1846701) require special adjustment if both standard reels and minireels are used interchangeably on the drive. Refer to 08-800 for the adjustment procedure.</li> <li>Intermittent dropping ready and thread and load problems can be caused by:             <ol style="list-style-type: none"> <li>BOT/EOT out of adjustment. See 08-580.</li> <li>A loose pressure manifold on the 3-way valve (transfer valve assembly). The manifold is attached to the 3-way valve with four screws. Overtightening these screws can fracture or break off the mounting studs causing an air leak. See 08-000.</li> <li>A dirty pressure pump input filter.</li> <li>A leaking transfer valve. See 08-400 for leakage test.</li> <li>Vacuum column door leaking and/or not adjusted. See 08-680.</li> <li>A dirty pressure pump output filter.</li> <li>Damaged or aged vacuum column door foam. See 08-690.</li> </ol> </li> <li>If tape bottoms intermittently in either column, the capstan armature could be open. Unplug the capstan motor from the capstan board and measure across the two wires going to the motor with an ohmmeter. Watch for a deflection on the meter while rotating the capstan by hand very slowly.</li> <li>Threading with a cartridge may be a problem if the screw in the left end of the upper restraint is missing. Some upper restraints do not have a screw in this position.</li> </ol>		
<b>Always start with Seq 1 and follow the procedure in sequence unless directed otherwise. Remember to END all problem or maintenance calls by going to MAP 00-030.</b>		
Seq	Condition/Instruction	Action
1	Does problem exist only when using minireels?	Go to 08-800.
1A	With the tape unit unloaded, are the pneumatics on?	Go to 4A-160.
1B	Is the tape unit dropping READY?	Go to Seq 29.
2	Mount a reel of tape with a properly crimped and positioned end (see 2A-015) and with a properly placed BOT reflective marker. The field tester should not be plugged into the tape unit. Press the RESET, LOAD/REWIND buttons and then the START button.	
3	Was capstan turning continuously before load was attempted?	Go to 6A-000.
4	Is a cartridge being used?	If a cartridge doesn't open fully, go to 2A-100. Otherwise, proceed to the next Seq.
5	Does the left reel turn clockwise at threading speed? Compare with another drive.	Go to Seq 7.
6	If not:	Go to 2A-110.
7	Does the right reel turn clockwise at threading speed? Compare with another drive.	Go to Seq 9.
8	If not:	Go to 2A-120.

Seq	Condition/Instruction	Action
9	Does the tape thread past the read/write head?	Go to Seq 12.
10	Does the tape thread directly into the right vacuum column?	Go to 2A-130.
11	If not:	Go to 2A-140.
12	Does tape thread onto the left reel?	Go to Seq 14.
13	If not:	There is no vacuum on the left reel hub. Check transfer valve for proper sealing during thread status. Check vacuum and pneumatic belts. See Pneumatic Pressure/Vacuum checks and Pneumatic Supply Belt Replacement and Adjustment 08-400 and 08-440.
14	Does a Load Check occur before the BOT marker has passed BOT sense?	Go to 2A-150.
16	Does tape load into the columns properly?	Go to Seq 18.
17	If not:	Go to Seq 22.
18	Does the tape move backward properly until it stops at the BOT marker?	Go to Seq 24.
19	Does the tape go forward after loading into the columns?	Go to 2A-200.
20	Does tape bottom, bobble, or pull out of column?	Go to 2A-170.
21	If not:	Go to 2A-190.
22	Does the tape load into either vacuum column?	Go to 2A-170. See Note 1.
23	If not:	Go to 2A-160. See Note 1.
24	Is the window up and the Ready lamp on?	Go to 3A-000.
25	Does the Ready light turn ON?	Go to Seq 27.
26	If not:	Go to 2A-210.
27	Is the window down and the Ready lamp On?	Check window-up switch for a shorted condition.
28	Does Ready lamp fail to stay On?	Go to 3A-000.
29	Is the drop ready failure intermittent?	Go to Seq 31.
30	If not:	Approach as a load failure. Go to Seq 2.
31	Is Sense Byte 7 available?	Go to Chart A, column 3 on this page.
32	Is the drive still in the failing condition?	Scope logic pins as shown in Chart A, column 2 with the drive in the failing condition.
33	Is a visible symptom or customer description available?	Go to Chart A, column 1.
34	If not:	Go to 2A-005 (Drop Ready).

Chart A

1	2	3			
Error Description	Drive Error Condition	Error Sense	Probable Drive FRUs	Further Analysis	Notes
Fiber optic lamp failure, not latched	+ at H2S07	Byte 7 Bit 0	Optic lamp, A1D2	See Logic FT114	
Tape bottoms (see notes) or pulls out, left column	+ at H2U02	Byte 7 Bit 1	L4 vacuum switch, left reel board. (Check reel board EPO relay for shorted points). Capstan Tach.	Go to 3A-110	Could be caused by OV/UV detection or capstan board cooling sensor. See Byte 18, Bit 0 below.
Tape bottoms (see note 3) or pulls out, right column	+ at H2U05	Byte 7 Bit 2	R4 vacuum switch, right reel board. (Check reel board EPO relay for shorted points). Capstan Tach.	Go to 3A-110	Could be caused by OV/UV detection or capstan board cooling sensor. See Byte 18, Bit 0 below.
Reset key or door interlock	- at H2S08	Byte 7 Bit 3	Reset key, Door Interlock Switch, TA1C2, AB3F2, AA2D2.	See ALD FT114	Could be operator caused.
Air bearing pressure or right reel hub air failure	+ at H2S04	Byte 7 Bit 6	Leaking right reel hub. Air bearing or hub switch. Loose, worn or broken belt. Air system leak.	See ALD FT114	If a solid failure, tape will not dump into columns during a load operation.
OV/UV (Power Check) or no cooling air to capstan board	- at H2S02	Byte 18 Bit 0	Check voltages. Dirty filter, defective cooling fan. Check mercury switch below capstan board.	Go to 1A-000	These errors cause reel board EPO relays to drop resulting in loss of motor control. Tape bottom will then drop ready.
Power On Reset, not latched	+ at H2M05		A1C2, A1H2 Fuse detect card	See ALD FT112	Intermittent failures may show as a drop ready condition
Safety Bail Reset, not latched	+ at E2B09		A1C2, A1E2	See ALD FT283	Intermittent failures may show as a drop ready condition.

3803-1,2,3/3420

<b>XB1000</b> Seq 1 of 2	<b>2735753</b> Part Number	<b>See EC History</b>	<b>845958</b> 1 Sep 79	<b>846927</b> 20 Jun 80	<b>847298</b> 15 Aug 83		
-----------------------------	-------------------------------	-----------------------	---------------------------	----------------------------	----------------------------	--	--

2A-000

INTERMITTENT DROP READY PROBLEMS

Listed below are several causes of dropping Ready. Most probable cause is listed first. Examine the list and do any indicated action. If original failure still exists (Ready light off and tape still loaded and no sense Reset has been issued) bits for sense byte 7 can be scoped. See Chart A on 2A-000.

1. **Vacuum Switches:** Defective vacuum switches cause dropping Ready problems. If sense byte 7 is available, it can be helpful in determining which vacuum column is failing. Do procedure on 08-450 to check for failing vacuum switches.
2. **Fiber Optics:** Faulty or marginal fiber optics can cause tape loading problems, tape motion problems, and dropping Ready. Check the seating and clean the fiber optic bundles at the light source. Check the clearness of the lamp and replace it if questionable. (See 08-620).
3. **Capstan Squaring:** If capstan squaring is out of adjustment it will usually show up first by dropping Ready (pulls out of left column, or bottoms in the right column) when going into or coming out of a high speed rewind. See 08-130 for adjustment procedure. See 08-140 for cleaning procedure.
4. **Right Reel Slipping On Hub:**  
**Caution: Circuit damage or a blown fuse (F12) may result if the reel is held for more than five or six seconds.**

Slippage can be determined by loading a tape and turning the right reel until tape in the column is above, then below the ports causing the right reel to drive. Hold the reel to keep the tape and hub from turning and observe the amount of slippage. Compare with a known good tape unit. If excessive slippage is observed, go to 08-470 then 08-520 for checks and adjustments.

5. **Reel Tachs:** Defective reel tachs cause a tape unit to fail to enter high speed rewind and also cause dropping Ready while in high speed rewind. Check tachs for polished surfaces causing them to slip on the tape. If this condition is found, replace the reel tach assembly (see 08-550). Also check for binds in the bearings and tach wobble indicating worn bearings. Scope tach outputs (ALD FT231) for pulses of similar frequency, duration, and amplitude.
6. **Reel Motor Boards:** Either board causes intermittent problems. Check for cold flow solder joints, cracked land patterns, and loose or pushed pins in the connectors. If boards are suspect, interchange them with another tape unit to isolate the failure. (ALD RM001).
7. **Door Interlock:** Machine vibration can cause a badly adjusted Door Interlock switch to open intermittently. Also check main machine door latch alignment.
8. **Damaged Tape:** Stretched or spliced tape causes dropping Ready. If the failing tape has been retained make one complete pass, using the field tester.
9. **Power Supply:** Check for loose terminal connections and cold flow solder joints. Ask operator if power check light has been flashing. (Power check circuit is not latched).

3803-1,2,3/3420

<b>XB1000</b> Seq 2 of 2	<b>2735753</b> Part Number	<b>See EC</b> <b>History</b>	<b>845958</b> 1 Sep 79	<b>846927</b> 20 Jun 80	<b>847298</b> 15 Aug 83			
-----------------------------	-------------------------------	---------------------------------	---------------------------	----------------------------	----------------------------	--	--	--

© Copyright International Business Machines Corporation 1976, 1979, 1980, 1983



# THREAD AND LOAD OPERATIONS

The 3420 threads, loads, and unloads tape automatically with or without a tape cartridge. Air pressure automatically secures the reel of tape to the right reel hub. Any size reel of half-inch magnetic tape can be automatically loaded, but only full 10 1/2 inch (26,7 cm) reels can be loaded with a cartridge.

## THREAD LOAD WITH CARTRIDGE—TIMING CHART

A plunger on the tape unit senses that a cartridge is mounted on the right reel hub. Pressing the Load Rewind pushbutton (see timing chart line 2) activates the LOAD OP latch. (timing chart line 2). The Load Op latch:

- Activates Power Window Motor, which closes the window.
- Activates Thread Status, which energizes the transfer valve solenoid to switch vacuum and air pressure to the threading positions.
- Conditions the reel motors to turn in a clockwise (forward) direction (Section 3A-020).
- Activates Drive Cartridge Motor, which energizes the cartridge motor and causes the cartridge opener to rotate 200 degrees to a fully open position. When the cartridge is fully open, the cartridge open switch removes power from the cartridge motor.

With the cartridge open, the right reel starts feeding tape out the cartridge tape port and into the right threading channel. The left reel is already moving. The radius sense photocell drives the IBG (interblock gap) counter, which clocks the threading and loading sequences (see Section 6A-130). The IBG counter receives a pulse for each half turn of the left reel.

Tape moves through the threading channels and the head area guided by air pressure and vacuum ports. As tape leaves the left threading channel, vacuum at the left reel hub draws tape to the reel.

As tape is wrapped on the left reel, a slight tension forces the tape against the reels-loaded sensing port. Sealing this port causes a pressure change which signals the reels-loaded condition.

The reels continue turning forward until the beginning-of-tape (BOT) or load point (LP) marker is sensed at the BOT photocell. The BOT phototransistor fires the BOT singleshot which:

- Resets the IBG counter to zero
- Activates the Load/Rewind line
- Activates the Rewind Operation line
- Activates the Backward Status line

The IBG counter resumes counting from zero. At a count of 2, Thread Status is deactivated and the transfer valve solenoid is de-energized. Air pressure is now directed to the air bearings, and vacuum is switched to the vacuum columns, the capstan motor and the tape cleaner blade.

Air Bearing Pressure and Not Thread Status reverse the direction of the left reel motor.

As the left reel turns counterclockwise, the right reel continues to turn clockwise. The tape lowers into the vacuum columns until it is below port L2 in the left column and port R1 in the right column. With the tape in this position:

- Halt Right Reel Load is activated
- Halt Left Reel Load is activated
- Columns Loaded is activated which activates Load Complete and deactivates Manual Status.

With Manual Status Deactivated, normal column control becomes active. The capstan motor moves tape backward to the BOT marker.

Pressing the START switch activates Ready Status in the tape unit.

## Thread Load With Cartridge Timing Chart

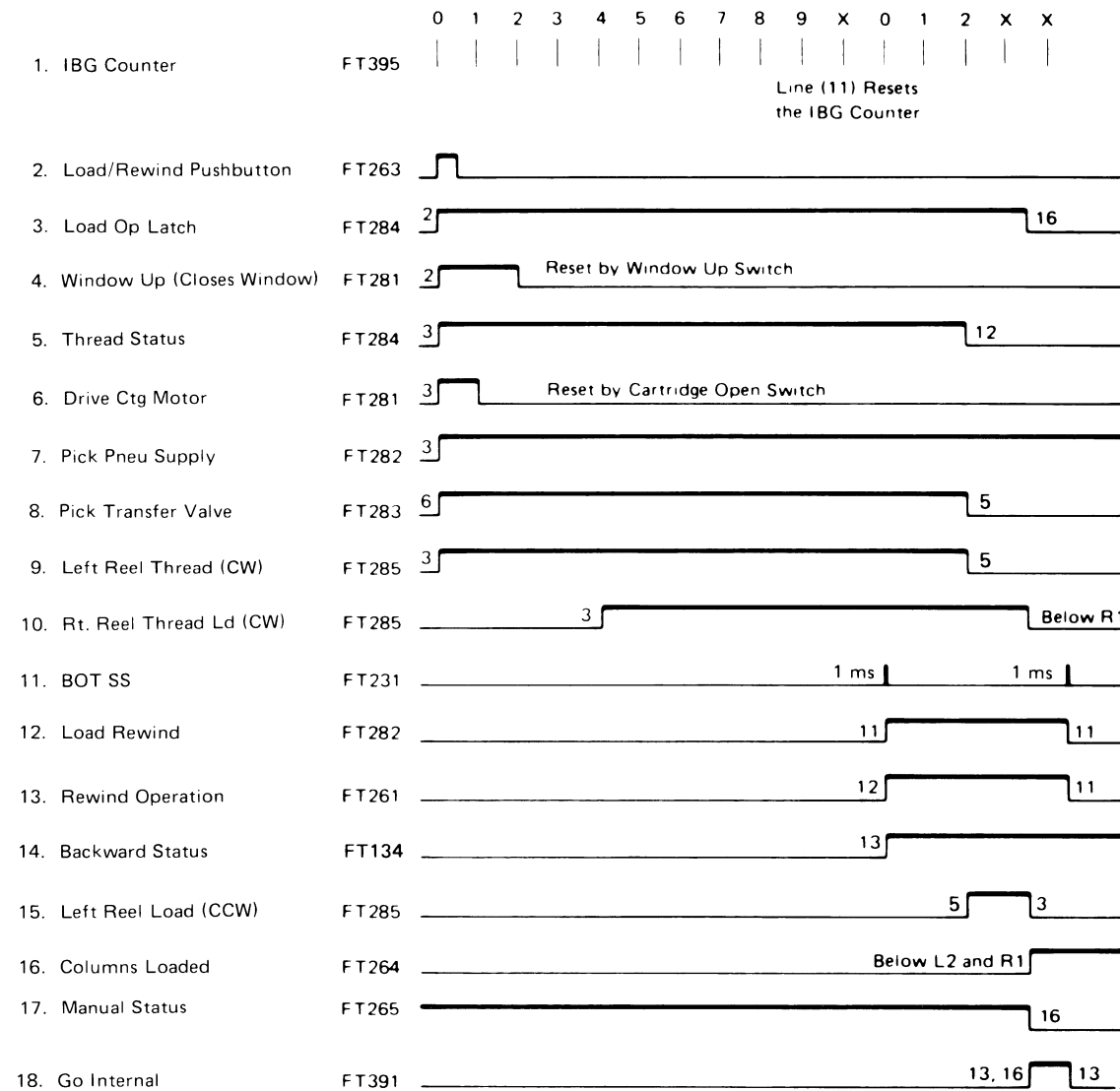

X = Number of IBG counts needed to reach the BOT marker.

3803-1,2,3/3420

XB1010 Seq 1 of 2	4169697 Part Number	See EC History	845958 1 Sep 79	846927 20 Jun 80				
----------------------	------------------------	-------------------	--------------------	---------------------	--	--	--	--

© Copyright International Business Machines Corporation 1976, 1979, 1980

# TAPE CRIMPER PROCEDURE

2A-015

Insert the tape with the oxide side towards the plunger and in a direction that will produce a rounded end when cut. See Figure below. Cutting tape with the oxide side away from the plunger can cause intermittent thread problems because the tape will have a tendency to curl the wrong direction.

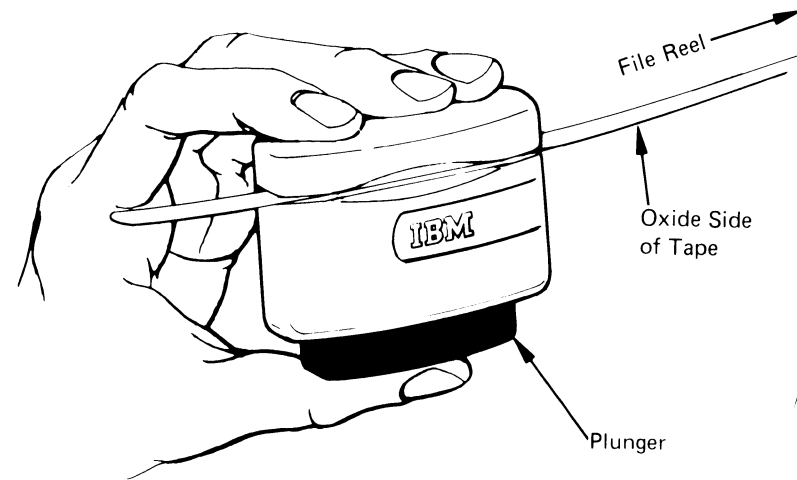

3803-1,2,3/3420

XB1010	4169697	See EC	845958	846927				
Seq 2 of 2	Part Number	History	1 Sep 79	20 Jun 80				

© Copyright International Business Machines Corporation 1976, 1979, 1980

2A-015



# THREAD LOAD CHECKING WITH CARTRIDGE—TIMING CHART

2A-020

The thread and load operations are checked at several points in the cycle. If the first attempt to thread and load fails, a second attempt is made. If the second attempt fails, a permanent load check error is set.

On the first attempt, tape must be sensed at BOT/EOT phototransistors before interblock gap (IBG) count 7. Failure to meet this condition usually results from the end of tape being in the wrong place in the cartridge or a damaged leader on the tape.

A second check is made at IBG count 12. At this point, the Reels Loaded switch must be transferred. If the tape doesn't wrap around the left hub, the switch can't be transferred.

A failure at either IBG count 7 or 12 causes the tape to be rewound on the file reel. The IBG counter continues to count as the left reel turns counterclockwise. At IBG count 20, the second attempt begins, and the Reels Loaded switch must be transferred before IBG count 28. If a failure occurs at IBG count 28, the tape rewinds on the file reel, and the thread and load operation aborts. The Load Check lamp remains on.

After a successful reels loaded sequence, the beginning-of-tape (BOT) marker must be detected before IBG count 44 (36 without EC 846437). If BOT isn't detected before IBG count 44 (36 without EC 846437), the operation stops (Tape isn't loaded into the columns or rewind on the file reel). An operator must determine if the BOT marker is in the correct place on the tape.

A final check is made four IBG counts after the BOT marker is detected. By this time, the Vacuum Present switch L4 must be transferred or the operation stops and the operator must intervene again.

If the BOT marker is not detected before IBG 44 (36 without EC 846437), or the Vacuum Column switch L4 is not transferred, no further attempts are made.

## THREAD LOAD WITHOUT CARTRIDGE (DIFFERENCES)

The cartridge opening motor is de-energized to prevent unnecessary motor travel during thread load without a cartridge.

## THREAD LOAD CHECKING WITHOUT CARTRIDGE (DIFFERENCES)

Without a cartridge, the first check is made at IBG 12 (9 without EC 846437). At this point, the Reels Loaded switch must be transferred or the operation stops and there is no further attempt.

If the thread and load operation is successful, the remaining checks are the same as with a cartridge.

## Thread Load Checking With Cartridge Timing Chart

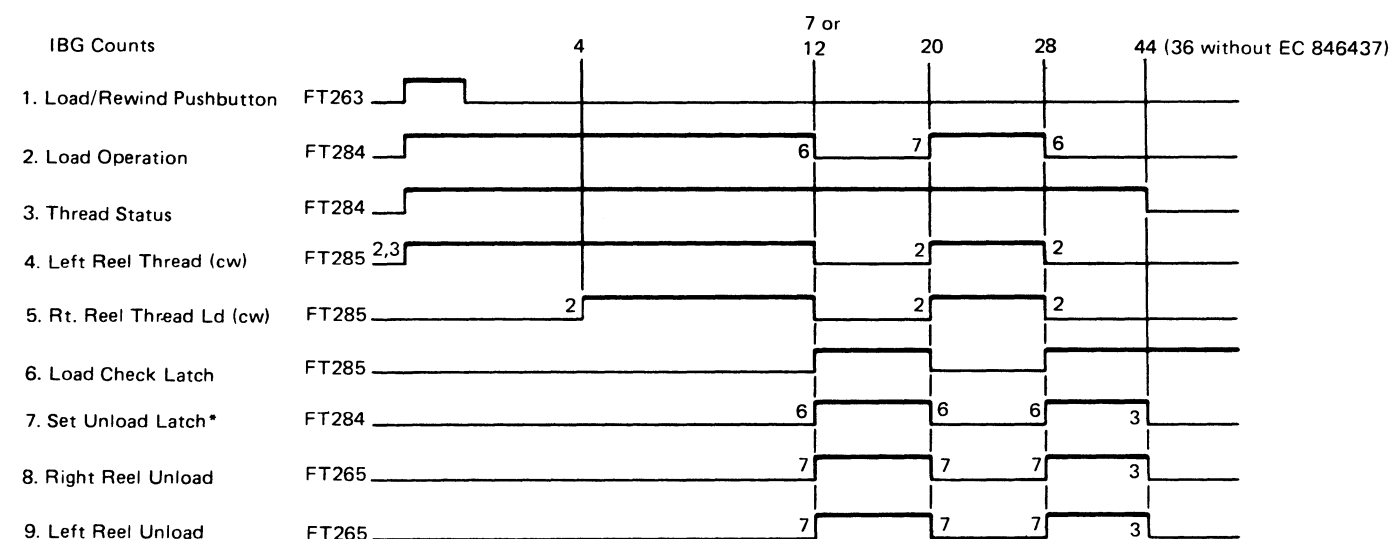

\*Unload Op (ALD FT265) is not set.

## THREAD LOAD CHECK POINTS

IBG Count	With Cartridge	Without Cartridge
7	tape present (BOT/EOT)	not used
9	not used	not used (reels loaded without EC 846437)
12	reels loaded	reels loaded (not used without EC 846437)
28	reels loaded (second try)	not used
44 (36 without EC 846437)	BOT detected	BOT detected
BOT +4	columns loaded	columns loaded

3803-1,2,3/3420

<b>XB1100</b> Seq 1 of 2	<b>2735754</b> Part Number	<b>See EC History</b>	<b>845958</b> 1 Sep 79	<b>846927</b> 20 Jun 80	<b>847298</b> 15 Aug 83		
-----------------------------	-------------------------------	-----------------------	---------------------------	----------------------------	----------------------------	--	--

© Copyright International Business Machines Corporation 1976, 1979, 1980, 1983

2A-020

# CARTRIDGE DOES NOT OPEN

Pressing The LOAD REWIND pushbutton sets Load Op and causes the cartridge motor to open the cartridge. The cartridge opener is rotated 200 degrees to a fully open position. The Cartridge Open switch then transfers and removes power from the cartridge motor. The Cartridge Open and Cartridge Closed switches are inside the cartridge opening mechanism.

Conditions that prevent setting Load Op and keep the cartridge motor from operating are:

1. The Door Interlock switch is open.
2. L4 or R4 vacuum switch is indicating a tape bottom condition.
3. RESET switch was pressed.
4. Safety Bail switch is tripped.
5. Any condition present that deactivates Mechanical Ready. Mechanical Ready is deactivated by Lamp Off, Tape Bottomed, or Air Pressure Failure.

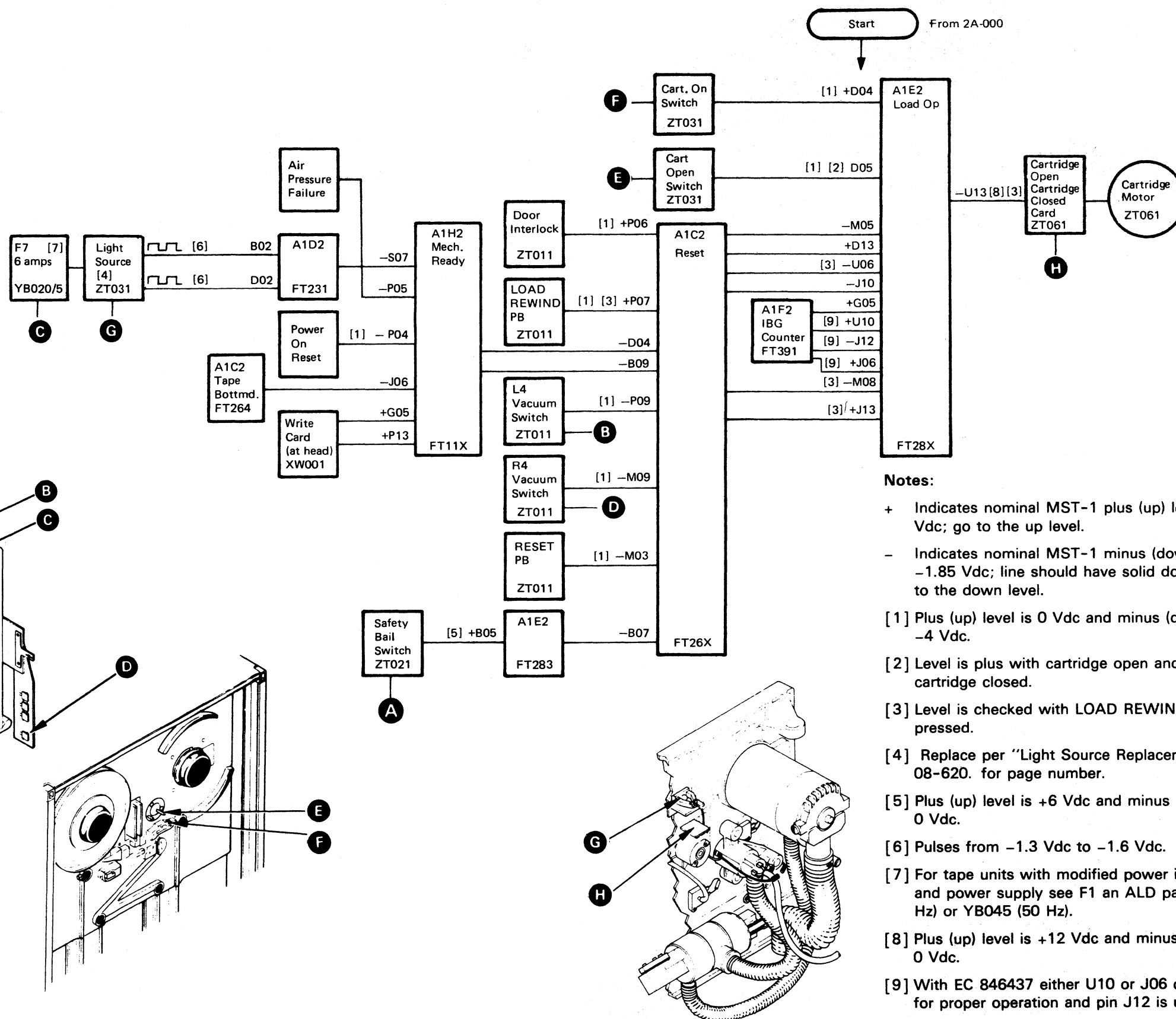

- Notes:**
- + Indicates nominal MST-1 plus (up) level of -0.85 Vdc; go to the up level.
  - Indicates nominal MST-1 minus (down) level of -1.85 Vdc; line should have solid down level or go to the down level.
  - [1] Plus (up) level is 0 Vdc and minus (down) level is -4 Vdc.
  - [2] Level is plus with cartridge open and minus with cartridge closed.
  - [3] Level is checked with LOAD REWIND switch held pressed.
  - [4] Replace per "Light Source Replacement", See 08-620. for page number.
  - [5] Plus (up) level is +6 Vdc and minus (down) level is 0 Vdc.
  - [6] Pulses from -1.3 Vdc to -1.6 Vdc.
  - [7] For tape units with modified power interface board and power supply see F1 an ALD page YB040 (60 Hz) or YB045 (50 Hz).
  - [8] Plus (up) level is +12 Vdc and minus (down) level is 0 Vdc.
  - [9] With EC 846437 either U10 or J06 can be + level for proper operation and pin J12 is unused.

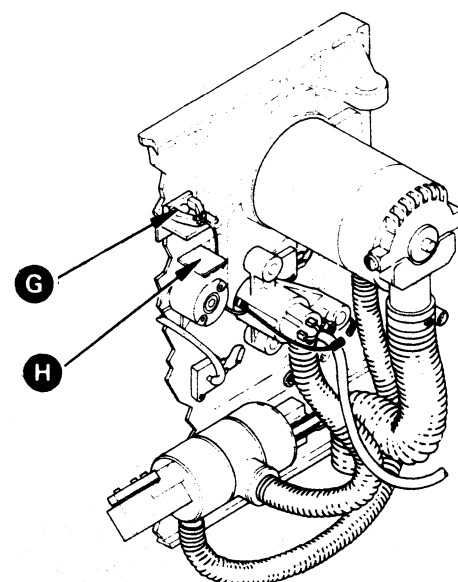
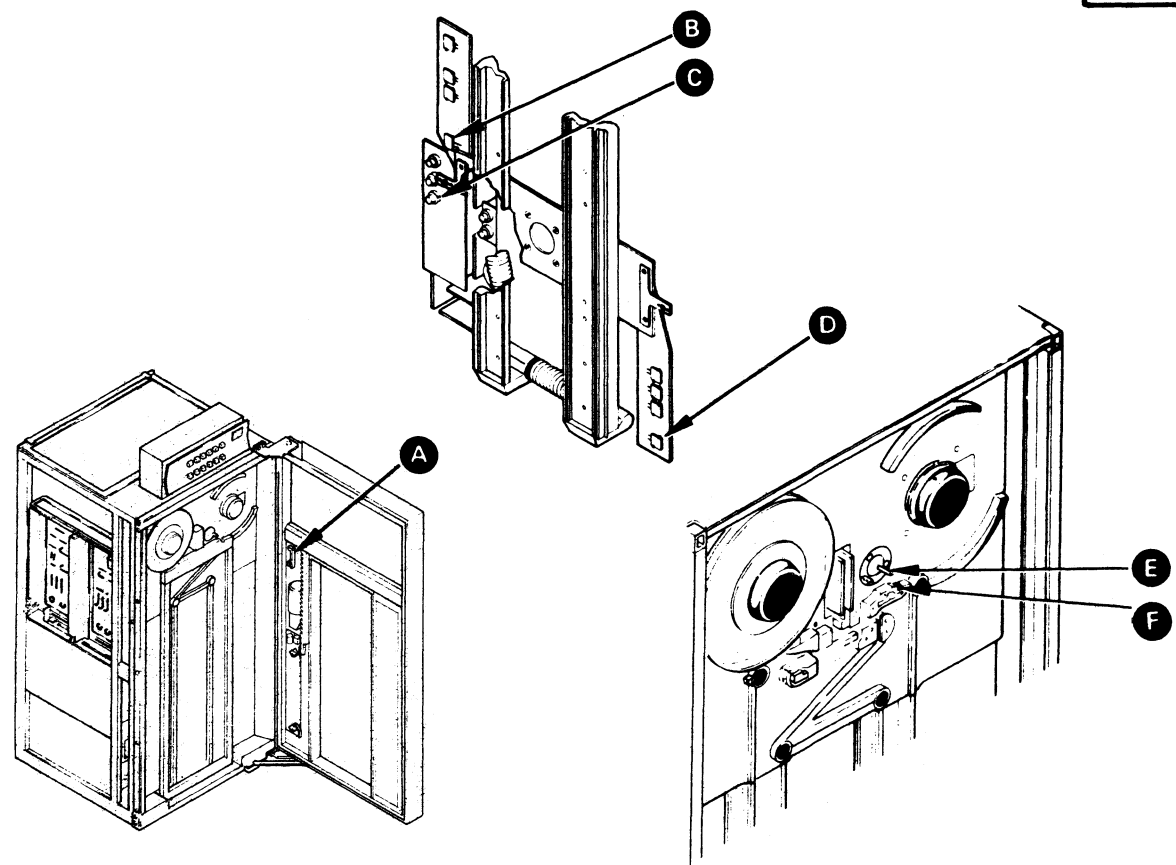

3803-1.2.3/3420

<b>XB1100</b>	<b>2735754</b>	<b>See EC</b>	<b>845958</b>	<b>846927</b>	<b>847298</b>		
Seq 2 of 2	Part Number	History	1 Sep 79	20 Jun 80	15 Aug 83		

© Copyright International Business Machines Corporation 1976, 1979, 1980, 1983



NOTES:

2A-105

3803-1.2.3/3420

XB1110 Seq 1 of 2	4169692 Part Number	See EC History	845958 1 Sep 79	846927 20 Jun 80	847298 15 Aug 83			
----------------------	------------------------	-------------------	--------------------	---------------------	---------------------	--	--	--

© Copyright International Business Machines Corporation 1976, 1979, 1980, 1983

2A-105

# LEFT REEL DOES NOT TURN CLOCKWISE AT THREADING SPEED

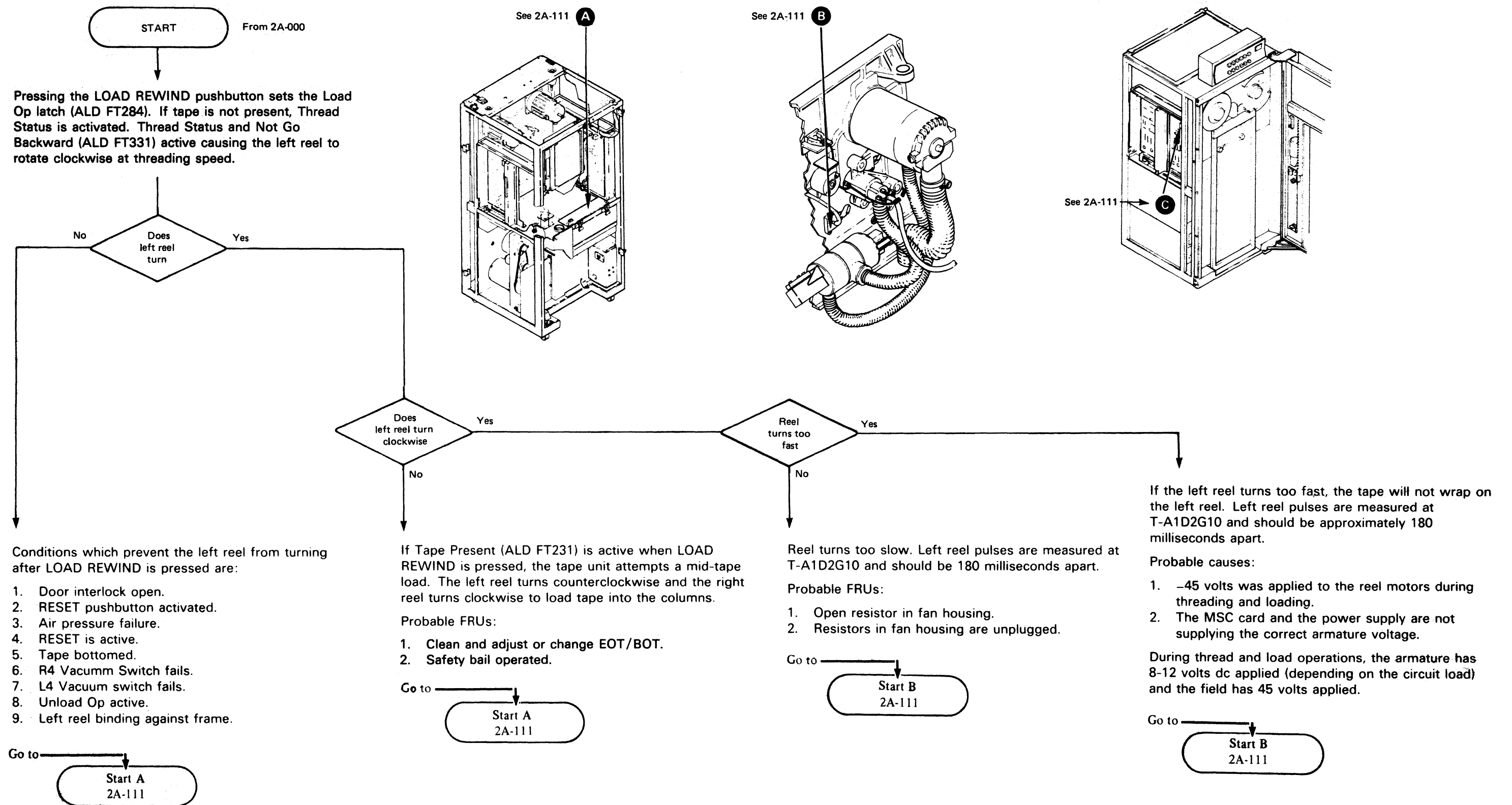

3803-1,2,3/3420

<b>XB1110</b>	<b>4169692</b>	<b>See EC</b>	<b>845958</b>	<b>846927</b>	<b>847298</b>		
Seq 2 of 2	Part Number	History	1 Sep 79	20 Jun 80	15 Aug 83		

© Copyright International Business Machines Corporation 1976, 1979, 1980, 1983

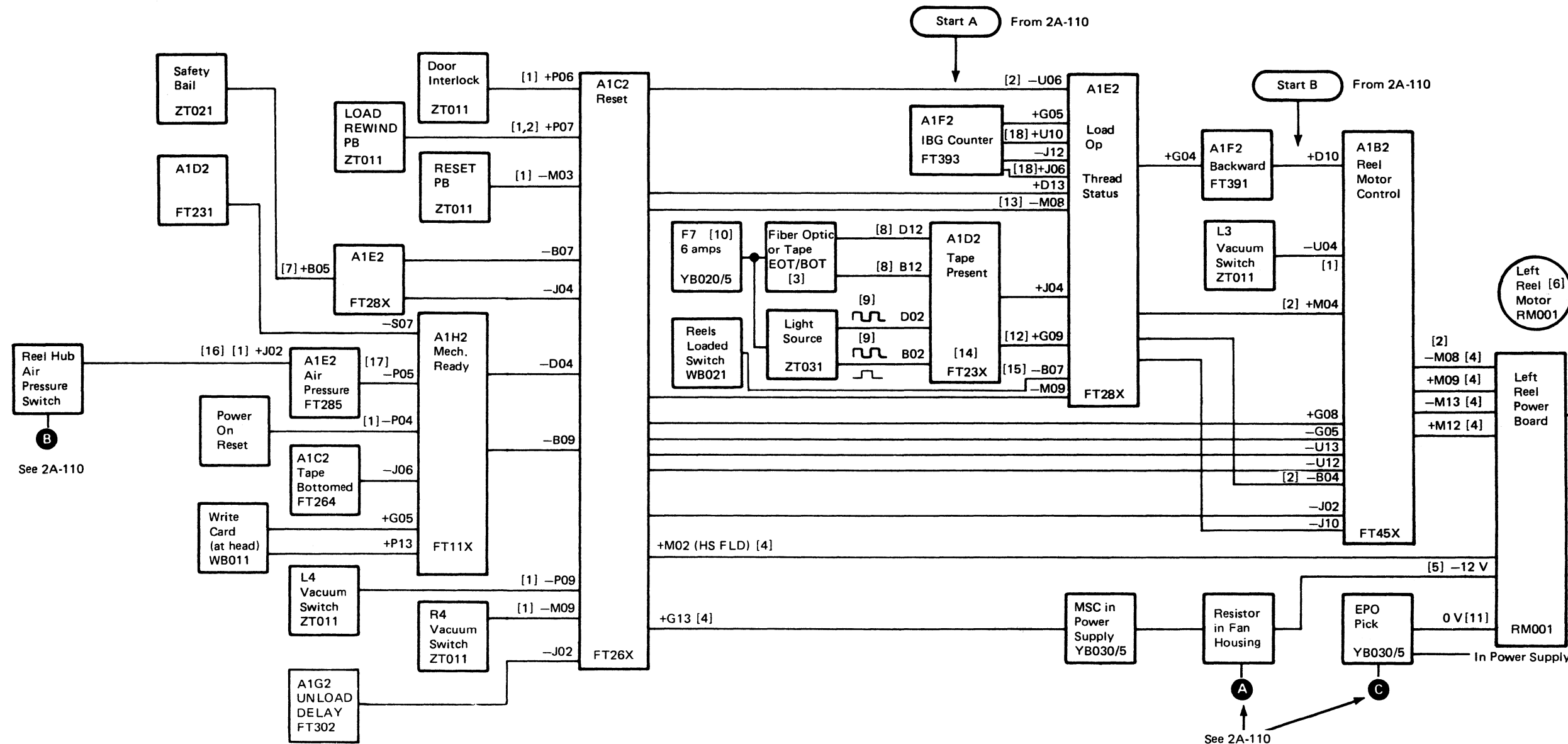

**Notes:**

- + Indicates nominal MST-1 plus (up) level of -0.85 Vdc; line should have solid up level or go to the up level.
- Indicates nominal MST-1 minus (down) level of -1.85 Vdc; line should have solid down level or go to the down level.
- [1] Plus (up) level is +0 Vdc and minus (down) level is -4 Vdc. Down level should be present with tape out of columns.
- [2] Level is checked with LOAD REWIND switch held pressed.

- [3] Before replacing the phototransistor, unplug the A1A3 cable. A voltage shift of approximately 0.1 Vdc at the T-A1D2 inputs indicates a good T-A1D2 card.
- [4] Plus (up) level is +12 Vdc and minus (down) level is 0 Vdc.
- [5] Measure at lower heat sink with motor plugged in. Voltage will be from -8 to -12 Vdc, depending on circuit load.  
**Caution: Voltage changes to -48 Vdc when the columns are loaded.**
- [6] Replace per "Left Reel Hub and Motor Replacement" procedures. See 08-560.

- [7] Plus (up) level is +6 Vdc and minus (down) level is 0 Vdc.
- [8] Typical voltage is +1.6 Vdc dark and less than +1.5 Vdc light.
- [9] Pulses from -1.3 Vdc to -1.6 Vdc.
- [10] For tape units with modified power interface board and power supply, see F1 on ALD page YB040 (60 Hz) or YB045 (50 Hz).
- [11] Measure at Reel Board J2-7.
- [12] Plus (up) level is +0.4 Vdc and minus (down) level is -4 Vdc.
- [13] Look at this before Load Check occurs.

- [14] If outputs are incorrect, do BOT/EOT adjustments on 08-580 before going to T-A1D2 inputs.
- [15] Special voltage line is zero (0) volts when the tape covers the port. It is -4 Vdc when the columns are loaded.
- [16] Plus with pneumatic supply running.
- [17] Minus with pneumatic supply running.
- [18] With EC 846437 either U10 or J06 can be + level for proper operation and pin J12 is unused.

3803-1,2,3/3420

<b>XB1200</b>	<b>2735755</b>	<b>See EC History</b>	<b>845958</b>	<b>846927</b>	<b>847298</b>
Seq 1 of 2	Part Number		1 Sep 79	20 Jun 80	15 Aug 83

NOTES:

2A-115

3803-1,2,3/3420

<b>XB1200</b> Seq 2 of 2	<b>2735755</b> Part Number	<b>See EC</b> <b>History</b>	<b>845958</b> 1 Sep 79	<b>846927</b> 20 Jun 80	<b>847298</b> 15 Aug 83			
-----------------------------	-------------------------------	---------------------------------	---------------------------	----------------------------	----------------------------	--	--	--

© Copyright International Business Machines Corporation 1976, 1979, 1980, 1983

2A-115



# RIGHT REEL DOES NOT TURN CLOCKWISE AT THREADING SPEED

If the right reel turns too fast, or turns counterclockwise with drive unloaded, check K2 on the manual status control (MSC) in the power supply.

As the left reel turns, pulses are generated by the radius sense photocell (ALD FT231). These pulses are gated to the interblock gap (IBG) counter (ALD FT39X) to monitor the threading operation.

At IBG count 4, the right reel starts turning clockwise at half speed.

Conditions that prevent the right reel from turning after the LOAD REWIND pushbutton is pressed are:

1. Tape present
2. Door interlock open
3. RESET pushbutton pressed
4. Safety bail operated
5. Air pressure failure
6. Reset is active
7. Tape bottomed
8. R4
9. L4
10. Unload Op is active
11. IBG advance trouble

Holding the LOAD REWIND pushbutton deactivates the input to the IBG counter preventing generation of IBG count 4. If a load check occurs before the reels are loaded, check for extraneous pulses from the radius sense photocell, or a defective F2 card.

If the right reel slips, check the reel latch diaphragm. A diaphragm leak may cause the reel to slip on the hub. A serious diaphragm leak keeps the Latch Manifold Pressure switch from transferring and the right reel does not turn.

Unless otherwise instructed, keep the left reel turning by pressing RESET and then the LOAD REWIND pushbuttons for each test point.

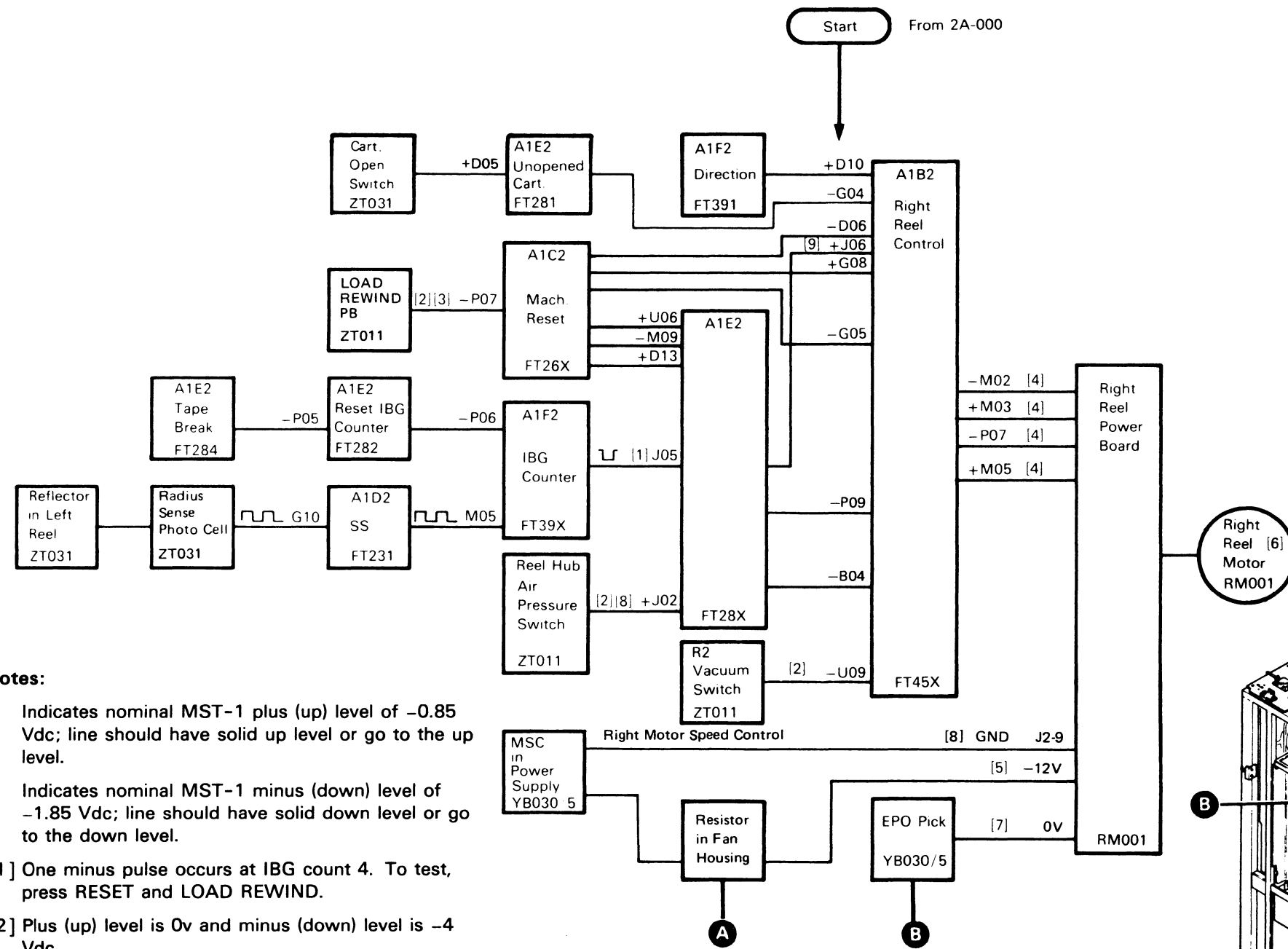

**Notes:**

- + Indicates nominal MST-1 plus (up) level of -0.85 Vdc; line should have solid up level or go to the up level.
- Indicates nominal MST-1 minus (down) level of -1.85 Vdc; line should have solid down level or go to the down level.

- [1] One minus pulse occurs at IBG count 4. To test, press RESET and LOAD REWIND.
- [2] Plus (up) level is 0v and minus (down) level is -4 Vdc.
- [3] Level is checked without pressing pushbutton.
- [4] Plus level is +12 Vdc and minus level is 0 Vdc.
- [5] Measure at lower heat sink with motor plugged in. Voltage will be from -8 Vdc to -12 Vdc depending on circuit load.

**Caution: Voltage switches to -48 Vdc when columns are loaded.**

- [6] Replace per "Right Reel Hub and Motor Removal and Replacement". See 08-560.
- [7] Measure at Reel Board J2-7.
- [8] Level is checked with the LOAD REWIND pushbutton held pressed.
- [9] Level is checked before Load Check.

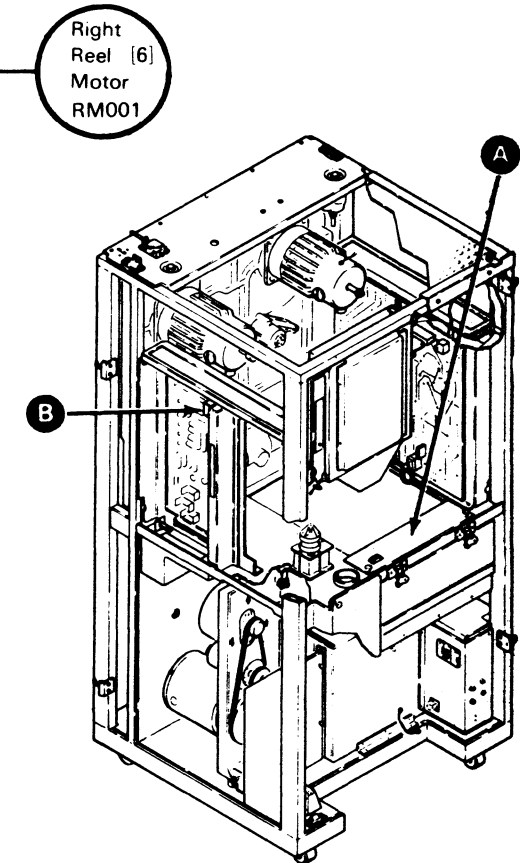

3803-1,2,3/3420

<b>XB1300</b> Seq 1 of 2	<b>2735756</b> Part Number	<b>See EC History</b>	<b>845958</b> 1 Sep 79	<b>846927</b> 20 Jun 80	<b>847298</b> 15 Aug 83			
-----------------------------	-------------------------------	-----------------------	---------------------------	----------------------------	----------------------------	--	--	--

# TAPE THREADS INTO RIGHT COLUMN

## (TRANSFER VALVE NOT PICKED OR PNEUMATIC MOTOR NOT RUNNING)

Load Op activates Pick Pneumatic Supply (ALD FT282), which energizes a contactor located in the ac power supply. Picking the contactor supplies power to the pneumatic motor driving the pressure pump and vacuum blower.

Thread Status actuates the transfer valve, which switches vacuum and directs pressure to the threading channels, preventing vacuum in the columns. Check transfer valve action by watching the transfer valve solenoid plunger from the rear of the machine.

- If the transfer valve is operating and there is still vacuum in the columns (see 08-400 Transfer Valve leakage test).
- If the transfer valve solenoid is not operating, check CP3 at the rear of the machine.

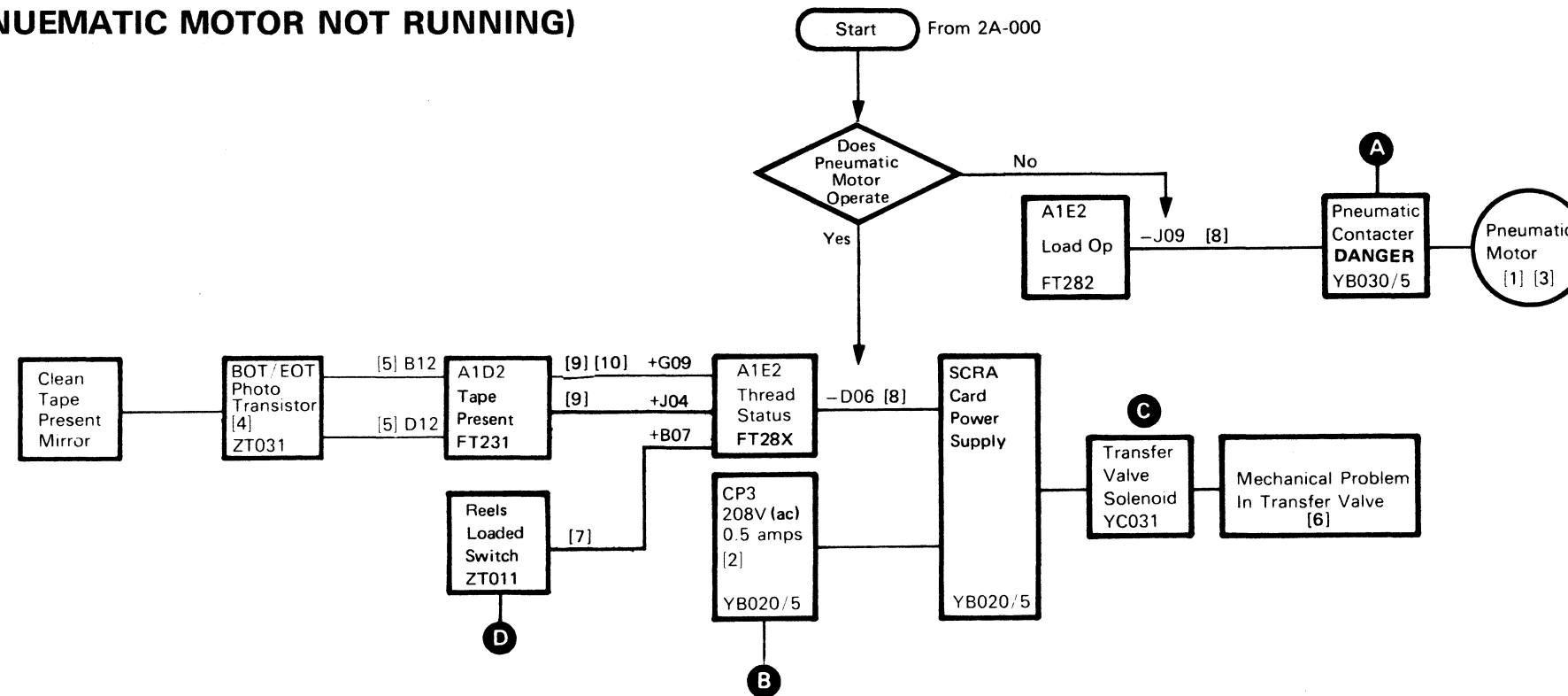

### Power Supply

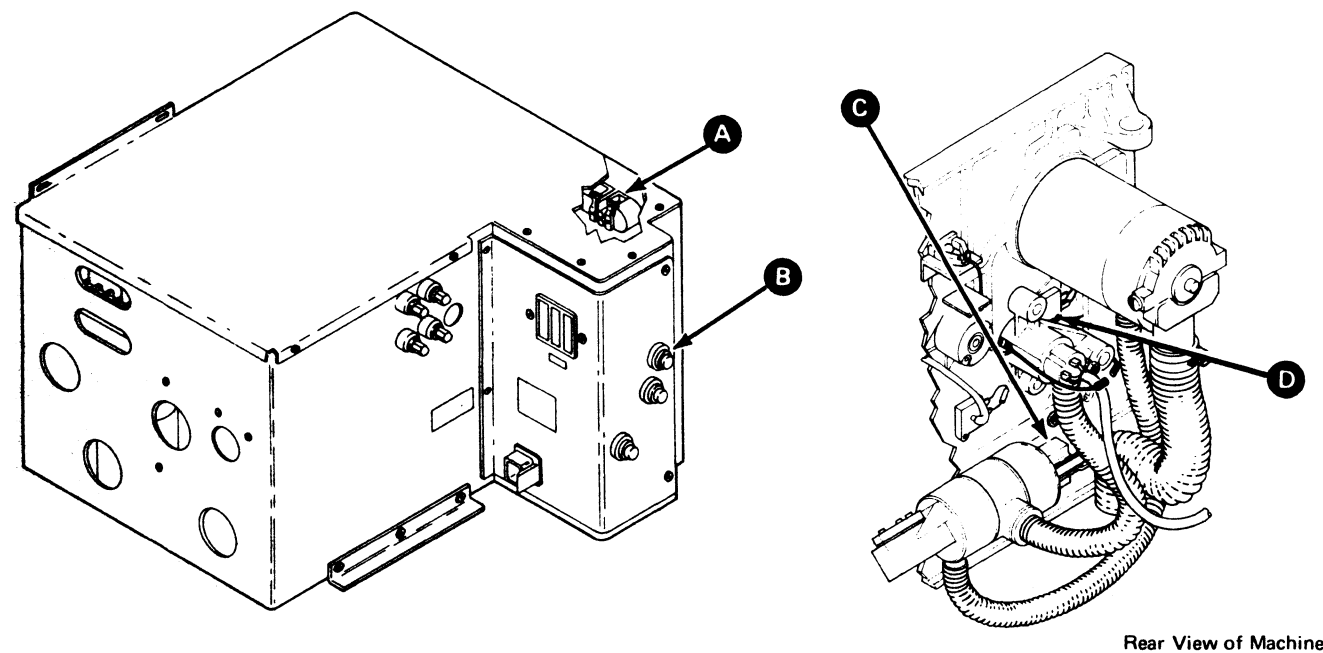

Rear View of Machine

### DANGER

Power must be removed completely. Remove the power cord when servicing inside the AC box.

### Notes:

- + Indicates nominal MST-1 plus (up) level of -.85 Vdc; line should have a solid up level or go to the up level.
- Indicates nominal MST-1 minus (down) level of -1.85 Vdc; line should have solid down level or go to the down level.
- [1] See ALD page YB030 (60 Hz) or YB035 (50 Hz).
- [2] CP3 is nonindicating and is not monitored by power check circuits.
- [3] Replace per "Pneumatic Supply Belt replacement and adjustment". See 08-440.
- [4] Before replacing the phototransistor assembly, unplug the T-A1A3 cable. A voltage shift of approximately 0.1 Vdc at the T-A1D2 inputs indicates a good T-A1D2 card.

- [5] Typical voltage level +1.6 Vdc dark, less than +1.5 Vdc light.
- [6] Check for leakage. (See "Pneumatic Pressure, Vacuum Checks" on 08-400).
- [7] Unload the tape unit and remove the tape reel. Press and hold the LOAD REWIND pushbutton to force and hold thread status. Cover and uncover the reels loaded port. The reading should be -4 Vdc uncovered and 0.0 Vdc covered.
- [8] Plus level is +12 Vdc; minus level is 0.0 Vdc.
- [9] If the level is incorrect, remove the tape. Perform the BOT/EOT adjustments before checking the T-A1D2 inputs. See 08-580 for the BOT/EOT adjustments.
- [10] Special voltage level is 0.0 Vdc to -4 Vdc.

3803-1,2,3/3420

<b>XB1300</b>	<b>2735756</b>	<b>See EC History</b>	<b>845958</b>	<b>846927</b>	<b>847298</b>			
Seq 2 of 2	Part Number		1 Sep 79	20 Jun 80	15 Aug 83			

© Copyright International Business Machines Corporation 1976, 1979, 1980, 1983

# TAPE THREADS INTO THREADING CHANNEL AND STOPS

The transfer valve remains actuated by Thread Status (ALD FT284) for two revolutions after the beginning-of-tape (BOT) marker is sensed. Possible causes are:

1. Obstructions in the read/write head area.
2. Left reel turning too fast. Check this condition on 2A-110.
3. Load check is set when the tape threads to the read/write head. Check for a defective Reels Loaded switch. The Reels Loaded switch is in the left thread channel.
4. Threading pressure or vacuum may be missing or low. See "Pneumatic Pressure, Vacuum Checks" on 08-400.
5. Tape may stick to lower restraint due to static.

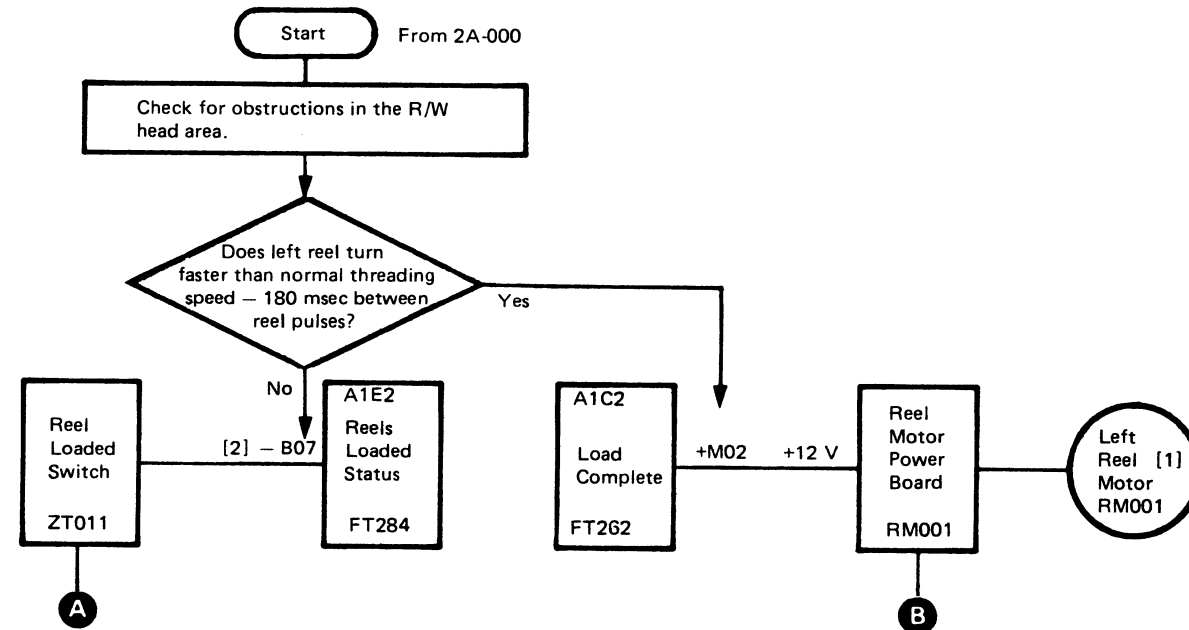

**Notes:**

- + Indicates nominal MST-1 plus (up) level of -0.85 Vdc; line should have solid up level or go to the up level.
- Indicates nominal MST-1 minus (down) level of -1.85 Vdc; line should have solid down level or go to the down level.

[1] Replace per "Left Reel Hub and Motor Removal and Replacement". See 08-560.

[2] Special voltage levels: -4 Vdc to ground. Line is at ground level only when tape covers the Reels Loaded switch sensing port. Line is at -4 Vdc when the tape unit is unloaded, or tape is loaded in the columns.

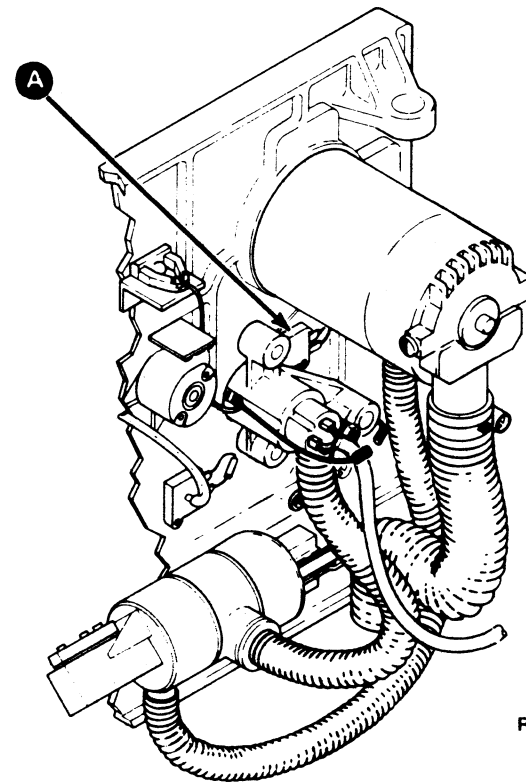

Rear view of machine

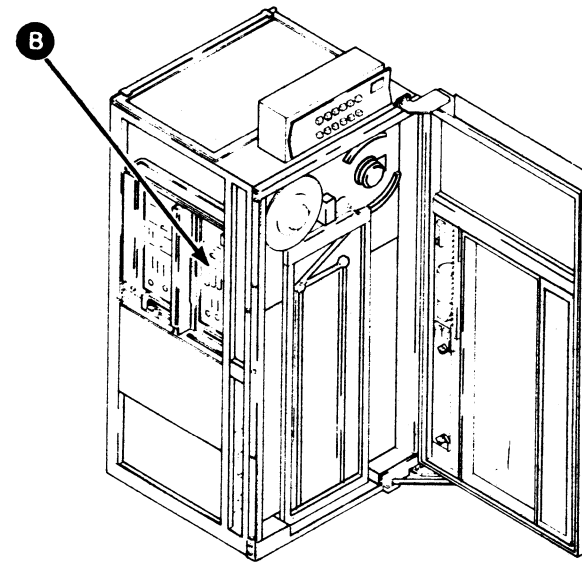

3803-1.2.3/3420

<b>XB1400</b>	<b>2735757</b>	<b>See EC</b>	<b>845958</b>	<b>846927</b>	<b>847298</b>			
Seq 1 of 2	Part Number	History	1 Sep 79	20 Jun 80	15 Aug 83			

© Copyright International Business Machines Corporation 1976, 1979, 1980, 1983

**LOAD CHECK PRIOR TO BOT SENSE**

A Load Check (ALD FT285) is caused by the incorrect stepping of the interblock gap (IBG) counter or sensor failure.

A slight tension develops when tape is firmly wrapped around the left reel with the right reel turning at half speed. Tension raises the tape and blocks the left guide sensing port, signaling a reels-loaded condition. Excessive leader length will cause a load check during a retry.

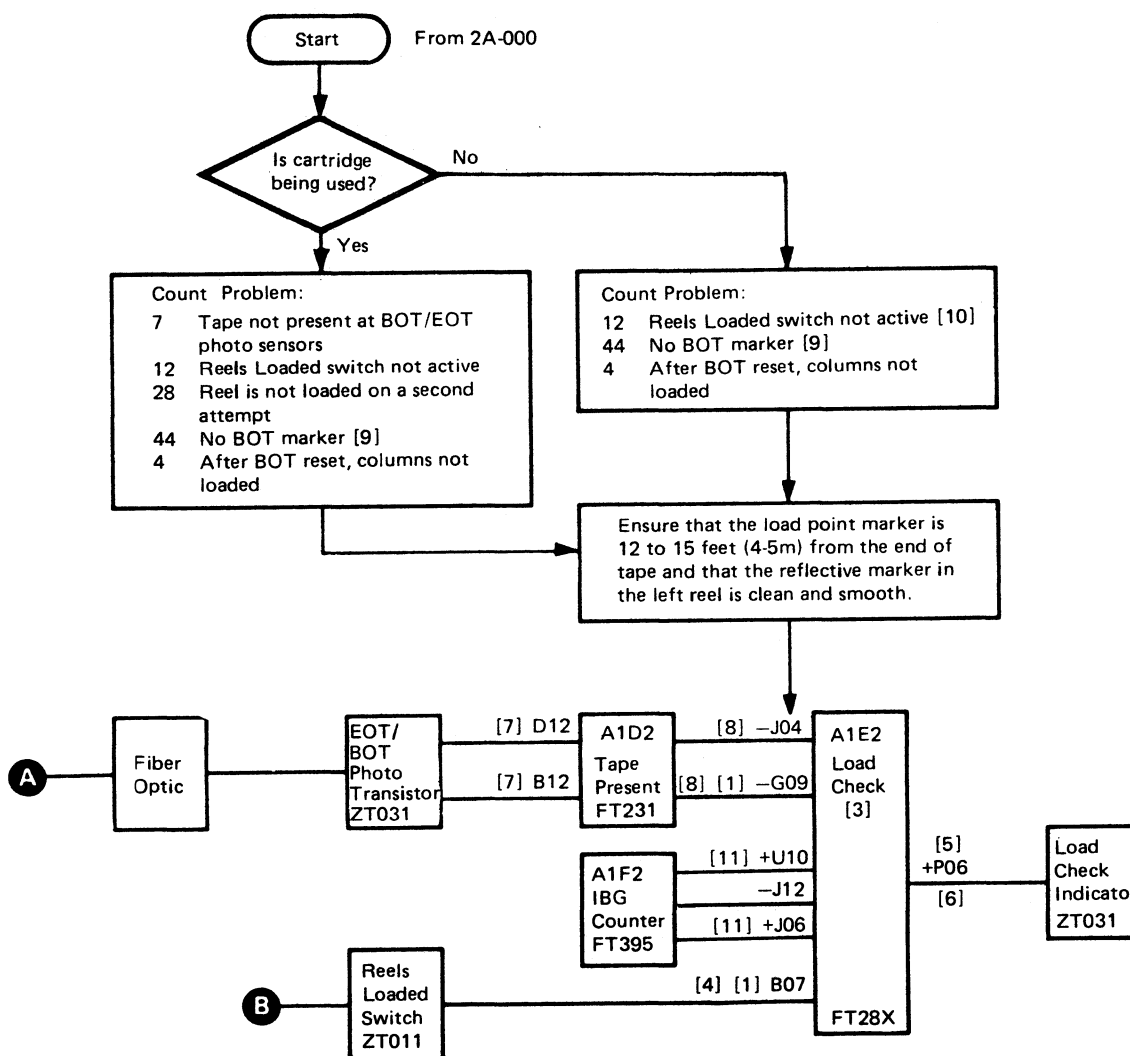
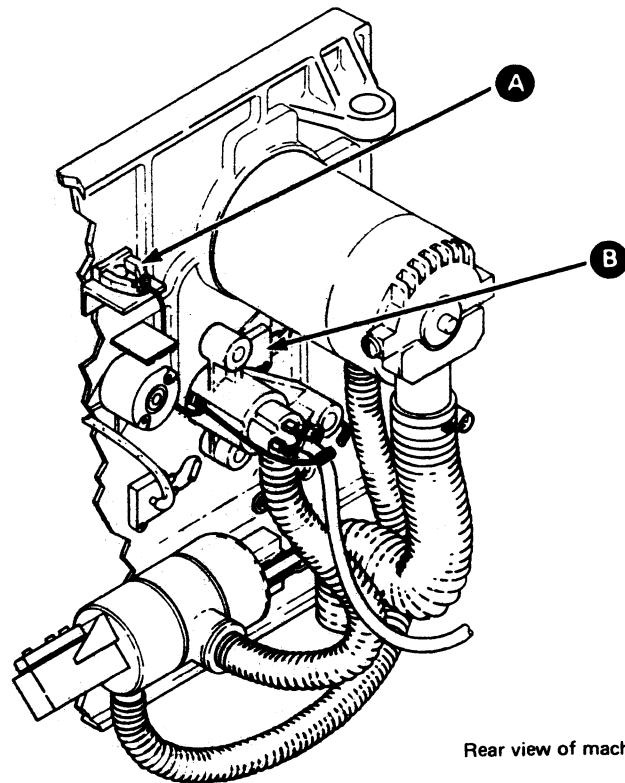

**Notes:**

- + Indicates nominal MST-1 plus (up) level of -0.85 Vdc; line should have solid up level or go to the up level.
- Indicates nominal MST-1 minus (down) level of -1.85 Vdc; line should have solid down level or go to the down level.
- [1] Plus (up) level is 0 Vdc and minus (down) level is -4 Vdc.
- [3] If the load check lamp stays on, change A1E2.
- [4] Line must go to 0 Vdc during threading operation. Line goes to -4 Vdc when pneumatics drop.
- [5] Special voltage levels: 0 Vdc to +12 Vdc.
- [6] + (plus) If LOAD CHECK indicator lamp is off.
- [7] Typical Voltage: +1.6 Vdc dark, less than +1.5 Vdc light.
- [8] If the level is incorrect, remove the tape. Perform the BOT/EOT adjustments before checking the T-A1D2 inputs. (See 08-580 for the BOT/EOT adjustments).
- [9] Without EC 846437 count is 36.
- [10] Without EC 846437 count is 9.
- [11] With EC 846437 either U10 or J06 can be + level for proper operation and PIN J12 is unused.

3903-1.2.3/3420					
<b>XB1400</b>	<b>2735757</b>	<b>See EC</b>	<b>845958</b>	<b>846927</b>	<b>847298</b>
Seq 2 of 2	Part Number	History	1 Sep 79	20 Jun 80	15 Aug 83



# TAPE DOES NOT LOAD INTO EITHER COLUMN

Reels continue to turn until the beginning-of-tape (BOT) marker is sensed. Output from the BOT phototransistor, along with Reels Loaded Status and Thread Status (ALD FT284), resets the interblock gap (IBG) counter to 0. The IBG counter resumes counting from 0. At BOT plus 2, Thread Status (ALD FT284) is reset and the transfer valve solenoid is de-energized, shifting vacuum to the columns and directing pressure to the air bearings. Not Thread Status and the Air Bearing Pressure switch transferred, stop the left reel from moving clockwise (ALD FT45X) and start it moving counterclockwise. With the left reel moving counterclockwise, Load Op sets Left Load Reversal, and tape loads into the columns.

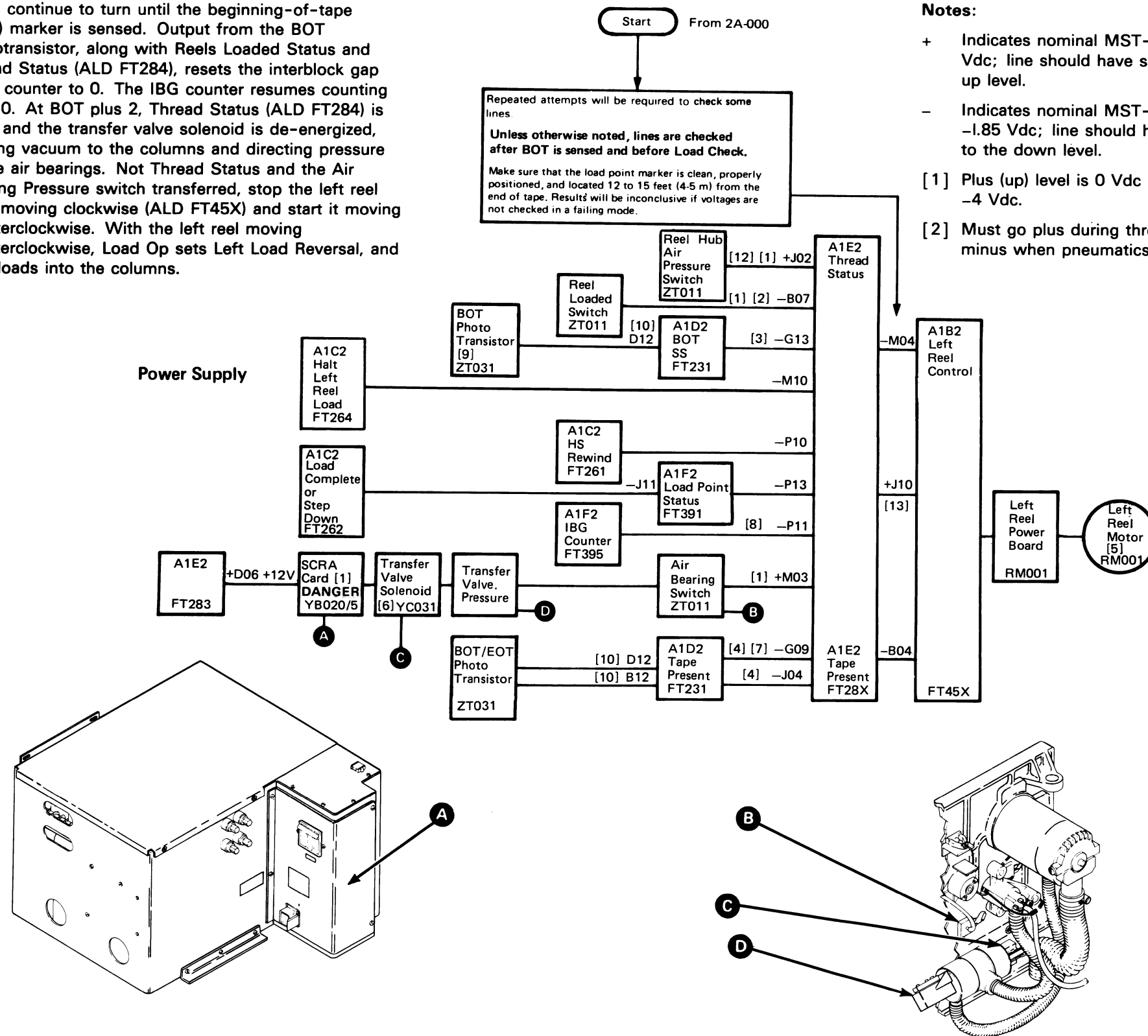

**Notes:**

- + Indicates nominal MST-1 plus (up) level of -0.85 Vdc; line should have solid up level or go to the up level.
- Indicates nominal MST-1 minus (down) level of -1.85 Vdc; line should have solid down level or go to the down level.
- [1] Plus (up) level is 0 Vdc and minus (down) level is -4 Vdc.
- [2] Must go plus during threading operations. Goes minus when pneumatics drop.

- [3] When the BOT marker passes the sensor, a negative pulse is generated. The BOT singleshot line is plus when the tape is stopped. If the BOT singleshot line is incorrect, perform the BOT/EOT adjustment before checking the T-A1D2 inputs. (See 08-580 for BOT/EOT adjustments).
- [4] If the level is incorrect, perform the BOT/EOT adjustments checking the A1D2 inputs. (See 08-580 for BOT/EOT adjustments).
- [5] Replace per "Left Reel Hub and Motor removal/Replacement/Adjustment". See 08-560.
- [6] Transfer valve solenoid should not be energized. If the transfer valve solenoid stays picked, the probable cause is a shorted resistor/capacitor (RC) network across the K1-5 and K1-9 relay points on the SCRA card (see YC031). Use improved RC network (P/N 1766179).
- [7] Special voltage level: 0 Vdc to -4 Vdc.
- [8] Must pulse minus during thread operation.
- [10] Typical voltage level: +1.6 Vdc dark, less than +1.5 Vdc light.
- [11] This is the SCRA card located inside the ac power supply.
- DANGER**  
Power must be removed completely. Remove the power cord when servicing inside the AC box.
- [12] Check air pressure at the rear of the housing prior to changing the air pressure switch. (See 08-520).
- [13] Line is plus during a Load or Unload operation.

3803-1,2,3/3420

<b>XB1500</b> Seq 1 of 2	<b>2735758</b> Part Number	<b>See EC History</b>	<b>845958</b> 1 Sep 79	<b>846927</b> 20 Jun 80	<b>847298</b> 15 Aug 83		
-----------------------------	-------------------------------	-----------------------	---------------------------	----------------------------	----------------------------	--	--

**Symptom:** Tape bottoms or pulls out of columns or does not load into column.

**Comments:** Tape loads into the column after the 670 ms singleshoot times out, putting the reels under complete column control. Columns Loaded Status and Load Complete (FT451) are set with the tape above R4 and L4 and below R1 and L2. Load Complete conditions Go Internal for a low speed rewind back to load point under capstan control (FT391). Make sure the vacuum column door is tightly closed while loading. If tape fails to load into one column, see 08-800 for vacuum column balance adjustment.

**SET UP:**

1. Check to ensure right reel is not slipping on the hub with columns loaded.

2. **Caution:**

**Do not let tape touch the capstan under any circumstance, or the capstan may be severely damaged during the following setup.**

Fasten a short strip of magnetic tape in each vacuum column so it forms a loop halfway down each column as follows:

Anchor one end of each tape strip to its respective stubby column. Then route the tape halfway down and back out of the column by looping over the reel tachs. Anchor these ends with transparent or masking tape. Cut tape over-all length to allow for later adjustment to the bottom of the vacuum column. (See 08-450 for an illustration of the procedure).

Block the BOT/EOT with a piece of card. Cover the reels loaded port with a piece of transparent or masking tape.

- With power up, press RESET. Press LOAD REWIND twice, and then press START.
- Press RESET, LOAD REWIND, and START again. The Ready lamp should not come on. If it does, replace T-A1F2.

**Notes:**

+ Indicates nominal MST-1 plus (up) level of -0.85 Vdc; line should have solid up level or go to the up level.

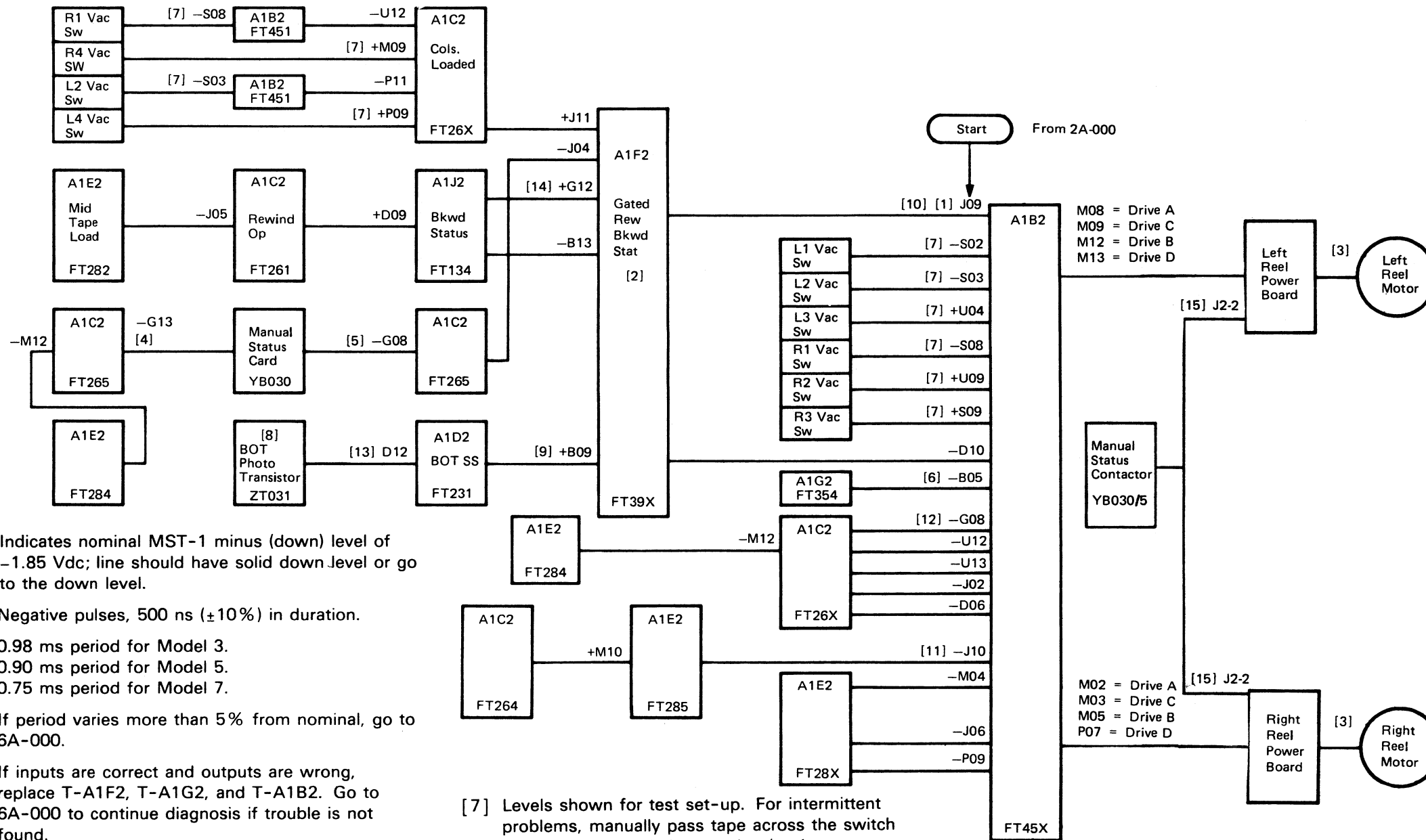

Indicates nominal MST-1 minus (down) level of -1.85 Vdc; line should have solid down level or go to the down level.

[1] Negative pulses, 500 ns (±10%) in duration.

0.98 ms period for Model 3.  
0.90 ms period for Model 5.  
0.75 ms period for Model 7.

If period varies more than 5% from nominal, go to 6A-000.

- If inputs are correct and outputs are wrong, replace T-A1F2, T-A1G2, and T-A1B2. Go to 6A-000 to continue diagnosis if trouble is not found.
- Reel power boards may be exchanged between tape units if the reel power board part numbers are identical.
- Special voltage, +12 Vdc to 0 Vdc.
- Special voltage, -0.5 Vdc to -2.5 Vdc.
- Press RESET. Level should go plus. Press LOAD REWIND and START before continuing.

[7] Levels shown for test set-up. For intermittent problems, manually pass tape across the switch ports to check switch operation (+ above - below). Positioning the tape loop so it intersects the port may cause this vacuum switch to oscillate. Using internal sync, check the condition of the switch contacts. Special voltage: 0 Vdc to -4 Vdc.

[9] If the level is incorrect, perform the BOT/EOT adjustment before checking the T-A1D2 cards inputs. (See 08-580).

[10] Press the RESET pushbutton; the level should go to -0.8 Vdc. Repeat step 3 before continuing.

[11] Check T-A1E2M10 for positive level at the same time.

[12] Check T-A1C2M12 at the same time.

[13] Typical voltage levels: +1.6 Vdc dark, less than +1.5 Vdc light.

[14] Line is tested without Ready condition.

[15] J2-2 is -12 Vdc with drive loaded, 0.0 Vdc if unloaded. J2-1 is -12 Vdc while drive is unloaded or threading and -45 Vdc while drive is loaded and reel motors not being driven.

3803-1,2,3/3420

<b>XB1500</b>	<b>2735758</b>	<b>See EC</b>	<b>845958</b>	<b>846927</b>	<b>847298</b>		
Seq 2 of 2	Part Number	History	1 Sep 79	20 Jun 80	15 Aug 83		

© Copyright International Business Machines Corporation 1976, 1979, 1980, 1983

# TAPE DOES NOT GO BACKWARD OR DOES NOT STOP AT BOT

Column Loaded Status and Load Complete are set with the tape above R4 and L4 and below R2 and L2 vacuum column ports. Load Complete conditions Go Internal (FT391) and resets Manual Status (FT 265). When the beginning-of-tape (BOT) marker is sensed going backwards, Load Point Status (FT391) is set, dropping Go Internal, stopping the tape.

### SET UP:

1. Install tape loops as stated in 2A-170 and illustrated on 08-450.
2. Press LOAD REWIND. Press RESET twice, and then START. Then press RESET and LOAD REWIND again. The capstan should run backwards.
3. If the failure is not stopping at BOT, momentarily ground T-A1D2D12 to set Load Point Status. Capstan should stop.

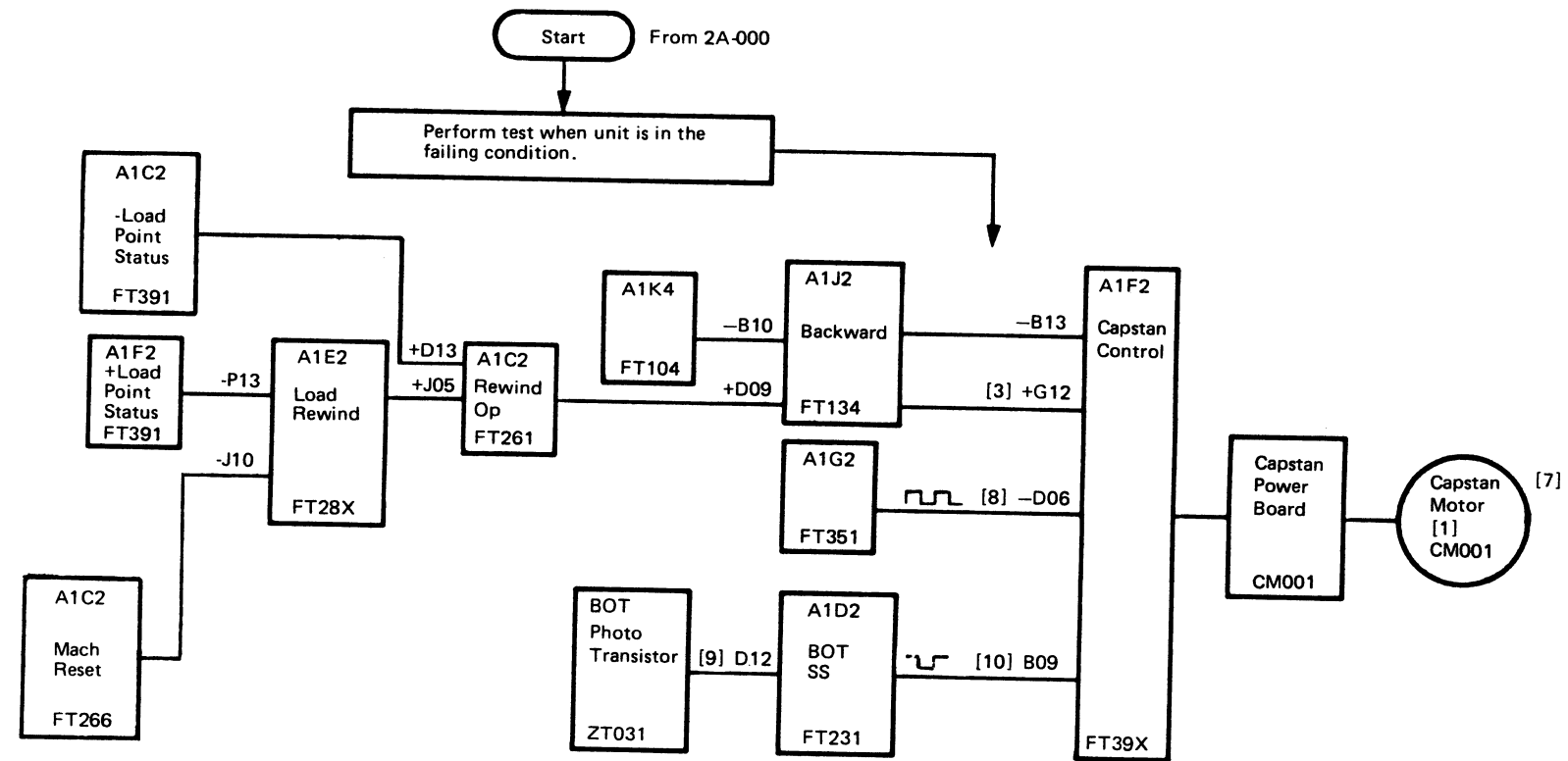

### Notes:

- + Indicates nominal MST-1 plus (up) level of -0.85 Vdc; line should have solid up level or go to the up level.
- Indicates nominal MST-1 minus (down) level of -1.85 Vdc; line should have solid down level or go to the down level.
- [1] Replace per "Capstan Assembly Replacement". See 08-000 for appropriate tape unit series procedures.
- [2] See ALD YB010/5 and YB030/5.

- [7] If the problem is not fixed, check the -48 Vdc power supply by scoping for excessive spikes (3 Vdc or greater).
- [8] Line has pulses if the capstan is moving, it stays minus if the capstan is not moving.
- [9] Typical voltage level: +1.6 Vdc dark and less than +1.5 Vdc light.
- [10] A minus pulse is generated when the BOT marker passes the sensor. If the line level is incorrect, remove the tape. Perform the BOT/EOT adjustment Before checking the T-A1D2 input. (See 08-580 for the BOT/EOT adjustment).

3803-1.2.3/3420

XB1600	2735759	See EC	845958	847298				
Seq 1 of 2	Part Number	History	1 Sep 79	15 Aug 83				

© Copyright International Business Machines Corporation 1976, 1979, 1983

# TAPE GOES FORWARD AFTER LOADING INTO VACUUM COLUMNS

If tape goes forward after loading into columns,  
Backward Status was not set (ALD FT134).

**Normal Sequence:**

1. Beginning-of-tape (BOT) phototransistor output resets Thread Status (ALD FT284).
2. Resetting Thread Status sets Load Rewind (ALD FT282), which then sets Rewind Op (ALD FT261).
3. Rewind Op sets Backward Status, causing the tape to move backward.

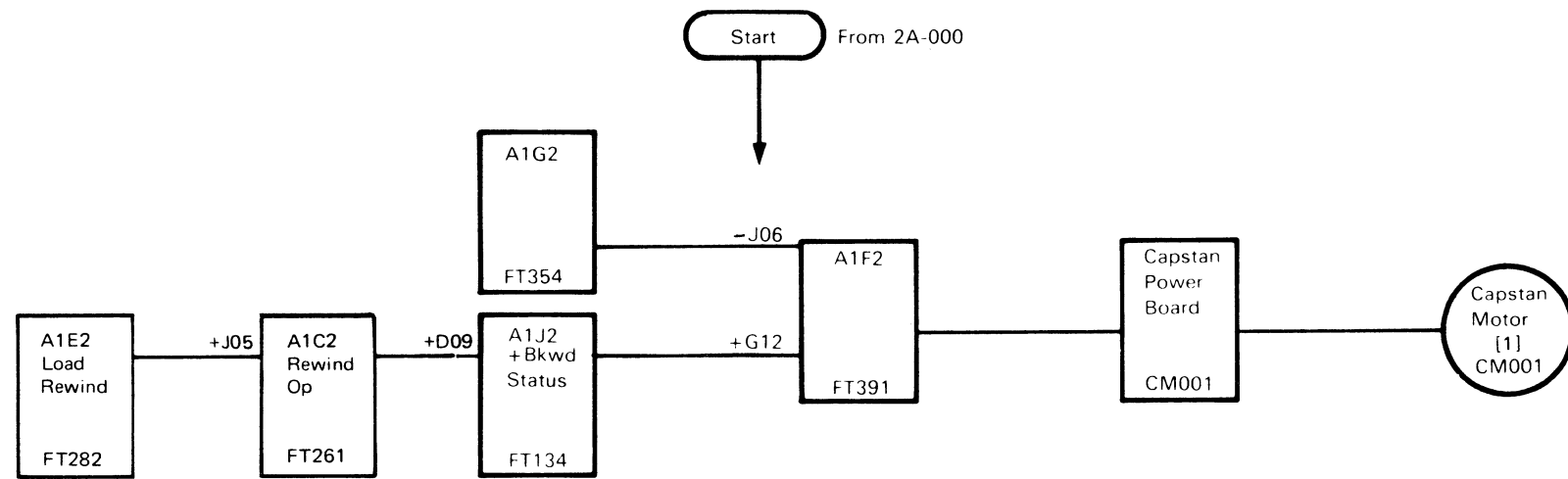

**Notes:**

- + Indicates nominal MST-1 plus (up) level of -0.85 Vdc; line should have solid up level or go to the up level.
- Indicates nominal MST-1 minus (down) level of -1.85 Vdc; line should have solid down level or go to the down level.
- [1] Replace per "Capstan Assembly Replacement". See 08-000.

3803-1,2,3/3420

<b>XB1600</b>	<b>2735759</b>	<b>See EC</b>	<b>845958</b>	<b>847298</b>				
Seq 2 of 2	Part Number	History	1 Sep 79	15 Aug 83				

© Copyright International Business Machines Corporation 1976, 1979, 1983

# READY LAMP DOES NOT TURN ON/ WINDOW DOES NOT CLOSE

- Load Op (ALD FT284) is reset by Load Complete.
- Columns Loaded keeps the pneumatic supply operating.
- Pressing START sets the Ready latch (ALD FT262).
- The Ready latch gated by Window Closed turns on the Ready indicator. (ALD FT261)

### SET UP:

1. Mount tape.
2. Press LOAD REWIND pushbutton.
3. Press START pushbutton.

### Notes:

- + Indicates nominal MST-1 plus (up) level of -0.85 Vdc; line should have solid up level or go to the up level.
- Indicates nominal MST-1 minus (down) level of -1.85 Vdc; line should have solid down level or go to the down level.

- [1] Plus (up) level is +0 Vdc and Minus (down) level is -4 Vdc.
- [2] Test with START pushbutton pressed.
- [3] Up level is +6 Vdc and down level is 0 Vdc.
- [4] Test with tape at load point. Check for +4.2 Vdc or greater at T-A1D2D11.
- [5] Check fuse/circuit protector, Up and Down switches, safety bail switch, window motor, Printed Circuit Board, and replace logic card at T-A1E2 and T-A1C2.
- [6] If problem is not fixed, suspect a missing voltage, or one or more power supply voltages out of tolerance. Go to 1A-000.
- [7] Minus level is 0.0 Vdc to +0.5 Vdc. Plus level is 12 Vdc.

**DANGER**  
Power must be completely removed. Remove the power cord when servicing inside the AC box.

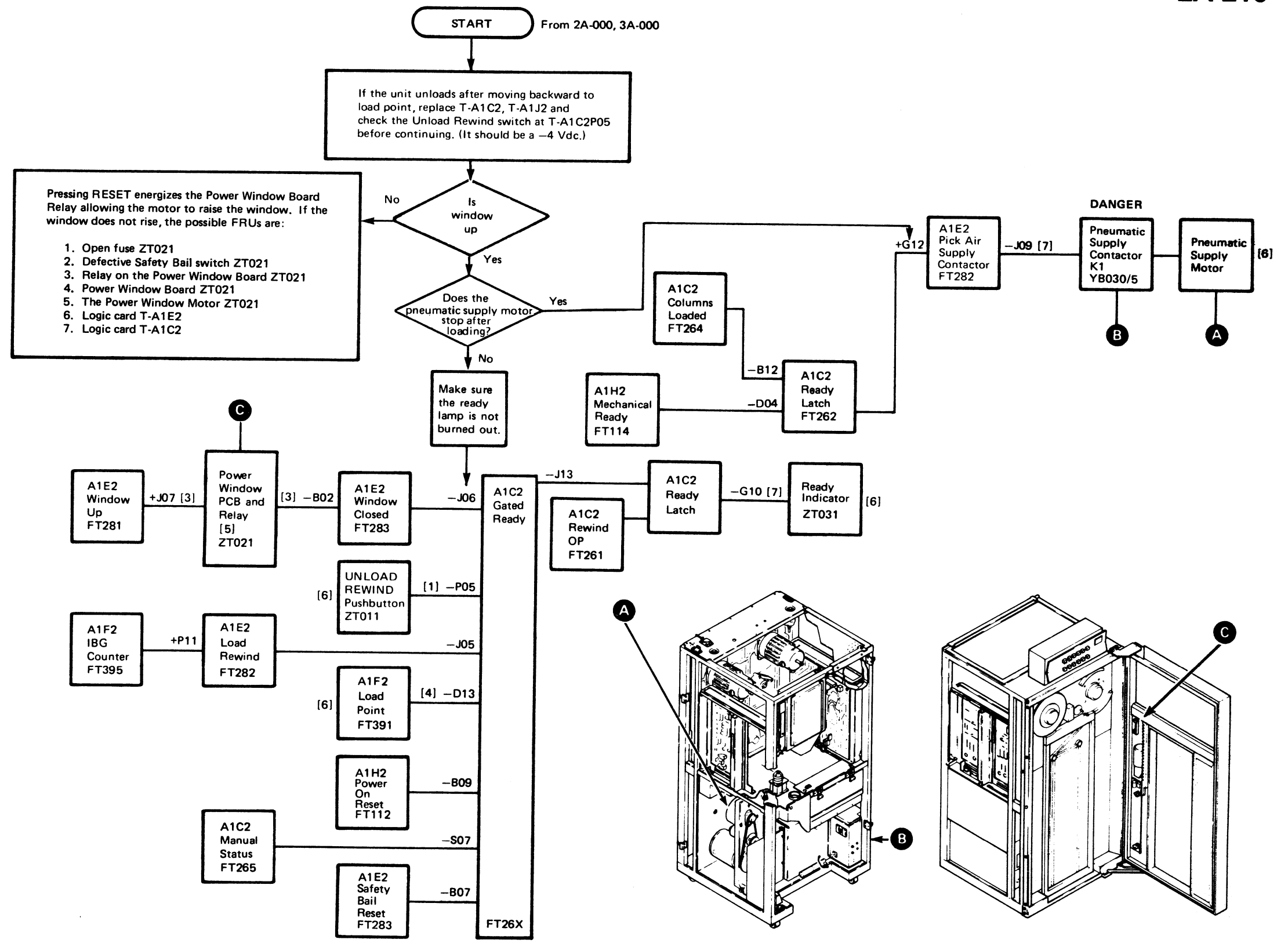

3803-1,2,3/3420						
XB1700	2735760	See EC	845958	846927	847298	
Seq 1 of 2	Part Number	History	1 Sep 79	20 Jun 80	15 Aug 83	

NOTES:

2A-211

3803-1,2,3/3420

<b>XB1700</b> Seq 2 of 2	<b>2735760</b> Part Number	<b>See EC</b> <b>History</b>	<b>845958</b> 1 Sep 79	<b>846927</b> 20 Jun 80	<b>847298</b> 15 Aug 83			
-----------------------------	-------------------------------	---------------------------------	---------------------------	----------------------------	----------------------------	--	--	--

© Copyright International Business Machines Corporation 1976, 1979, 1980, 1983

2A-211



# TAPE MOTION AND REWIND SYMPTOMS

3A-000

From 00-040, 2A-000		
<b>Possible causes:</b>		
<ol style="list-style-type: none"> <li>1. Bad transfer valve.</li> <li>2. Leakage in the pneumatic system.</li> <li>3. Capstan squaring.</li> <li>4. Low pressure or vacuum.</li> <li>5. Loose belts.</li> <li>6. T-A1F2, T-A1C2, T-A1K4.</li> </ol>		
<p><b>Always</b> start with Seq 1 and follow the procedure in sequence unless directed otherwise.  <b>Remember</b> to END all problem or maintenance calls by going to MAP 00-030.</p>		
Seq	Condition/Instruction	Action
1	Set up field tester for Write, 16, Forward, and Go.	
2	Does the tape move forward properly?	Go to Seq 5.
3	Tape does not respond or moves backward on a forward operation?	Go to 3A-100.
4	If not:	Go to 3A-110.
5	Change field tester from GO to STOP.	
6	Does tape stop?	Go to Seq 8.
7	If not:	Go to 3A-140.
8	Set up field tester for Read, 16, Backward, and Go. Make sure tape is away from load point.	
9	Does tape move backward properly?	Go to Seq 12.
10	Does tape fail to go backward?	Go to 3A-130.
11	If not:	Go to 3A-110.
12	Change field tester setup to Write, 16, Forward and Go.	
13	Does tape reverse and go forward?	Go to Seq 15.
14	If not:	Go to 3A-100.
15	Does motion stop at End-of-Tape (EOT) marker?	Go to Seq 18.
16	Does tape unwind off the end of the right reel?	Go to 3A-150.
17	If not:	Recheck symptoms.
18	Change field tester setup to Reset, Load Rewind, and Start.	
19	Does the tape move backward?	Go to Seq 21.
20	If not:	Replace T-A1C2, T-A1J2, T-A1K4. Go to 00-030.

Seq	Condition/Instruction	Action
21	Do the READY and the Tape Indicate lamps go out?	Go to Seq 24.
21A	Does the tape bottom, bobble, or pull out of the left column?	Go to 3A-110.
22	Does the ready indicator stay on?	Go to 4A-100.
23	If Not:	Go to 3A-150.
24	Does tape enter and stabilize in high speed rewind status, during high speed rewind?	Go to Seq 26.
25	If not:	Go to Seq 31.
26	Does tape pull out of the stubby column when going from a high speed to a low speed rewind? See Figure 1.	Go to 6A-010.
27	After the high speed rewind, does tape rewind at normal speed to beginning-of-tape BOT? <b>Note: (Capstan Tach)</b> Model 3—12.8 tach pulses/ms.* Model 5—13.3 tach pulses/ms. Model 7—21.3 tach pulses/ms. <b>*Low speed rewind only:</b> Normal tape motion is 8.0 tach pulses/ms.	Go to Seq 29.
28	If not:	Go to Seq 31.
29	Does tape stop at BOT with READY lamp on?	Go to 00-030.
30	If not:	Go to 2A-210.
31	Does tape pull out, dump, or move with wide excursions in the left column?	Go to 3A-160.
32	Does tape enter and stay in high speed rewind status?	Go to Seq 34.
33	If not:	Go to 3A-170.
34	Does tape rewind to BOT at high speed?	Go to 3A-170.
35	Is the problem intermittent?	Go to 2A-005.
36	If not:	Recheck symptoms.

Figure 1. Backward Continuous

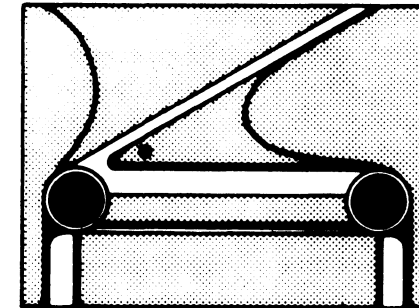

Figure 1 indicates a dirty (plugged) left air bearing, low air bearing pressure, high vacuum, or improper vacuum column door glass adjustment.

3803-1,2,3/3420

XB1800 Seq 1 of 2	2735761 Part Number	See EC History	845958 1 Sep 79	846927 20 Jun 80	847298 15 Aug 83		
----------------------	------------------------	-------------------	--------------------	---------------------	---------------------	--	--

© Copyright International Business Machines Corporation 1976, 1979, 1980, 1983

3A-000

During a rewind operation, the tape reels turn backward at either high or low speed until tape is rewound on the file reel. The operation ends when a photocell senses the beginning-of-tape (BOT) or load point reflective marker. A low speed rewind occurs when there is less than one-half inch of tape (12.7mm) on the machine reel. Tape moves backward to load point at normal reading and writing speed. Model 3, see 3A-030. A high speed rewind occurs when there is more than one-half inch of tape on the machine reel. Tape moves backward at approximately 500-600 ips for Models 3 and 5, and approximately 700-800 ips for Model 7 until less than one-half inch (12.7mm) of tape remains on the machine reel. Rewind then continues at low speed until the load point is reached.

**INITIATING A REWIND**

A rewind operation is started by a Rewind command from the tape control or by pressing RESET then UNLOAD REWIND or LOAD REWIND.

A rewind operation starts with a forward motion if tape has not moved for 12 milliseconds or longer. In this instance, the capstan moves tape forward for 8 quarter tach counts, reverses direction, and accelerates to normal backward velocity.

The left reel turns counterclockwise to feed tape into the left column when the left column loop goes above the L2 port. The right reel turns counterclockwise to take up the tape from the right column when the right column loop goes below the R2 port.

**HIGH SPEED REWIND**

The High Speed Field (HSFL) latch is set after both the right reel and the left reel have exceeded the capstan speed. The HSFL overrides the capstan control circuits and holds the Capstan Count and Fast triggers reset to prevent Capstan Coast.

During high speed rewind, Rewind Current and Step Down Current are controlled by the reel/capstan speed comparison circuit.

**LOW SPEED REWIND PORTION**

The high speed rewind ends when enough tape is removed from the left reel to activate the radius sense photocell, which, in turn activates HS Stepdown. During stepdown, the capstan speed follows the speed of the reel which slows down until the capstan drops below normal velocity. Capstan motion then continues under normal control until the BOT reflective marker is reached.

Pressing RESET also activates HS Stepdown, Holding RESET pressed or pressing RESET a second time stops tape.

**Rewind Timing Chart**

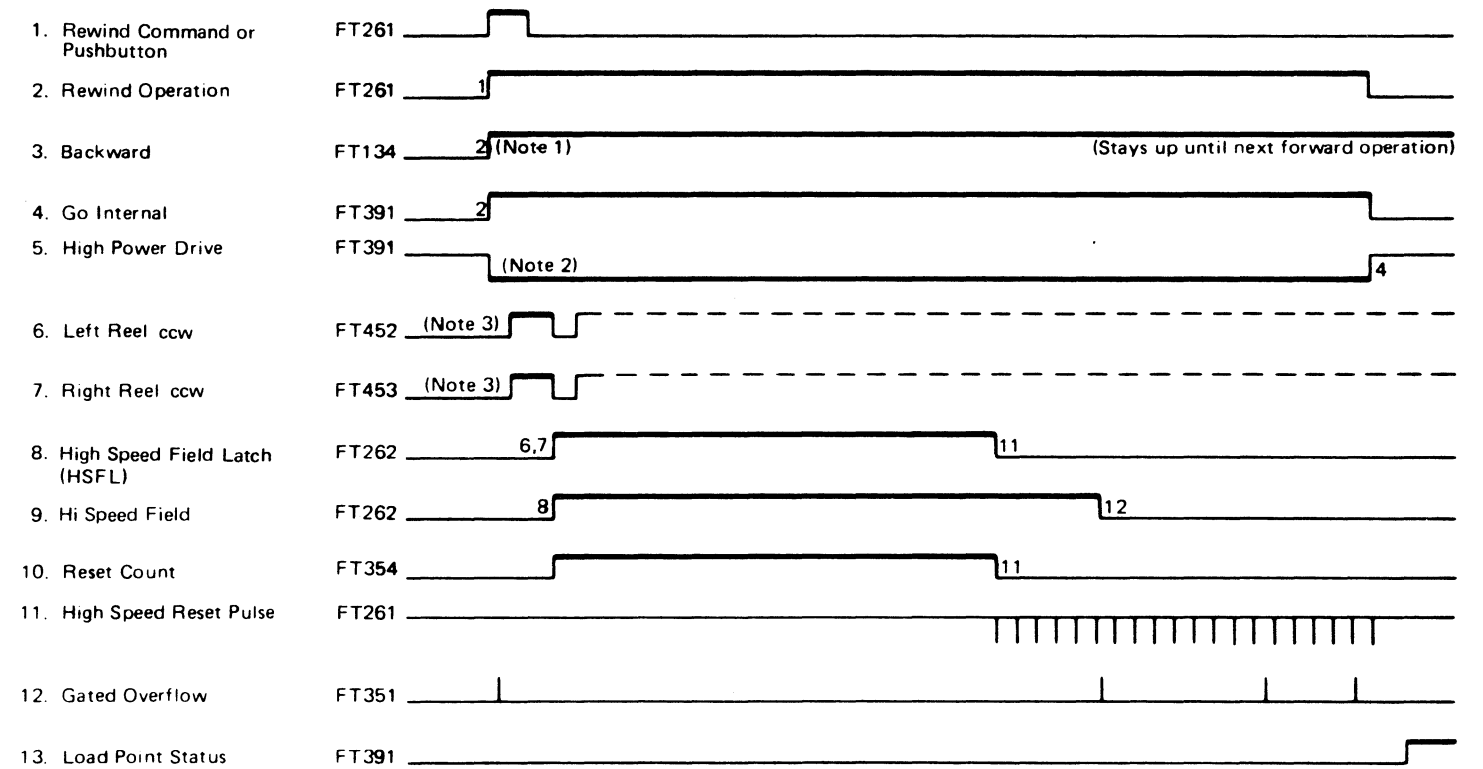

**Notes:**

1. If Go Internal is down for 12 ms or more, tape motion starts with a forward motion.
2. Reset by first Capstan Fast pulse.
3. Controlled by vacuum column port sensing.

XB1800 Seq 2 of 2	2735761 Part Number	See EC History	845958 1 Sep 79	846927 20 Jun 80	847298 15 Aug 83			
----------------------	------------------------	-------------------	--------------------	---------------------	---------------------	--	--	--



## REEL DRIVE SYSTEM

3A-020

The reel drive system includes:

- Reel motors and drivers
- Reel stabilization circuits
- Reel tachometers (reel tachs)
- Vacuum sensing switches

The reel drive system operates in Manual status to thread, load, and unload the tape unit and is in Not Manual status for all other operations. Manual status is identified in the tape unit by the Manual Status line.

Reels supply tape to and remove tape from the vacuum columns under control of the vacuum column switches. The vacuum column switches sense the tape position and initiate corrective reel motion. The capstan moves the tape which causes reel motion.

### REEL MOTORS AND DRIVERS

The reel motors run at three different speeds. Changing the armature and field voltages varies motor speed.

Speed	Voltages	Function
Low	Armature -12 volts Field -45 volts	Manual operations: Load, Thread, Unload.
Normal	Armature -45 volts Field -45 volts	Read, write, slow speed rewind.
High	Armature -45 volts Field -6 volts	High speed rewind

Motor direction is determined by the direction (polarity) of armature current.

In either direction and at any speed, the reel motors can be in proportional drive, proportional coast, or brake status. A motor is in proportional drive status when current is passing through the armature. A motor is in proportional coast status when no current is passing through the armature. A motor is in brake status when the armature is short-circuited (both sides of the armature grounded).

### REEL STABILIZATION

Column vacuum tends to pull the tape loop toward the bottom of the straight columns when the tape unit is loaded and stopped. To overcome this force, -12 volts (reel anti-bobble voltage) is applied to each reel motor armature to produce an opposing torque.

3803-1,2,3/3420

<b>XB1900</b> Seq 1 of 2	<b>2735762</b> Part Number	<b>See EC</b> <b>History</b>	<b>845958</b> 1 Sep 79	<b>847298</b> 15 Aug 83				
-----------------------------	-------------------------------	---------------------------------	---------------------------	----------------------------	--	--	--	--

© Copyright International Business Machines Corporation 1976, 1979, 1983

3A-020

# REEL AND CAPSTAN OPERATIONS DURING REWIND

The tape unit rewinds at two speeds, normal read/write (slow) speed and high speed.

The Model 3 slow speed rewinds at 120 inches (304,8 cm) per second instead of the normal read/write speed of 75 inches (190,5 cm) per second.

During normal rewind, the capstan control circuit controls capstan speed.

During high speed rewind, the reel/capstan comparison circuits control capstan speed. These circuits compare the outputs of the reel tachometers to the output of the 16 count generator, which supplies a pulse for every 16 capstan pulses when tape is moving at the same speed as the capstan and reel tachs.

Switching the capstan motor between high power drive and coast status controls capstan speed. To maintain optimum rewind speed while preventing tape from pulling out of, or bottoming in, the columns, additional circuits drive or coast the capstan for short periods of time. These circuits, called proportional drive and proportional coast are controlled by singleshot circuits.

## REEL TACHOMETERS

The right and left reel tachs are phototransistors in the idlers above each vacuum column. Reel squaring circuits square the tach pulses, and the resulting pulses are compared to the capstan tach pulses by the 16 count generator and the reel/capstan comparison circuits.

During high speed rewind, the reel tachs and reel/capstan comparison circuits supply information for the reel motor control, in addition to controlling capstan motor speed.

The Reel Fast latch either drives the capstan or lets it coast, depending upon the position of tape in the columns. If the right and left circuits make different demands at the same time, Coast overrides Drive.

Capstan Motor Status Relative To Position Of Tape In Columns

Loop Motion	Left Column		Right Column		Loop Motion		
	Up	Down	Up	Down			
Vacuum	L 1	C	PD	D	R 1	Vacuum	
Column	L 2	PC	D	D	R 3	Column	
Ports	L 3	D	D	PD	C	R 3	Ports
	L 4	D	D	PD	C	R 4	

**Abbreviations:**

- C = Coast
- D = Drive
- PC = Prop Coast
- PD = Prop Drive

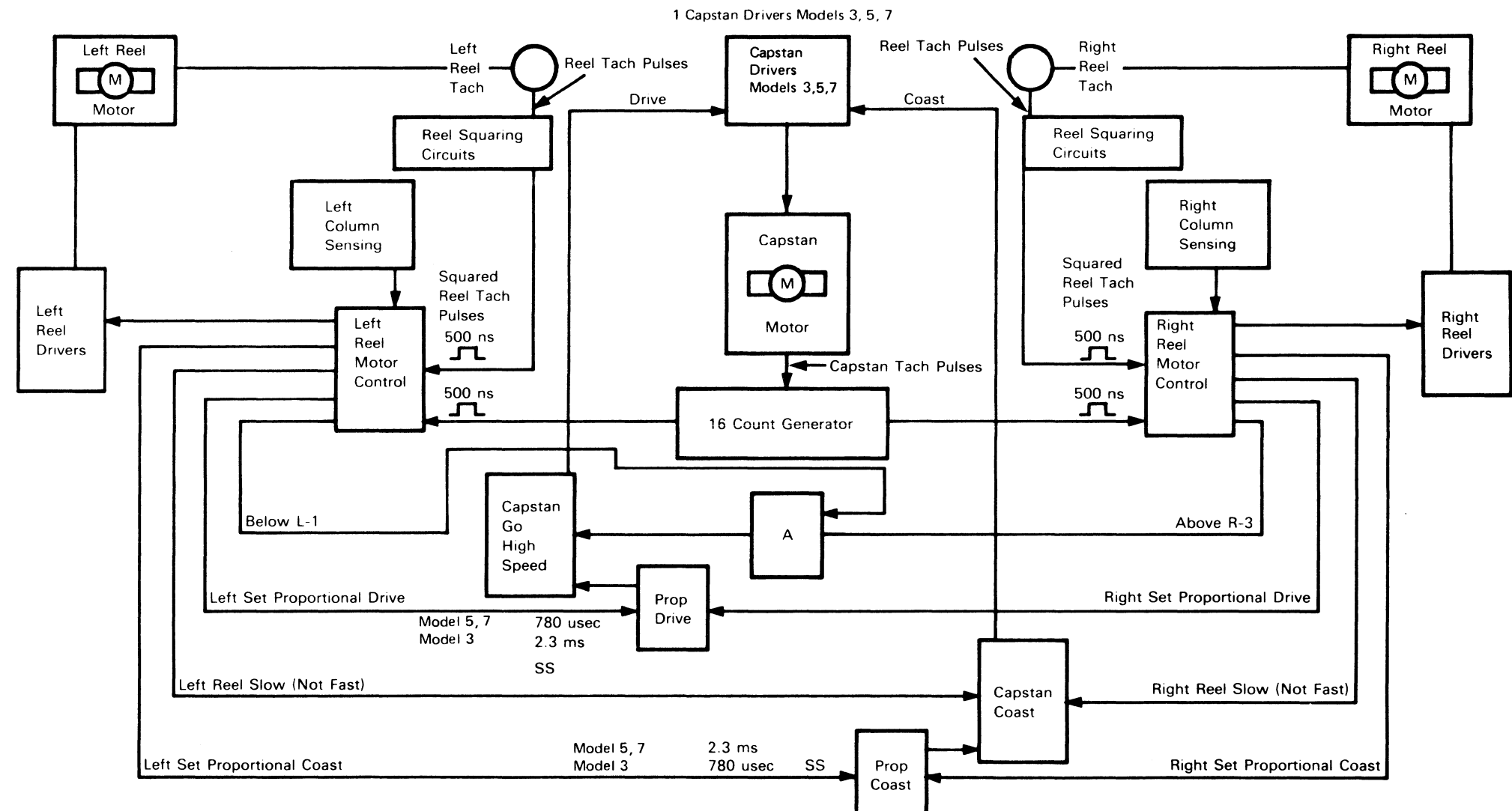

3803-1,2,3/3420

<b>XB1900</b> Seq 2 of 2	<b>2735762</b> Part Number	<b>See EC History</b>	<b>845958</b> 1 Sep 79	<b>847298</b> 15 Aug 83					
-----------------------------	-------------------------------	-----------------------	---------------------------	----------------------------	--	--	--	--	--

# NO RESPONSE OR TAPE MOVES BACKWARD

The field tester activates Move and Forward Status to move tape forward. Sensing the end-of-tape (EOT) marker causes the field tester to drop the Move tag.

If tape goes backward until it is pulled off the end of the reel, turn power off the tape unit and unplug the capstan motor, then turn power on and reload the tape.

If tape unit will not load at mid-tape, unplug the capstan motor before attempting a normal load. Catch reels before tape bottoms and secure tape in place below L2 and above R2 vacuum ports.

### SET UP:

1. Install field tester.
2. Set up tester for Forward, St/Stp in the failing mode (read or write).

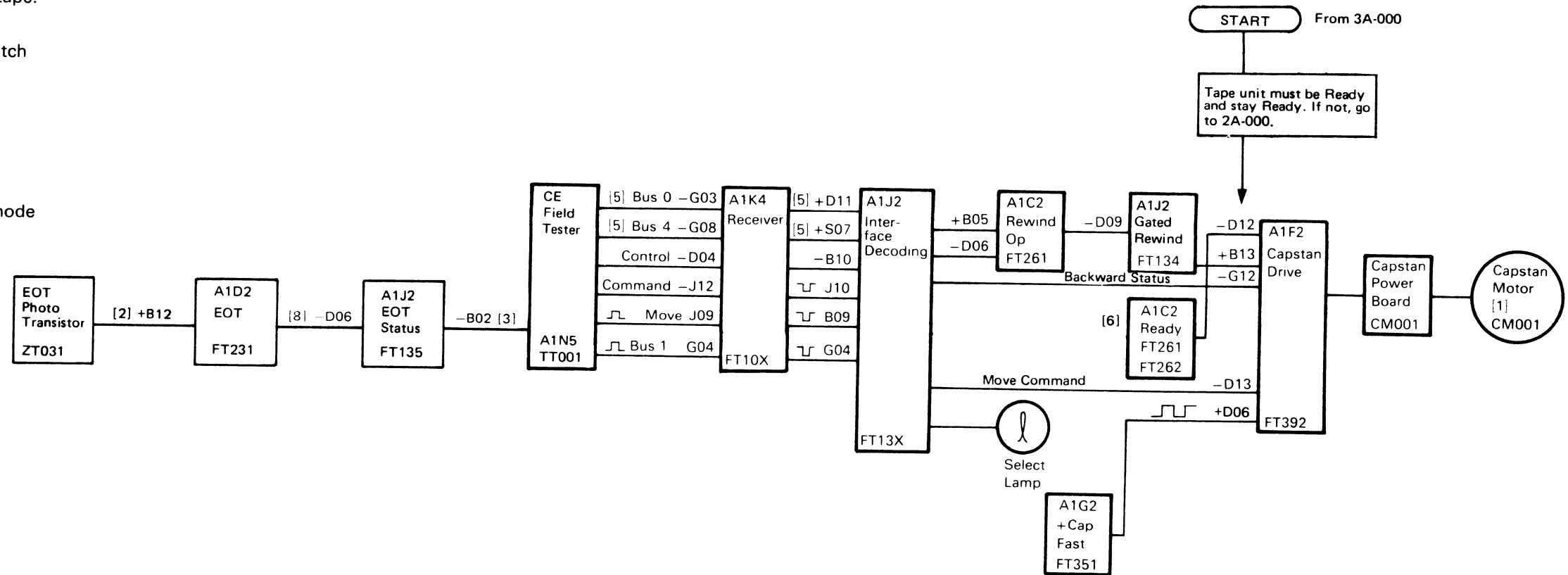

### Notes:

- + Indicates nominal MST-1 plus (up) level of -0.85 Vdc; line should have solid up level or go to the up level.
- Indicates nominal MST-1 minus (down) level of -1.85 Vdc; line should have solid down level or go to the down level.
- [1] Replace per "Capstan Assembly Replacement" See 08-000.
- [2] Typical voltage: +1.6 Vdc dark and less than +1.5 VDC light.
- [3] Special voltage: +6 Vdc to 0 Vdc.
- [4] Special voltage: +4 Vdc to 0 Vdc.
- [5] If doing a write operation, this line will be pulsing.
- [6] If problem is not fixed, go to 2A-000.
- [8] If the level is incorrect, do the BOT/EOT adjustment on 08-580 before checking the T-A1D2 input.

3803-1,2,3/3420

XB2000 Seq 1 of 2	2735763 Part Number	See EC History	845958 1 Sep 79	847298 15 Aug 83			
----------------------	------------------------	-------------------	--------------------	---------------------	--	--	--

# LEFT OR RIGHT VACUUM COLUMN

## SYMPTOM:

Tape bobbles, bottoms in, or pulls out of columns.

Ensure that vacuum column door is not leaking. (See 08-680).

Be certain that the tape reel does not slip on the right reel hub. If it does slip, suspect a leaking diaphragm or seal on the right reel hub.

In order for the reel motor to keep up with the capstan motor, 48 volts is applied to both reel power boards, by resetting Manual Status (ALD FT265) with Load Complete. The capstan should be running at a controlled speed (75 ips for Mod 3, 125 ips for Mod 5, and 200 ips for Mod 7).

## SET UP:

1. Fasten a short strip of magnetic tape in each vacuum column so it forms a loop halfway down each column as follows:

Anchor one end of each tape strip at its respective stubby column. Then route the tape halfway down and back out of the column by looping over the reel tachs. Anchor these ends with transparent or masking tape. Cut the tape over-all length to allow for later adjustment to the bottom of the vacuum column. (See 08-450 for an illustration of this procedure).

Block the BOT/EOT with a piece of card. Cover the reels loaded port with a piece of transparent or masking tape.

2. **Caution:**  
**Do not let tape touch the capstan under any circumstance, or the capstan may be severely damaged.**
3. Press RESET, LOAD REWIND, and START again. The Ready light should not come on.  
Press RESET, and START. The Ready lamp should come on because this is a mid-tape load.
4. Leave the field tester in Forward and Go.

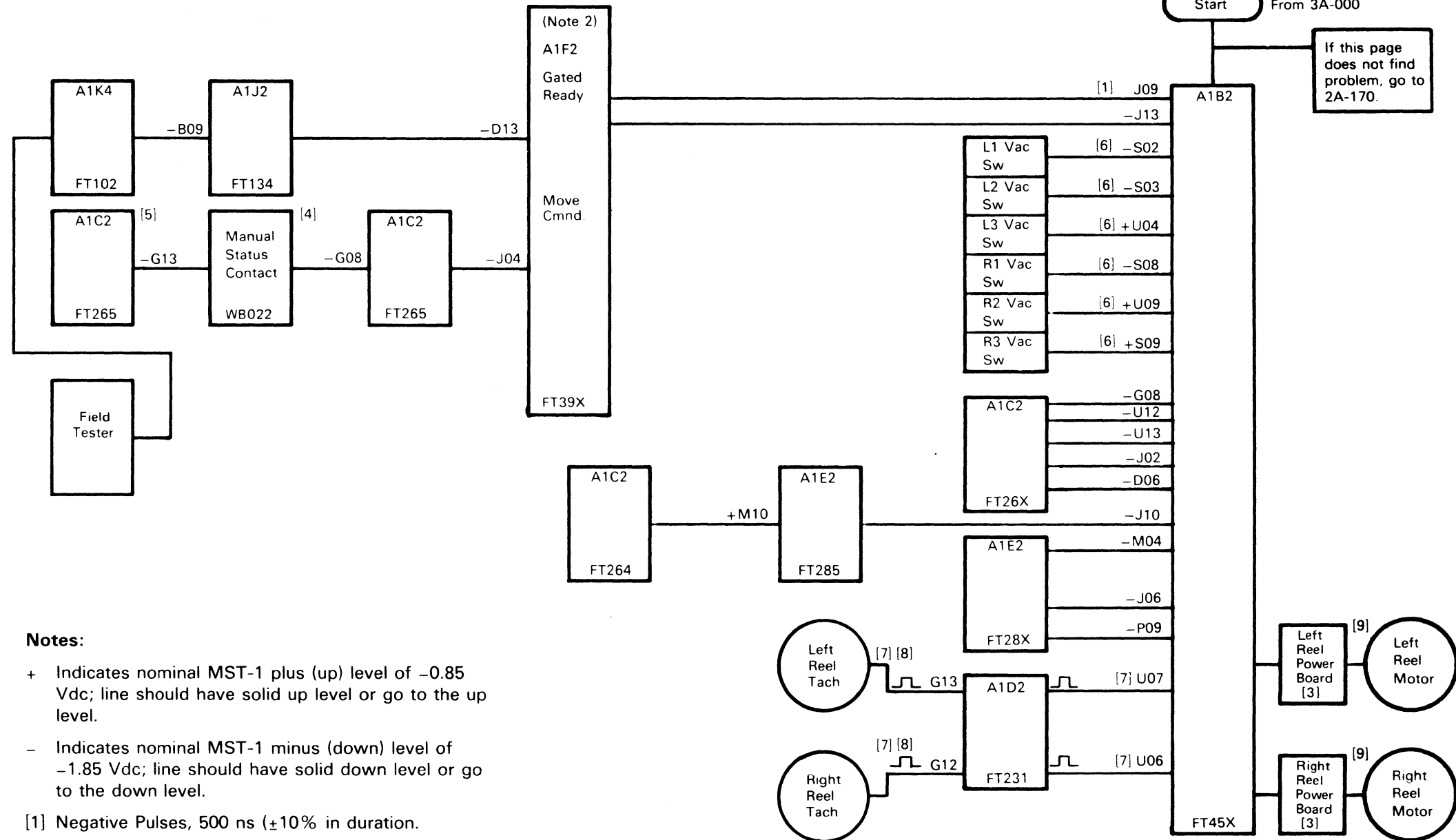

### Notes:

- + Indicates nominal MST-1 plus (up) level of  $-0.85$  Vdc; line should have solid up level or go to the up level.
- Indicates nominal MST-1 minus (down) level of  $-1.85$  Vdc; line should have solid down level or go to the down level.
- [1] Negative Pulses, 500 ns ( $\pm 10\%$  in duration).  
0.98 ms period for Model 3.  
0.90 ms period for Model 5.  
0.75 ms period for Model 7.  
If period varies more than 5% from nominal, go to 6A-000.
- [2] Change T-A1F2 and T-A1G2. Go to 6A-000 to determine failing FRU.
- [3] Reel power boards may be exchanged between tape units if the reel power board part numbers are identical.

[4] Special voltage:  $-0.5$  Vdc to  $-2.5$  Vdc.

[5] Special voltage:  $+12$  Vdc to  $0$  Vdc.

[6] Levels shown for test set up. For intermittent problems, manually pass tape across the switch ports to check switch operation (+ above - below). Positioning the tape loop in the middle of the port may cause the vacuum switch to oscillate. Using internal sync, check the condition of the switch contacts. Special voltage:  $0$  Vdc to  $-4$  Vdc.

[7] Manually rotate the reel tachs by pulling on the magnetic tape strips.

[8] Special voltage:  $+1.7$  Vdc to  $.6$  Vdc.

[9] Check the  $-48$  Vdc at lower heat sink screws of the power transistors on the power boards. Position loop to place tape above L1 or R1 ports.

3803-1.2.3/3420

XB2000	2735763	See EC	845958	847298				
Seq 2 of 2	Part Number	History	1 Sep 79	15 Aug 83				

© Copyright International Business Machines Corporation 1976, 1979, 1983

# TAPE FAILS TO GO BACKWARD

A Backward command from the field tester generates Backward Status, which moves the tape back to load point.

The field tester sets Backward Status and activates the Move tag. These lines are decoded in the tape unit bus out circuits to develop the go backward operation.

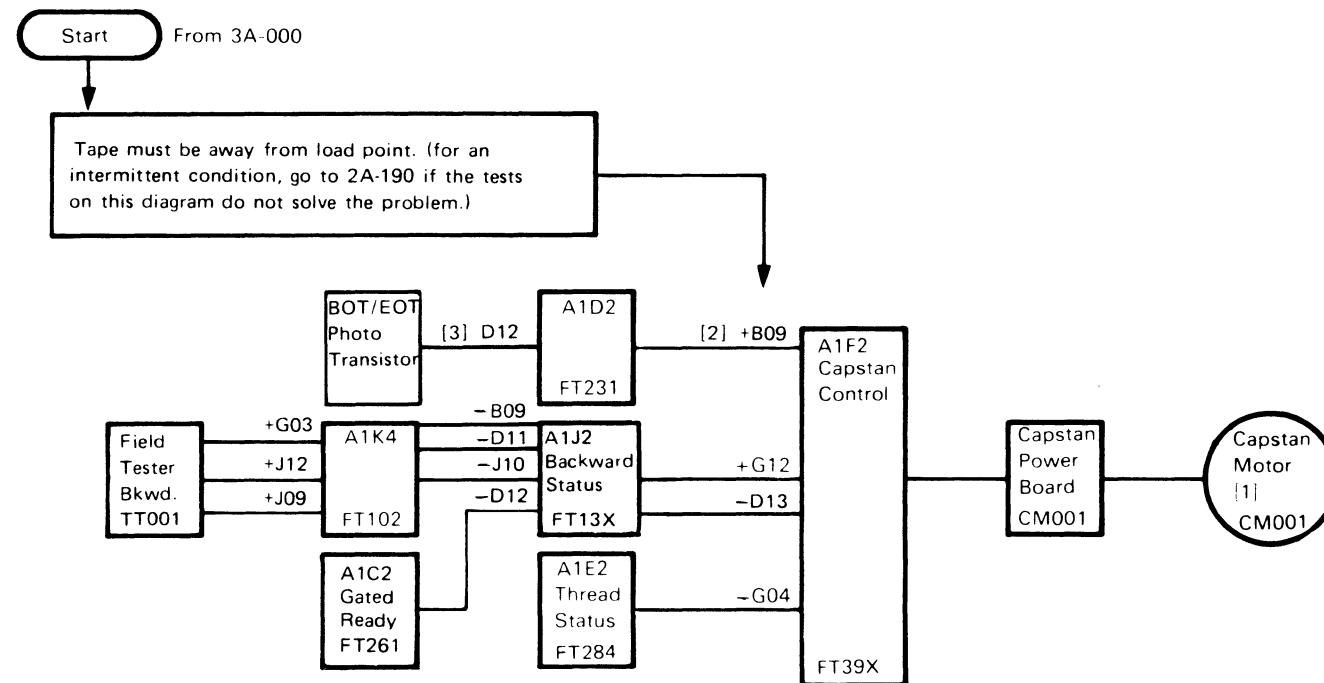

**Notes:**

- + Indicates nominal MST-1 plus (up) level of -0.85 Vdc; line should have solid up level or go to the up level.
- Indicates nominal MST-1 minus (down) level of -1.85 Vdc; line should have solid down level or go to the down level.
- [1] Replace per "Capstan Assembly Replacement". See 08-000.
- [2] If the level is incorrect, perform the BOT/EOT adjustments before checking the T-A1D2 inputs. (See 08-580).
- [3] Typical voltage level is +1.6 Vdc dark and less than +1.5 Vdc light.

3803-1,2,3/3420

<b>XB2100</b> Seq 1 of 2	<b>2735764</b> Part Number	<b>See EC History</b>	<b>845958</b> 1 Sep 79	<b>847298</b> 15 Aug 83				
-----------------------------	-------------------------------	-----------------------	---------------------------	----------------------------	--	--	--	--

# TAPE DOES NOT STOP OR TAPE RUNAWAY (FORWARD OR BACKWARD)

Setting the field tester to Stop, deactivates the Move tag, and stops tape motion forward or backward.

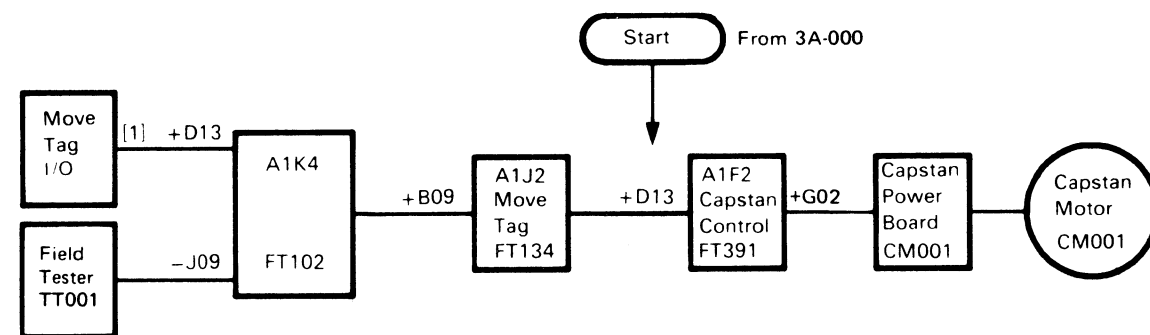

**Notes:**

- + Indicates nominal MST-1 plus (up) level of -0.85 Vdc; line should have solid up level or go to the up level.
  - Indicates nominal MST-1 minus (down) level of -1.85 Vdc; line should have solid down level or go to the down level.
- [1] Plus (up) level is +4.4 Vdc and minus (down) level is +0 Vdc.

3803-1,2,3/3420

<b>XB2100</b>	<b>2735764</b>	<b>See EC History</b>	<b>845958</b>	<b>847298</b>				
Seq 2 of 2	Part Number		1 Sep 79	15 Aug 83				

© Copyright International Business Machines Corporation 1976, 1979, 1983

# TAPE UNWINDS OFF RIGHT REEL

3A-150

When the end-of-tape (EOT) marker is sensed, Tape Indicate (TI) is set (ALD FT135). The EOT circuitry causes the Move tag in the field tester to be reset. The tester deactivates the Move tag and stops the tape with the TI indicator on. Press Reset and Load Rewind on the tester, and tape begins to rewind. The TI marker, sensed while tape is moving in a backward direction, resets the Tape Indicate latch and turns off the indicator.

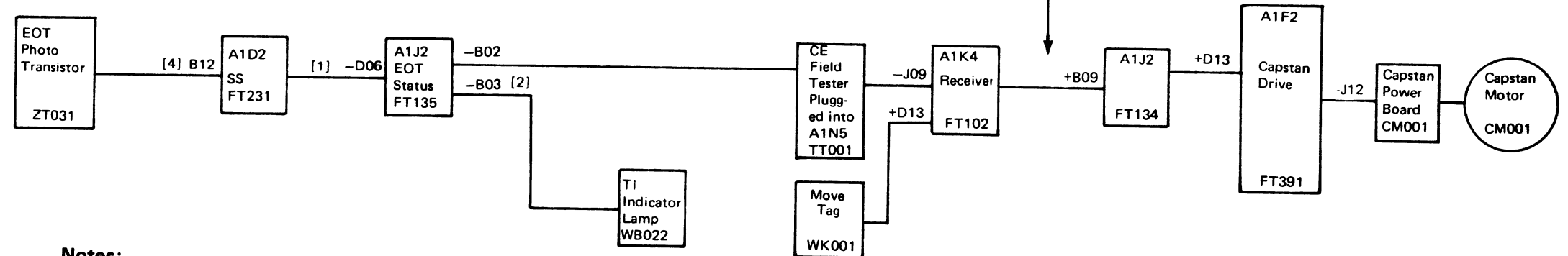
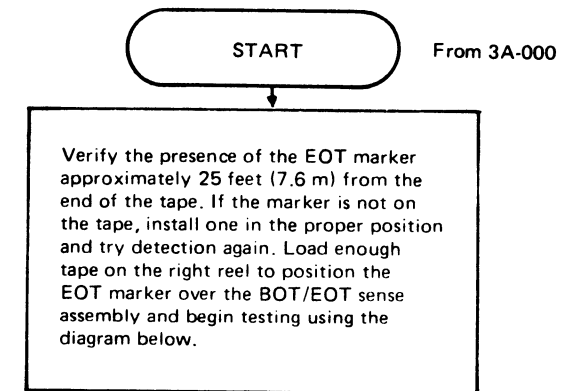

**Notes:**

- + Indicates nominal MST-1 plus (up) level of -0.85 Vdc; line should have solid up level or go to the up level.
- Indicates nominal MST-1 minus (down) level of -1.85 Vdc; line should have solid down level or go to the down level.

[1] A positive pulse is generated when the EOT marker passes the sensor. If the line level is incorrect, remove the tape. Perform the BOT/EOT adjustment before checking the T-A1D2 input. (See 08-580 for the BOT/EOT adjustment procedure).

[2] Plus (up) level is +12 Vdc and minus (down) level is 0 Vdc. T-A1J2B03 should be at 0 Vdc when the tape unit is stopped at EOT; +12 Vdc after rewind starts.

[4] Special voltage levels: +1.6 Vdc dark and less than +1.5 Vdc light.

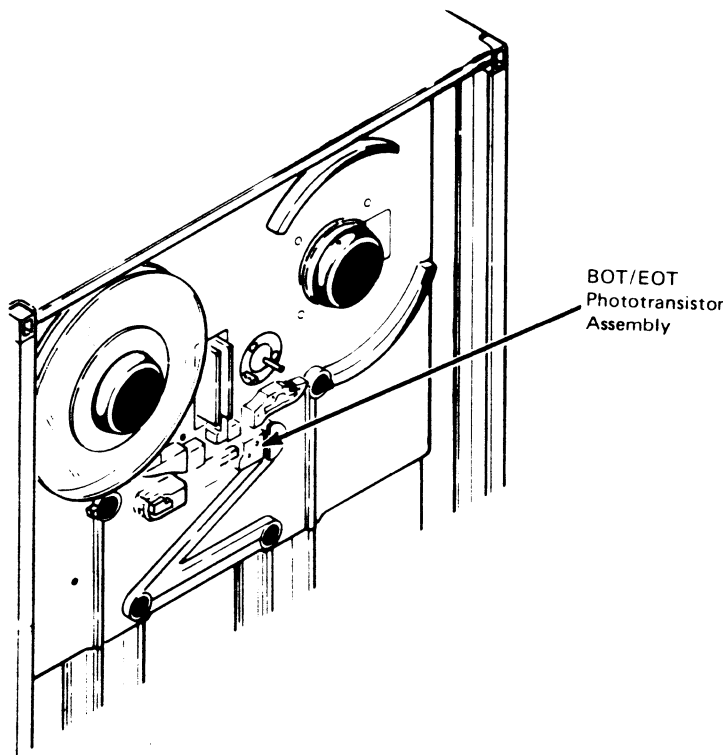

3803-1.2,3/3420

<b>XB2200</b>	<b>2735765</b>	<b>See EC History</b>	<b>845958</b>	<b>847298</b>			
Seq 1 of 2	Part Number		1 Sep 79	15 Aug 83			

© Copyright International Business Machines Corporation 1976, 1979, 1983

3A-150

**TAPE PULLS OUT, DUMPS OR HAS WIDE EXCURSIONS IN LEFT COLUMN DURING HIGH SPEED REWIND.**

When high speed rewind is initiated, the reel tachometers must sense that both reels are turning at normal operating speed before high speed rewinding begins. Tape motion starts with the capstan at low speed and the reel motors in high power drive status. High Speed Field (ALD FT45X) reduces the reel motor field voltage to six volts, which allows the reel motors to turn faster. The capstan accelerates to 600-800 ips in less time than the reels, due to the greater inertia of the reels. Tape then rises above the L1 port or drops below the R3 port, which activates Capstan Coast (ALD FT455) to slow the capstan. When the tape reels reach their maximum speed, the capstan speed stabilizes between 600 and 800 ips.

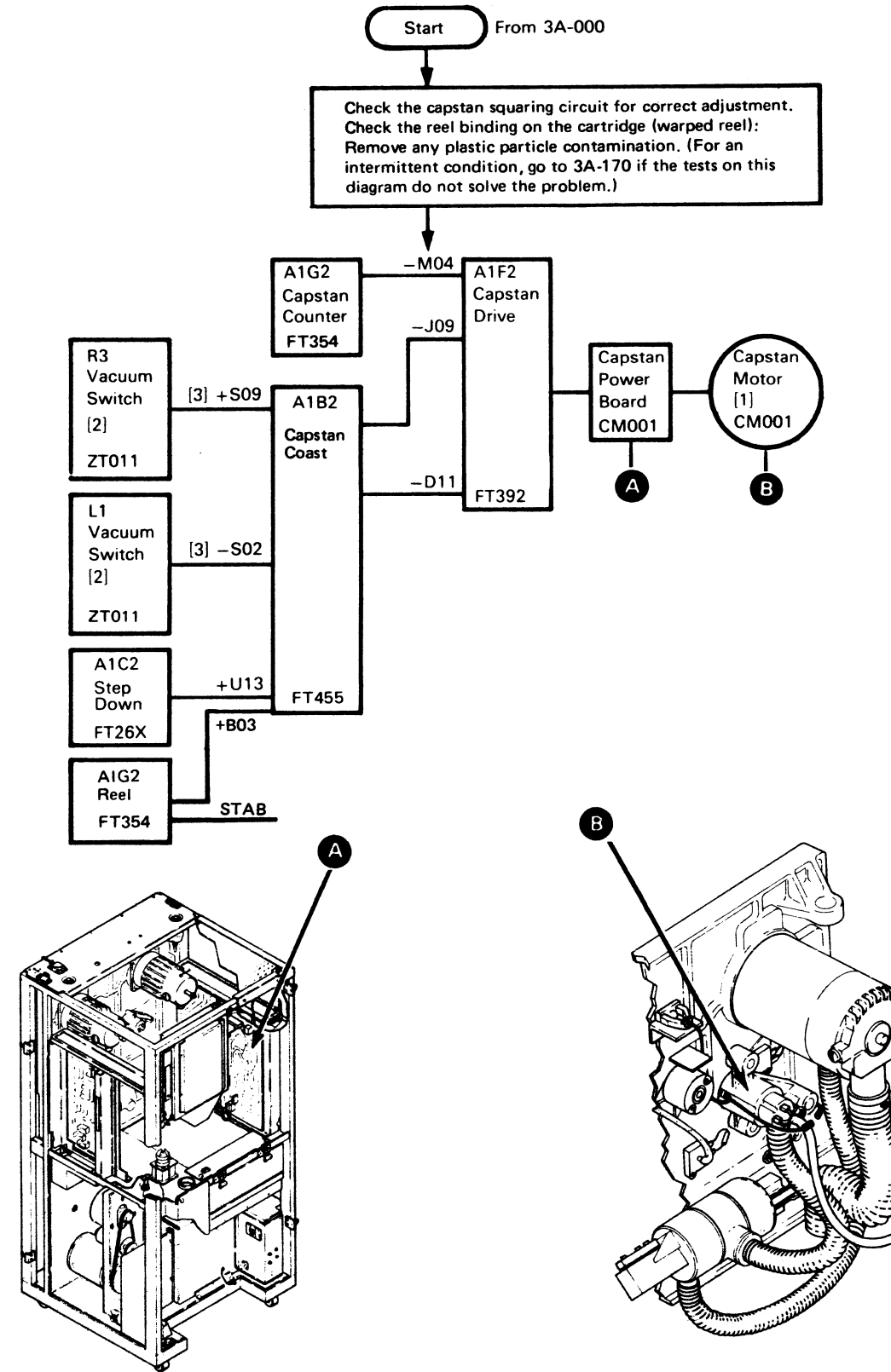

**Notes:**

- + Indicates nominal MST-1 plus (up) level of -0.85 Vdc; line should have solid up level or go to the up level.
- Indicates nominal MST-1 minus (down) level of -1.85 Vdc; line should have solid down level or go to the down level.
- [1] Replace per "Capstan Assembly Replacement". (See 08-000).
- [2] Check per "Vacuum Column Switch Check". (See 08-450).
- [3] Plus (up) level is 0 Vdc and minus (down) level is -4 Vdc.

3803-1,2,3/3420

<b>XB2200</b> Seq 2 of 2	<b>2735765</b> Part Number	<b>See EC</b> History	<b>845958</b> 1 Sep 79	<b>847298</b> 15 Aug 83				
-----------------------------	-------------------------------	--------------------------	---------------------------	----------------------------	--	--	--	--

© Copyright International Business Machines Corporation 1976, 1979, 1983



# TAPE DOES NOT ENTER OR STAY IN HIGH SPEED REWIND OR REWINDS TO BEGINNING-OF-TAPE (BOT) AT HIGH SPEED

Tape does not enter high speed rewind or does not stay in high speed rewind.

Tape rewinds at high speed until the reflective marker on the left reel becomes visible. Light reflected from this marker generates a High Speed Reset Pulse, which resets the HS Rewind Status latch (ALD FT262). Check the reel tachometers to make sure they are free from binds. Reel tachometers must indicate that tape is running at normal speed before tape is accelerated to high speed rewind.

Tape rewinds at high speed until the reflective marker is exposed. The marker reflects light from the left reel light source to the radius sense photocell. Pulses from the radius sense phototransistor develop a high speed reset pulse which resets the Rewind Status latch (ALD FT262). The reel motor field voltages are changed back to 48 Vdc for the low speed rewind operation.

Use entry Start A if tape does not enter high speed rewind or will not stay in high speed rewind. Use entry Start B if tape rewinds to BOT at high speed.

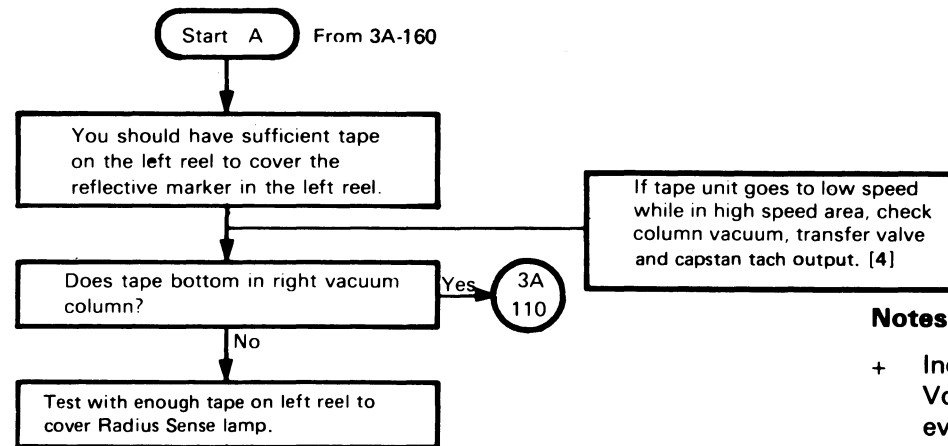

**Notes:**

- + Indicates nominal MST-1 plus (up) level of -0.85 Vdc; line should have solid up level or go to the up evel.
- Indicates nominal MST-1 minus (down) level of -1.85 Vdc; line should have solid down level or go to the down level.
- [1] Plus level is 0 Vdc and minus level is -4 Vdc.
- [2] With vacuum, plus level is with tape above and minus level is with tape below.
- [3] Replace per "Capstan Assembly Replacement". (See 08-000).
- [4] Compare both right and left reel tachometer outputs during high speed rewind; both should have plus pulses with approximately the same duration and frequency. If there is no output, suspect the photocell or fiber optics. If either output has longer positive pulses or less frequency, suspect a binding or slipping tach.
- [5] Reel tach subassemblies (less optic bundle) are available for field replacement as follows:  
 Left subassembly  
 Right subassembly  
 Photocell cable Photocell subassemblies are not available. Complete assembly must be replaced.
- [6] Minus pulses should be present during high speed rewind.
- [7] If the radius sense does not pulse in the low speed area, clean the ends of the fiber optic bundle with a damp cloth (see 08-610 for removal). Also, apply a felt pad to the handle and lightly dampen with tape cleaning fluid. Hold the pad to the inside front of the left reel and spin the reel by hand. This cleans the reflective strips located on the inside front of the left reel flange.

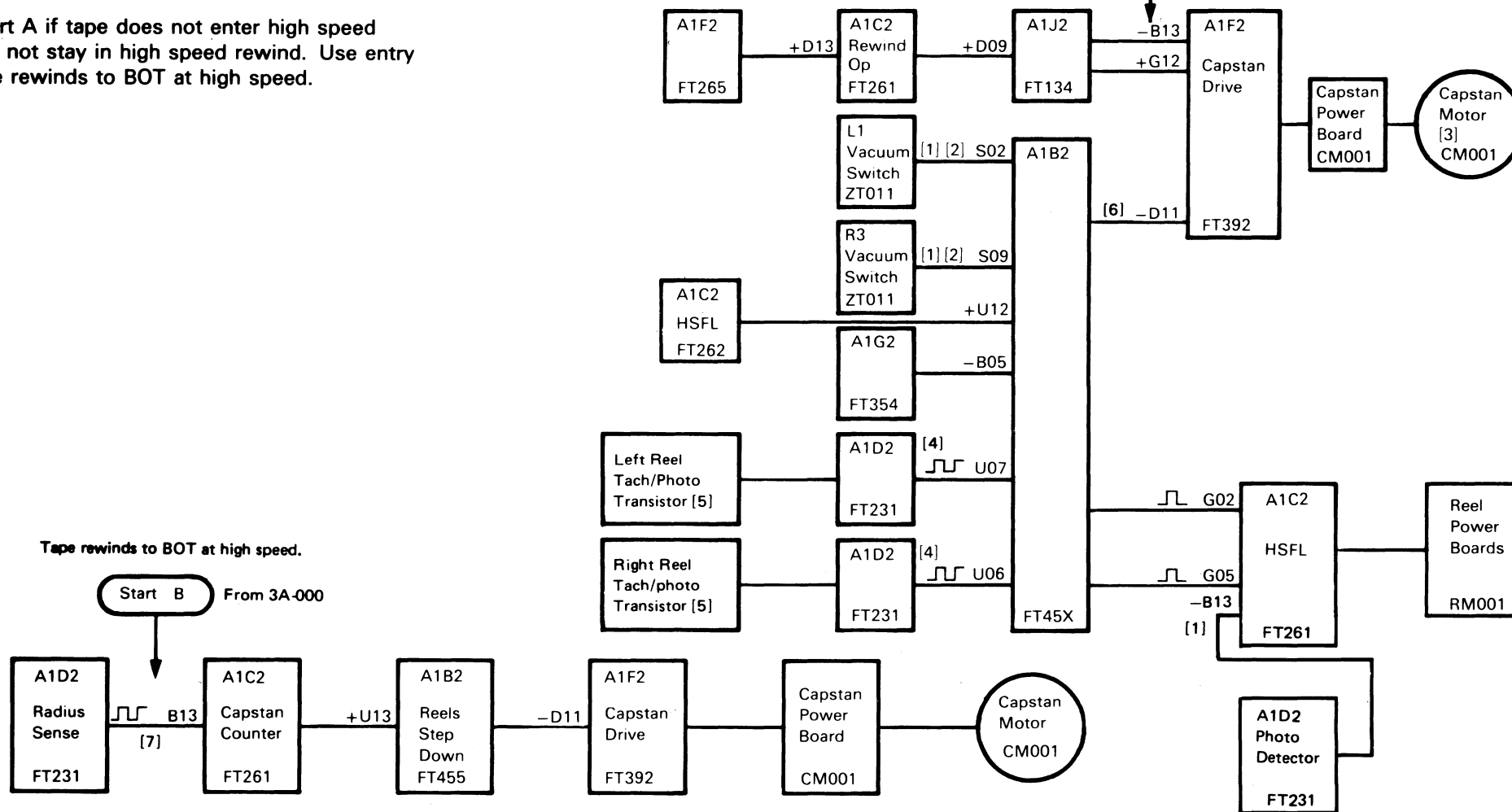

Tape rewinds to BOT at high speed.

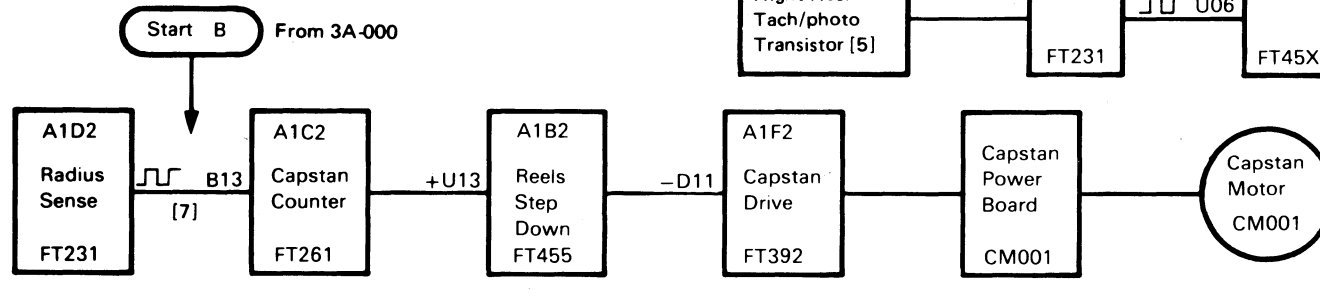

3803-1,2,3/3420

XB2300	2735786	See EC	845958				
Seq 1 of 2	Part Number	History	1 Sep 79				

NOTES:

3A-171

3803-1,2,3/3420

<b>XB2300</b> Seq 2 of 2	<b>2735766</b> Part Number	<b>See EC</b> <b>History</b>	<b>845958</b> 1 Sep 79						
-----------------------------	-------------------------------	---------------------------------	---------------------------	--	--	--	--	--	--

© Copyright International Business Machines Corporation 1976, 1979

3A-171

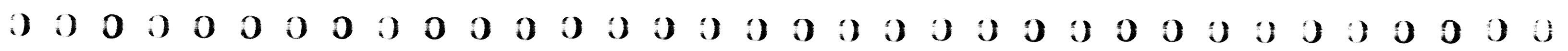

## UNLOAD SYMPTOMS

4A-000

This MAP assumes that the tape unit loads correctly.

### UNLOAD OPERATION WITH CARTRIDGE AND WITHOUT EC 734952

An unload operation is started by pressing RESET and UNLOAD REWIND. If the tape is not at beginning-of-tape (BOT), it is rewound to BOT before it is unloaded.

Pressing UNLOAD REWIND activates Manual Status, Rewind Unload Status, and Unload Operation. Unload Op and Manual Status cause the right reel to turn counterclockwise, pulling the tape out of the columns. When the tape goes above the L1 vacuum port, the transfer valve solenoid is energized. The transfer valve shuts off air and vacuum to the air bearings and columns. At the same time, the right reel stops and the left reel turns clockwise. The left reel pulls the remaining tape out of the columns until the Reels Loaded switch is transferred. Columns Unloaded is activated by vacuum column switches R4 and L4 being deactivated.

When the Reels Loaded switch is transferred, both reels turn counterclockwise until all the tape is on the right reel. Tape Present is deactivated when the end of the tape leader passes the BOT/EOT phototransistors. Unload Complete is activated by Columns Unloaded and not Tape Present.

Unload Complete causes the cartridge to close and the pneumatic supply to turn off.

### UNLOAD OPERATION WITHOUT CARTRIDGE

The unload operation without a cartridge is the same as with a cartridge except that the cartridge motor doesn't operate.

### UNLOAD OPERATION WITH CARTRIDGE AND EC 734952

An unload operation is started by pressing RESET and UNLOAD REWIND. If the tape is not at the beginning-of-tape (BOT) marker, it is rewound to BOT before it is unloaded.

Pressing UNLOAD REWIND activates Manual Status, Rewind Unload Status, and Unload Operation. Unload Operation and Manual Status cause the right reel to turn counterclockwise, pulling the tape out of the right column. When the tape is pulled above R1, pneumatics drop and the transfer valve solenoid is energized. Pneumatics turn on again, but the transfer valve shuts off air and vacuum to the air bearings and columns. At the same time, the right reel stops and the left reel turns clockwise. The left reel pulls the remaining tape out of the columns until the Reels Loaded switch is transferred. Columns Unloaded is activated when vacuum column switches R4 and L4 transfer.

When the Reels Loaded switch is transferred, pneumatics drop, and both reels turn counterclockwise until all the tape is on the right reel. Not Tape Present is activated when the end of the tape leader passes the BOT/EOT phototransistors. Unload Complete is activated by Columns Unloaded and not Tape Present.

Unload Complete causes the cartridge to close.

### UNLOAD OPERATION WITHOUT CARTRIDGE

The unload operation without a cartridge is the same as with a cartridge except that the cartridge motor does not operate.

#### 4A-000: UNLOAD SYMPTOMS

From 00-040, START 2

#### Possible Causes:

- BOT/EOT mirror is dirty.
- BOT/EOT adjustments.
- Transfer valve leaking. See 08-400.
- T-A1C2, T-A1E2 defective.

Always start with Seq 1 and follow the procedure in sequence unless directed otherwise. Remember to END all problem or maintenance calls by going to MAP 00-030.

Seq	Condition/Instruction	Action
1	Does the tape unit unload by using the UNLOAD REWIND pushbutton, but not by using the field tester or tape control unit commands?	Replace: T-A1K4 T-A1J2  If not fixed, go to ALD FT134 and isolate to the failing point.
1A	Be sure the tape unit is loaded, at load point, and ready.	
2	Press RESET. Does the Ready indicator turn off?	Go to Seq 4.
3	If not:	Go to 4A-100.
4	Press the UNLOAD REWIND pushbutton. Does the right reel turn counterclockwise?	Go to Seq 6.
5	If not:	Go to 4A-110.
6	Does tape come out of both columns properly?	Go to Seq 7A.
7	If not:	Go to 4A-120.
7A	If EC 734952 is installed, does pneumatic motor fail to turn off? If EC 734952 is not installed, go to Seq 8.	Go to 4A-160.
8	Does tape wind completely onto right reel?	Go to Seq 10.
9	If not:	Go to 4A-130.
10	Do both reels stop?	If EC 734952 is not installed, go to Seq 12. With EC 734952 installed, go to Seq 14.
11	If not:	Clean the EOT/BOT mirror. Check BOT/EOT adjustments. Adjust if necessary. See 08-000. Go to 4A-130.
12	Does the pneumatic motor turn off?	Go to Seq 14.
13	If not:	Go to 4A-160.
14	Is a cartridge in use?	Go to Seq 17.
15	Does power window go down?	Recheck symptoms.
16	If not:	Go to 4A-140.
17	Does cartridge close?	Go to Seq 15.
18	If not:	Go to 4A-150.

3803-1.2,3/3420

XB2400 Seq 1 of 2	2735767 Part Number	See EC History	845958 1 Sep 79	847298 15 Aug 83				
----------------------	------------------------	-------------------	--------------------	---------------------	--	--	--	--

© Copyright International Business Machines Corporation 1976, 1979, 1983

4A-000

# READY LAMP DOES NOT TURN OFF

Pressing the RESET pushbutton resets Ready Status, which turns off the Ready latch (ALD FT262) and the Ready indicator.

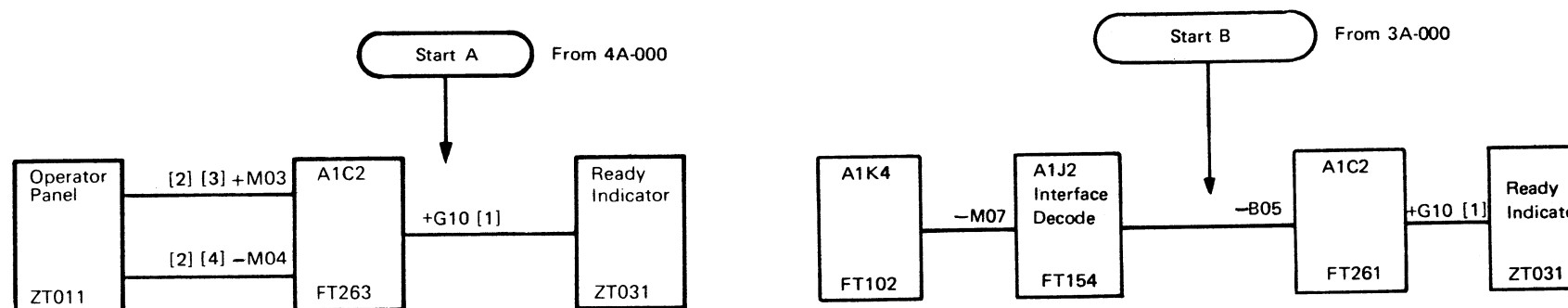

**Notes:**

- + Indicates nominal MST-1 plus (up) level of -0.85 Vdc; line should have solid up level or go to the up level
- Indicates nominal MST-1 minus (down) level of -1.85 Vdc; line should have solid down level or go to the down level.
- [1] Plus (up) level is +12 Vdc and minus (down) level is 0 Vdc.
- [2] Plus (up) level is 0 Vdc and minus (down) level is -4 Vdc.
- [3] When the RESET pushbutton is pressed, the voltage level is 0 Vdc.
- [4] Level is -4 Vdc unless the START pushbutton is pressed.

3803-1,2,3/3420

X82400	2735767	See EC History	845958	847298				
Seq 2 of 2	Part Number		1 Sep 79	15 Aug 83				

© Copyright International Business Machines Corporation 1976, 1979, 1983

# UNLOAD REWIND PUSHBUTTON (NO RESPONSE)

The UNLOAD REWIND pushbutton sets Unload Operation (ALD FT265), Unload Rewind, and Manual Status. The right reel turns counterclockwise, pulling tape out of the right column.

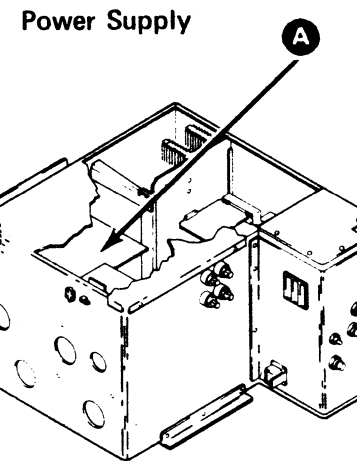
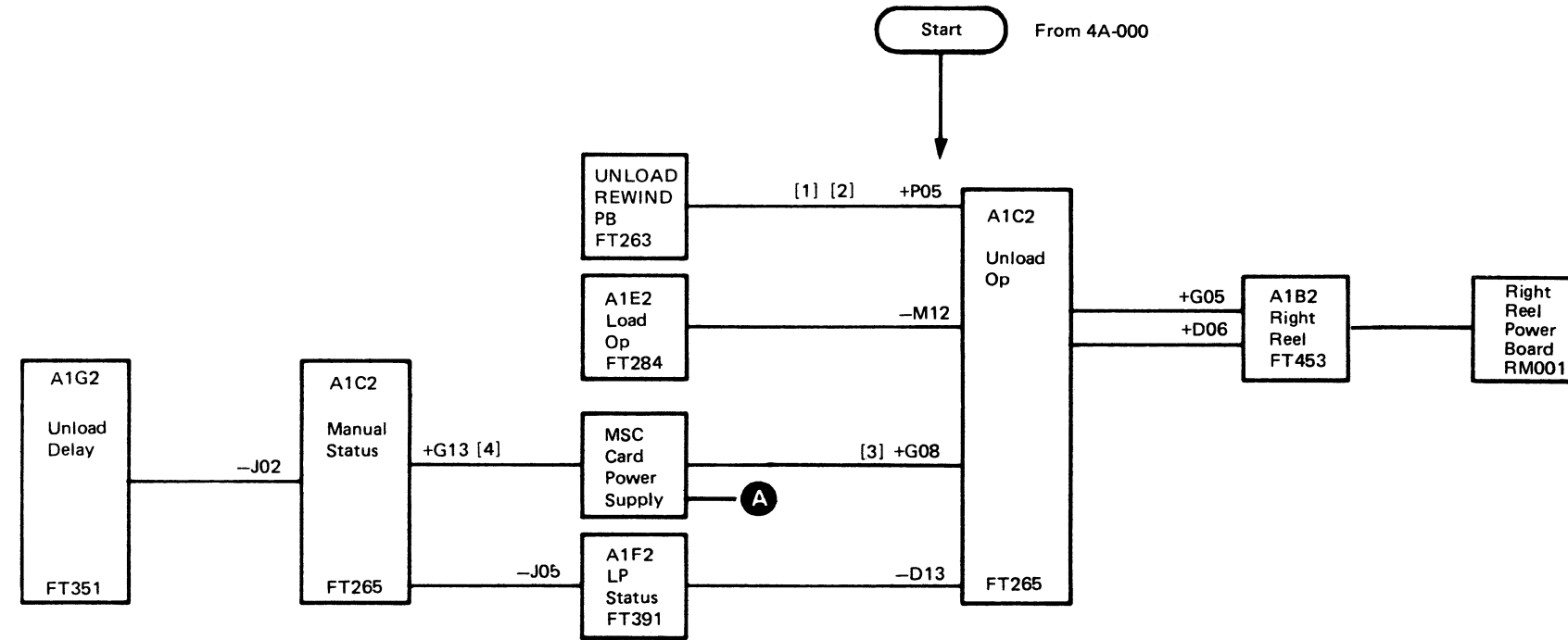

**Notes:**

- + Indicates nominal MST-1 plus (up) level of -0.85 Vdc; line should have solid up level or go to the up level.
- Indicates nominal MST-1 minus (down) level of -1.85 Vdc; line should have solid down level or go to the down level.
- [1] Plus (up) level is 0 Vdc and minus (down) level is -4 Vdc.
- [2] Level is 0 Vdc with UNLOAD REWIND pushbutton pressed.
- [3] Special voltage: -5 Vdc to -2.5 Vdc.
- [4] Plus (up) level is +12 Vdc and minus (down) level is 0 Vdc.

3803-1.2,3/3420

<b>XB2500</b> Seq 1 of 2	<b>2735768</b> Part Number	<b>See EC History</b>	<b>845958</b> 1 Sep 79	<b>847298</b> 15 Aug 83				
-----------------------------	-------------------------------	-----------------------	---------------------------	----------------------------	--	--	--	--

**TAPE DOES NOT PULL OUT OF COLUMNS PROPERLY DURING UNLOAD REWIND**

**WITHOUT EC 734952 (ALD FT283)**

Unload starts the right reel turning counterclockwise pulling all of the tape out of the right column and then the left column until the tape loop rises above vacuum switch L1. At this time, the transfer valve is picked (ALD FT283). Vacuum is removed from the columns resulting in Columns Unloaded status which signals the right reel to stop and the left reel to take up tape by turning clockwise (ALD FT283). This continues until Reels Loaded is sensed. This causes both reels to turn counterclockwise until all of the tape is on the right reel.

**Caution: If the right reel does not stop, tape damage may result.**

- [4] If T-A1B2 and the reel board have been replaced, and the trouble still exists, refer to OPER section for theory.
- [5] See 08-400 for transfer valve leakage test.
- [6] Line is minus until tape is out of the right column. Then the line goes plus until tape is out of the left column.

**WITH EC 734952 (ALD FT283)**

Unload starts the right reel turning counterclockwise, pulling tape out of the right column. As vacuum switch R1 transfers, vacuum drops as pneumatics drop, L4 and R4 vacuum switches transfer. When L4 and R4 transfer, this signals Columns Unloaded status which:

1. Activates the transfer valve.
2. Activates the pneumatics motor.
3. Stops the right reel motor see CAUTION above).
4. Activates the left reel motor in a clockwise direction (ALD FT283) taking tape out of the left column.

When Reels Loaded is sensed, the pneumatics motor is dropped and both reels turn counterclockwise until all the tape is on the right reel.

**Notes:**

- + Indicates nominal MST-1 plus (up) level of -0.85 Vdc; line should have solid up level or go to the up level.
- Indicates nominal MST-1 minus (down) level of -1.85 Vdc; line should have solid down level or go to the down level.
- [1] Plus level is 0 Vdc and minus level is -4 Vdc. With vacuum present and tape above the port, the level will be plus.
- [2] Plus level is +12 Vdc and minus level is 0 Vdc.
- [3] If the right reel does not stop, tape damage may occur.

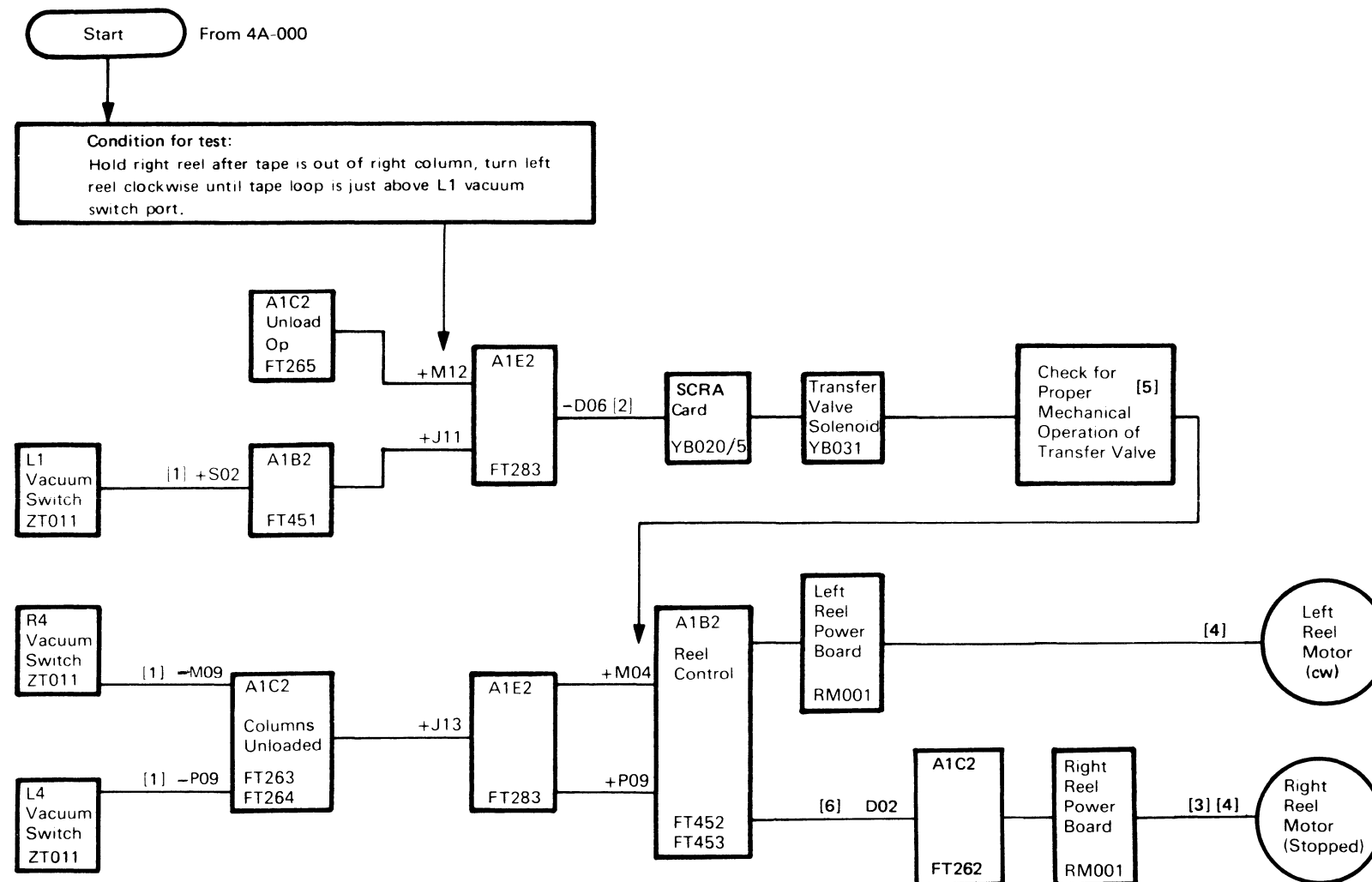

3803-2/3420

<b>XB2500</b>	<b>2735768</b>	<b>See EC History</b>	<b>845958</b>	<b>847298</b>				
Seq 2 of 2	Part Number		1 Sep 79	15 Aug 83				

© Copyright International Business Machines Corporation 1976, 1979, 1983

# TAPE DOES NOT WIND COMPLETELY ONTO RIGHT REEL OR REELS DO NOT STOP

As tape is removed from the columns, tape tightens over the Reels-Loaded switch, located in the left threading channel. Then both reels turn counterclockwise, taking up tape until the end of the tape passes the beginning-of-tape/end-of-tape (BOT/EOT) phototransistors. This deactivates Tape Present (ALD FT281). Delay in the Tape Present circuits causes the right reel to continue turning until the tape is completely restored to the right reel. If reels do not stop, use Start A. If tape does not wind completely onto the right reel, use Start B'.

**Notes:**

- + Indicates nominal MST-1 plus (up) level of -0.85 Vdc; line should have solid up level or go to the up level.
- Indicates nominal MST-1 minus (down) level of -1.85 Vdc; line should have solid down level or go to the down level.
- [2] Plus (up) level is 0 Vdc and minus (down) level is -4 Vdc.
- [3] Typical voltage levels: +1.6 Vdc dark and less than +1.5 Vdc light.
- [4] Special voltage levels: 0 Vdc to -4 Vdc.
- [5] Positive when tape is taut across left threading channel and vacuum is present.
- [6] Drives counterclockwise when Reels Loaded is active.
- [7] If this level is incorrect, perform the BOT/EOT adjustment before checking the T-A1D2 card inputs. See 08-580.

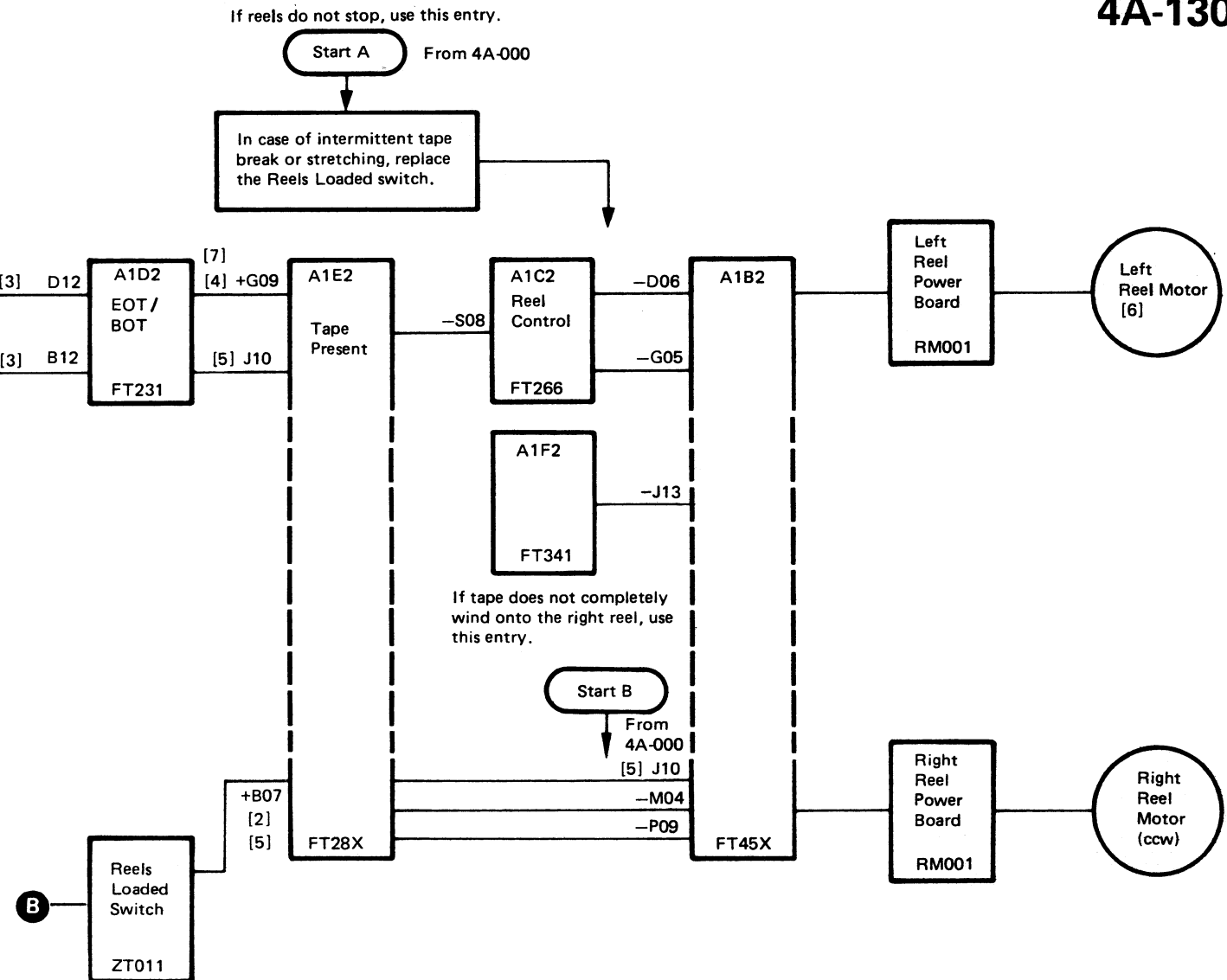
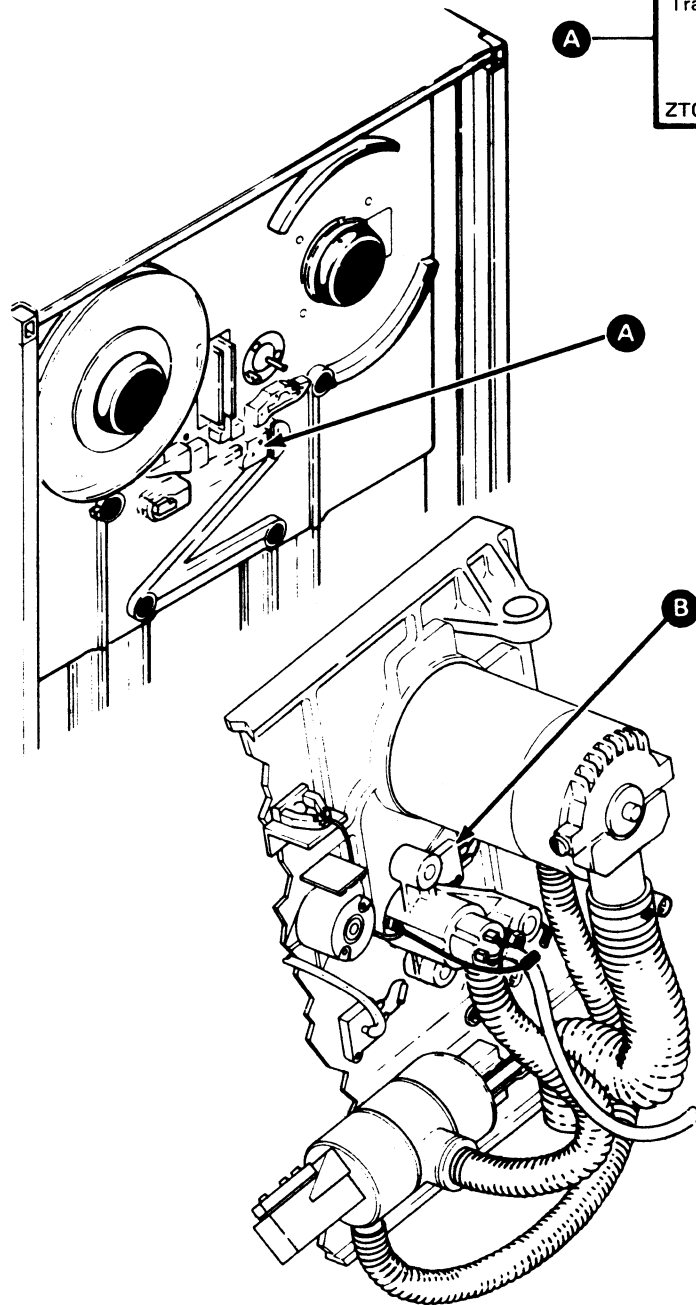

3803-1,2,3/3420

XB2600	2735769	See EC History	845958	846927	847298			
Seq 1 of 2	Part Number		1 Sep 79	20 Jun 80	15 Aug 83			

© Copyright International Business Machines Corporation 1976, 1979, 1980, 1983

# POWER WINDOW DOES NOT GO DOWN

The power window provides access to the right reel for loading and unloading. The window is raised only when either the LOAD REWIND or RESET pushbuttons are pressed. It is lowered when an Unload operation has been completed.

The window is raised by a motor-driven rack and gear assembly. It is counterbalanced by springs. To maintain window alignment, an idler roller on each side of the window rolls in guides.

The motor is controlled by a relay, the Window-Up switch, and the Window-Down switch. Motor direction is determined by the direction of motor current. When either the LOAD REWIND or RESET pushbuttons are pressed, the relay is picked to drive the motor. The motor continues to drive until the Window-Up switch opens, removing voltage from the motor. The relay remains picked while the window is up. The window is lowered by dropping the relay, which reverses the direction of motor current and bypasses the Window-Up switch. Voltage is removed from the motor when the Window-Down switch opens.

The door contains a safety bail. The safety bail is a cable, enclosed in a hollow gasket, stretched across the top of the window. Any object applying sufficient pressure to the safety bail transfers the safety bail switch thereby deactivating the relay. The window drive motor reverses and lowers the window.

### SET UP:

1. If the window fails to go down when the UNLOAD REWIND pushbutton is pressed, start testing at Start A.
2. If the window fails to go down on a programmed Unload/Rewind, or from the 3803, start at Start B.

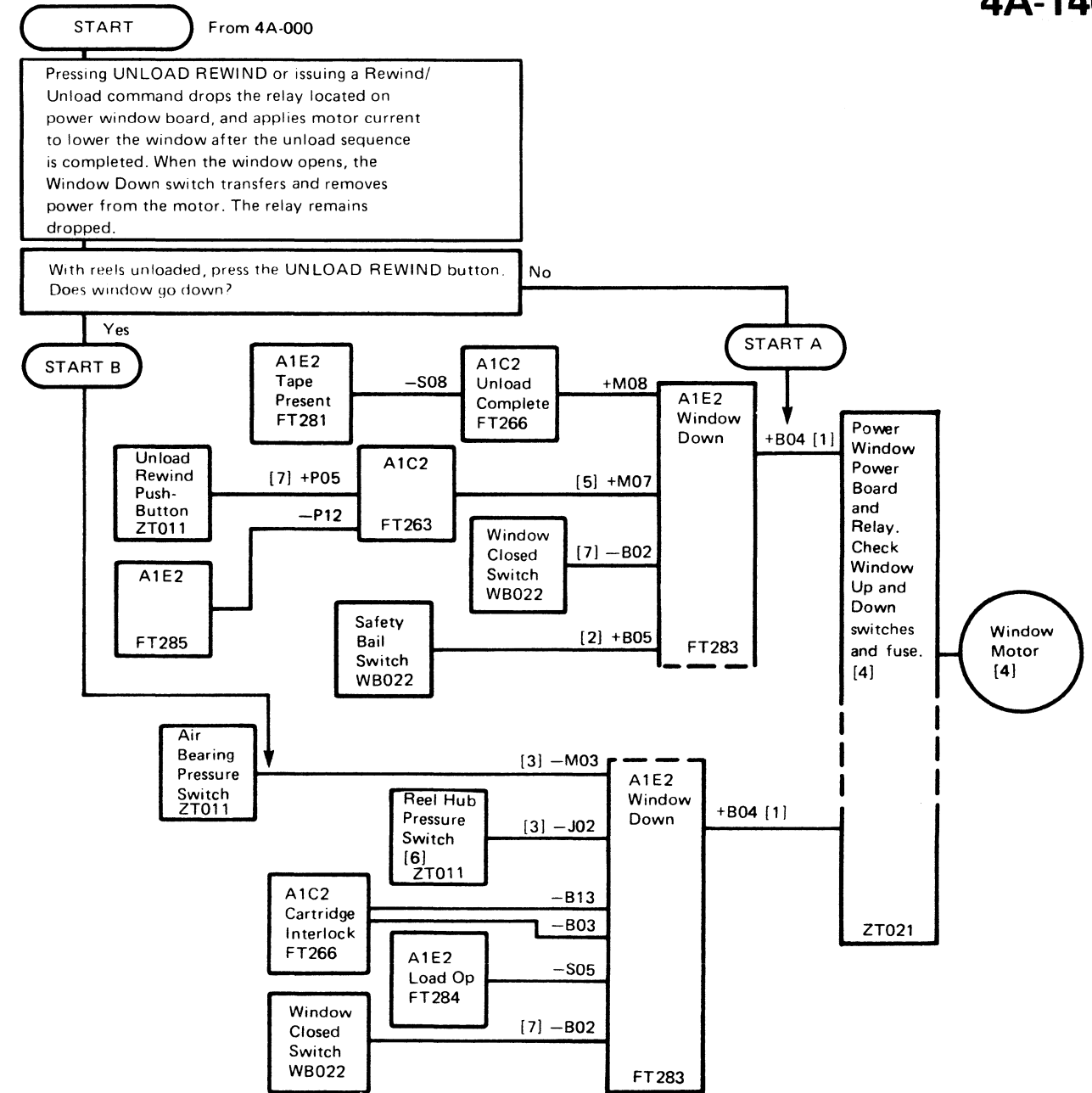
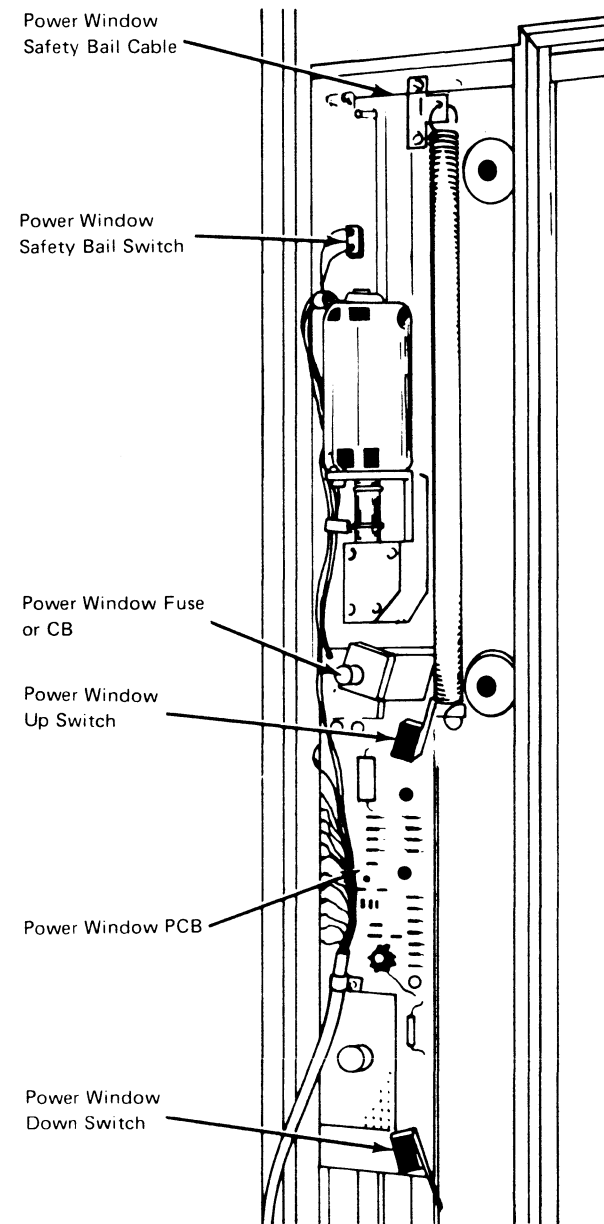

### Notes:

- + Indicates nominal MST-1 plus (up) level of -0.85 Vdc; line should have solid up level or go to the up level.
- Indicates nominal MST-1 minus (down) level of -1.85 Vdc; line should have solid down level or go to the down level.
- [1] Plus level is +12 Vdc and minus level is 0 Vdc.
- [2] Special voltage: 0 Vdc to +6 Vdc if the switch is activated.
- [3] Plus level is 0 Vdc and minus level is -4 Vdc. Level is minus when pneumatics are off.
- [4] Verify that the window motor retaining screws are tight.
- [5] Line level should be plus with the UNLOAD REWIND pushbutton pressed, or safety bail activated.
- [6] If EC 734952 is installed, the pneumatics drop when the Reels Loaded switch makes.
- [7] Special voltage: 0 Vdc to -4 Vdc.

3803-1,2,3/3420

<b>XB2600</b> Seq 2 of 2	<b>2735769</b> Part Number	<b>See EC History</b>	<b>845958</b> 1 Sep 79	<b>846927</b> 20 Jun 80	<b>847298</b> 15 Aug 83			
-----------------------------	-------------------------------	-----------------------	---------------------------	----------------------------	----------------------------	--	--	--

© Copyright International Business Machines Corporation 1976, 1979, 1980, 1983



# CARTRIDGE OPENER DOES NOT CLOSE

Deactivating Tape Present turns on Unload Complete (ALD FT266), which resets the Cartridge Hold latch (ALD FT282). This starts the cartridge motor and closes the cartridge. When the Cartridge Closed switch transfers, the cartridge motor stops.

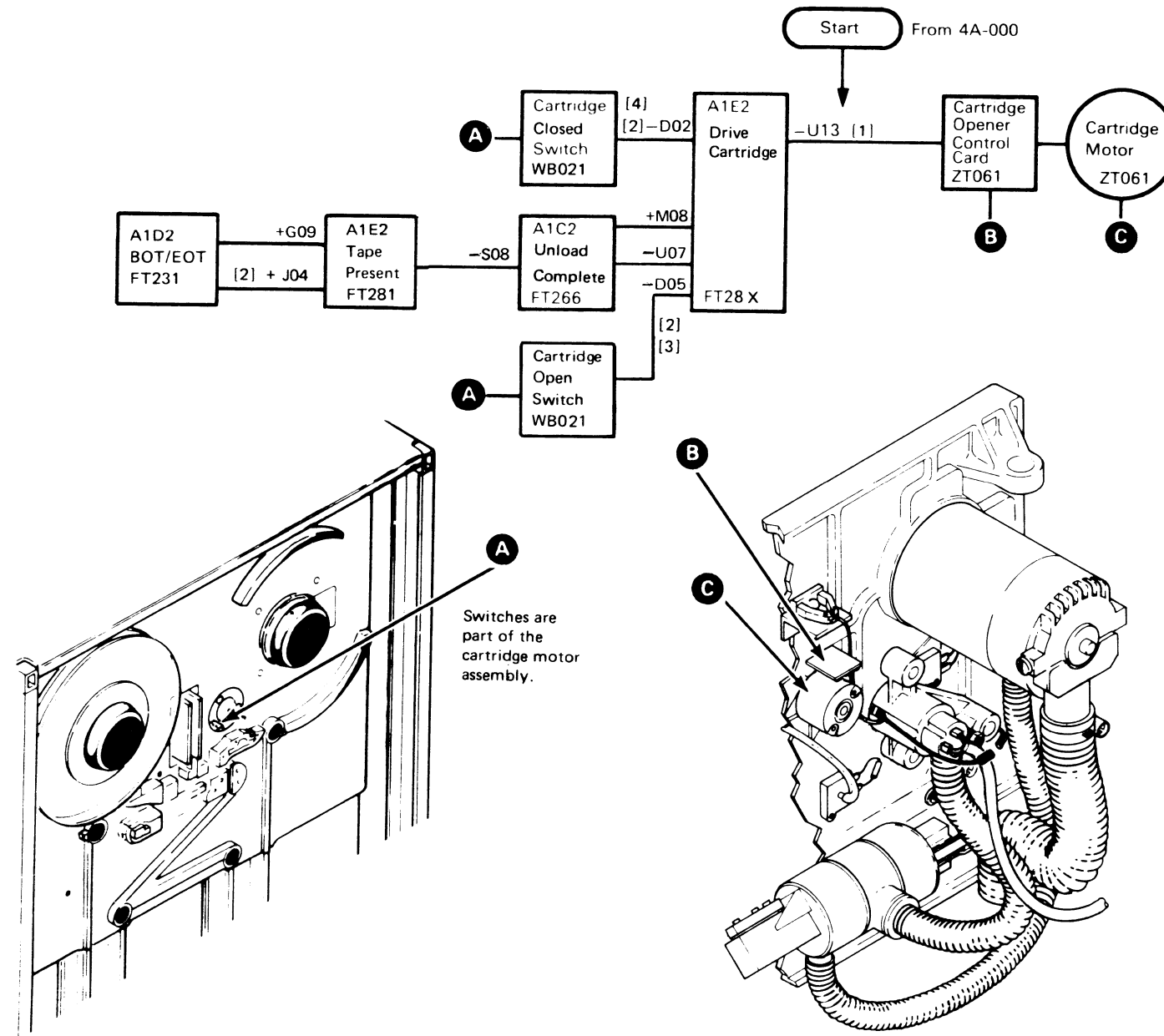

**Notes:**

- + Indicates nominal MST-1 plus (up) level of -0.85 Vdc; line should have solid up level or go to the up level.
- Indicates nominal MST-1 minus (down) level of -1.85 Vdc; line should have solid down level or go to the down level.
- [1] Plus (up) level is +12 Vdc and minus (down) level is 0 Vdc.
- [2] Special voltage: 0 Vdc to -4 Vdc.
- [3] Cartridge open switch is plus (0 volts) when the cartridge is fully open.
- [4] Cartridge closed switch is plus (0 volts) when the cartridge is fully closed.

3803-1.2,3/3420

<b>XB2700</b> Seq 1 of 2	<b>2735770</b> Part Number	<b>See EC History</b>	<b>845958</b> 1 Sep 79	<b>847298</b> 15 Aug 83			
-----------------------------	-------------------------------	-----------------------	---------------------------	----------------------------	--	--	--

© Copyright International Business Machines Corporation 1976, 1979, 1983

**PNEUMATIC MOTOR DOES NOT TURN OFF**

**PNEUMATIC SYSTEM – THEORY**

Two pneumatic pumps supply all vacuum and air pressure required for machine operation.

The distribution of air and vacuum is controlled by a transfer valve and a three-way valve.

Vacuum is used for:

- Tape threading
- Reel loading
- Column loading
- Tape in column sensing
- Capstan motor cooling
- Tape cleaning

Air pressure is used for:

- Tape threading
- Reels loaded sensing
- Holding the file protect plunger retracted
- Retracting the tape guides
- Forcing tape away from the heads during high speed rewind
- Air bearings
- Automatic reel latch
- General machine cooling
- High speed rewind plunger

**TRANSFER VALVE**

The transfer valve controls the distribution of vacuum, which is different for a threading operation than for all other operations.

**THREE-WAY VALVE**

The three-way valve is spring-loaded to the normal, Thread Status Inactive position. During Thread Status Active, the three-way valve is actuated by the transfer valve solenoid. See the diagram on 4A-161.

**PNEUMATIC SWITCHES**

Pneumatic switches sense the absence or presence of air pressure and vacuum throughout the pneumatic system. The switches indicate the position of tape in the vacuum columns, the reels-loaded condition, air bearing pressure, automatic reel latch pressure, and file protect status.

**AIR BEARINGS**

Air bearings are positioned at three places in the tape path:

1. At the top of the right tapered column.
2. At the bottom of the right tapered column.
3. At the bottom of the left tapered column.

Air is forced through holes in the bearings to produce a thin film of air on which the tape rides.

**Notes:**

- + Indicates nominal MST-1 plus (up) level of -0.85 Vdc; line should have solid up level or go to the up level.
- Indicates nominal MST-1 minus (down) level of -1.85 Vdc; line should have solid down level or go to the down level.

- [1] Refer to ALD YB030/5 or YB010/5.
- [2] Plus level is +12 Vdc and minus level is 0 Vdc.
- [3] Special voltage: 0 Vdc to -4 Vdc.

**Without EC 734952**

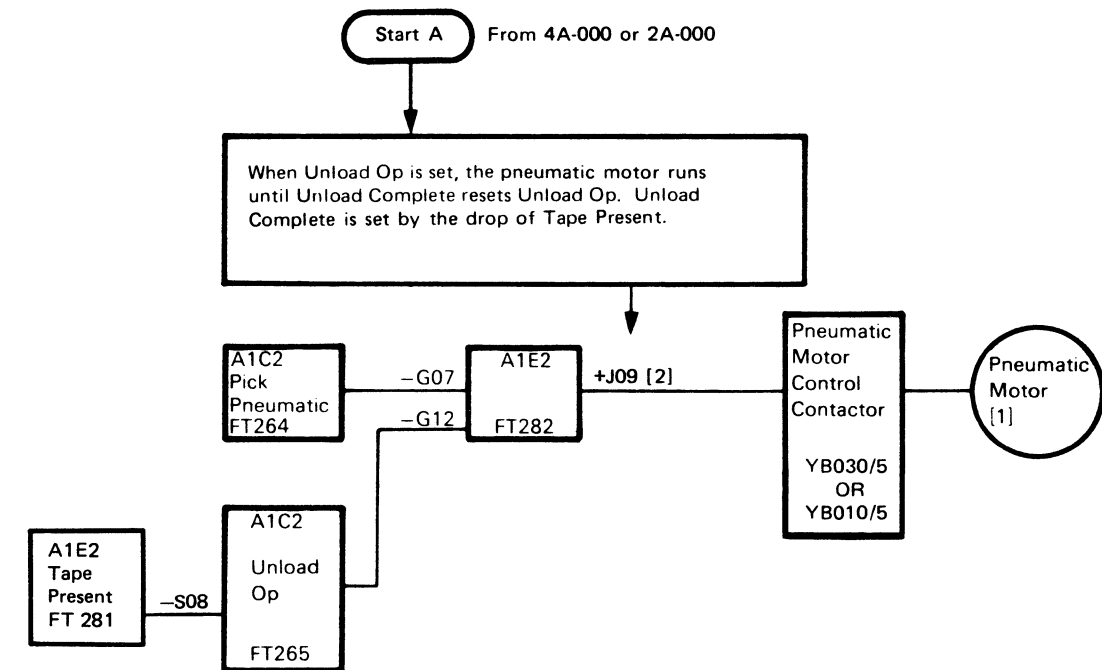

**With EC 734952**

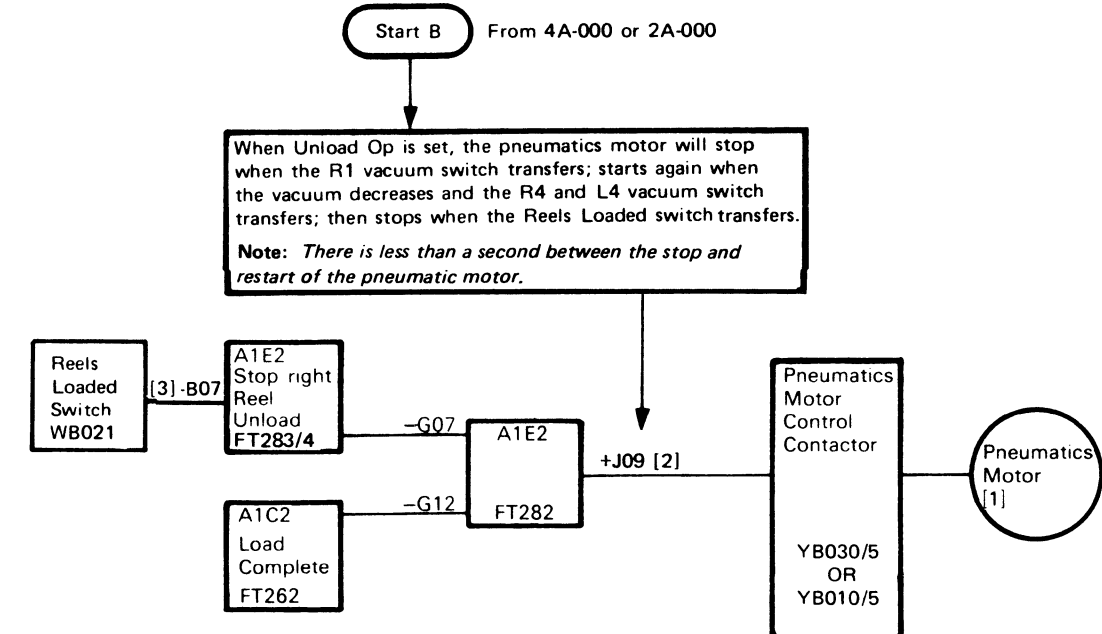

3803-1,2,3/3420

XB2700	2735770	See EC History	845958	847298				
Seq 2 of 2	Part Number		1 Sep 79	15 Aug 83				

© Copyright International Business Machines Corporation 1976, 1979, 1983

**PNEUMATIC SYSTEM**

**4A-161**

**THREAD STATUS ACTIVE**

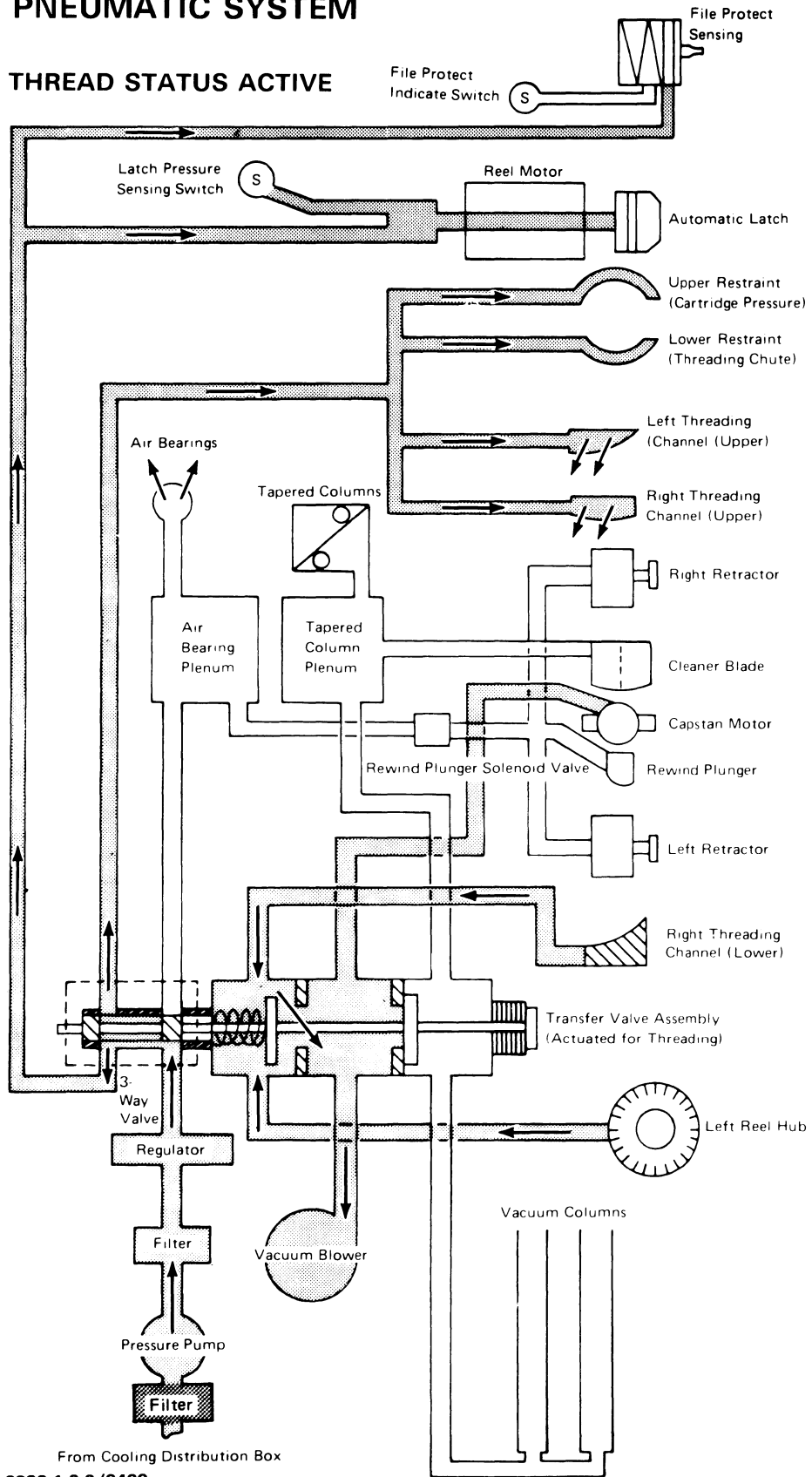

**THREAD STATUS INACTIVE**

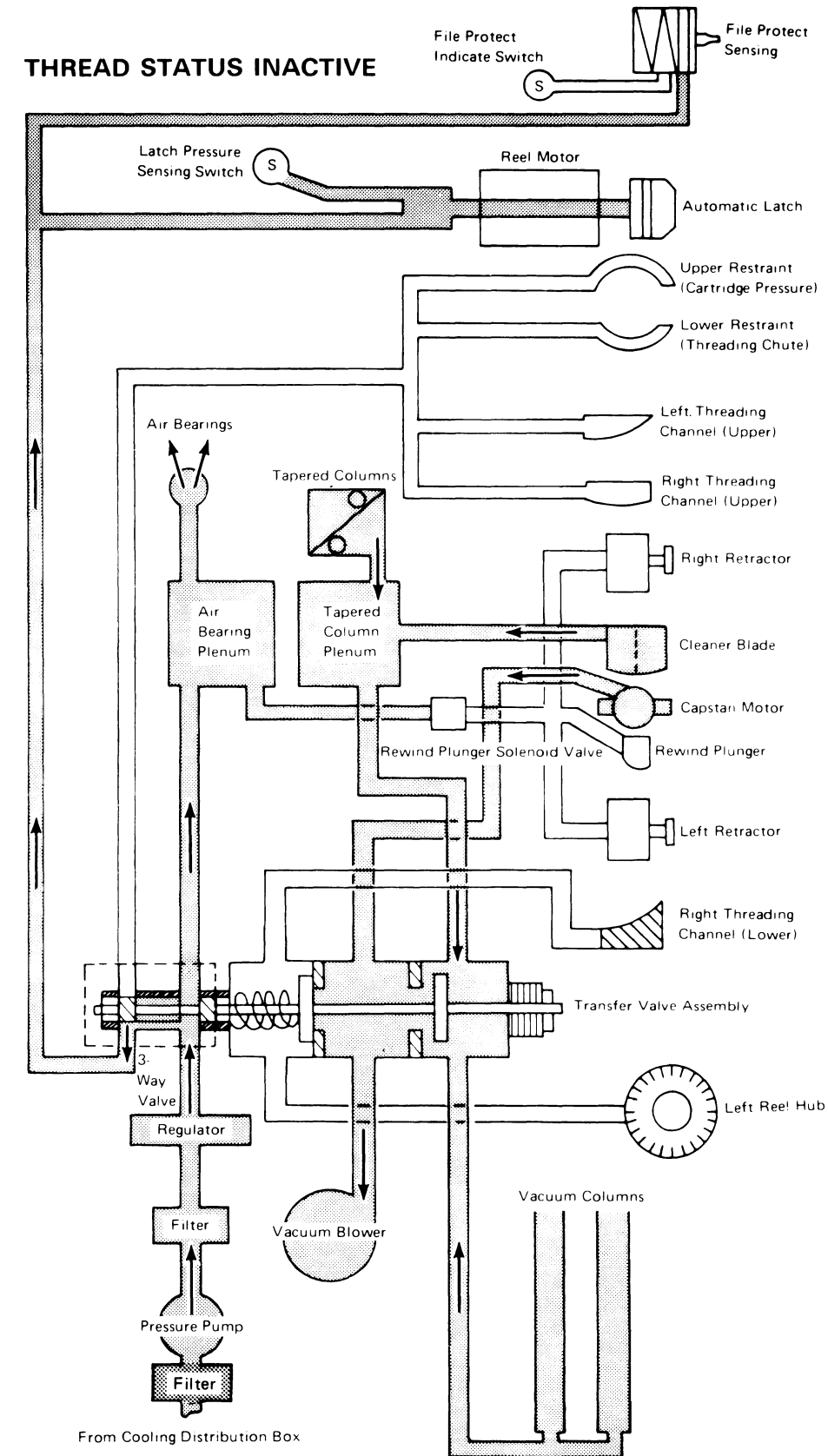

From Cooling Distribution Box

3803-1,2,3/3420

<b>XB2750</b>	<b>2736040</b>	<b>See EC</b>	<b>845958</b>						
Seq 1 of 2	Part Number	History	1 Sep 79						

© Copyright International Business Machines Corporation 1976, 1979

**4A-161**

NOTES:

4A-162

3803-1,2,3/3420

<b>XB2750</b> Seq 2 of 2	<b>2736040</b> Part Number	<b>See EC</b> <b>History</b>	<b>845958</b> 1 Sep 79						
-----------------------------	-------------------------------	---------------------------------	---------------------------	--	--	--	--	--	--

© Copyright International Business Machines Corporation 1976, 1979

4A-162



# ENVELOPE FAILURE, RUNAWAY, OR READ/WRITE PROBLEMS

5A-000

**Error Description:** This MAP helps diagnose problems involving the Write Card, the Read Card, the Read Write Head, the Erase Head, and the Read, Write, and Erase controls. Use this MAP with diagram 5A-100. If the problem is permanent read/write errors, refer to 00-011 for further assistance.

- Most Probable Causes:**
1. Read head card defective.
  2. Write head card defective.
  3. T-A1L2, T-A1J2, T-A1M2 (NRZI) defective.
  4. R/W head defective.
  5. Erase head defective.
  6. Capstan motor.

- Initial Checks:**
1. Air pressure and vacuum. See 08-400.
  2. -4 Vdc and +6 Vdc supply in tolerance. See 08-570.
  3. R/W head and cleaner blade must be clean.
  4. Capstan squaring. See 08-130.
  5. NRZI skew.

If any of the Initial Checks indicate a problem, take the action necessary but verify that the original problem still exists before continuing with this MAP (run OLTEP, 3420 A to Z, etc).

**Always** start with Seq 1 and follow the procedure in sequence unless directed otherwise. **Remember** to END all problem or maintenance calls by going to MAP 00-030.

Seq	Condition/Instruction	Action
1	Is this the first time through this MAP?	Go to Seq 3.
2	If not:	Go to 5A-105.
3	Field tester setup: 1. Load a scratch tape a Write Enable ring and make the drive READY. 2. Is File Protect light on?	Go to Seq 20.
	1. Set to Write. 2. Set the 8/16/32 switch to 32 for phase encode or 8 for NRZI. 3. Sync scope on +Go at T-A1F2J12. 4. Set scope Horiz to 1.0 ms and vertical to .5V/cm. 5. Set tester to Fwd and St/Stp. Move Go Up and Go Down to display a complete envelope. 6. Scope analog test points at point <b>A</b> on 5A-100.	Go to Seq 4.
4	Are all tracks missing?	Go to Seq 12.
5	Are any tracks missing?	Go to Seq 22.
6	Are all tracks within 20% of each other in amplitude?	Go to Seq 25.
7	Is failing mode NRZI?	Go to Seq 30.
8	Adjust the amp sensors. See 08-000.	Go to Seq 9.
9	Are all the tracks within 20% of each other in amplitude?	Go to 00-030.
10	Change the Read head card. Are all the tracks now within 20% of each other in amplitude?	Go to 00-030.

Seq	Condition/Instruction	Action
11	If not:	Change the R/W head and readjust the amp sensors. Go to 00-030.
12	Is the High Speed rewind plunger operating correctly? See Operational Check on 08-000.	Go to Seq 15.
13	Repair or replace as necessary. Is the drive operating correctly?	Go to 00-030.
14	Is the line at T-A1H2M09 plus?	Go to Seq 20.
15	Scope the Write Data lines starting at entry C on 5A-100. Are all pulsing?	Change the Write head card. If not fixed, go to Seq 34.
16	If not:	Change T-A1J2. Go to 00-030.
17	Replace the R/W head. Is the drive fixed?	Go to 00-030.
18	Check the cables from the Read head to the A1 logic panel for shorts, opens, or loose cables. Was the trouble found?	Go to 00-030.
19	If not:	Recheck symptoms. Go to 00-030.
20	Is the line at T-A1H2M10 plus?	Change T-A1H2. Go to 00-030.
21	If not:	Go to ALD WB021 and follow line to the failing point. Components include the File Protect mechanism and the NFP relay and card. See ALD ZT071.
22	Scope the Write Data lines for missing tracks, starting at entry C on 5A-100. Are they pulsing?	Change the Write head card. If not fixed, go to Seq 34.
23	Scope Bus Out lines at input to T-A1J2 (see 5A-100). Are the inputs pulsing?	Replace T-A1J2. Go to 00-030.
24	If not:	Go to Seq 29.

Seq	Condition/Instruction	Action
25	Scope inputs at points <b>D</b> on 5A-100. Are they pulsing?	Go to Seq 27.
26	If not:	Replace the read head card (see 08-260). Go to 00-030.
27	Disconnect the interface cable. Put the drive Online/Offline switch to Online. Scope pins at point <b>F</b> on 5A-100. Are the signals pulsing?	If fixed, go to 00-030. If not fixed, go to 5A-105.
28	If not:	Replace T-A1L2. Go to 00-030.
29	Check the field tester and cabling for operation. Look for possible opens or shorts in the cable wiring.	Go to 00-030.
30	Are the inputs to T-A1L2 at points <b>G</b> on 5A-100 pulsing?	Go to Seq 27.
31	Scope inputs at points <b>D</b> on 5A-100. Are inputs pulsing?	Change T-A1M2 or T-A1L2. Go to 00-030.
32	Scope the outputs of T-A1K2. Are they pulsing?	Change T-A1J2. Go to 00-030.
33	If not:	Change T-A1K2. Go to 00-030.
34	Replace the Read head card. Is the drive fixed?	Go to 00-030.
35	If not:	Go to Seq 17.

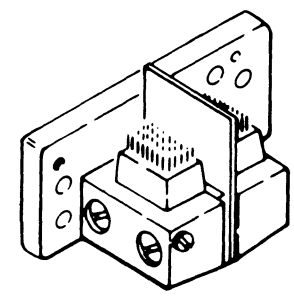

Read/Write Head

3803-2/3420	<b>XB2800</b> Seq 1 of 2	<b>2735771</b> Part Number	<b>See EC History</b>	<b>845958</b> 1 Sep 79	<b>847298</b> 15 Aug 83				
-------------	-----------------------------	-------------------------------	-----------------------	---------------------------	----------------------------	--	--	--	--

5A-000

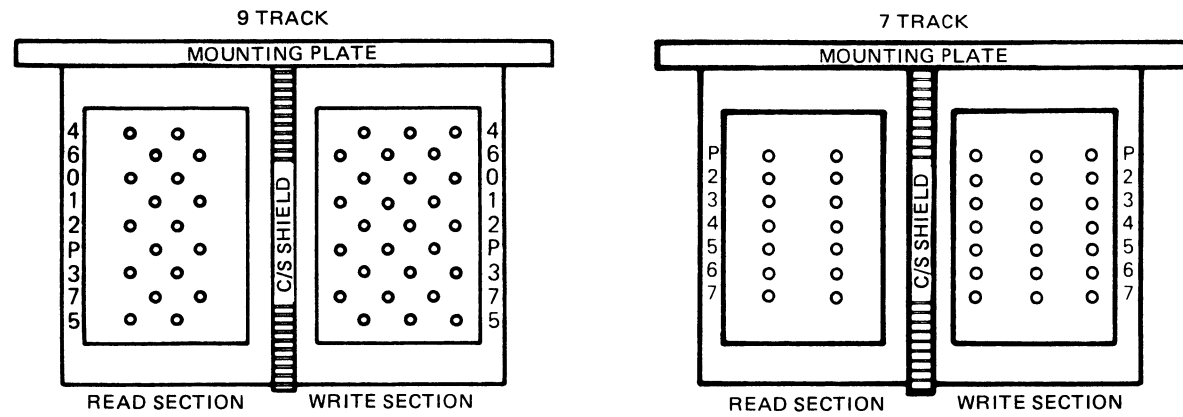

NOTE: The center tap is the middle pin on each track

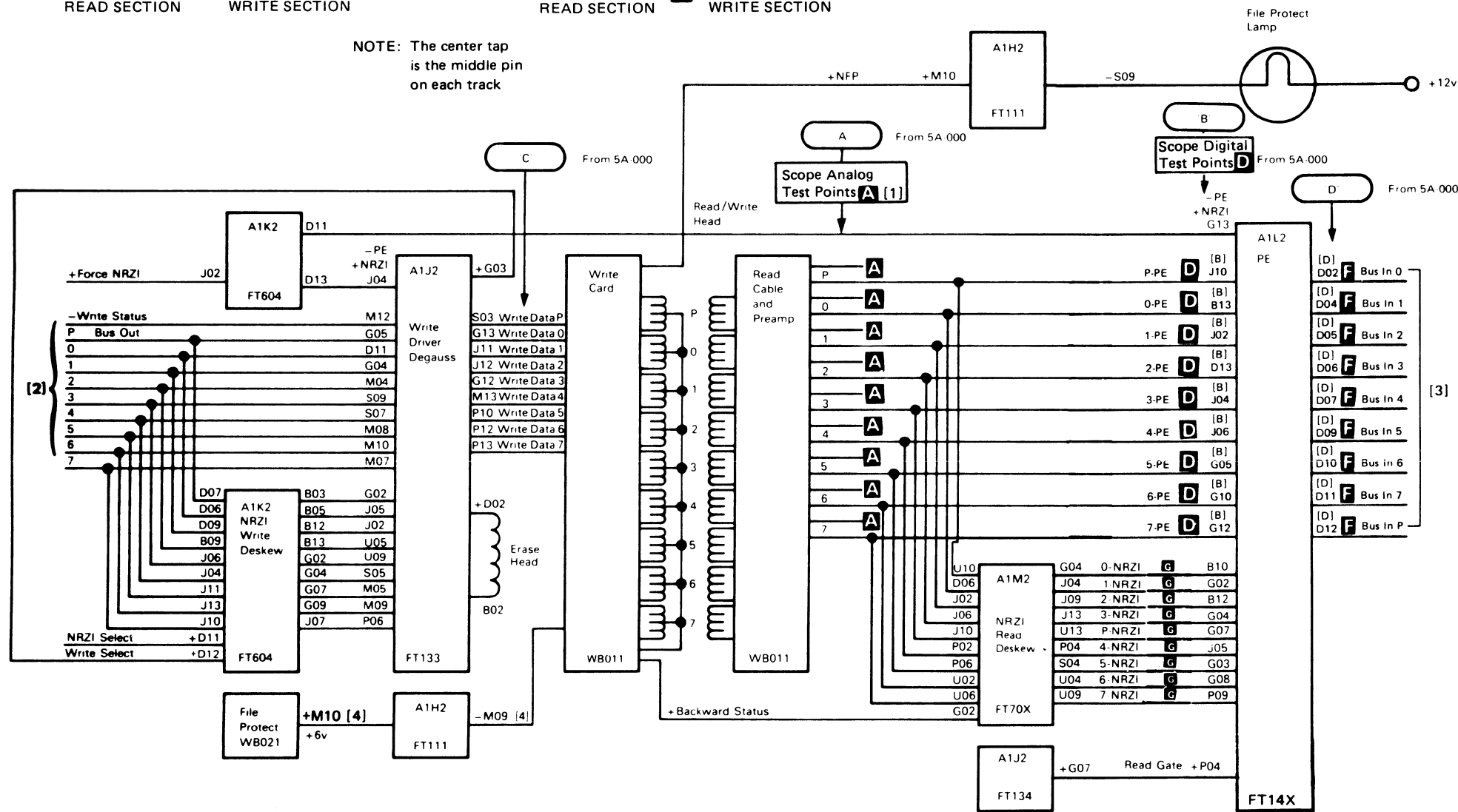

Notes:

- + Indicates nominal MST-1 plus (up) level of -0.85 Vdc; line should have solid up level or go to the up level.
- Indicates nominal MST-1 minus (down) level of -1.85 Vdc; line should have solid down level or go to the down level.
- [1] Test points P through 7 are under the decorative cover on the front of the tape unit. Refer to the decal inside the cover.
- [2] Input is from ALD FT101.
- [3] If offline, these pins are degated.
- [4] Special voltage: +6 Vdc to ground.

**D** Set Up Scope Horizontal to 1μs Vertical to 5v

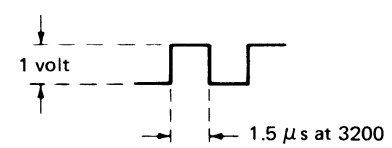

**F** Set Up Scope Horizontal to 1 μs Vertical to 10v scale

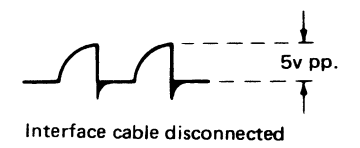

Trk	Phys Pos *		A	B
	9-Trk	7-Trk		
P	4	7	J2D10	J2B10
0	7		J2D04	J2B04
1	6		J2D05	J2B05
2	5	6	J2D06	J2B06
3	3	5	J2D11	J2B11
4	9	4	J2D02	J2B02
5	1	3	J2D13	J2B13
6	8	2	J2D03	J2B03
7	2	1	J2D12	J2B12

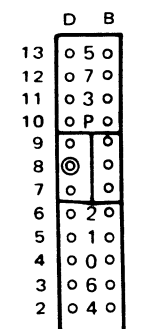

\*Front to back on head J2D08 is dc common

J2 Front View

3803-2/3420					
<b>XB2800</b>	<b>2735771</b>	<b>See EC</b>	<b>845958</b>	<b>847298</b>	
Seq 2 of 2	Part Number	History	1 Sep 79	15 Aug 83	

PERMANENT DATA CHECKS

This MAP covers adjustments and service checks not previously covered.		
<b>Most Probable Causes:</b>		
<ol style="list-style-type: none"> <li>1. Media, see 00-011.</li> <li>2. Read Head card.</li> <li>3. R/W head (head may be dirty)</li> <li>4. Write head card.</li> <li>5. Capstan motor.</li> <li>6. T-A1L2, T-A1J2, T-A1H2.</li> <li>7. Vacuum column door adjustment.</li> <li>8. Transfer valve.</li> <li>9. Loose pneumatic hoses.</li> <li>10. Erase Head.</li> <li>11. Worn or dirty cleaner blade.</li> </ol>		
<b>Always</b> start with Seq 1 and follow the procedure in sequence unless directed otherwise. <b>Remember</b> to END all problem or maintenance calls by going to MAP 00-030.		
Seq	Condition/Instruction	Action
1	Does error occur on more than one tape?	Go to Seq 3.
2	Is the failing tape available for analysis?	Go to 00-011 Permanent Read/Write Error Analysis.
3	Problem may be Media related. Perform the following procedures to assure tape unit meets criteria. For highly intermittent errors do all checks and adjustments in this map before returning tape unit to customer.	
4	Perform power supply checks on 08-570 check with the tape unit loaded and in write status. Make sure ripple is within tolerance.	
5	Is power supply within tolerance?	Go to Seq 7.
6	If not:	Adjust/Repair/Replace as necessary
7	Set up tester for a Write. Ensure that tape is at load point. Bring up GO at the tester and move tape away from LOAD point. Set switch to STOP. The erase head should now be ON.	
8	Is -Erase Head On (T-A1H2P13) minus?	Leave the tester in write stop mode for 2-3 minutes more, then go to Seq 11.
9	Is -Write Status Drive (T-A1H2M09) minus?	Go to Seq 12.
10	If not:	Change T-A1H2 and go to 00-030.
11	Unload the tape unit, open the vacuum column door and feel the erase head. Is the erase head warm?	Go to Seq 16.

Seq	Condition/Instruction	Action
12	Unplug the head cable from the write card and check the erase head for an open or short. Resistance should be approximately 22 ohms. Is the erase head open or shorted?	Change the erase head and go to 00-030.
13	Is the resistance correct?	Change the write head card and go to 00-030.
14	Perform the erase head polarity check on 08-320. Is polarity correct?	Go to Seq 16.
15	If not:	Correct erase head polarity and go to 00-030.
16	Check and degauss cleaner blade. See 08-390. Is cleaner blade ok?	Go to Seq 18.
17	If not:	Replace cleaner blade and go to 00-030.
18	Perform the tape guide check on NRZI featured machines. See 08-230. Check performed OK or PE only machine.	Go to Seq 20.
19	If not:	Adjust/Repair/Replace as necessary.
20	Check the capstan dynamic alignment. See 08-150 or 08-160. Is alignment good?	Go to Seq 22.
21	If not:	Adjust as required. Go to 00-030.
22	Check the drive mechanical skew. See 08-170 or 08-180. Is the mechanical skew within tolerance.	Go to Seq 24.
23	If not:	Adjust/Repair as necessary.
24	Does the tape unit have NRZI feature?	Go to Seq 34.
25	Check the PE Amp sensors. See 08-290. Are Amp sensors operating correctly?	Go to Seq 27.
26	If not:	Adjust as necessary and go to 00-030.
27	Check the Forward to Backward ratio. See 08-240. Is the ratio within tolerance?	Go to Seq 29.
28	If not:	Replace read/write head and go to 00-030.
29	Check feedthrough. See 08-330. Is feedthrough within tolerance?	Go to Seq 31.
30	If not:	Replace read/write head and go to 00-030.
31	Do procedure on 6A-010 and return.	

Seq	Condition/Instruction	Action
32	Disconnect the tape interface cable. Put the ONLINE/OFFLINE switch to ONLINE. Set the field tester to Write, Fwd, St/stp, and the density to 32. Check Bus In to the control unit at point F on 5A-100. Do any of the tracks have noise in the IBG? See 5A-115.	Go to Seq 41.
33	All major adjustments have been performed. Run all read/write diagnostic procedures then return machine to customer.	Go to 00-030.
34	Does the drive fail in PE mode only?	Go to Seq 25.
35	Check NRZI amp sensors. See 08-300. Are the NRZI amp sensors operating properly?	Go to Seq 37.
36	If not:	Adjust/Replace as necessary and go to 00-030.
37	Check the NRZI read skew. See 08-190. Is the skew within tolerance.	Go to Seq 39.
38	If not:	Adjust as necessary
39	Check the NRZI write skew. See 08-200. Is the skew within tolerance?	Go to Seq 27.
40	Adjust as necessary	Go to 00-030.
41	Is there noise in the IBG at point D on 5A-100?	Go to Seq 43.
42	If not:	Change T-A1L2 and go to 00-030.
43	Is -Zero threshold minus for the track that has the noise in the IBG?	Change T-A1K2 and go to 00-030.
44	Is there noise at entry C on 5A-100?	Go to Seq 46.
45	If not:	Change 1. Read head card 2. Write head card 3. Read/write head
46	Is there noise at the input to T-A1L2 on 5A-100?	Check tester and go to 00-030.
47	If not:	Change T-A1J2 and go to 00-030.

3803-1,2,3/3420

XB2810	4169698	See EC	845958	846927	847298		
Seq 1 of 2	Part Number	History	1 Sep 79	20 Jun 80	15 Aug 83		

# READ FORWARD TO BACKWARD RATIO TEST (MODELS 3, 5, 7)

Use this test to help determine if a read/write head needs replacement.

Verify that the tape is tracking correctly before any head replacement because of the above criteria. Perform Field Tester Accuracy check on 08-290 before proceeding.

1. Degauss the head (08-280) and the cleaner blade (08-390).
2. Obtain a customer good quality representative tape and write it at 1600 bpi on the unit being checked. Write it from the field tester with frequency switch set to 32. Rewind.
3. Read forward to the middle of the reel of tape and stop tape.
4. Set the Field Tester as follows:  
ALT DIR  
SLOW  
READ  
UP/FWD DN/BKWD. potentiometers all the way to the back of tester.  
(Adjust DN/BKWD. so tape has a forward creep rather than a backward creep).
5. Sync and Scope the Read card test points to determine the fwd to bkwd ratio. Display 3 or 4 cycles of read signal and use as much of the scope display as possible for measurements (.2v/cm). For ease of recording, scope J2B13 with another probe, this line will go positive when reading backwards.

## BACKWARD

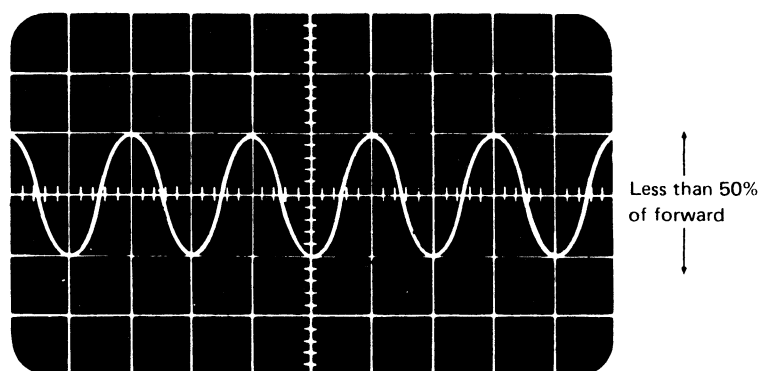

6. If there is a read backward problem, and the amplitude in the backward direction is less than that of the forward direction by 50% on any one track, or 60% on the remaining tracks, the read/write head should be replaced. If head replacement is required, perform the removal/replacement procedure on 08-250, do required adjustments and return to the MAP that sent you here or 00-030. If replacement is not required return to the MAP that sent you here.

## TAPE EDGE DAMAGE

Scope the outside tracks (4 and 5 on 9-track drives or P and 7 on 7-track drives) on the failing record. Look at the amplitude changes.

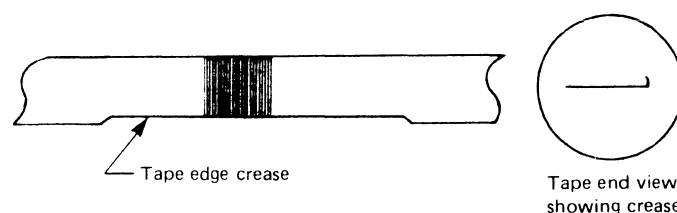

Developing the tape shows that the bits were written on the tape and then the tape was damaged. This type of damage is usually caused by improper tape handling.

**Example:** The tape reel has uneven wraps and the sides of the reel were squeezed, creasing the tape.

## SIGNAL DROPOUT

If possible, scope the failing record and other records on the failing customer tape. Compare envelopes of each track with the waveforms on this page. Review the explanations and Possible Causes. This test requires the use of the tape control unit. If the tape control unit is not available, return to the MAP that sent you here.

1. Set up the tape control unit to read forward and backward over the failing record in the correct density and mode. The Stop On switches should be in the off position.
2. Sync Scope on -Go Forward (see decal on the drive) in the tape drive and display signal at the output of read card (See 5A-100 A). Scope each track and look for signal dropout after the beginning of the envelope.

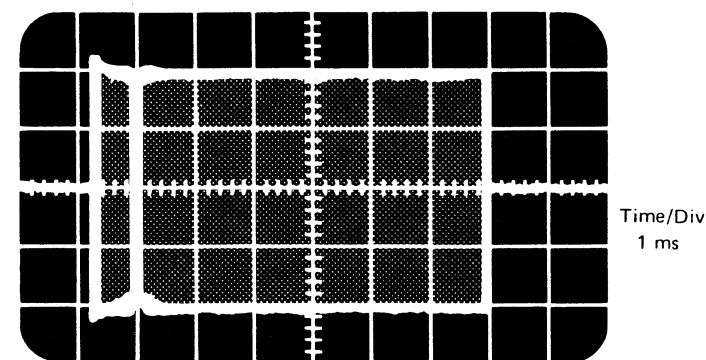

See item 3 for explanation of this area of envelope

## FORWARD

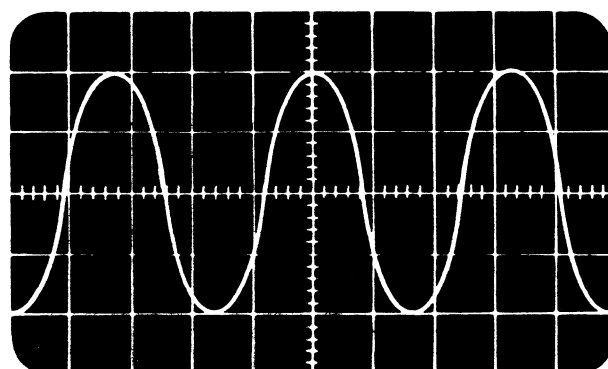

3803-1,2,3/3420

<b>XB2810</b> Sec 2 of 2	<b>4169698</b> Part Number	<b>See EC History</b>	<b>845958</b> 1 Sep 79	<b>846927</b> 20 Jun 80	<b>847298</b> 15 Aug 83			
-----------------------------	-------------------------------	-----------------------	---------------------------	----------------------------	----------------------------	--	--	--

Copyright International Business Machines Corporation 1976, 1979, 1980, 1983



# NOISE OR BITS IN THE INTERBLOCK GAP

To detect interblock gap (IBG) errors, sync scope on -Go Forward. Read forward and backward over the failing record. Display the record in both directions and look for noise in the gap. See the diagrams below.

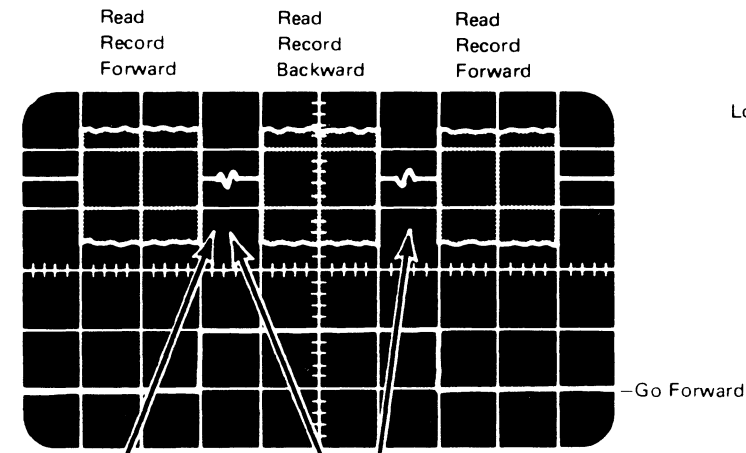

Look for noise in the interblock gap. Amplitude is very low (tape speed is slow).

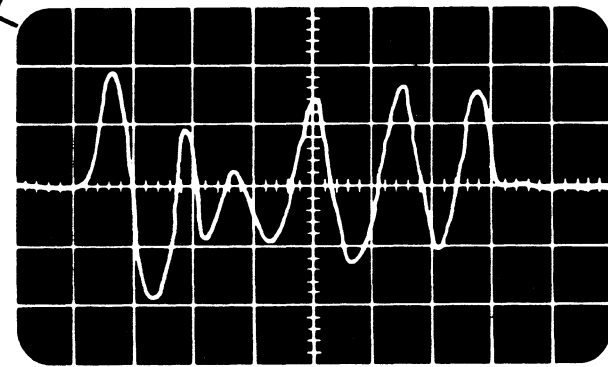

Expanded view of interblock gap

Developing the tape with noise in the IBG shows bits written in the area between two records. These are sometimes faintly recorded.

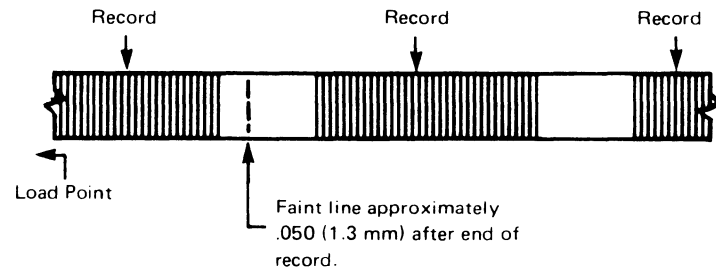

Possible causes of noise bits:

- a. Gaussed or magnetized Read/Write head.
- b. Erase head not working.

## Tape Stretch

Another type of tape damage is tape stretch. Look for a narrowing of the tape as shown:

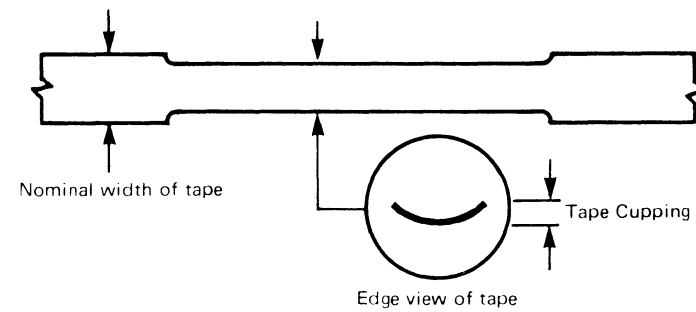

When the stretched section of tape is held in a loop it distorts. Stretched tape usually occurs near the beginning of the reel or in areas of high speed to slow speed rewind.

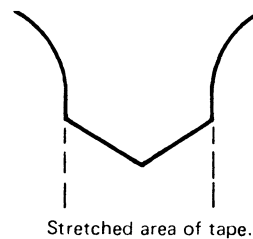
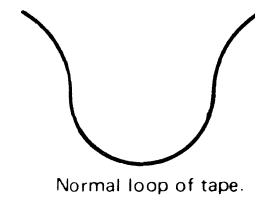

## Bit Packing

Bit packing is due to varying capstan speed or tape slipping.

Set the scope for delayed sweep and look at 1 bit early in the beginning all ones burst of the failing record. Sync scope on a read card test point and look at the digital data on the same track as the sync. Mount the failing tape on a known good drive.

Increase the delay to display the ending all ones burst. The width of the digital data bit in the preamble should be within + 20% of the digital data bit in the postamble.

## BIT PACKING SCOPING PROCEDURE

Use the 3803 subsystem offline or use FRIEND online and mount the failing tape. Read the tape until a failing record is found. Then enter the following commands:

- Read (02)
- Backspace Record (27)
- Read (02)
- Backspace Record (27)

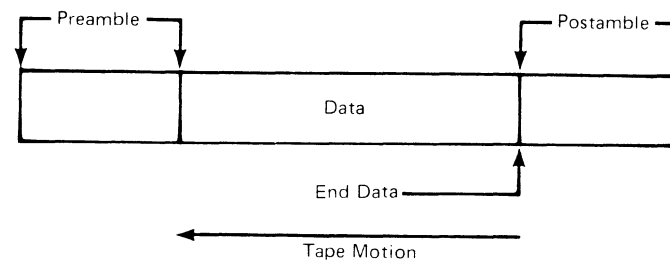

Sync the scope on End Data and scope one of the data tracks at the tape drive or control unit. Measure the length of the postamble in microseconds. Then enter the following commands:

- Read Backward (0C)
- Forward Space Block (37)
- Read Backward (0C)
- Forward Space Block (37)

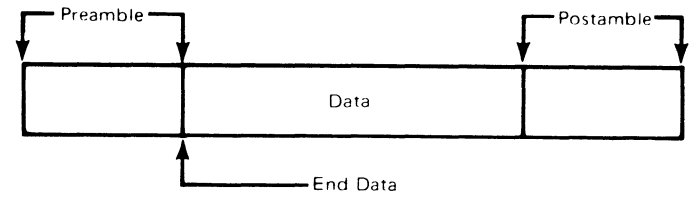

Sync the scope on End Data while scoping one of the digital data tracks at the tape drive or the control unit.

If the preamble is less than the postamble by more than 20%, the preamble is "packed" and may cause drive failures.

## POSSIBLE CAUSES OF BIT PACKING:

- a. Tape slip when written.
- b. Dented capstan.
- c. Vacuum and air pressure out of specification.
- d. Plugged air bearing.
- e. Defective capstan control board.
- f. Binds in the capstan motor.

3803-2/3420

<b>XB2815</b>	<b>4169699</b>	<b>See EC</b>	<b>845958</b>	<b>847298</b>			
Seq 1 of 2	Part Number	History	1 Sep 79	15 Aug 83			

© Copyright International Business Machines Corporation 1976, 1979, 1983

NOTES:

5A-116

3803-1,2,3/3420

<b>XB2815</b> Seq 2 of 2	<b>4169699</b> Part Number	<b>See EC</b> <b>History</b>	<b>845958</b> 1 Sep 79	<b>847298</b> 15 Aug 83				
-----------------------------	-------------------------------	---------------------------------	---------------------------	----------------------------	--	--	--	--

© Copyright International Business Machines Corporation 1976, 1979, 1983

5A-116



# DATA EXCHANGE ON DEVICE INTERFACE DURING A WRITE OPERATION

To perform a write operation, the mounted tape reel must contain a Write Enable ring. The initial tape unit status indicates whether or not this ring is present.

A Write command attempts to set Write Status and resets the Backward latch in the tape unit. However, the tape unit does not return the Write Status indication unless the tape reel has a write enable ring.

- 1 During Initial Selection, the tape control requests sense bytes 0 and 1 from the tape unit to determine what status to include in the initial status byte sent to the channel.
- 2 The tape control resets the tape unit error latches by activating the Command tag and TUBO bit 6.
- 3 The tape control transmits the Write command to the tape unit by activating the command tag and TUBO bit 4.
- 4 The tape unit transmits the command status byte to the tape control on tape unit bus in (TUBI). The tape control compares the status byte with the command and activates Command Status Reject if they do not compare.
- 5 The tape control activates Move to the tape unit. The tape control monitors the Tachometer In/Busy In line to ensure the capstan started. If the tachometer didn't start, Tach Failure error is set.
- 6 The tape unit transmits the tachometer pulses to the tape control if the operation is proceeding normally.
- 7 The tape control waits for gap control (IBG 40 for 9 track or IBG 56 for 7 track) from the tape unit. The tape control holds the Command tag active until Gap Control indication is received. The tape control is measuring the tape speed by measuring the time between tachometer pulses.

- 8 When tape speed is satisfactory, the tape control places data to be written on TUBO.
- 9 When all data is written and has passed the read head, the tape control deactivates Move. The tape unit holds its own Go active until a specified interblock gap (IBG) count is reached.
- 10 The tape control again requests sense bytes 0 and 1 from the status to include in the ending status byte sent to the channel. The bytes are requested and transferred in the same manner as described in step 1.

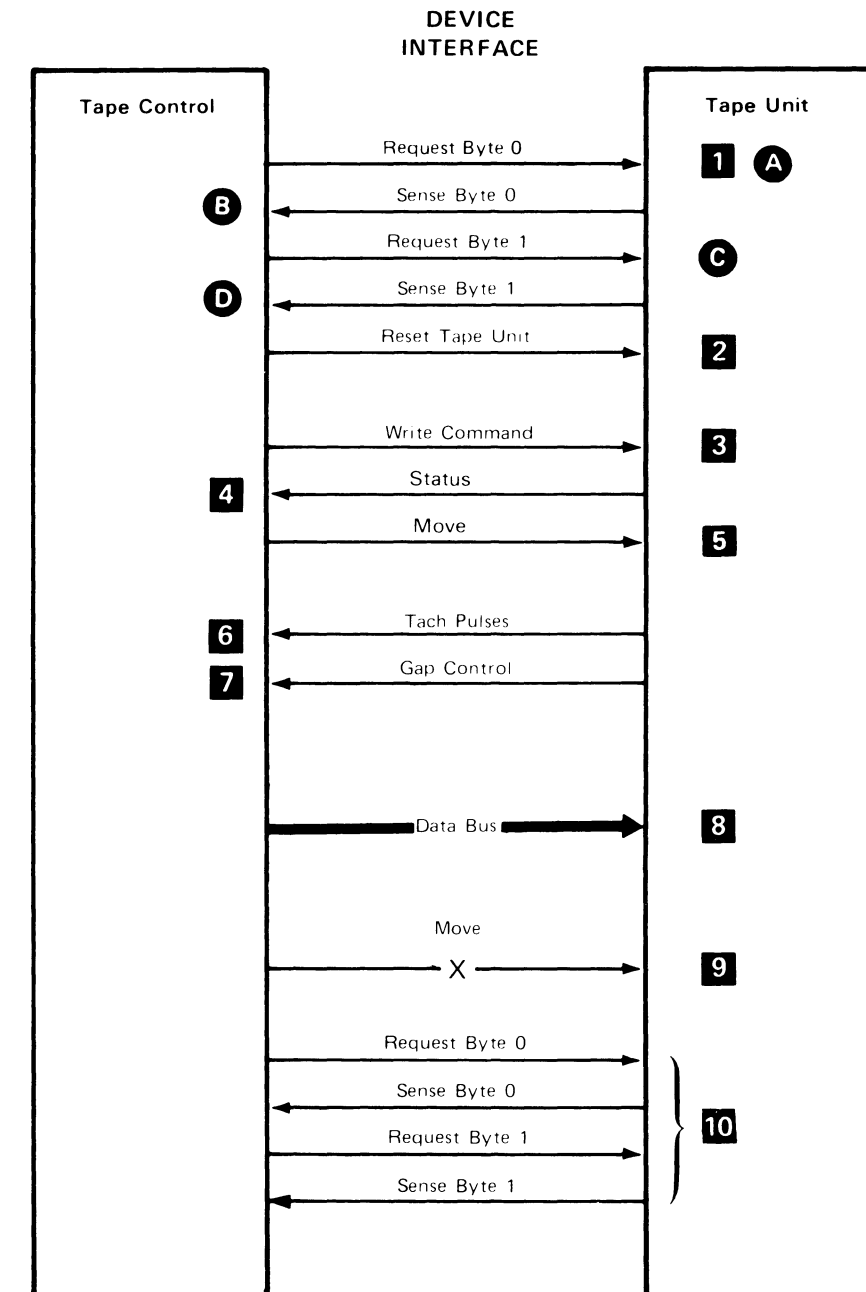

3803-1,2,3/3420

<b>XB2900</b> Seq 1 of 2	<b>2735772</b> Part Number	<b>See EC History</b>	<b>845958</b> 1 Sep 79				
-----------------------------	-------------------------------	-----------------------	---------------------------	--	--	--	--

**READ OPERATION**

**READ FORWARD OPERATION**

- 1 A Read Forward command resets the tape unit's Write Status and Backward latches.
- 2 When its Write Status latch is reset, the tape unit signals the tape control it is in read status.
- 3 The tape control activates the Move tag which sets Go Internal in the tape unit and starts tape motion.
- 4 The Tach Failure Error latch is set in the tape control if no tach pulses are received.
- 5 The tape unit places data read from tape on tape unit bus in (TUBI).
- 6 After all data bytes have been read, the tape control deactivates the Move tag. The tape unit's IBG counter holds the Extended Go line active to control the position of the read head in the interblock gap (IBG) when tape motion is stopped. See page 6A-130 for IBG counter operation.
- 7 The tape control requests sense bytes 0 and 1 from the tape unit. This information is included in the ending status byte sent to the channel.

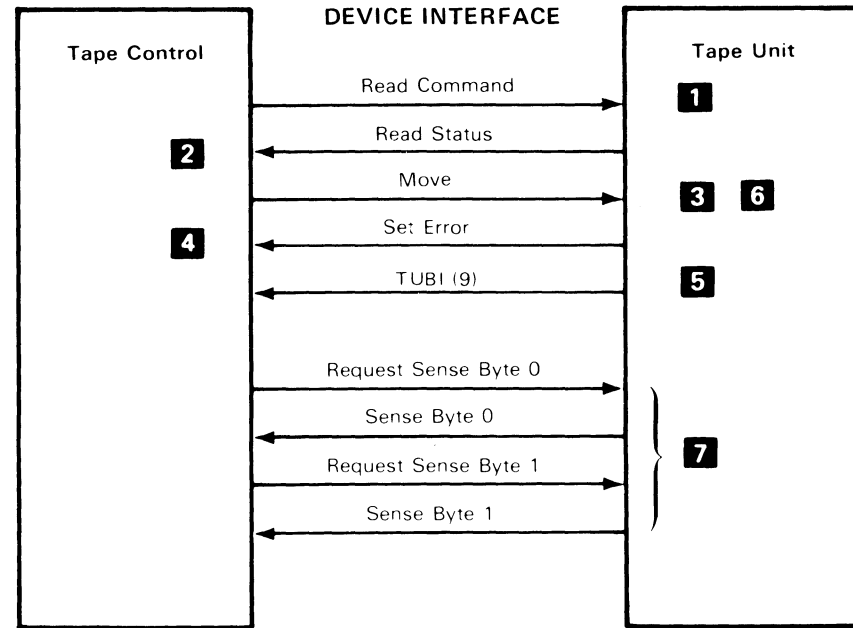

**READ BACKWARD OPERATION**

Read backward is similar to read forward except that tape moves backward. The Backward latch is set when the Read Backward command is issued to the tape unit.

A forward movement is required prior to a backward start if more than 12 milliseconds have elapsed since the last operation.

When the tape control drops Move, the tape drive positions the tape properly in preparation for the next operation.

3803-1,2,3/3420

<b>XB2900</b>	<b>2735772</b>	<b>See EC</b>	<b>845958</b>					
Seq 2 of 2	Part Number	History	1 Sep 79					

© Copyright International Business Machines Corporation 1976, 1979



# CAPSTAN MOTION CONTROL

6A-000

From 00-040, 2A-000		
<b>Most Probable Causes:</b>		
<ol style="list-style-type: none"> <li>Dirty or glazed capstan.</li> <li>Tape drag in the tape path.</li> <li>Incorrect output from capstan squaring circuits.</li> <li>Dirty capstan tachometer.</li> <li>Binding capstan motor.</li> <li>Defective cards T-A1F2, T-A1G2, or T-A1L2.</li> <li>Capstan motor control board.</li> <li>Improper -48 V to capstan board.</li> <li>Pneumatic system failures.</li> </ol>		
Intermittent tape dump in either column can be caused by an open capstan armature. (See Note in Seq 1). To check the capstan armature, unplug the capstan motor cable from the capstan board. With a CE ohmmeter measure the two leads to the capstan motor while turning the capstan by hand very slowly. Any deflection of the meter indicates an open armature.		
Always start with Seq 1 and follow the procedure in sequence unless directed otherwise. Remember to END all problem or maintenance calls by going to MAP 00-030.		
Seq	Condition/Instruction	Action
1	With the tape unit unloaded, power on and no field tester attached, is the capstan motor running?  <b>Note:</b> Refer to 6A-120 for a description of the capstan drive circuits.	Change T-A1G2, capstan board. Go to ALD FT351 for further analysis.
1A	Further testing is inconclusive unless you are sure the tachometer output is correct. Check the tach output as follows:  <ol style="list-style-type: none"> <li>Tape unit unloaded.</li> <li>Plug capstan motor into test socket on capstan motor control board.</li> <li>Scope setup: <ol style="list-style-type: none"> <li>+Squaring Circuit Pulses (ALD FT351) Probe T-A1G2G02</li> <li>Vertical = 1v/cm</li> <li>Horiz. = Mod 3 - 20 ms/cm Mod 5 - 10 ms/cm Mod 7 - 5 ms/cm</li> <li>Single Sweep</li> <li>Push scope RESET button repeatedly and compare waveform with Figures 1 and 2 on 6A-002.</li> </ol> </li> </ol>	
2	Is there a blank area or glitch indicating missing squaring circuit pulses?	<ol style="list-style-type: none"> <li>Clean tachochmeter disc and mirror.</li> <li>Check tach disc for damage and replace capstan motor if disc is damaged.</li> <li>Check capstan fiber optics bundle.</li> <li>Change tachometer block and optics bulb.</li> <li>Change T-A1G2.</li> </ol> Go to 00-030.

Seq	Condition/Instruction	Action
3	If not:	Perform the Capstan Tachometer Check/Adjustment (08-130). Return to Seq 4 after completing procedure.
4	Is problem fixed?	Go to 00-030.
5	<ol style="list-style-type: none"> <li>Remove the capstan plug from the test socket and plug it into the normal socket.</li> <li>Load tape normally.</li> <li>Attach the field tester and set up as follows: Go Alt Dir. Slow Read Both pots fully On (toward rear of tester)</li> </ol>	
6	Observe tape motion in stubby columns. Does the tape path vary from that shown on 6A-010 Figure 1 (normal)?	From Figures 2 through 5 on 6A-010, choose the one which most closely resembles the tape path observed. Oxide marks on the columns are further evidence of where the tape has been riding. Take the corrective action indicated beside the figure you choose.
7	Is the problem fixed?	Go to 00-030.
8	To check motor drag, set up the tape unit and scope as follows:  <ol style="list-style-type: none"> <li>Set field tester: <ol style="list-style-type: none"> <li>Read</li> <li>Forward</li> <li>Go</li> </ol> </li> <li>Scope Setup: <ol style="list-style-type: none"> <li>Sync (+) internal</li> <li>Probe T-A1G2P05 + Capstan Fast</li> <li>Horiz. = 0.2 ms/div</li> <li>Vert. = 1 v/cm</li> <li>Single Sweep</li> <li>Press scope RESET button repetitively.</li> </ol> </li> </ol> Compare scope trace with Figures 3, 4, and 5 on 6A-002 to determine status of duty cycle.	
9	Was the duty cycle ratio high?	Change in order:  <ol style="list-style-type: none"> <li>T-A1G2</li> <li>T-A1F2</li> </ol> If the ratio is still high, excessive tape path drag is the next most probable cause. Go to Seq 18.

Seq	Condition/Instruction	Action
10	Check capstan speed under start/stop mode of tape motion as follows:  <ol style="list-style-type: none"> <li>Set field tester: <ol style="list-style-type: none"> <li>St/Stp</li> <li>Fwd</li> <li>Fast</li> <li>Read</li> <li>Both pots fully off (toward front of tester)</li> </ol> </li> <li>Scope Setup: <ol style="list-style-type: none"> <li>Sync (+) internal</li> <li>Probe T-A1G2G02 (ALD FT351) +Squaring Circuit Pulses</li> <li>Vertical = 1v/cm</li> <li>Horiz. = Mod 3 - 20 us/cm Mod 5 - 10 us/cm Mod 7 - 5 us/cm</li> </ol> </li> </ol> Vary both tester pots throughout their range with tester set to Forward. Repeat with tester set to Backward. Scope should display a square wave (Figure 6, 6A-002) with duration of: For Mod 7 full wave = 47 us For Mod 5 full wave = 75 us For Mod 3 full wave = 125 us	
11	Is speed excessively (5%) high or low?	Change in order:  <ol style="list-style-type: none"> <li>T-A1G2</li> <li>T-A1F2</li> <li>Capstan motor board.</li> </ol> If not fixed, go to Seq 13.
12	If not:	Change T-A1L2. Go to 00-030.
13	Is speed still too high or low?	<ol style="list-style-type: none"> <li>Check for proper -48 Vdc to capstan motor control board (connectors, etc.).</li> <li>Check -48 Vdc capstan resistor in housing box (ALD ZT051). Values should be: M7=2 ohm 200W M5=4 ohm 100W M3=10 ohm 50W</li> <li>Replace capstan motor.</li> </ol>

3803-1,2,3/3420

<b>XB3000</b> Seq 1 of 2	<b>2735773</b> Part Number	<b>See EC History</b>	<b>845958</b> 1 Sep 79	<b>847298</b> 15 Aug 83			
-----------------------------	-------------------------------	-----------------------	---------------------------	----------------------------	--	--	--

© Copyright International Business Machines Corporation 1976, 1979, 1983

6A-000

Seq	Condition/Instruction	Action
14	<p>Check for momentary velocity changes in excess of 5% (overshoot).</p> <p>1. Set up field tester:</p> <ul style="list-style-type: none"> <li>a. Go</li> <li>b. Fwd</li> <li>c. Write</li> <li>d. 1600</li> </ul> <p>Mount a CE work tape and write a full reel. Rewind tape.</p> <p>2. Set up field tester:</p> <ul style="list-style-type: none"> <li>a. St/Stop</li> <li>b. Both pots full OFF (toward front of tester)</li> <li>c. Fast</li> <li>d. Read</li> <li>e. Fwd</li> </ul> <p>3. Scope Setup:</p> <ul style="list-style-type: none"> <li>a. Sync (-) internal</li> <li>b. Sync probe on T-A1F2D13 -Move</li> <li>c. Probe -P track on read card</li> <li>d. Vertical = 0.1 v/cm</li> <li>e. Horiz. =</li> </ul> <p style="margin-left: 40px;">Mod 7 - 2 ms/cm Mod 5 - 5 ms/cm Mod 3 - 5 ms/cm</p> <p>Compare waveform with Figures 7 and 8 on 6A-002.</p> <p><b>EXPLANATION:</b> A speed change will cause an amplitude change in the Read signal (see Figure 8 on 6A-002). Overshoot is caused by applying more power to the capstan motor than is normally required to get the tape up to speed. Overshoot is usually the result of too much drag in the tape path to smoothly accelerate the tape. Does the condition exhibited in Figure 8 exist?</p>	Go to Seq 8.
15	Go to Seq 16.	

Seq	Condition/Instruction	Action
16	<p>Check Write Inhibit for proper functioning.</p> <p>1. Set up field tester:</p> <ul style="list-style-type: none"> <li>a. St/Stop</li> <li>b. Fwd</li> <li>c. Fast</li> <li>d. Write</li> <li>e. 1600</li> <li>f. Both pots fully off (toward front of tester).</li> </ul> <p>As tape is being written, vary Go Up/Down throughout entire range of tester.</p> <p>While doing this, scope +Write Inhibit.</p> <p>2. Scope setup:</p> <ul style="list-style-type: none"> <li>a. Probe T-A1F2J10 +Write Inhibit.</li> <li>b. Sync internal minus</li> <li>c. Sync probe on T-A1F2J12 (+GO INT)</li> <li>d. Vert. = 1 v/cm</li> <li>e. Horiz. =</li> </ul> <p style="margin-left: 40px;">Mod 7 = 1 ms/cm Mod 5 = 1 ms/cm Mod 3 = 2 ms/cm</p> <p>f. 'Chop' mode</p> <p>Compare waveform with Figure 9 on 6A-002.</p>	
17	Does Write Inhibit look different from Figure 9?	Change T-A1F2. Go to 00-030.
18	Perform column vacuum level check. See 08-400. Was vacuum column out of specification?	Adjust vacuum column (see 08-410). Go to 00-030.

Seq	Condition/Instruction	Action
19	Check air pressure (see 08-400). Is air pressure out of specification?	Go to Seq 22.
20	Clean the air bearings and other components of the tape path. Is the trouble corrected?	Go to 00-030.
21	If not:	Go to Seq 25.
22	Is a three-way valve mounting stud broken? (See illustration.)	Repair and go to 00-030.
23	Is the pressure manifold loose? (See illustration.)	Repair and perform air pressure check. See Seq 19. Go to 00-030.
24	If not:	Refer to the diagram on 4A-161 to aid in checking for dirty filters, loose or defective hoses, or other components. Go to 00-030.
25	Is the vacuum column door loose or maladjusted? See 08-680.	Readjust or tighten door to obtain a good seal. Go to 00-030.
26	Is there excessive wear on the Read/Write head?	Worn heads sometimes exhibit a condition similar to overshoot, caused by tape flying too close to the head surface during tape acceleration. See Figure 8 on 6A-002. If certain that there is no tape drag or problem in the tape path, replace the R/W head. Go to 00-030.
27	Otherwise:	Clean the tape path, capstan, head, cleaner blade, columns, and all air bearings. Go to Seq 28.
28	Is the problem fixed?	Go to 00-030.
29	If not:	Recheck symptoms.

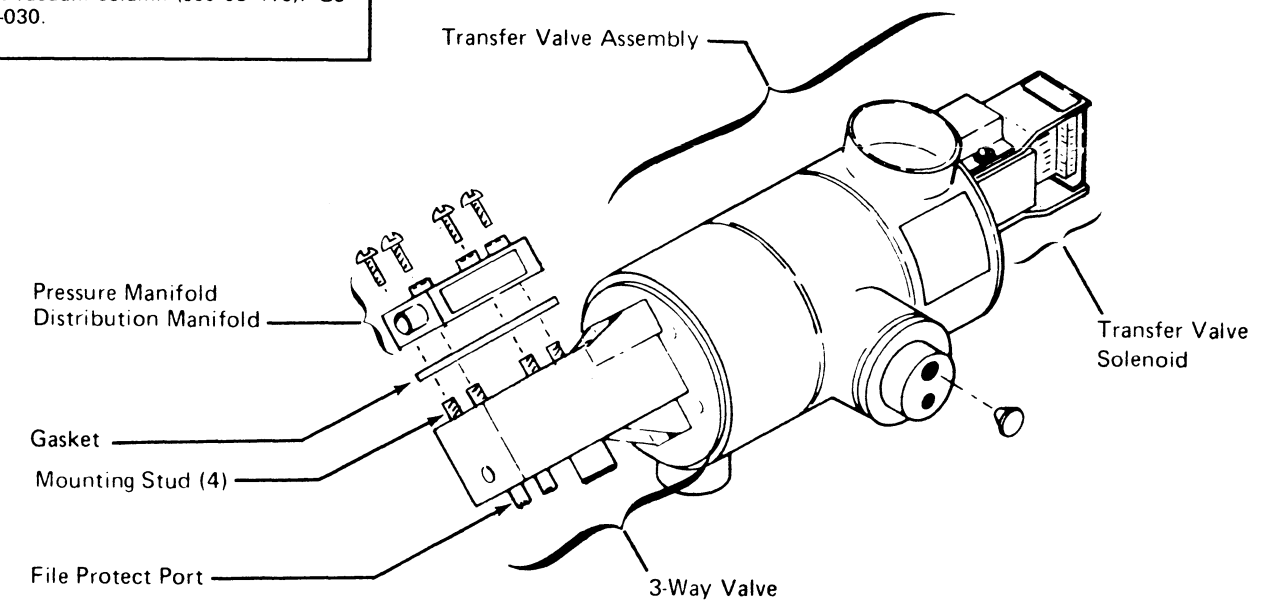

3803-1,2,3/3420

<b>XB3000</b>	<b>2735773</b>	<b>See EC History</b>	<b>845958</b>	<b>847298</b>				
Seq 2 of 2	Part Number		1 Sep 79	15 Aug 83				

© Copyright International Business Machines Corporation 1976, 1979, 1983

CAPSTAN MOTOR WAVEFORMS

6A-002

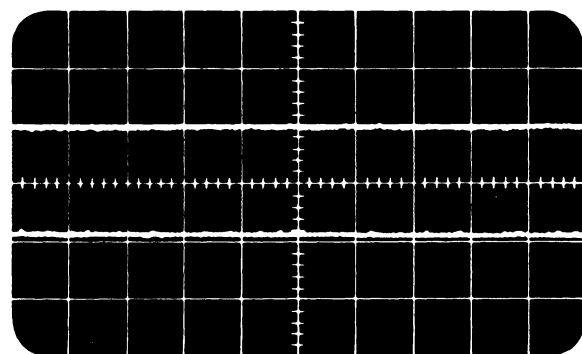

Figure 1

Proper continuous tachometer output.

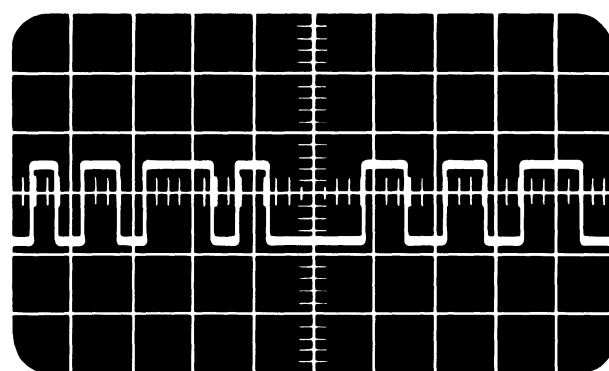

Figure 4

Marginal Duty Cycle (Up Coast, Down Drive)  
Predominately 1:2 tape drag causing marginal tape operation.

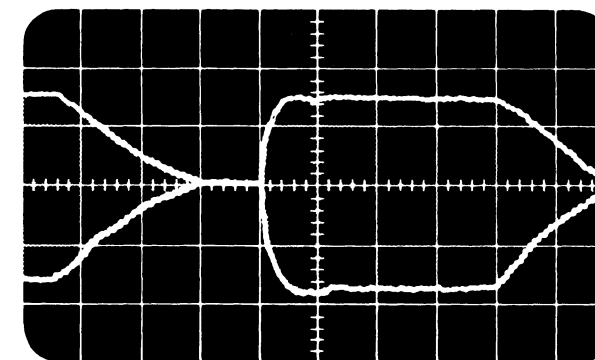
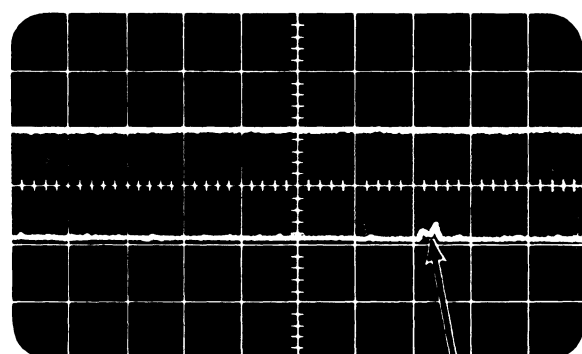

Figure 7

Normal Operation



GLITCH

Figure 2

Continuous tachometer output with a dirty capstan disc.

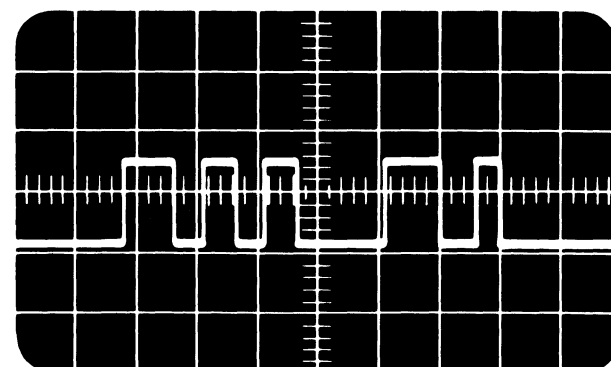

Figure 5

Failing Duty Cycle (Up Coast, Down Drive)  
Predominately 2:1 tape drag causing a failing tape operation.

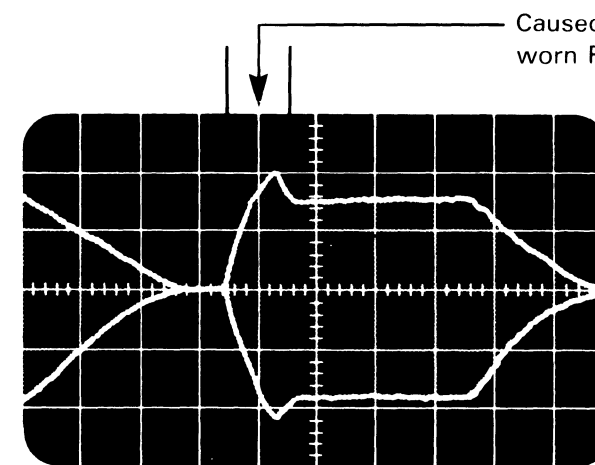

Figure 8

Marginal Operation

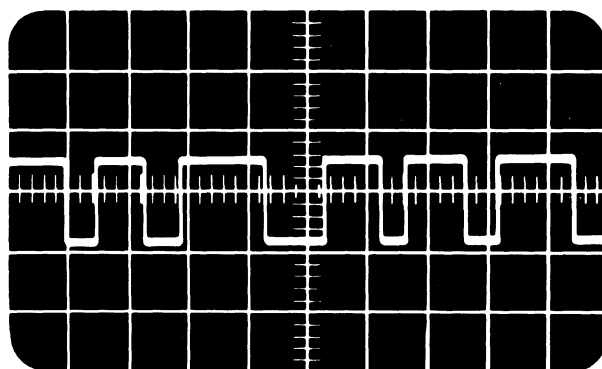

Figure 3

Good Duty Cycle (Up Coast, Down Drive)

Predominately 1 drive followed by 3 coast periods (1:3). One period is the time between 2 capstan pulses. Model 3 - 125 usec, Model 5 - 75 usec., Model 7 - 47 usec. An occasional 1:2 or 2:3 is normal.

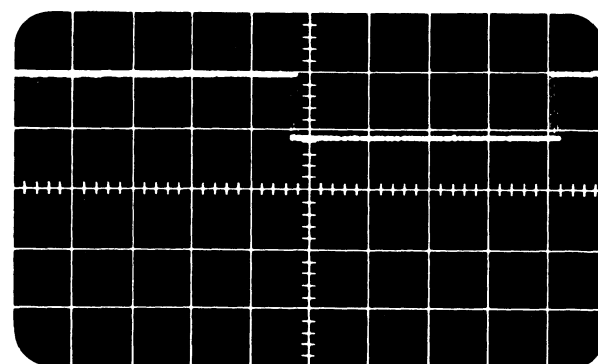

Figure 6

Tach period for model 7, duration is 47 microseconds.

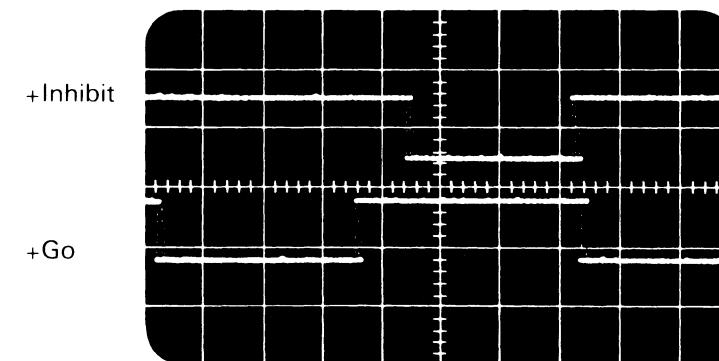

Figure 9

Note: +Inhibit goes plus at fall of Move.

+Go goes negative slightly after +Inhibit goes positive.

3803-1,2,3/3420

XB3100	2735774	See EC	845958	847298				
Seq 1 of 2	Part Number	History	1 Sep 79	15 Aug 83				

6A-002

NOTES:

6A-003

3803-1,2,3/3420

<b>XB3100</b> Seq 2 of 2	<b>2735774</b> Part Number	<b>See EC</b> <b>History</b>	<b>845958</b> 1 Sep 79	<b>847298</b> 15 Aug 83				
-----------------------------	-------------------------------	---------------------------------	---------------------------	----------------------------	--	--	--	--

© Copyright International Business Machines Corporation 1976, 1979, 1983

6A-003





## TAPE MOTION PROBLEMS (STUBBY COLUMN LOOPS)

6A-010

The tape loops in the stubby columns are normally in the position shown in Figure 1 while loaded and not moving or continuously moving forward or backward, or with the tester set up for Alt Dir with a long Go Up Time. Any variation in loop position beyond approximately 1/2 inch (12.7mm) indicates a pneumatic or tape drag problem. This condition can cause intermittent read/write errors or loading problems. The figures on this page provide a visual means to help identify abnormal tape motion and to associate the symptoms to failing components.

### PROCEDURE TO CHECK FOR PNEUMATIC IMBALANCE OR LEAKS

- Load tape unit with a CE scratch tape and as soon as the tape enters the columns push reset. If the tape is positioned like Figure 1 go to step B otherwise go to probable causes below.
- Use Field Tester and move tape well into a high speed area.
- While observing the stubby columns, rewind tape unit making sure the tape goes into a high speed rewind.
- Tape should be equally into the right and left stubby column in both a high and low speed rewind. See Figure 1.
- Observe tape in stubby columns as the tape unit goes from a high to a low speed rewind. Tape must not pull out of the stubby columns. See Figure 3.
- If tape is not equal or pulls out of a stubby column, a problem exists which could cause intermittent read or write problems.

#### Probable Causes

- Hoses kinked or not tight on the transfer valve or plenum.
- Capstan-to-stubby clearance to great. It should be 0.006 to 0.010 inch (0.15 to 0.25 mm). See 08-080.

- Vacuum column door glass to low causing a poor seal between glass and upper stubby bar. Push glass upward and check to see if tape positions itself properly. See Figure 1. Do adjustments on pages 08-690.
- Vacuum column door maladjusted. Apply pressure to glass in the stubby column area and see if tape positions itself like Figure 1. Do adjustment on page 08-680.
- Vacuum column door glass warped causing a poor seal between glass and stubby columns. If tape is unequal in the stubby columns, apply pressure to the glass in the area of the stubby columns and see if the tape pulls into the column as shown in Figure 1. If this is the indication and all other adjustments have been done, obtain a long straight edge (18 inch minimum) and check for warpage by holding the straight edge on the inside of the glass in the area of the stubby columns. Replace the glass if the gap between the glass and the straight edge is greater than 0.005 inches (0.13mm).

### PROCEDURE TO CHECK FOR TAPE DRAG

- Set up Field Tester as follows:  
GO  
ALT DIR  
SLOW  
READ  
Put both potentiometers fully on (toward rear of tester).
- Observe the stubby columns and compare observation to figures. If stubby columns do not appear similar to Figure 1, refer to probable causes under figure most like actual observation.

Figure 1. Normal

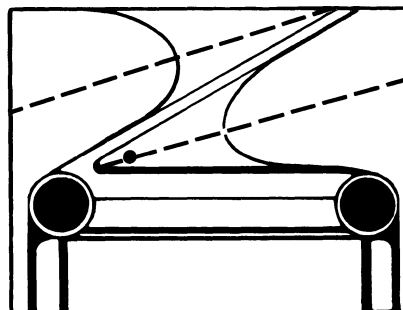

Figure 1 shows the normal position in the stubby columns. The tape should be in this position after the tape enters the columns on a load and it should maintain approximately this position during tape motion. A difference of 1/2 inch (12.7 mm) between forward and backward is normal. Measure this difference along an imaginary line referred to in Figure 1 by the dotted line.

Figure 2. Forward Continuous

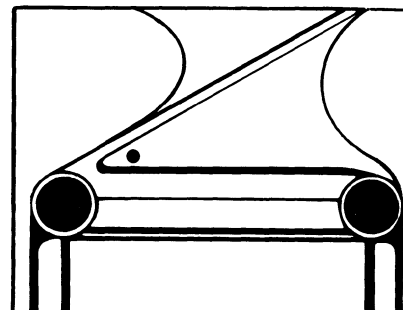

Figure 2 indicates a dirty (plugged) right air bearing, low air bearing pressure, high vacuum, or improper vacuum door glass to column seal.

Figure 3. Backward Continuous

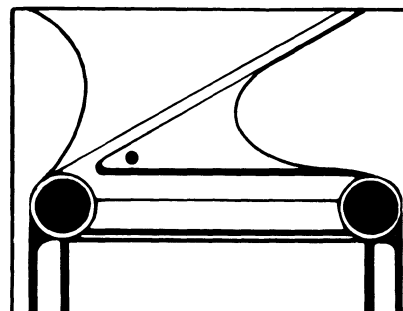

Figure 3 indicates a dirty (plugged) left air bearing, low air bearing pressure, high vacuum, or improper vacuum door glass to column seal.

Figure 4. Forward Continuous

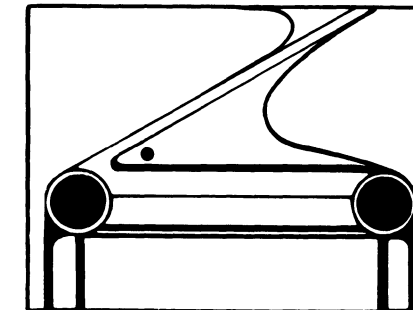

Figure 4 indicates a dirty (plugged) left air bearing or worn left stubby column glass bead tape.

Figure 5. Backward Continuous

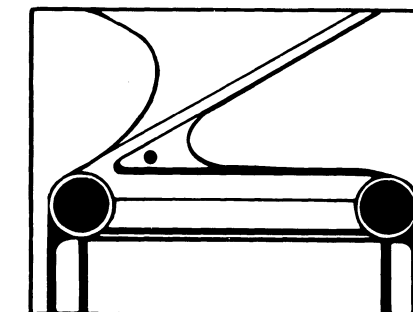

Figure 5 indicates a dirty (plugged) right air bearing or worn right stubby column glass bead tape.

3803-1,2,3/3420

XB3200	2735775	See EC	845958	846927			
Seq 1 of 2	Part Number	History	1 Sep 79	20 Jun 80			

© Copyright International Business Machines Corporation 1976, 1979, 1980

6A-010

NOTES:

6A-100

3803-1,2,3/3420

<b>XB3200</b> Seq 2 of 2	<b>2735775</b> Part Number	<b>See EC</b> <b>History</b>	<b>845958</b> 1 Sep 79	<b>846927</b> 20 Jun 80				
-----------------------------	-------------------------------	---------------------------------	---------------------------	----------------------------	--	--	--	--

© Copyright International Business Machines Corporation 1976, 1979, 1980

6A-100



# CAPSTAN DRIVE SYSTEM, MODELS 3, 5, and 7

The capstan drive system moves tape past the read/write head. A constant speed is maintained during read and write type operations and slow speed rewind. The maximum speed is maintained during high speed rewind.

This diagram shows the major components of the capstan drive system and lists their functions.

### CAPSTAN CONTROL CIRCUITS

- Capstan control circuits compare capstan pulses to reference timings generated by 2 MHz oscillator pulses.
- If the interval between two successive capstan pulses is less than the time it takes the capstan control counter to overflow, the capstan is running fast.
- If a capstan control counter overflow occurs before a second capstan pulse arrives, the capstan is running slow.
- The capstan driver logic uses the status of the Fast/Not Fast line to determine whether the capstan should accelerate or coast.

### CAPSTAN PULSE GENERATION

- The capstan tachometer includes a fiber optic light source, an etched mirror on the capstan disk face, an interrupter mask, a phototransistor, and capstan pulse squaring circuits.
- Pulses are generated by light reflected from the turning mirror surface on the capstan disk face.
- The capstan squaring circuit pulses activate two singleshots whose output (capstan A and B pulses) is used by capstan control circuits.

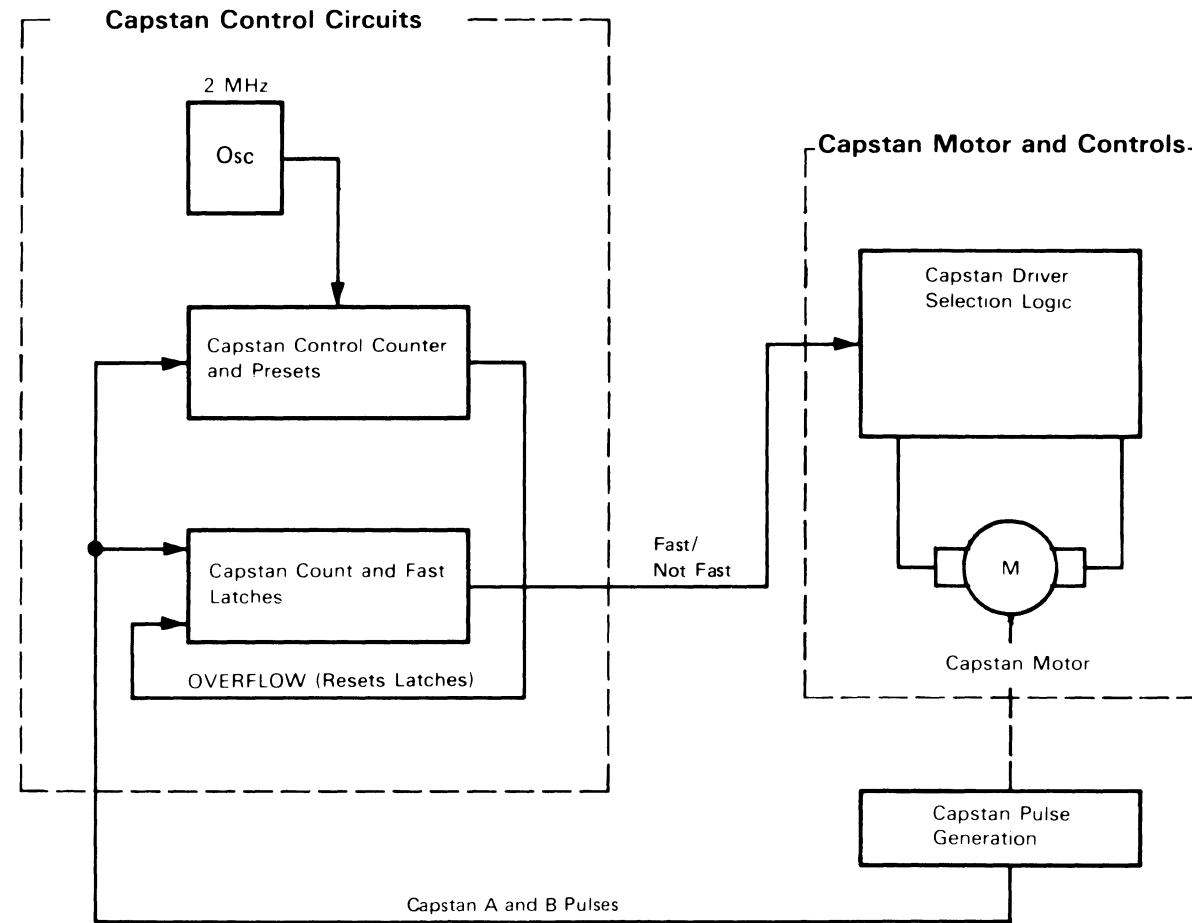

### CAPSTAN MOTOR AND CONTROLS

- The capstan motor is a high-torque, low-inertia, vacuum-cooled dc motor which starts and stops quickly.
- A single, rubber-coated capstan drives tape in either direction.
- Lines etched in the mirrored face of the capstan are used to generate pulses which measure capstan travel.
- Capstan drivers control direction and magnitude of the armature current, according to the operation being performed.
- The capstan motor has a permanent magnetic field.
- Varying the current through the armature controls capstan motor speed.
- The direction of current through the armature controls the capstan motor direction.
- Grounding both sides of the capstan motor armature causes braking.

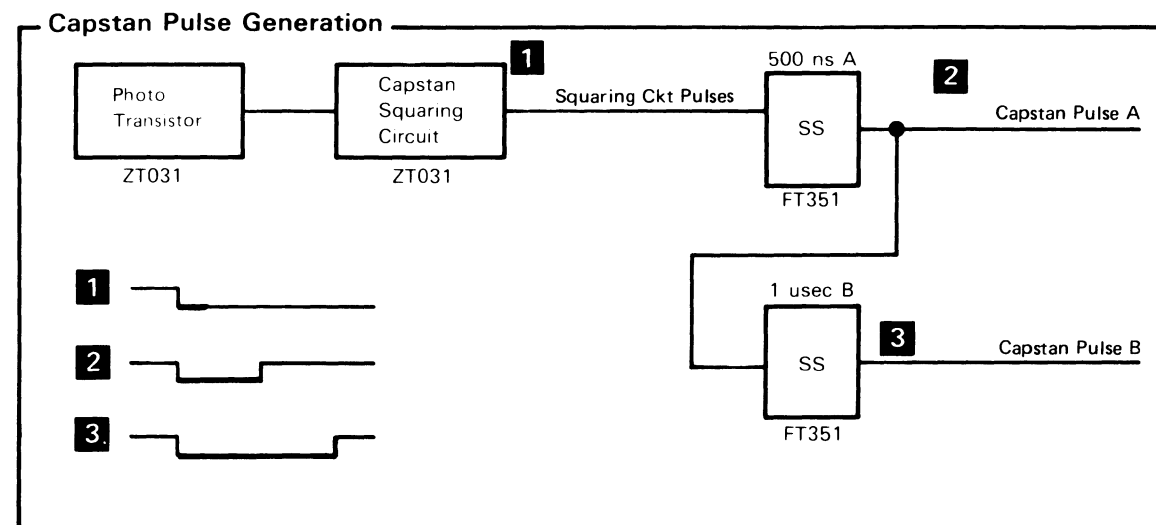

3803-1,2,3/3420

<b>XB3300</b> Seq 1 of 2	<b>2735776</b> Part Number	<b>See EC History</b>	<b>845958</b> 1 Sep 79				
-----------------------------	-------------------------------	-----------------------	---------------------------	--	--	--	--

# IBG COUNTER MODELS 3, 5, AND 7

The interblock gap (IBG) counter is a seven-stage binary counter.

During Threading operations (tape unit Manual Status line active), the IBG counter monitors tape progress by counting machine reel revolutions. A light source, two reflective markers on the machine reel, and a phototransistor generate counter drive pulses.

During a Write operation, the IBG counter monitors the length of interblock gaps. In this application, gated capstan pulses step the counter. An IBG count of 48 plus the distance between the read and write gap (16 capstan pulses) corresponds to a 0.6 inch (15.2mm) IBG.

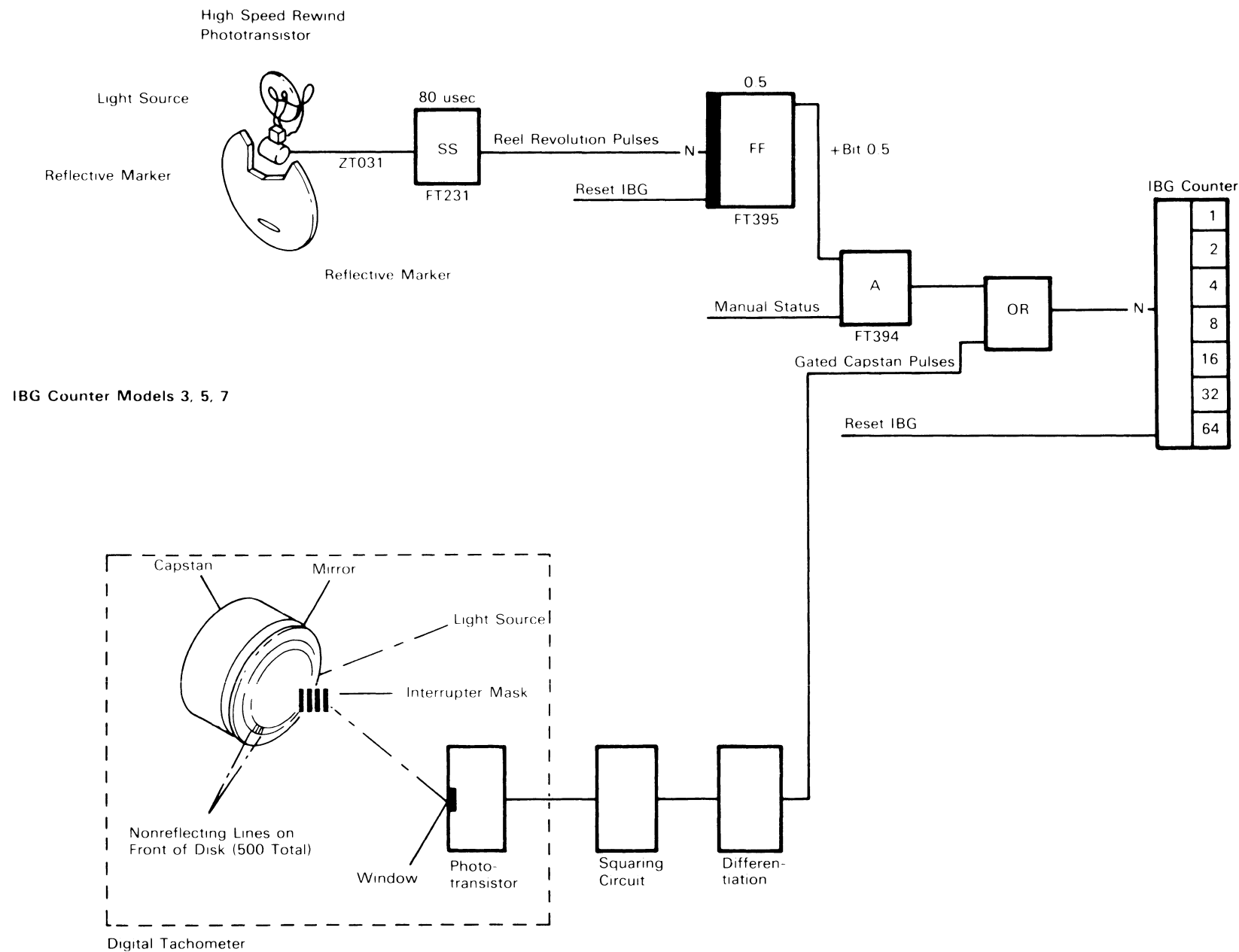

3803-1,2,3/3420

<b>XB3300</b> Seq 2 of 2	<b>2735776</b> Part Number	<b>See EC History</b>	<b>845958</b> 1 Sep 79						
-----------------------------	-------------------------------	-----------------------	---------------------------	--	--	--	--	--	--

© Copyright International Business Machines Corporation 1976, 1979



# GO EXTEND IBG COUNTS MODELS 3, 5, AND 7

Go Extend is a function of the tape unit that reduces data access time. After the tape control deactivates the Move tag to the tape unit, Go Extend is activated to move tape far enough into the interblock gap (IBG) so only the amount of tape necessary to attain operating speed is moved to start the next operation.

The IBG count at which Go Extended is deactivated varies with models.

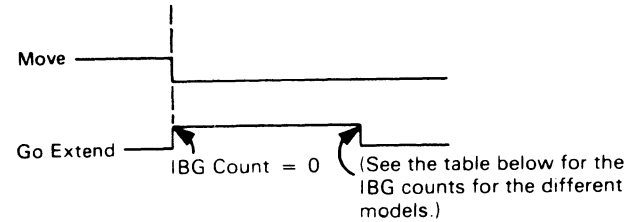

	Nine Track		Seven Track	
	Write	Read	Write	Read
Model 3	16	32	32	48
Model 5	4	20	20	36
Model 7	6	10	22	26

### Additional Stopping Distances After Go Extend

Model 3	9 to 17
Model 5	17 to 27
Model 7	14 to 24 (with plugging)
Model 7	28 to 38 (without plugging)

### PLUGGING (MODEL 7 ONLY)

To allow the Model 7 time to reach correct operating speed by the time the IBG is generated, special stopping action called "plugging" is used only at the end of a Write operation. Plugging applies reverse high power drive current to the capstan motor to position tape in the IBG. High Power Drive is activated two IBG counts after Go Internal is deactivated. The direction of the drive current produces backward motion. The plugging continues until the capstan counter overflows. In this situation, the capstan counter is not preset and overflows at a count of 256. The capstan is moving tape at approximately 73 inches per second when overflow occurs.

### Model 7



3803-1,2,3/3420

<b>XB3400</b>	<b>2735777</b>	<b>See EC</b>	<b>845958</b>	<b>847298</b>				
Seq 1 of 2	Part Number	History	1 Sep 79	15 Aug 83				

© Copyright International Business Machines Corporation 1976, 1979, 1983

# INTERBLOCK GAP (IBG) GENERATION

The length of an IBG is determined by counting Capstan Tach pulses from the time the last byte in a block is read—checked until writing commences for the next block. When generating a normal, 0.6-inch IBG on a 9-track tape unit the IBG count is 48, while the IBG count is 64 when generating an 0.75-inch IBG on a 7-track unit. After the end of a block, when the fortieth zero or the longitudinal redundancy check (LRC) character is written, Move remains active until the last byte is read at the read head. Tape motion required to move the last byte from the write gap to the read gap generates the first 0.150 inch (3.81 mm) of the IBG.

When Move is deactivated, the IBG counter counts gated capstan pulses until tape stops. At this point, the IBG count varies among models; it depends on Go Extend and Capstan Plugging. A nine-track Model 5 tape unit stops with an IBG count of about 26.

The remainder of the IBG is generated at the start of the next write operation. Before the next block is written, the IBG counter must have reached 48 (9-track) or 64 (7-track) and tape must be up to speed. Tape speed is monitored by the tape control. If tape is not up to speed at IBG count 48, the capstan keeps accelerating and its velocity is checked again at every fourth IBG count until the counter reaches 68.

If the capstan isn't up to speed by IBG count 68, the tape control sets Velocity Check and terminates the write operation.

For a seven-track tape unit, the tape control starts writing at IBG 64 because of the larger gap.

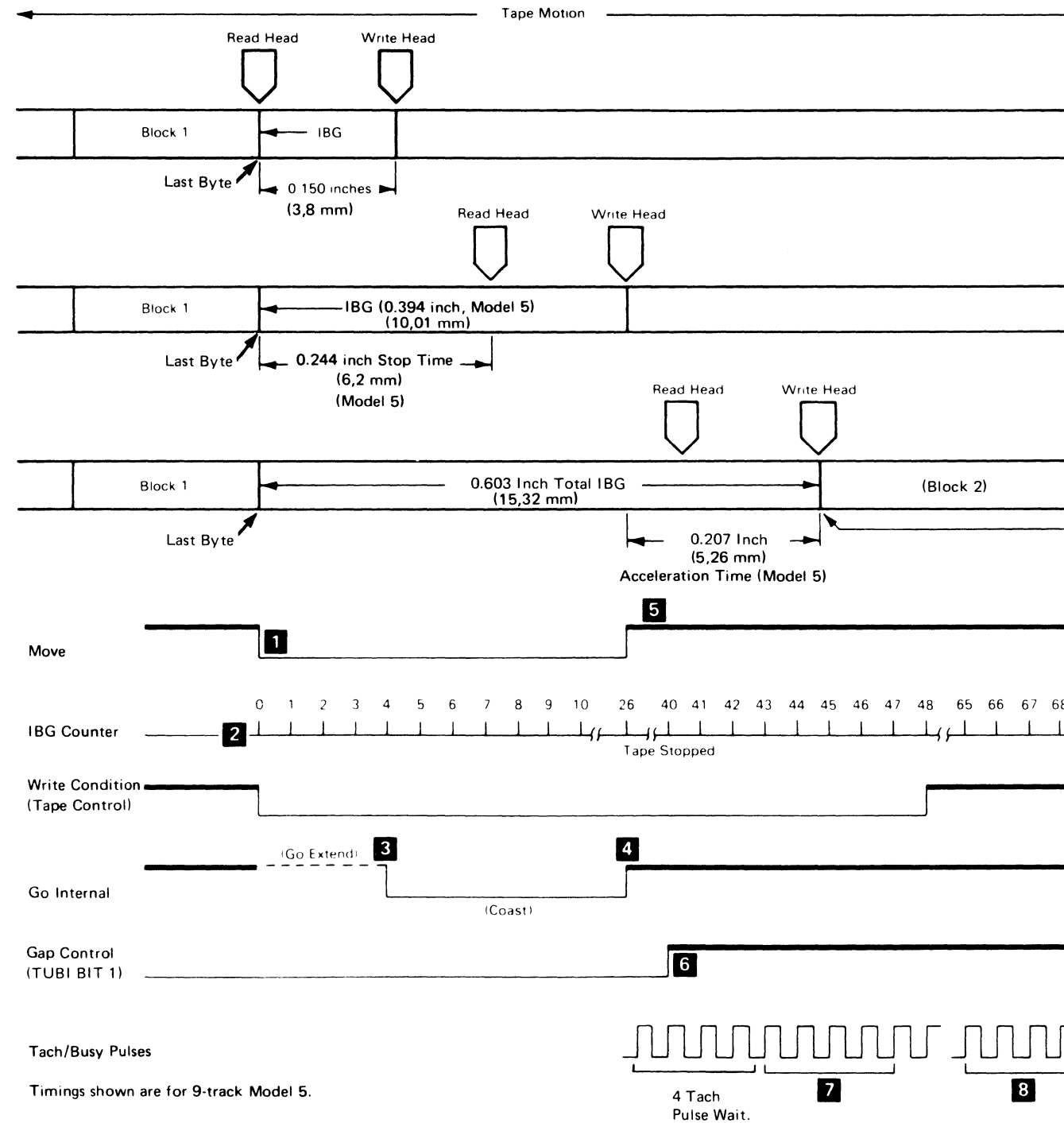

1. Tape position when MOVE drops for block 1.
2. Tape position when tape stops (Mod 5).
3. Tape position when writing commences for block 2.

- 1 Drop Write Condition and Move when end of block is past the read head.
- 2 Step the IBG counter with capstan tach pulses after Move drops.
- 3 Hold Go Internal active (via Go Extend) until IBG count 4.
- 4 Tape coasts to a stop at about IBG count 26.
- 5 Resume tape motion and continue stepping the IBG counter.
- 6 Activate Gap Control and generate TUBI bit 1 if Command tag is active.
- 7 Tape control monitors Tach/Busy pulses. If spacing (tape speed) is correct, set Write Condition and start the Write Clock in the tape control. If spacing is incorrect, set Velocity Retry and sense byte 8, bit 7 in the tape control, and continue monitoring the Tach/Busy line for correct speed.
- 8 Check speed (spacing) of next four pulses. If correct, set Write Condition and start the Write Clock. If not up to speed by IBG count 68, set Velocity Check and sense byte 10, bit 7, in the tape control and terminates the write operation.

3803-1,2,3/3420							
XB3400	2735777	See EC	845958	847298			
Seq 2 of 2	Part Number	History	1 Sep 79	15 Aug 83			

© Copyright International Business Machines Corporation 1976, 1979, 1983



COMMAND OR CONTROL STATUS REJECT

From 00-040, 16-160, 16-210		
<b>ERROR DESCRIPTION:</b> These errors usually are set when either the Command or the Control tag is sent to the tape unit, and the tape unit responds with the incorrect status byte on tape unit Bus In. (If Set Pulse occurs, tape unit Interrupt In is sampled instead of tape unit Bus In). The status byte is put in Sense Byte 23 if a failure occurs.		
<b>Most Probable Causes:</b>		
<ol style="list-style-type: none"> <li>1. T-A1K4, T-A1H2 defective.</li> <li>2. T-A1J2, T-A1L2 defective.</li> <li>3. T-A1L6 defective.</li> <li>4. T-A1K2 (NRZI only) defective.</li> <li>5. Erase Head defective.</li> <li>6. Write card or cable (if invalid write status only) defective.</li> </ol>		
Always start with Seq 1 and follow the procedure in sequence unless directed otherwise. Remember to END all problem or maintenance calls by going to MAP 00-030.		
Seq	Condition/Instruction	Action
1	Is tape control available?	<ol style="list-style-type: none"> <li>1. Load and Ready tape unit (failing TU if known) with a scratch tape.</li> <li>2. Enter failing command, if known, from chart 3 on 6A-161; otherwise, step through all commands in chart 3, page 6A-161.</li> <li>3. Set the Cmpr Register to the ALU2 stop address specified in chart 3, page 6A-161, for the command being executed.</li> <li>4. Set ALU1/ALU2 switch to ALU2.</li> <li>5. Set Display Select switch to IC.</li> <li>6. Set ROS mode to Stop.</li> <li>7. Operate Command Control Start switch once. (IC should now indicate the desired stop address.)</li> <li>8. Set Display Select switch to Bus In.</li> </ol> Go to Seq 3.

Seq	Condition/Instruction	Action																																																								
2	If not:	<ol style="list-style-type: none"> <li>1. Switch tape unit Offline.</li> <li>2. Remove tape unit interface signal cable to prevent invalid responses to tape control.</li> <li>3. Switch tape unit Online (allows scoping of Bus In drivers).</li> <li>4. Load tape unit with a scratch tape and press RESET after columns are loaded but before tape reaches load point.</li> <li>5. Make tape unit Ready.</li> <li>6. Disconnect capstan motor plug.</li> <li>7. Using Chart 3, (6A-161) find the proper tag and Bus Out assignments for the failing command (if failing command is not known, try all combinations on the chart).</li> <li>8. Tie up the appropriate tag and Bus Out pin to ground (D08):</li> </ol> <table border="0"> <tr> <td><b>TUBO</b></td> <td><b>Tape Unit</b></td> <td></td> </tr> <tr> <td>Cntl. tag</td> <td>T-A1K4D04,</td> <td>FT102</td> </tr> <tr> <td>Cmdn. tag</td> <td>T-A1K4J12,</td> <td>FT102</td> </tr> <tr> <td>Bus Out 0</td> <td>T-A1K4G03,</td> <td>FT101</td> </tr> <tr> <td>Bus Out 1</td> <td>T-A1K4G04,</td> <td>FT101</td> </tr> <tr> <td>Bus Out 2</td> <td>T-A1K4G05,</td> <td>FT101</td> </tr> <tr> <td>Bus Out 3</td> <td>T-A1K4G07,</td> <td>FT101</td> </tr> <tr> <td>Bus Out 4</td> <td>T-A1K4G08,</td> <td>FT101</td> </tr> <tr> <td>Bus Out 5</td> <td>T-A1K4G09,</td> <td>FT102</td> </tr> <tr> <td>Bus Out 6</td> <td>T-A1K4G10,</td> <td>FT102</td> </tr> <tr> <td>Bus Out 7</td> <td>T-A1K4J11,</td> <td>FT102</td> </tr> </table> <ol style="list-style-type: none"> <li>9. Determine from chart, on 6A-161, the appropriate output response and scope:           <table border="0"> <tr> <td><b>TUBI</b></td> <td><b>Tape Unit</b></td> <td></td> </tr> <tr> <td>-Bus In 0</td> <td>T-A1L2D02</td> <td rowspan="7">} FT146</td> </tr> <tr> <td>-Bus In 1</td> <td>T-A1L2D04</td> </tr> <tr> <td>-Bus In 2</td> <td>T-A1L2D05</td> </tr> <tr> <td>-Bus In 3</td> <td>T-A1L2D06</td> </tr> <tr> <td>-Bus In 4</td> <td>T-A1L2D07</td> </tr> <tr> <td>-Bus In 5</td> <td>T-A1L2D09</td> </tr> <tr> <td>-Bus In 6</td> <td>T-A1L2D10</td> </tr> <tr> <td>-Bus In 7</td> <td>T-A1L2D11</td> <td rowspan="2">} FT141</td> </tr> <tr> <td>-Interrupt In*</td> <td>T-A1L2B05</td> </tr> </table> </li> <li>10. Upon completion of this analysis:           <ol style="list-style-type: none"> <li>a. Reconnect capstan motor plug.</li> <li>b. Switch tape unit Offline.</li> <li>c. Reconnect tape unit interface signal cable.</li> <li>d. Switch tape unit Online.</li> </ol> </li> </ol> <p>* This line is not terminated and should have pulses with very little amplitude near the 0v reference. It may be necessary to tie up to ground (D08), Interrupt 1 (T-A1J2S10) to allow checking of the pulsing interrupt line. Go to 00-030.</p>	<b>TUBO</b>	<b>Tape Unit</b>		Cntl. tag	T-A1K4D04,	FT102	Cmdn. tag	T-A1K4J12,	FT102	Bus Out 0	T-A1K4G03,	FT101	Bus Out 1	T-A1K4G04,	FT101	Bus Out 2	T-A1K4G05,	FT101	Bus Out 3	T-A1K4G07,	FT101	Bus Out 4	T-A1K4G08,	FT101	Bus Out 5	T-A1K4G09,	FT102	Bus Out 6	T-A1K4G10,	FT102	Bus Out 7	T-A1K4J11,	FT102	<b>TUBI</b>	<b>Tape Unit</b>		-Bus In 0	T-A1L2D02	} FT146	-Bus In 1	T-A1L2D04	-Bus In 2	T-A1L2D05	-Bus In 3	T-A1L2D06	-Bus In 4	T-A1L2D07	-Bus In 5	T-A1L2D09	-Bus In 6	T-A1L2D10	-Bus In 7	T-A1L2D11	} FT141	-Interrupt In*	T-A1L2B05
<b>TUBO</b>	<b>Tape Unit</b>																																																									
Cntl. tag	T-A1K4D04,	FT102																																																								
Cmdn. tag	T-A1K4J12,	FT102																																																								
Bus Out 0	T-A1K4G03,	FT101																																																								
Bus Out 1	T-A1K4G04,	FT101																																																								
Bus Out 2	T-A1K4G05,	FT101																																																								
Bus Out 3	T-A1K4G07,	FT101																																																								
Bus Out 4	T-A1K4G08,	FT101																																																								
Bus Out 5	T-A1K4G09,	FT102																																																								
Bus Out 6	T-A1K4G10,	FT102																																																								
Bus Out 7	T-A1K4J11,	FT102																																																								
<b>TUBI</b>	<b>Tape Unit</b>																																																									
-Bus In 0	T-A1L2D02	} FT146																																																								
-Bus In 1	T-A1L2D04																																																									
-Bus In 2	T-A1L2D05																																																									
-Bus In 3	T-A1L2D06																																																									
-Bus In 4	T-A1L2D07																																																									
-Bus In 5	T-A1L2D09																																																									
-Bus In 6	T-A1L2D10																																																									
-Bus In 7	T-A1L2D11	} FT141																																																								
-Interrupt In*	T-A1L2B05																																																									

Seq	Condition/Instruction	Action
3	Do the tape unit Bus In indicators agree with Chart 3 on 6A-161 for the command being executed? See Note 4 on 6A-161.	Insert new command and repeat Seq 3.
4	Scope the tape unit Bus Out and Tag lines at the tape unit (see Seq 2 for the test points). Are they correct?	Go to Seq 6.
5	If not:	Check T-A1N4 cable. Go to 00-030.
6	Scope tape unit Bus In lines (see Seq 2 for test points). Are they correct? See Note 4 on 6A-161.	Check T-A1N2 cable. Go to 00-030.
7	If not:	1. For further analysis go to tape unit logic ALD FT146 (Bus In) and ALD FT141 (Interrupt In). If set pulse failure, go to ALD FT141.

3803-1,2,3/3420

<b>XB3500</b>	<b>2736061</b>	<b>See EC</b>	<b>845958</b>				
Seq 1 of 2	Part Number	History	1 Sep 79				

Chart 1

TU Bus Out Assignments

Bit	Cmnd. Tag On	Cntl. Tag On
0	Set Backward Read	Set Rewind Unload
1	Set Forward Read	
2	Set Diagnostic Mode	
3	Set Pulsing Interrupt	Set NRZI Mode
4	Set Write Status	
5		Set Data Security Erase
6	Reset [6]	
7		Set Rewind

Chart 2

TU Bus In Assignments

Bit	Cmnd. Tag On	Cntl. Tag On
0	Backward Status	Rewind Unload Set
1	Gap Control [7]	
2	Diagnostic Mode	
3		NRZI Mode
4	Write Status	
5		Data Security Erase
6	Unit Check [7] [8]	
7		Rewind Set

Chart 3

Tag and Bus Summary Chart

Command	Hex Cmnd.	ALU2 Stop	Cmnd. Tag	Cntl. Tag	TU Bus Out	TU Bus In
Write	01	170	On	Off	08	08
Write Tape Mark	1F	170	On	Off	08	08
Erase Gap	17	170	On	Off	08	08
Read Forward	02	170	On	Off	40	00
Forward Space Block	37	170	On	Off	40	00
Forward Space File	3F	170	On	Off	40	00
Read Backward	0C	170	On	Off	80	80
Backspace Block	27	170	On	Off	80	80
Backspace File	2F	170	On	Off	80	80
Rewind	07	170	Off	On	01	01
Rewind Unload	0F	170	Off	On	80	80
NRZI Mode Set	CB [1]	534	Off	On	10	10
Data Security Erase [2]	97	170	Off	On	04	04
Set Pulse	[3]	122	On	Off	10	[4]
Loop Write to Read	8B	170	On	Off	20	20 [5]

See Chart 1      See Chart 2

Notes:

- [1] a. A Mode Set of Hex CB is issued to a dual density tape unit for either a Write operation at load point or for a Read operation initiated at load point in which no PE ID burst is recognized.  
b. To test the tape unit statically, enter a Mode Set, Hex CB, followed by a Write, Hex 01. Set Mple/Single switch to Mple.  
c. If in ROS stop mode, the tape unit runs away if the Mode Set was issued after the Move tag was activated. Reset the tape unit and troubleshoot statically.
- [2] To execute a Data Security Erase and ROS stop for this test (if desired), go to 12-013.
- [3] a. This command is sent to a tape unit after an Unload Rewind is initiated or if a Start I/O is issued to a Not Ready tape unit in which the Interrupt In line is not previously pulsing. To test statically, enter an Unload/Rewind command, Hex 0F.  
b. If an Unload/Rewind is executed and ROS is set to Stop, the tape unit executes the operation.
- [4] On Set Pulse commands, the tape control samples the tape unit Interrupt In line instead of Bus In. See logic, ALD FT141. Ensure the Interrupt In line has a symmetrical square wave with a cycle width of approximately 500 ns.
- [5] Ensure tape unit Bus In Bit 2 is active. Other bits may or may not be active.
- [6] The tape control does not require any response from the tape unit for a Reset command. Therefore, no Command Status Reject can be set.
- [7] These conditions are not a direct result of either command or control tags.
- [8] If active, troubleshoot first. See logic, ALD FT114.

3803-1.2,3/3420

<b>XB3500</b> Seq 2 of 2	<b>2736061</b> Part Number	<b>See EC History</b>	<b>845958</b> 1 Sep 79					
-----------------------------	-------------------------------	-----------------------	---------------------------	--	--	--	--	--

© Copyright International Business Machines Corporation 1976, 1979





**3420 POWER SUPPLIES**

Each tape unit has its own self-contained power supply, and receives its input power from the tape control. A three-phase, 15-amp circuit breaker protects the line voltage to each tape unit.

A 60-Hz machine requires 200, 208, or 230 volts, while 50-Hz machines use 200, 220, 235, 380, or 408 volts.

**Caution:** There are two types of fuse holders in the field. The first type of fuse holder has the spring in the cap and the second type has the spring in the body. If the cap of the second type is placed on the body of the first type no spring tension will be on the fuse causing intermittent contact.

**IF THE CAP OF THE FIRST TYPE IS PLACED ON THE BODY OF THE SECOND TYPE A SAFETY HAZARD WILL EXIST DUE TO EXPOSED METAL WHICH WILL HAVE A POTENTIAL ON IT.**

**3420 AIRFLOW AND VOLTAGE MONITORING SYSTEM**

A mercury switch mounted on a movable air vane in the capstan control board plenum **B** monitors the cooling system airflow. If sufficient air is moving through the plenum, the vane moves, closing the switch. If the switch opens, or does not close, the tape unit activates the Power Check indicator lamp.

The same system monitors dc voltages. If any voltage becomes out of tolerance, the output of Loss Of Air Over Voltage/Under Voltage (OV/UV) detector activates the Power Check indicator. This output also activates the AO OV/UV latch and sets sense byte 18, bit 0.

**Note 1:** The -48 V power supply voltage should be a minimum of -47 V with the machine loaded and ready with no tape motion. If the voltage is low, suspect the SCR's in the -48 V supply. Check the SCR's by removing the SCR control card. There should be a 4 V loss with the card removed.

**Note 2:** Following the problem determination and repair, final power supply checks and/or adjustments should be made according to the directions included on MLM page 08-570.

**FILE PROTECT INDICATOR OFF OR POWER CHECK INDICATOR ON**

Always start with Seq 1 and follow the procedure in sequence unless directed otherwise. Remember to END all problems or maintenance calls by going to MAP 00-030.		
Seq	Condition/Instruction	Action
1	Does this unit have a modified power supply? <b>A</b>	Go to Seq 35.
2	Check rear of unit. Is F10, F11, F12, or F13 blown?	Go to Seq 18.
3	Check rear of unit. Is CP1, CP2, or CP3 (or CP4-50 Hz only) tripped?	Check components using ALD YF020/5 and YF030/5. Go to 00-030.
4	Check front of unit. Is F5, F6, F7, or F14 blown, or is CP5 tripped?	Go to Seq 23.
4A	Check that all voltages are present.	See Seq 11.
5	Is File Protect indicator On?	Go to Seq 7.
6	If not:	Most probable causes: 1. Defective File Protect lamp or socket. 2. Defective File Protect switch. 3. Binding File Protect plunger. 4. Defective Write Enable relay card. (Located below right reel motor). 5. Defective card T-A1M2. Go to ALD ZT071 for further analysis.
7	Is the cooling blower operating?	Go to Seq 9.
8	If not:	Refer to ALD YF030/5. Repair or replace as required.
9	Is there sufficient airflow at the logic gate? Compare to another drive, if necessary.	Go to Seq 11.
10	If not:	Check the air filter, hoses, ducts, blower motor, fan blades, and motor direction.

Seq	Condition/Instruction	Action			
11	Are the voltages out of specification? Ripple specification for -4 Vdc and +6 Vdc is 24 mvdc peak-to-peak. Measure at the power supply TB's located in the front of the machine. See 1B-002 for location.	Adjust, replace or repair the regulator cards and/or interface board as necessary (only +6 Vdc and -4.05 Vdc power supplies are regulated). See ALD YF020/5 to locate these cards.			
			<b>Value</b>	<b>Test Point</b>	<b>Ground</b>
			+6V; ±0.1V	T-A1G2B11	T-A1G2D08
			-4.05V; ±0.05V	T-A1H1C09	T-A1G2D08
			-48V;	TB1-9	TB1-8
			+12V; +1.4-0.9V	TB2-1	TB2-4
12	Is the Power Check indicator still On?	Turn power off. Change the OV/UV reference voltage generator or the voltage monitor (vm) card. <b>C</b> (See 1B-002). Restore power. Go to Seq 14.			
			-12V; ±1.4V	TB2-5	TB2-7
			+11V; +1.7-1.1V	TB3-12	TB2-4
13	If not:	Go to 00-030.			

**Modified Power Supply**

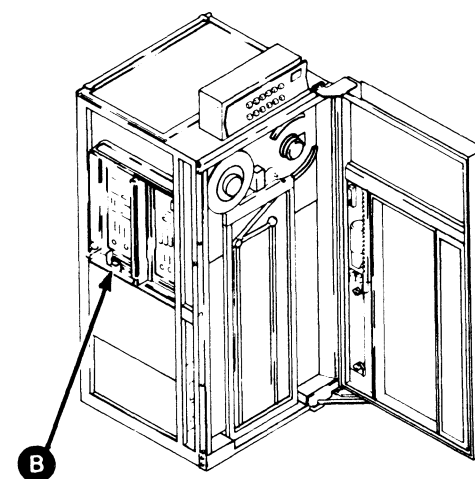
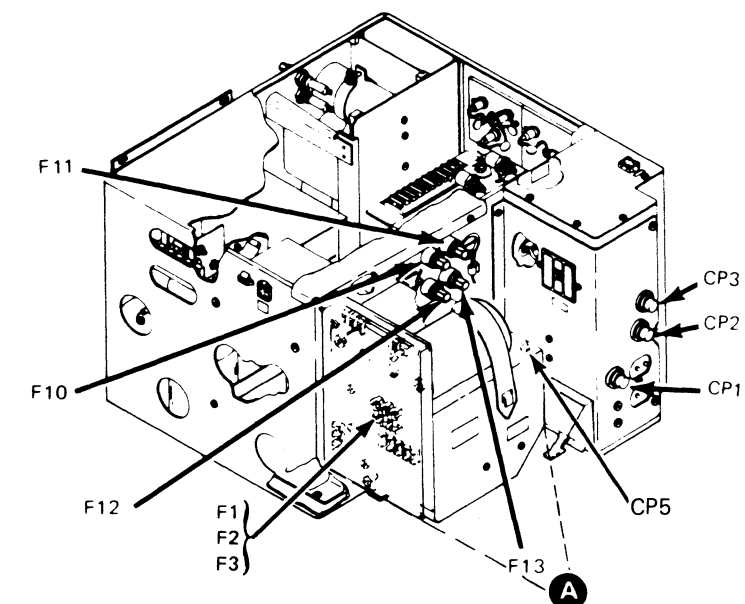

3803-2/3420

XC0100	2735778	See EC	845958	846927	847298		
Seq 1 of 2	Part Number	History	1 Sep 79	20 Jun 80	15 Aug 1983		

**FILE PROTECT INDICATOR OFF OR POWER CHECK INDICATOR ON (Cont'd)**

**1B-001**

Seq	Condition/Instruction	Action
14	Is the Power Check indicator still On?	Install a jumper from TB2-3 to TB2-8. See 1B-002 for TB locations. Go to Seq 16.
15	If not:	Go to 00-030.
16	Does the Power Check indicator go Off?	Remove the jumper. Most Probable Causes: 1. Mercury switch on the movable air vane <b>B</b> is defective. See 1B-000. 2. Insufficient air flow.
17	If not:	Remove the jumper and recheck the symptoms.
18	Turn power off. Replace the blown fuse. F10 8A medium blow (M4 and M6) 12A medium blow (M8) F11 8A medium blow F12, 13 10A medium blow (M4 and M6) 15A medium blow (M8) Restore power.	
19	Does the fuse blow again?	Replace the blown fuse and its corresponding FRU in the order listed below. To verify the fix, restore power and operate the tape unit. F10 1. Capstan power board 2. T-A1E2 (ALD FT301) 3. T-A1F2 (ALD FT335) 4. T-A1G2 (ALD FT323) 5. Capstan motor asm 6. Power window circuit F11 1. Left reel board 2. Right reel board F12 1. Right reel board 2. T-A1B2 (ALD FT45X) F13 1. Left reel board 2. T-A1B2 (ALD FT45X) Go to Seq 21.
20	If not:	Go to Seq 7.
21	Is problem fixed?	Go to 00-030.
22	If not:	Replace the power supply manual status control (MSC) card (ALD YF030/5). Go to 00-030.
23	Turn power off. Replace the blown fuse or reset CP5. F5 8A medium blow +12 Vdc F6 15A medium blow -12 Vdc F7 6A instantaneous 4.5 Vac F14 6A instantaneous +6 Vdc Restore power.	

Seq	Condition/Instruction	Action
24	Does the fuse blow or the circuit protector (CP) trip again?	Turn power off. Disconnect load to blown fuse at terminal board. See 1B-002 for TB location. Replace the blown fuse. F5 TB2-1; TB2-2 (gray wires) F6 TB2-5; TB2-6 (purple wires) F7 TB3-1 F14 TB3-3 CP5 TB3-2 (dc ground is TB1-8) Restore power. Go to Seq 26.
25	If not:	Go to Seq 7.
26	Does the fuse blow or CP trip again?	Go to Seq 29.
27	If not:	Turn power off. Measure from the removed wire(s) to ground and to other voltages for shorts. Repair as required. See ALD ZT031 for 4.5 Vac and ALD ZT051 for dc voltages.
28	Reconnect leads previously removed from the terminal board. Restore power and operate tape unit.	Go to 00-030.
29	Does F5, F6, or F7 blow? (See <b>B</b> on 1B-002.)	This is a wiring problem in the power supply—See ALD page YF020/5. Repair as required. Restore power. Go to 00-030.
30	Does F14 blow or is CP5 tripped?	Turn power off. Remove regulator card associated with fuse that has blown. See fuse specification in Seq 23 and ALD YF020/5. Replace fuse. Restore power.
31	Does F14 blow or CP5 trip again?	Turn power off. Check wiring from fuse to regulator card. Correct wiring problem and reinstall regulator cards previously removed. See ALD YF020/5. Restore power. If fixed, go to 00-030.
32	Install a new regulator card and adjust the voltage. See 08-570.	
33	Does fuse blow again?	Turn power off. Replace the associated capacitor and fuse. See ALD YF020/5. Restore power. Go to 00-030.
34	If not:	Go to 00-030.
35	This tape unit has a modified power supply.	
36	Check rear of unit. Is F10, F11, F12, or F13 blown?	Go to Seq 18.

Seq	Condition/Instruction	Action
37	Check rear of unit. Is F1 or F3 blown or CP6 tripped (located on modified power supply)? See 1B-000 for location of components. These are non-indicating fuses.	Go to Seq 53.
38	Check rear of unit. Is CP1, CP2, CP3, CP4, or CP5 tripped?	Check components using ALD YF010/5 for CP1, CP2 (Models 4, and 6 only), and CP3; ALD YF020/5 for CP4; ALD YF040/5 for CP5.
39	Check front of unit. Is F5, F6, or F7 blown? Notice that F8 and F9 are non-functional in 3420. Models 4 and 6.	Go to Seq 53.
39A	Check that all voltages are present. See Seq 46.	
40	Is File Protect indicator On?	Go to Seq 42.

**Modified 3420 Power Interface Board, B1**

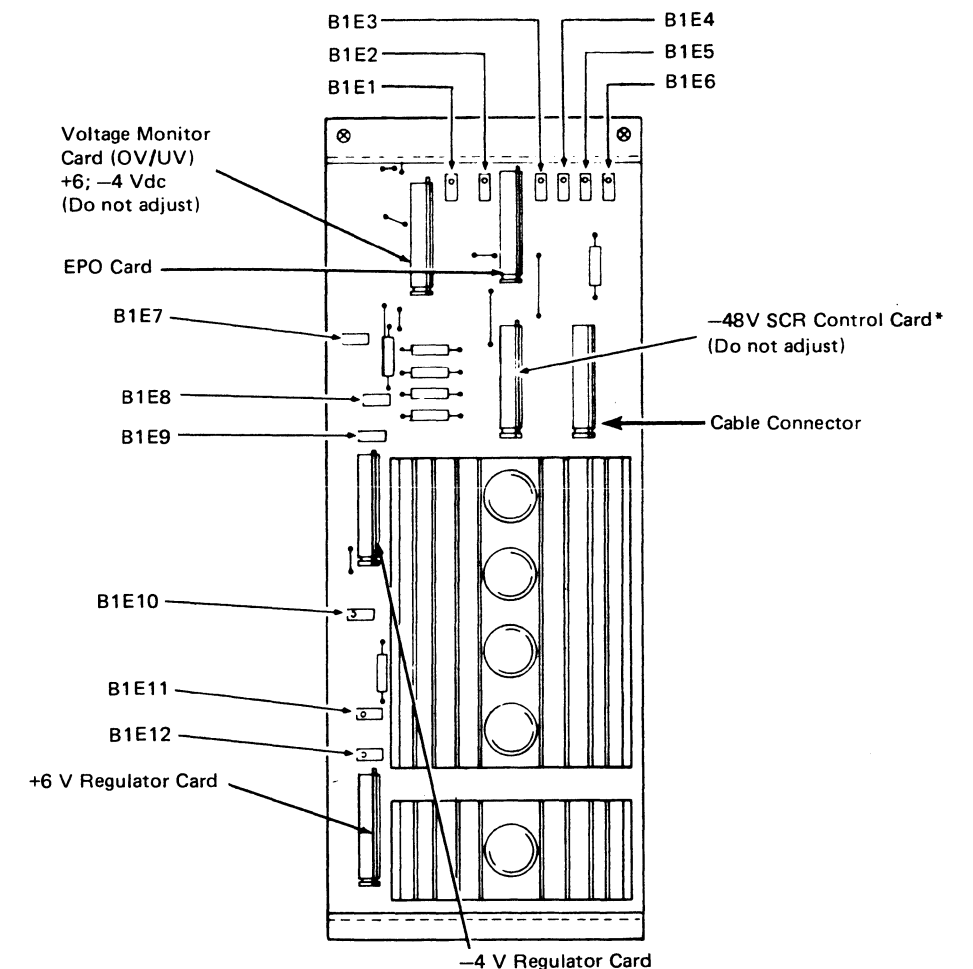

\*Not included in power supply  
Part Numbers 1767917, 1767918

<b>3803-2/3420</b>	<b>XC0100</b> Seq 2 of 2	<b>2735778</b> Part Number	<b>See EC History</b>	<b>845958</b> 1 Sep 79	<b>846927</b> 20 Jun 80	<b>847298</b> 15 Aug 83		
--------------------	-----------------------------	-------------------------------	-----------------------	---------------------------	----------------------------	----------------------------	--	--

**1B-001**

**FILE PROTECT INDICATOR OFF OR POWER CHECK INDICATOR ON (Cont'd)**

1B-002

Seq	Condition/Instruction	Action
41	If not:	Most Probable Causes: 1. Defective File Protect lamp. 2. Defective File Protect switch. 3. Binding File Protect plunger. 4. Defective Write Enable relay card. (Located below right reel motor) 5. Defective card T-A1M2. Go to ALD ZT071 for further analysis.
42	Is The cooling blower operating?	Go to Seq 44.
43	If not:	Refer to ALD YF030/5. Repair or replace as required.
44	Is there sufficient airflow at the logic gate? Compare with another drive, if necessary.	Go to Seq 46.
45	If not:	Check the air filter, hoses, ducts, blower motor, fan blades, and motor direction.
46	Are the voltages out of specification? Ripple specification for -4 Vdc and +6 Vdc is 24 mv dc peak-to-peak. Measure at power supply.	Adjust, replace or repair the regulator cards and/or interface board as necessary.  See ALD YF020/5 or ALD YF040/5 to help locate these cards. <b>A</b>
	<b>Value</b>	<b>Test Point</b>
	+6V; ±0.1V	T-A1G2B11 T-A1G2D08
	+11V; +1.7-1.1V	TB2-1 TB2-4
	-4.05V; ±0.05V	T-A1H1C09 T-A1G2D08
	-48V;	TB1-9 TB1-8
+12V; +1.4, -0.9V	TB3-1 TB3-4	
-12V; ±1.1V	TB3-5 TB3-7	
47	Is the POWER CHECK indicator On?	Turn power off. Change the voltage monitor card. Restore power. See ALD YF020/5, YF040/5, YF050/5 and YF060 to help locate these cards. Go to Seq 49.
48	If not:	Go to 00-030.
49	Is the POWER CHECK indicator still On?	Connect a jumper to terminal board connectors TB3-3 to TB3-8. Go to Seq 51.
50	If not:	Go to 00-030.
51	Does the POWER CHECK indicator now go off?	Most Probable Causes: 1. Defective mercury switch on the movable air vane. 2. Insufficient air flow.
52	If not:	Remove the jumper and recheck the symptoms.

Seq	Condition/Instruction	Action
53	Turn power off. Replace the blown fuse or reset CP6 (-4 Vdc).  F1 6A fast 4.5 Vac F3 6A fast +6 Vdc F5 8A medium +12 Vdc <b>B</b> F6 15A medium -12 Vdc F7 2A inst +12 Vdc Reg*  *No external load—used only to provide +12 V reference to voltage monitor (VM). P/N 375470. See ALD YF040/5 for F1, CP6, and F3 and ALD YF020/5 for F5, F6, and F7. Restore power.	
54	Does the fuse blow or CP trip again?	Turn power off. Disconnect load to blown fuse at terminal board. Replace the blown fuse or reset CP.  F1 B1E3 See Modified 3420 CP6 B1E8 Power Interface F3 B1E10 Board on 1B-001 F5 TB3-1; TB3-2 (gray wires) F6 TB3-5; TB3-6 (purple wires) (dc ground is TB1-8) Restore power. Go to Seq 56.
55	If not:	Go to Seq 42.
56	Does the fuse blow again?	Go to Seq 59.
57	Turn power off.  Measure from the removed wire to ground and to other voltages for shorts. Repair as required. See ALD ZT031 for 4.5 Vac and ALD ZT051 for dc voltages.	

**Terminal Boards 1, 2, and 3**

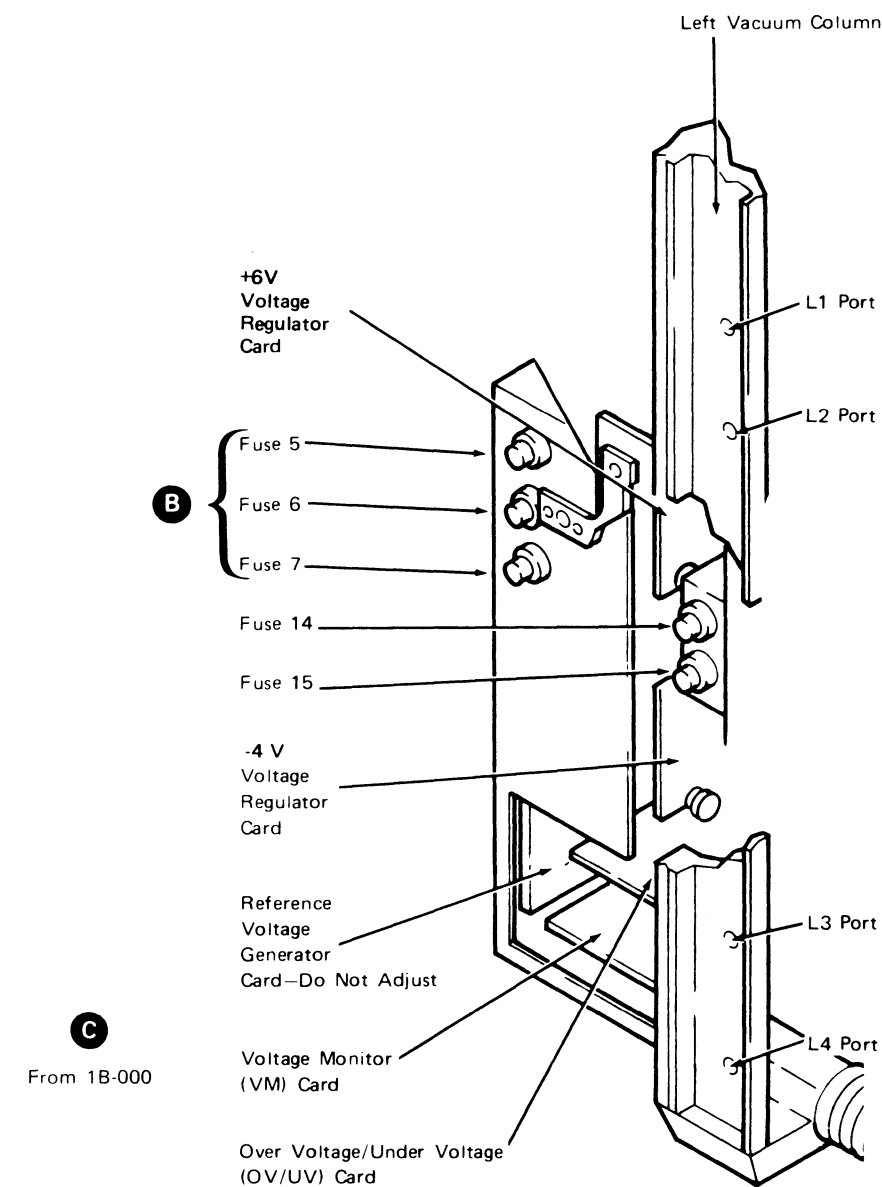
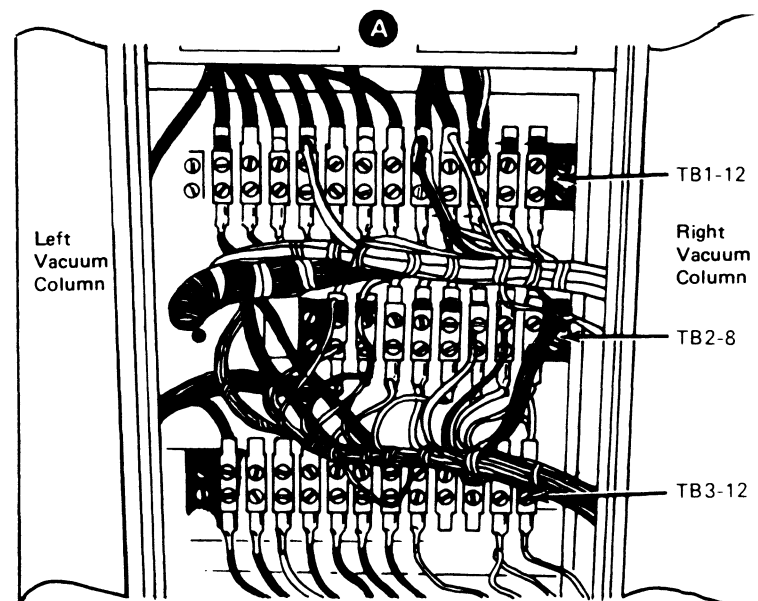

3803-2/3420

XC0200	2735779	See EC History	845958	846927	847298
Seq 1 of 2	Part Number		1 Sep 79	20 Jun 80	15 Aug 83

© Copyright International Business Machines Corporation 1976, 1979, 1980, 1983

1B-002

**FILE PROTECT INDICATOR OFF OR POWER CHECK  
INDICATOR ON (Cont'd)**

**1B-003**

Seq	Condition/Instruction	Action
58	Reconnect leads previously removed from the terminal board. Restore power and operate tape unit.	Go to 00-030.
59	Does F1, F5, or F6 blow?	There is a wiring problem in the power supply—see ALD YF020/5 (F5 and F6) or ALD YF040/5 (F1). Repair as required. Restore power. Go to 00-030.
60	Is CP6 tripped or did F3 or F7 blow?	Turn power off. Remove regulator card associated with fuse that has blown. See fuse specification in Seq 53 and ALD YF040/5 (CP6 and F3) or ALD YF020/5 (F6). Replace fuse. Restore power.
61	Does a fuse blow again?	Turn power off. Check wiring from fuse to regulator card. Correct wiring problem and reinstall regulator cards previously removed. See ALD YF020/5 and ALD YF040/5. Restore power. If fixed, go to 00-030.
62	Install new regulator card and adjust the voltage.	
63	Does the fuse blow again?	Turn power off. Replace the associated capacitor and fuse. Restore power. Go to 00-030.
64	If not:	Go to 00-030.

3803-2/3420

XC0200	2735779	See Ec	845958	846927	847298			
Seq 2 of 2	Part Number	History	1 Sep 79	20 Jun 80	15 Aug 15			

© Copyright International Business Machines Corporation 1976, 1979, 1980, 1983

**1B-003**



# DROPPING READY AND THREAD AND LOAD FAILURE SYMPTOMS

2B-000

From 00-040, Start 2		
<b>Most Probable Causes:</b>		
<ol style="list-style-type: none"> <li>Cards at T-A1C2, T-A1D4, T-A1B2</li> <li>Optic Lamp</li> <li>Capstan Tach Adjustment</li> <li>Vacuum switches L4 and R4</li> </ol>		
<b>Notes:</b>		
<ol style="list-style-type: none"> <li>The vacuum column vents (P/N 1846701) require special adjustments if both standard and minireels are used interchangeably on the drive. See 08-800 for vacuum adjustment procedures.</li> <li>Intermittent Dropping Ready and thread and load problems can be caused by:             <ol style="list-style-type: none"> <li>BOT/EOT out of adjustment.</li> <li>A loose pressure manifold on the 3-way valve (transfer valve assembly). The manifold is attached to the 3-way valve with four screws. Overtightening these screws can fracture or break off the mounting studs causing an air leak.</li> <li>A dirty pressure pump input filter element.</li> <li>A leaking transfer valve. See 08-400 for leakage test.</li> <li>Vacuum column door leaking or out of adjustment.</li> <li>A dirty pressure pump output filter element.</li> <li>Damaged or aged vacuum column door foam. (See 08-690).</li> </ol> </li> </ol>		
<b>Always start with Seq 1 and follow the procedure in sequence unless directed otherwise. Remember to END all problems or maintenance calls by going to MAP 00-030.</b>		
Seq	Condition/Instruction	Action
1	Does problem exist only when using minireels?	Go to 08-800.
2	With the tape unit unloaded, and before depression of the load button, is the pneumatic motor running?	Go to 4B-160.
3	Is the tape unit dropping READY?	Go to Seq 32.
4	With the tape unit unloaded is the capstan turning continuously?	Go to 6B-000.
5	Mount a reel of tape with a properly crimped and positioned end (see 2B-006) and a properly placed BOT reflective marker. The field tester should not be plugged into the tape unit. Press the LOAD REWIND pushbutton, then the START pushbutton. Approach any unusual symptoms not specifically asked (that is, reels turning with no buttons pressed, etc.) as a load failure.	
6	Is a cartridge being used?	If the cartridge doesn't open fully, go to 2B-100. Otherwise, proceed to Seq 7.
7	Does the left reel turn clockwise at threading speed? Compare with another drive.	Go to Seq 9.
8	If not:	Go to 2B-110.
9	Does the right reel turn clockwise at threading speed? Compare with another drive.	Go to Seq 11.

Seq	Condition/Instruction	Action
10	If not:	Go to 2B-120.
11	Does the tape thread past the read/write head?	Go to Seq 14.
12	Does the tape thread directly into the right vacuum column?	Go to 2B-130.
13	If not:	Go to 2B-140.
14	Does the tape thread onto the left reel?	Go to Seq 16.
15	If not:	There may be no vacuum at the left reel hub. Check the vacuum and pneumatic belts. Check transfer valve for proper operation during thread status. If pneumatics appear OK, change T-A1F2. See Pneumatic Pressure, Vacuum Checks on 08-400.
16	Does a Load Check occur before the BOT marker has passed the BOT/EOT block?	Go to 2B-150.
18	Does tape load into the columns. As long as tape enters into both columns properly, the answer to this is yes, even if tape bottoms in one or both columns.	Go to Seq 20. See Note 1
19	If not:	Go to Seq 26. See Note 1
20	Does the tape move backwards properly until it stops at the BOT marker?	Go to Seq 28.
21	Does the tape bottom, bobble, or pull out of either vacuum column?	Go to 2B-170.
22	Does the tape rewind off the left reel or does the tape unit perform a normal unload/rewind?	Go to 2B-190.
23	Does the tape go forward at normal speed after loading into vacuum column?	Go to 2B-200.
24	Does the capstan move tape at all?	Go to 2B-170.
25	If not:	Go to 2B-175.
26	Does tape load into one column, but not the other?	See Note 2.e, then go to 2B-180.
27	If not:	Go to 2B-160.
28	Is the window up and the READY indicator On?	Go to Seq 31.
29	Does the Ready indicator fail to turn on and stay on?	Go to 2B-210.
30	Is the window down and the READY indicator On?	Check the Window-up switch <b>A</b> on the window printed circuit board for a shorted condition.

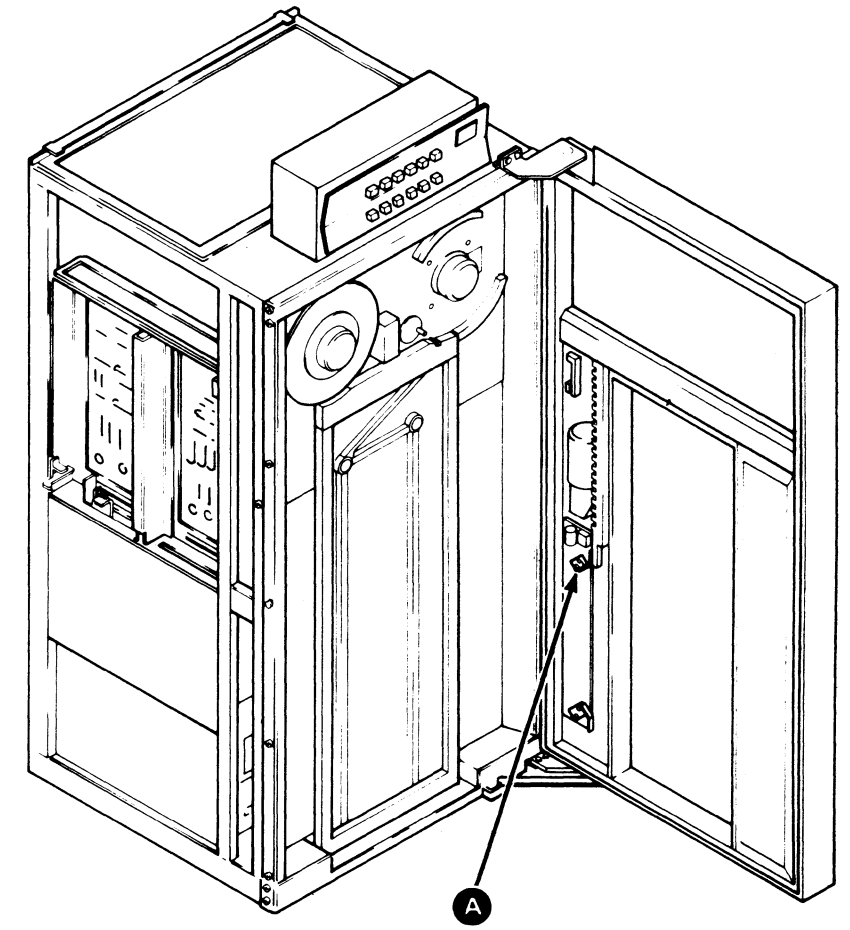

3803-2/3420

XC0300	2735780	See EC History	845958	846927	847298			
Seq 1 of 2	Part Number		1 Sep 79	20 Jun 80	15 Aug 83			

© Copyright International Business Machines Corporation 1976, 1979, 1980, 1983

2B-000

**DROPPING READY AND THREAD AND LOAD FAILURE SYMPTOMS  
(Cont'd)**

2B-001

Seq	Condition/Instruction	Action
31	If not:	Go to 3B-000.
32	Is Drop Ready failure intermittent?	See Note 2, then go to Seq 38.
33	If not:	Approach as a load failure. Go to Seq 5.
34	Is tape bobbling in either column?	Go to Seq 36.
35	If not:	Go to 3B-000.
36	Is tape bobbling in one column only?	Interchange reel motor boards. Part numbers must be the same. If trouble follows, replace the bad board. If not, go to Seq 37.
37	If not:	Check for -12 Vdc at J2-2 (ALD RM001) of each reel board. If defective, check relay points K2-3 on MSC card (ALD YC021). If tape unit still fails, change:  1. T-A1G6 2. T-A1B2 3. MSC Card
38	Is sense byte 7 available?	Go to 2B-005, Chart A, column 3.
39	Is a visual symptom or customer description available?	Go to 2B-005, Chart A, column 1.
40	Does the failure still exist?	Scope tape logic pins in Chart A, column 2, on 2B-005. If problem still exists, refer to intermittent Drop Ready Problems on 2B-005.
41	If not:	Go to 00-030.

3803-2/3420

XC0300	2735780	See EC	845958	846927	847298			
Seq 2 of 2	Part Number	History	1 Sep 79	20 Jun 80	15 Aug 83			

© Copyright International Business Machines Corporation 1976, 1979, 1980, 1983

2B-001



# INTERMITTENT DROP READY PROBLEMS

2B-005

Listed below are several causes of dropping Ready. Most probable cause is listed first. Examine the list and do any indicated action. Using Chart A.

- Vacuum Switches:** Defective vacuum switches cause dropping Ready problems. If sense byte 7 is available, it can be helpful in determining which vacuum column is failing. Go to 08-450 to check vacuum switches.
- Fiber Optics:** Faulty or marginal fiber optics can cause tape loading problems, tape motion problems, and dropping Ready. Check seating and clean the fiber optic bundles at the light source. Assure that the lamp is clear and replace it if questionable. (See 08-620.)
- Capstan Squaring:** If capstan squaring is out of adjustment it will usually show up first by dropping Ready (pulls out of left column, or bottoms in right column) when going into or coming out of a high speed rewind, or dropping out of high speed rewind early on machines with EC 847234. See 08-120 for Model 4, 6, or 8 adjustment procedure. See 08-140 for cleaning procedure on Models 4 and 6.
- Right Reel Slipping on Hub:**  
**Caution: Circuit damage or a blown fuse (F12) may result if the reel is held for more than five or six seconds.**  
 Slippage can be determined by loading a tape and turning the right reel until tape in the column is above, then below the ports causing the right reel to drive. Hold the reel to keep the tape and hub from turning and observe the amount of slippage. Compare with a known good tape unit. If excessive slipping is observed, go to 08-470 through 08-520 for checks and adjustments.
- Reel Tachs:** Defective reel tachs cause a tape unit to fail to enter high speed rewind and also cause dropping Ready while in high speed rewind. Check tachs for polished surfaces causing them to slip on the tape. If this condition is found, replace the reel tach assembly (08-550). Also check for binds in the bearings and tach wobble indicating worn bearings. Scope tach outputs (ALD FT231) for pulses of similar frequency, duration, and amplitude.

- Reel Motor Boards:** Either board causes intermittent problems. Check for cold flow solder joints, cracked land patterns, and loose or pushed in pins in the connectors. If boards are suspect, interchange them with another tape unit to isolate the failure. (ALD RM001).
- Door Interlock:** Machine vibration can cause a badly adjusted Door Interlock switch to open intermittently. Also check main machine door latch alignment.
- Damaged Tape:** Stretched or spliced tape causes dropping Ready. If the failing tape has been retained make one complete pass, using the field tester.
- Power Supply:** Check for loose terminal connections and cold flow solder joints. Ask operator if power check light has been flashing. (Power check circuit is not latched.)  
**Note:** If tape bottoms intermittently in either column, the capstan armature could be open. Unplug the capstan motor plug from the capstan board and measure across the two wires going to the motor with an ohm meter. Watch for a deflection on the meter while rotating the capstan very slowly by hand.

Chart A

1	2	3			
Error Description	Drive Error Condition	Error Sense	Probable Drive FRUs	Further Analysis	Notes
Fiber optic lamp failure not latched	+ at T-A1M2S07	Byte 7 Bit 0	Fiber optic lamp, T-A1D2	See ALD FT114	
Tape Bottoms (See Note) or pulls out of left column	+ at T-A1M2U02	Byte 7 Bit 1	T-A1C2, T-A1M2 L-4 vacuum switch, left reel board. (Check reel board EPO relay for shorted points.) Capstan Tach.	Go to 3B-110	Could be caused by OV/UV detection or capstan board cooling sensor. See Byte 18, Bit 0. Model wiring ALD 6106 (4 & 6).
Tape bottoms (see Note) or pulls out of right column	+ at T-A1M2U05	Byte 7 Bit 2	R4 vacuum switch, right reel board. (Check reel board EPO relay for shorted points.) Capstan Tach.	Go to 3B-110	Could be caused by OV/UV detection or capstan board cooling sensor. See Byte 18, Bit 0. Model wiring ALD 6106 (4 & 6).
Reset key or door interlock	- at T-A1M2S08	Byte 7 Bit 3	Reset key, door interlock switch, T-A1C2, A-B3F2, A-A2D2	See ALD FT114	Could be operator caused.
Air bearing pressure or right reel hub air failure	+ at T-A1M2S04	Byte 7 Bit 6	Leaking file hub. Air bearing or hub switch. Loose/worn belt. Air system leak.	See ALD FT114	If a solid failure, tape will not dump into columns during a load operation.
OV/UV (power check) or no cooling air to capstan board	- at T-A1M2S02	Byte 18 Bit 0	Check voltages. Dirty filter, defective cooling fan. Check mercury switch below capstan board.	Go to 1B-000	These errors cause reel board EPO relays to drop resulting in loss of motor control. Tape bottoming will then drop ready.
Power On Reset not latched	+ at T-A1M2M05		T-A1C2, T-A1D4 Fuse Detect Card	See ALD FT112	This is not a normal drop Ready condition. However, intermittent failure may appear as a drop Ready.
Safety Bail reset not latched	+ at T-A1D4B09		T-A1C2, T-A1D4 T-A1K2	See ALD FT283	This is not a normal drop Ready condition. However, intermittent failure may appear as a drop Ready.
Erase Unit Check	+ at T-A1M2S05	Byte 7 Bit 5	Erase head, Write card T-A1M2	See ALD FT111	Check for loose write cable at board and card
Write Current Unit Check	+ at T-A1M2P10	Byte 6 Bit 1	R/W head, Write card at T-A1M2	See ALD FT111	Check for loose write cable at board and card

3803-2/3420

XC0310 Seq 1 of 2	8492595 Part Number	See EC History	845958 1 Sep 79	846927 20 Jun 80	847298 15 Aug 83			
----------------------	------------------------	-------------------	--------------------	---------------------	---------------------	--	--	--

© Copyright International Business Machines Corporation 1976, 1979, 1980, 1983

2B-005

# TAPE CRIMPER PROCEDURE

2B-006

Insert the tape with the oxide side towards the plunger and in a direction that will produce a rounded end when cut. See figure below. Cutting tape with the oxide side away from the plunger can cause intermittent thread problems because the tape will have a tendency to curl the wrong direction.

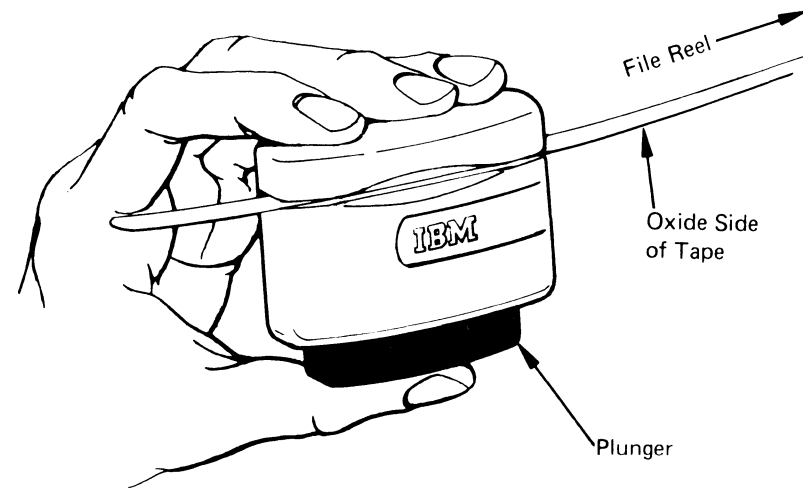

3803-2/3420

XC0310	8492595	See EC	845958	846927	847298			
Seq 2 of 2	Part Number	History	1 Sep 79	20 Jun 80	15 Aug 83			

© Copyright International Business Machines Corporation 1976, 1979, 1980, 1983

2B-006

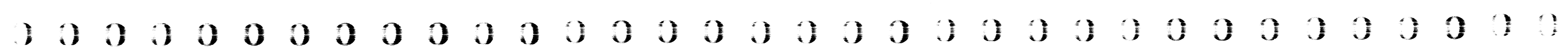



# THREAD AND LOAD OPERATIONS

2B-020

The 3420 threads, loads, and unloads tape automatically with or without a tape cartridge. Air pressure automatically secures the reel of tape to the right reel hub. Any size reel of half-inch (1.27 mm) magnetic tape can be automatically loaded, but only full 10 1/2-inch (26.67 mm) reels can be loaded with a cartridge.

## THREAD AND LOAD WITH CARTRIDGE—TIMING CHART

A plunger on the tape unit senses that a cartridge is mounted on the right reel hub. Pressing LOAD REWIND (timing chart line 2) activates the Load Op latch. The Load Op latch:

- Activates Power Window Motor, which closes the window.
- Activates Thread Status, which energizes the transfer valve solenoid to switch vacuum and air pressure to threading positions.
- Conditions the reel motors to turn in a clockwise (forward) direction (Section 3B-020).
- Activates Drive Cartridge Motor, which energizes the cartridge motor and causes the cartridge opener to rotate 200 degrees to a fully open position. When the cartridge is fully open, the Cartridge Open switch removes power from the cartridge motor.

With the cartridge open, the right reel starts feeding tape out the cartridge tape port and into the right threading channel, while the left reel is already moving. The radius sense photocell drives the interblock gap (IBG) counter, which clocks the threading and loading sequences. (See Section 6B-210.) The IBG counter receives a pulse for each half turn of the left reel.

Tape moves through the threading channels and the head area guided by air pressure and vacuum ports. As tape leaves the left threading channel, vacuum at the left reel hub draws the tape to the reel.

As tape is wrapped on the left reel, a slight tension forces the tape against the reels loaded sensing port. Sealing this port causes a pressure change, which signals the reel loaded condition.

The reels continue turning forward until the beginning-of-tape (BOT) marker or Load Point marker is sensed at the BOT photocell. The BOT phototransistor activates the BOT singleshot which:

- Resets the IBG counter to zero.
- Activates the Load Rewind. line.
- Activates the Rewind Operation lines.
- Activates the Backward Status line.

The IBG counter resumes counting from zero. At a count of 4, Thread Status is deactivated and the transfer valve solenoid is de-energized. Air pressure is now directed to the air bearings, and vacuum is switched to the vacuum columns, the capstan motor, and the tape cleaner blade.

Air Bearing Pressure and Not Thread Status reverse the direction of the left reel motor.

As the left reel turns counterclockwise, the right reel continues to turn clockwise. The tape lowers into the vacuum columns until it is below port L2 in the left column and port R1 in the right column. With the tape in this position:

- Halt Right Reel Load is activated.
- Halt Left Reel Load is activated.
- Columns Loaded is activated which activates Load Complete and deactivates Manual Status.

With Manual Status deactivated, normal column control becomes active. The capstan motor moves tape backward to the BOT marker. (See "Capstan System" on 6B-200 for explanation of capstan circuits).

Pressing START activates Ready Status in the tape unit.

## Thread and Load Timing Chart

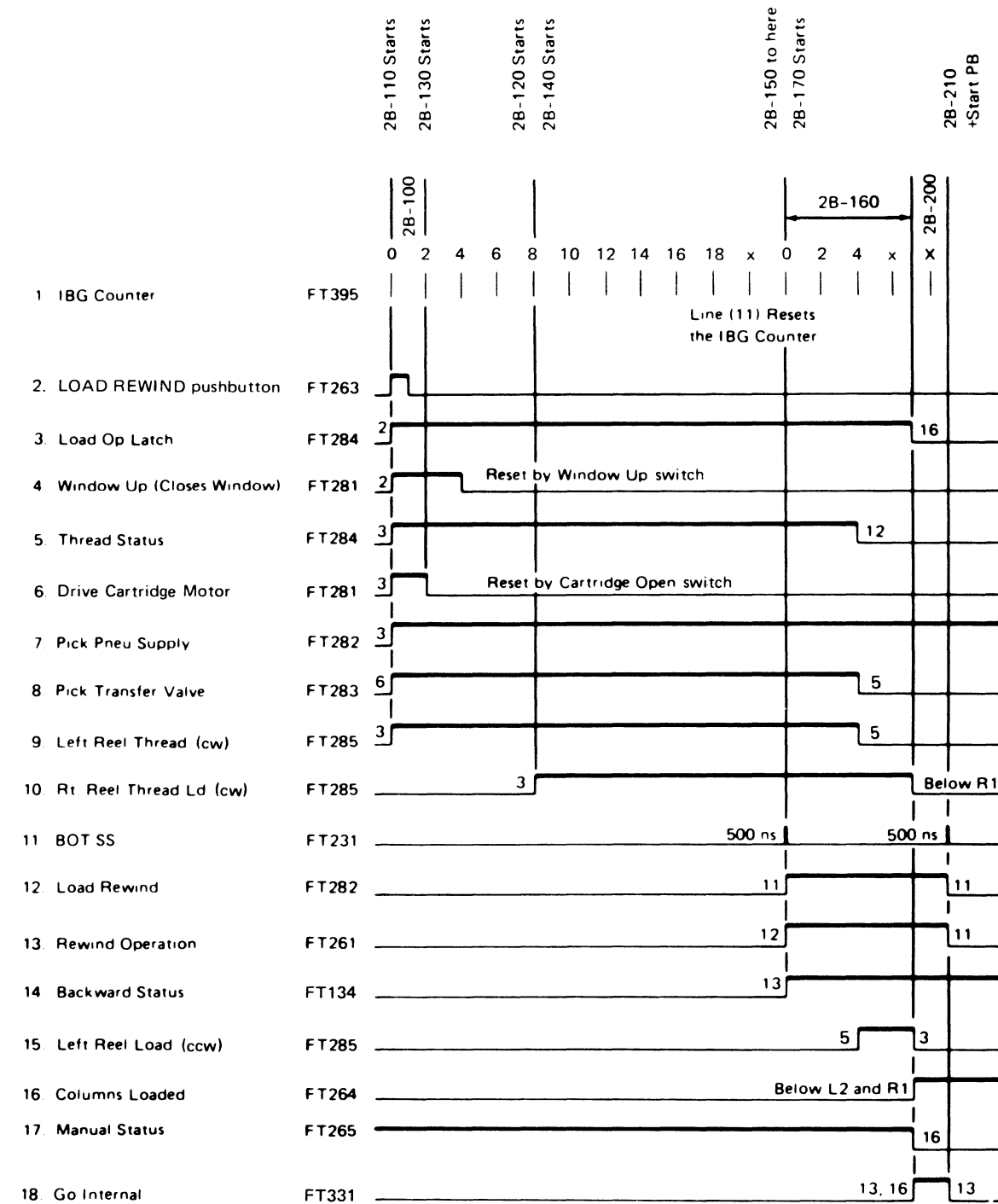

**Note:**

X = Number of IBG Counts needed to reach the BOT marker.

3803-2/3420

XCO320	4169690	See EC	845958	847298				
Seq 1 of 2	Part Number	History	1 Sep 79	15 Aug 83				

© Copyright International Business Machines Corporation 1976, 1979, 1983

2B-020

NOTES:

2B-021

3803-2/3420

XC0320 Seq 2 of 2	4169690 Part Number	See EC History	845958 1 Sep 79	847298 15 Aug 83				
----------------------	------------------------	-------------------	--------------------	---------------------	--	--	--	--

© Copyright International Business Machines Corporation 1976, 1979, 1983

2B-021

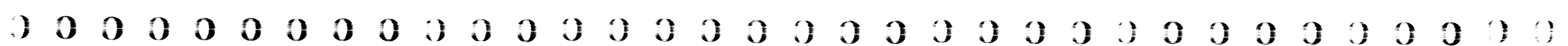

**THREAD AND LOAD CHECKING WITH CARTRIDGE—TIMING CHART**

The thread and load operations are checked at several points in the cycle. If the first attempt to thread and load fails, a second attempt is made. If the second attempt fails, a permanent Load Check error is set.

On the first attempt, tape must be sensed at BOT/EOT phototransistors before interblock gap (IBG) count 14. Failure to meet this condition usually results from the end of tape being in the wrong place in the cartridge or a damaged leader on the tape.

A second check is made at IBG count 24. At this point, the Reels Loaded switch must be transferred. If the tape does not wrap around the left hub, the switch cannot be transferred.

A failure at either IBG count 14 or 24 causes the tape to be rewound on the file reel. The IBG counter continues to count as the left reel turns counterclockwise. At IBG count 40, the second attempt begins, and, the Reels Loaded switch must be transferred before IBG count 56. If a failure occurs at IBG count 56, the tape rewinds on the file reel, and the thread and load operation ends. The Load Check light remains on.

After a successful reels loaded sequence, the BOT marker must be detected before IBG count 80 (72 without EC 846437). If it isn't detected before IBG count 80 (72 without EC 846437), the operation stops, and the operator determines if the BOT marker is in the correct place on the tape.

A final check is made eight IBG counts after the BOT marker is detected. By this time, the Vacuum Present switch L4 must be transferred, or the operation stops and operator intervention is required.

No additional attempts are made to load the tape unit if the BOT marker is not detected before IBG 80 (72 without EC 846437), or if the Vacuum Column switch L4 is not transferred.

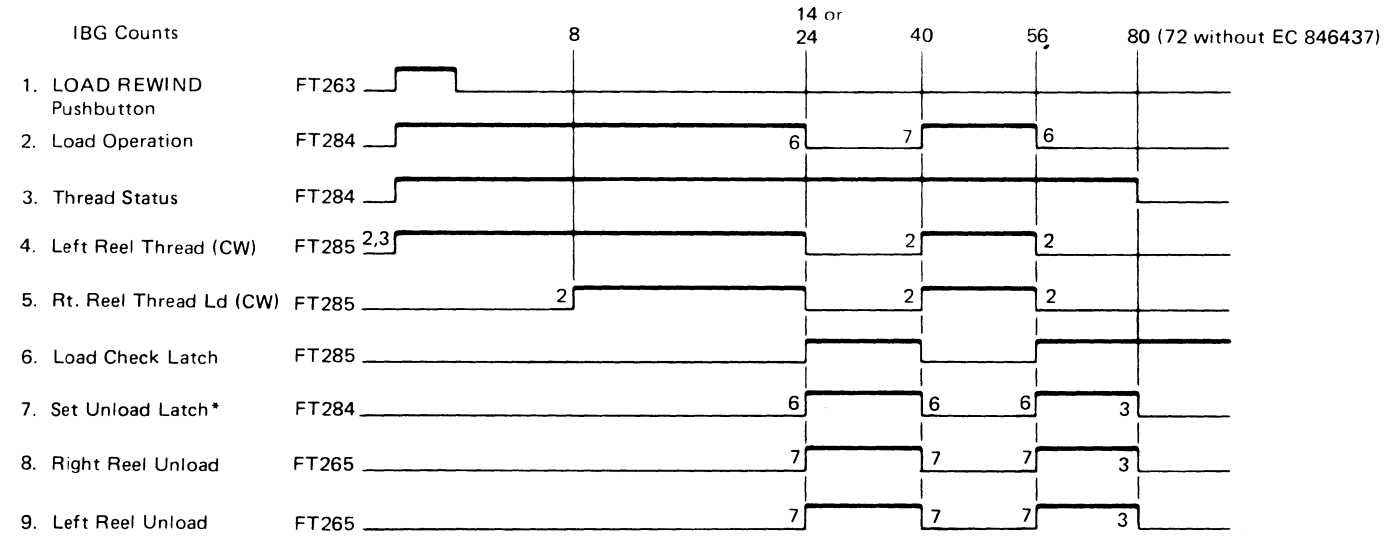

\* Unload Op (ALD FT265) is not set.

**THREAD/LOAD WITHOUT CARTRIDGE (DIFFERENCES)**

The cartridge opening motor is de-energized to prevent unnecessary motor travel during thread and load without a cartridge.

**THREAD/LOAD CHECKING WITHOUT CARTRIDGE (DIFFERENCES)**

Without a cartridge, the first check is made at IBG 24 (18 without EC 846437). At this point, the Reels Loaded switch must be transferred, or the tape operation stops and there is no other attempt.

If the thread and load sequence is successful, the remaining checks are the same as with a cartridge.

3803-2/3420

XC0400	2735781	See EC	845958	846927	847298			
Seq 1 of 2	Part Number	History	1 Sep 79	20 Jun 80	15 Aug 83			

© Copyright International Business Machines Corporation 1976, 1979, 1980, 1983

# CARTRIDGE DOES NOT OPEN

The LOAD REWIND pushbutton sets Load Op (ALD FT284) and causes the cartridge motor to open the cartridge. The cartridge opener is rotated 200 degrees to a fully open position. The Cartridge Open switch then transfers and removes power from the cartridge motor. The Cartridge Open and Cartridge Closed switches are inside the cartridge opening mechanism.

Conditions that prevent setting Load Op, and keep the cartridge motor from operating are:

1. The Door Interlock switch is open.
2. L4 and/or R4 Vacuum switch is indicating a tape bottomed condition.
3. The RESET pushbutton was pressed.
4. Safety Bail switch is tripped.
5. Any condition present that deactivates Mechanical Ready. Mechanical Ready is deactivated by Lamp Off, Tape Bottomed, or Air Pressure Failure.

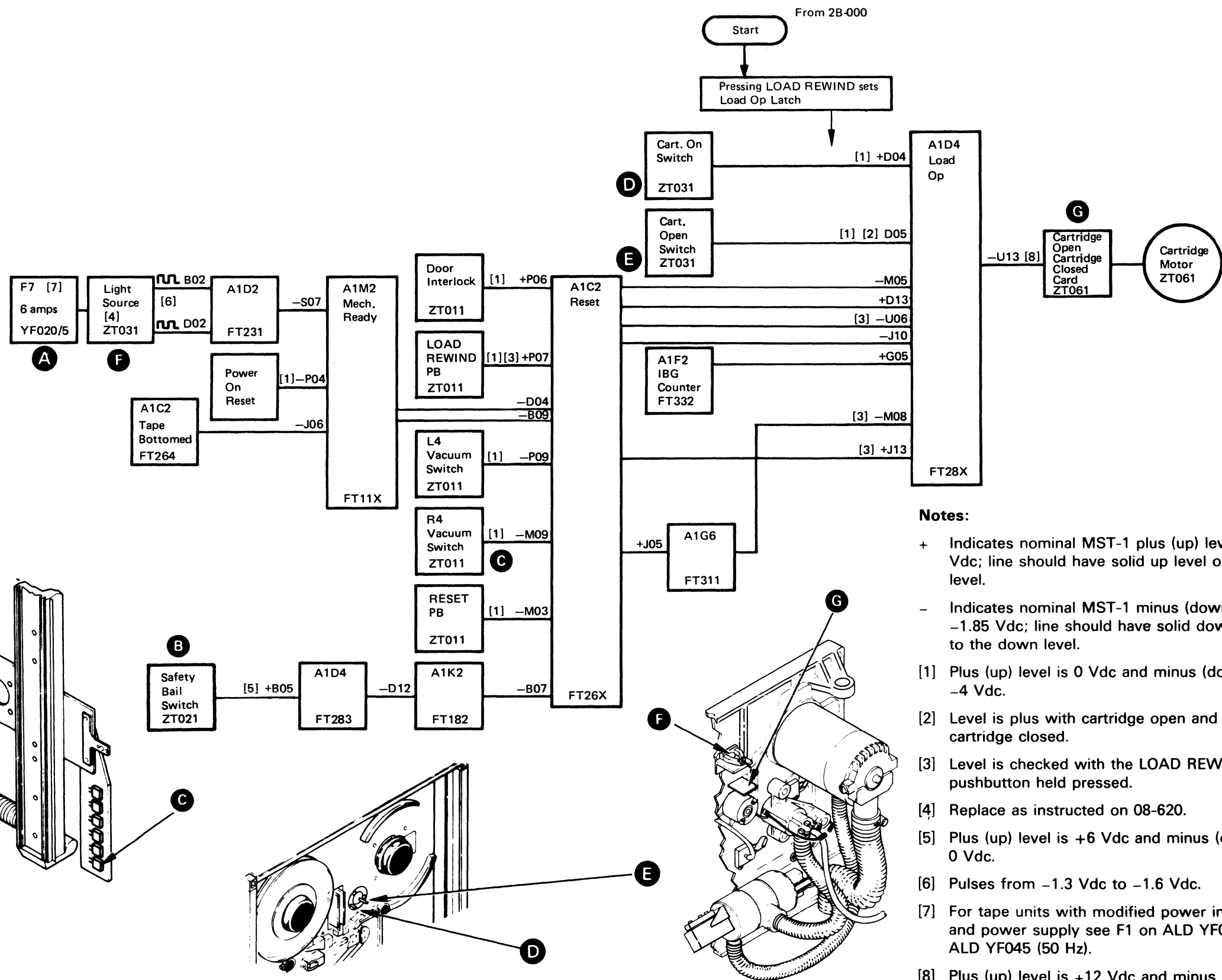

- Notes:**
- + Indicates nominal MST-1 plus (up) level of -0.85 Vdc; line should have solid up level or go to the up level.
  - Indicates nominal MST-1 minus (down) level of -1.85 Vdc; line should have solid down level or go to the down level.
  - [1] Plus (up) level is 0 Vdc and minus (down) level is -4 Vdc.
  - [2] Level is plus with cartridge open and minus with cartridge closed.
  - [3] Level is checked with the LOAD REWIND pushbutton held pressed.
  - [4] Replace as instructed on 08-620.
  - [5] Plus (up) level is +6 Vdc and minus (down) level is 0 Vdc.
  - [6] Pulses from -1.3 Vdc to -1.6 Vdc.
  - [7] For tape units with modified power interface board and power supply see F1 on ALD YF040 (60 Hz) or ALD YF045 (50 Hz).
  - [8] Plus (up) level is +12 Vdc and minus (down) level is 0 Vdc.

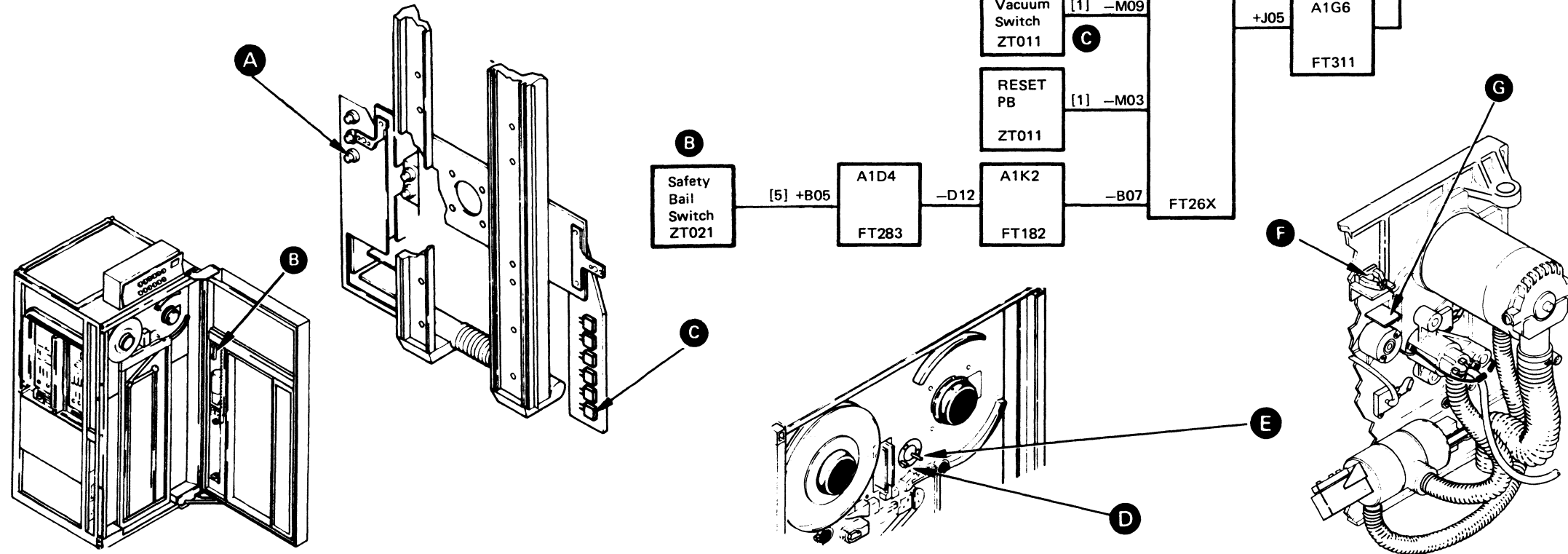

3803-2/3420	XC0400	2735781	See EC History	845958	846927	847298			
Seq 2 of 2	Part Number			1 Sep 79	20 Jun 80	15 Aug 83			

NOTES:

2B-105

3803-2/3420

XC0450 Seq 1 of 2	4169689 Part Number	See EC History	845958 1 Sep 79	846927 20 Jun 80	847298 15 Aug 83			
----------------------	------------------------	-------------------	--------------------	---------------------	---------------------	--	--	--

© Copyright International Business Machines Corporation 1976, 1979, 1980, 1983

2B-105

# LEFT REEL DOES NOT TURN CLOCKWISE AT THREADING SPEED

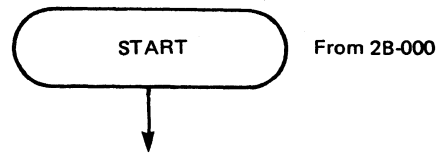

Pressing the LOAD REWIND pushbutton sets the Load Op latch (ALD FT284). If tape is not present, Thread Status is activated causing the left reel to rotate clockwise at threading speed.

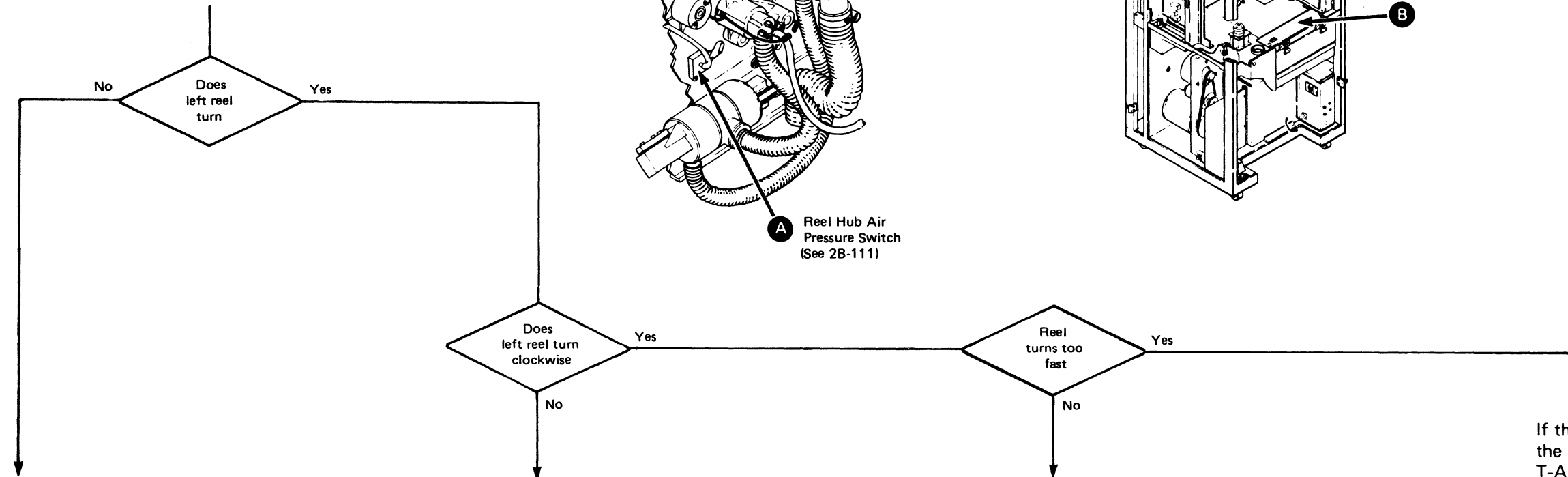
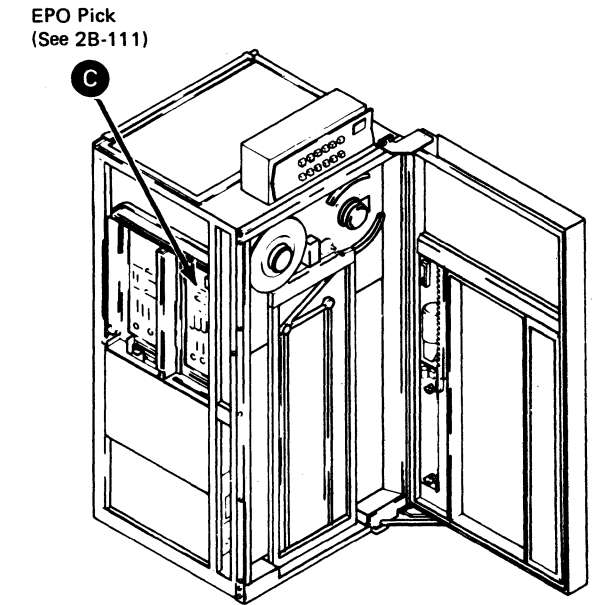
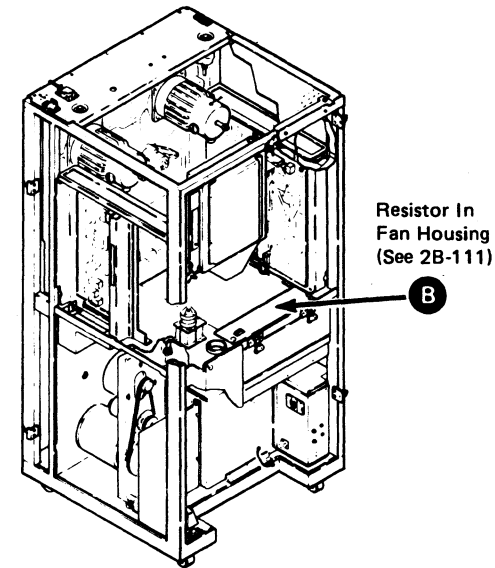
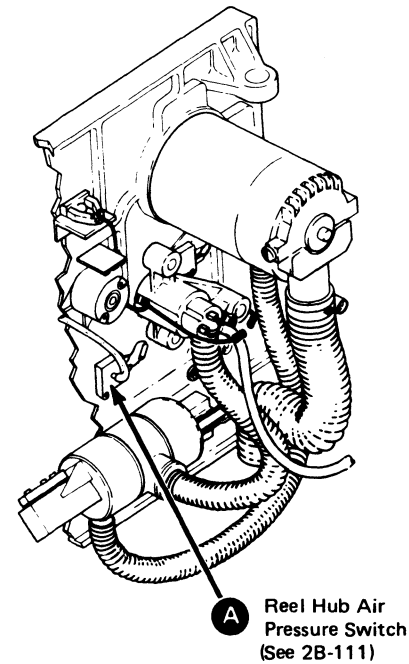

Conditions which prevent the left reel from turning after LOAD REWIND is pressed are:

1. Door interlock open.
2. RESET pushbutton activated.
3. Air pressure failure.
4. RESET is active.
5. Tape bottomed.
6. R4 Vacuum Switch fails.
7. L4 Vacuum switch fails.
8. Unload Op active.
9. Left reel binding against frame.

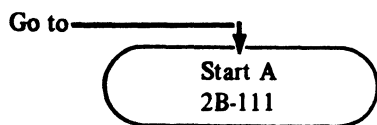

If Tape Present (ALD FT231) is active when LOAD REWIND is pressed, the tape unit attempts a mid-tape load. The left reel turns counterclockwise and the right reel turns clockwise to load tape into the columns.

Probable FRUs:

1. Clean and adjust or change EOT/BOT.
2. Safety bail operated.

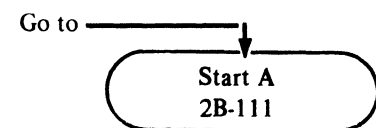

Reel turns too slow. Left reel pulses are measured at T-A1D2G10 and should be 180 milliseconds apart.

Probable FRUs:

1. Open resistor in fan housing.
2. Resistors in fan housing are unplugged.

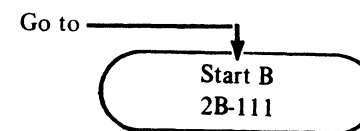

If the left reel turns too fast, the tape will not wrap on the left reel. Left reel pulses are measured at T-A1D2G10 and should be approximately 180 milliseconds apart.

Probable causes:

1. -45 volts was applied to the reel motors during threading and loading.
2. The MSC card and the power supply are not supplying the correct armature voltage.

During thread and load operations, the armature has 8-12 volts dc applied (depending on the circuit load) and the field has 45 volts applied.

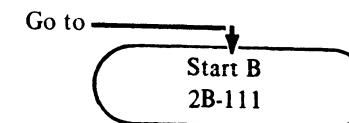

3803-2/3420

XC0450	4169689	See EC History	845958	846927	847298		
Seq 2 of 2	Part Number		1 Sep 79	20 Jun 80	15 Aug 83		

© Copyright International Business Machines Corporation 1976, 1979, 1980, 1983

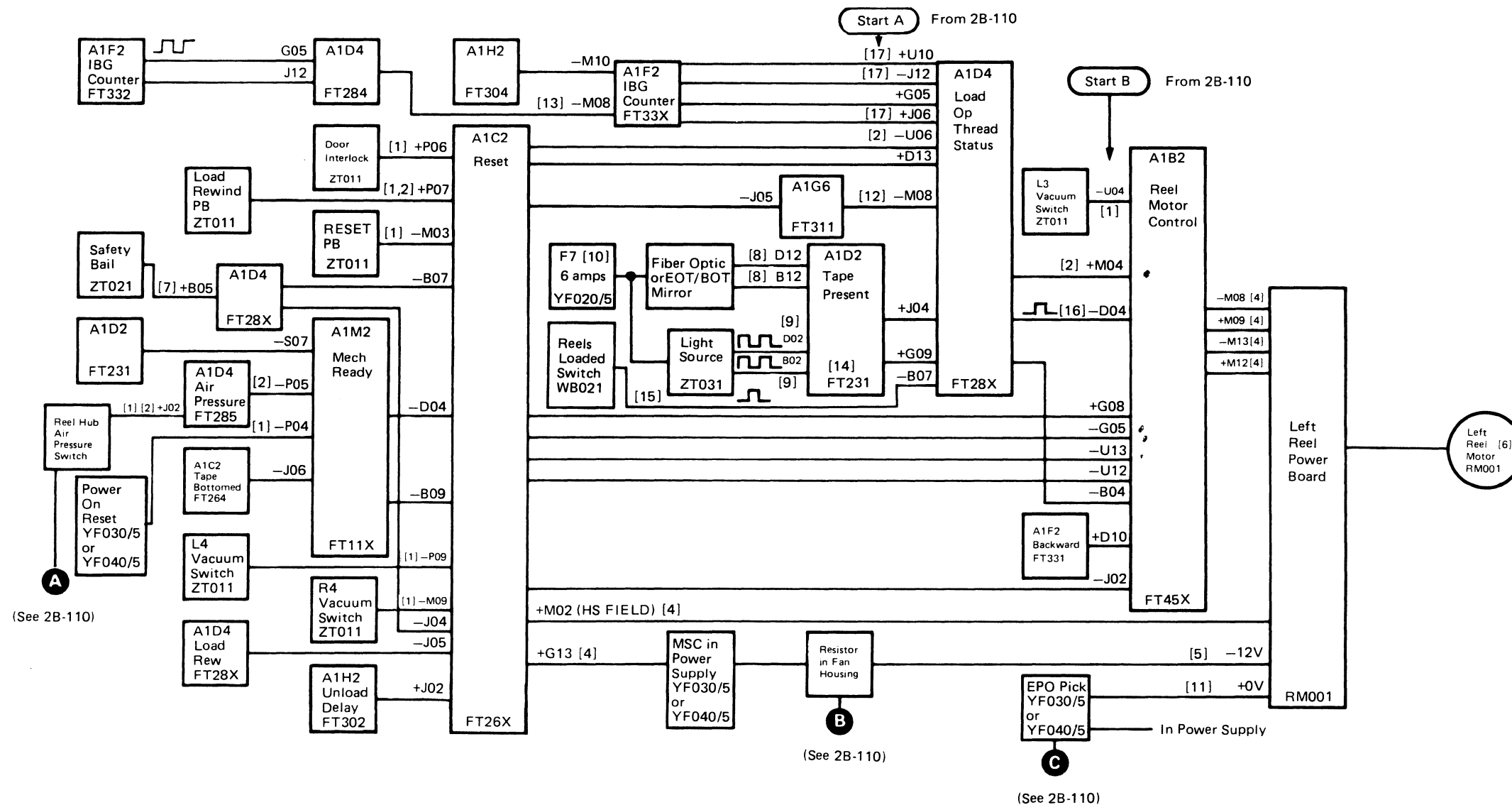

**Notes:**

- + Indicates nominal MST-1 plus (up) level of -0.85 Vdc; line should have solid up level or go to the up level.
- Indicates nominal MST-1 minus (down) level of -1.85 Vdc; line should have solid down level or go to the down level.
- [1] Plus (up) level is 0 Vdc and minus (down) level is -4 Vdc.
- [2] Level is checked with the LOAD REWIND pushbutton held pressed.

- [4] Plus (up) level is +12 Vdc and minus (down) level is 0 Vdc.
- [5] Measure at lower heat sink with motor plugged in. Voltage will be from -8 to -12 Vdc, depending on circuit load.
- Caution: Voltage switches to -48 Vdc when columns are loaded.**
- [6] Replace per "Left Reel Hub and Motor Removal/Replacement/Adjustment". See 08-000.

- [7] Plus (up) level is +6 Vdc and minus (down) level is 0 Vdc.
- [8] Typical voltage: +1.6 Vdc dark and less than +1.5 Vdc light.
- [9] Pulses from -1.3 Vdc to -1.6 Vdc.
- [10] For tape units with modified power interface board and power supply, see F1 on ALD YF040 (60 Hz) or ALD YF045 (50 Hz).
- [11] Measure at Reel Board J2-7.
- [12] Look at this line before Load Check occurs.
- [13] The T-A1F2M08 pin must display one plus pulse as beginning-of-tape (BOT) is sensed during thread.

- [14] If this level is incorrect, remove the tape. Perform the BOT/EOT adjustments before checking the T-A1D2 inputs. See 08-580 for the BOT/EOT adjustments.
- [15] Special voltage line is 0 Vdc when the tape covers the port. It is -4 Vdc when the reels are loaded port is uncovered.
- [16] Goes plus when loading or unloading.
- [17] With EC 846437 either U10 or J06 can be + level for proper operation and pin J12 is unused.

3803-2/3420

XC0500	2735782	See EC History	845958	846927	847298
Seq 1 of 2	Part Number		1 Sep 79	20 Jun 80	15 Aug 83

# RIGHT REEL DOES NOT TURN CLOCKWISE AT THE CORRECT SPEED

If right reel turns too fast or turns counterclockwise with tape unit unloaded, check K2 on the manual status control (MSC) card in the power supply (see ALD YC021). At interblock gap (IBG) Count 8, the right reel starts turning clockwise at half speed.

Conditions which prevent the right reel from turning are holding LOAD REWIND pressed, plus those conditions which prevent the left reel from turning. Holding the LOAD REWIND pushbutton deactivates the input to the IBG counter, preventing generation of IBG Count 8. If a Load Check occurs before reels are loaded, suspect extraneous pulses from radius sense photocell.

If the right reel slips, check the reel latch diaphragm. A diaphragm leak causes the reel to slip on the hub, and a serious diaphragm leak keeps the Latch Manifold Pressure switch from transferring, and the right reel will not turn. If the right reel turns too slowly, check the Pwr resistor housing connections at PRP1 (ALD ZT051). Also, check for an open resistor.

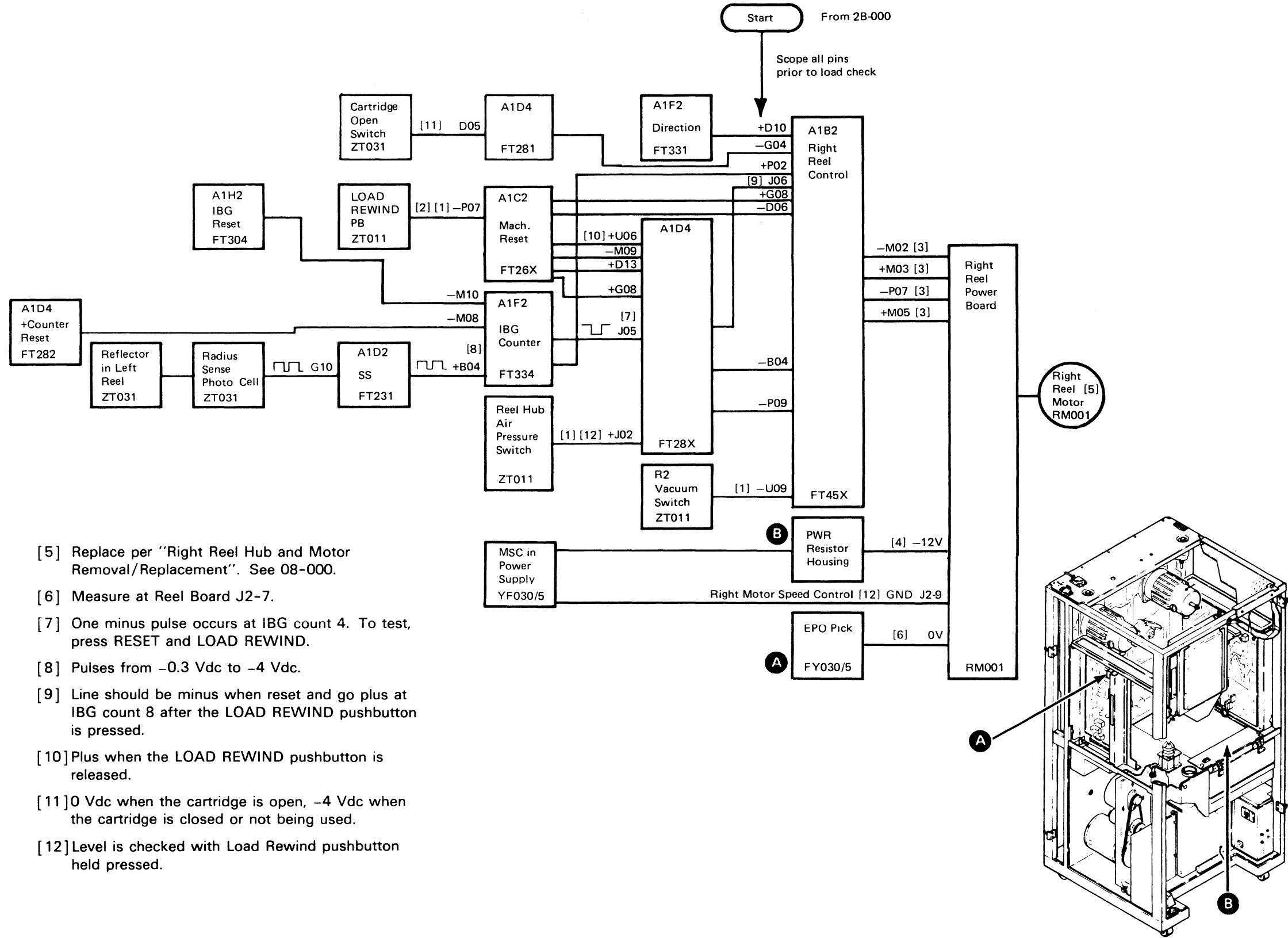

**Notes:**

- + Indicates nominal MST-1 plus (up) level of -0.85 Vdc; line should have solid up level or go to the up level.
- Indicates nominal MST-1 minus (down) level of -1.85 Vdc; line should have solid down level or go to the down level.
- [1] Plus (up) level is 0 Vdc and minus (down) level is -4 Vdc.
- [2] Level is checked without pressing LOAD REWIND pushbutton.
- [3] Plus level is +12 Vdc and minus level is 0 Vdc.
- [4] Measure at lower heat sink with motor plugged in. Voltage will be from -8 to -12 Vdc, depending on circuit load.
- [5] Replace per "Right Reel Hub and Motor Removal/Replacement". See 08-000.
- [6] Measure at Reel Board J2-7.
- [7] One minus pulse occurs at IBG count 4. To test, press RESET and LOAD REWIND.
- [8] Pulses from -0.3 Vdc to -4 Vdc.
- [9] Line should be minus when reset and go plus at IBG count 8 after the LOAD REWIND pushbutton is pressed.
- [10] Plus when the LOAD REWIND pushbutton is released.
- [11] 0 Vdc when the cartridge is open, -4 Vdc when the cartridge is closed or not being used.
- [12] Level is checked with Load Rewind pushbutton held pressed.

**Caution: Voltage switches to -48 Vdc when columns are loaded.**

3803-2/3420

XCO500	2735782	See EC History	845958	846927	847298		
Seq 2 of 2	Part Number		1 Sep 79	20 Jun 80	15 Aug 83		

© Copyright International Business Machines Corporation 1976, 1979, 1980, 1983



# TAPE THREADS TRANSFER INTO RIGHT COLUMN (TRANSFER VALVE NOT PICKED OR PNEUMATIC MOTOR NOT RUNNING)

Load Op activates Pick Air Supply Cont (ALD FT282), which energizes contactor K1 located in the power supply. K1 supplies ac power to the pneumatics motor that drives the pressure pump and vacuum blower.

Thread Status (ALD FT284) actuates the transfer valve, which switches vacuum and directs pressure to the threading channels, preventing vacuum in the columns. Check transfer valve action by watching the transfer valve solenoid plunger from the rear of the machine.

- If the transfer valve is operating and there is still vacuum in the columns, see 08-400 Transfer Valve Leakage Test.
- If the transfer valve solenoid is not operating, check CP3 at the rear of the machine.

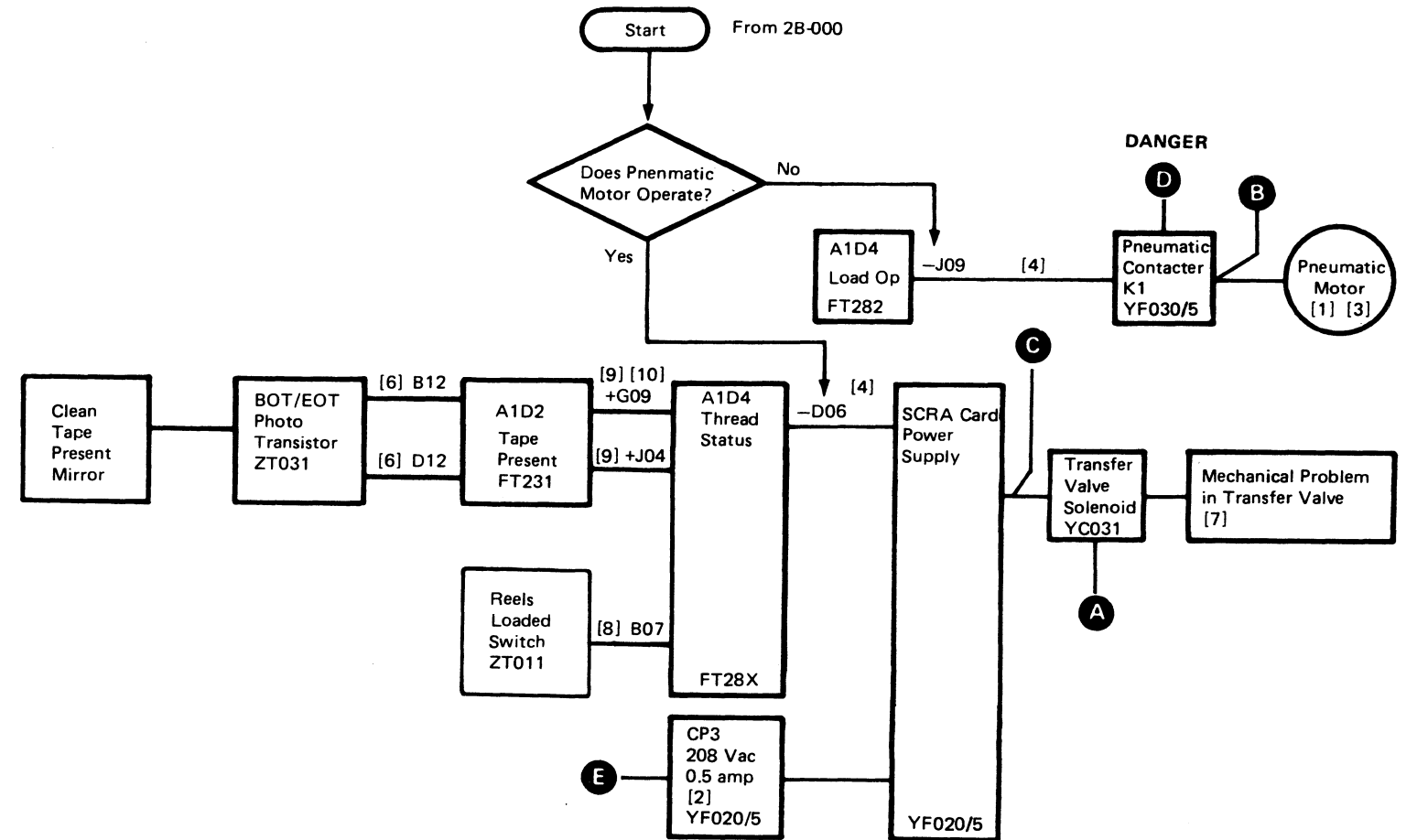
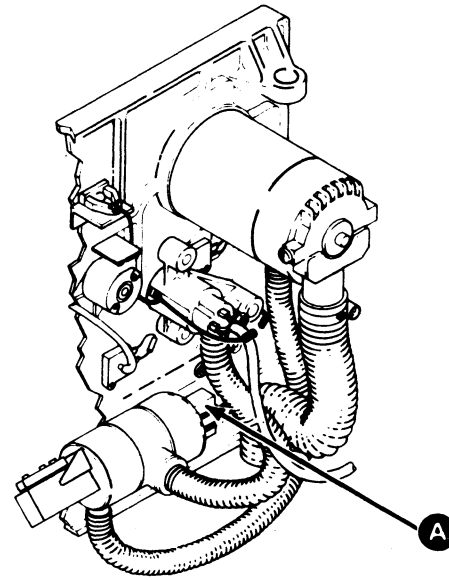

## Power Supply

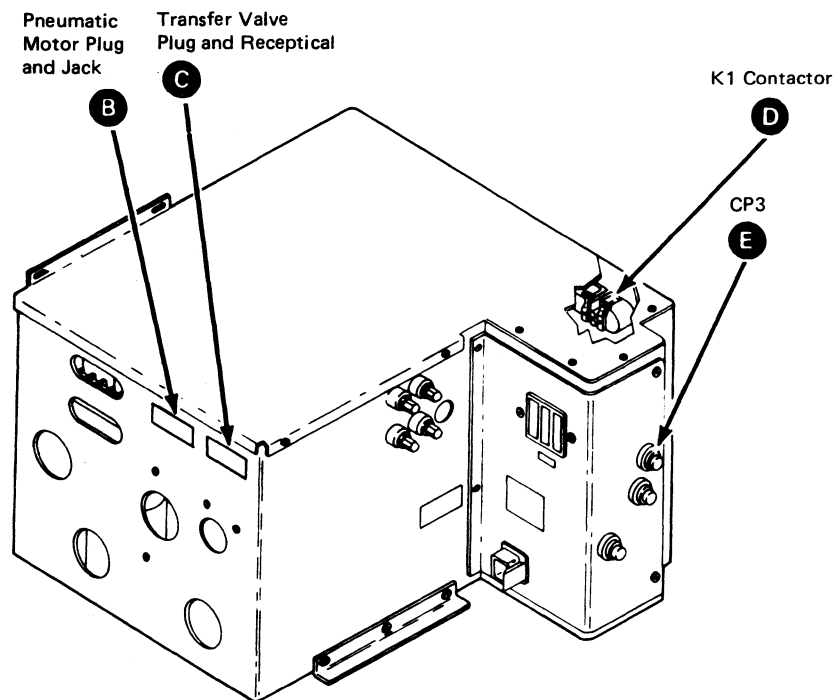

### Notes:

- + Indicates nominal MST-1 plus (up) level of -0.85 Vdc; line should have solid up level or go to the up level.
- Indicates nominal MST-1 minus (down) level of -1.85 Vdc; line should have solid down level or go to the down level.
- [1] See ALD YF030 (60 Hz) or ALD YF035 (50 Hz).
- [2] CP3 is non-indicating and is not monitored by power check circuits.
- [3] Replace per "Pneumatic Supply Belt Replacement/Adjustment". See 08-000.
- [4] Special voltage levels: Up level = +12 Vdc; down level = 0 Vdc.
- [6] Typical voltage levels: +1.6 Vdc dark and less than +1.5 Vdc light.
- [7] Check for leakage (see Transfer Valve Leakage Test on 08-400).
- [8] Unload the tape unit and remove the tape reel. Press and hold the LOAD REWIND pushbutton to force and hold Thread Status. Cover and uncover the Reels loaded port. The reading should be 0 Vdc covered and -4 Vdc uncovered.
- [9] If the level is incorrect, remove the tape. Perform (BOT/EOT) adjustments (see 08-580) before checking the T-A1D2 inputs.
- [10] Special voltage: 0 Vdc to -4 Vdc.

### DANGER

Power must be removed completely. Remove the power cord when servicing inside the AC box.

3803-2/3420

XC0600	2735783	See EC	845958	846927	847298		
Seq 1 of 2	Part Number	History	1 Sep 79	20 Jun 80	15 Aug 83		

© Copyright International Business Machines Corporation 1976, 1979, 1980, 1983

# TAPE STARTS INTO THREADING CHANNEL AND STOPS

The transfer valve remains actuated by Thread Status (ALD FT284) for one revolution after the beginning-of-tape (BOT) marker is sensed.

1. Obstructions in the read/write head area. Check the alignment of the autocleaner assembly. (See 08-000).
2. Left reel turning too fast. See 2B-110.
3. Load check is set when the tape threads to the read/write head. Check for a defective Reels Loaded switch.
4. Threading pressure or vacuum may be missing or low. See "Threading Pressure and Vacuum Checks". See 08-000.
5. Tape may stick to lower restraint due to static.

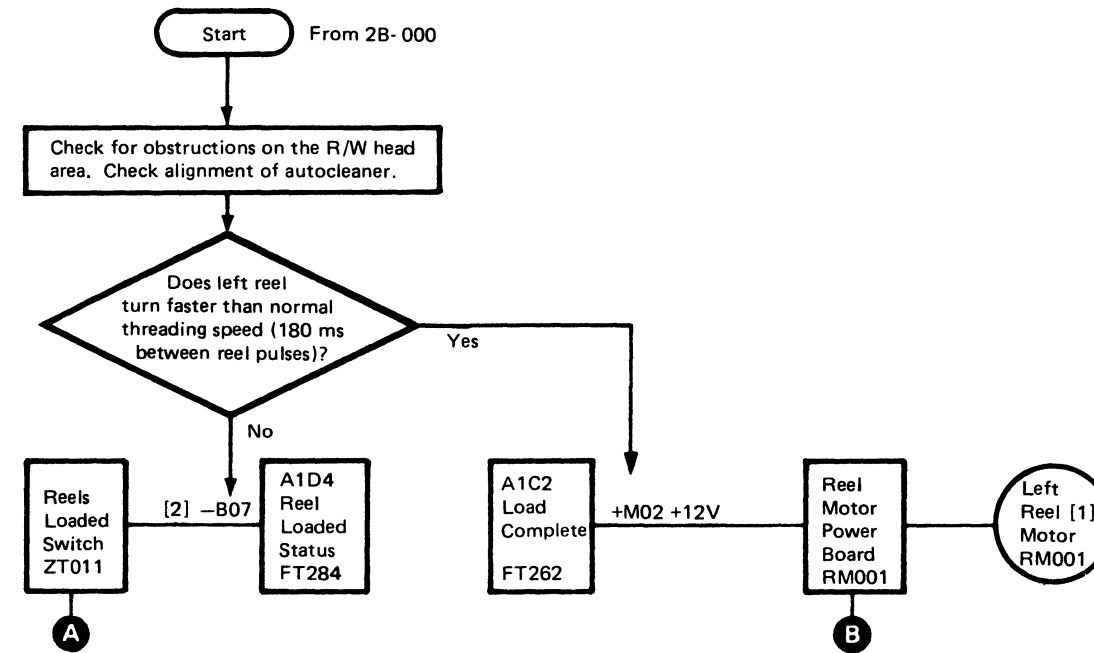

**Notes:**

- + Indicates nominal MST-1 plus (up) level of -0.85 Vdc; line should have solid up level or go to the up level.
- Indicates nominal MST-1 minus (down) level of -1.85 Vdc; line should have solid down level or go to the down level.

[1] Replace per "Left Reel Hub and Motor Removal/Adjustment". See 08-000.

[2] Special voltage levels: -4 Vdc to ground. Line is at ground level only when tape covers the Reels Loaded switch sensing port. Line is at -4 Vdc level when the tape unit is unloaded, or has tape loaded in columns.

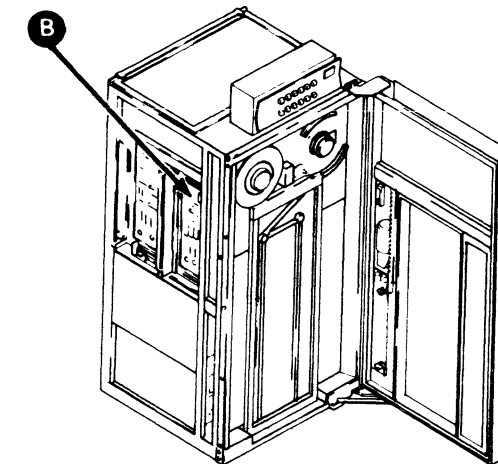
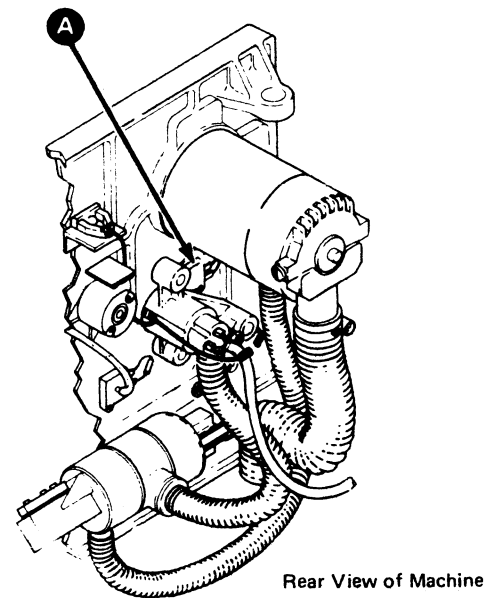

3803-2/3420

XC0600	2735783	See EC History	845958	846927	847298			
Seq 2 of 2	Part Number		1 Sep 79	20 Jun 80	15 Aug 83			

© Copyright International Business Machines Corporation 1976, 1979, 1980, 1983

# LOAD CHECK PRIOR TO BEGINNING-OF-TAPE (BOT) SENSE

A Load Check (ALD FT28X) can be due to the IBG counter stepping incorrectly or the BOT/EOT sensors failing.

A slight tension develops when tape is firmly wrapped around the left reel with the right reel turning at half speed. Tension raises the tape and blocks the reels loaded sensing port, activating the Reels Loaded switch.

Excessive leader length will cause a load check during a retry.

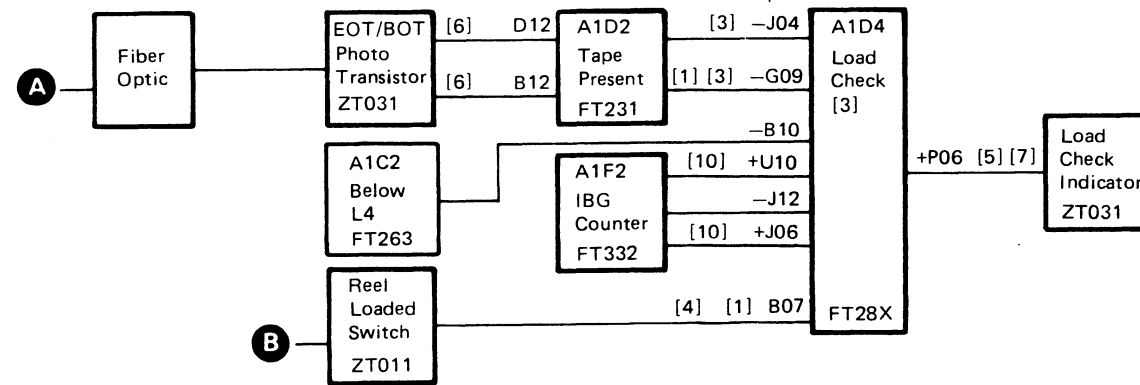
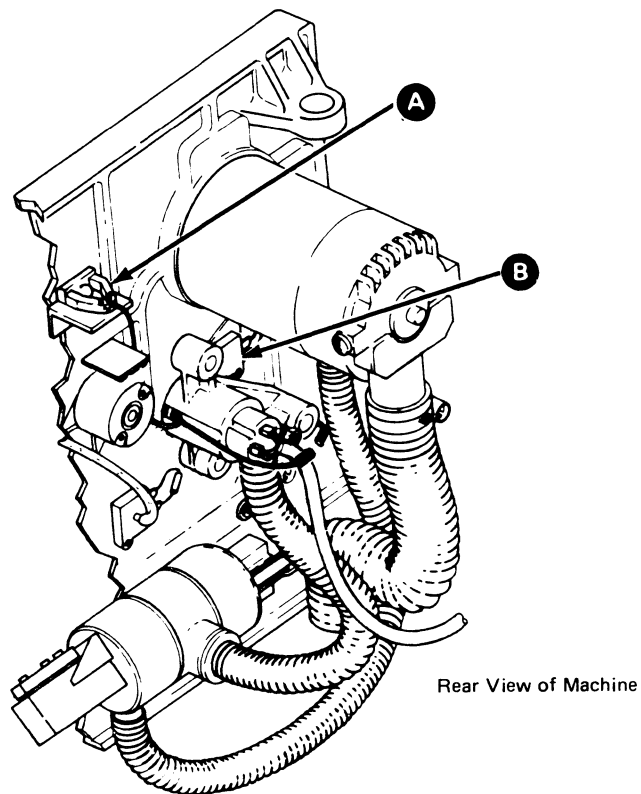
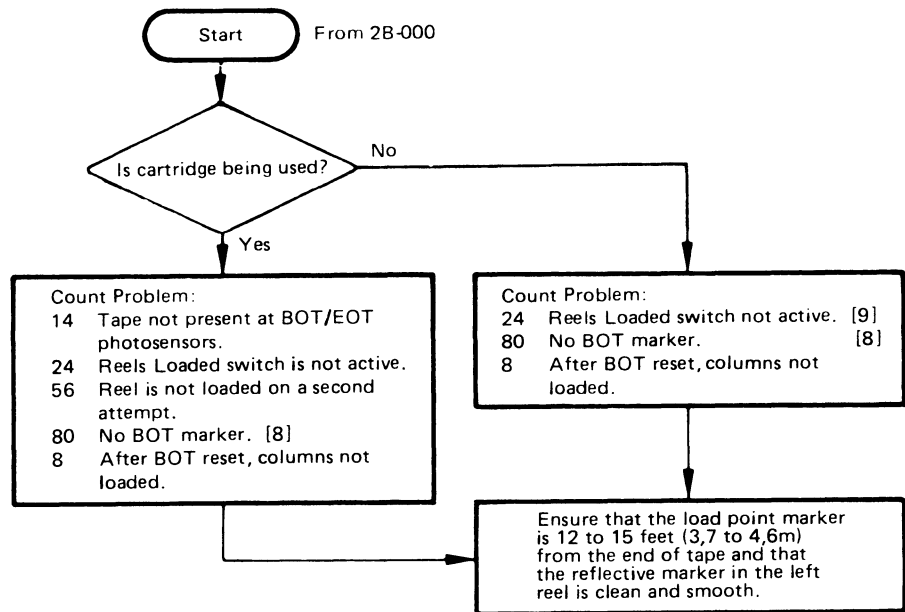

**Notes:**

- + Indicates nominal MST-1 plus (up) level of -0.85 Vdc; line should have solid up level or go to the up level.
- Indicates nominal MST-1 minus (down) level of -1.85 Vdc; line should have solid down level or go to the down level.
- [1] Plus (up) level is 0 Vdc and minus (down) level is -4 Vdc.
- [3] If this level is incorrect, remove the tape. Perform the BOT/EOT adjustments (See 08-580) before checking the T-A1D2 inputs.
- [4] Line must go to 0 Vdc during threading operation. Line goes to -4 Vdc when pneumatics drop.
- [5] Special voltage levels: 0 Vdc to +12 Vdc.
- [6] Typical voltage levels: +1.6 Vdc dark and less than +1.5 Vdc light.
- [7] Plus if Load Check indicator is off.
- [8] 72 without EC 846437.
- [9] 18 without EC 846437.
- [10] With EC846437 either U10 or J06 can be + level for proper operation and pin J12 is unused.

3803-2/3420

XC0700 Seq 1 of 2	2735784 Part Number	See EC History	845958 1 Sep 79	846927 20 Jun 80	847298 15 Aug 83			
----------------------	------------------------	-------------------	--------------------	---------------------	---------------------	--	--	--

© Copyright International Business Machines Corporation 1976, 1979, 1980, 1983



Tape bottoms in or pulls out of columns, or exhibits abnormal motion (bobbles).

Tape loads into the column after the 670 ms singleshot times out, putting the reels under complete column control. Columns Loaded Status and Load Complete (ALD FT26X) are set with the tape above R4 and L4 vacuum switches and below R1 and L2 vacuum switches. Load Complete conditions Go Internal for a low speed rewind back to Load Point under capstan control (ALD FT331). Make sure the vacuum door is tightly closed while loading.

**Set Up Procedure**

1. Check to ensure that the right reel is not slipping on the hub with columns loaded.
2. Clean the capstan.

**Caution: Do not let the tape touch the capstan under any circumstance, or the capstan may be severely damaged during the following procedure.**

3. Tape a short strip of magnetic tape in each column so it forms a loop in the middle of the column. In the right column route the tape strip between the tape cleaner block and the erase head to keep light from the BOT/EOT photocells. In the left column route the tape strip to the underside of the upper stubby bar to bypass the capstan. Seal the Reels Loaded port with a piece of transparent or masking tape.
4. With power up, press LOAD REWIND. Press RESET twice, and then START.
5. Press RESET, LOAD REWIND, and START again. The Ready light should not come on. If it does, replace T-A1G2.

6. After setting up the tape unit, scope the capstan tach output on T-A1H2G09. Tach periods are as follows:

Model 4 = 61 microsecond  
 Model 6 = 56 microsecond  
 Model 8 = 47 microsecond  
 (All timings are ±4%)

- If the tach period is out of tolerance, go to 6B-000.
- If the output is not pulsing, go to 2B-175.
- If tach periods are satisfactory, begin at start on this page.

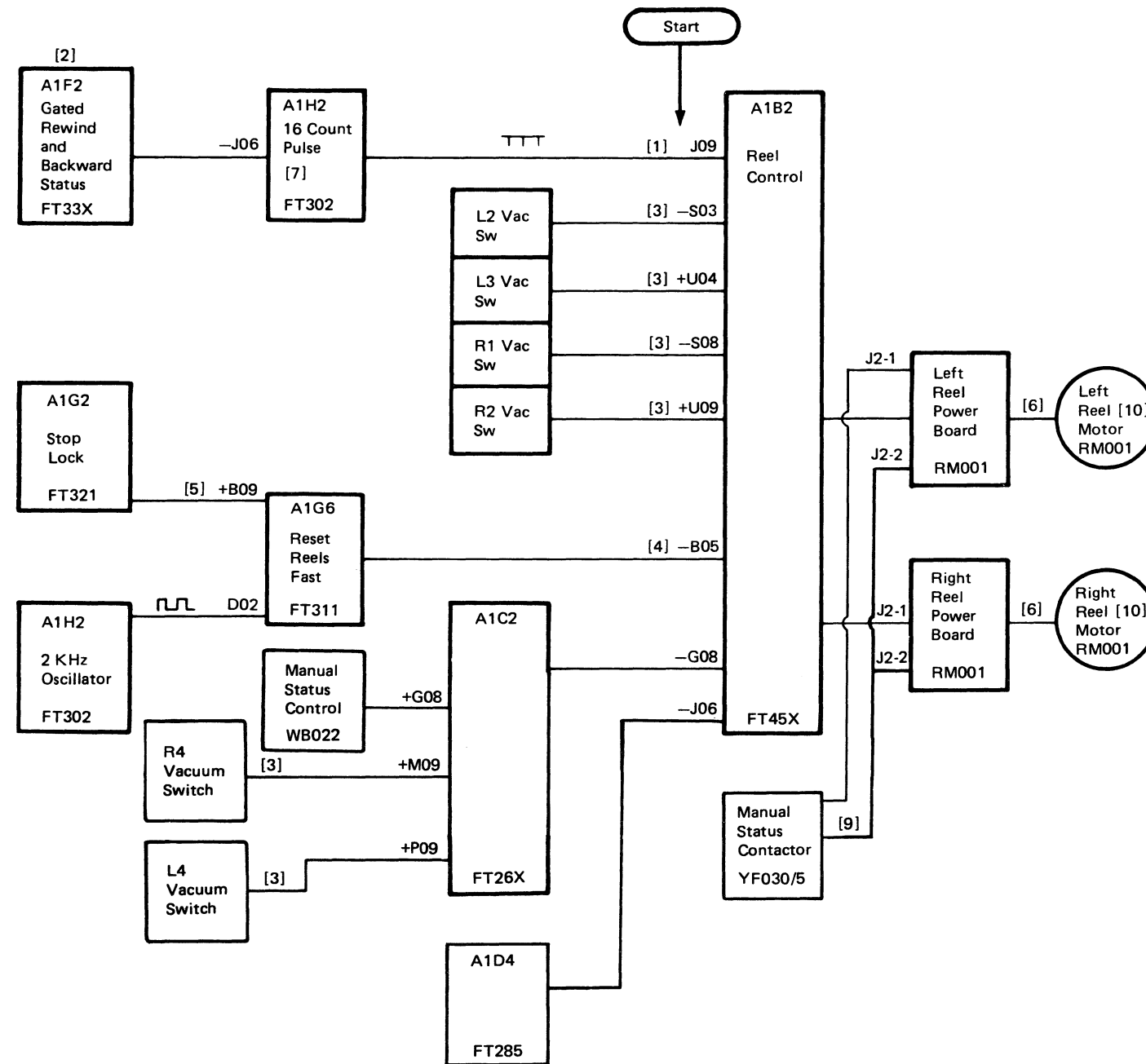

**Notes:**

- + Indicates nominal MST-1 plus (up) level of -0.85 Vdc; line should have solid up level or go to the up level.
  - Indicates nominal MST-1 minus (down) level of -1.85 Vdc; line should have solid down level or go to the down level.
- [1] Negative pulses 500 ns (±10%) in duration.  
 Model 4-0.98 milliseconds between pulses  
 Model 6-0.90 milliseconds between pulses  
 Model 8-0.75 milliseconds between pulses  
 Press the RESET pushbutton. Pulses should disappear. Press LOAD REWIND and START pushbuttons before continuing.
  - [2] If changing A1F2 does not solve the problem, go to 6B-000.
  - [3] Manually pass tape across the switch ports to check switch operation, 0 Vdc above and -4 Vdc below the ports. Levels are shown for tape in the middle of the columns.
  - [4] Press the RESET pushbutton. Level should pulse and then go plus. Press LOAD REWIND and START pushbuttons before continuing.
  - [5] Press the RESET pushbutton. Level should go minus. Press LOAD REWIND and START pushbuttons before continuing.
  - [6] Right and left reel power boards may be switched if they are the same part number. Check plugging.
  - [7] If changing T-A1H2 does not solve your problem, go to 6B-000.
  - [9] J2-2 is -12 Vdc with drive loaded and 0 volts if unloaded. J2-1 is -12 Vdc while drive is unloaded or threading and -45 Vdc with drive loaded and reel motor not being driven.
  - [10] See 08-000 for replacement.

3803-2/3420

XCO800	2735785	See EC History	845958	847298				
Seq 1 of 2	Part Number		1 Sep 79	15 Aug 83				

© Copyright International Business Machines Corporation 1976, 1979, 1983

NOTES:

2B-171

3803-2/3420

XC0800	2735785	See EC	845958	847298				
Seq 2 of 2	Part Number	History	1 Sep 79	15 Aug 83				

© Copyright International Business Machines Corporation 1976, 1979, 1983

2B-171

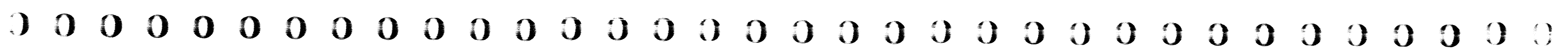







# TAPE MOVES BACKWARD OFF LEFT REEL, OR TAPE UNIT PERFORMS A NORMAL UNLOAD REWIND DURING LOAD OPERATION

Beginning-of-tape (BOT) single shot (SS) sets Load Point Status (ALD FT324) which resets Go Internal and Extended Go. Tape motion should then stop.

Ensure that a BOT marker is located 12 to 15 feet (3.6 to 4.7m) from the beginning of the tape.

If tape unit did a normal unload, use Start A. Use Start B if tape moved backward off left reel.

## SET UP PROCEDURE

1. Install tape loops as on 2B-170.
2. Press RESET. Press LOAD REWIND twice, then START. Then press RESET and LOAD REWIND.

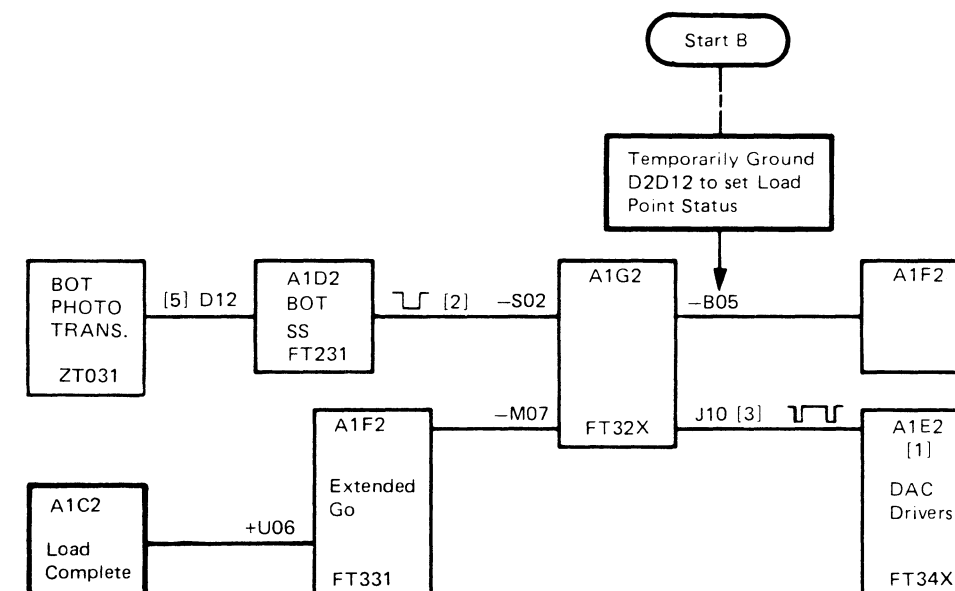
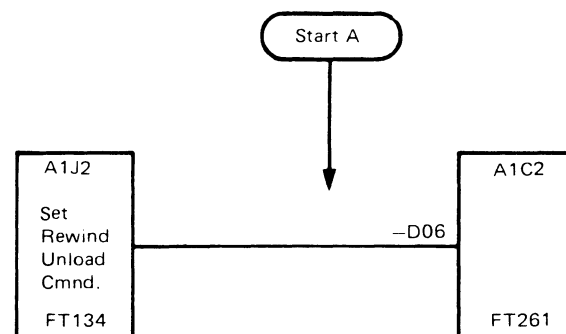

### Notes:

- + Indicates nominal MST-1 plus (up) level of -0.85 Vdc; line should have solid up level or go to the up level.
- Indicates nominal MST-1 minus (down) level of -1.85 Vdc; line should have solid down level or go to the down level.
- [1] Do not replace T-A1E2 at this time. Go to 6B-000.
- [2] This pulse only visible when BOT SS fires. Momentarily ground T-A1D2D12.
- [3] To test this line, set tester for Fwd, St/Stp. Operate START to make tape unit ready.
- [5] Typical voltage: +1.6 Vdc dark and less than +1.5 Vdc light.

3803-2/3420

XC0900 Seq 1 of 2	2735786 Part Number	See EC History	845958 1 Sep 79	847298 15 Aug 83				
----------------------	------------------------	-------------------	--------------------	---------------------	--	--	--	--

© Copyright International Business Machines Corporation 1976, 1979, 1983

# TAPE GOES FORWARD AFTER LOADING INTO VACUUM COLUMNS

If the tape goes forward after loading into columns, Backward Status (ALD FT134) was not set.

### NORMAL SEQUENCE:

- 1 Beginning-of-tape (BOT) single shot (SS) and four interblock gap (IBG) counts resets Thread Status.
2. The BOT SS sets Load Rewind Status (ALD FT282), which activates Rewind Op.
3. Rewind Op then sets Backward Status, causing the tape to move backwards.

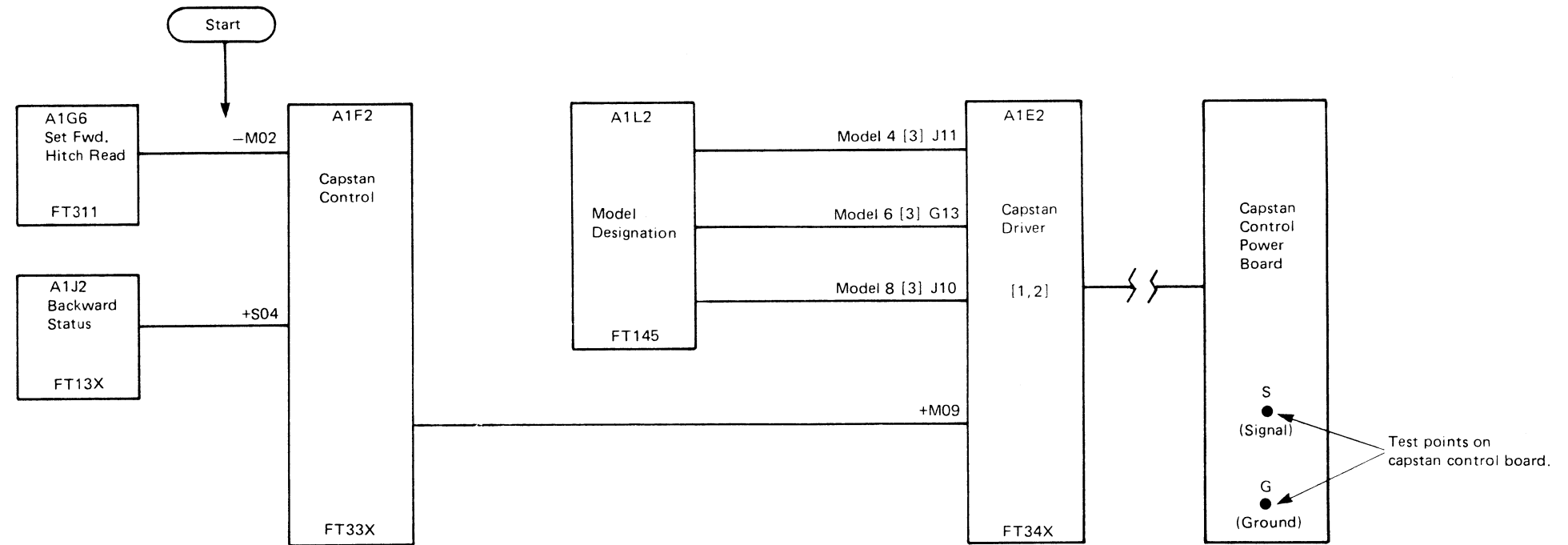

### Notes:

- + Indicates nominal MST-1 plus (up) level of  $-0.85$  Vdc; line should have solid up level or go to the up level.
  - Indicates nominal MST-1 minus (down) level of  $-1.85$  Vdc; line should have solid down level or go to the down level.
- [1] Replace the capstan control power board, then T-A1E2.
  - [2] If the problem is still not fixed, go to 6B-000.
  - [3] Line is minus for model being tested, otherwise it is plus.

3803-2/3420

XC0900	2735786	See EC History	845958	847298				
Seq 2 of 2	Part Number		1 Sep 79	15 Aug 83				

© Copyright International Business Machines Corporation 1976, 1979, 1983

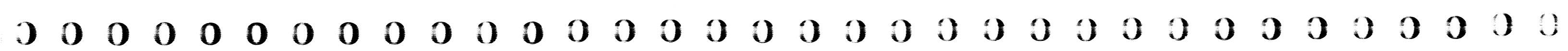

**NORMAL OPERATION**

- Load Complete resets Load Op (ALD FT284).
- Load Complete is gated by Mech Rdy and Columns Loaded Status keeps the pneumatic supply motor running.
- Pressing the START pushbutton sets the Ready latch.
- The Ready latch, gated by Window Closed, turns on the READY indicator.

**SET UP**

1. Mount tape.
2. Press the LOAD REWIND pushbutton, then the START pushbutton.
3. Read Note [9].

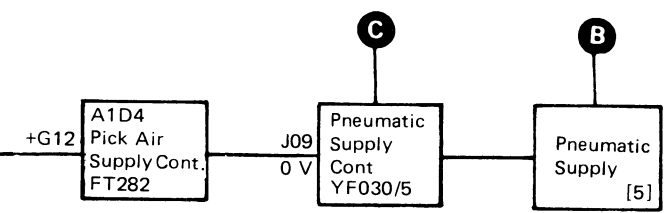
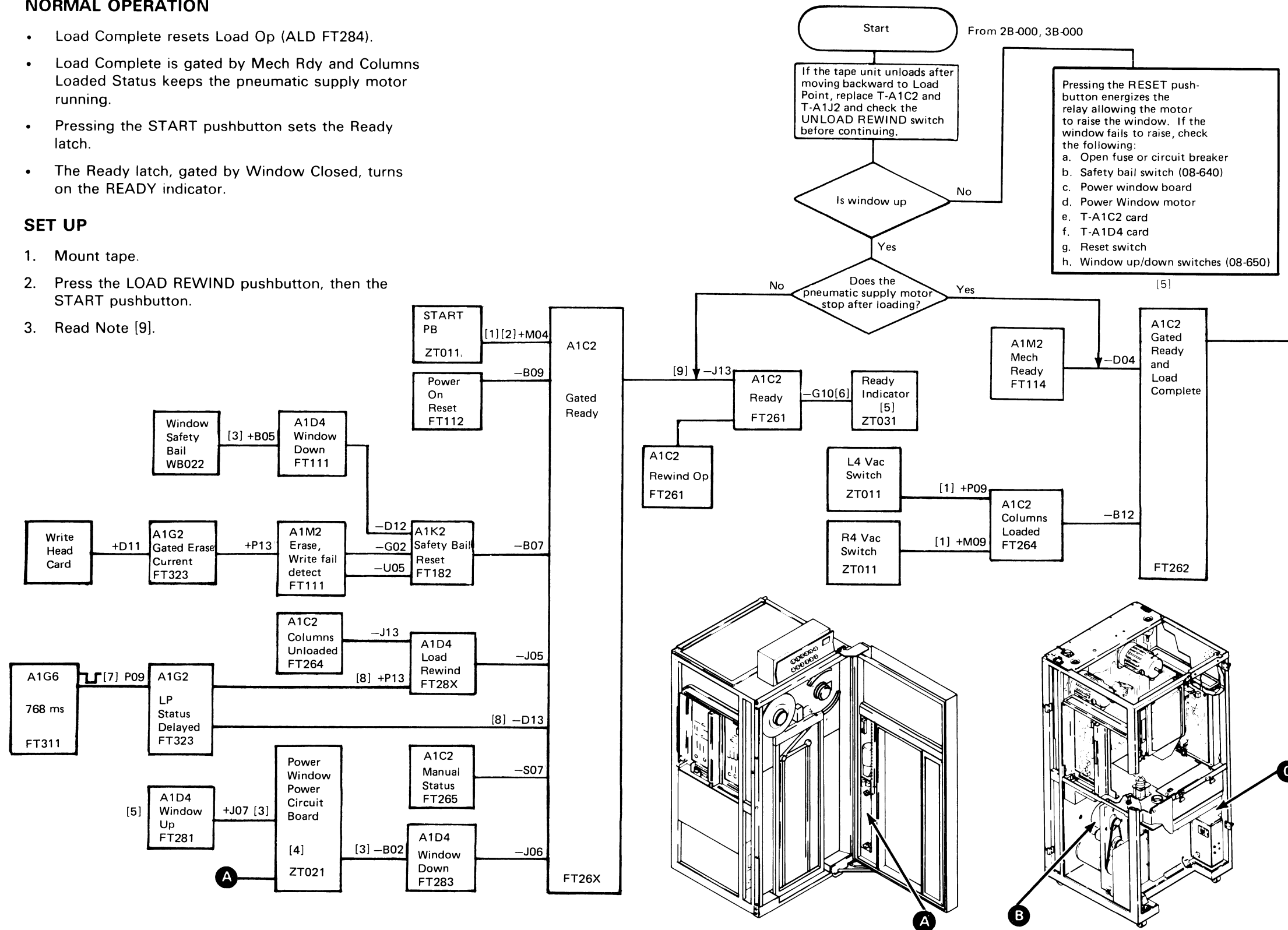

- Notes:**
- + Indicates nominal MST-1 plus (up) level of -0.85 Vdc; line should have solid up level or go to the up level.
  - Indicates nominal MST-1 minus (down) level of -1.85 Vdc; line should have solid down level or go to the down level.
- [1] Plus (up) level is +0 Vdc and minus (down) level is -4 Vdc.
  - [2] Test with START pushbutton pressed.
  - [3] Up level is +6 Vdc and down level is 0 Vdc.
  - [4] Check fuse, Up and Down switches, relay, power window circuit board, and motor.
  - [5] If problem is not fixed, suspect missing or out of tolerance power supply voltage.
  - [6] Minus level is 0 Vdc to +0.5 Vdc; plus level is +12 Vdc.
  - [7] Unload tape unit; look for a minus pulse during a load operation.
  - [8] Ignore the state of these lines if tape did not initially rewind to load point. Check T-A1D2D11 for +4.2 Vdc or greater. If not go to 08-580.
  - [9] Press and hold the START pushbutton. If the output of Gated Ready (T-A1C2J13) pulses, check the operation of the File Protect mechanism, NFP-1 pressure switch, Write Enable Relay assembly, and air pressure. Improper or intermittent operation of the File Protect mechanism or associated circuits during a write operation will cause ERASE CURRENT or WRITE CURRENT failures which will reset READY status. If the output of Gated Ready does not pulse, continue with the procedure.

3803-2/3420	XC1000	2735787	See EC History	845958	846927	847298		
Seq 1 of 2	Part Number			1 Sep 79	20 Jun 80	15 Aug 83		

NOTES:

2B-211

3803-2/3420

XC1000 Seq 2 of 2	2735787 Part Number	See EC History	845958 1 Sep 79	846927 20 Jun 80	847298 15 Aug 83			
----------------------	------------------------	-------------------	--------------------	---------------------	---------------------	--	--	--

© Copyright International Business Machines Corporation 1976, 1979, 1980, 1983

2B-211



# TAPE MOTION AND REWIND SYMPTOMS

3B-000

From 00-040, 2B-000.		
<b>Most Probable Causes:</b>		
<ul style="list-style-type: none"> <li>• Defective transfer valve.</li> <li>• Leakage in pneumatic system.</li> <li>• Capstan squaring.</li> <li>• Low pressure or vacuum.</li> <li>• Defective card at: T-A1J2, T-A1K6, T-A1C2, or T-A1G2.</li> </ul>		
For operational overview see Theory section (3B-010 and 3B-020).		
Always start with Seq 1 and follow the procedure in sequence unless directed otherwise. Remember to END all problems or maintenance calls by going to MAP 00-030.		
Seq	Condition/Instruction	Action
1	Set up field tester for Write, Fwd, and Go. See 80-020 for reference.	
2	Does tape move forward properly?	Go to Seq 5.
3	Does tape make no response or move backward without bottoming or pulling out on a forward operation?	Go to 3B-100.
4	If not:	Go to 3B-110.
5	Change field tester settings from Go to Stop.	
6	Does tape stop?	Go to Seq 8.
7	If not:	Go to 3B-140.
8	Set up field tester for Read, Bkwd, and Go. Make sure tape is away from load point.	
9	Does tape move backward properly?	Go to Seq 12.
10	Does tape fail to go backward?	Go to 3B-130.
11	If not:	Go to 3B-110.
12	Change field tester setup to Read, Fwd, and Go.	
13	Does tape go forward?	Go to Seq 15.
14	If not:	Go to 3B-100.
15	Read the complete reel of tape. Does SELECT indicator go out and tape motion stop at the end-of-tape (EOT) marker?	Go to Seq 18.
16	Does tape unwind off the end of the right reel?	Go to 3B-150.
17	If not:	Recheck symptoms. Go to 00-030.
18	Change field tester setup to Reset, Load Rewind, and Start.	
19	Does the tape move backward?	Go to Seq 21.
20	If not:	Replace T-A1C2, T-A1J2, and T-A1K6. Go to 00-030.

Seq	Condition/Instruction	Action
21	Do the Ready and the TI indicators go out?	Go to Seq 24.
22	Does the READY indicator stay on?	Go to 4B-000, Start B.
23	If not:	Go to 3B-150.
24	Does the tape bottom, bobble, or pull out of the left column?	Go to 3B-110.
25	Does tape enter and stabilize at high speed during high speed rewind?	Go to Seq 27.
26	If not:	Go to Seq 32.
27	Does tape pull out of the stubby column when going from a high speed to a low speed rewind? See Figure 1.	Go to 6B-150
28	After finishing high speed rewind, does the tape rewind to the beginning-of-tape (BOT)?	Go to Seq 30.
29	If not:	Go to Seq 32.
30	Does tape stop at BOT with READY indicator On?	Go to Seq 37.
31	If not:	Go to 2B-210.
32	Does tape pull out of, dump, or move with wide excursions in the left column?	Go to 3B-160.
33	Does tape enter and stay in high speed rewind?	Go to Seq 35.
34	If not:	Go to 3B-170.
35	Does tape rewind to BOT at high speed or rewind off the left reel?	Go to 3B-180.
36	If not:	Recheck symptoms.
37	Set up field tester for Write, Fwd, and St/Stp.	
38	Does tape move forward properly?	Go to Seq 41.
39	Does tape make no response or move backward on a forward operation?	Go to 3B-100.
40	If not:	Go to 6B-000.
41	Change tester to Read, Bkwd, and St/Stp.	
42	Does tape move backward properly?	Go to 00-030.
43	Does tape move backward?	Go to 6B-000.
44	If not:	Go to 3B-130.

Figure 1. Normal

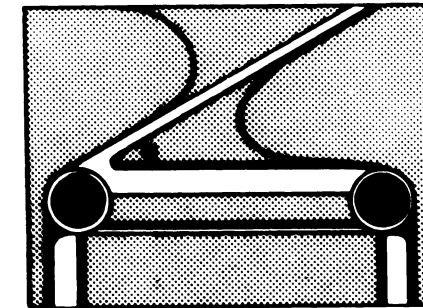

Figure 1 indicates normal tape position in the stubby columns while tape is moving forward or backward. Variations of one-half inch (1,3 cm) between forward and backward is normal.

3803-2/3420

XC1100	2735788	See EC History	845958	846927				
Seq 1 of 2	Part Number		1 Sep 79	20 Jun 80				

© Copyright International Business Machines Corporation 1976, 1979, 1980

3B-000

# REWIND OPERATION

3B-010

The tape reels turn backward at either high or low speed, until tape is rewound on the right reel. The operation ends when a photocell senses the beginning-of-tape (BOT) (load point) reflective marker. A low speed rewind occurs when there is less than one-half inch (12.7 mm) of tape on the left reel and tape moves backward to load point at approximately 200 ips (5.0 m/sec). A high speed rewind moves tape backward at approximately 500-600 ips (12.7-15.2 m/sec) for Models 4 and 6, and approximately 700-800 (17.8-20.3 m/sec) ips for Model 8 until less than one-half inch (12.7 mm) of tape remains on the left reel. Rewind then continues at low speed until the load point is reached.

A rewind operation is started by a Rewind command from the tape control or by pressing the UNLOAD REWIND or LOAD REWIND pushbutton when the tape unit is not ready.

A rewind operation starts with a forward motion if tape has not moved for 12 milliseconds or longer. In this instance, the capstan moves tape forward for 8 quarter tach counts, reverses direction, and accelerates to normal backward velocity.

The left reel turns counterclockwise to feed tape into the left column when the left column loop goes above the L2 port. The right reel turns counterclockwise to take up slack from the right column when the right column loop goes below the R2 port.

The High Speed Field latch is set after both the right reel and the left reel have exceeded the capstan speed. The High Speed Field latch holds the Polarity Hold Drive (PHD) register reset. When the PHD register is reset, the capstan is controlled by Rewind Current and Step Down Current.

During high speed rewind, Rewind Current and Step Down Current are controlled by the reel/capstan speed comparison circuit.

High speed rewind ends when enough tape is removed from the left reel to activate the left radius sense phototransistor, which, activates Step Down. During stepdown, the capstan speed follows the speed of the reel which starts to slow down first, until the capstan drops below normal velocity. Capstan motion then continues under normal control until the BOT marker is reached.

Pressing RESET also activates Step Down. Holding RESET pressed or pressing RESET a second time stops the tape.

Rewind Timing Chart (Models 4, 6, and 8)

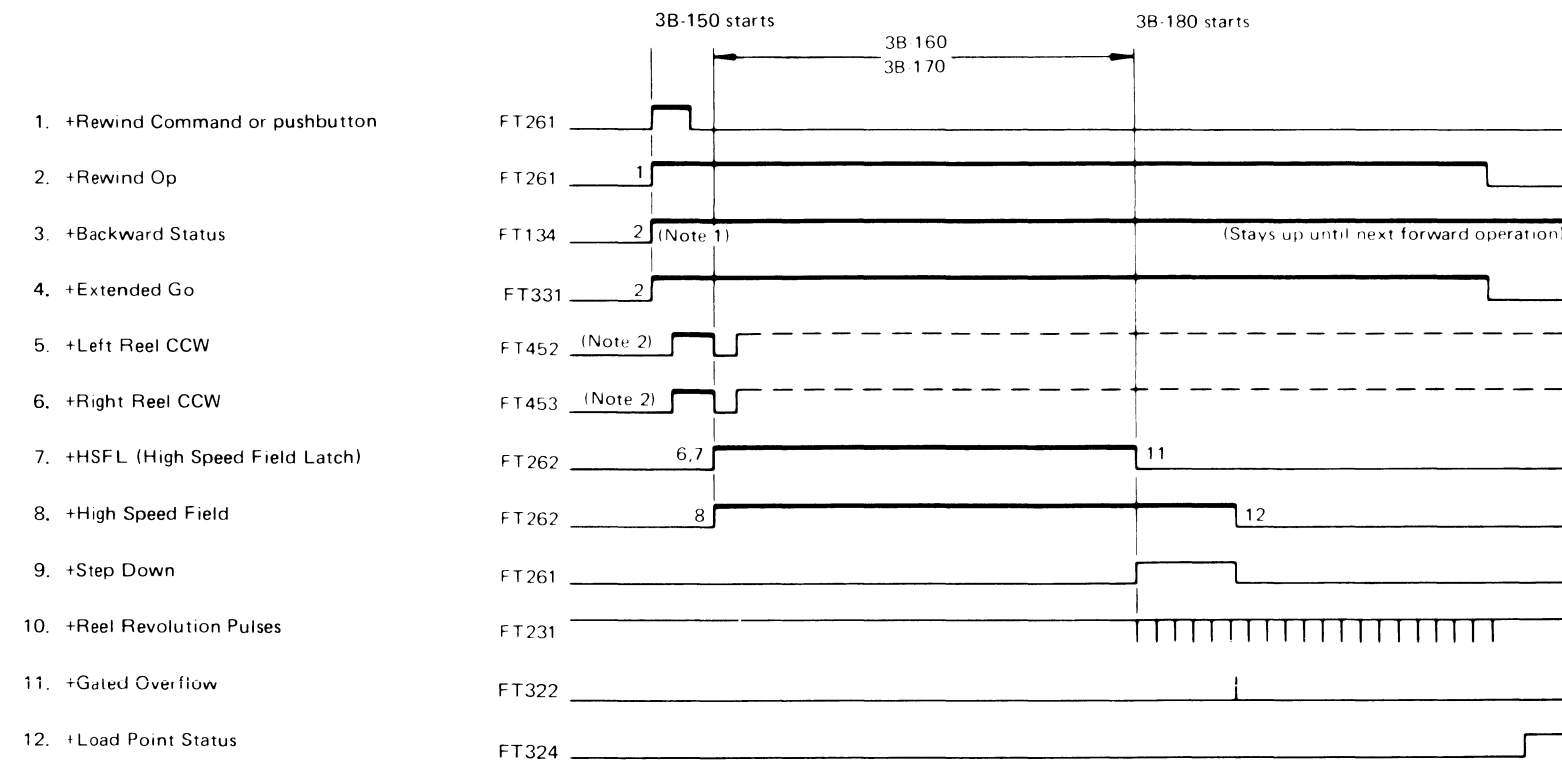

**Notes:**

1. If EXTENDED GO is down for 12 milliseconds or more, tape motion starts with a forward movement.
2. Activated by vacuum column switch sensing.

3803-2/3420

XC1100 Seq 2 of 2	2735788 Part Number	See EC History	845958 1 Sep 79	846927 20 Jun 80			
----------------------	------------------------	-------------------	--------------------	---------------------	--	--	--

© Copyright International Business Machines Corporation 1976, 1979, 1980

3B-010



# REEL DRIVE SYSTEM

The reel drive system includes:

- Reel motors and drivers
- Reel stabilization circuits
- Reel tachometers (reel tachs)
- Vacuum sensing switches

The reel drive system operates in Manual Status to thread, load, and unload the tape unit. It operates in Not Manual Status for all other operations. Manual Status is identified in the tape unit by the Manual Status line.

Reels supply tape to and remove tape from the vacuum columns under control of the vacuum column switches. These vacuum column switches sense the tape position and initiate reel motion. The capstan moves tape which causes reel motion.

## REEL MOTORS AND DRIVERS

The reel motors run at three different speeds, which are varied by changing the armature and field voltages.

Speed	Voltages	Function
Low	Armature -12 Field -45	Manual operations: load, thread, unload
Normal	Armature -45 Field -45	Read, write, slow speed rewind
High	Armature -45 Field -6	High speed rewind

The direction (polarity) of the armature current determines motor direction.

The reel motors can be in proportional drive, proportional coast, or brake status moving at any speed in either direction. A motor is in proportional drive status when current is passing through the armature. A motor is in proportional coast status when no current is passing through the armature. A motor is in brake status when the armature is short circuited (both sides of the armature grounded).

## REEL STABILIZATION

Column vacuum tends to pull the tape loop toward the bottom of the straight columns when the tape unit is loaded and stopped. To overcome this force, -12 volts (reel anti-bobble voltage) is applied to each reel motor armature to produce an opposing torque.

## REEL TACHOMETER

The reel tachs are phototransistors in the idlers above each vacuum column. The phototransistor output pulse is squared by the reel squaring circuit. The reel/capstan comparison circuit compares the squared reel tach pulse with the output of the 16 count generator, which generates one pulse for every 16 capstan pulses. Page 3B-030 shows the logical connection of the capstan drive and reel drive systems.

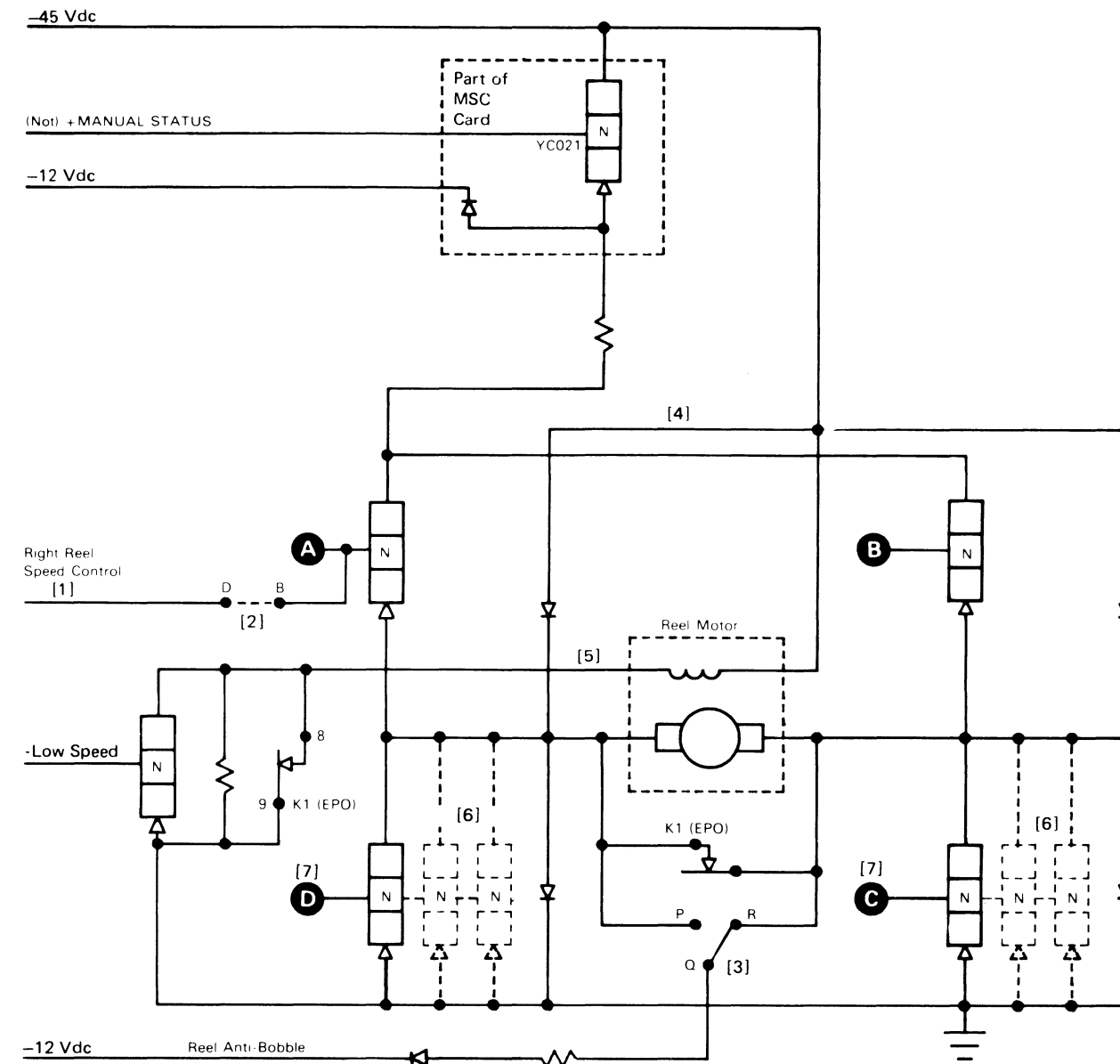

Switching for the various speeds is:

Motion	Drivers Active
Drive Forward	<b>A</b> and <b>C</b>
Drive Backward	<b>B</b> and <b>D</b>
Coast Forward	<b>C</b> only
Coast Backward	<b>D</b> only
Dynamic Brake	<b>C</b> and <b>D</b> *

\* **C** and **D** only on Models 4 and 6.

**C** Bkwd Brake and **D** Fwd Brake on Model 8.

### Notes:

- [1] Right reel turns at half speed on thread operation with Right Reel Speed Control grounded.
- [2] Jumper not connected on left reel board connector.
- [3] Reel boards are identical; connect the cable at Q-R on right reel board connector and Q-P on left reel board connector.
- [4] Voltage on this line (-12 Vdc or -45 Vdc) is determined by Manual Status/Not Manual Status.
- [5] Six volts nominal field voltage during high speed rewind.
- [6] Model 8 uses three power transistors in parallel for increased current carrying capacity.
- [7] Turning on drivers **C** and **D**, when Go Internal drops dynamically, brakes reel motion by shorting the armature, except on Model 8, which turns on **D** only (Fwd Brake) or **C** only (Bkwd Brake).

3803-2/3420

XC1200 Seq 1 of 2	2735789 Part Number	See EC History	845958 1 Sep 79				
----------------------	------------------------	-------------------	--------------------	--	--	--	--

© Copyright International Business Machines Corporation 1976, 1979

During normal rewind, the capstan control circuit controls capstan speed.

During high speed rewind, the capstan control circuit is disabled and the reel/capstan comparison circuits control capstan speed. These circuits compare the outputs of the right and left reel tachometers to the output of the 16 count generator.

High power drive is used during high speed rewind. Switching the capstan motor between high power drive and coast status controls capstan speed. To maintain optimum rewind speed while preventing tape from pulling out of, or bottoming in, the columns, additional circuits (two proportional drive and two proportional coast) are used to drive or coast the capstan for short periods of time. These circuits are controlled by singleshots.

**REEL TACHS**

During high speed rewind, the reel tachometers and reel/capstan comparison circuits control the reel motors and capstan speed.

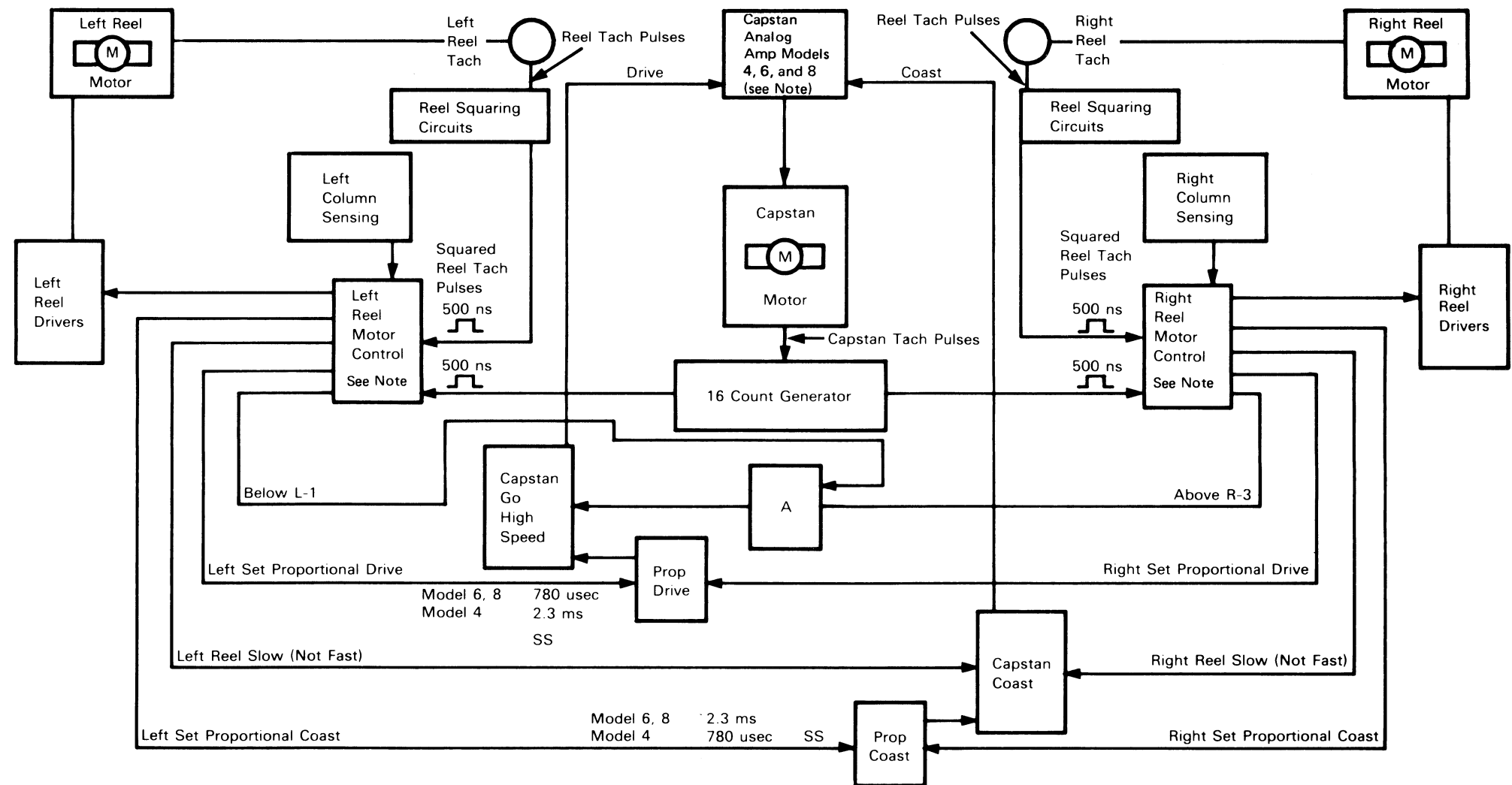

**Note:** The Reel Fast latch either causes the capstan to drive or lets it coast, depending on the position of tape in the columns. If the right and left circuits make different demands at the same time, coast overrides drive.

**Capstan Motor Status Relative to Position of Tape in Columns**

		Left Column		Right Column			
Loop Motion		Up	Down	Up	Down	Loop Motion	
Vacuum Column Ports	L1	C	PD	D	D	R1 R2 R3 R4	Vacuum Column Ports
	L2	PC	D	D	D		
	L3	D	D	D	PC		
	L4	D	D	PD	C		

**Abbreviations:**  
 C = Coast  
 D = Drive  
 PC = Prop Coast  
 PD = Prop Drive

3803-2/3420

XC1200	2735789	See EC	845958					
Seq 2 of 2	Part Number	History	1 Sep 79					

© Copyright International Business Machines Corporation 1976, 1979



# NO RESPONSE OR TAPE MOVES BACKWARD

The field tester activates Move and Forward Status to move tape forward. Sensing the end-of-tape (EOT) marker causes the field tester to drop the Move tag.

If tape goes backward until it is pulled off the end of the reel, reload the tape and unplug the capstan motor to make troubleshooting easier.

If tape unit will not load at mid-tape, unplug the capstan motor before attempting a normal load. Catch reels before tape bottoms and secure tape in place below L2 and above R2 vacuum ports.

### SET UP

Put tester in Fwd, St/Stp and in the failing mode (either Read or Write).

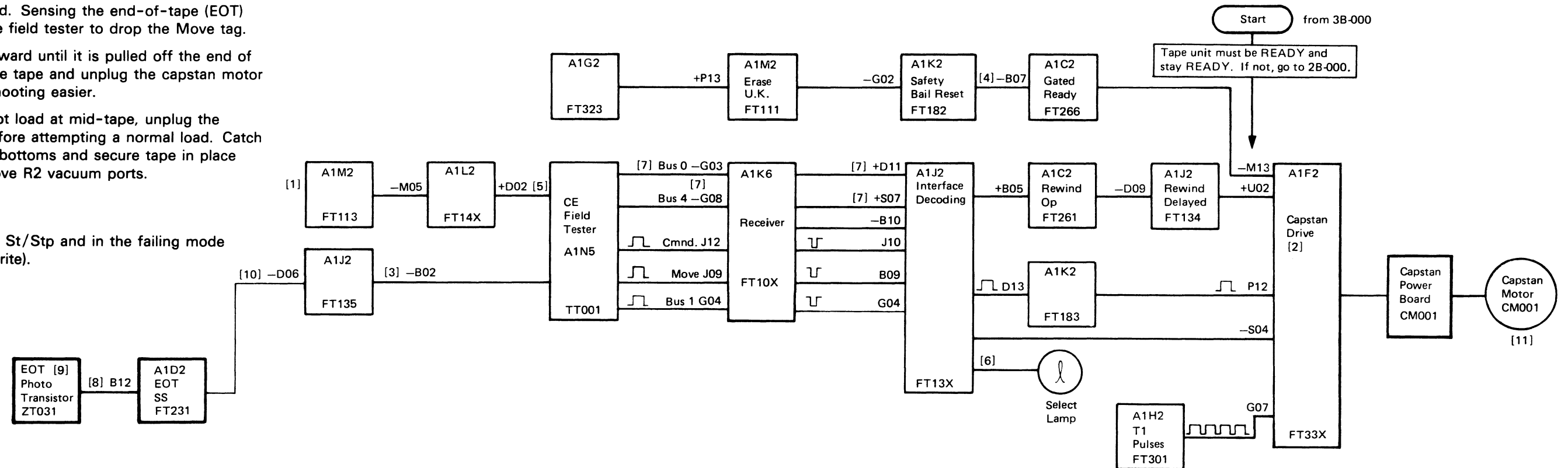

### Notes:

- + Indicates nominal MST-1 plus (up) level of  $-0.85$  Vdc; line should have solid up level or go to the up level.
- Indicates nominal MST-1 minus (down) level of  $-1.85$  Vdc; line should have solid down level or go to the down level.
- [1] If problem is not fixed, go to 1B-000.
- [2] Do not replace card T-A1H2. If all inputs are good, go to 6B-000 to determine the failing FRU.
- [3] Special voltage:  $+6$  Vdc to  $0$  Vdc.
- [4] Test with the START pushbutton pressed.
- [5] Special voltage: plus (up) level =  $+4.4$  Vdc; minus (down) level =  $0$  Vdc.
- [6] If the write head cable is not properly seated at the gate end, the drive will not activate Select.
- [7] This line will be pulsing for a write operation.
- [8] Typical voltage:  $+1.6$  Vdc dark and less than  $+1.5$  Vdc light.
- [9] Before replacing the phototransistor assembly, unplug the T-A1A3 cable. A voltage shift of approximately  $0.1$  Vdc at T-A1D2B12 indicates a good T-A1D2 card.
- [10] If level is incorrect, perform the BOT/EOT adjustments on 08-580.
- [11] Replace per Capstan Assembly Replacement. See 08-000.

3803-2/3420

XC1300	2735790	See EC	845958	847298				
Seq 1 of 2	Part Number	History	1 Sep 79	15 Aug 83				

# LEFT OR RIGHT VACUUM COLUMN—TAPE PULLS OUT, BOBBLES, BOTTOMS, OR EXHIBITS OTHER ABNORMAL MOTION SYMPTOMS

In order for the reel motor to keep up with the capstan motor, 48 volts is applied to both reel power boards by resetting Manual Status (ALD FT265) with Columns Loaded. The capstan should be running at a controlled speed (75 ips for Mod 4, 125 ips for Mod 6, and 200 ips for Mod 8).

- Press RESET, LOAD REWIND, and START again. The READY light should not come on.
- Put the field tester in Fwd and Go.

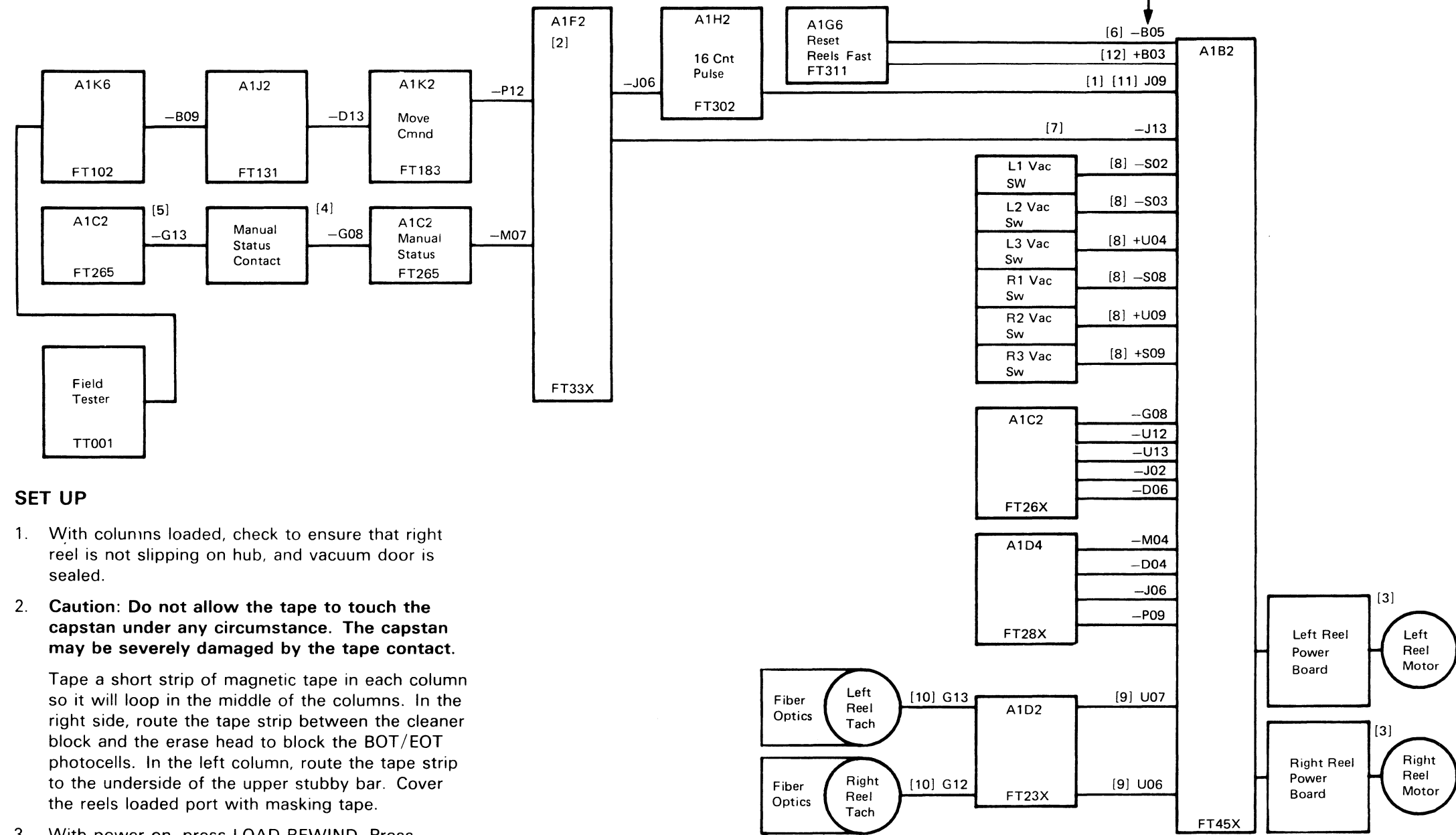

### SET UP

- With columns loaded, check to ensure that right reel is not slipping on hub, and vacuum door is sealed.
- Caution: Do not allow the tape to touch the capstan under any circumstance. The capstan may be severely damaged by the tape contact.**  
Tape a short strip of magnetic tape in each column so it will loop in the middle of the columns. In the right side, route the tape strip between the cleaner block and the erase head to block the BOT/EOT photocells. In the left column, route the tape strip to the underside of the upper stubby bar. Cover the reels loaded port with masking tape.
- With power on, press LOAD REWIND. Press RESET twice, then START. The READY light should come on because this is a mid-tape load.

3803-2/3420

XC1300 Seq 2 of 2	2735790 Part Number	See EC History	845958 1 Sep 79	847298 15 Aug 83				
----------------------	------------------------	-------------------	--------------------	---------------------	--	--	--	--

© Copyright International Business Machines Corporation 1976, 1979, 1983

### Notes:

- + Indicates nominal MST-1 plus (up) level of -0.85 Vdc; line should have solid up level or go to the up level.
  - Indicates nominal MST-1 minus (down) level of -1.85 Vdc; line should have solid down level or go to the down level.
- Negative pluses 520 ns ( $\pm 10\%$ ) in duration.  
Mod 4-0.98 milliseconds between pulses  
Mod 6-0.90 milliseconds between pulses  
Mod 8-0.75 milliseconds between pulses  
If period varies more than 5% from nominal, this line is bad.
  - Change T-A1F2. Go to 6B-000 to determine failing FRU if T-A1F2 is not the problem.
  - Reel power boards may be switched as a troubleshooting aid if the part numbers are the same. Check plugging.
  - Special voltage -0.5 Vdc to -2.5 Vdc.
  - Special voltage +12 Vdc to ground.
  - Press the RESET pushbutton. Level should pulse and then go plus. Press the LOAD REWIND and START pushbuttons before continuing.
  - If this line is bad, replace T-A1F2 and test tape unit before going to 6B-000.
  - Levels shown are for test set up. Manually pass tape across switch ports to determine operation. Level should be + above and - below the switch ports. Positioning the tape loop in the middle of the port may cause the vacuum switch to oscillate. Sync internal so you can use a scope to check the condition of the switch contacts. These are special voltage levels, -4 Vdc to ground.
  - Manually rotate reel tachs by pulling on the magnetic tape strips.
  - Special voltage: +1.7 Vdc to +0.6 Vdc.
  - After doing the Set Up, the capstan is moving backward at normal speed. If the tape unit failed only on forward motion, press the RESET and START pushbuttons to set the tape unit to forward status. The waveform at T-A1B2J09 should still be as described in Note 1.
  - Press the RESET pushbutton. Level should pulse and go minus. Press LOAD REWIND and START pushbuttons before continuing.

# TAPE FAILS TO GO BACKWARD

A Backward command from the field tester generates Backward Status, moving tape backward to load point.

The field tester sets Backward Status and activates the Move tag. These lines are decoded in the tape unit bus out circuits to develop the Go Backward operation.

## SET UP

1. Move tape forward away from load point. Leave tape unit in READY condition.
2. Set field tester to Bkwd Read, St/Stp.

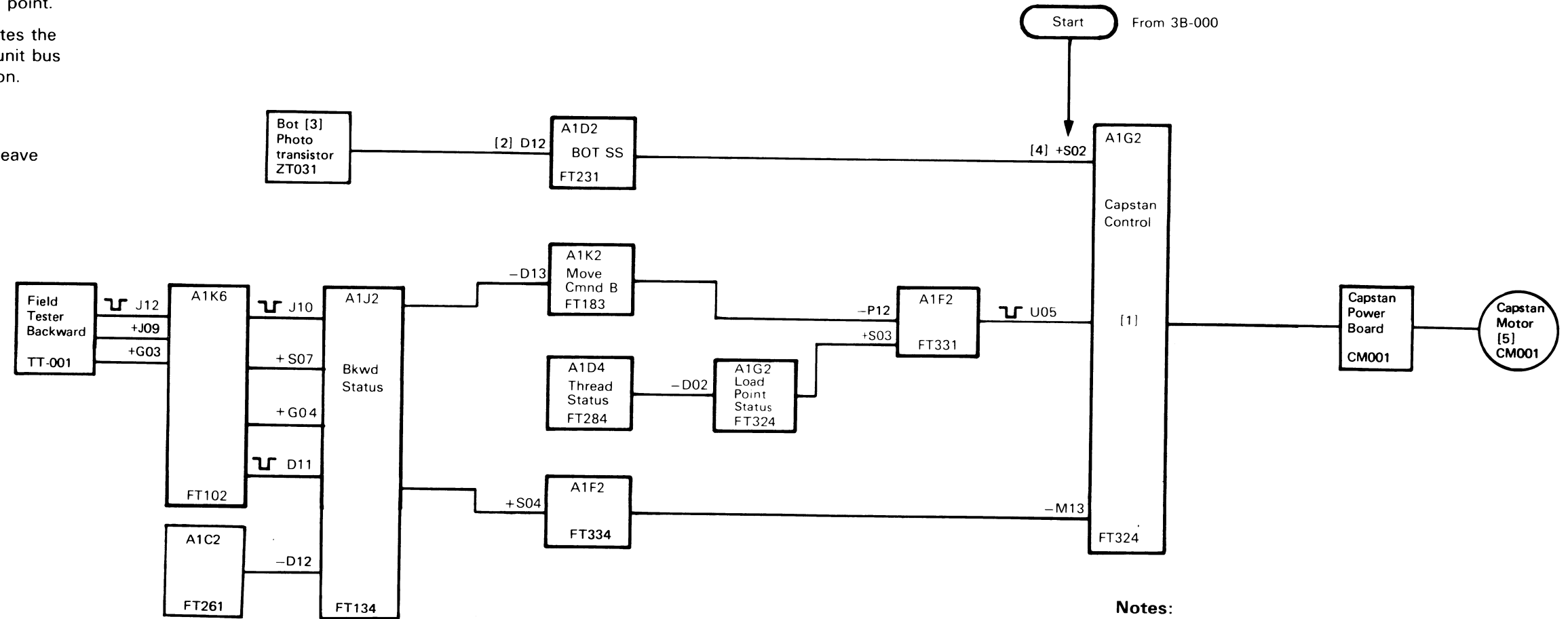

### Notes:

- + Indicates nominal MST-1 plus (up) level of  $-0.85$  Vdc; line should have solid up level or go to the up level.
  - Indicates nominal MST-1 minus (down) level of  $-1.85$  Vdc; line should have solid down level or go to the down level.
- [1] If this output is good, go to 6B-000 to diagnose the failing FRU.
  - [2] Special voltage:  $+1$  Vdc to  $+1.6$  Vdc.
  - [3] Before replacing the phototransistor assembly, unplug the T-A1A3 cable. A voltage shift (approximately  $0.1$  Vdc) at T-A1D2D12 indicates a good T-A1D2 card.
  - [4] If the level is incorrect, perform BOT/EOT adjustment (see 08-580) before checking T-A1D2 input.
  - [5] Replace per capstan assembly removal and replacement procedures. See 08-000.

3803-2/3420

XC1400	2735791	See EC History	845958				
Seq 1 of 2	Part Number		1 Sep 79				

# TAPE DOES NOT STOP OR TAPE RUNAWAY (FORWARD OR BACKWARD)

Setting the field tester to Stop prevents the tape moving forward or backward by deactivating the Move tag.

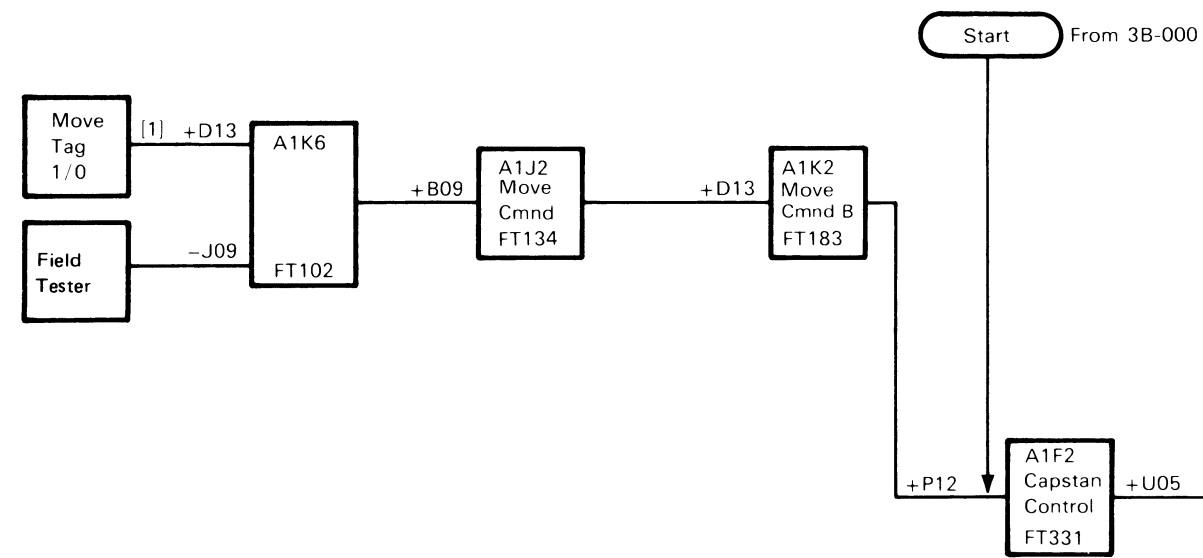

**Notes:**

- + Indicates nominal MST-1 plus (up) level of -0.85 Vdc; line should have solid up level or go to the up level.
- Indicates nominal MST-1 minus (down) level of -1.85 Vdc; line should have solid down level or go to the down level.
- [1] Plus (up) level is +4.4 Vdc and minus (down) level is -0 Vdc.

3803-2/3420

XC1400	2735791	See EC	845958						
Seq 2 of 2	Part Number	History	1 Sep 79						

© Copyright International Business Machines Corporation 1976, 1979



# TAPE UNWINDS OFF RIGHT REEL

When the end-of-tape EOT marker is sensed, Tape Indicate is set (ALD FT135). Tape Indicate generates a status Bus In Bit 2 which causes the field tester to deactivate the Move tag. The tester deactivates the Move tag and stops the tape with the TI indicator on. Press RESET and Load Rewind on the tester, and tape begins to rewind. When the EOT marker is sensed in a backward direction, the tester will reset the Tape Indicate latch and turn off the indicator.

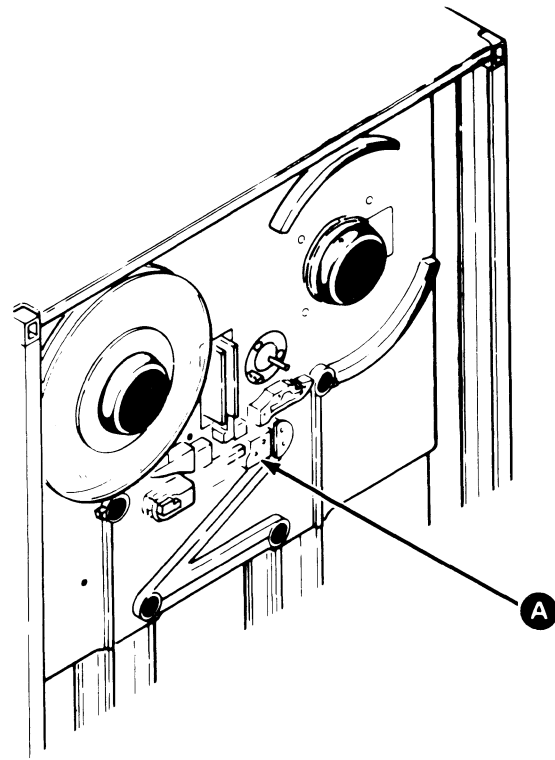
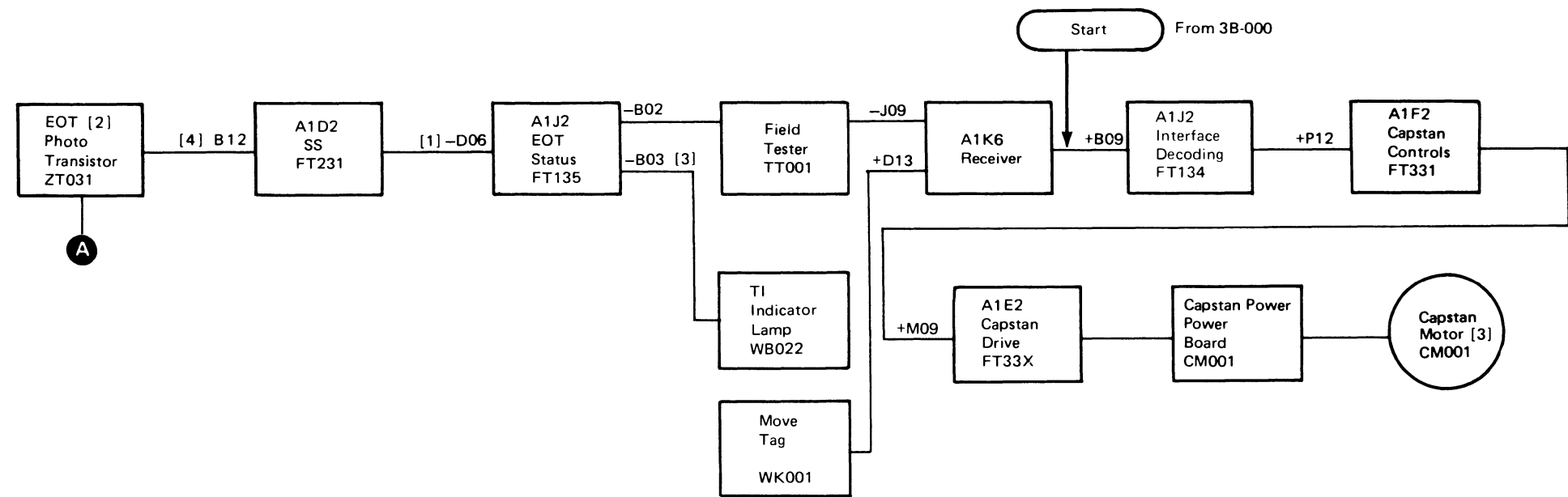

**Notes:**

- + Indicates nominal MST-1 plus (up) level of -0.85 Vdc; line should have solid up level or go to the up level.
- Indicates nominal MST-1 minus (down) level of -1.85 Vdc; line should have solid down level or go to the down level.
- [1] Signal is present only as EOT marker passes over BOT/EOT sensing assembly. If this line level is incorrect, perform the BOT/EOT adjustments (See 08-580) before checking the T-A1D2 card.
- [2] Before replacing the phototransistor assembly, unplug the T-A1A3 cable. A voltage shift of approximately 0.1 Vdc indicates a good T-A1D2 card.
- [3] Plus (up) level is +12 Vdc and minus (down) level is 0 Vdc.
- [4] Special voltage levels: +1 Vdc to 1.6 Vdc.

3803-2/3420

XC1500	2735792	See EC	845958						
Seq 1 of 2	Part Number	History	1 Sep 79						

# TAPE PULLS OUT, DUMPS, OR HAS WIDE EXCURSIONS IN LEFT COLUMN DURING HIGH SPEED REWIND

When high speed rewind is initiated, the reel tachometers must sense that both reels are turning at normal operating speed before high speed rewinding begins. Tape motion starts with the capstan under normal control and the reel motors in high speed rewind status. After tape speed at both reels exceeds tape speed at the capstan, High Speed Field latch is set. This holds the Polarity Hold Drive (PHD) register reset, and capstan speed is controlled by Rewind Current and Step Down Current. High Speed Field (ALD FT45X) reduces the reel-motor field voltage to 6 volts, which allows the reel motor to turn faster. The capstan accelerates from 600 to 800 ips in less time than the reels, due to the reels' greater inertia and causes the tape to rise above the L1 or drop below R3, vacuum switches which activates Capstan Cutout (ALD FT45X) to slow the capstan. When the tape reels reach their maximum speed, the capstan speed stabilizes between 600 and 800 ips.

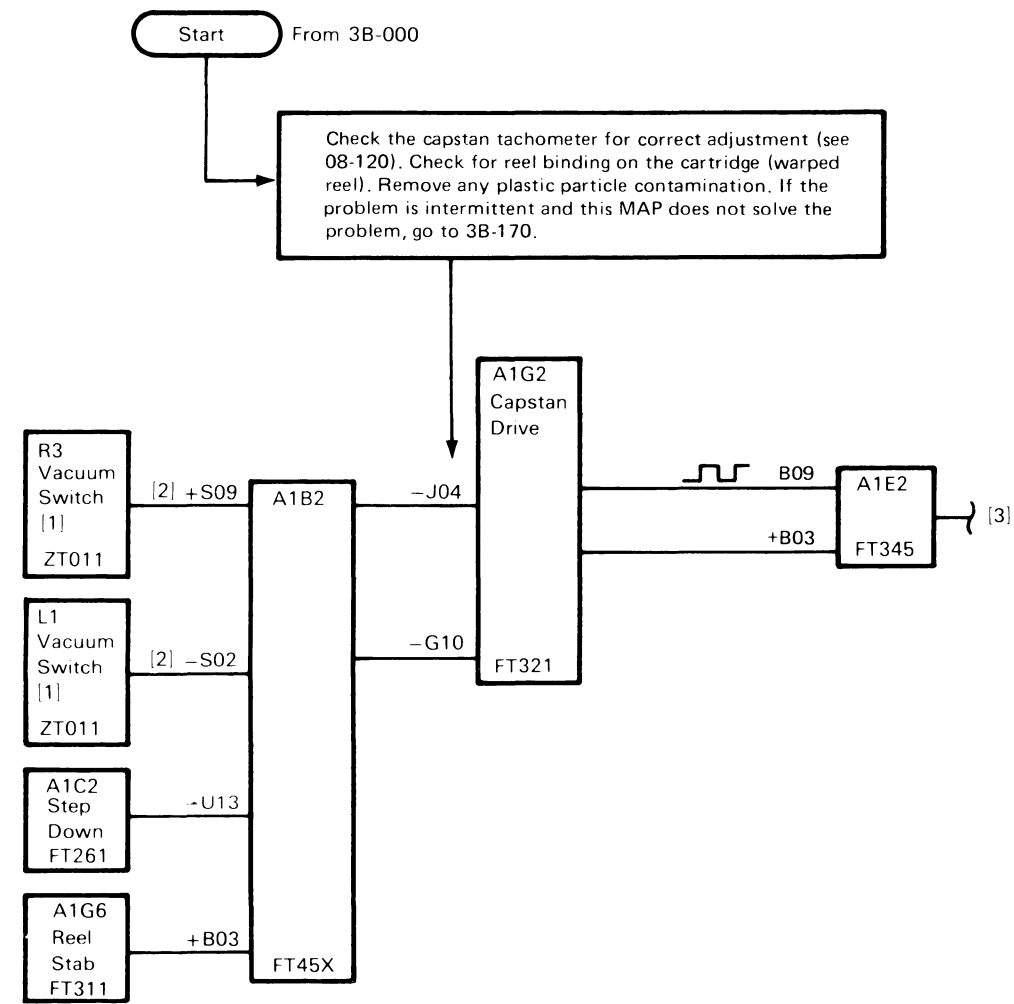

**Notes:**

- + Indicates nominal MST-1 plus (up) level of -0.85 Vdc; line should have solid up level or go to the up level.
- Indicates nominal MST-1 minus (down) level of -1.85 Vdc; line should have solid down level or go to the down level.
- [1] Check per Vacuum Column Switch Test. See 08-800.
- [2] When vacuum is present, level is plus (0 Vdc) with tape above the vacuum switch, and minus (-4 Vdc) with the tape below the vacuum switch.
- [3] If input to T-A1E2 is good, go to 3B-170 to locate failing FRU.

3803-2/3420

XC1500 Seq 2 of 2	2735792 Part Number	See EC History	845958 1 Sep 79					
----------------------	------------------------	-------------------	--------------------	--	--	--	--	--

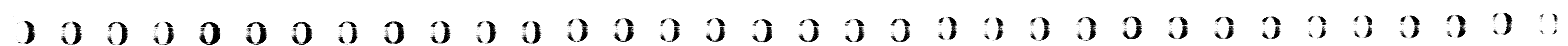

# TAPE DOES NOT ENTER OR DOES NOT STAY IN HIGH SPEED REWIND STATUS

Tape should rewind at high speed until the radius sense photocell detects light from the left reel light source. Reel Revolution pulses (ALD FT231) or loss of a quarter tach pulse develop a High Speed Rewind Reset pulse which resets the High Speed Rewind Status latch (ALD FT261). To use the information on this page, you should have enough tape on the left reel to cover the radius sense detector.

Reel tachometers must indicate that both reels are turning at normal operating speed before high speed rewind begins. Clean reel tachometers before starting.

If you are unable to diagnose intermittent failures using this page, change the R4 and L4 vacuum switches. If you still have intermittent failures, change L1 and R3 vacuum switches.

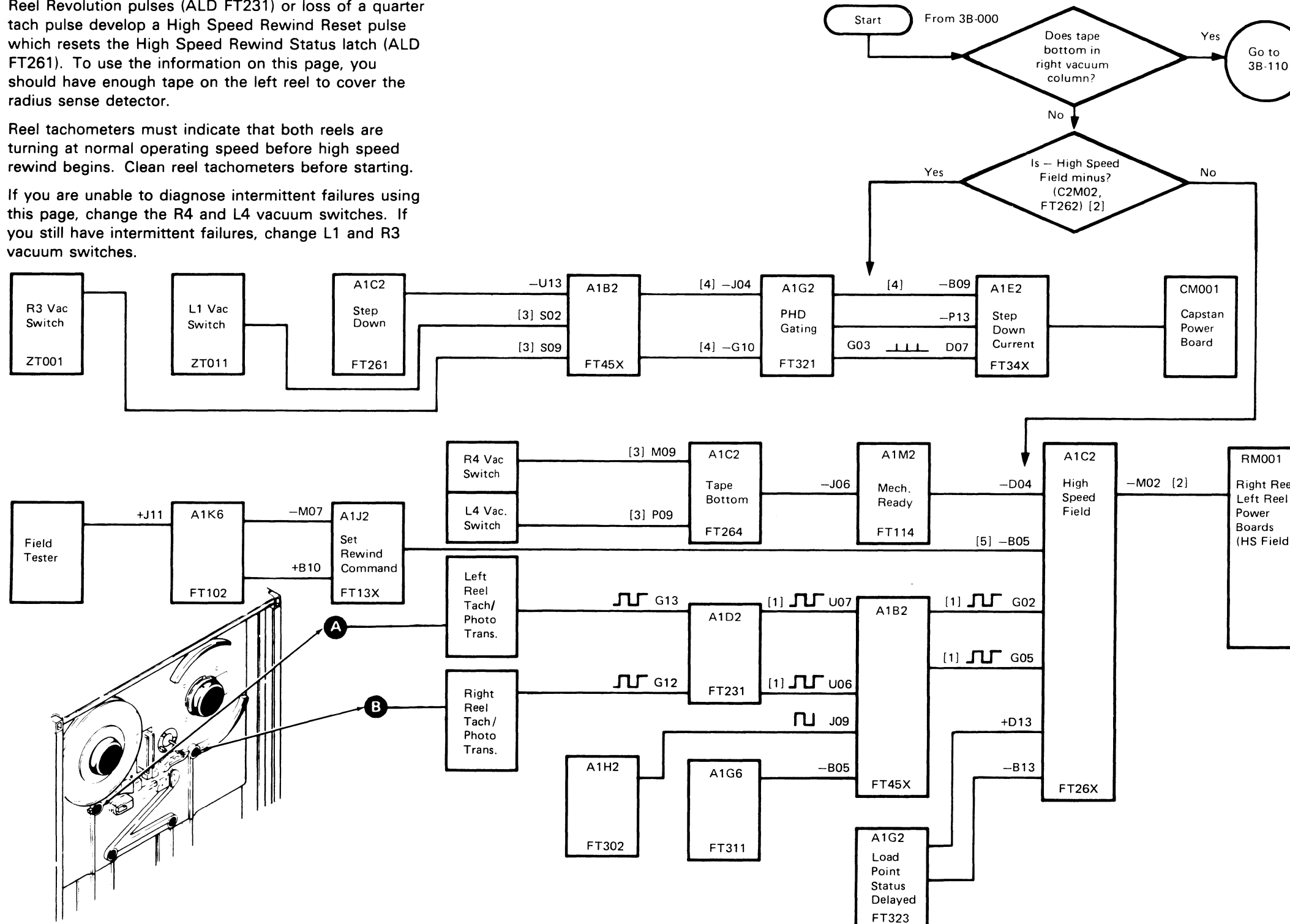

**Notes:**

- + Indicates nominal MST-1 plus (up) level of -0.85 Vdc; line should have solid up level or go to the up level.
- Indicates nominal MST-1 minus (down) level of -1.85 Vdc; line should have solid down level or go to the down level.
- [1] Compare both right and left reel tach outputs during high speed rewind. Both should have plus pulses of approximately the same duration and frequency. If a reel tach has no output, suspect the photocell or fiber optics. If either reel tach output has longer positive pulses or lower frequency, suspect a binding or slipping tach.
- [2] Special voltage levels: +12 Vdc to 0 Vdc.
- [3] With vacuum present, level is up (plus) with tape above the vacuum switch and down (minus) with tape below vacuum switch. Special voltage levels: 0 Vdc to -4 Vdc.
- [4] Random plus pulses are allowed.
- [5] If backward motion starts, ignore the state of this line.

3803-2/3420

XC1600	2735793	See EC History	845958	847298				
Seq 1 of 2	Part Number		1 Sep 79	15 Aug 83				

© Copyright International Business Machines Corporation 1976, 1979, 1983

# TAPE STAYS IN HIGH SPEED REWIND STATUS TO LOAD POINT OR REWINDS OFF LEFT REEL

When the decreasing tape radius exposes the reflective marker in the left reel, the Radius Sense photocell is triggered to indicate the end of the high speed rewind area. The Radius Sense photocell generates a HS Reset pulse which resets the HS Rewind Status latch and activates Step Down (ALD FT261) to initiate low speed rewind. The reel motor field voltages are switched to 48 volts for the low speed rewind operation.

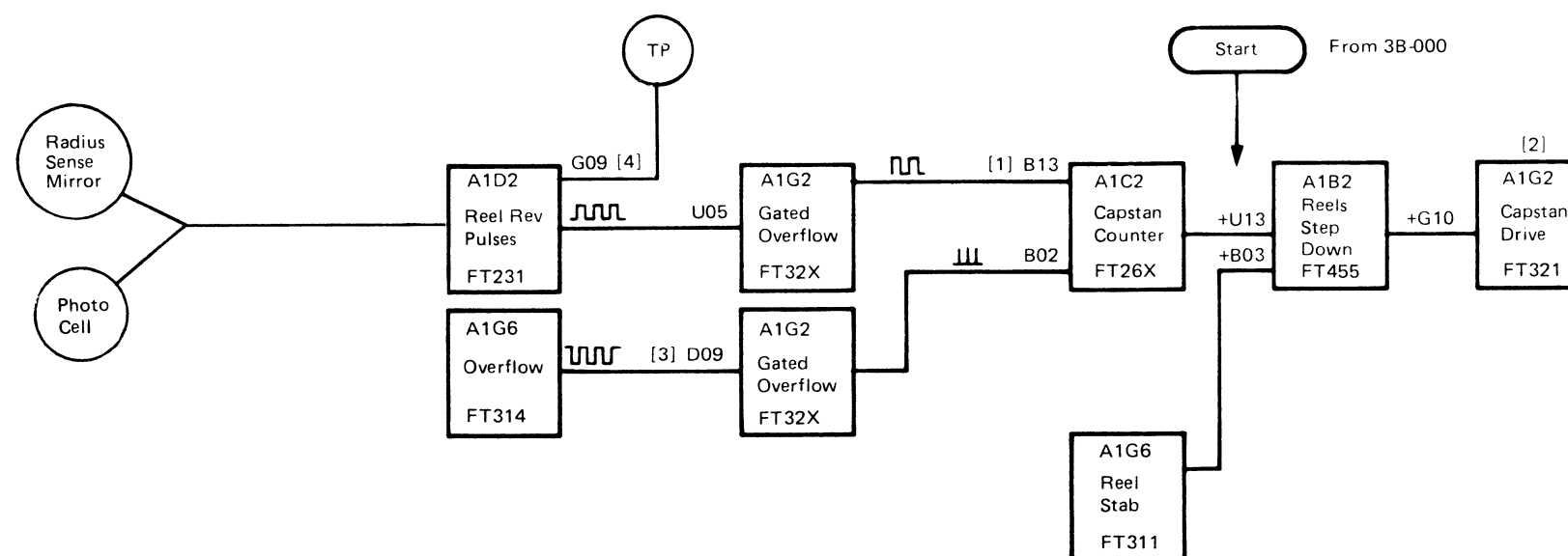

**Notes:**

- + Indicates nominal MST-1 plus (up) level of -0.85 Vdc; line should have solid up level or go to the up level.
- Indicates nominal MST-1 minus (down) level of -1.85 Vdc; line should have solid down level or go to the down level.
- [1] High Speed reset pulse from radius sense in left reel.
- [2] If input to T-A1G2 card is good, go to page 6B-000 to continue diagnosis; do not replace G2.
- [3] Set scope to 0.2 ms/div. This line has several minus pulses as load point is reached.
- [4] If the radius sense does not pulse in the low speed area, clean the ends of the fiber optic bundle with a damp cloth (see 08-610 for removal). Also, apply a felt pad to handle and lightly dampen with tape cleaning fluid. Hold pad to the inside front of left reel and spin by hand. This will clean the reflective strips located on the inside front of the left reel flange.

3803-2/3420

XC1600	2735793	See EC History	845958	847298				
Seq 2 of 2	Part Number		1 Sep 79	15 Aug 83				

© Copyright International Business Machines Corporation 1976, 1979, 1983



**UNLOAD FAILURE SYMPTOMS**

**Note:** This MAP assumes that the tape will load correctly.

**UNLOAD OPERATION WITH CARTRIDGE**

An unload operation is started by pressing the RESET and UNLOAD REWIND pushbuttons. If the tape is not at the beginning-of-tape marker (BOT), it is rewound to BOT before it is unloaded.

Pressing UNLOAD REWIND switch activates Manual Status, Rewind Unload Status, and Unload Ad Op. Unload Op and Manual Status cause the right reel to turn counterclockwise pulling the tape out of the columns. When the tape is pulled out of the right column, pneumatics drop and the transfer valve solenoid is energized. Pneumatics turn on again, but the transfer valve shuts off air and vacuum to the air bearings and columns. At the same time, the right reel stops and the left reel turns clockwise. The left reel pulls the remaining tape out of the columns until the Reels Loaded switch is transferred.

When the Reels Loaded switch is transferred, pneumatics drop and both reels turn counterclockwise until all the tape is on the right reel. Columns Unloaded is activated when vacuum sensing switches R4 and L4 transfer. Not Tape Present is activated when the end of the tape leader passes the BOT/EOT phototransistors. Unload Complete is activated by Columns Unloaded and Not Tape Present.

Unload Complete causes the cartridge to close.

After an unload operation, the physical end of the tape should stop within the cartridge at a position of approximately 4 o'clock. If the physical end of the tape stops below 4 o'clock, ensure A1D2J09 is grounded. If the end of the tape stops above 4 o'clock, ensure A1D2J09 is not grounded. If necessary, delete the board land A1D2J08 to A1D2J09 located on the card side of the board.

**UNLOAD OPERATION WITHOUT CARTRIDGE**

The unload operation without a cartridge is the same as with a cartridge except that the cartridge motor does not operate.

From 00-040, Start 1		
<b>Probable Causes:</b>		
<ul style="list-style-type: none"> <li>• BOT/EOT mirror is dirty.</li> <li>• BOT/EOT requires adjustment.</li> <li>• Transfer valve malfunction. (Do leakage test on 08-400)</li> <li>• T-A1C2, T-A1D4 defective.</li> </ul>		
<b>Always start with Seq 1 and follow the procedure in sequence unless directed otherwise. Remember to END all problems or maintenance calls by going to MAP 00-030.</b>		
Seq	Condition/Instruction	Action
1A	Does the tape unit unload using the UNLOAD REWIND pushbutton, but does not unload from the tape control unit or the field tester?	Replace: T-A1K6 T-A1J2  If not fixed, go to ALD FT134 (+Set Unload Rewind Command) and continue troubleshooting.
1B	Be sure the tape unit is loaded, at load point, and ready.	
2	Does the Ready indicator stay on when RESET is pressed?	Go to 4B-100.
3	Does the right reel turn ccw when UNLOAD REWIND is pressed?	Go to Seq 5.
4	If not:	Go to 4B-110.
5	Does the tape come out of both columns properly?	Go to Seq 7.
6	If not:	Go to 4B-120.
7	Does the tape wind completely onto right reel?	Go to Seq 9.
8	If not:	Go to 4B-130.
9	Do both reels stop?	Go to Seq 11.
10	If not:	Clean EOT/BOT mirror. Check BOT/EOT adjustments. See 08-000. If problem persists, go to 4B-130.
11	Does the pneumatic motor turn off?	Go to Seq 13.
12	If not:	Go to 4B-160.
13	Is a cartridge in use?	Go to Seq 16.
14	Does the power window go down?	Recheck symptoms.
15	If not:	Go to 4B-140.
16	Does cartridge close?	Go to Seq 18.
17	If not:	Go to 4B-150.
18	Did the cartridge motor make an audible noise when the cartridge closed?	Replace the cartridge motor.
19	If not:	Go to Seq 14.

3803-2/3420

XC1700	2735794	See EC	845958	846927	847298			
Seq 1 of 2	Part Number	History	1 Sep 79	20 Jun 80	15 Aug 83			

# READY LAMP DOES NOT TURN OFF

The RESET pushbutton resets Ready Status, which turns off the READY indicator (ALD FT26X).

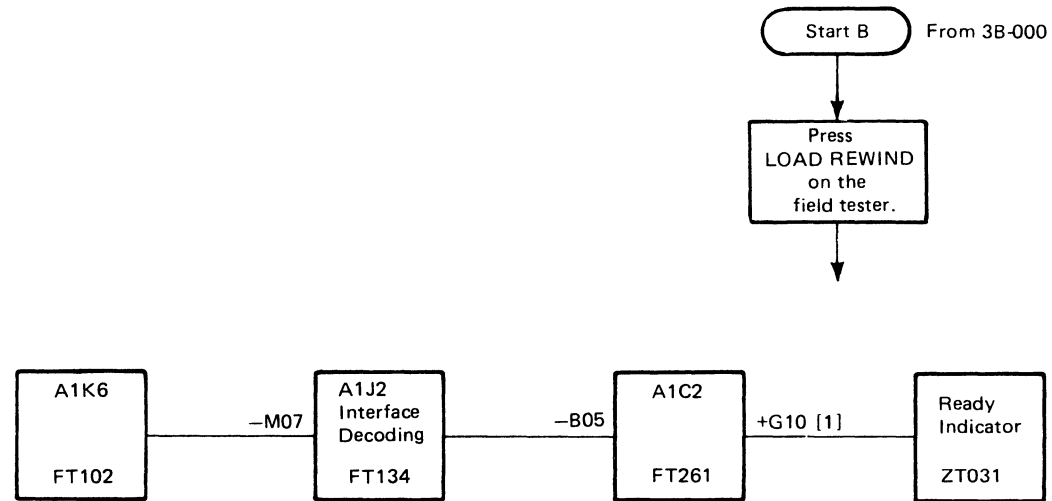
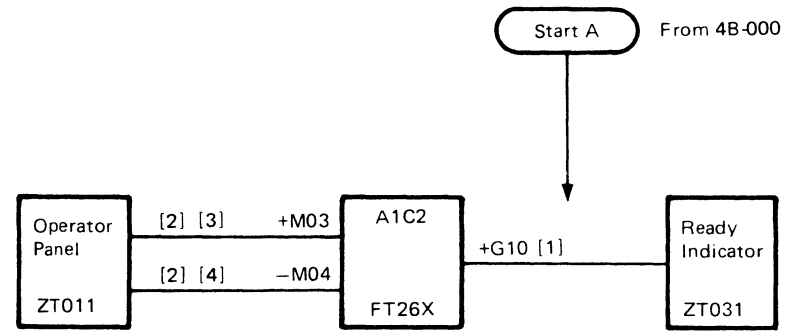

**Notes:**

- + Indicates nominal MST-1 plus (up) level of  $-0.85$  Vdc; line should have solid up level or go to the up level
- Indicates nominal MST-1 minus (down) level of  $-1.85$  Vdc; line should have solid down level or go to the down level.
- [1] Plus (up) level is 12 Vdc and minus (down) level is 0 Vdc.
- [2] Plus (up) level is 0 Vdc and minus (down) level is  $-4$  Vdc.
- [3] Up level is present with the RESET pushbutton pressed.
- [4] Level is present unless START pushbutton is pressed.

3803-2/3420

XC1700	2735794	See EC History	845958	846927	847298			
Seq 2 of 2	Part Number		1 Sep 79	20 Jun 80	15 Aug 83			

© Copyright International Business Machines Corporation 1976, 1979, 1980, 1983



# TAPE DOES NOT PULL OUT OF COLUMNS PROPERLY DURING UNLOAD REWIND

**Caution: If the right reel does not stop, tape damage may result.**

Unload starts the right reel turning counterclockwise, pulling tape out of the right column. As vacuum switch R1 transfers, vacuum drops as pneumatics drop, L4 and R4 vacuum switches transfer. When L4 and R4 transfer, this signals Columns Unloaded status which:

1. Activates the transfer valve.
2. Activates the pneumatics motor.
3. Stops the right reel motor see CAUTION above).
4. Activates the left reel motor in a clockwise direction (ALD FT283) taking tape out of the left column.

When Reels Loaded is sensed, the pneumatics motor is dropped and both reels turn counterclockwise until all the tape is on the right reel.

**Notes:**

- + Indicates nominal MST-1 plus (up) level of -0.85 Vdc; line should have solid up level or go to the up level.
  - Indicates nominal MST-1 minus (down) level of -1.85 Vdc; line should have solid down level or go to the down level.
- [1] Plus level is 0 Vdc and minus level is -4 Vdc. With vacuum present and tape above the port, the level will be plus.
  - [2] Plus level is +12 Vdc and minus level is 0 Vdc.
  - [3] If the right reel does not stop, tape damage may occur.
  - [4] If T-A1B2 and the reel board have been replaced, and the trouble still exists, refer to OPER section for theory.
  - [5] See 08-400 for transfer valve leakage test.
  - [6] Line is minus until tape is out of the right column. Then the line goes plus until tape is out of the left column.

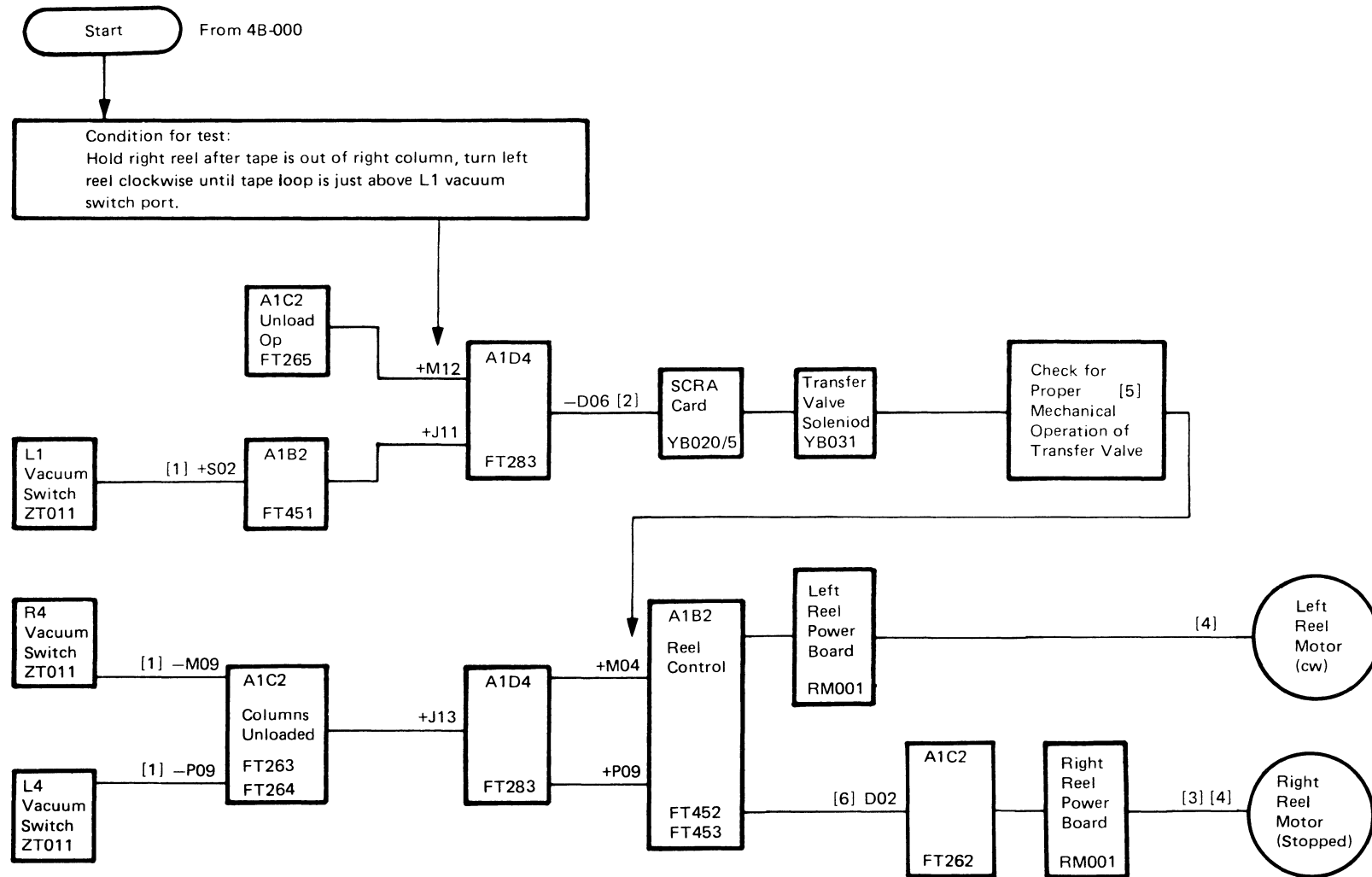

3803-2/3420								
XC1800	2735795	See EC History	845958	846927	847298			
Seq 2 of 2	Part Number		1 Sep 79	20 Jun 80	15 Aug 83			

# TAPE DOES NOT WIND COMPLETELY ONTO RIGHT REEL OR REELS DO NOT STOP

As tape is removed from the columns, tape tightens over the Reels Loaded switch, located in the left threading channel. Then both reels turn counterclockwise, taking up tape until the end of the tape passes the BOT/EOT phototransistors. This deactivates Tape Present (ALD FT281). Delay in the Tape Present circuits causes the right reel to continue turning until the tape is completely restored onto the right reel.

- [1] If reels do not stop, use Start A.
- [2] If tape does not wind completely onto right reel, use Start B.

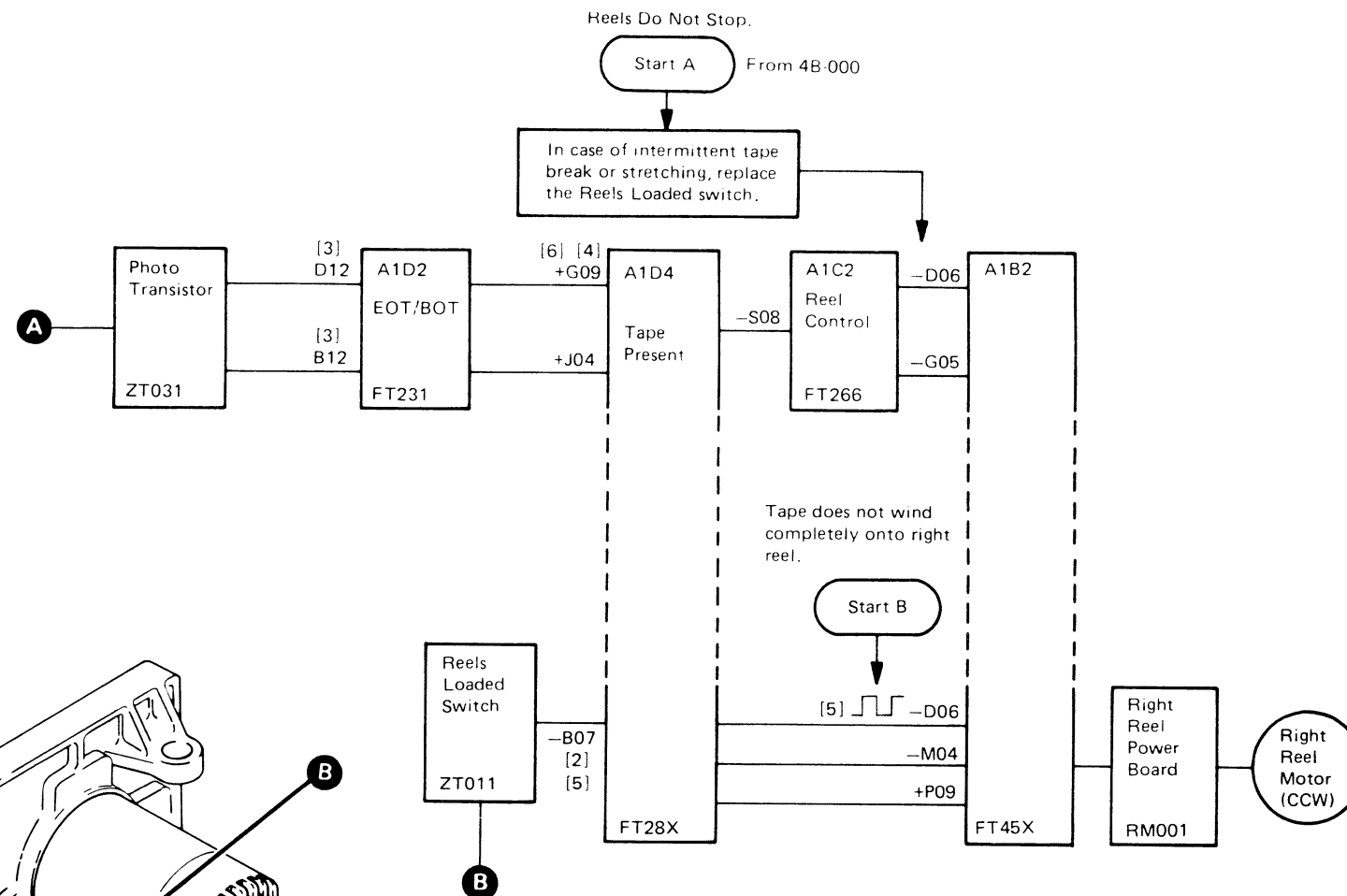
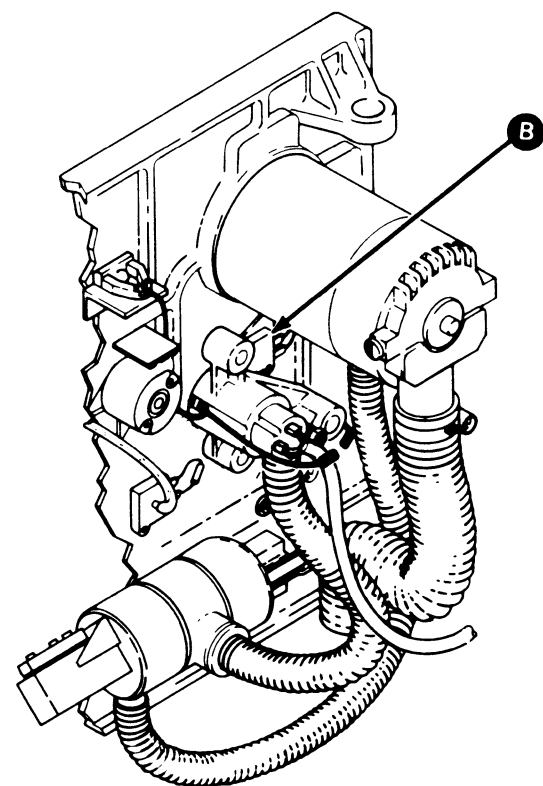
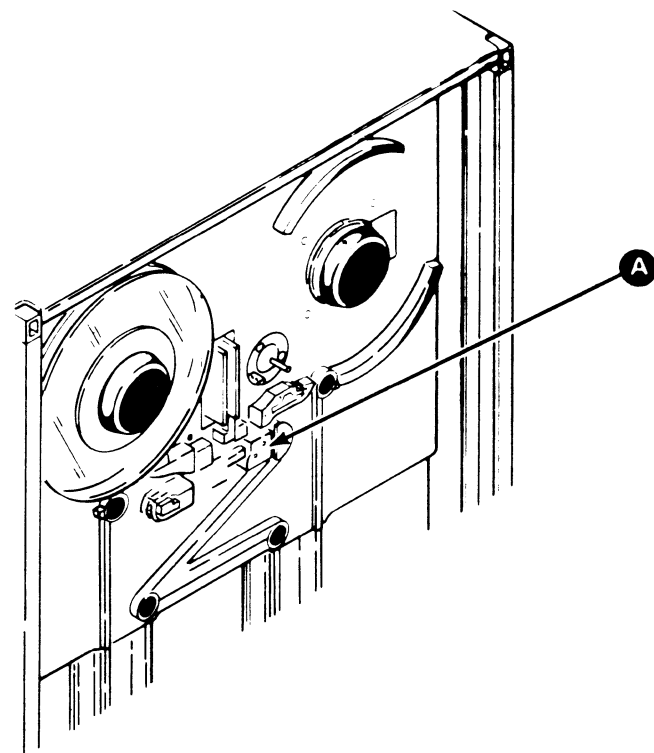

**Notes:**

- + Indicates nominal MST-1 plus (up) level of -0.85 Vdc; line should have solid up level or go to the up level.
- Indicates nominal MST-1 minus (down) level of -1.85 Vdc; line should have solid down level or go to the down level.
- [2] Plus (up) level is 0 Vdc and minus (down) level is -4 Vdc.
- [3] Typical voltage levels: +1.6 Vdc dark to less than +1.5 Vdc light.
- [4] Special voltage levels: 0 Vdc to -4 Vdc.
- [5] Positive when tape is taut across left threading channel.
- [6] If this level is incorrect, perform the BOT/EOT adjustment before the T-A1D2 card inputs (see 08-580).

3803-2/3420

XC1900 Seq 1 of 2	2735796 Part Number	See EC History	845958 1 Sep 79	846927 20 Jun 80	847298 15 Aug 83			
----------------------	------------------------	-------------------	--------------------	---------------------	---------------------	--	--	--

© Copyright International Business Machines Corporation 1976, 1979, 1980, 1983

# POWER WINDOW DOES NOT GO DOWN

The power window provides access to the right reel for loading and unloading. The window is raised only when LOAD REWIND or RESET is pressed. It is lowered when an unload operation has been completed.

The window is raised by a motor-driven rack and gear assembly. It is counterbalanced by springs. To maintain window alignment, an idler roller on each side of the window rolls in guides.

The drop of Tape Present turns on Unload Complete (ALD FT266), which resets Unload Op (ALD FT265). This signals the pneumatic motor to turn off. When the air pressure in the right reel hub drops below 40 inches (1016 mm) of water, the window will go down.

The motor is controlled by a relay, the Window-Up switch and the Window-Down switch. Motor direction is determined by the direction of motor current. When LOAD REWIND or RESET is pressed, the relay is picked to drive the motor. The motor continues to drive until the Window-Up switch opens, removing voltage from the motor. The relay remains picked while the window is up. The window is lowered by dropping the relay, which reverses the direction of motor current and bypasses the Window-Up switch. Voltage is removed from the motor when the Window-Down switch opens.

The door contains a safety bail. The safety bail is a cable, enclosed in a hollow gasket, stretched across the top of the window. Any object applying sufficient pressure to the safety bail transfers the Safety Bail switch, deactivating the relay. The window drive motor reverses and lowers the window.

### SET UP:

1. Press the UNLOAD REWIND pushbutton. If the window fails to go down, begin at Start A.
2. If the operation is initiated by a programmed rewind/unload, or a rewind/unload from the 3803 and the window fails to go down, begin at Start B.

### Notes:

- + Indicates nominal MST-1 plus (up) level of  $-0.85$  Vdc; line should have solid up level or go to the up level.
- Indicates nominal MST-1 minus (down) level of  $-1.85$  Vdc; line should have solid down level or go to the down level.
- [1] Plus level is +12 Vdc and minus level is 0 Vdc.
- [2] Special voltage:  $-0.9$  Vdc to +6 Vdc. Minus if switch is activated.
- [3] Plus level is +0V and minus level is  $-4$  Vdc. Level is minus when pneumatics are off.
- [4] Verify that window motor retaining screws are tight.
- [5] Line level should be plus with UNLOAD REWIND pushbutton pressed.
- [6] Special voltage: 0 Vdc to  $-4$  Vdc.

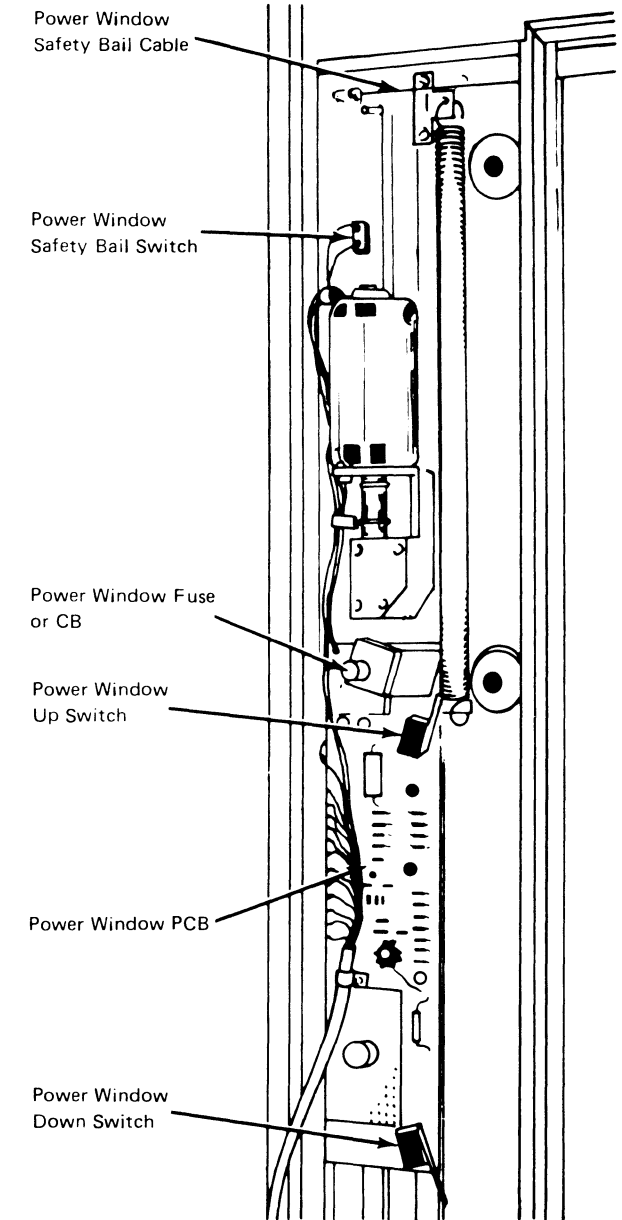
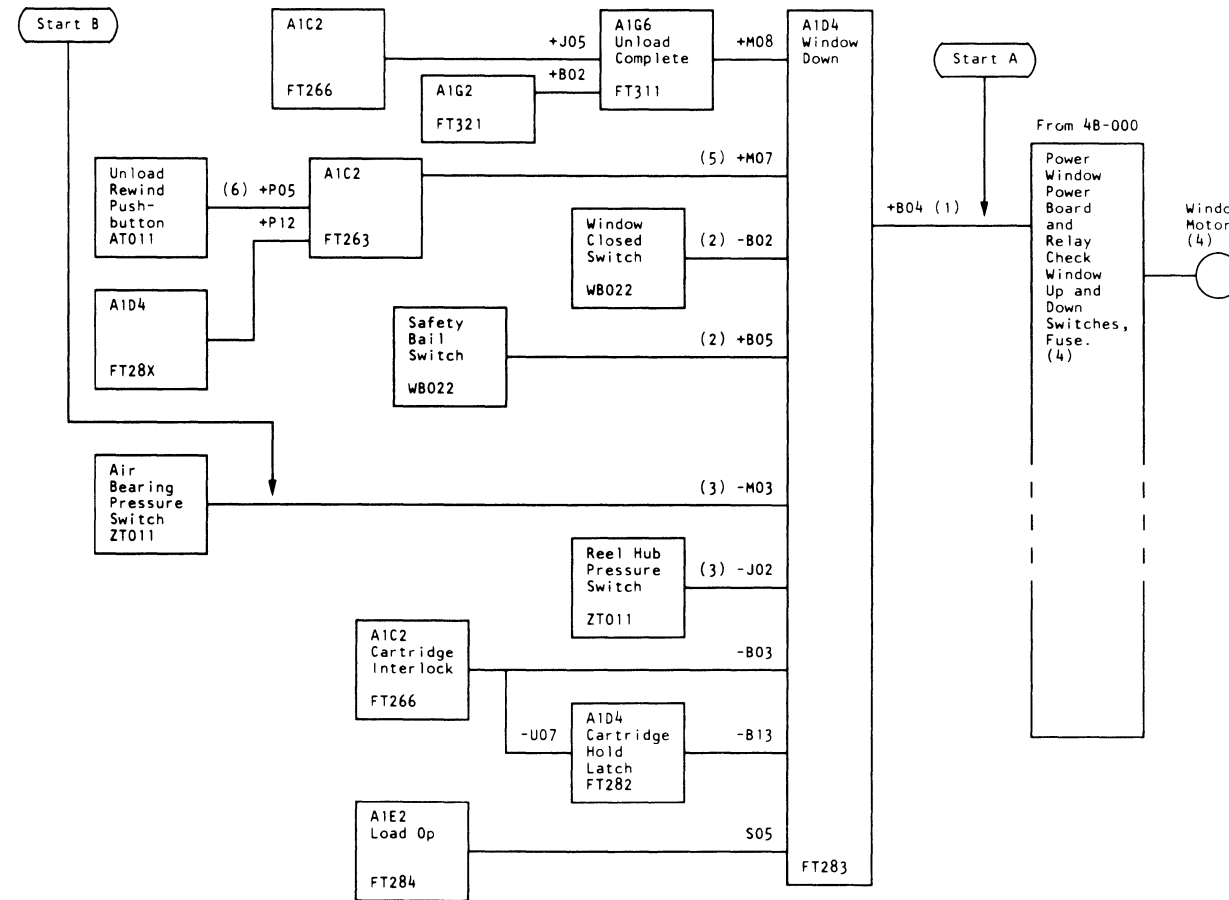

3803-2/3420

XC1900 Seq 2 of 2	2735796 Part Number	See EC History	845958 1 Sep 79	846927 20 Jun 80	847298 15 Aug 83		
----------------------	------------------------	-------------------	--------------------	---------------------	---------------------	--	--

© Copyright International Business Machines Corporation 1976, 1979, 1980, 1983

# CARTRIDGE DOES NOT CLOSE

Deactivating Tape Present turns on Unload Complete (ALD FT28X) and starts the cartridge motor, which closes the cartridge. When the Cartridge Closed switch transfers, the cartridge motor stops.

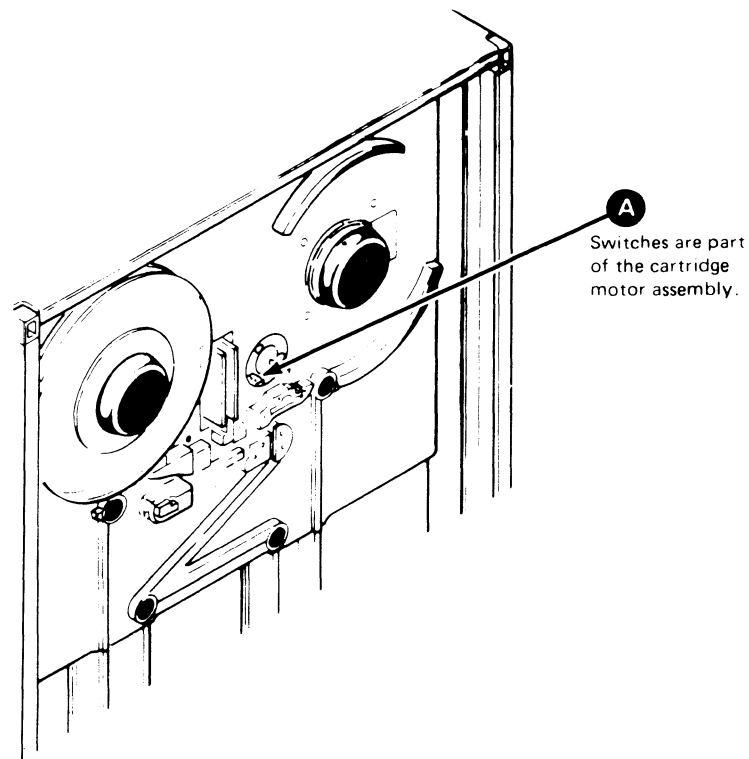
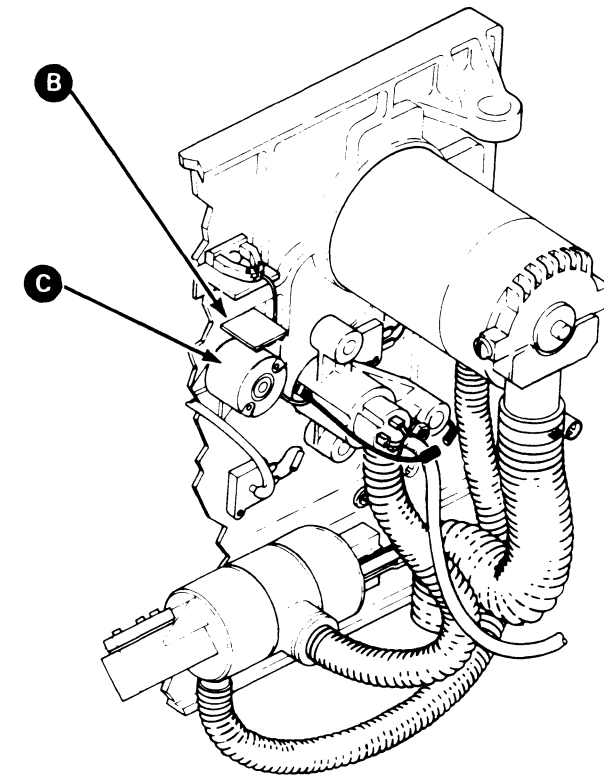
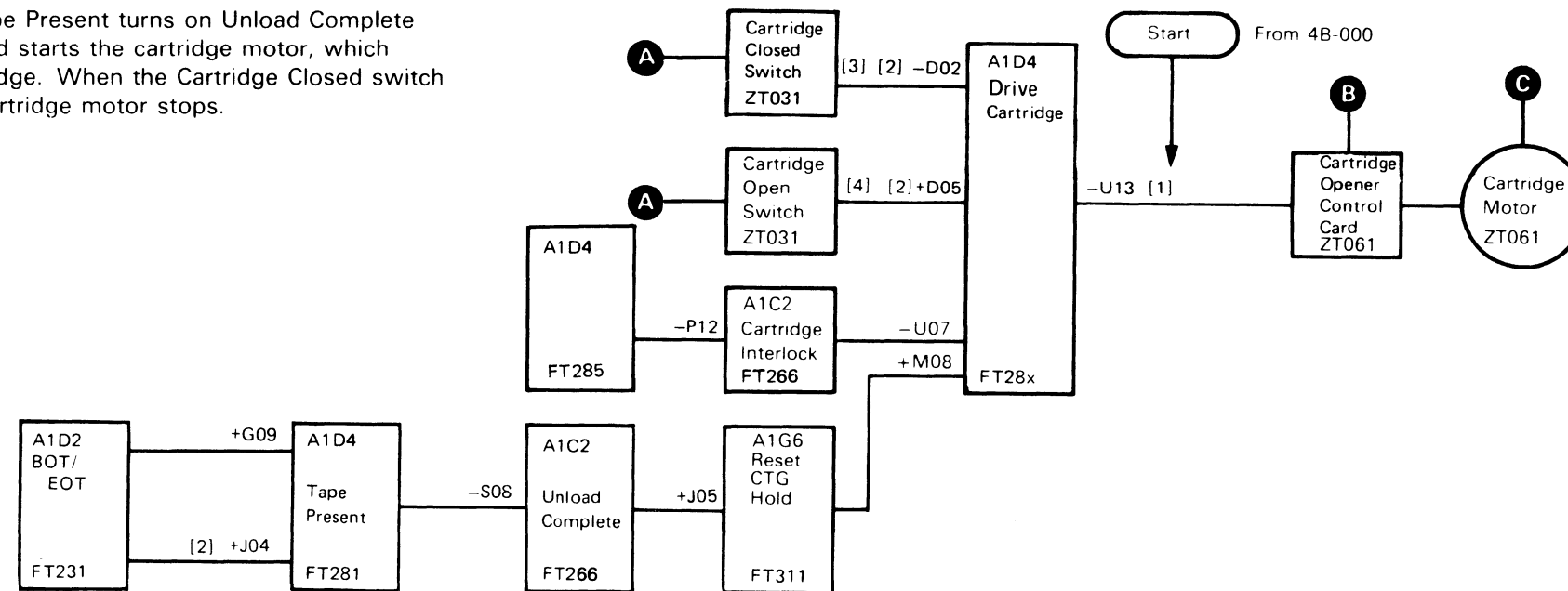

**Notes:**

- + Indicates nominal MST-1 plus (up) level of -0.85 Vdc; line should have solid up level or go to the up level.
- Indicates nominal MST-1 minus (down) level of -1.85 Vdc; line should have solid down level or go to the down level.
- [1] Plus (up) level is +12 Vdc and minus (down) level is 0 Vdc.
- [2] Special voltages: 0 Vdc and -4 Vdc.
- [3] Cartridge Closed switch is plus (0 volts) when cartridge is fully closed.
- [4] Cartridge Open switch is plus (0 volts) when cartridge is fully open.

3803-2/3420

XC2000 Seq 1 of 2	2735797 Part Number	See EC History	845958 1 Sep 79	846927 20 Jun 80	847298 15 Aug 83		
----------------------	------------------------	-------------------	--------------------	---------------------	---------------------	--	--

© Copyright International Business Machines Corporation 1976, 1979, 1980, 1983

**PNEUMATIC SYSTEM—THEORY**

Two pneumatic pumps supply all vacuum and air pressure required for machine operation.

The distribution of air and vacuum is controlled by a transfer valve, a three-way valve, and an autocleaner solenoid.

Vacuum is used for:

- Tape threading
- Reel loading
- Column loading
- Tape-in-column sensing
- Capstan motor cooling
- Capstan (Model 8 only)
- Tape cleaning

Air pressure is used for:

- Tape threading
- Reels-loaded sensing
- Retracting the tape guides
- Air bearings
- Automatic reel latch
- General machine cooling

**TRANSFER VALVE**

The transfer valve controls the distribution of vacuum, which is different for a thread/load operation than for all other operations.

**THREE-WAY VALVE**

The three-way valve is spring-loaded to the normal Thread Status Inactive position. During Thread Status Active the three-way valve is actuated by the transfer valve solenoid. (See diagram on page 4B-161.)

**AUTOCLEANER SOLENOID**

The autocleaner solenoid controls air pressure to the autocleaner.

**PNEUMATIC SWITCHES**

Pneumatic switches sense the absence or presence of air pressure and vacuum throughout the pneumatic system. The switches indicate the position of tape in the vacuum columns (for reel motor control), the reels loaded condition, air bearing pressure, automatic reel latch pressure, and file protect status.

**AIR BEARINGS**

Air bearings are positioned at three places in the tape path:

1. At the top of the right tapered column.
2. At the bottom of the right tapered column.
3. At the bottom of the left tapered column.

Air is forced through holes in the bearings producing a thin film of air on which tape moves.

**POWER SUPPLY**

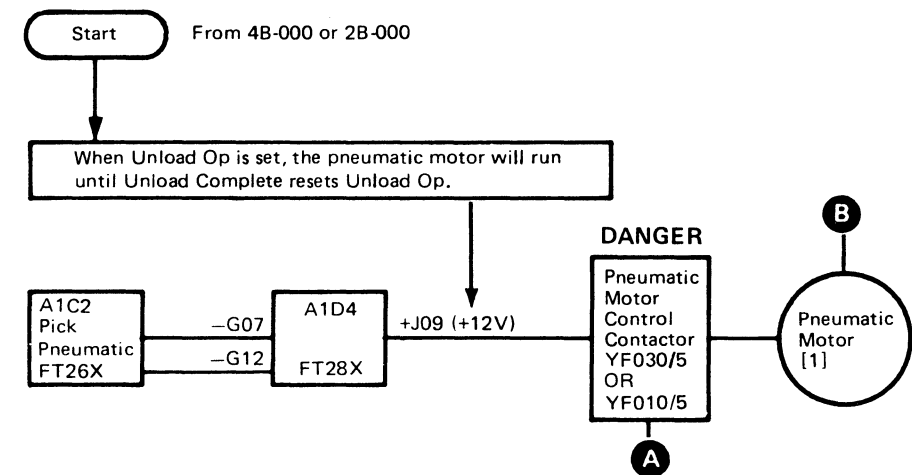
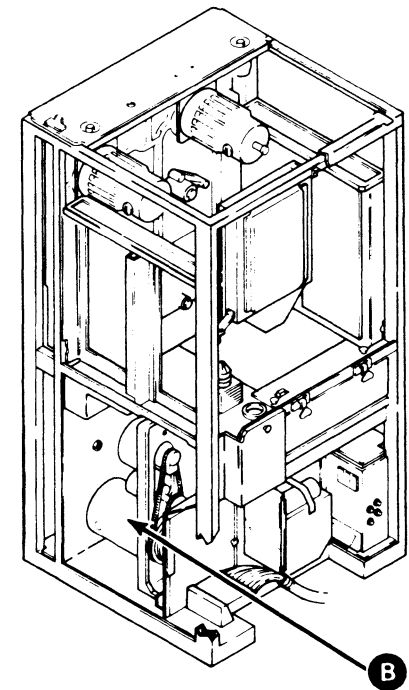
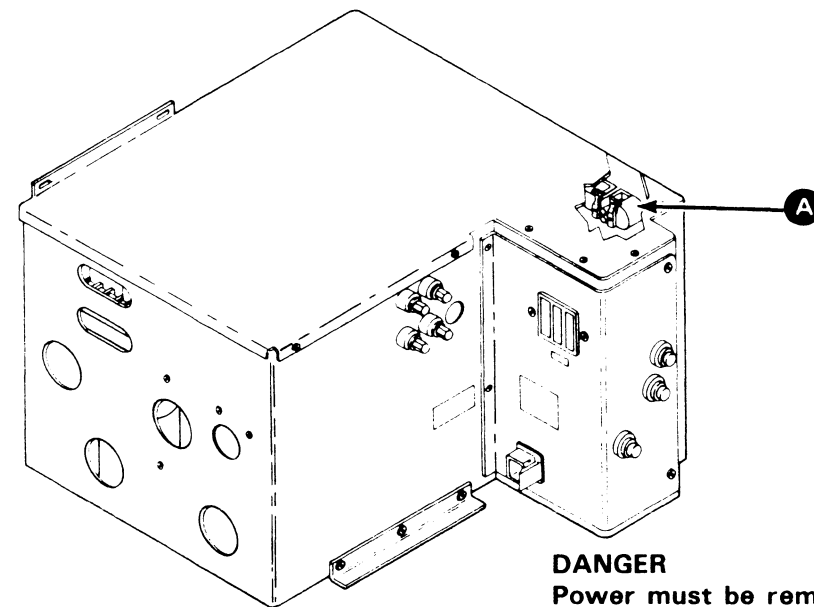

**Notes:**

- + Indicates nominal MST-1 plus (up) level of  $-0.85$  Vdc; line should have solid up level or go to the up level.
- Indicates nominal MST-1 minus (down) level of  $-1.85$  Vdc; line should have solid down level or go to the down level.

[1] Refer to ALD YF030/5 or ALD YF010/5.

3803-2/3420

XC2000 Seq 2 of 2	2735797 Part Number	See EC History	845958 1 Sep 79	846927 20 Jun 80	847298 15 Aug 83			
----------------------	------------------------	-------------------	--------------------	---------------------	---------------------	--	--	--

© Copyright International Business Machines Corporation 1976, 1979, 1980, 1983



# PNEUMATIC SYSTEM

4B-161

## THREAD STATUS ACTIVE

**Note:** Shaded areas in the diagrams show pneumatic distribution in the status identified.

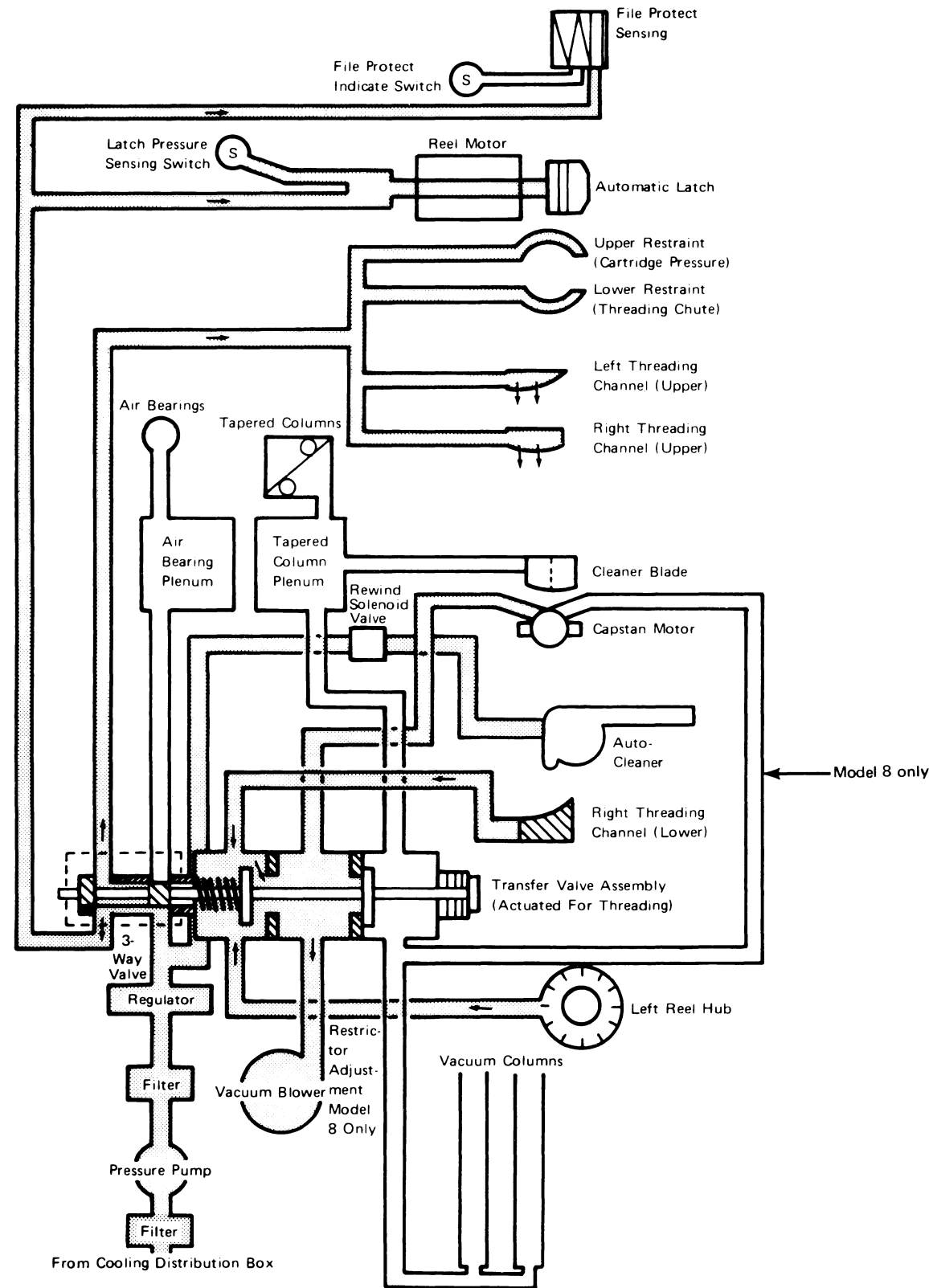

## THREAD STATUS INACTIVE

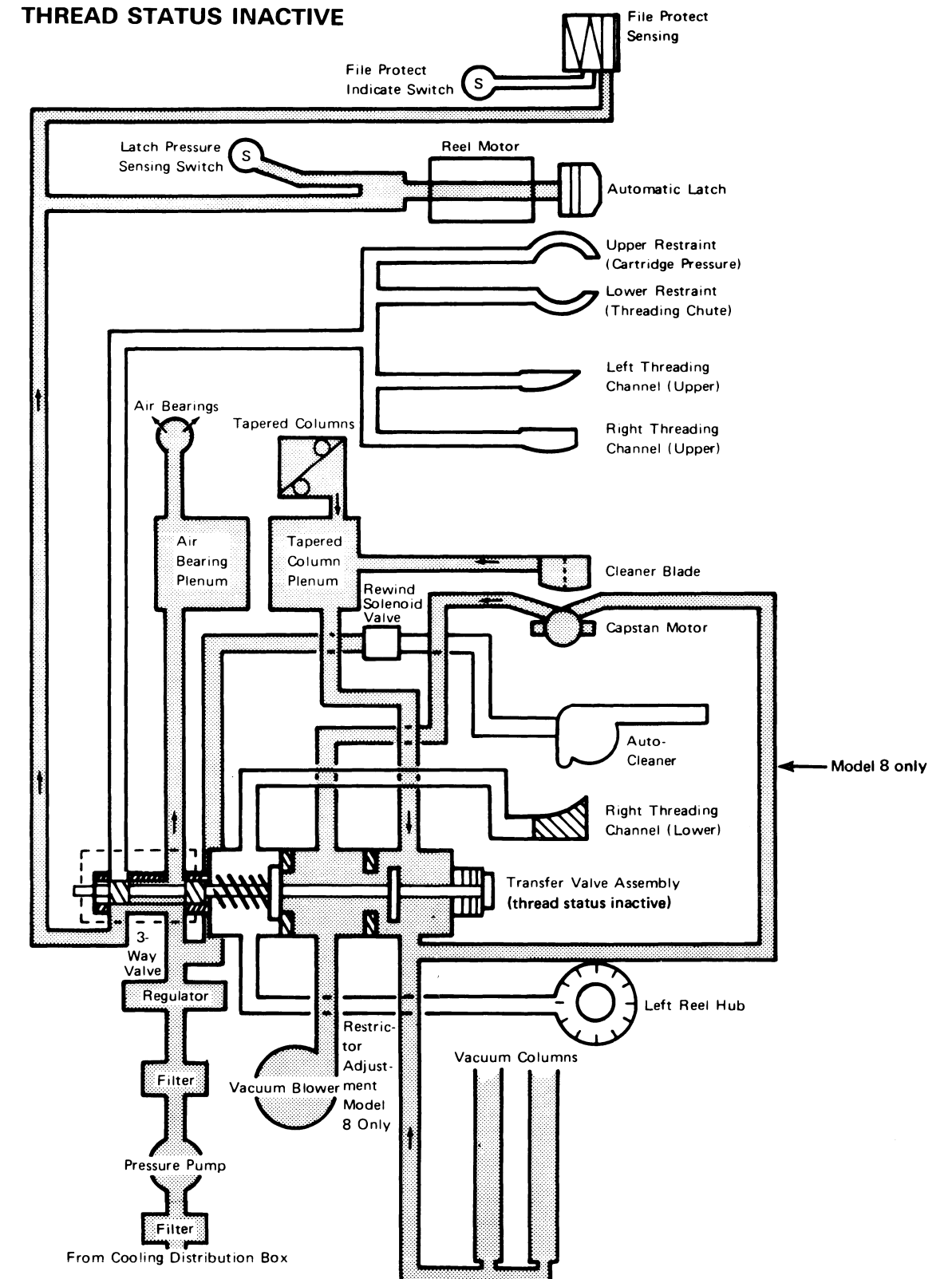

3803-2/3420

XC2050	2736041	See EC	845958			
Seq 1 of 2	Part Number	History	1 Sep 79			

© Copyright International Business Machines Corporation 1976, 1979

4B-161

NOTES:

4B-162

3803-2/3420

XC2050 Seq 2 of 2	2736041 Part Number	See EC History	845958 1 Sep 79					
----------------------	------------------------	-------------------	--------------------	--	--	--	--	--

© Copyright International Business Machines Corporation 1976, 1979

4B-162

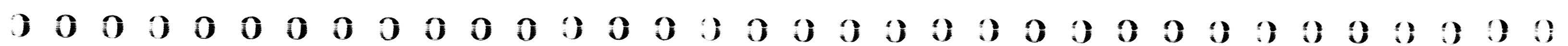

ENVELOPE FAILURE, RUNAWAY, OR READ/WRITE PROBLEMS

5B-000

This map helps sort out possible problems involving the write card, the read/write head, the read card and the erase head, or the read, write, and erase controls in the tape unit logic.

These parts are required for use in the following MAP:  
Read card, Write card, Read/Write head (08-240).

**Note:** Intermittent read/write errors can be caused by a loose pressure manifold on the three-way valve.

**Most Probable Causes:**

1. Read Head card defective
2. Write Head card defective
3. T-A1K2, T-A1L2, T-A1J2, T-A1H2 cards defective
4. R/W head defective
5. Erase head defective
6. Capstan motor

**Initial Checks:**

1. Air pressure and vacuum (see 08-400).
2. -4 Vdc and +6 Vdc power supplies in tolerance (see 08-570).
3. R/W head and cleaner blade must be clean (see Note 1 on 5B-001).
4. Capstan squaring (see 08-120).

If any of the Initial Checks indicate a problem, take action necessary but verify that the original problem still exists before continuing with this MAP (run OLTEP, etc.).

**Always** start with Seq 1 and follow the procedure in sequence unless directed otherwise.  
**Remember** to END all problems or maintenance calls by going to MAP 00-030.

Seq	Condition/Instruction	Action
1	If the problem is permanent data errors or significant temporary errors, go through this map once, then go to 5B-002.	
2	Install the Field Tester. Load the tape unit with a Master Output tape with a write enable ring installed. Make the tape unit ready. Is the File Protect lamp on?	Change in order: 1. T-A1J2 2. Write head card 3. Write card cable 4. Go to 00-030.
3	Install a jumper from K2P02-M2D06. Set the tester for a Write, Fwd, Fast, and St/stp. Put the density switch to 64.	
4	Scope point A on 5B-100. Are all tracks missing or amp low? See note.	Go to Seq 32.
5	Are any tracks missing?	Go to Seq 28.
6	Is the amplitude low or distorted on any track? See examples on 5B-004.	Go to Seq 44.

**Note:**

Sync minus on MOVE COMMAND B at T-A1F2P12.  
Set horizontal at 5ms/cm.  
Set vertical at 0.5v/cm.

Seq	Condition/Instruction	Action
7	Scope digital data at entry point B. Are any tracks missing?	Change in order: 1. Read card 2. T-A1L2 and go to 00-030.
8	Does SAGC fail to set up on any track? Do procedure on 08-315.	Go to Seq 11.
9	If not:	Go to Seq 14.
10	Reserved	
11	Is -6250 (T-A1K2U06) plus?	Change T-A1K2 and go to 00-030.
12	Is +Initiate SAGC (T-A1K2P12) pulsing?	Go to Seq 51.
13	If not:	Change T-A1K2 and go to 00-030.
14	Does the tape unit have PE (1600 BPI) capability?	Rewind tape and remove jumper (K2P02-M2D06). Go to Seq 16.
15	If not:	Go to Seq 22.
16	Set the Field Tester for a Write, Fwd, Fast, and St/stp. Put the density switch to 32 (middle position).	
17	Scope entry point A on 5B-100. Are all tracks 2V ±.3V peak to peak?	Go to Seq 20.
18	Do amp sensor adjustment procedure on 08-310. Are amp sensors within tolerance?	Go to 00-030.
19	If not:	Change in order: 1. T-A1K2 2. Read head card 3. Write head card 4. Go to 00-030.
20	Scope digital signal at entry point B on 5B-100.	
21	Are any tracks missing?	Change the read head card. Go to 00-030.
22	Scope point A on 5B-100. Is the envelope fluctuating on tracks 4 or 5? Shifting due to tape edge damage or wrinkles.	Perform Capstan Dynamic Alignment on page 08-150 or 08-160 and Mechanical Skew on 08-170. Go to 00-030.
23	Write a tape in the same failing density on a working tape unit, or use a CE work tape that has been prewritten at the proper density. This tape may be written on any speed tape unit, using the Field Tester as described in Seq 3 (6250) or Seq 16 (1600).	
24	Read this prewritten tape on the failing tape unit. Set the Field Tester to Read, Fwd, and St/Stp. Scope entry point A on 5B-100. Is the amplitude low, distorted, or missing for any track?	Perform the following procedures: Mechanical Skew 08-170. Read amplitude adjustment 08-310 Pneumatic adjustment 08-400 and 08-405. Go to 00-030.

Seq	Condition/Instruction	Action
25	Scope entry point B on 5B-100. Are any tracks missing?	Change in order: 1. T-A1L2 2. Read head card 3. Go to 00-030.
26	Disconnect the interface cable at the tape unit and put the ONLINE/OFFLINE switch in the ONLINE position. Scope points at entry F on 5B-100. Are any tracks missing?	Replace T-A1L2, reconnect the interface cable and go to 00-030.
27	Put the ONLINE/OFFLINE switch to OFFLINE and reconnect the interface cable. Go to 5B-002.	
28	Write a tape in the same failing density on a working tape unit, or use a CE work tape that has been prewritten at the proper density. This tape may be written on any speed tape unit using the Field tester as described in Seq 3.	
29	Read this prewritten tape on the failing tape unit. Set Field Tester to Read, Fwd, and St/Stp. Scope point A on 5B-100. Are any tracks missing?	Change in order: 1. Read head card 2. Read/write head 3. T-A1K2 4. Go to 00-030.
30	Problem appears to be a write problem. Check voltages at entry point D on 5B-100. Are voltages within tolerance? See 08-570 for tolerances.	Change in order: 1. Write card 2. Read/write head 3. T-A1K2 4. Go to 00-030.
31	If not:	Adjust/Repair/Replace Go to 00-030.
32	Is the auto cleaner operating correctly. See 08-380.	Go to Seq 36.
33	Is -Pick Solenoid (T-A1G2P10) plus (+12 Vdc) when tape unit is loaded and not moving tape?	Change T-A1G2. If problem still exists go to Seq 35 otherwise go to 00-030.
34	Is -Pick Solenoid (T-A1G2P10) minus (0 Vdc) during a high speed rewind?	Change T-A1G2. If problem still exists go to SEQ 35, otherwise go to 00-030.
35	If not:	The problem is either a bad cable between T-A1N7 and the solenoid, a loose or crimped pneumatic hose to the auto cleaner, or a defective auto cleaner. Go to 00-030.

3803-2/3420

XC2100	2735798	See EC History	845958	846927	847298		
Seq 1 of 2	Part Number		1 Sep 79	20 Jun 80	15 Aug 83		

5B-000

Seq	Condition/Instruction	Action
36	Is T-A1M2M10 at +6 volts?	Go to Seq 38.
37	If not:	Change in order: 1. T-A1K2 2. File protect switch 3. Write enable relay For further analysis see Ald ZT071. Go to 00-030.
38	Is +Write Status (T-A1K2M05) plus? [4]	Go to Seq 41.
39	Is -Write Status (T-A1J2M12) minus?	Change T-A1K2 and go to 00-030.
40	If not:	Change T-A1J2 and go to 00-030.
41	Scope inputs to write card at entry point H on 5B-100. Are all outputs to A1J2 pulsing?	Go to Seq 28.
42	Scope inputs to A1J2 at entry point J on 5B-100. Are all inputs pulsing?	Change in order: 1. T-A1J2 2. Write head card 3. Write card cable 4. Go to 00-030.
43	If not:	Change T-A1K6.
44	Check the voltage at entry points D and E.	
45	Are voltages within tolerance?	Go to Seq 47.
46	If not:	Adjust/Repair/Replace Go to 00-030.
47	Scope A1J2 outputs at entry point H. Are any tracks missing or distorted?	Change T-A1J2 and go to 00-030.
48	Write a tape in the same failing density on a working tape unit, or use a CE work tape that has been prewritten at the proper density. This tape may be written on any speed tape unit using the procedure described in Seq 3.	
49	Read this prewritten tape on the failing tape unit. Set Field Tester to Read, Fwd, and St/stp. Scope point A on 5B-100. Is the amplitude low or envelope distorted?	Change in order: 1. Read head card 2. Read/write card 3. T-A1K2 4. Go to 00-030.
50	Problem appears to be a write problem.	Change in order: 1. Write head card 2. Read/write head 3. Go to 00-030.
51	Measure the read head resistance for the failing track. See the procedure on 5B-001. Is the resistance good?	Change in order: 1. Read head card 2. T-A1K2 3. Go to 00-030.
52	If not:	Change the read/write head. Do 08-250 and then go to 00-030.

R/W HEAD RESISTANCE CHECK PROCEDURE

1. Turn off tape unit power.
2. Remove the read/write card shroud. Disconnect the read/write cards from the head and slide them back even with the transport casting.
3. Use a calibrated \*Simpson meter, not the CE tool bag meter. Measure the resistance across each track of the head. Ignore the center tap of the coil. The normal reading on the write side is 1.7 ohms. Reject point on the write side is 5 ohms or greater. The normal resistance of a read track is 3.6 ohms. Reject point on the read tracks is 10 ohms or greater. Measure from center tap to each side of the read and write coils. The resistance should be approximately equal.
4. Reinstall the read and write cards and the card shroud.
5. Degauss Read/Write head (see 08-280).

Figure C. Read/Write Head

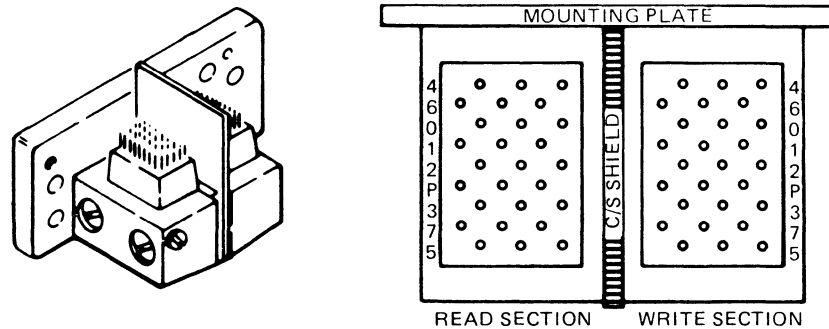
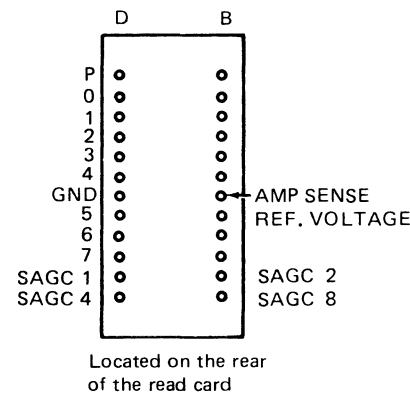
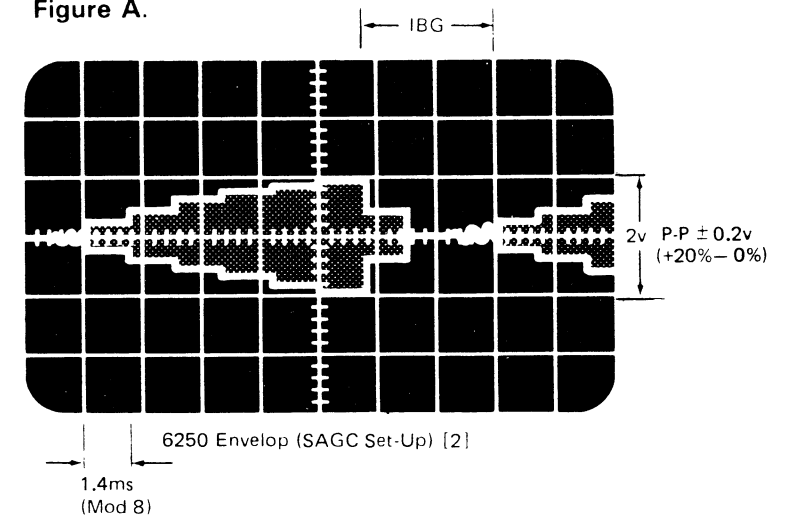

Figure D. Read Card Test Points



\*Trademark of Simpson Electric Co.

Figure A.



Notes:

- [1] If all tracks are missing, check autocleaner for proper operation.
- [2] For 6250 operations, an external jumper must be installed between T-A1K2P02 and T-A1M2D06. Vary Go Up time to observe a full SAGC set up. This requires approximately 20 ms at 200 ips, 35 ms at 125 ips, and 55 ms at 75 ips. A SAGC check is set at 15 steps on a write, 16 steps on a read.
- [3] Inform the customer of the importance of an adequate cleaning schedule. Check the autocleaner for proper operation (see 08-360 and 08-380), correct air pressure and clear air bearing ports.
- [4] Special Voltage: Minus level is 0 Vdc, plus level is +3.0 Vdc

3803-2/3420

XC2100 Seq 2 of 2	2735798 Part Number	See EC History	845958 1 Sep 79	846927 20 Jun 80	847298 15 Aug 83		
----------------------	------------------------	-------------------	--------------------	---------------------	---------------------	--	--

© Copyright International Business Machines Corporation 1976, 1979, 1980, 1983

PERMANENT DATA CHECKS

5B-002

This MAP covers adjustments and service checks not previously covered.

**Most Probable Causes:**

- Media (see 00-011)
- Read head card
- R/W head (head may be dirty)
- Write head card
- Capstan motor
- T-A1L2, T-A1J2, T-A1K2
- Vacuum column door adj.
- Transfer valve
- Loose pneumatic hoses
- Erase head
- Worn or dirty cleaner blade

**Always** start with Seq 1 and follow the procedure in sequence unless directed otherwise. **Remember** to END all problem or maintenance calls by going to MAP 00-030.

Seq	Condition/Instruction	Action
1	Does the error occur on more than one tape?	Go to Seq 3.
2	Is the failing tape available for analysis?	Go to 00-011 Permanent Read/Write Error Analysis.
3	Problem may be Media related. Assure tape unit is clean and do the following procedures to assure tape unit meets criteria.	
4	Set up the Field Tester for a Write, Fwd, St/stp, and the density switch set to 64. Jumper K2P02-M2D06. Move tape away from load point and then set tester to Stop.	
5	Do power supply checks on 08-570. Check with the tape unit loaded and in write status. Then check entry points D and E on 5B-100 for proper voltage.	
6	Are voltages within tolerance?	Go to Seq 8.
7	If not:	Adjust/Repair/Replace Go to 00-030.
8	Is -Erase Head on (T-A1G2D11) minus?	The tester should have been in write stop mode for at least 5 minutes. Go to Seq 11.
9	Is +Erase Status (T-A1K2U04) plus?	Go to Seq 12.
10	If not:	Change T-A1K2 and go to 00-030.
11	Is the erase head warm? Unload the tape unit, open the vacuum column door, and feel the erase head.	Go to Seq 16.
12	Unplug the write head cable from the write card and check the erase head for an open or a short. Resistance should be approximately 22 ohms.	

Seq	Condition/Instruction	Action
13	Is the erase head open or shorted?	Change the erase head and go to 00-030.
14	Is the resistance correct?	Change in order: 1. Write head card 2. T-A1G2 3. Go to 00-030.
15	If not:	Replace erase head. Go to 00-030.
16	Pneumatic leaks can cause intermittent read/write problems. Do procedure on 6B-150.	
17	Procedure check good?	Go to Seq 19.
18	If not:	Adjust/Repair/Replace Go to 00-030.
19	A worn or gassed cleaner blade can cause read/write errors. Do procedure on 08-390 and examine cleaner blade for a worn condition.	
20	Does cleaner blade check good?	Go to Seq 22.
21	If not:	Replace or degauss cleaner blade. Go to 00-030.
22	Check the forward to backward ratio on the head. See 08-240. Is the ratio within tolerance?	Go to Seq 24.
23	If not:	Replace the read/write head per 08-250. Go to 00-030.
24	Check feedthrough. Do procedure on 08-330. Is feedthrough within tolerance?	Go to Seq 26.
25	If not:	Replace the read/write head. Go to 00-030.
26	Disconnect the tape interface cable. Put the ONLINE/OFFLINE switch to ONLINE. Set the Field Tester to Write, Fwd, St/stp, and put the density switch to 64. Scope entry point F on 5B-100. Do any of the tracks have noise in the IBG (see 5B-025)?	Go to Seq 28.
27	If not:	Go to Seq 35.
28	Is there noise in the IBG at entry point B on 5B-100?	Go to Seq 30.
29	If not:	Change T-A1L2 and go to 00-030.
30	Is -Zero threshold minus for the track that has noise in the IBG (entry G)?	Change T-A1K2 and go to 00-030.

Seq	Condition/Instruction	Action																					
31	Is there noise at entry H on 5B-100?	Go to Seq 33.																					
32	If not:	Change in order: 1. Read head card 2. Write head card 3. Read/write head 4. Go to 00-030																					
33	Is there noise at entry J on 5B-100?	Change T-A1K6 and go to 00-030.																					
34	If not:	Change T-A1J2 and go to 00-030.																					
35	Set tester to St/stp mode and adjust Go Up and Go Down so that -Move (T-A1K2D07) is minus for at least 20 ms for Model 8, 35 ms for Model 6, or 55 ms for Model 4. Is +SAGC check (T-A1K2G08) pulsing? (May be intermittent)	Go to Seq 41.																					
36	Refer to Section 12-000 (CE Panel Operation) and set up CE panel to loop continuously as follows:  CMND1 = 01X CMND2 = 01X CMND3 = 01X CMND4 = 07X  Sync positive external on +Initiate SAGC (T-A1K2P12). Display Entry A, tracks P through 7 (see 5B-100) on Channel A of scope. Display Entry G, tracks P through 7 on Channel B of scope.																						
37	Does -Zero Threshold (entry G) go minus for the first three records following the initial SAGC burst?  <b>Note:</b> The records seen following these are being induced during the rewind operation.	Go to Seq 39.																					
38	If not:	Change T-A1K2 and go to 00-030.																					
39	Check amp sense reference voltage at entry A for the following modes:  <table border="1"> <thead> <tr> <th>Voltage</th> <th>Level</th> <th>Mode</th> </tr> </thead> <tbody> <tr> <td>0.1 V</td> <td>10%</td> <td>Read (IBG)</td> </tr> <tr> <td>0.2 V</td> <td>20%</td> <td>Write (6250)</td> </tr> <tr> <td>0.8 V*</td> <td>80%</td> <td>PE Low</td> </tr> <tr> <td>0.9 V</td> <td>90%</td> <td>Set SAGC</td> </tr> <tr> <td>1.0 V</td> <td>100%</td> <td>PE</td> </tr> <tr> <td>1.2 V*</td> <td>120%</td> <td>PE High</td> </tr> </tbody> </table> *Set by a Diagnostic Mode Set command. (See decal on fan assembly in the 3803.) Are any of the voltages incorrect?	Voltage	Level	Mode	0.1 V	10%	Read (IBG)	0.2 V	20%	Write (6250)	0.8 V*	80%	PE Low	0.9 V	90%	Set SAGC	1.0 V	100%	PE	1.2 V*	120%	PE High	Change read head card. Go to 00-030.
Voltage	Level	Mode																					
0.1 V	10%	Read (IBG)																					
0.2 V	20%	Write (6250)																					
0.8 V*	80%	PE Low																					
0.9 V	90%	Set SAGC																					
1.0 V	100%	PE																					
1.2 V*	120%	PE High																					

3803-2/3420

XC2200 Seq 1 of 2	2735799 Part Number	See EC History	845958 1 Sep 79	846927 20 Jun 80				
----------------------	------------------------	-------------------	--------------------	---------------------	--	--	--	--

© Copyright International Business Machines Corporation 1976, 1979, 1980

5B-002

PERMANENT DATA CHECKS (Cont'd)

5B-003

Seq	Condition/Instruction	Action
40	All major adjustments have been performed. Run all Read/write diagnostic procedures then return the subsystem to the customer.	Go to 00-030.
41	Does SAGC set up on all tracks? <b>Note:</b> The SAGC will take fewer steps to set up using the field tester than using the tape control unit. Write frequency directly affects the initial amplitude. Refer to 08-315 for proper SAGC setup.	You may have false SAGC check. Change the Read head card. Go to 00-030.
42	Measure read head resistance for the failing track. Is the resistance good. See procedure on 5B-001.	Change read head card and go to 00-030.
43	If not:	Change read/write head and go to 00-030.

3803-2/3420

XC2200	2735799	See EC	845958	846927				
Seq 2 of 2	Part Number	History	1 Sep 79	20 Jun 80				

© Copyright International Business Machines Corporation 1976, 1979, 1980

5B-003



ACCEPTABLE WAVEFORMS (READ CARD TEST POINTS)

5B-004

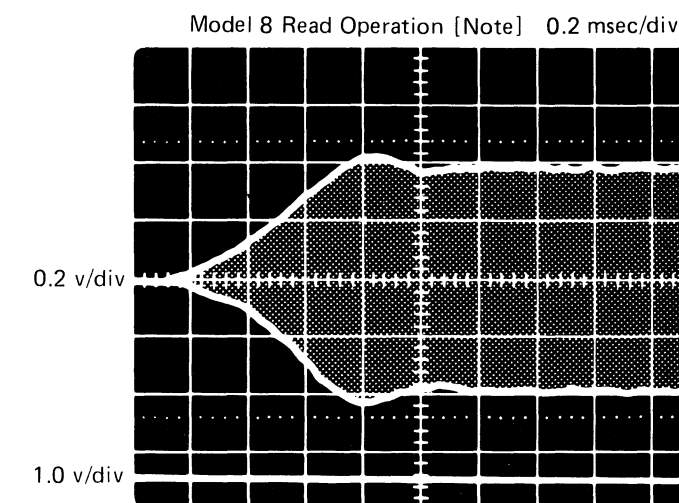
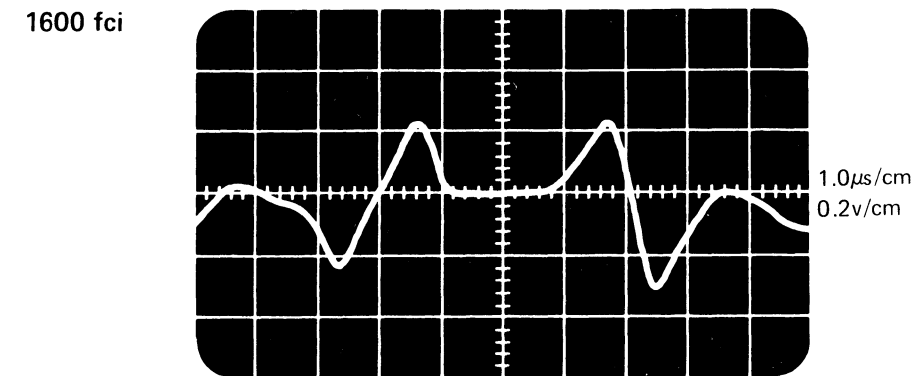
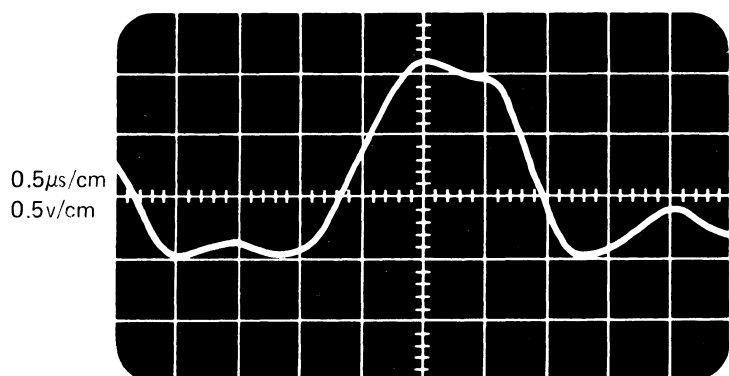
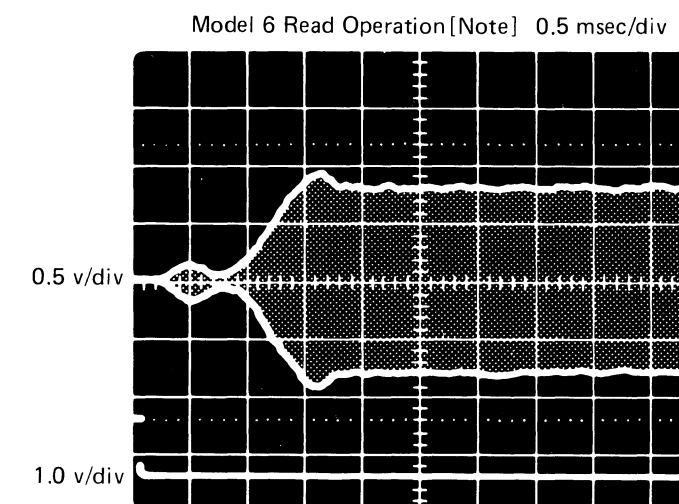
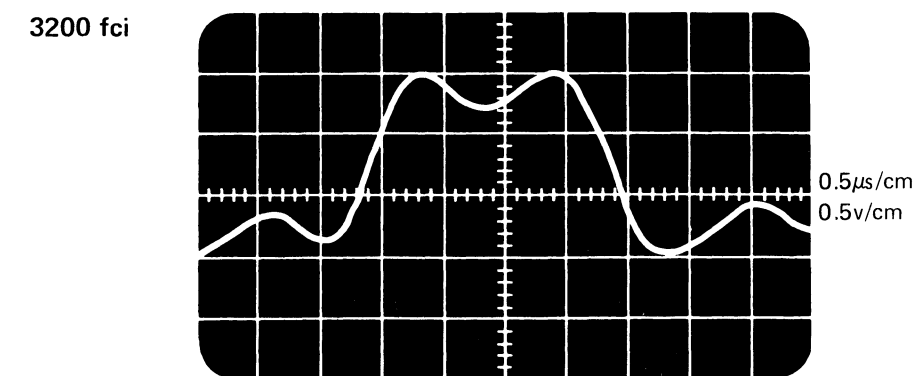
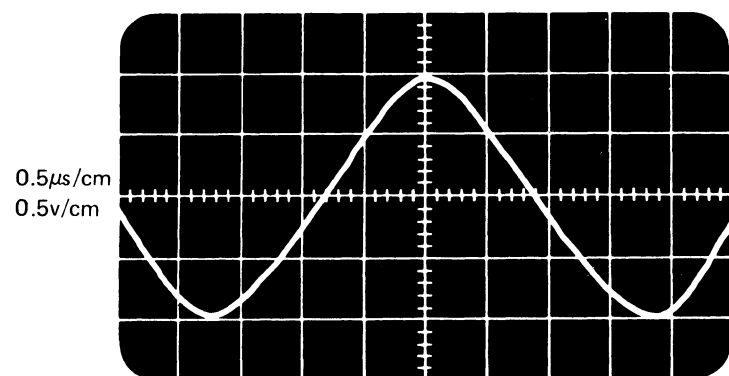
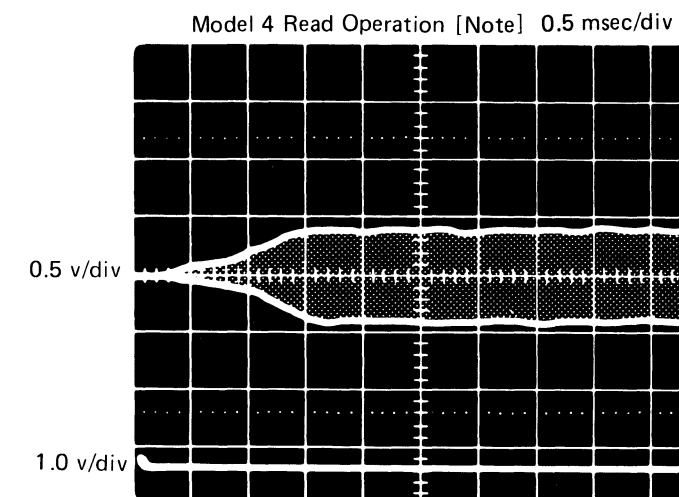
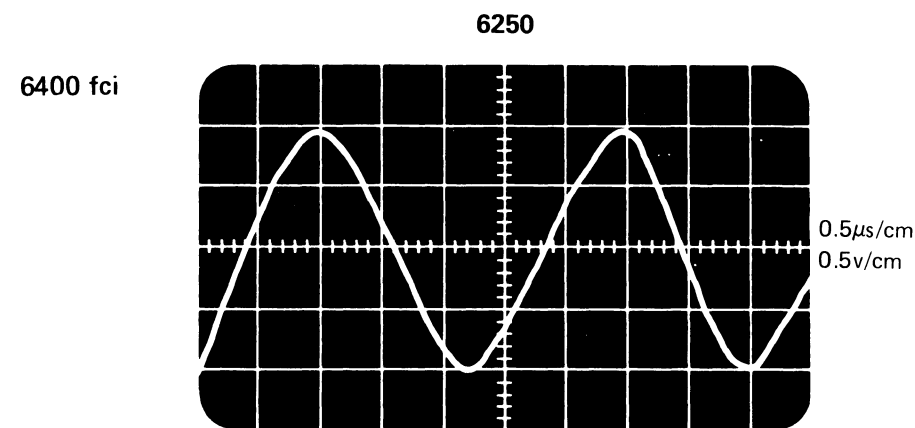
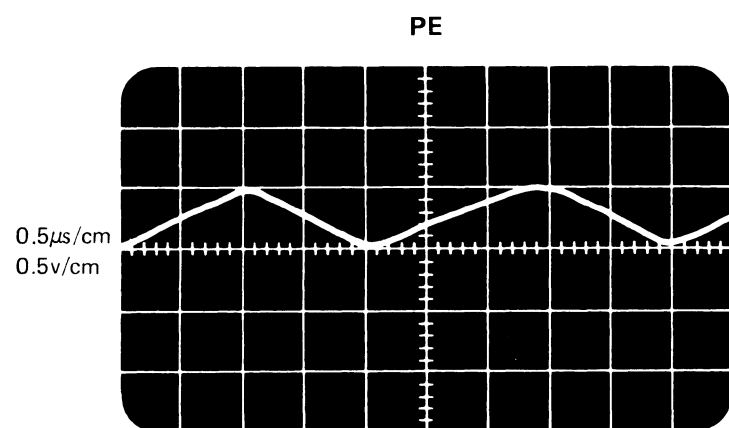

**Note:** Read a tape which was previously written continuously from the field tester in 6250 mode.

3803-2/3420

XC2220	8492586	See EC	845958	846927				
Seq 1 of 2	Part Number	History	1 Sep 79	20 Jun 80				

© Copyright International Business Machines Corporation 1976, 1979, 1980

5B-004

# READ FORWARD TO BACKWARD RATIO TEST (MODELS 4, 6, 8)

Use this test to help determine if a read/write head needs replacement.

Verify that the tape is tracking correctly before any head replacement because of the above criteria. Perform Field Accuracy check on 08-315 before proceeding.

1. Degauss the head (08-280) and the cleaner blade (08-390).
2. Install a jumper from K2P02-M2D06. This forces 6250 mode.
3. Obtain a customer good quality representative tape and write it at 6250 bpi on the unit being checked. Write it from the field tester with the frequency switch set at 64.
4. Read forward to the middle of the tape and remove jumper K2P02-M2D06 while tape is moving, then stop tape.
5. Set the Field tester as follows:  
ALT DIR  
SLOW  
READ  
UP/FWD DN/BKWD. potentiometers all the way to the back of the tester.  
(Adjust DN/BKWD. so tape has a forward creep rather than a backward creep).
6. Sync and scope the Read card test points to determine the fwd to bkwd ratio. Display 3 or 4 cycles of read signal and use as much of the scope display as possible for measurements (.2v/cm). For ease of recording, scope H2M08 with another probe, this line will go negative when reading backwards.

## BACKWARD

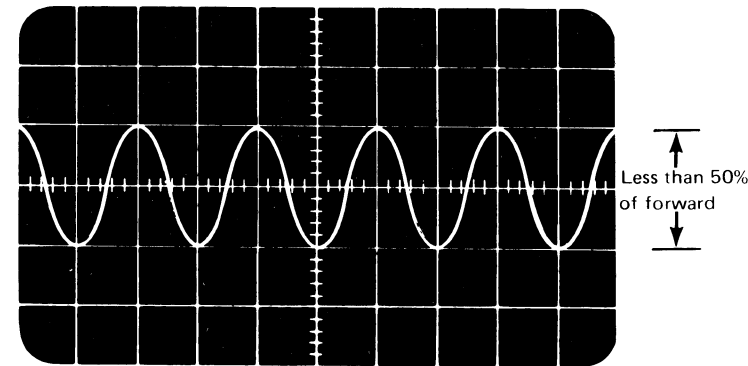

7. If there is a read problem, and the amplitude in one direction is more than double the amplitude in the opposite direction on any one track, replace the read/write head. If read/write head replacement is required, perform the removal/replacement procedure on 08-250, do required adjustments and return to the MAP that sent you here or 00-030. If replacement is not required return to the MAP that sent you here or 00-030.

**Note:** If while making measurements, the tape gets back to load point, (resetting the 6250 latch) the jumper K2P02-M2D06 will have to be reinstalled while at load point and the tape read forward. This keeps the tape unit in 6250 without forcing a SAGC set up on every record. Remove the jumper and continue the test.

Each time the jumper is removed the SAGC may set up at a different amplitude, but the ratio will remain the same.

## SIGNAL DROPOUT

**Note:** Signal dropout can be caused by improper vacuum and air pressure levels, plugged air bearings and glazed capstan. It is imperative that the MAP on 5B-000 be completed before this procedure is attempted.

Scope failing record and other records on the failing tape and compare signal envelopes as follows:

1. Set up tape control unit to read forward and backward over the failing record.

2. Sync scope on -Go Forward and probe the read card envelope for each track for signal dropout. If signal dropout exists on the failing record only, suspect media.

Read card envelope track with signal dropout (see item 2 above).

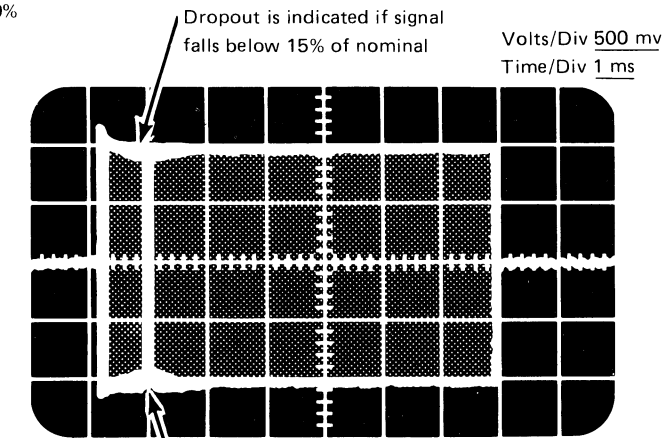

See **A** for expanded view of this area

**A** Expanded view of dropout region of read card envelope.

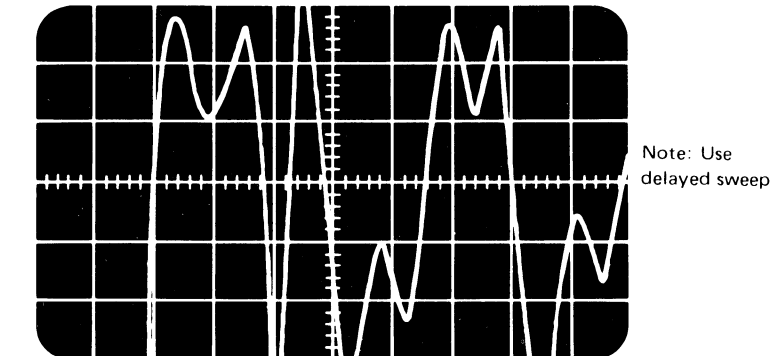

If signal between amplitude nulls and ground reference drops below 50 mv errors can occur.

## TAPE STRETCH

Another type of tape damage is tape stretch. Look for a narrowing of the tape as shown.

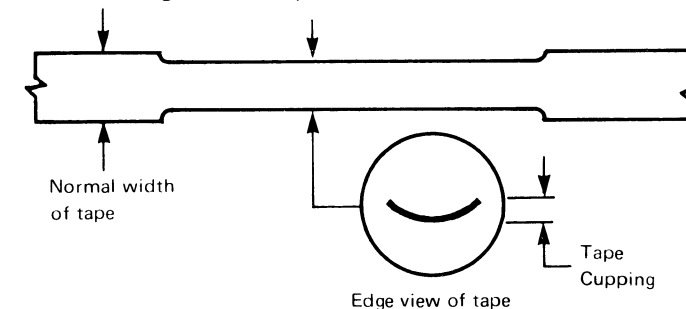

When the stretched section of tape is held in a loop it distorts. Stretched tape usually occurs near the beginning of the reel or in the area of high speed to slow rewind.



## TAPE SLIPPING

To check for tape slipping, scope the failing record Sync on any forward operation and scope the read card test points. Tape slip is indicated by a dropoff of signal amplitude near the end of the record.

Depending on length of the record and the scope setting, the signal may be difficult to detect. If so expand and delay sweep on scope to the end of the record. See examples below.

**Note:** Problem caused by the tape unit that wrote the tape.

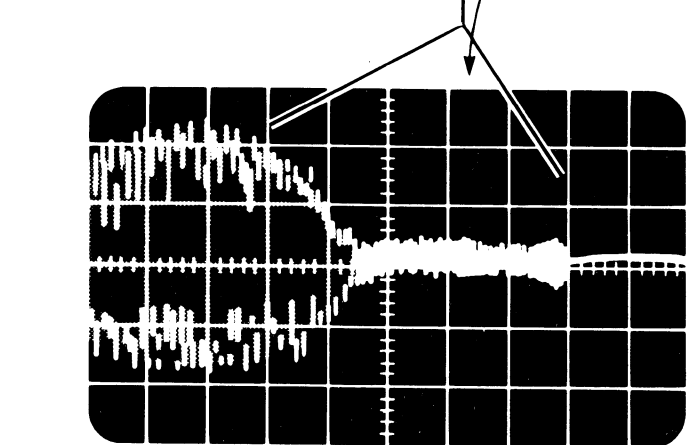
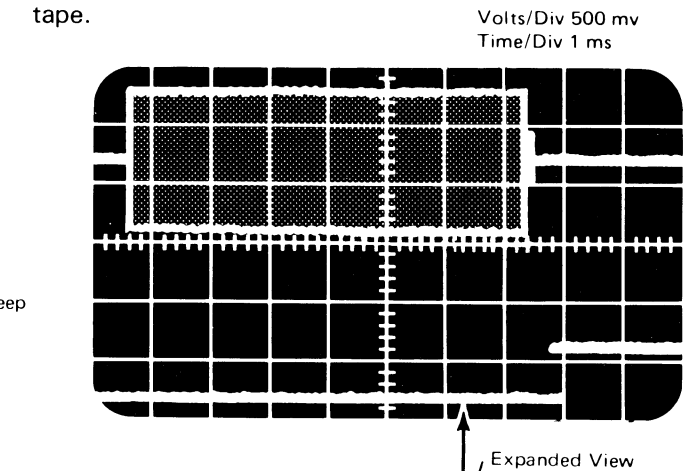

## FORWARD

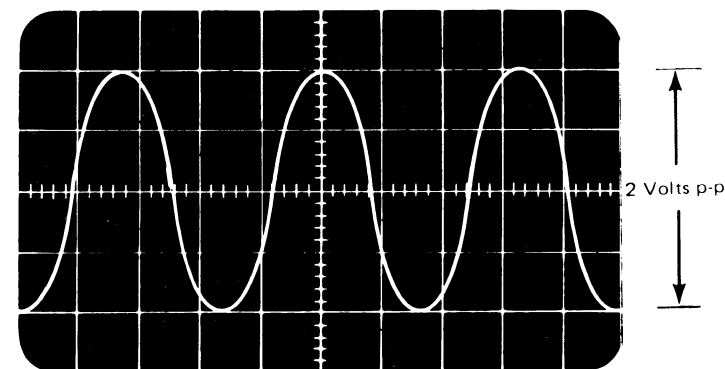

3803-2/3420

XC2220	8492586	See EC	845958	846927				
Seq 2 of 2	Part Number	History	1 Sep 79	20 Jun 80				



## TAPE SLIPPING (Cont'd)

5B-025

Tape slip usually occurs during dynamic reversal while performing an Erase Gap command. Tape slip causes the tape to be incorrectly positioned. When the write head becomes active it then erases part of the previous record. (The record before the error record that the Erase Gap command was supposed to erase.)

Developing the tape shows the postamble missing on the previous record. For details of tape developing instruction, see 00-011.

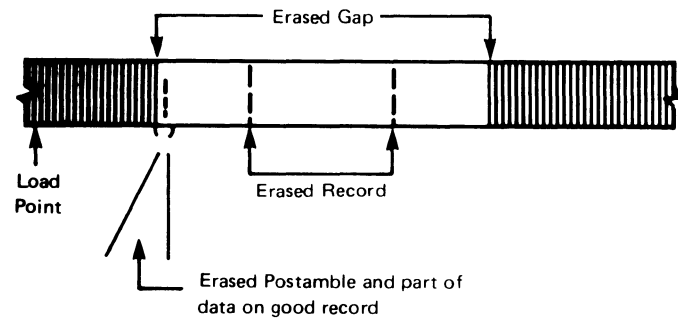

Possible causes of tape slip:

- Loss of capstan vacuum on Model 8
- Drag in the tape path
- Dirty air bearings
- Low air pressure
- High or low vacuum
- Vacuum column door glass leakage
- Damaged or dirty capstan surface

## NOISE OR BITS IN THE INTERBLOCK GAP

To detect interblock gap errors, sync scope on -Go Forward. Read forward and backward over the failing record. Display the record in both directions and look for noise in the gap (see diagrams below).

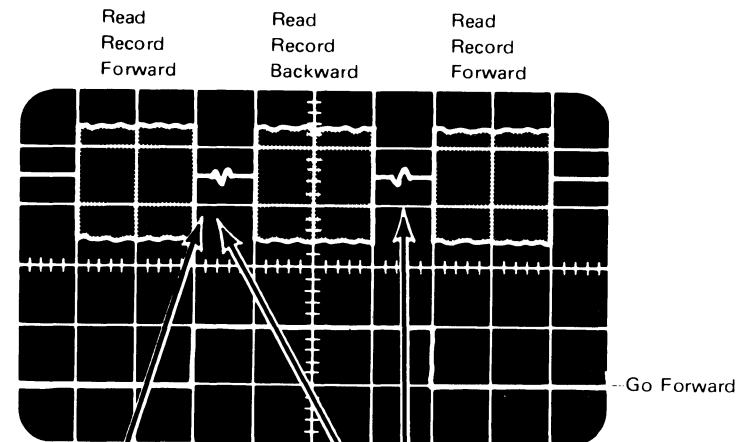

Look for noise in the interblock gap. Amplitude is very low (tape speed is slow).

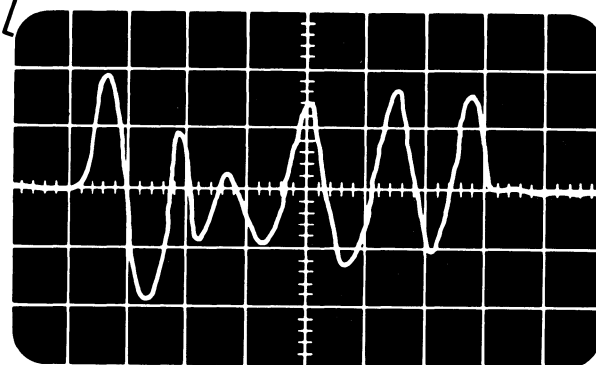

Expanded view of interblock gap.

Developing the tape with noise in the interblock gap shows bits written in the area between two records (sometimes faintly recorded).

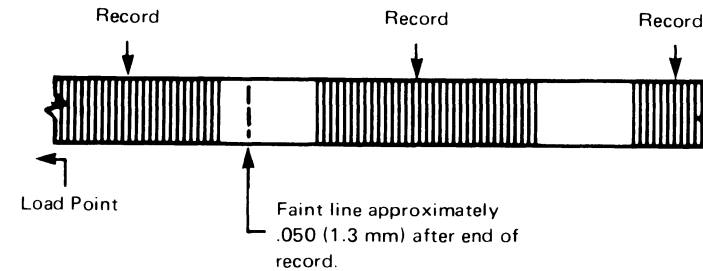

- Gaussed or magnetized Read/Write Head.
- Erase head not working.

## BIT PACKING

Bit packing due to varying capstan speed or tape slipping.

### BIT PACKING SCOPING PROCEDURE

Using the 3803 subsystem offline or using Friend online, mount the failing tape and read out to a failing record. When a failing record has been found, enter the following commands:

- Read (02)
- Backspace Record (27)
- Read (02)
- Backspace Record (27)

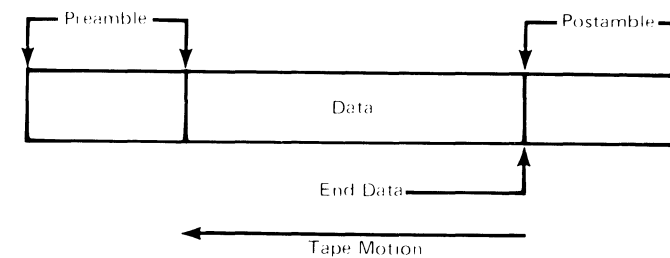

Sync scope on END DATA and scope one of the data tracks at the tape drive or control unit. Measure the length of the postamble in micro-seconds. Then enter the following commands:

- Read Backward (0C)
- Forward Space block (37)
- Read Backwards (0C)
- Forward Space block (37)

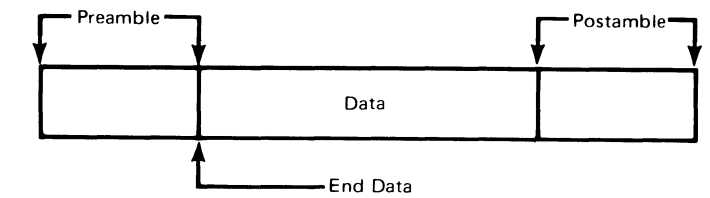

Sync the scope on END DATA while scoping one of the digital data tracks at the tape drive or control unit.

If the preamble is less than the postamble by greater than 20%, the preamble is "packed" and may cause drive failures.

Possible Causes of Bit Packing:

- Tape slip when written
- Dented capstan
- Vacuum and air pressure out of specification
- Plugged air bearing
- Improper operation of digital to analog converter (DAC)
- Defective capstan control board
- Binds in capstan motor

3803-2/3420

XC2250 Seq 1 of 2	4169700 Part Number	See EC History	845958 1 Sep 79				
----------------------	------------------------	-------------------	--------------------	--	--	--	--

© Copyright International Business Machines Corporation 1976, 1979

5B-025

# TAPE EDGE DAMAGE

5B-030

Scope the outside tracks (4 and 5 on 9-track drives) or (P and 7 on 7-track drives) on the failing record. Look at the amplitude changes.

Developing the tape will show bits that were recorded on the tape and the tape was damaged after it was written. This type of damage is usually caused by improper tape handling.

### Example

The tape reel has uneven wraps and the sides of the reel are squeezed creasing the tape.

3803-2/3420

XC2250	4169700	See EC	845958					
Seq 2 of 2	Part Number	History	1 Sep 79					

5B-030



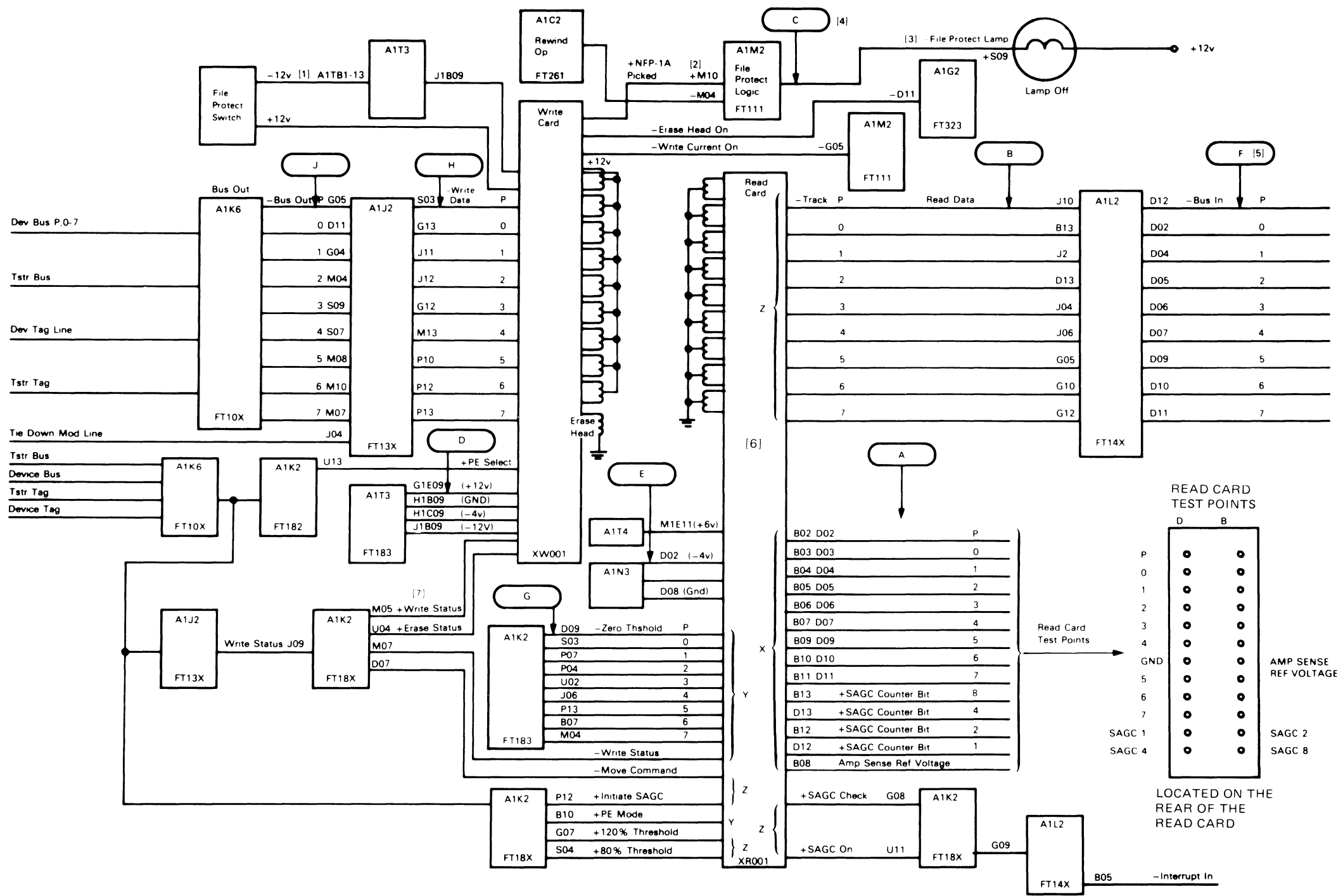

Notes:

- [1] A1TB1-13 is located just to the left of the logic board.
- [2] Special voltage levels: -2 Vdc to +7 Vdc.
- [3] Special voltage levels: 0 Vdc to +12 Vdc.
- [4] Entry C goes only to the File Protect line.
- [5] These lines are degated by the Online/Offline switch. To scope, unplug I/O signal cable and set switch to Online.
- [6] Read card connector X is the test socket at the rear of the card. Y connects to T4 and Z connects to N3 on the logic board. The write card connector goes to T3 on the logic board. See ALD XR001 and XW001 for cable and read/write card pins. T3 and T4 are cable sockets in the top of the logic board.
- [7] Special voltage level: 0.0 Vdc to +3.0 Vdc

3803-2/3420						
<b>XC2300</b>	<b>2735800</b>	<b>See EC History</b>	<b>845958</b>	<b>846927</b>	<b>847298</b>	
Seq 1 of 2	Part Number		1 Sep 79	20 Jun 80	15 Aug 83	

NOTES:

5B-101

3803-2/3420

XC2300 Seq 2 of 2	2735800 Part Number	See EC History	845958 1 Sep 79	846927 20 Jun 80	847298 15 Aug 83			
----------------------	------------------------	-------------------	--------------------	---------------------	---------------------	--	--	--

© Copyright International Business Machines Corporation 1976, 1979, 1980, 1983

5B-101



# AUTOCLEANER

5B-110

The autocleaner cleans the read/write head and the tape recording surface by means of a cleaning ribbon positioned across the tape between the tape and the read/write head during a Rewind or Rewind Unload operation.

## ERASE HEAD

The erase head is active during Write, write tape mark (WTM), Erase, and data security erase (DSE) operations.

When a read-to-write status change occurs, it is necessary to backhitch until the erase head is positioned in the interblock gap after the last good record. This is necessary because the write head is not used for erasure on Models 4, 6, and 8.

## WRITE HEAD, ERASE HEAD, AND WRITE CARD CIRCUITS

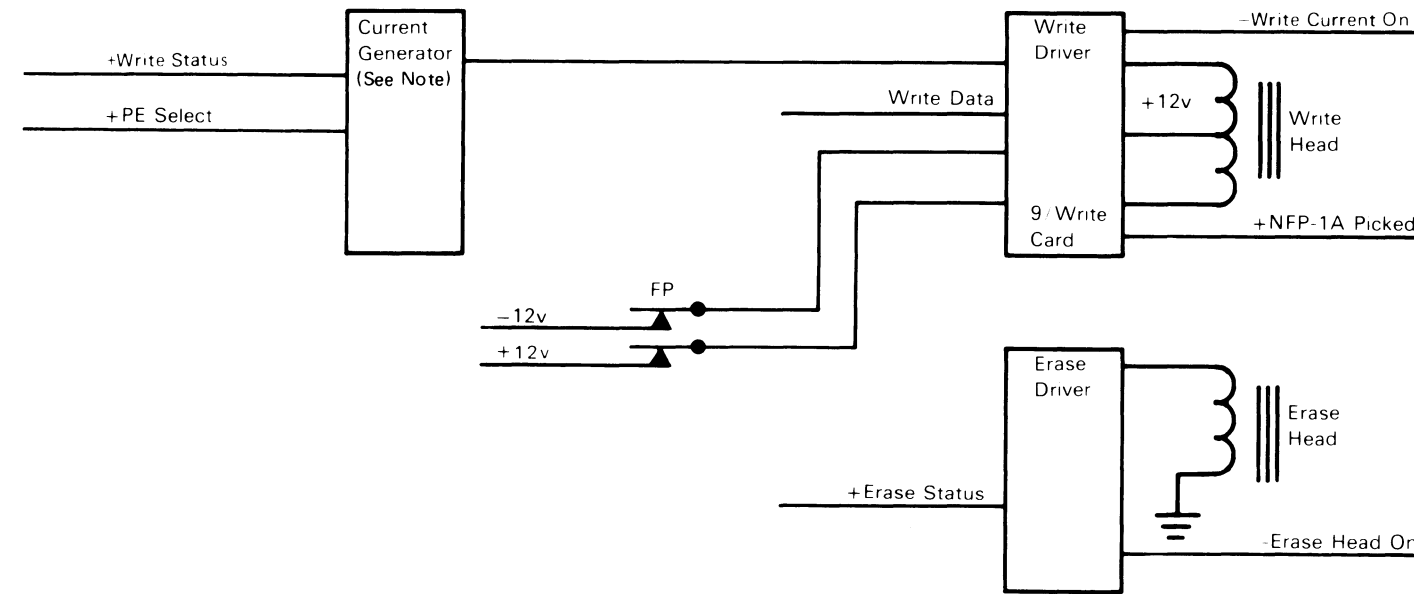

**Note:** The Current Generator sets the appropriate write driver currents for 1600 bpi and 6250 bpi operations.

3803-2/3420

XC2400 Seq 1 of 2	2735801 Part Number	See EC History	845958 1 Sep 79				
----------------------	------------------------	-------------------	--------------------	--	--	--	--

© Copyright International Business Machines Corporation 1976, 1979

5B-110

ZERO THRESHOLD

This line is active during the read data portion of a Read operation. It bypasses the amplitude sensor gate, allowing the limiter to pass any signal (noise or data).

SELF-ADJUSTING GAIN CONTROL

In 6250 bpi mode, the SAGC compensates for amplitude variations in the signal read from tape (tape output, head output, circuit gain). The amplitude of the read signal into the limiter and amplitude sensor at either test point should be 2.0 volts peak-to-peak (referenced to ground)  $\pm 15\%$ . Online, amplitude is set automatically at the beginning of each reel of tape while reading the all-ones data burst (which follows the ID burst). Offline, amplitude is set at the beginning of each record when using the field tester with a jumper installed from T-A1K2P02 to T-A1M2D06.

The amplitude-setting sequence is started by a positive pulse on the Initiate SAGC line, which sets the SAGC latch and resets a five-bit counter to zero. +SAGC On is sent to the reference generator and the tape control. The reference generator sets the amplitude sensor threshold to 90% (0.9 V) (see TP 2 **1**). When the +Initiate SAGC pulse returns negative, the counter starts stepping. Each time the counter advances, the amplifier gain for each track is increased 20%. When the signal into any amplitude sensor is above the 90% threshold reference, the gain setting is maintained for that track. When all tracks have set up, the counter is stopped and the highest count appears at TP 3 **2**. If, during a Read operation, the counter reaches 16 (15 for a Write operation) and any track(s) remain(s) below threshold +SAGC Check is activated.

SAGC Check causes an interrupt signal to be sent to the tape control. During a Write operation, the SAGC check is made at count 15 to provide additional gain for reading tapes with deteriorated signal output.

READ HEAD AND READ CARD CIRCUITS

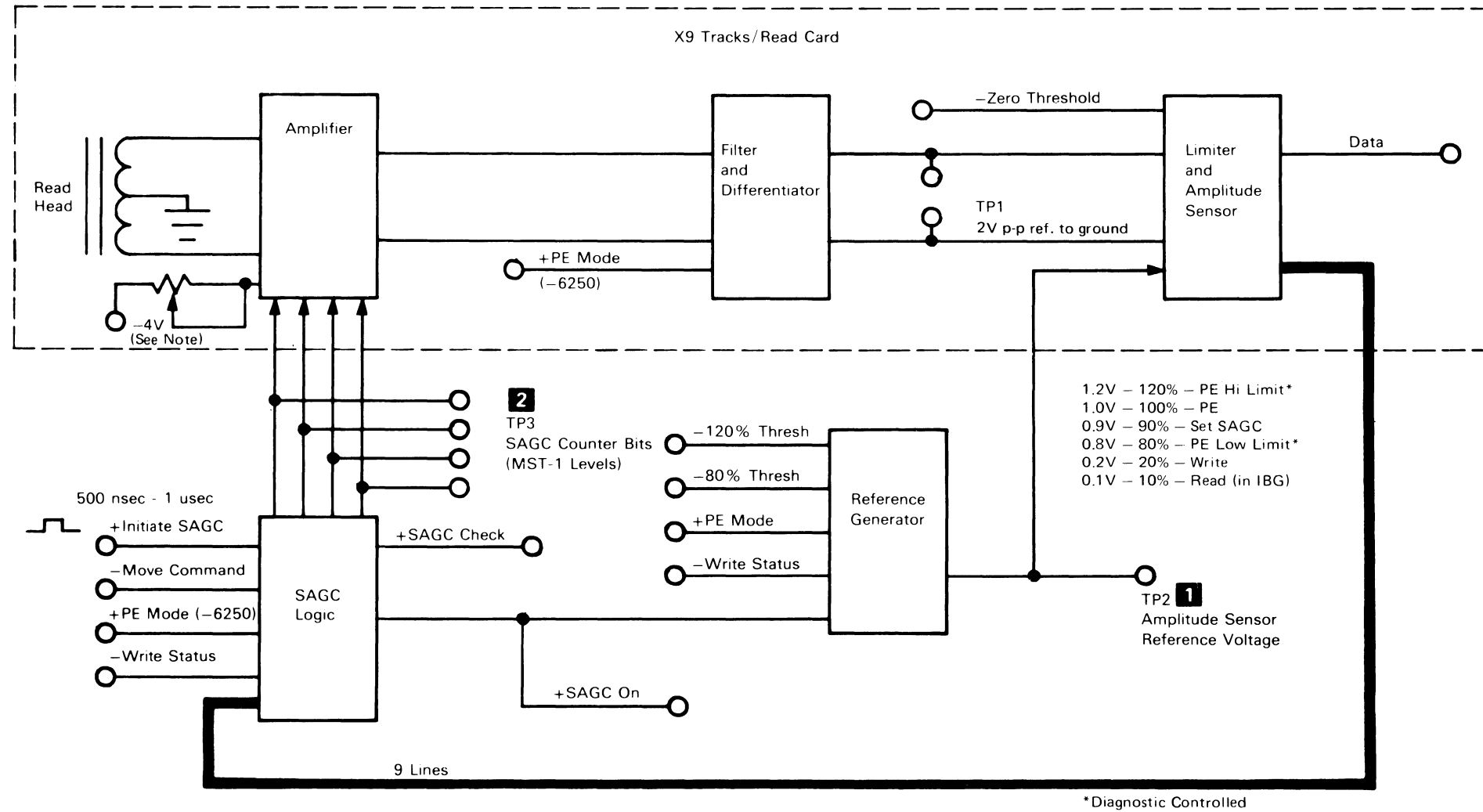

**Note:** Potentiometers are used to set amplitude in 1600 bpi mode. SAGC sets Read signal amplitude automatically in 6250 bpi mode. A 6250 bpi single density tape unit retains the track 1 potentiometer to adjust the gain for reading the ID burst.

3803-2/3420

XC2400	2735801	See EC	845958				
Seq 2 of 2	Part Number	History	1 Sep 79				

© Copyright International Business Machines Corporation 1976, 1979



To perform a Write operation, the mounted tape reel must contain a Write Enable ring. The initial tape unit status indicates whether or not this ring is present.

A write command attempts to set Write Status and resets the Backward latch in the tape unit. However, the tape unit does not return the Write Status indication unless a Write Enable ring is installed on the tape reel.

- 1 During initial selection, the tape control requests sense bytes 0 and 1 from the tape unit to determine what status to include in the initial status byte that is sent to the channel.
- A The tape control deactivates all tags to the tape unit and activates tape unit bus out (TUBO) bit 7 to request sense byte 0.
- B The tape unit transmits sense byte 0 to the tape control.
- C The tape control deactivates bit 7 and activates bit 6 to request sense byte 1.
- D The tape unit transmits sense byte 1 to the tape control.
- 2 The tape control resets the tape unit error latches by activating the Command tag and TUBO bit 6.
- 3 The tape control transmits the Write command to the tape unit by activating the Command tag and TUBO bit 4.
- 4 The tape unit transmits the command status byte to the tape control on tape unit bus in (TUBI). The tape control compares the status byte with the command and activates Command Status Reject if they do not compare.
- 5 The tape control activates Move to the tape unit. The tape control monitors Tachometer In/Busy In to ensure that the capstan started. If the tachometer did not start, the Tach Failure error is activated.

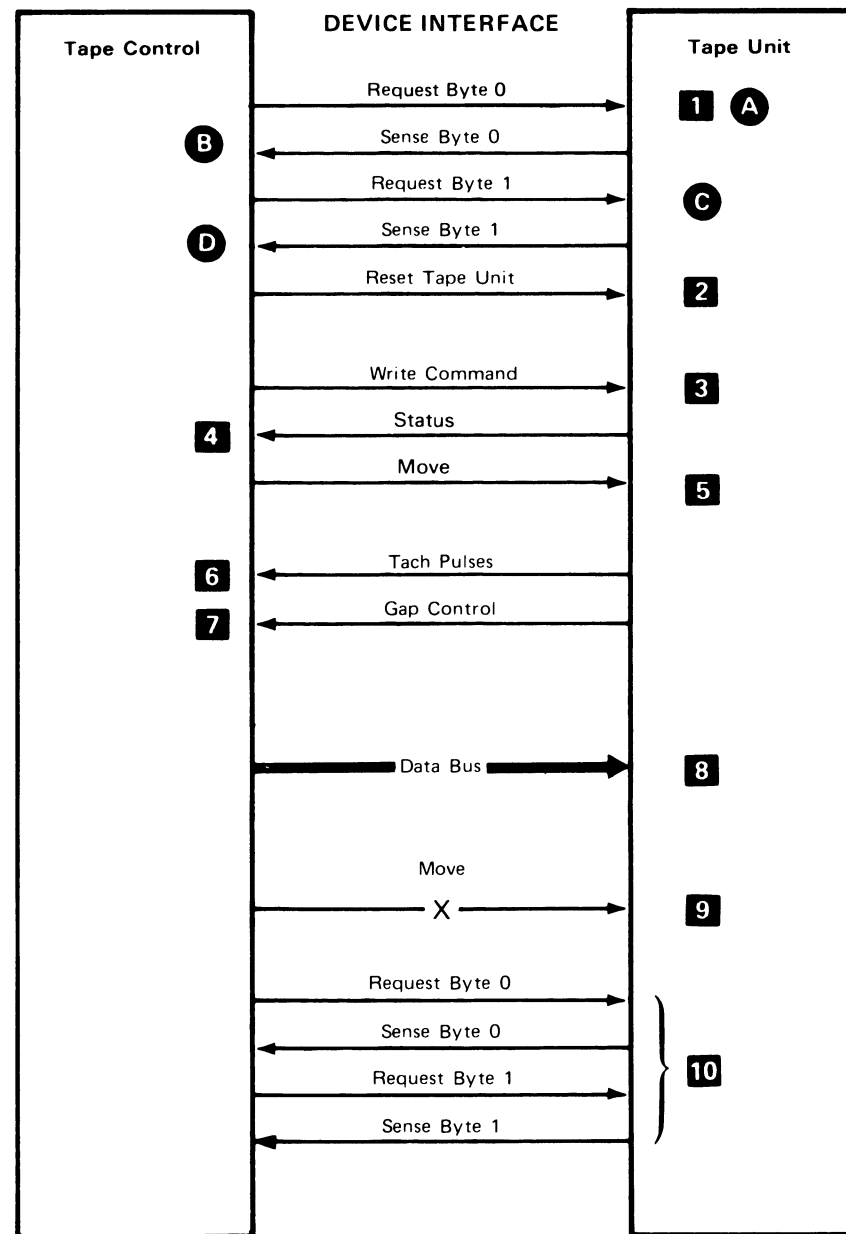

- 6 The tape unit transmits the tachometer pulses to the tape control if the operation is proceeding normally.
- 7 The tape control waits for gap control (IBG 68 for 6250 bpi or IBG 64 for 1600 bpi operations) from the tape unit. The tape control holds Command tag active until a Gap Control indication is received. The tape control then measures tape speed by measuring the time between tachometer pulses.
- 8 When tape speed is satisfactory, the tape control places data to be written on TUBO.
- 9 When all data has been written, the tape unit uses Extended Go to hold its own Go active until a specified interblock gap (IBG) count is reached. See Page 6B-205 for IBG counter operation. The tape control does not deactivate Move until the last byte has been read back.
- 10 The tape control again requests sense bytes 0 and 1 from the tape unit to determine what the status to include in the ending status byte sent to the channel. The bytes are requested and transferred in the same manner described in step 1.

READ FORWARD OPERATION

- 1 A read forward command resets the tape unit's Write Status latch and Backward latch.
- 2 When the Write Status latch is reset, the tape unit signals the tape control that it is in read status.
- 3 The tape control activates the Move tag which sets Go Internal in the tape unit and starts tape motion.
- 4 The Tach Failure Error latch is set in the tape control if no tach pulses are received.
- 5 The tape unit places data read from tape on tape unit bus in (TUBI).
- 6 After all data bytes have been read, the tape control deactivates the Move tag. The tape unit interblock gap (IBG) counter holds Extended Go active to control the position of the read head in the IBG when tape motion is stopped. See 6B-205 for IBG counter operation.
- 7 The tape control requests sense bytes 0 and 1 from the tape unit. This information is included in the ending status byte sent to the channel.

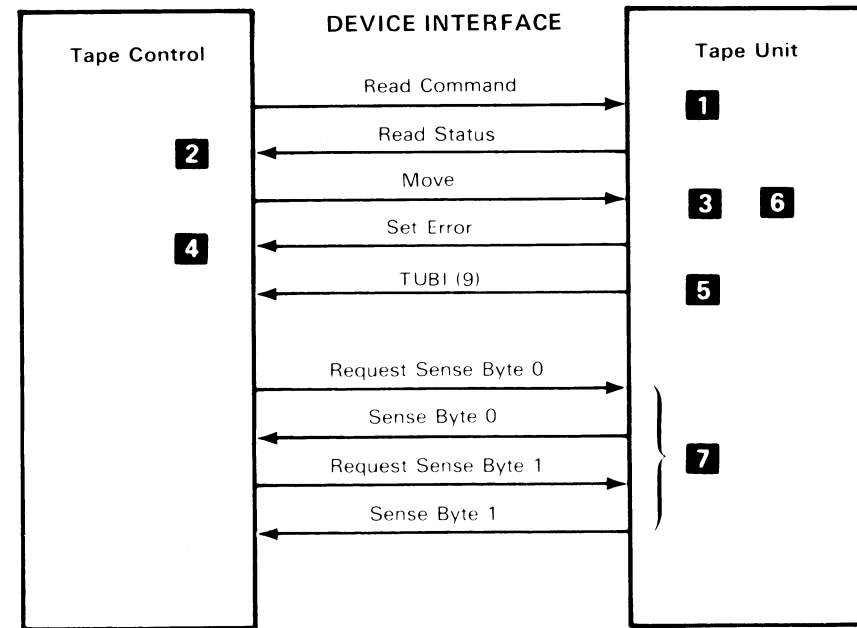

READ BACKWARD OPERATION

Read backward is similar to read forward except that tape moves backward. The Backward latch is set when the Read Backward command is issued to the tape unit.

The tape drive positions the tape properly in preparation for the next operation.

A forward movement is required prior to a Backward start if more than 12 milliseconds have elapsed since the last operation.

XC2500 Seq 2 of 2	2735802 Part Number	See EC History	845958 1 Sep 79					
----------------------	------------------------	-------------------	--------------------	--	--	--	--	--





# CAPSTAN MOTION FAILURE SYMPTOMS

6B-000

From 00-040, 2B-xxx, 3B-xxx, 4B-xxx, 5B-xxx		
<b>ERROR DESCRIPTION:</b>		
The Capstan control system may fail with the following symptoms: Refer to 6B-200 through 6B-230 for description of capstan drive circuits.		
1. Capstan runs all the time. 2. Tape does not load. 3. Fails after normal load.		
<b>Most Probable Causes:</b>		
<ul style="list-style-type: none"> <li>• Dirty/glazed capstan</li> <li>• Low air bearing pressure</li> <li>• Loose/misadjusted stubby bars</li> <li>• Tape sticking</li> <li>• Dirty R/W head</li> <li>• Capstan motor assembly</li> </ul>		
If tape motion also appears correct, you can reach this page from the Tape Control MAP. Otherwise, you will come here from 00-040 or from MAPS 2B-xxx thru 5B-xxx. <b>See note.</b>		
If intermittent tape dump is being experienced in either column, an open capstan armature may be indicated. To check the capstan armature, unplug the capstan motor cable from the capstan board and with a CE ohmmeter measure the two leads going to the capstan motor. Watch for a deflection while turning the capstan by hand very slowly. Any deflection of the meter indicates an open armature.		
<b>Always</b> start with Seq 1 and follow the procedure in sequence unless directed otherwise. <b>Remember</b> to END all problems or maintenance calls by going to MAP 00-030.		
Seq	Condition/Instruction	Action
1	With the tape unit unloaded, turn power On. Field tester should not be attached to tape unit.	
2	Does the capstan run as soon as power is turned on?	Go to Seq 16.
3	Mount a CE work tape, press RESET and LOAD REWIND.	
4	Does the tape unit thread, load, and rewind to BOT properly?	Go to 6B-020 and perform the motion tests described. Record all failing symptoms and deviations. Return to Seq 12.
5	Are dc power supply voltages out of spec? See 08-000.	Adjust voltages, change fuses, or repair power supply as required. See power supply MAP 1B-000 Seq 11 (Seq 46 for modified supply) and return to Seq 6.
6	Does the tape unit now thread, load, and rewind to BOT properly?	Go to 00-030.
7	Perform capstan tachometer checks and adjustments. See 08-120. Do not adjust if within specs.	
8	Were you unable to adjust tachometer to meet specs?	<b>DANGER:</b> <b>First turn power off and allow light bulb to cool.</b> 1. Clean light bulb with water. 2. Change light bulb. 3. Change tachometer and go to Seq 9.

Seq	Condition/Instruction	Action
9	Check digital to Analog Converter (DAC) outputs (see Figure 1). Do the tape unit setup (see Figure 2). Do any DAC outputs fail to pulse?	Change card T-A1E2 and T-A1K2 and go to Seq 10.
10	Does the tape unit now thread, load, and rewind to BOT properly?	Go to 00-030.
11	If not:	Go to 6B-100. <b>See note</b> on this page.
12	Did the tape unit pass all motion tests?	1. Run OLT tape unit tests 3420 T through Z. 2. Change A1L2. 3. Go to 00-030.
13	Perform capstan tachometer checks and adjustments. See 08-120. Do not adjust if within specs.	
13	Were you unable to adjust tachometer to meet specifications?	<b>DANGER:</b> <b>First turn power off and allow light source to cool.</b> 1. Clean light source with water. 2. Change light source. 3. Change tachometer and go to Seq 14.
14	Does the tape unit now pass all motion tests?	Go to 00-030.
15	If not:	Go to 6B-110.
16	Are dc power supply voltages out of spec? See 08-000.	Adjust voltages, change fuses, or repair power supply as required. See power supply MAP 1B-000.
17	Is the capstan now stopped when power is turned on?	Go to 00-030.
18	Is DAC voltage at the capstan motor control board TP less than 300 mv?	Change capstan motor control board and go to Seq 20.
19	Are all DAC driver bits on logic panel the same polarity (all +0.7V or all -0.7V)? See chart.	Change capstan motor control board.
20	Is the capstan now stopped when power is turned on?	Go to 00-030.
21	If not:	Go to 6B-140.

**Note:** If you have another tape unit available, interchange the E2, F2, G2, G6, H2, and K2 cards. If this fixes the problem, continue interchanging to isolate the failing FRU. If not, interchange the capstan motor control boards. (Replacement board must be from the same model tape unit).

Figure 1. Digital to Analog Converter Outputs.

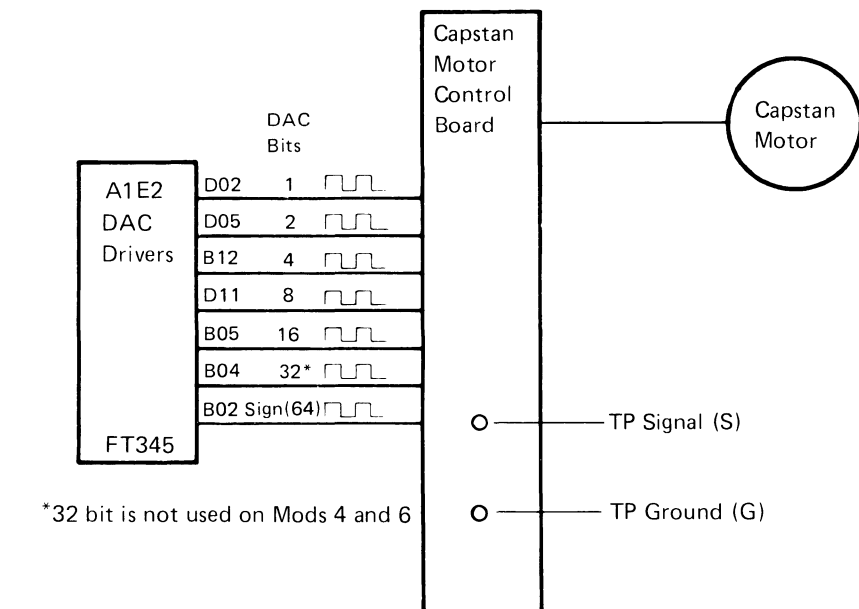

\*32 bit is not used on Mods 4 and 6

Figure 2. Tape Unit Set-up.

Uses two short strips of tape for this operation.

**Caution: Do not let tape touch the capstan under any circumstances, or the capstan may be severely damaged.**

1. Turn off tape unit power.
2. Tape a strip of magnetic tape in each column forming a loop in the middle of the column. Route the tape strip in the right column between the tape cleaner block and the erase head to keep light from hitting the BOT / EOT photocells. Route the tape strip in the left column under; the upper stubby bar to keep it away from the capstan. Cover the reels loaded port.
3. Turn on tape unit power and press LOAD REWIND. Press RESET twice, then press START.
4. Press RESET, LOAD REWIND, and START again.

3803-2/3420

XC2600	2735803	See EC History	845958	846927				
Seq 1 of 2	Part Number		1 Sep 79	20 Jun 80				

© Copyright International Business Machines Corporation 1976, 1979, 1980

6B-000

# MODEL 4—DIGITAL TO ANALOG CONVERTER WAVEFORMS

6B-010

The waveforms shown are representative only.

75 ips

**Forward Start**

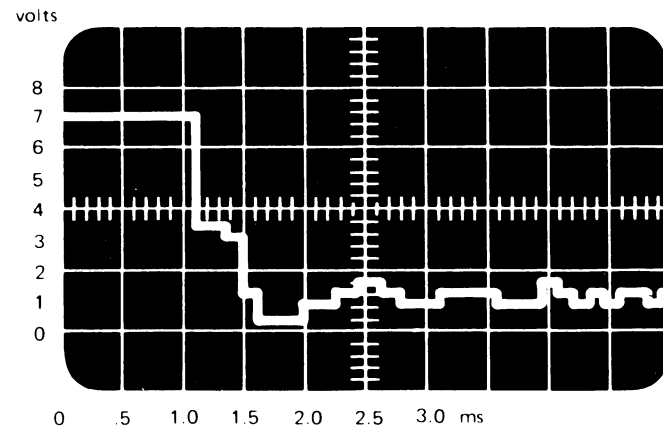

**Forward Stop**

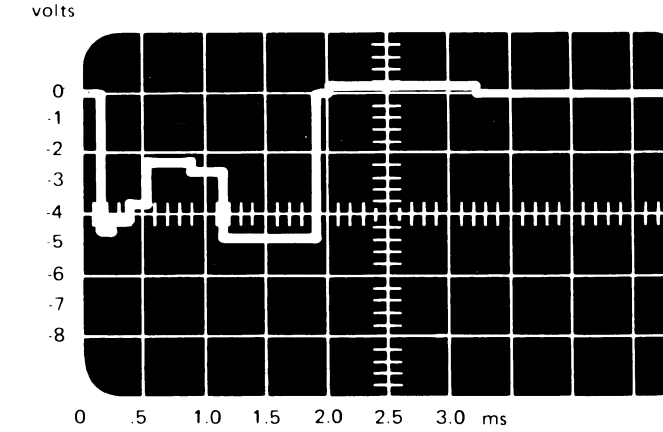

**Backward Start**

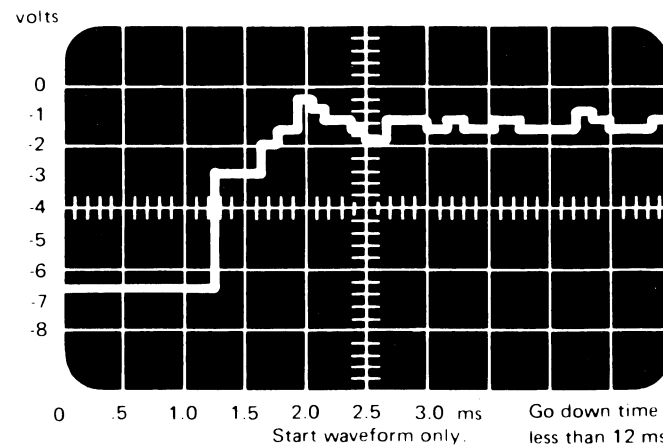

**Backward Stop**

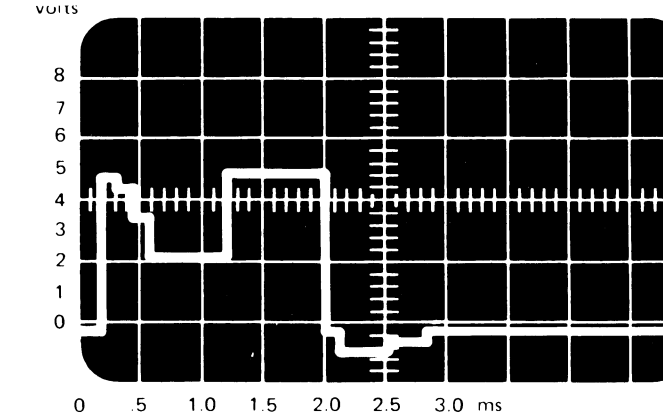

**Backward Start with Forward Hitch**

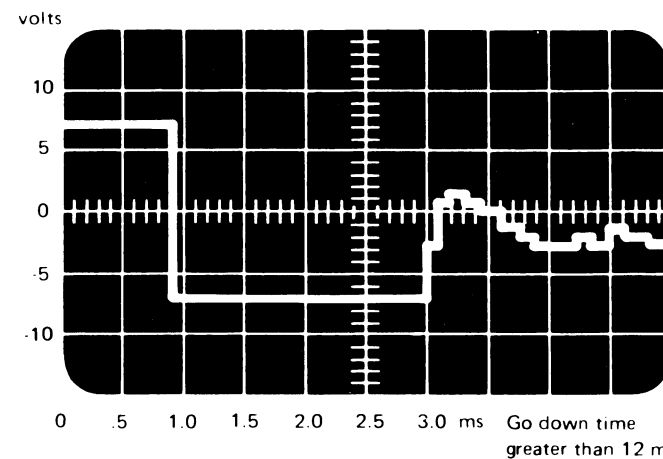

**Note:** Check timing for  $\pm 10\%$  deviation. Check voltage for  $\pm 5\%$  deviation.

3803-2/3420

XC2600	2735803	See EC	845958	846927				
Seq 2 of 2	Part Number	History	1 Sep 79	20 Jun 80				

© Copyright International Business Machines Corporation 1976, 1979, 1980

6B-010



125 ips

**Forward Start**

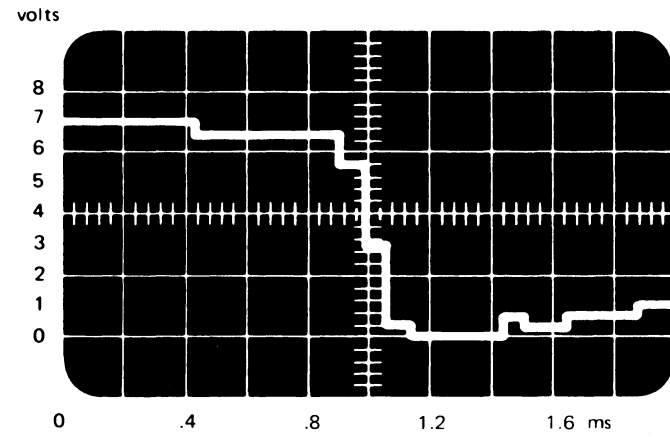

**Forward Stop**

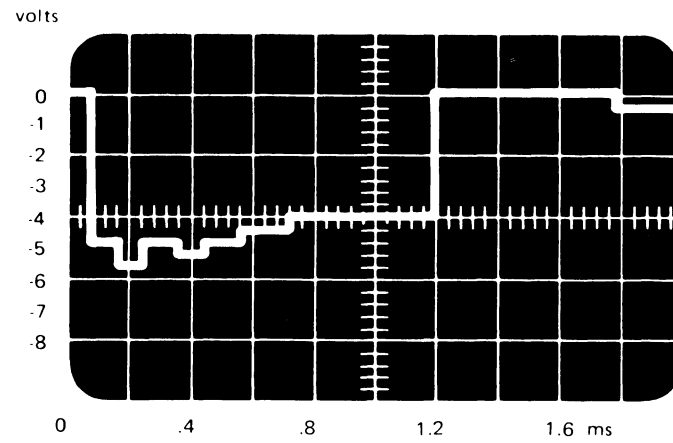

**Backward Start**

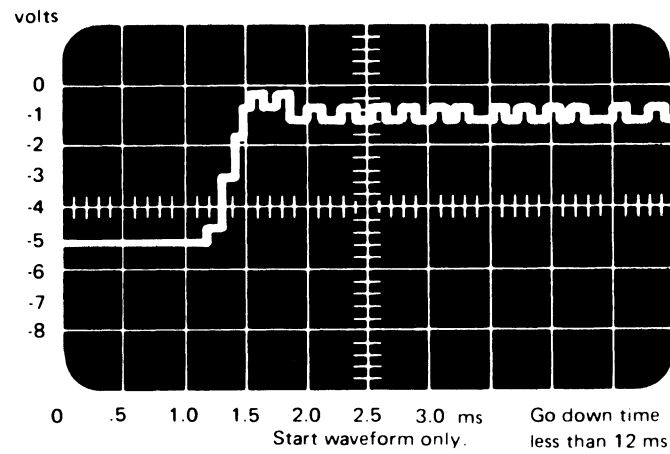

**Backward Stop**

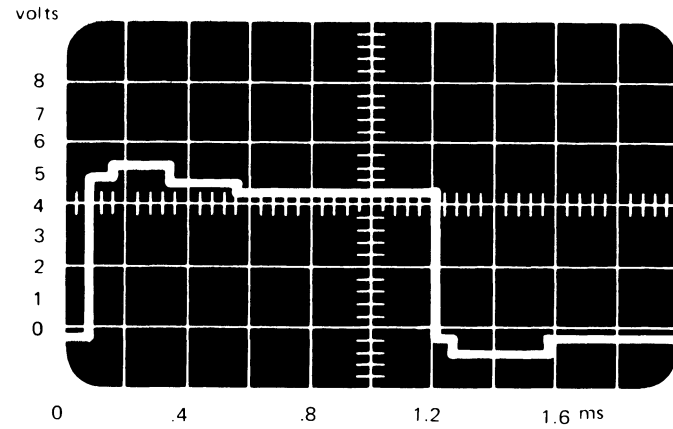

**Backward Start with Forward Hitch**

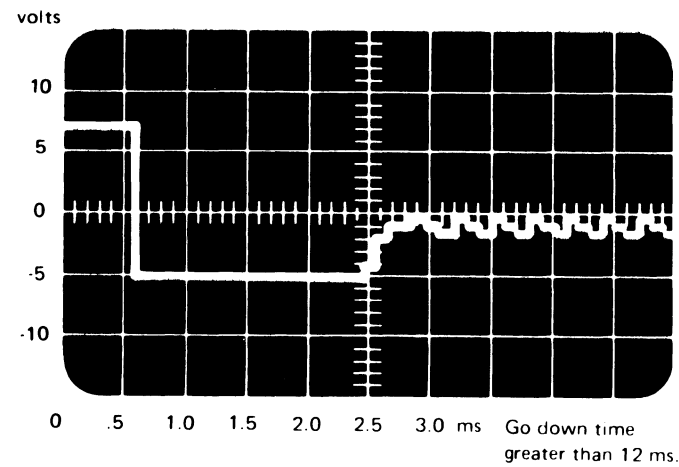

**Note:** Check timings for  $\pm 10\%$  deviation. Check Voltages for  $\pm 5\%$  deviation.

3803-2/3420

XC2700 Seq 1 of 2	2735804 Part Number	See EC History	845958 1 Sep 79					
----------------------	------------------------	-------------------	--------------------	--	--	--	--	--

200 ips

Forward Start

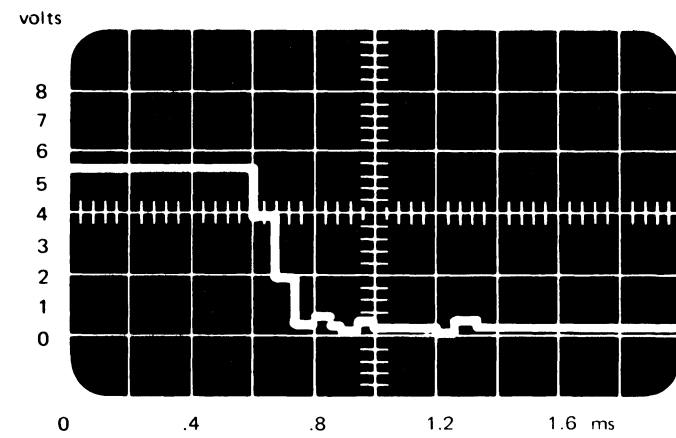

Forward Stop

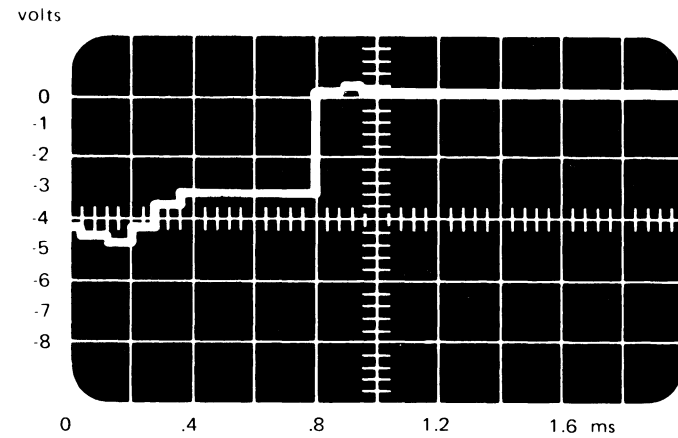

Backward Start

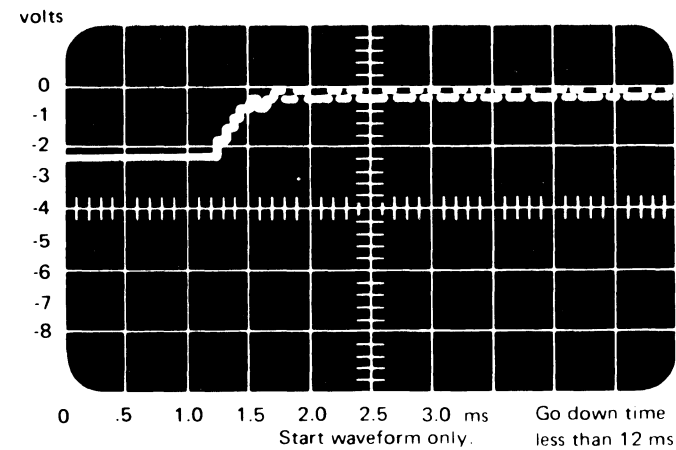

Backward Stop

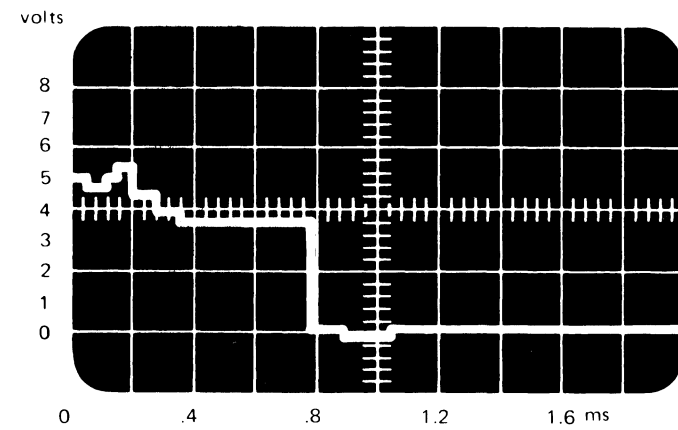

Bakward Start with Forward Hitch

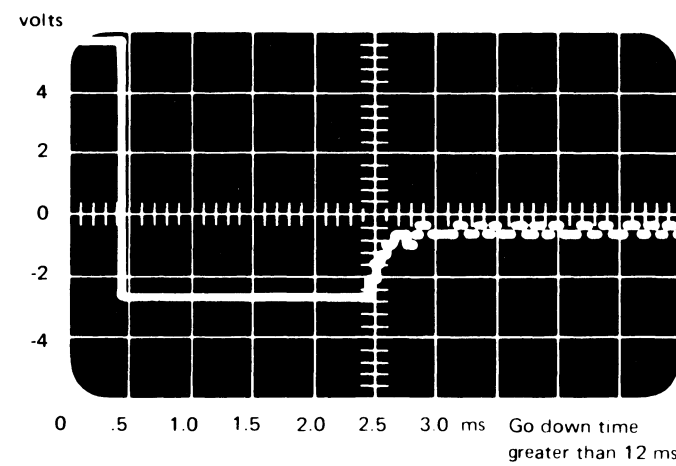

Note: Check timings for  $\pm 10\%$  deviation. Check voltages for  $\pm 5\%$  deviation.

3803-2/3420

XC2700 Seq 2 of 2	2735804 Part Number	See EC History	845958 1 Sep 79					
----------------------	------------------------	-------------------	--------------------	--	--	--	--	--

© Copyright International Business Machines Corporation 1976, 1979



# CAPSTAN MOTION CHECKS (CAPSTAN MOTION APPEARS NORMAL)

The following procedure verifies normal capstan motion. Checks 1 through 5 can be made by using a field tester and a work tape:

1. Gap Control timings
2. Tach Period timings
3. DAC (digital-to-analog converter) start voltages, waveforms, and timings
4. DAC stop voltages and timings
5. Extended Go timings

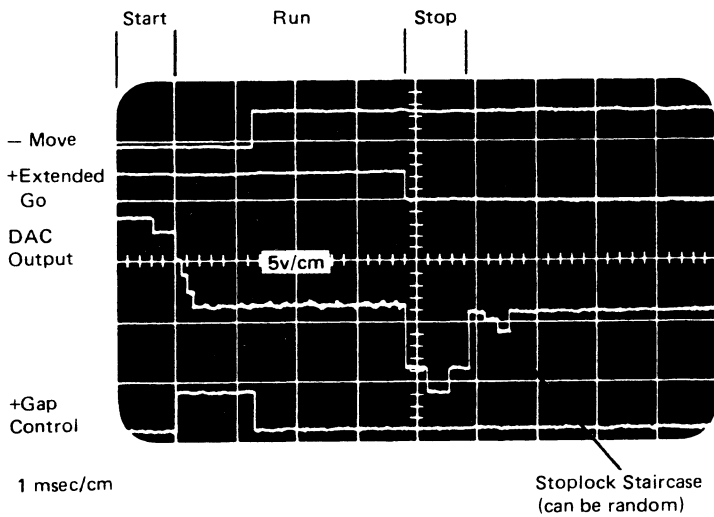

**Note:** Waveform is for Model 6. The time after gap control will vary depending on tester setup and tape unit model.

## SET UP

Mount a CE work tape.

1. Set 6250 bpi mode by adding a jumper between T-A1K2P02 and T-A1M2D06. Sync scope negative on -Move Command B (F2P12) and display +Gap Control (K6J06). Make tape unit READY and put field tester in St/Stp mode.

The timings to Gap Control (from start of Move Command B to start of Gap Control) for a Start operation are:

	FWD	BKW	BKW W/FWD Hitch
200 ips	0.6 ms	0.7 ms	2.7 ms
125 ips	0.8 ms	0.9 ms	2.9 ms
75 ips	1.1 ms	1.2 ms	3.0 ms

2. Sync scope minus internal and check the tach period timings by displaying -Phase A (T-A1H2G09) and -Phase B Gated (T-A1H2D13) with the field tester in both Forward and Backward modes (not St/Stp mode).

The nominal tach period timings with the tester in Forward and Backward modes are:

200 ips 47 usec  
 125 ips 75 usec  
 75 ips 126 usec

Tach period variations, while running in forward or backward mode (not St/Stp mode), should not exceed  $\pm 4\%$  of nominal.

3. Set field tester to St/Stp mode, sync scope negative on -Move Command B (T-A1F2P12) and display DAC output (at capstan power board test point). Check DAC start voltages, waveforms, and timings against those shown on page 6B-010, Mod 4; 6B-011, Mod 6; and 6B-012, Mod 8.

4. With field tester still in St/Stp mode, sync scope negative on +Exten and display the DAC output. (See Figure 2 for tape unit setup in preparation for measuring the DAC outputs as shown in Figure 1.) Check the DAC stop voltages and timings for minimum, maximum, and nominal values during capstan stops. Constant minimum or maximum values indicate a fault condition. See page 6B-010, Mod 4; 6B-011, Mod 6; and 6B-012, Mod 8.

Display the DAC output and check for excessive stoplock staircase, noting the number of steps, as well as the polarity. There should be 2 to 3 steps maximum. (There can be no steps, and polarity can vary.)

5. With field tester still in St/Stp mode, sync scope positive on -Move Command B (T-A1F2P12) and display +Extended Go (T-A1F2J11). 6250 bpi mode timings for Extended Go (from end of Move to end of Extended Go) are as follows:

	200 ips	125 ips	75 ips
Fwd Write	.57 ms	.91 ms	1.52 ms
Fwd Read	.49 ms	.78 ms	1.30 ms
Bkwd Read	.18 ms	.3 ms	.49 ms

(all tolerances  $\pm 4\%$ )

To check Extended Go timings in PE mode, remove the jumper from T-A1K2P02 to T-A1M2D06 and rewind tape to BOT to reset 6250 bpi mode. Leave jumper off for remainder of tests. PE mode timings for Extended Go are as follows:

	200 ips	125 ips	75 ips
Fwd Write	1.06 ms	1.69 ms	2.82 ms
Fwd Read	1.43 ms	2.29 ms	3.82 ms
Bkwd Read	1.06 ms	1.69 ms	2.82 ms

(all tolerances  $\pm 4\%$ .)

Return to Seq 12, Page 6B-000.

Figure 1. Digital to Analog Converter Outputs

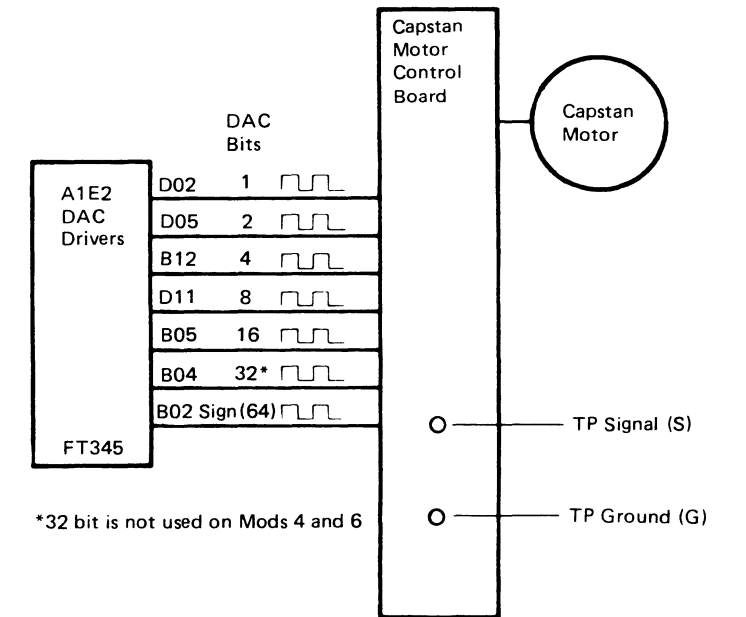

Figure 2. Tape Unit Set-Up

Use two short strips of tape for this operation.

**Caution:** Do not let tape touch the capstan under any circumstances, or the capstan may be severely damaged.

1. Turn off tape unit power.
2. Tape a strip of magnetic tape in each column forming a loop in the middle of the column. Route the tape strip in the right column between the tape cleaner block and the erase head to keep light from hitting the BOT/EOT photocells. Route the tape strip in the left column under the upper stubby bar to keep it away from the capstan. Cover the reels loaded port.
3. Turn on tape unit power and press LOAD REWIND, press RESET twice, then START. For write operation press file protect pin.
4. Press RESET, LOAD REWIND, and START again.

XC2800	2735805	See EC History	845958	847298			
Seq 1 of 2	Part Number		1 Sep 79	15 Aug 83			

# TAPE UNIT WON'T THREAD, LOAD, AND RETURN TO BOT PROPERLY

<b>From 6B-000</b>		
<p>You should have entered this page from 6B-000, Seq 11. You have checked power supply voltages and completed the tachometer and direction-sense checks. Since the tape unit will not perform a normal load, use the following procedure to set up a tape loop logic check. Use two short strips of tape for this operation.</p> <p><b>Caution: Do not let tape touch the capstan under any circumstances, or the capstan may be severely damaged.</b></p> <ol style="list-style-type: none"> <li>Turn off tape unit power.</li> <li>Tape a strip of magnetic tape in each column forming a loop in the middle of the column. Route the tape strip in the right column between the tape cleaner block and the erase head to keep light from hitting the BOT/EOT photocells. Route the tape strip in the left column under the upper stubby bar to keep it away from the capstan. Cover the reels loaded port.</li> <li>Turn on tape unit power and press LOAD REWIND. PRESS RESET twice, then press START.</li> <li>Press RESET, LOAD REWIND, and START again.</li> </ol>		
<p><b>Always</b> start with Seq 1 and follow the procedure in sequence unless directed otherwise. <b>Remember</b> to END all problems or maintenance calls by going to MAP 00-030.</p>		
Seq	Condition/Instruction	Action
1	Scope T-A1H2G09. Pulses indicate capstan motion. Is the capstan turning?	Go to Seq 21.
2	Is the DAC voltage at the capstan motor control board test point more than 300 mv?	Change the board and go to 00-030.
3	Do the DAC Driver bits on logic panel have different polarities? (All should be either +0.7v or -0.7v). See Figures 1 and 2 on 6B-000.	Change capstan motor control board and go to 00-030.
4	Is +Extended Go (T-A1F2J11) minus?	Change T-A1F2 card and go to 00-030.
5	Is -Extended Go (T-A1F2D02) plus?	Change T-A1F2 card and go to 00-030.
6	Is -Go Internal (T-A1F2U05) plus?	Change T-A1F2 card and go to 00-030.
7	Jumper T-A1F2P07 to ground. (This forces Start Current.)	
8	Is -Start Current (T-A1F2J05) plus?	Remove jumper from T-A1F2P07, change T-A1F2 card, and go to 00-030.
9	Is T-A1H2G09 pulsing?	Go to Seq 38.
10	Is -T3 (T-A1H2S10) failing to pulse?	Remove jumper from T-A1F2P07, change T-A1H2 card, and go to 00-030.
11	Is +Set PHD Reg (T-A1G2G03) pulsing?	Go to Seq 14.
12	Is -T4 (T-A1H2S12) pulsing?	Remove jumper from T-A1F2P07, change T-A1G2 card, and go to 00-030.
13	If not:	Remove jumper from T-A1F2P07, change T-A1H2 card, and go to 00-030.
14	Is +1/4 Tach Stop Sync (T-A1G2M04) plus?	Remove jumper from T-A1F2P07, change T-A1G2 card, and go to 00-030.
15	Is -Gate PDC (T-A1G2M05) plus?	Remove jumper from T-A1F2P07, change T-A1G2 card, and go to 00-030.

Seq	Condition/Instruction	Action
16	Is +Stoplock (T-A1G2P04) plus?	Remove jumper from T-A1F2P07, change T-A1G2 card, and go to 00-030.
17	Is -PDC Input (T-A1G2J02) minus?	Remove jumper from T-A1F2P07, change T-A1G2 card, and go to 00-030.
18	Is Gate PHD (T-A1G2D10) minus?	Remove jumper from T-A1F2P07, change T-A1G2 card, and go to 00-030.
19	Is -Go Internal (T-A1F2U05) plus?	Remove jumper from T-A1F2P07, change T-A1F2 card, and go to 00-030.
20	If not:	Remove jumper from T-A1F2P07, change T-A1E2 card, and go to 00-030.
21	Set oscilloscope to 1 ms/cm and scope -Backward Capstan Motion (T-A1H2M12).	
22	Is line in Seq 21 pulsing?	Go to Seq 80.
23	Is line in Seq 21 plus?	Go to Seq 71.
24	Scope -Phase A (T-A1H2G09). Period should be: Model 8 - 47 usec Model 6 - 56 usec Model 4 - 61 usec (All timings are ± 4%.)	
25	Is the backward tach period normal? (Within ±4% of nominal)	Go to Seq 51.
26	Is the backward tach period short? (More than 4% away from nominal.)	Go to Seq 32.
27	Is -Go Backward (T-A1F2P13) plus?	Change T-A1F2 card and go to 00-030.
28	Is -16 Cnt Pulse (T-A1H2P05) failing to pulse?	Change T-A1G2 card and go to 00-030.
29	If not:	Press RESET and go to Seq 30.
30	Does -16 Cnt Pulse (T-A1H2P05) stop?	Go to Seq 69.
31	If not:	Press LOAD REWIND, START and go to Seq 80.
32	Is -Start Current (T-A1F2J05) plus?	Go to Seq 35.
33	Is +Gated Opp Direction (T-A1F2P07) minus?	Change T-A1F2 card and go to 00-030.
34	Is -Extended Go (T-A1F2S02) plus?	Change T-A1F2 card and go to 00-030.
35	Is -Opp Direction (T-A1F2B02) pulsing?	Change T-A1F2 card and go to 00-030.
36	Is -Sampled TPC Equal (T-A1G6B13) failing to pulse?	Change T-A1G6 card. If not fixed, change T-A1G2 card and go to Seq 37.
37	Is +Backward Status (T-A1F2S04) plus?	Change T-A1H2 card. If not fixed, go to Seq 40.
38	Is +AT5 (T-A1H2D02) pulsing?	Go to Seq 40.
39	If not:	Change T-A1H2 card. If not fixed, go to Seq 40.

Seq	Condition/Instruction	Action
40	Is +Normal Run Pulse (T-A1H2J09) minus?	Go to Seq 43.
41	Is +Reset TPC (T-A1G2U13) failing to pulse?	Change T-A1G2 card and go to 00-030.
42	If not:	Change T-A1H2 card. If not fixed, go to Seq 45.
43	Is -Normal Run Pulse (T-A1H2P12) plus?	Go to Seq 45.
44	If not:	Change T-A1H2 card and go to 00-030.
45	Is +Reset TPC (T-A1G2U13) failing to pulse?	Change T-A1G2 card and go to 00-030.
46	Is -PDC 16 Bit (T-A1E2S10) minus?	Change T-A1E2 card and go to 00-030.
47	Is -PDC 1 Bit (T-A1E2S09) minus?	Change T-A1E2 card and go to 00-030.
48	Is -Set Nominal Stop Current (T-A1G2G02) minus?	Change T-A1G2 card and go to 00-030.
49	Is +Gate Nominal Stop Delay (T-A1G2B13) plus?	Change T-A1G2 card and go to 00-030.
50	Is +Block PDC Counting (T-A1E2D12) minus?	Change T-A1E2 card. If not fixed, go to Seq 51.
51	Is +Stoplock Not Hitch Active (T-A1H2B13) minus?	Change T-A1G6 card and go to 00-030.
52	Reserved	
53	Is -T3 (T-A1H2S10) failing to pulse?	Change T-A1H2 card and go to 00-030.
54	Is +T5 (T-A1H2U13) failing to pulse?	Change T-A1H2 card and go to 00-030.
55	Is +2 KHz osc. (T-A1H2D04) pulsing?	Go to Seq 57.
56	If not:	Change T-A1H2 card and go to 00-030.
57	Is +Set Error Hitch (T-A1H2M09) minus?	Go to Seq 59.
58	If not:	Change T-A1H2 card and go to 00-030.
59	Is -1 Bit DAC (T-A1E2D02) failing to pulse?	Change T-A1E2 card and go to 00-030.
60	Is +IBG 68 Count (T-A1F2D02) plus?	Change T-A1F2 card and go to 00-030.
61	Is -PDC 16 Bit (T-A1E2S10) failing to pulse?	Change T-A1E2 card and go to 00-030.
62	Is -PDC 8 Bit (T-A1E2U13) failing to pulse?	Change T-A1E2 card and go to 00-030.
63	Is -2 Bit DAC (T-A1E2D05) failing to pulse?	Change T-A1E2 card and go to 00-030.
64	Is -PDC 4 Bit (T-A1E2U10) failing to pulse?	Change T-A1E2 card and go to 00-030.

3803-2/3420

XC2800 Seq 2 of 2	2735805 Part Number	See EC History	845958 1 Sep 79	847298 15 Aug 83				
----------------------	------------------------	-------------------	--------------------	---------------------	--	--	--	--

**TAPE UNIT WON'T THREAD, LOAD, AND RETURN TO BOT PROPERLY  
(Cont'd)**

**6B-101**

Seq	Condition/Instruction	Action
65	Is +Go Internal (T-A1F2S07) minus?	Change T-A1F2 card and go to 00-030.
66	Is -IBG 28 Count (T-A1F2P02) minus?	Change T-A1F2 card and go to 00-030.
67	Is +Set Fwd Hitch Reg (T-A1G6J13) minus?	Change T-A1G2 card and go to 00-030.
68	If not:	Change T-A1G6 card and go to 00-030.
69	Is +T5 (T-A1H2U13) pulsing?	Change T-A1G2 card and go to 00-030.
70	If not:	Change T-A1H2 card and go to 00-030.
71	Scope the following points: -T0            T-A1H2S07 +T1            T-A1H2U05 -T2            T-A1H2S09 -T3            T-A1H2S10 -T4            T-A1H2S12 +T5            T-A1H2U13	T pulses are 167 ns for Models 4 and 6; 83 ns for Model 8.
72	Are any pulses bad?	Change T-A1H2 card and go to 00-030.
73	Is Transition T1-T4 (T-A1H2J04) failing to pulse?	Change T-A1H2 card and go to 00-030.
74	Is -Forward Drive (T-A1F2J02) minus?	Change T-A1F2 card and go to 00-030.
75	Is +1/4 Tach Stop Sync (T-A1G2M04) plus?	Change T-A1G2 card and go to 00-030.
76	Is -Set PDC (T-A1G2J05) plus?	Change T-A1G2 card and go to 00-030.
77	Is -PDC Input (T-A1G2J02) minus?	Change T-A1G2 card and go to 00-030.
78	Is -PDC Sign Bit (T-A1E2U12) plus?	Change T-A1E2 card and go to 00-030.
79	If not:	Change T-A1H2 card and go to 00-030.
80	Scope the following points: -T0            T-A1H2S07 +T1            T-A1H2U05 -T2            T-A1H2S09 -T3            T-A1H2S10 -T4            T-A1H2S12 +T5            T-A1H2U13	T pulses are 167 ns for Models 4 and 6; 83 ns for Model 8.
81	Are any pulses bad?	Change T-A1H2 card and go to 00-030.
82	Is +AT5 (T-A1H2D02) failing to pulse?	Change T-A1H2 card and go to 00-030.
83	Is -Transition T1-T4 (T-A1H2J04) failing to pulse?	Change T-A1H2 card and go to 00-030.
84	Is +Set Stoplock 2 (T-A1H2M06) plus?	Change T-A1H2 card and go to 00-030.
85	Is +Extended Go (T-A1F2J11) minus?	Change T-A1F2 card and go to 00-030.
86	Is +Stoplock (T-A1G2P04) plus?	Change T-A1G2 and go to 00-030.
87	Is +Reset TPC (T-A1G2U13) failing to pulse?	Change T-A1G2 card. If not fixed, change T-A1G6 card and go to Seq 88.

Seq	Condition/Instruction	Action
88	Is +Sampled TPC Equal Gated (T-A1G2D12) plus?	Change T-A1G2 card and go to 00-030.
89	Is -Stop (T-A1G2J10) minus?	Change T-A1G2 card and go to 00-030.
90	Is -Sampled TPC Equal (T-A1G6B13) failing to pulse?	Change T-A1G6 card and go to 00-030.
91	Is -PDC Input (T-A1G2J02) failing to pulse?	Change T-A1G2 card and go to 00-030.
92	Is +Incr PDC (T-A1G2G13) plus?	Change T-A1G2 card and go to 00-030.
93	Is -Set PDC (T-A1G2J05) failing to pulse?	Change T-A1G2 card and to to 00-030.
94	If not:	Change T-A1E2 card and go to 00-030.

3803-2/3420

XC2900 Seq 1 of 2	2735806 Part Number	See EC History	845958 1 Sep 79				
----------------------	------------------------	-------------------	--------------------	--	--	--	--

**6B-101**

From 6B-000		
You reached this page from 6B-000. The tape unit can perform a normal thread-load sequence. There is a capstan motion check, a tachometer check, and a direction-sense check. The first sequences on this page ask questions about the motion tests, then direct you to the proper entry sequence, depending upon the symptom(s) observed.		
<b>Field Set Up:</b> Tester plugged in, and in St/Stp mode; and tape unit READY.		
<b>Always</b> start with Seq 1 and follow the procedure in sequence unless directed otherwise. <b>Remember</b> to END all problems or maintenance calls by going to MAP 00-030.		
Seq	Condition/Instruction	Action
1	Read Seqs 2, 3, and 4. Do you have more than one failure?	Go to Seq 6.
2	Is the tach period bad (more than 4% from normal)?	Change T-A1H2 card.
3	Is the backward gap control timing bad?	Go to Seq 8.
4	Is the DAC waveform bad (see 6B-010)?	Go to Seq 11.
5	If not:	Go to 00-030.
6	Do the results of your motion checks match Figure 1?	Perform action per Figure 1.
7	If not:	Go to 00-030.
8	Is -Opposite Direction (T-A1H2B02) failing to pulse?	Change T-A1H2 card.
9	Is -0E PDC 16 Bit-PDC Sign Bit (T-A1E2P07) failing to pulse?	Change T-A1E2 card.
10	If not:	Change T-A1G6 card.
11	Is -49 Count Latch (T-A1F2M05) failing to pulse?	Change T-A1F2 card.
12	Is +Stop 1 Delay (T-A1G2S08) failing to pulse?	Change T-A1G2 card
13	Is +1/4 Tach Stop Sync (T-A1G2M04) failing to pulse (200 usec pulse)?	Change T-A1G2 card.
14	Is -Gate PDC (T-A1G2M05) failing to pulse?	Change T-A1G2 card.
15	Is -Set Nominal Stop (T-A1G2G02) failing to pulse?	Change T-A1G2 card.
16	Is -2 Bit DAC (T-A1E2D05) failing to pulse?	Change T-A1E2 card.
17	Is +16 Bit DAC (T-A1E2D05) failing to pulse?	Change T-A1E2 card.
18	If not:	Change T-A1F2 card.
19	Is +T1 (T-A1H2U05) failing to pulse?	Change T-A1H2 card.
20	Is +T5 (T-A1H2U13) failing to pulse?	Change T-A1H2 card.
21	Is +Block PDC Counting (T-A1E2D12) failing to pulse?	Change T-A1E2 card.
22	If not:	Change T-A1F2 card.

Seq	Condition/Instruction	Action
23	Is -PDC 32 Bit (T-A1E2S13) failing to pulse?	Change T-A1E2 card.
24	Is -Gate Stoplock CTR (T-A1G2G12) failing to pulse?	Change T-A1G2 card.
25	Is +Complement (T-A1E2P05) failing to pulse?	Change T-A1E2 card.
26	Is +Reset TPC (T-A1G2U13) failing to pulse?	Change T-A1G2 card.
27	Is -Gate Normal Run (T-A1F2J12) failing to pulse?	Change T-A1F2 card.
28	Is +Sampled TPC Equal Gated (T-A1G2D12) failing to pulse?	Change T-A1G2 card.
29	If not:	Change T-A1H2 card.
30	Is +T1 (T-A1H2U05) failing to pulse?	Change T-A1H2 card.
31	Is -IBG 1 or 2 Bit (T-A1F2G09) failing to pulse?	Change T-A1F2 card.
32	Is -49 Count Latch (T-A1F2M05) failing to pulse?	Change T-A1F2 card.
33	Is +IBG 28 & Stop (T-A1G2P13) failing to pulse?	Change T-A1G2 card.
34	Is -T3 (T-A1H2S10) failing to pulse?	Change T-A1H2 card.
35	If not:	Change T-A1E2 card.

Seq	Condition/Instruction	Action
36	Is +Not Stop Complement (T-A1G2G04) failing to pulse?	Change T-A1G2 card.
37	Is -0E PDC 16 Bit-PDC Sign Bit (T-A1E2P07) failing to pulse?	Change T-A1E2 card.
38	If not:	Change T-A1G6 card.
39	Is +Incr PDC (T-A1G2G13) failing to pulse?	Change T-A1G2 card.
40	If not:	Change T-A1E2 card.

**Figure 1. Motion Check Matrix**

Match your symptoms (1-7) with the Xs in the matrix. Exit the bottom of the matrix and take the indicated action.

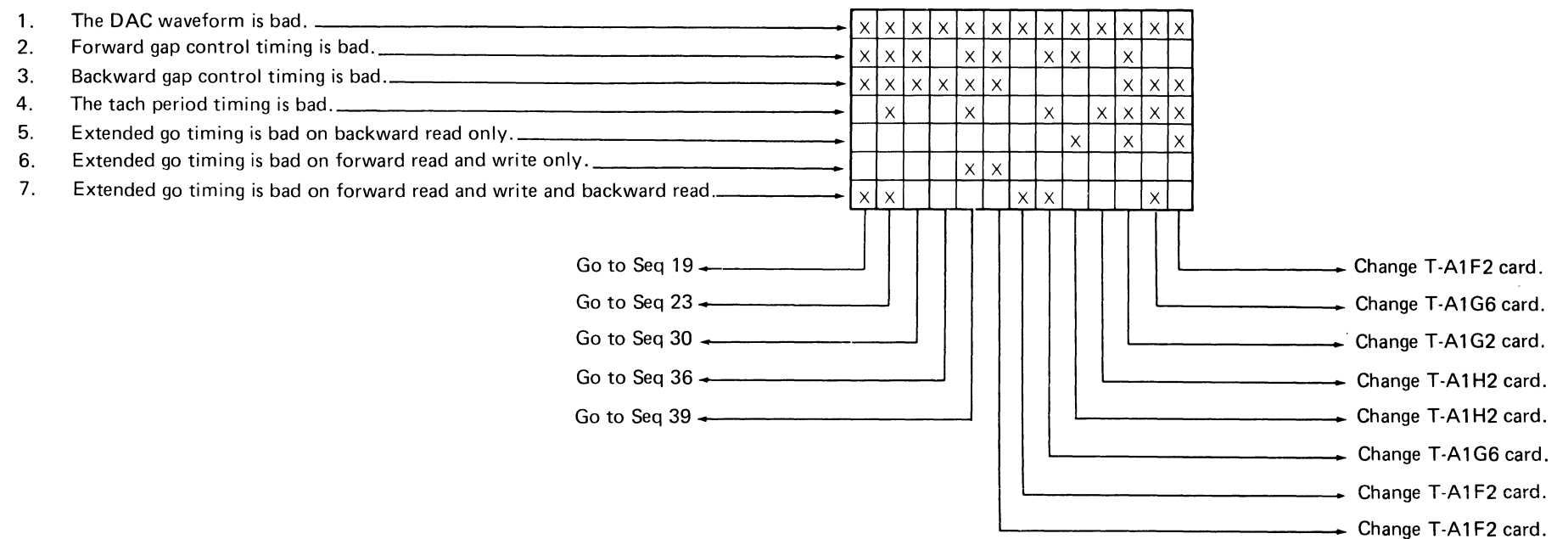

3803-2/3420							
XC2900	2735806	See EC	845958				
Seq 2 of 2	Part Number	History	1 Sep 79				



# CAPSTAN STARTS TURNING WHEN POWER IS TURNED ON

6B-140

Setup:

1. Turn power on.
2. **Do not** install field tester, or load a tape.

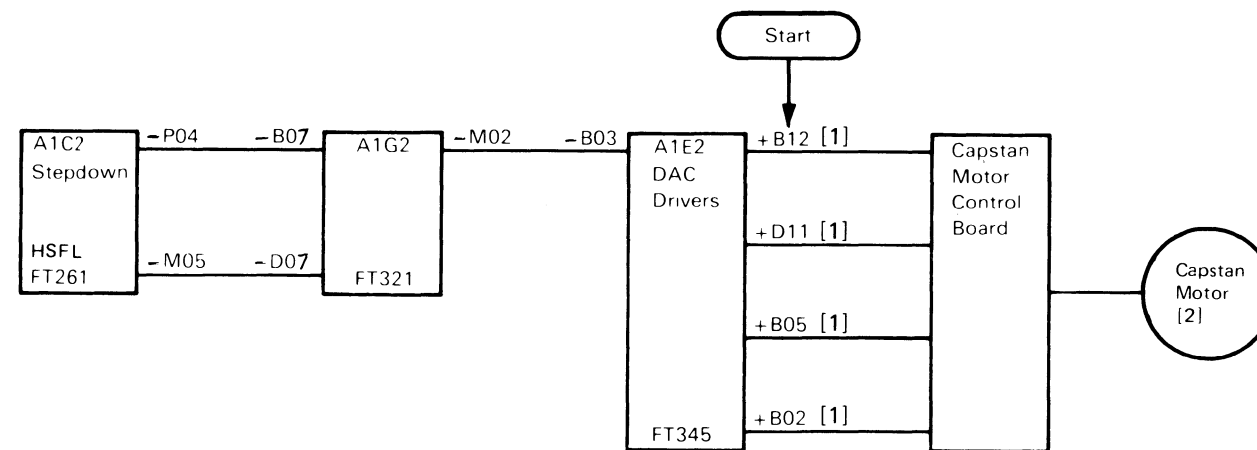

**Notes:**

- + Indicates nominal MST-1 plus (up) level of  $-0.85$  Vdc; line should have solid up level or go to the up level.
- Indicates nominal MST-1 minus (down) level of  $-1.85$  Vdc; line should have solid down level or go to the down level.

[1] Special voltages level:  $+0.7$  Vdc to  $-0.7$  Vdc.

[2] Refer to 08-000 for Capstan Motor Replacement.

3803-2/3420

XC3000 Seq 1 of 2	2735807 Part Number	See EC History	845958 1 Sep 79	846927 20 Jun 80				
----------------------	------------------------	-------------------	--------------------	---------------------	--	--	--	--

© Copyright International Business Machines Corporation 1976, 1979, 1980

6B-140

The tape loops in the stubby columns are normally in the position shown in Figure 1 while loaded and not moving or continuously moving forward or backward, or with the tester set up for Alt Dir with a long Go Up Time. Any variation in loop position beyond approximately 1/2 inch (12.7 mm) indicates a pneumatic or tape drag problem. This condition can cause intermittent read/write errors or loading problems. The figures on this page provide a visual means to help identify abnormal tape motion and to associate the symptoms to failing components.

**PROCEDURE TO CHECK FOR PNEUMATIC IMBALANCE OR LEAKS**

- A. Remove vacuum column door resonator cover (models 6 and 8 only).
- B. Load tape unit with a CE scratch tape and as soon as the tape enters the columns push reset. If the tape is positioned like Figure 1 go to step B otherwise go to probable causes below.
- C. Use Field Tester and move tape well into a high speed area.
- D. While observing the stubby columns, rewind tape unit making sure the tape goes into a high speed rewind.
- E. Tape should be equally into the right and left stubby column in both a high and low speed rewind. See Figure 1.
- F. Observe tape in stubby columns as the tape unit goes from a high to a low speed rewind. Tape must not pull out of the stubby columns. See Figure 3.
- G. If tape is not equal or pulls out of a stubby column, a problem exists which could cause intermittent read or write problems.

**Probable Causes**

1. Hoses kinked or not tight on the transfer valve or plenum.
2. Capstan-to-stubby clearance to great. It should be 0.006 to 0.010 inch (0.15 to 0.25 mm). See 08-080.

3. Vacuum column door glass to low causing a poor seal between glass and upper stubby bar. Push glass upward and check to see if tape positions itself properly. See Figure 1. Do adjustments on pages 08-690.
4. Vacuum column door maladjusted. Apply pressure to glass in the stubby column area and see if tape positions itself like Figure 1. Do adjustment on page 08-680.
5. Vacuum column door glass warped causing a poor seal between glass and stubby columns. If tape is unequal in the stubby columns, apply pressure to the glass in the area of the stubby columns and see if the tape pulls into the column as shown in Figure 1. If this is the indication and all other adjustments have been done, obtain a long straight edge (18 inch minimum) and check for warpage by holding the straight edge on the inside of the glass in the area of the stubby columns. Replace the glass if the gap between the glass and the straight edge is greater than 0.005 inches (0.13 mm).

**PROCEDURE TO CHECK FOR TAPE DRAG**

- A. Set up Field Tester as follows:  
 GO  
 ALT DIR  
 SLOW  
 READ  
 Put both potentiometers fully on (toward rear of tester).
- B. Observe the stubby columns and compare observation to figures. If stubby columns do not appear similar to Figure 1, refer to probable causes under figure most like actual observation.

**Figure 1. Normal**

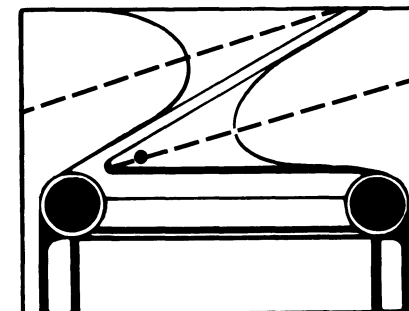

Figure 1 shows the normal position in the stubby columns. The tape should be in this position after the tape enters the columns on a load and it should maintain approximately this position during tape motion. A difference of 1/2 inch (12.7 mm) between forward and backward is normal. Measure this difference along an imaginary line referred to in Figure 1 by the dotted line.

**Figure 2. Forward Continuous**

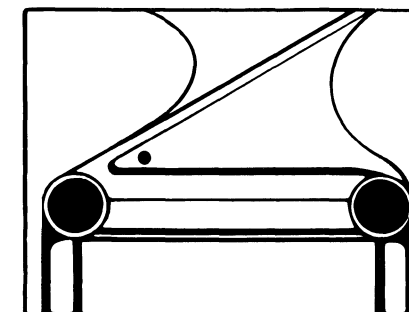

Figure 2 indicates a dirty (plugged) right air bearing, low air bearing pressure, high vacuum, or improper vacuum door glass to column seal.

**Figure 3. Backward Continuous**

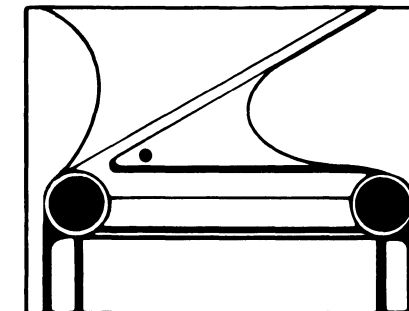

Figure 3 indicates a dirty (plugged) left air bearing, low air bearing pressure, high vacuum, or improper vacuum door glass to column seal.

**Figure 4. Forward Continuous**

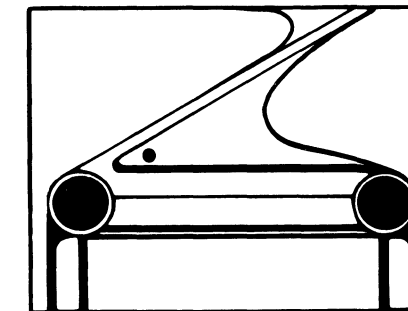

Figure 4 indicates a dirty (plugged) left air bearing or worn left stubby column glass bead tape.

**Figure 5. HS Rewind**

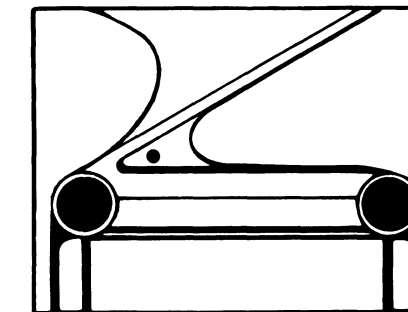

Figure 5 indicates a dirty (plugged) right air bearing or worn right stubby column glass bead tape.

3803-2/3420

XC3000	2735807	See EC	845958	846927				
Seq 2 of 2	Part Number	History	1 Sep 79	20 Jun 80				

© Copyright International Business Machines Corporation 1976, 1979, 1980

# CAPSTAN DRIVE SYSTEM

The capstan drive system moves tape past the read/write head. A constant speed is maintained while reading and writing and during slow speed rewind. The capstan speed follows the speed of the slowest reel during high speed rewind.

## CAPSTAN CONTROL CIRCUITS

- 6-MHz oscillator (osc) and gray code counter generate clock timing pulses T0 through T5.
- Capstan control logic compares capstan pulses and gray code counter pulses to generate digital correction signals which go to the Digital to Analog Converter (DAC).
- Power-on Reset blocks drive current to the motor to prevent the capstan from turning until all power supplies are at their specified voltages.

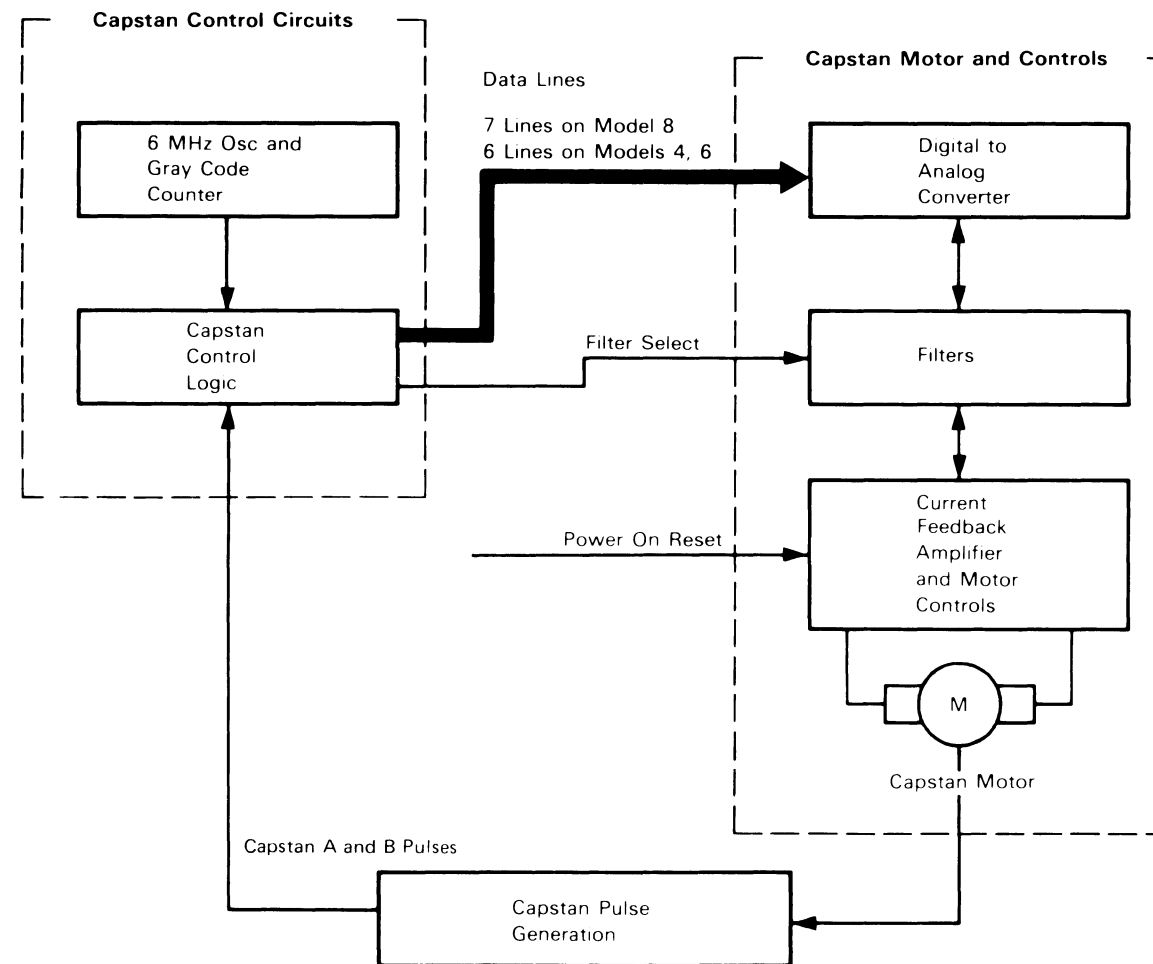

## CAPSTAN MOTOR AND CONTROLS

- The DAC takes digital logic signals from the polarity hold drive (PHD) and converts them to a voltage waveform which controls the current to the capstan motor.
- Filters shape the DAC output to achieve capstan acceleration without mechanical vibration.
- Stoplock is the ability to control the capstan motor in a fixed position by monitoring capstan tachometer phase A and B pulses.
- Power transistors control the magnitude of armature current.
- The capstan motor is a high-torque, low-inertia, vacuum-cooled dc motor which can start and stop quickly.
- The capstan motor has a permanent magnet field.
- A single, rubber-coated capstan moves tape in either direction.
- Model 8 tape unit has vacuum applied to the capstan.
- The polarity (direction) of armature current determines capstan motor direction.
- Varying the armature current controls the capstan motor speed.
- Capstan motor braking is accomplished by applying reversed drive current. This action is called plugging.

## CAPSTAN PULSE GENERATION

- The capstan turns, generating electrical impulses called capstan tach pulses.
- For Models 4 and 6, the capstan tachometer has a fiber optic light source, an etched mirror on the capstan disk face, an interrupter mask, a phototransistor, and capstan tach pulse squaring circuits.
- For Model 8, the capstan tachometer has a fiber optic light source, a see-through capstan disk, an interrupter mask, two phototransistors, and capstan tach pulse squaring circuits.
- Phase B leads Phase A by 90 degrees when tape is moving forward. Phase A leads Phase B by 90 degrees when tape is moving backward.

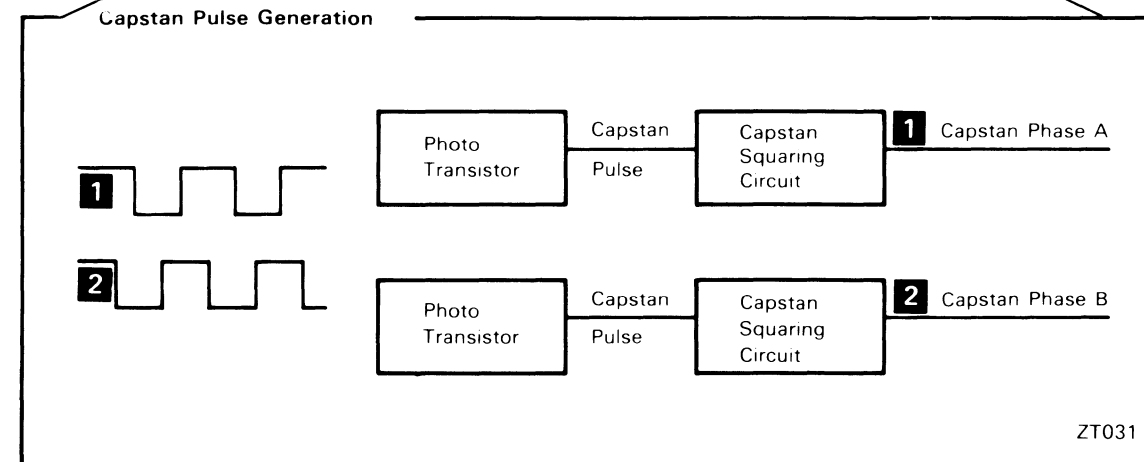

3803-2/3420

XC3100	2735808	See EC History	845958					
Seq 1 of 2	Part Number		1 Sep 79					

1. 6-MHz oscillator and gray code counter (GCC) ALD FT301.
2. Tach Period Counter (TPC) ALD FT312.
3. Proportional Drive Counter (PDC) ALD FT342.
4. Interblock Gap (IBG) Counter ALD FT332.
5. Polarity Hold Drive (PHD) Register ALD FT344.
6. Read Only Store (ROS) ALD FT313.

1. **6-MHz Oscillator and GCC**

The gray code counter (GCC) is driven by the 6-MHz oscillator furnishing six clock pulses (T0-T5) used by capstan control logic to control capstan velocity.

The pulses have a width of 83 ns on Model 8 (167 ns on Models 4 and 6) and a frequency of 2 MHz on Model 8 (1 MHz on Models 4 and 6).

2. **Tach Period Counter (TPC)**

The TPC counts T1 pulses from the gray code counter and generates a constant time-base or reference for velocity control. The TPC begins counting on a tach pulse and stops after the correct decode has been reached, generating Sampled TPC Equal.

The TPC is also used to generate a 12 millisecond reference period beginning with Stoplock to determine the need for a Forward Hitch operation after stop. The TPC provides the 768 millisecond count pulse for reel stability, reset reel fast and load point (LP) delay.

3. **Proportional Drive Counter (PDC)**

This counter has two functions:

- a. When starting, moving, and stopping tape, the counter generates a linear error count for velocity control. This count is generated by measuring the difference between the desired tach period and the actual tach period. When the TPC and decode logic generate Sampled TPC Equal, the PDC counter begins counting T1 pulses from a previously preset count. Each count represents a motor current command, which is sent to the motor via the polarity hold drive (PHD) and digital to analog converter (DAC) when the next tach pulse arrives.
- b. The PDC is used to keep track of capstan position in the IBG during Stoplock. Here, the input to the counter is quarter tach pulses, and the output count represents a current command (magnitude and polarity) which is continuously sent to the motor during positioning.

4. **IBG Counter**

The IBG counter is an eight-stage binary counter. During thread operations the IBG counter monitors progress of the operation by counting machine reel revolutions.

During 1600 bpi and 6250 bpi Read/Write operations the IBG counter monitors the length of the interblock gaps. In this application the counter is stepped by quarter tach pulses. It controls Extended GO distances (see Note).

The IBG counter also controls deceleration, distance to gap control, and forward hitch distances.

**Note: EXTENDED GO**

The tape unit Go Holdover line determines when tape stops. Go Holdover holds Extended Go active in the tape unit after the tape control has deactivated Move (6250 bpi Read, 1600 bpi Read and Write, or after the last 6250 bpi Write byte). Extended Go, stop, and start distances together determine the interblock gap (IBG).

The IBG count at which Extended Go drops varies as shown in the following table:

**Go Extensions in Quarter Tach Pulses**

	Write	Read	Read Backward
All Models 6250 bpi	49	42	16
All Models 1600 bpi	90	122	90

Additional stopping distances after Extended Go for all models equals 36 quarter tach pulses.

5. **Polarity Hold Drive (PHD) Register**

The PHD register is located in the logic flow between the PDC and the DAC. This register holds the counts of the PDC between successive full tach transitions (velocity control) or quarter tach transitions (stoplock). The counts, which represent motor correction currents, are sent continuously to the motor via the DAC.

6. **Read Only Store (ROS)**

The ROS controls deceleration. Stored within the ROS are the nominal tach periods which should occur during deceleration from nominal speed to stopped position. During deceleration the TPC count is compared to the stored ROS value (for each tach period) in order to generate a Sampled TPC Equal. When Sampled TPC Equal occurs, the PDC begins counting T1 pulses from a preset value until the next full tach transition arrives. The PDC count is then sampled to the PHD.

The IBG counter and decodes are used to access each successive ROS value during deceleration. Near the end of the stop, two time delays Stop Delay 1 and Stop Delay 2 are also provided by the ROS.

XC3100 Seq 2 of 2	2735808 Part Number	See EC History	845958 1 Sep 79					
----------------------	------------------------	-------------------	--------------------	--	--	--	--	--



# IBG GENERATION (6250 bpi)

When Move drops, the interblock gap (IBG) counter is reset. It then starts counting gated capstan quarter tach pulses continuously throughout the IBG.

The final portion of the IBG is generated at the start of the next Write operation.

Before the next block can be written, the tape must be up to speed. The IBG count continues until IBG 68. At this time Gap Control is activated, the IBG counter is reset, and the tape control begins to monitor full tach periods at half tach intervals. The tape control waits one tach period and then checks velocity. If the tape is not up to speed, the tape continues to move and velocity is tested again at each half tach period until 30 retries, the tape control activates Velocity Check and terminates the Write operation.

## IBG GENERATION (6250 BPI) SEQUENCE

1. Deactivate Write Condition and Move 10 data bit periods after the fall of Write Data.
2. Step the IBG counter with capstan quarter tach pulses when Move drops.
3. Hold Extended Go active until IBG count 49. The IBG Counter is reset at count 49.
4. Tape is stopped at IBG count 36.
5. Activating Move at the start of the next Write operation starts tape motion and continues stepping the IBG counter.
6. To signal the tape control that the tape unit is up to speed, activate Gap Control at IBG count 68 and generate TUBI bit 1, if Command tag is active.
7. The tape control monitors full tach periods at half tach intervals. After Gap Control is active, the tape control is active, the tape control waits 1 tach period and begins velocity check on the next tach period. If velocity is correct, the tape control sets Write Condition and starts the Write Colck. If velocity is incorrect, the tape control sets Velocity Retry (LSR 12 bit 7, Data Check 1) and sense byte 8, bit 7 (Velocity Retry) and continues monitoring the Tach Busy line for correct speed.
8. The tape control continues checking velocity until tape is up to speed or for 30 half tach periods. If tape is not up to speed by the end of 30 half tach periods, the tape control sets Velocity Check (LSR 29 bit 7 Equipment Check) and sense byte 10, bit 7, (Velocity Check) and terminates the write operation.

### IBG Generation

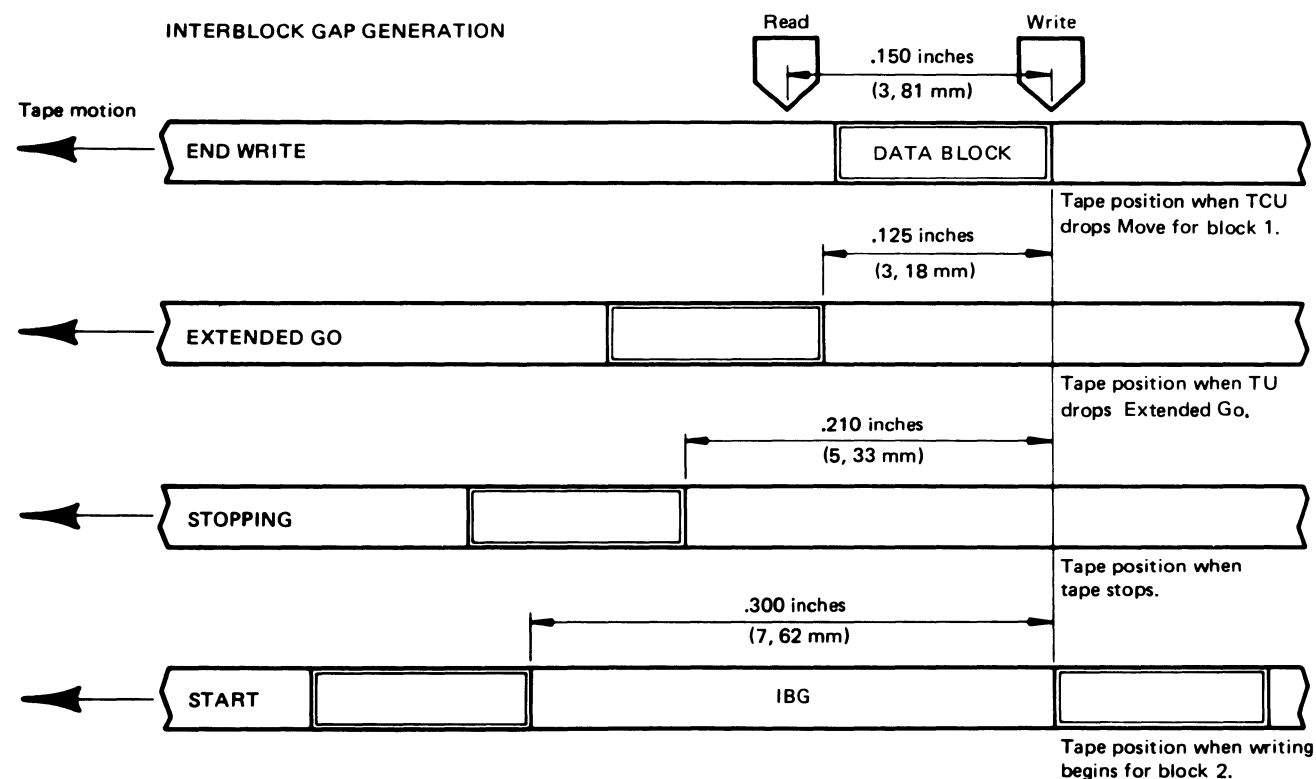

### IBG Timing Chart

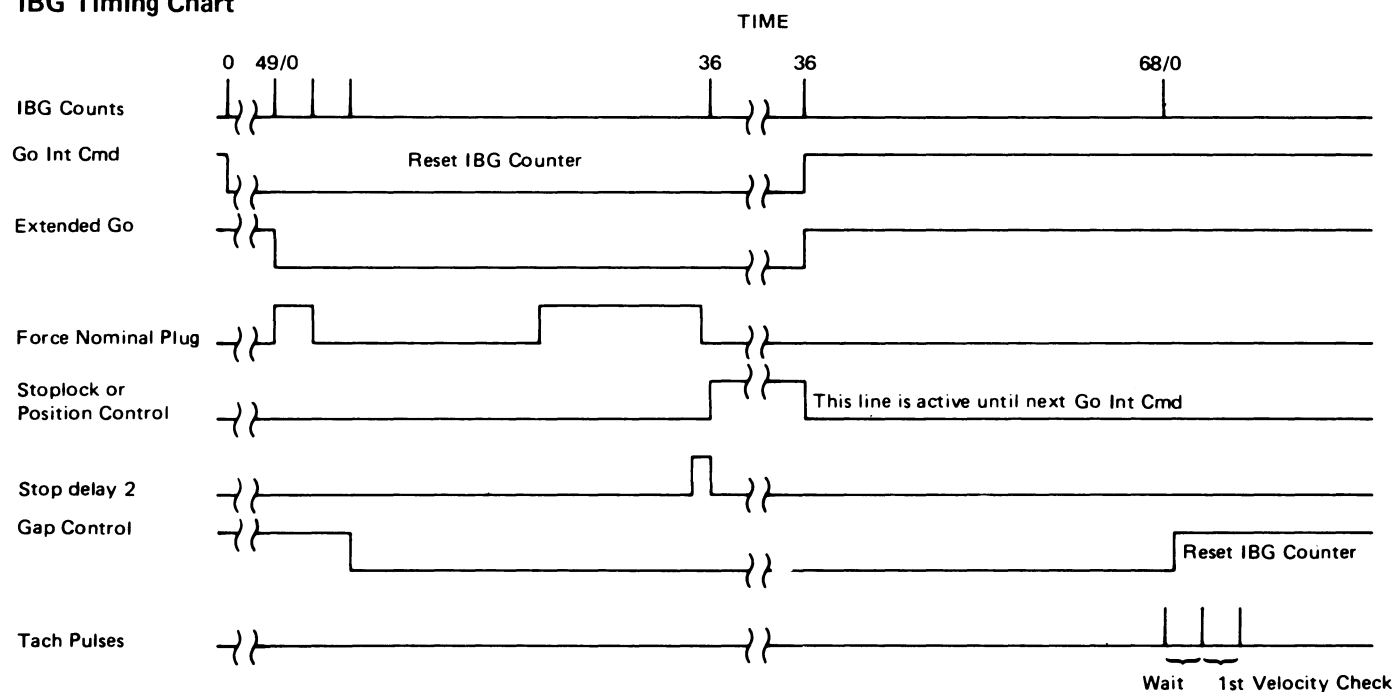

3803-2/3420

XC3200	2735809	See EC	845958						
Seq 1 of 2	Part Number	History	1 Sep 79						

© Copyright International Business Machines Corporation 1976, 1979

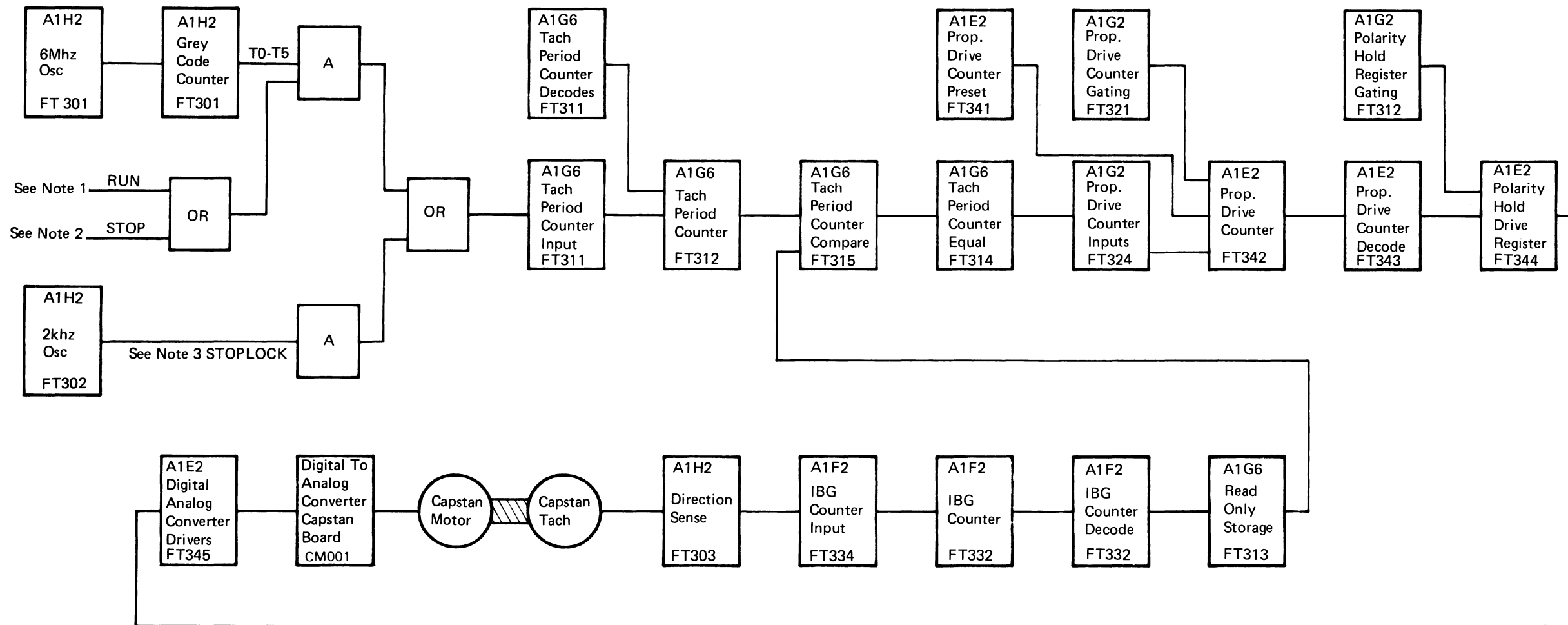

**Notes:**

- [1] RUN refers to nominal speed control.
- [2] STOP refers to deceleration from nominal speed to stopped position.
- [3] STOPLOCK refers to capstan position control.

3803-2/3420

XC3200 Seq 2 of 2	2735809 Part Number	See EC History	845958 1 Sep 79					
----------------------	------------------------	-------------------	--------------------	--	--	--	--	--

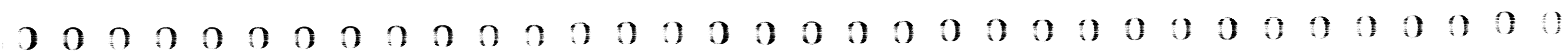

# START CAPSTAN MOTION (WRITE OPERATION 200 IPS)

The tape unit is in a stop condition—Stoplock latch is set. The IBG Counter is stopped with a count of 36.

- A** To start capstan motion (Write Op):
1. The tape control sets Write Status in the tape unit and resets the Backward latch to generate Forward Drive.
  2. The tape control raises the Move tag. Move and Write Status generate Go Internal and Extended Go. Extended Go resets Stoplock latch and activates Gate PDC.

During a full clock cycle (T0 through T5) of the Gray Code counter:

- e** Start Current cycle:
- T1 ANDed with Go Internal activates the Start Current latch -1. Start Current and Forward Drive establish presets for the PDC.
  - T3 ANDed with Start Current activates Set PDC. At this time a count of 34 is set into the PDC.
  - T4 ANDed with Start Current sets the PHD register. PHD register contents are sent to the DAC. The DAC applies armature current and the capstan starts turning forward.
  - T5 ANDed with the Start Current latch—1 activates Start Current latch—2 and degates Start Current.

**Note:** Start Current may remain active until the first quarter tach pulse if the Opposite Direction latch is on. The Opposite Direction latch status is a function of stoplock.

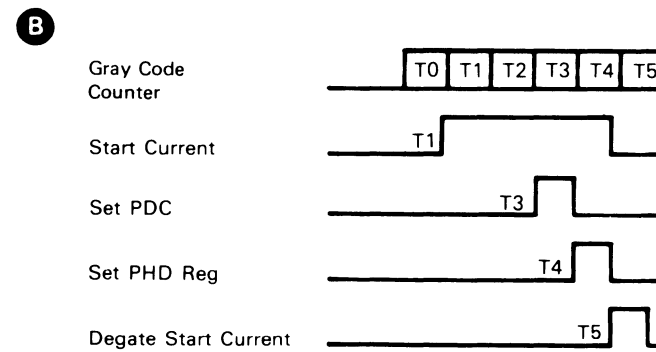
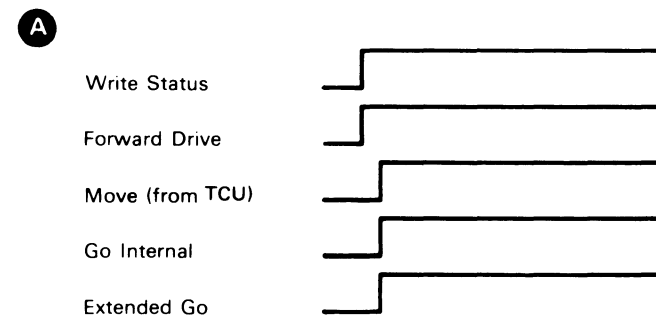

- e** Normal Run cycle:
- T1 ANDed with the positive (phase A) tach transition generates a Normal Run pulse.
  - T2 ANDed with Normal Run pulse transfers the contents of the PDC into the PHD register (still 34 during the first Normal Run).\*
  - T3 The TPC is reset.
  - T4 The PDC is set to -8 (1,2,4,16,32, and sign bits are turned on).

\* Update takes place every Normal Run pulse. Update is shifting the Error Value from the PDC into the PHD.

As the capstan accelerates, the intervals between quarter tach pulses become shorter until capstan speed reaches 100 percent (200 ips). The PDC counts become successively less during acceleration. When the capstan is at 100 percent velocity, the PDC will normally increment to a value between 2 and 4 which reduces motor drive current to 1.5-2.0 amps (just sufficient to overcome friction and maintain speed).

**Note:** As the capstan slows, the PDC count increases and thus more drive current is sent to the motor. When the capstan is over speed, the PDC count is less, which provides less motor drive current.

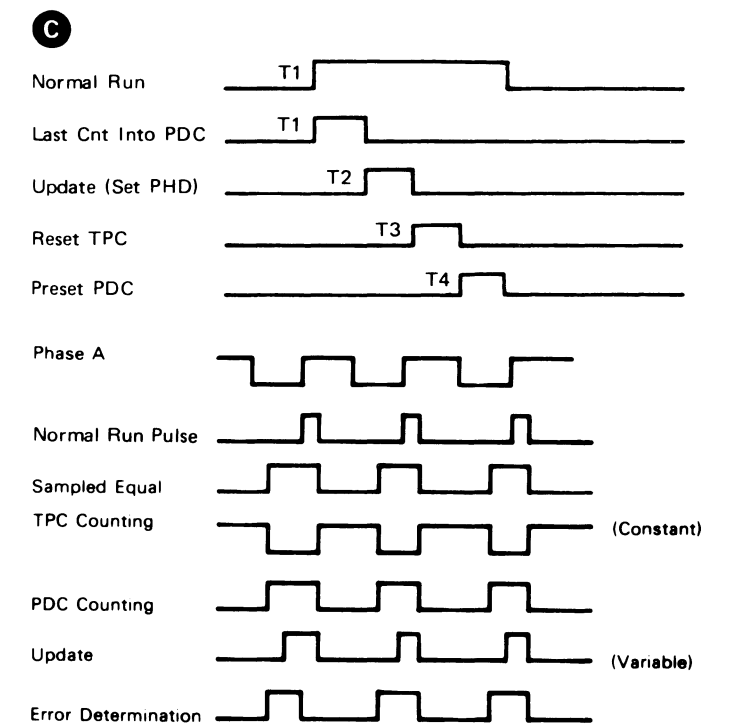

3803-2/3420

XC3300	2735810	See EC History	845958					
Seq 1 of 2	Part Number		1 Sep 79					

© Copyright International Business Machines Corporation 1976, 1979

A write-backspace-write sequence is used to rewrite the last block of a file. Such a sequence causes forward creep.

Forward creep is used to generate a slightly longer than normal interblock gap (IBG). Without forward creep, repeated write-backspace-sequences could shorten the IBG or the previous good record on tape. (Short IBGs cause compatibility problems when tape is used on IBM tape units having different start-stop characteristics).

This figure represents tape motion during a backspace rewrite for Models 4, 6, and 8.

**Backspace Operation: (Read Operation)**

- 1 Tape control deactivates Move after the last byte is read and the IBG counter starts counting. Extended Go holds the Go Internal line active.
- 2 When the IBG counter reaches 16 (6250 bpi) or 90 (1600 bpi), a normal, controlled stop is initiated.

**Backhitch Operation:**

- 3 When the Write command is received, the tape control activates Move and tape moves backward. Forward Status is activated when the microprogram counts 140 tach pulses.
- 4 The tape does not actually stop, but goes through a dynamic reversal. The maximum backward excursion is approximately 0.070 inch (1,78 mm) past count 140.
- 5 Erase Status is set when tape is moving forward and the capstan pulse counter has decremented to 139. The erase head is approximately in the center of the interblock gap.

- 6 The erase head is on and the tape is being erased.

- 7 Write Status is active and Move drops for approximately 5 usec to allow the tape unit to generate an interblock gap.

**Rewrite Operation: (Write Operation)**

- 8 Tape control re-activates Move and tape continues moving forward. Gap Control is activated at IBG count 68 for 6250 bpi or 64 for 1600 bpi.

- 9 Write Condition is not activated in the tape control until eight capstan pulses (1600 bpi) or two capstan pulses (6250 bpi) after Gap Control is active. The first byte of the new block is written approximately 0.12 inch, (3,05 mm) or approximately 12 capstan pulses, beyond the starting position of the old block.

Forward Creep During Rewrite, Models 4, 6 and 8

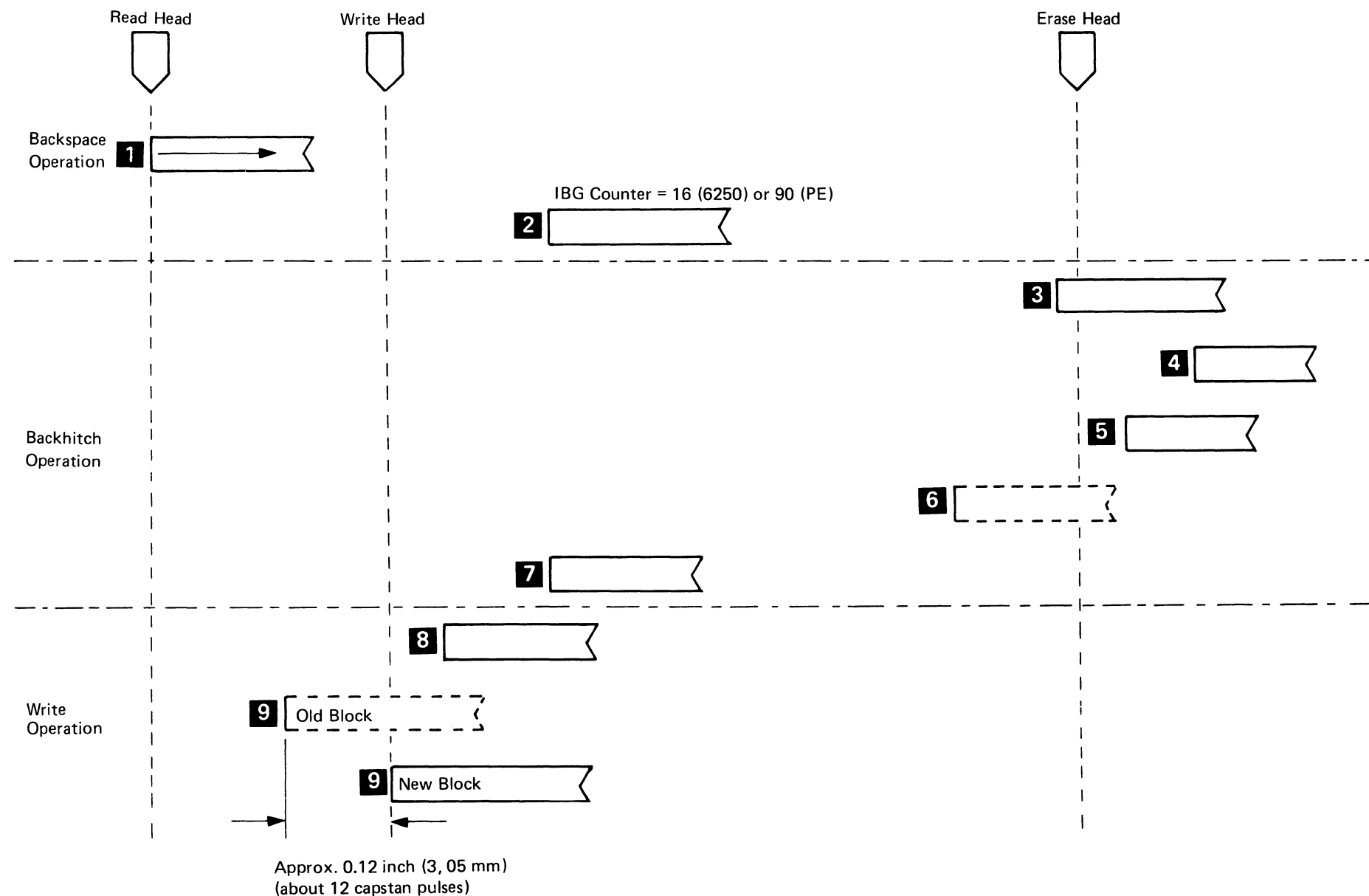

3803-2/3420

XC3300	2735810	See EC	845958					
Seq 2 of 2	Part Number	History	1 Sep 79					

© Copyright International Business Machines Corporation 1976, 1979





# INDEX

**A**  
 Abends-Theory 00-035  
 A/B Read and Sequencing Register 53-055  
 A Register 52-035  
 AC Power Supply (see Power Supplies)  
 Acceptable Waveforms (Read Card Test Points) 5B-004  
 Access Times, Read/Write (Subsystem Characteristics) 40-002  
 Acronyms and Abbreviations PLAN 2  
 Active/Inactive/Pulsing/Switched Line Levels 00-003  
 Adapter Hose (CE Tool) 80-000  
 ADD/ADDM, Arithmetic (ALU Operation) 52-065  
 Additional Stopping Distance After Go Extend 6A-140, 6B-205  
 Address Out Active (MAP) 13-300  
 Address Out Inactive (MAP) 13-360  
 Address/Feature/Priority Card Plugging (Installation) 90-110  
 Address Decoders, Control Unit 58-010  
 Addressing  
 Concepts 40-003  
 Tape Control and Tape Unit 54-005  
 Adjustment  
 Altitude Vacuum Level 08-410, 90-190  
 AMP Sensor (NRZI-Model 3, 5, 7) 08-300  
 Amp Sensor (PE Only-Model 3, 5, 7) 08-290  
 Amplitude (Model 4, 6, 8) 08-310  
 Autocleaner 08-382, 5B-110  
 BOT/EOT, Fiber Optic 08-580  
 BOT/EOT Voltage 08-575  
 Capstan To Stubby Bar Clearance (All Models) 08-080  
 Capstan Tachometer (Model 3, 5, 7) 08-130  
 Capstan Tachometer (Model 4, 6, 8) 08-120  
 Cartridge Motor 08-535  
 Data Flow Clock Asymmetry 90-190  
 DC Power Supply 08-570  
 Dual Density Threshold Adjustment Card 80-000  
 Electrical Skew (NRZI Feature) 08-200  
 ESD Grounding (3420/3803) 90-190  
 Head Mirror Stop (Model 3, 5, 7) 08-350  
 Left Reel Hub and Motor 80-560  
 Mechanical Skew (NRZI Feature) 08-180  
 Mechanical Skew (1600 and 6250 BPI) 08-170  
 Power Window Safety Bail 08-640  
 Read Amplitude (Model 4, 6, 8) 08-310  
 Read Electrical Skew (NRZI Feature) 08-190  
 Type 2272 MST Card 17-800  
 Vacuum Column Door 08-680  
 Vacuum Column Door Glass 08-690  
 Write Electrical Skew (NRZI Feature) 08-200  
 Pneumatics  
 Pressure Level (All Models) 08-420  
 Supply Flat Belt (Type 4) 08-442  
 Power Window Motor, Rack and Switch 08-640  
 Rack and Limit Switch 08-650  
 Read Amplitude (Models 4, 6, 8) 08-310  
 Read Electrical Skew (NRZI) 08-190  
 Right Reel Hub 08-500  
 Safety Bail 08-640  
 Tape Unit Stubby Bar 08-080  
 Write Electrical Skew (NRZI) 08-200  
 7-Track NRZI Threshold Adjustment Card 08-000  
 Air Bearings, MAP 4A-160, 4B-160

Air Pressure Check, Regulator 08-405, 90-190  
 Airflow and Voltage Monitoring System 1A-000, 1B-000  
 Alignments  
 Capstan  
 Dynamic (Non-90,000 series) 08-150  
 Dynamic (90,000 series) 08-160, Marks 08-064  
 Static (Non-90,000 Series) 08-060  
 Static (With Round Supports) 08-068  
 Static (With Square Support Without Zero Marks) 08-062  
 Power Window 08-640  
 Alternate Flip Flop 53-040  
 ALU ((Arithmetic Logical Unit) Microprocessor)  
 Operations  
 Arithmetic Add: ADD/ADDM (Hex Code A or B) 52-065  
 Branch On Condition: BOC (Hex Code 2 or 3) 52-085  
 Branch to Read from Load Point 55-040  
 Branch to Write from Load Point 55-024  
 Branch Unconditional: BU (Hex Code 6) 52-090  
 Common Start I/O Routine 55-020  
 Logical AND: AND/ANDM (Hex Code C or D) 52-070  
 Logical Exclusive OR: XO/XOM (Hex Code E or F) 52-075  
 Logical OR: OR/ORM (Hex Code 8 or 9) 52-075  
 Store Logic: STO (Hex Code 0 or 1) 52-095  
 Transfer Logic: XFR (Hex Code 4 or 5) 52-100  
 ALU1  
 Charts 1 to 7 13-091  
 Fails to Trap to 000 (MAP) 13-400  
 Failure to Reset CTI (MAP) 13-210  
 Hangs at 000 (MAP) 13-010  
 Hangs on ALU2 Failure (MAP) 13-410  
 Loop (MAP) 13-530, 13-540  
 Loop, TCS (MAP) 13-080  
 Microprogram Detected Error (Sense Byte 11, Bit 4) (MAP) 16-060  
 Op In Wait (MAP) 13-250  
 Power-On Reset (MAP) 13-090  
 Reset Failure (MAP) 13-200  
 Waiting for ALU2 to Complete a Sequence (MAP) 13-420  
 Waiting for ALU2 to Drop STATB (MAP) 13-460, 13-470  
 Waiting for ALU2 STATB Indication (MAP) 13-450  
 Waiting for ALU2 STATD Indication (MAP) 13-440  
 ALU Cannot Exit or Loop (MAP) 13-370  
 ALU1 or ALU2 Hangs (Chart) 13-005  
 ALU1 or ALU2 Hangs (MAP) 13-000  
 ALU1/ALU2 (Two Position Switch) 75-002  
 ALU2  
 Analyzing Microprogram Errors 16-131  
 Microprogram Detected Error (Sense Byte 12, Bit 4) 16-130  
 Microprogram Error (Table) 16-130  
 Power-On Reset Charts 1 to 7 13-194  
 Power-On Reset (MAP) 13-190

Trap Failure (MAP) 13-260  
 B Bus Parity Error ALU1 16-030  
 B Bus Parity Error ALU2 16-100  
 Branch On Condition (BOC) Error  
 ALU1 16-050  
 ALU2 16-120  
 Bus In Register, Channel 52-040  
 Bus Out Register, Tape Unit 52-045  
 Card Interchanging List 16-001  
 Channel Bus In (CBI) Register 52-040  
 Channel Tags In (CTI) Register 52-040  
 Communication Between Microprocessors (Description) 52-030  
 Crossover (XOUTA/XOUTB) Registers 52-025  
 D Bus Parity Error ALU2 16-110  
 D Registers 52-060  
 Diagnose, Loop, and Scoping Procedures 16-000  
 General Reference Information 16-000  
 High-Order ROS Registers 52-035  
 High ROS/IC Parity Error On a Branch Instruction  
 ALU1 16-020  
 ALU2 16-090  
 How to Determine the Failing Address 16-000  
 How to Make the ALU Loop on an Error 16-000  
 Linking Microprogram Routines (Description) 52-030  
 Listings, Microprocessor (Description) 52-030  
 Local Storage Register (LSR) 52-015  
 Low-Order ROS Registers 52-035  
 Low ROS/IC Parity Error On a Branch Instruction  
 ALU1 16-010  
 ALU2 16-080  
 Microprocessor  
 Clocks 52-005  
 Instructions (see ALU Operation)  
 Listings (Description) 52-030  
 (MP1/MP2) Schematic 50-003  
 Microprogram Transfer Decodes 52-101  
 MIST or TCS Register (MP1) 52-060  
 MP1 Special Register (Hardware Errors) 52-060  
 MP2 Special Register (TU Bus In) 52-060  
 Parity Error ALU1 16-040  
 ROS 1 Trap Conditions 50-011  
 Second Level Diagram, ROS 1 Trap Conditions 50-010  
 Short Cycle XFR Example (Timing Chart) 16-001  
 Stat Registers 52-015  
 Stop Address-FRU List ALU1 16-060  
 Stop Address-FRU List ALU2 16-130  
 Tags In Register, Channel 52-040  
 Tape Unit Bus Out (TUBO) Register 52-045  
 TCS or MIST Register (MP1) 52-060  
 XOUTA/XOUTB (Crossover) Registers 52-025  
 Amplitude-Setting Sequence 5B-120  
 Analysis of Damaged Tape Errors 00-012  
 Analysis of IBG in Developed Tape 00-013  
 Analyzing Microprogram Errors 16-131  
 AND, Logical (ALU Operation) 52-070  
 Arithmetic Add (ALU Operation) 52-065  
 Array Patching, Patch Card 52-103  
 Asymmetry Adjustment, Clock 17-800  
 Attachment, Channel (Chart) 90-010  
 Autocleaner  
 Adjustment 08-382

Erase Head 5B-110  
 Operation 08-360  
 Operational Check 08-380  
 Removal/Replacement 08-370  
 Solenoid 4B-160  
 Write Card Circuits 5B-110  
 Automated Logic Diagram (ALDs) 00-002  
 Automatic Threading (Concept) 40-001

# B

B Bus  
 B Bus 0-7 ALU1 Test Points (Table) 16-030  
 Parity Error ALU1 (MAP) 16-030  
 Parity Error ALU2 (MAP) 16-100  
 Parity Indicator 75-003  
 Backhitch 6B-230  
 Backspace Block Command 40-007  
 Backspace File Command 40-007  
 Backspace Operation 6B-230  
 Backward  
 No Response or Tape Moves Backward 3A-100  
 Tape Fails to Go Backward 3A-130, 3B-130  
 Bad Sense Data After a Rewind from OLTs (MAP) 15-140  
 Basic Recording Techniques (PE, NRZI, 6250) Description 55-007  
 Basic Subsystem (Concepts) 40-001  
 BCDIC-EBCDIC Conversion Chart (7-Track Operation) 57-020  
 Bit Cell and PE Waveform 55-007  
 Bit Cell and NRZI Waveform 55-007  
 Bit Packing and Scoping Procedure 5A-115, 5B-025  
 Bit Usage Chart, MP1 XOUTA Register 52-025  
 Block Diagram, Device Switching (2x8 Switch) 18-012  
 Block Diagram, Device Switching (3x8 or 4x8 Switch) 18-013  
 BOC Indicator 75-003  
 BOT/EOT  
 Phototransistor 2A-010  
 Load Check Prior to BOT Sense 2A-150, 2B-150  
 Tape Does Not Go Backward or Does Not Stop at BOT 2A-190  
 Tape Moves Backward Off Left Reel 2B-190  
 Tape Unwinds Off Right Reel or TI Light Stays On 3A-150  
 Tape Won't Thread, Load, and Return to BOT Correctly 6B-100  
 Voltage Checks and Adjustments 08-580  
 BOT/EOT, Fiber Optics  
 Block Removal/Replacement 08-590  
 LED BOT/EOT Window Removal/Replacement 08-590  
 LED BOT/EOT Voltage Checks/Adjustments 08-580  
 Branch  
 Condition Error ALU1 (MAP) 16-050  
 MP1 Condition (Table) 52-086  
 MP2 Conditions (Table) 52-087  
 On Condition (ALU Operation) 52-085  
 On Condition Error ALU2 (MAP) 16-120

3803-2/3420

XK0100	2736031	See EC	845958	846927	847298		
Seq 1 of 2	Part Number	History	1 Sep 79	20 Jun 80	15 Aug 83		

© Copyright International Business Machines Corporation 1976, 1979, 1980, 1983

# INDEX 1

**INDEX (Cont'd)**

Unconditional (ALU Operation) 52-090  
 To Write From Load Point 55-024  
 To Read From Load Point 55-040  
 Buffer Write Cycle 53-040  
 Buffers, LSR 52-015  
 Burst Commands 40-005  
 Bus In Register, Channel 52-040  
 Bus In/Bus Out Interface Lines 07-000, 54-000  
 Bus Out Checks (MAP) 15-030  
 Bus Out Register, Tape Unit 52-045  
 Busy (TCS Feature) 58-012  
 Busy/Tach Lines Test Points (Table) 16-171  
 Byte Counter 53-025

**C**

C Compare or P Compare Circuit Logic 17-017  
 C Compare or P Compare Errors 17-010  
 C Compare or P Compare Errors (Timing Chart) 17-014  
 Cable and Terminator Plugging 90-080  
 Cable Retaining Bar 90-060  
 Cables 90-060  
 Cabling, Subsystem 90-060  
 Capstan  
 Adjusters 08-060  
 Adjustment Wrench (CE Tool) 80-000  
 Box Wrench (CE Tool) 80-000  
 Capstan To Stubby Bar Clearance 08-080  
 Drive System 6A-120, 6B-200  
 Dynamic Alignment Tracking (90,00 Series) 08-160  
 Dynamic Alignment Tracking (Non-90,00 Series) 08-150  
 Glazed Cleaning Procedure 08-700  
 Major Elements of Capstan Control Logic 6B-205  
 Motion Checks (Motion Appears Normal) 6B-020  
 Motion Control 6A-000  
 Motion Failure Symptoms 6B-000, 6B-140  
 Motor and Controls 6A-120, 6B-200  
 Motor Proportional Drive Control 6B-215  
 Motor Status 3A-030, 3B-030  
 Motor Waveforms 6A-002  
 Normal Cleaning Procedure 85-004  
 Pulse Generator 6A-120, 6B-200  
 Start Capstan Motion (Write Operation 200 IPS) 6B-220  
 Capstan Assembly  
 Field Repair, Dented Capstans (Non-90,000 Series TU) 08-020  
 Field Repair, Dented Capstans (90,000 Series TU) 08-030  
 Removal (Non-90,000 Series Tape Units) 08-020  
 Removal (90,000 Series Tape Units) 08-030  
 Replacement (Non-90,000 Series Tape Units) 08-040  
 Replacement (90,00 Series Tape Units) 08-050  
 Starts Turning When Power is Turned On (Second Level) 6B-140  
 Static Alignment (Square Support With Zero Marks) 08-064  
 Static Alignment (Square Support Without Zero Marks) 08-062  
 Static Alignment (With Round Supports) 08-068  
 Capstan Tachometer  
 Check/Adjustment (Models 3, 5, and 7) 08-130

Check/Adjustment (Models 4, 6, and 8) 08-120  
 Cleaning 08-140  
 Cleaning Kit 85-000  
 Cleaning Procedure, Special Glazed 08-700  
 Control Circuits, Capstan 6A-120, 6B-200  
 Drive System 6A-120, 6B-200  
 Dynamic Alignment (Non-90,000 Series Tape Units) 08-150  
 Dynamic Alignment (90,000 Series Tape Units) 08-160  
 Extended Go 6A-140, 6B-205  
 Gray Code Counter (GCC) 6B-205  
 IBG Counter Circuits 6A-130, 6B-205  
 Major Elements of Capstan Control Logic 6B-205  
 Motion Checks (Capstan Motion Appears Normal) 6B-020  
 Motion Control Problems 6A-000  
 Motion Failure Problems 6B-000  
 Motor and Controls 6A-120, 6B-200  
 Motor Proportional Drive Control Circuit 6B-215  
 Motor Waveforms 6A-002, 6B-002  
 Polarity Hold Drive (PHD) Register 6B-205  
 Proportional Drive Counter (PDC) 6B-205  
 Pulse Generation 6A-120, 6B-200  
 Quarter Tach Pulses 6B-205  
 Read Only Storage (ROS) 6B-205  
 Start Capstan Motion 6B-220  
 Starts Turning When Power is Turned On 6B-140  
 Static Alignment  
 (With Round Supports) 08-068  
 (90,000 Series, With Zero Marks) 08-062  
 (90,000 Series, Without Zero Marks) 08-064  
 Tach Period Counter (TPC) 6B-205  
 Tape Unit Loads But Capstan Motion is Faulty 6B-110  
 TU Stubby Bar Clearance Adjustment 08-080  
 TU Won't Thread, Load and Return to BOT Correctly 6B-100  
 Won't Start Rewind to LP After Tape Load 2B-175  
 6 MHz Oscillator and GCC 6B-205  
 Capstan Prealignment Gauge (CE Tools) 80-000  
 Card/Board Function Layout (3420) 19-010  
 (3803-2) 19-000  
 Card Isolation Technique PLAN 1  
 Card Plugging (Installation) 90-110  
 Card Plugging, Tape Control Logic Panel 19-000  
 Cartridge  
 Does Not Open 2A-100, 2B-100  
 Opener Does Not Close 4A-150, 4B-150  
 Optional (Concept) 40-001  
 Motor Replacement/Adjustment 08-535  
 Restraint Pressure Check 08-536  
 Restraint Removal/Replacement 08-540  
 CE Initial Entry Flow Chart START 1  
 CE Panel  
 Description 75-001  
 Failures 12-020  
 Operation Contents (MAP) 12-010  
 Switches 75-001  
 Channel  
 Attachment (Chart) 90-010  
 Buffer Controls 53-030  
 Buffer Logic 50-000  
 Bus In 53-055  
 Bus In Register 52-040

Bus In/Out Checking (MAP) 13-380  
 Initial Selection 54-000  
 Interface Problems, Tape Control 18-040  
 Priority Circuits 54-020  
 Status Word Bits (Table) 15-080  
 Tags In Register 52-040  
 Test Points (Table) 17-021  
 Write Byte Register 53-045  
 Characteristics, 3420 Subsystem 40-002  
 Chart  
 ALU1 1 to 7 13-091  
 ALU2 Power On Reset 13-194  
 Branch Conditions 16-050  
 Cards and Cables, Device Switching Troubleshooting Procedure 18-028  
 Dropping Ready and Thread and Load Failure 2A-000  
 Features Chart (Sense Byte 6) 17-220  
 Mode Chart (Sense Byte 6) 17-110, 17-220  
 Read/Write Vertical Redundancy Check 17-170  
 Reference 18-029  
 Skew Error Test Points 17-162  
 Tape Control To/From Device 18-005  
 Tape Unit Control Lines 16-213  
 1x8 Selection 18-001, 18-005  
 Checks  
 Autocleaner Operational 08-380  
 BOT/EOT Voltage 08-580  
 Capstan Tachometer  
 (Model 4, 6, 8) 08-120  
 (Model 3, 5, 7) 08-130  
 Capstan and Tracking 08-010  
 Cartridge Restraint Pressure 08-536  
 Cleaner Blade Gauss 08-390  
 Column Vacuum Level 08-400  
 DC Power Supply 08-570  
 Erase Head Polarity and Erasure 08-320  
 ESD Grounding (3420/3803) 90-190  
 Feedthrough 08-330  
 File Protect Mechanism 08-340  
 Mechanical Skew  
 1600 and 6250 08-170  
 NRZI Feature 08-180  
 Pneumatic Pressure Vacuum 08-400  
 Power Supply 90-180, 08-570  
 Read/Write Head Resistance (Model 4, 6, 8) 08-280  
 Regulator Air Pressure 08-405, 90-190  
 Tape Guide (NRZI Feature) 08-230  
 Tape Unit Grounding 08-600  
 Threading Vacuum 08-400  
 Transfer Valve Plug 08-410  
 Vacuum Column Switch 08-450  
 Vacuum Pump Belt 08-410  
 Check Register, Write 53-045  
 Checking, Read Back (Concept) 40-001  
 Cleaner Blade Gauss Check 08-390  
 Cleaning Procedures (see Preventive Maintenance)  
 Clock  
 Asymmetry Adjustment 17-800  
 Chart 53-015  
 Check (MAP) 17-800  
 Control Logic, Microprocessor 52-005  
 Write (Table) 53-020

Clocks/Oscillators/Counters  
 Byte Counter 53-025  
 CRIC-CROC Address Counters 53-035  
 Data Flow Clock 53-015  
 Group Buffer Counter 53-090  
 Master Clock 53-005  
 Microsecond Frequency 53-005  
 Oscillator Gating 53-005  
 Read Clock Stepping Pulses 53-005  
 Read/Write Clocks and Counters (Table) 53-010  
 Write Clock and Write Counter 53-020  
 Column Vacuum Check 08-400  
 Command Controls Switches (CE Panel) 75-002  
 Command or Control Status Reject 16-160, 6A-160  
 Command Out Inactive During Reset or Power On Reset (MAP) 13-330  
 Command Out Tag Active (MAP) 13-290  
 Command Reject (MAP) 15-020  
 Command Select Sequencer and Decoder 12-026  
 Command Sequence (MAP) 13-050  
 Command Status Reject (MAP) 16-160  
 Commands and Instructions  
 Burst Commands 40-005  
 I/O Instructions 40-009  
 Motion Control Commands 40-007  
 Non-Motion Control Commands 40-008  
 Common Start I/O (SIO) Routine 55-020  
 Communication Between Microprocessors (Description) 52-030  
 Communicator Feature, Device Switch 18-010  
 Communicator (2X8 Switching) 58-080  
 Compare Equal Indicator (CE Panel) 75-003  
 Compare Errors, P Compare or C Compare 17-010  
 Compare Errors, P Compare or C Compare (Timing Chart) 17-014  
 Concepts, 3803-2/3420 40-003  
 Configuration Worksheet Instructions 90-030  
 Configurations, Subsystem (Concepts) 40-003, 90-100  
 Contingent Connection (TCS Feature) 58-012  
 Control Burst 40-002  
 Control Check Indicators (CE Panel) 75-003  
 Control Status Reject (MAP) 16-210  
 Control Unit (see Tape Control)  
 Common Start I/O (SIO) 55-020  
 Sense and Status Byte Table 00-005  
 Control Unit End (TCS Feature) 58-012  
 Conversion, Field Tester 90-170  
 Conversion Table, Sense Byte to Bit 14-005  
 Cooling Fan Assembly Removal/Replacement 08-630  
 Cooling System (see Voltage and Airflow Monitoring System)  
 Counter (IC), Microprocessor 1 Flow Logic 52-010  
 Counters (see Clocks/Oscillators/Counters)

**INDEX 2**

3803-2/3420

XK0100	2736031	See EC History	845958	846927	847298		
Seq 2 of 2	Part Number		1 Sep 79	20 Jun 80	15 Aug 83		

© Copyright International Business Machines Corporation 1976, 1979, 1980, 1983

**INDEX 2**

INDEX (Cont'd)

INDEX 3

CRC  
 Error, NRZI 17-590  
 Error, 6250 BPI/PE 17-540  
 Generation 53-0678  
 Generators 53-065  
 Indicator 75-004  
 Timing Chart 17-544  
 CRIC/CROC Address Registers 53-035  
 Crimper Procedure, Tape (CE Tool) 80-000,  
 2A-015, 2B-006  
 Cross Reference, Pins to Logic (3803-2) 20-000  
 Cross Reference 3803-2, Pins To Logic  
 (Logic) 17-166  
 Crossover (XOUTA/XOUTB) Registers 52-025  
 Crosspoint Section (2X8 Switching) 58-080  
 Crosspoint Switch, Inbound 58-110  
 Crystal Oscillators, Basic Timing 53-005  
 CUE Reset on Interface B (MAP) 13-500  
 Current Generator 58-110  
 Cyclic Redundancy Checks (see CRC)  
 (MAP) 17-540  
 Generation CRC A, B, C, D 53-066  
 During Read Back Check of Write Operations  
 53-067  
 During 9-Track Read Backward Operations  
 53-067  
 During 9-Track Read Forward Operations  
 53-067  
 During 9-Track Write Operations 53-067  
 Read CRC Generator 53-065  
 Write CRC Generator 53-065

D  
 D-Bearing Removal and Replacement  
 (NRZI Feature) 08-210  
 D Bus  
 Parity Error  
 ALU1 (MAP) 16-040  
 ALU2 (MAP) 16-110  
 Parity Indicator 75-004  
 D Registers 52-060  
 Data  
 Converter Check (MAP) 15-070  
 Entry Select Switch (CE Panel) 75-003  
 Exchange on Device Interface During  
 a Write Operation 5A-130, 5B-130  
 Data Flow and Control  
 ALU Schematic 50-003  
 Check Indicators 75-004  
 Clock 53-015  
 Clock Asymmetry Adjustment (Installation) 90-190  
 Exchange on Device Interface During Write Operation  
 5A-130, 5B-130  
 Intermittent Permanent Data Checks  
 Bit Packing 5A-115, 5B-025  
 Forward to Backward Ratio 5B-020  
 Noise or Bit In IBG 5A-115, 5B-025  
 Signal Dropout 5A-110, 5B-020  
 Tape Edge Damage 5A-110, 5B-030  
 Tape Slipping 5B-020  
 Tape Stretch 5A-115, 5B-020  
 Read Data Flow Logic 50-002  
 Read Translator 7-Track 57-002  
 Read/Write Flow Logic 50-002

Write Data Flow Logic 50-001  
 Write Translator 7-Track 57-021  
 7-Track Read Schematic 57-006  
 Security Erase Command 40-007  
 Security Erase Procedure Offline 12-013  
 Data Flow Check Indicators (CE Panel) 75-004  
 Data In 53-040  
 Data Rates (3420 Subsystem Characteristics)  
 40-002  
 DC Power Supply (see Power Supplies)  
 DC71 Patch Card General Description 52-103  
 Dead Track Register 53-075  
 Degausser (CE Tool) 80-000  
 Degaussing, Cleaner Blade 08-390  
 Degaussing, Read/Write Head 08-280  
 Density Feature Combinations (Table) 40-004  
 Description  
 Group Coded Recording 55-008  
 Phase Encoded (PE) 55-007  
 NRZI 55-007  
 6250 BPI 55-007  
 Detection Register 53-005  
 Determine the Failing Instruction Address  
 Procedure, Microprocessor 16-000  
 Developing Solution (CE Tool) 80-000  
 Develop Tape 00-011  
 Device  
 Bus In x to DF Test Points (Table) 17-312  
 Selection Priority 54-020  
 Switching Feature (Description) 58-050, 90-050  
 Block Diagram For 2x8 Switch 18-012  
 Block Diagram For 3x8 or 4x8 Switch 18-013  
 Failure Modes 18-010  
 Feature (Logic) 18-010  
 Inbound Crosspoint Switch 58-110  
 Line Definitions 58-060  
 Operation 58-060  
 Rules and Definitions 18-011  
 Switch Node 58-090, 90-050  
 Tape Subsystem Cabling 18-011  
 Interface  
 Data Exchange on Device Interface During Write  
 Operation 5A-130, 5B-130  
 Lines 07-000, 54-000  
 Device End (TCS Feature) 58-012  
 Device to SDI Logic Lines 18-030, 18-032  
 Diagnostic Mode Set Command 40-008, 55-007  
 Diagnostics, System (Installation) 90-200  
 Diagram  
 Autocleaner Operation 08-360  
 Byte Count or Go Down 12-028  
 CE Entry 12-027  
 Channel Priority 54-020  
 Configuration Worksheet, Subsystem  
 Installation 90-040  
 Device Interface 07-000  
 Device Interface During a Write  
 Operation 5A-130, 5B-130  
 Device Interface During Read Forward  
 Operation 5A-140, 5B-140  
 Device Switching  
 Configuration 58-051, 18-011  
 Feature 18-010  
 Most Probable Cause Analysis 18-015  
 1x8 Selection Logic 18-000  
 2X8 Switch Logic 58-055, 18-012

2X8 Switching Functional Units 58-080  
 2X16 Switch Logic 58-055  
 2x16 Switch Logic 58-060  
 3X8 or 4X8 Switch Logic 18-013  
 4X16 Switch Logic 58-070  
 Display Select Switch and Compare 12-023  
 Group Coded Recording (6250 BPI) 55-008  
 IBG Generation 6A-150, 6B-210  
 Initial Selection 54-000  
 Map Formats 00-001  
 Pneumatic System, Thread Status  
 (Active and Inactive) 4A-161, 4B-161  
 Reel and Capstan Operation During  
 Rewind 3A-030, 3B-030  
 Set and Display CE Register 12-021  
 Set and Display Compare Register 12-022  
 System Diagnostics 90-210  
 Troubleshooting Procedure (MAP) 18-020  
 Write Head Driver Card 08-270  
 Digital to Analog Converter (DAC) Waveforms  
 (Model 4, 6, and 8) 6B-010, 6B-011, 6B-012  
 Digitec 251 Meter (CE Tool) 80-000  
 Display LSR Contents (How To) 12-013  
 Display Select Switch (CE Panel) 75-002  
 Drive (see Tape Unit)  
 Drop Ready Problems, Intermittent 00-005  
 Dropping or Picking Records 15-200  
 Dropping Ready and Thread and Load  
 Failure Symptoms Chart 2A-000, 2B-000  
 Dual Density Threshold Adjustment Card 80-000  
 Dynamic Reversal (MAP) 16-200

E  
 Early Begin Readback Check (MAP) 17-100  
 Easy Load Cartridge (Concept) 40-001  
 EBCDIC/BCDIC Conversion Chart 57-020  
 ECC/CRC Scope points (Table) 17-075  
 ECC/ENV Indicator 75-004  
 Edge Damage, Tape 5B-030  
 Emulator Jumper 90-200  
 Enable Switch 75-001  
 Enable/Disable Switch (Concepts) 40-003  
 Encoded Data Group (GCR) 55-010  
 End Data Check  
 MAP 17-530  
 Logic 17-531  
 End Of Call 00-030  
 Engineering Changes Which Affect MAPs 00-000  
 Entry Select Switch, Data 75-003  
 ENV/ECC Indicator 75-004  
 Envelope  
 Check Circuit Logic 17-315  
 Check Without Skew Error (MAP) 17-220  
 Circuits 5A-100, 5B-100  
 Failure, Runaway, or Read/Write Problems  
 5A-000, 5B-000  
 EOT/BOT (see BOT/EOT)  
 Equipment Checks 16-000  
 Erase  
 Full Width Erasure (Concept) 40-001  
 Gap Command 40-007  
 Head 5B-110

Head Current 40-007  
 Head Polarity and Erasure Checks 08-320  
 Head Removal and Replacement 08-250  
 Error Analysis (see MAPs, Tape Control)  
 Error Analysis Flow Chart, Permanent  
 Read/Write 00-011  
 Error Correction Sense Analysis (MAP) 21-000  
 Example of Typical Flow Through MAPs 00-003  
 Excursions (Wide) in Left Column During HS Rewind  
 3A-160, 3B-160  
 Extended Go 6B-205  
 Extra or Missing Interrupts (A2 Panel) 18-050

F  
 Failure Follows Tape Unit 00-040  
 Failure Modes, Device Switch Feature 18-010  
 Features  
 Card Plugging 90-110  
 Chart for Sense Byte 6 17-220  
 Density Feature Combinations (Table) 40-004  
 Device Switching  
 Cabling Instructions 90-060  
 Line Definitions 58-060  
 Node Logic 58-090  
 Node Schematic 58-080  
 Operation 58-060  
 Theory 58-050  
 2 X 8 Switch Functions (Concepts) 58-080  
 2 X 8 Switch Logic 5B-005  
 2 X 16 Switch Logic 58-060  
 4 X 16 Switch Logic 58-070  
 Nine-Track NRZI 40-004  
 Seven-Track NRZI  
 EBCDIC-BCDIC Conversion Chart 57-020  
 Read Data Convert Data Flow Schematic 57-026  
 Read Translator Data Flow Schematic 57-022  
 Seven-Track Read Data Flow Schematic 57-006  
 Seven-Track Write Data Flow Schematic 57-005  
 Write Data Convert Data Flow Schematic  
 57-025  
 Write Translator Data Flow Schematic 57-020  
 Switching Configurations (Figure) 58-051  
 Two Channel Switch (TCS) 58-010  
 Busy 58-012  
 Contingent Connection 58-012  
 Control Unit End 58-012  
 Device End 58-012  
 Implicit Connection 58-011  
 Interface Switch Control 58-011  
 Partitioning 58-011  
 Reserve/Release Operation 58-011  
 Resets 58-011  
 Selection 58-011  
 Sense Release Command 58-011  
 Sense Reserve Command 58-011  
 Stack 58-012  
 Stack Interrupt 58-012  
 Theory 58-010  
 Tie Breaker 58-012  
 2 Control Switch (Concepts) 58-050  
 3 Control Switch (Concepts) 58-050  
 4 Control Switch (Concepts) 58-050  
 Feedthrough Check 08-330

3803-2/3420

XK0200	2736032	See EC	845958	846927	847298			
Seq 1 of 2	Part Number	History	1 Sep 79	20 Jun 80	15 Aug 83			

INDEX (Cont'd)

INDEX 4

Fiber Optics  
 BOT/EOT Voltage Checks/Adjustments 08-580  
 Bundle Removal/Replacement 08-610  
 Lamp Removal/Replacement/Cleaning 08-620  
 LED BOT/EOT Block Removal/Replacement 08-590  
 LED BOT/EOT Voltage Checks/Adjustments 08-580  
 LED BOT/EOT Window Removal/Replacement 08-590  
 Field Feedback Problem Fixes 00-050  
 Field Replaceable Units (FRUs) PLAN 1  
 Field Tester  
 Accuracy Check 08-290, 08-300, 08-315  
 Conversion 90-170  
 3420 80-020  
 File Protect Indicator Off (MAP) 1A-000, 1B-000  
 File Protect Mechanism Check 08-340  
 File Protection (Concept) 40-001  
 Flag Bytes 1 and 2 (Tables) 40-006  
 Flat Belt Replacement, Pneumatic Supply 08-442  
 Flow Charts  
 Branch To Read From Load Point 55-040  
 Branch To Write From Load Point 55-024  
 Common Start I/O Routine 55-020  
 Read From Load Point 55-040  
 Selection and Priority 54-005  
 Write From Load Point 55-024  
 Flow Through MAPs, Typical (Example) 00-003  
 Format Character Trk x (Table) 17-075  
 Format, Data (see Recording Methods/Formats)  
 Format of MAPs 00-001  
 Format, Microprocessor Instruction 52-030  
 Forward Creep During Rewrite (Model 4, 6, 8) 6B-230  
 Forward Space Block (FSB) Command 40-007  
 Forward Space File (FSF) Command 40-007  
 Forward Start Times (Subsystem Characteristics) 40-002  
 Four Control Switch (Concepts) 58-050  
 Full-Width Erasure (Concept) 40-001  
 Function Layout, Card/Board  
 3420 19-010  
 3803-2 19-000  
 Functions, MP1 and MP2 52-030

**G**

Gating, Oscillator 53-005  
 General Cleaning Instructions 85-000  
 General Information 07-000  
 General Reference Information, Microprocessor 16-000  
 General Reset 50-011  
 Generators, CRC 53-065  
 Generation, CRC 53-067  
 Generation, IBG 6A-150  
 Glazed Capstan Cleaning Procedure 08-700  
 Glossary of Terms PLAN 5  
 Go Extend  
 Additional Stopping Distances After 6A-140, 6B-205  
 Go Extensions in Quarter Tach Pulses 6B-205  
 IBG Counts Models 3, 5, and 7 6A-140

Gray Code Counter (GCC) 6B-205  
 Ground Check, Tape Unit 08-600  
 Group Buffer Control 53-025  
 Group Buffer Counter 53-090  
 Group Coded Recording (GCR) 6250 BPI 55-008  
 GCR, 5260 BPI (Concepts) 40-002  
 GCR Block 55-008

**H**

Halt I/O Instruction 40-009  
 Hardware Errors (MP1 Special Register) 52-060  
 Hardware Pointers 17-602  
 Head, Erase 5B-110  
 Head Mirror Stop Adjustment (Models 3, 5, and 7) 08-350  
 Hex Wrench, Right Reel Hub (CE Tool) 80-000  
 Hi IC Pty/Hi ROS Reg Pty Indicator (CE Panel) 75-003  
 High-Order ROS Registers 52-035, 16-020  
 High ROS/IC Parity Error on A Branch Condition  
 ALU1 (MAP) 16-020  
 ALU2 (MAP) 16-090  
 High-Speed Rewind (see Rewind Operation)  
 High-Speed Rewind Solenoid Check 08-405  
 How To  
 CE Initial Entry Flow Chart Start 1  
 Determine the Failing Instruction Address 16-000  
 Develop Tape 00-011  
 Locate Information PLAN 1  
 Make the ALU Loop on an Error 16-000  
 Operate CE Panel 12-000  
 Use MAPs 00-000, PLAN 1  
 Use Section 18-xxx 18-010

**I**

IBG Counter 2A-010  
 IBG Detected on Write (MAP) 17-080  
 IBM Easy Load Cartridge 40-001  
 ID Burst 40-002  
 ID Burst Check (MAP) 17-050  
 Implicit Connection (TCS Feature) 58-011  
 Inactive/Active/Pulsing/Switched Line Levels 00-003  
 Inbound Crosspoint Switch Schematic (Device Switch Feature) 58-110  
 Indicators, CE Panel 75-003  
 Inhibit Preamble/Postamble 40-005  
 Initial Entry Flow Chart, CE Start 1  
 Initial Selection Description 54-000  
 Initial Selection  
 AB CE 50-011  
 Bus In/Bus Out Lines 54-000  
 Device Interface Lines 07-000  
 Tape Unit 07-000, 54-000  
 Initiating a Rewind 3A-010, 3B-010  
 Initiating Tape Motion 07-010  
 Installation  
 Address/Feature/Priority Plugging (see Card Plugging)  
 Cable and Terminator Plugging 90-060  
 Cable Retaining Bar 90-060  
 Cabling, Subsystem (Chart) 90-070  
 Card Plugging

Address, Tape Control 90-110  
 Data In Handling 90-130  
 Device Selection Priority Assignments (Chart) 90-150  
 Device Switching Feature 90-110  
 Device Switching Feature, Address Control (Chart) 90-140  
 Disconnect In Handling 90-110  
 NRZI Feature 90-120  
 Primary/Secondary TU Interface Control (With Device Switch) 90-130  
 Primary/Secondary TU Interface Control (With 1x8) 90-130  
 Priority Assignments, Device Selection (Chart) 90-150  
 Select Out Priority 90-120  
 Serial No/EC Level/Feature Code (Tape Control) 90-210  
 Serial No/Model No/EC Level/Feature Code (Tape Unit) 90-212  
 Tape Control Address 90-110  
 Tape Switching Feature, Address Control (Chart) 90-140  
 Two Channel Switch Feature 90-120  
 3803 Address 90-110  
 Checklist 90-020  
 Checks and Adjustments (Installation)  
 Air Bearing Pressure, 3420 90-190  
 Altitude Vacuum Level Setting, 3420 90-190  
 Autocleaner 90-190  
 BOT/EOT Check 90-190  
 Capstan Check 90-190  
 Data Flow Clock Asymmetry Adjustment, 3803 90-190  
 ESD Grounding 90-190  
 Mechanical Skew, 3420 90-190  
 Configuration Worksheet (Instructions) 90-030, 90-040  
 Device Switch Cabling 90-050  
 Emulator Jumper 90-200  
 Field Tester Conversion 90-170  
 Installation Checklist 90-020  
 Instructions, Subsystem Installation 90-000  
 I/O Interface 40-003  
 Kickplates 90-090, 90-100  
 Operator Panel Labels, Tape Control 90-160  
 Plugging, Cables and Terminators 90-060  
 Power Requirements, Special-3420 Model 8 90-180  
 Power Supply Checks  
 Procedures 90-020  
 Special Power Requirements-3420 Model 8 90-180  
 Subsystem Cabling (Chart) 90-070  
 System Diagnostics 90-200  
 Terminator and Cable Plugging 90-060  
 Instructions (see Commands and Instructions)  
 Instruction Counter, Microprocessor 1 52-010  
 Interblock Gap (IBG)  
 Counter Logic 6A-130, 6B-205  
 Detected on Write 17-080  
 Generation 6A-150, 6B-210  
 Go Extend IBG Counts (Model 3, 5, 7) 6A-140  
 Noise or Bit In 5A-115, 5B-025

Passing Times (3420 Subsystem Characteristics) 40-002  
 Subsystem Characteristics 40-002  
 Timing Chart (Model 5) 6A-150  
 Interface Disabled Indicator (CE Panel) 75-003  
 Interface Switch Control (TCS Feature) 58-011  
 Intermittent Drop Ready Problems 2A-005, 2B-005, 07-010  
 Interrupt 54-000  
 Interrupts, Extra or Missing (A2 Panel) 18-050  
 Intervention Required (MAP) 15-010  
 Introduction to Maintenance Philosophy PLAN 1  
 Introduction, Subsystem Installation 90-000  
 I/O Instructions (see Commands and Instructions) 40-009  
 I/O Pins (3 Bit Code) 12-023, 12-024

**K**

Kickplates, Installation 90-090, 90-100

**L**

Lamp, Skew Check 53-085  
 Lamp Test Switch (CE Panel) 75-002  
 Latch, Reel (see Right Reel Latch)  
 Left Movable Guide and Retractor Removal and Replacement (NRZI Feature) 08-220  
 Left or Right Vacuum Column Problems 2A-170, 2B-170, 3A-110, 3B-110  
 Left Reel  
 Does Not Turn Clockwise at Threading Speed 2A-110, 2B-110  
 Hub and Motor Removal/Replacement/Adjustment 80-560  
 Logic 3A-030, 3B-030  
 Motor Speed, Voltages 3A-020, 3B-020  
 Right or Left Reel Won't Load Tape Into Column 2B-180  
 Tape Rewinds Off Left Reel 3B-180  
 Theory, Rewind and Timing Chart 3A-010, 3B-010  
 Left Threading Channel 08-230  
 Legend and Symbols PLAN 4  
 Light Source Removal/Replacement 08-620  
 Lights/Indicators (see Maintenance Procedures)  
 CE Panel 75-001  
 File Protect Indicator Off 1A-000, 1B-000  
 Load Check Prior to BOT Sense 2A-150, 2B-150  
 Power Check Indicator On 1A-000, 1B-000  
 Ready Lamp Does Not Turn Off 4A-100, 4B-100  
 Ready Lamp Does Not Turn On 2A-210, 2B-210  
 TI Lamp Stays On 3A-150, 3B-150  
 Line Definitions, Device Switching Feature 58-060  
 Line Levels - Active/Inactive/Pulsing/Switched 00-003  
 Line Names for Reference to ALD XC70x (Table) 18-020  
 Linking Microprogram Routines (Description) 52-030  
 Listings, Microprocessor 52-030  
 Lo IC Pty/Low ROS Reg Pty Indicator 75-003  
 Load Check 2A-000, 2B-000

3803-2/3420

XK0200	2736032	See EC History	845958	846927	847298			
Seq 2 of 2	Part Number		1 Sep 79	20 Jun 80	15 Aug 83			

INDEX 4

INDEX (Cont'd)

Load Failure Symptoms (MAP) 2A-000, 2B-000  
 Load Check Prior to BOT Sense 2A-150, 2B-150  
 Loading Tape in Columns 2B-175  
 Load Operation, Approximate Time (3420 Subsystem Characteristics) 40-002  
 Load Test, Minireel 08-800  
 Local Storage Register (LSR)  
 Displaying Contents 12-013  
 Operation 52-015  
 Locating Information PLAN 1  
 Locations  
 Control Unit  
 Tape Unit  
 Air Bearing Switch 2B-160  
 BOT/EOT Block 3A-150, 3B-150  
 Cartridge Motor 4B-150  
 Cartridge Open Switch 4B-150  
 Cartridge Opener Control Card 4B-150  
 CP3 2A-130, 2B-130  
 Fiber Optic 2B-150  
 Fuses 1A-000, 1B-000  
 Manual Status Control (MSC) Card 4B-110  
 Pneumatic Contactor 2A-130, 2B-130  
 Pneumatic Supply 2A-210, 2B-210  
 Power Interface Board B1 1A-003, 1B-001  
 Power Window PCB 2A-210, 2B-210  
 Power Window Switches 4B-140  
 Reel Motor Power Board 2A-140, 2B-140  
 Reel Tachometers 3A-170, 3B-170  
 Reels Loaded Switch 4A-140, 4B-140  
 Regulator Cards 1A-002, 1B-002  
 SCRA 2B-160  
 TB-1, 2, and 3 1A-002, 1B-002  
 Transfer Valve Solenoid 2A-130, 2B-130  
 Y1 Panel Location 90-080  
 Lock ROS 1 IC 50-011  
 Logic  
 A Register 52-035  
 Arithmetic Add 52-065  
 Branch On Condition 52-085  
 Branch Unconditional 52-090  
 Byte Count or Go Down 12-028  
 Capstan Control, Pulse Generator, and Motor Controls 6A-120, 6B-200  
 Capstan Fails To Start a Rewind To Load Point Operation After Loading Tape into Columns 2B-175  
 Cartridge Does Not Open 2A-100, 2B-100  
 Cartridge Opener Does Not Close 4A-150, 4B-150  
 CE Entry 12-027  
 Channel Buffer Controls 53-030  
 Channel Tags In and Channel Tags Out Register 52-040  
 Channel Write Byte, Write Check, and Pointer Registers 53-045  
 Command Select Sequencer and Decoder 12-026  
 CRC Generators 53-065  
 D Register 52-060  
 Data Flow Clock 53-015  
 Dead Track 53-075  
 Device Switch Node 58-090  
 Device Switching 58-050  
 End Data Check 17-531  
 Envelope and Read/Write  
 Model 3, 5, 7 5A-100  
 Model 4, 6, 8 5B-100  
 Envelope Check 17-315  
 Group Buffer Counter 53-090  
 Inbound Crosspoint Switch 58-110  
 High-Order ROS Register 52-035  
 Left Reel Does Not Turn Clockwise at Threading Speed 2A-111, 2B-111  
 Left or Right Vacuum Column Problems 2A-170, 2B-170, 3A-110, 3B-110  
 Load Check Prior To BOT Sense 2A-150, 2B-150  
 Logical AND 52-070  
 Logical Exclusive OR 52-080  
 Logical OR 52-075  
 Loop-Write-To-Read (LWR) 55-005  
 Low-Order ROS Register 52-035  
 Microprocessor Clocks Control 52-005  
 MP1 IC (Instruction Counter) 52-010  
 MP1/MP2 Circuits 50-003  
 MP1/MP2 Special registers 52-060  
 MP1/MP2 STAT Registers 52-015  
 MIST or TCS Register 52-060  
 Multi-Track Error (Logic) 17-112  
 No Response or Tape Moves Backward 3A-100, 3B-100  
 NRZI Read Data Flow 57-006  
 Oscillator Gating 53-005  
 Overrun 15-042  
 P or C Compare 17-017  
 Power Window Does Not Go Down 4A-140, 4B-140  
 Proportional Drive Control 6B-215  
 Read Cycle Controls 53-095  
 Read Data Converter 57-026  
 Read Data Flow 50-002  
 Read Head and Read Card 5B-120  
 Read Sequencing and A/B Registers 53-055  
 Read Translator 57-021  
 Read/Write Flow 50-000  
 Read/Write VRC Circuit 17-179  
 Ready Lamp Does Not Turn Off 4A-100, 4B-100  
 Ready Lamp Does Not Turn On/Window Does Not Close 2A-210, 2B-210  
 Reel and Capstan Operation during Rewind 3A-030, 3B-030  
 Reel Drive System 3b-020  
 RIC/ROC 53-081  
 Right or Left Reel Fails To Load Tape Into Column 2B-180  
 Right Reel Does Not Turn Clockwise at Threading Speed 2A-120, 2B-120  
 ROS/LSR 52-015  
 ROS Mode Switch and Gates 12-024  
 ROS 1 Trap Conditions 50-010  
 Skew Detection 53-085  
 System 360/370 Switching (Data In Handling) 58-005  
 Tape Does Not Enter or Stay in High Speed Rewind or Rewinds To BOT at High Speed 3A-170, 3B-170  
 Store 52-095  
 Tape Does Not Go Backward or Does Not Stop at BOT 2A-190  
 Tape Does Not Load Into Either Column 2A-160, 2B-160  
 Tape Does Not Pull Out of Columns Properly During Unload Rewind 4A-120, 4B-120  
 Tape Does Not Stop or Tape Runaway

INDEX 5

(Forward or Backward 3A-140, 3B-140  
 Tape Does Not Wind Completely Onto Right Reel or Reels Do Not Stop 4A-130, 4B-130.  
 Tape Fails To Go Backward 3A-130, 3B-130  
 Tape Goes Forward After Loading Into Vacuum Columns 2A-200, 2B-200  
 Tape Moves Backward Off Left Reel, or Tape Unit Performs a Normal Unload Rewind During Load Operation 2B-190  
 Tape Pulls Out, Dumps, or Has Wide Excursions in Left Column During High Speed Rewind 3A-160, 3B-160  
 Tape Threads Into Threading Channel and Stops 2A-140, 2B-140  
 Tape Threads Into Right Column 2B-130  
 Tape Unit Bus Out (TUBO) Register 52-045  
 Tape Unit Selection Priority 54-010  
 Tape Unwinds Off Right Reel 3A-150, 3B-150  
 TCS Selection and Tie Breaker 58-030  
 Transfer 52-100  
 Transfer Valve Does Not Pick or Pneumatic Motor Not Running 2A-130  
 Two-Channel Switch 58-010  
 Two-Channel Switch and Tie Breaker 58-030  
 Unload Rewind Pushbutton (No Response) 4A-110, 4B-110  
 Write 53-070  
 Clock and Write Counter 53-020  
 Data Converter 57-025  
 Data Flow 50-001  
 Group Buffer Control 53-025  
 Write Head, Erase Head, and Write Card 5B-110  
 Service Controls 53-040  
 Translator 57-020  
 Triggers 53-070  
 Trigger VRC 17-026  
 2x8 Switching Functional Units 58-080  
 Logic Panel Removal/Replacement (3803/3420) 08-630  
 Logic, Pins, Cross Reference List 20-000  
 Logic Section (2X8 Switching) 58-080  
 Logical AND (ALU Operation) 52-070  
 Logical Exclusive OR (ALU Operation) 52-080  
 Logical OR (ALU Operation) 52-075  
 Long Cycle BOC or BU Example (Timing Chart) 16-001  
 Loop, ALU1 (MAP) 13-530, 13-540  
 Loop Write-to-Read (LWR) Command 40-006, 55-005  
 Tape Unit Operation 55-005  
 Low-Order ROS Registers 52-035, 16-010  
 Low ROS/IC Parity Error on a Branch Condition (ALU2) (MAP) 16-080  
 Low ROS/IC Parity Error on a Branch Instruction (ALU1) (MAP) 16-010  
 Low Speed Rewind 3A-010, 3B-010  
 LWR Tape Unit Operation 55-005  
 M  
 Magnetic Tape and Reels (Concepts) 40-002  
 Preventive Maintenance  
 General Cleaning Instructions 85-000  
 Schedule 85-005  
 Tape Unit Cleaning Procedure 85-001  
 Maintenance Philosophy, Introduction PLAN 1  
 Major Elements of Capstan Control Logic 6B-205  
 Make the ALU Loop on an Error (Procedure) 16-000  
 MAPs  
 Address Out Tag Active 13-300  
 ALU Cannot Exit or Loop 13-370  
 ALU1  
 Cannot Transfer 13-130  
 Fails to Trap to 000 13-400  
 Failure to Reset CTI 13-210  
 Hangs at 000 13-010  
 Hangs on ALU2 Failure 13-410  
 Loop 13-530, 13-540  
 Loop, TCS 13-080  
 Microprogram Detected Error (Sense Byte 11, Bit 4) 16-060  
 Op In Wait 13-250  
 Power On Reset 13-090  
 Reset Failure 13-200  
 Waiting 13-110, 13-140, 13-170  
 Waiting for ALU2 to Complete a Sequence 13-420  
 Waiting for ALU2 to Drop STATB 13-460, 13-470  
 Waiting for ALU2 STATB Indication 13-450  
 Waiting for ALU2 STATD Indication 13-440  
 Waiting for End of Data (EOD) on Write 13-520  
 ALU1 or ALU2 Hangs 13-000  
 ALU2  
 Power On Reset 13-190  
 Trap Failure 13-260  
 B Bus Parity Error (ALU1) 16-030  
 B Bus Parity Error (ALU2) 16-100  
 Bad Sense After a Rewind from OLTs 15-140  
 Branch Condition Error ALU1 16-050  
 Branch On Condition Error (ALU2) 16-120  
 Bus Out Checks 15-030  
 Capstan Motion Control 6A-000, 6B-000  
 CE Panel Operation 12-010  
 Channel Bus In/Out Checking 13-380  
 Clock Check 17-800  
 Command or Control Status Reject 6A-160  
 Command Out Inactive During Reset or Power On Reset 13-330  
 Command Out Reject 15-020  
 Command Out Tag Active  
 Command Sequence 13-050  
 Command Status Reject 16-160  
 Control Status Reject 16-200  
 CUE Reset on Interface B 13-500  
 Cyclic Redundancy Checks 17-540  
 D Bus Parity Error  
 ALU1 16-040  
 ALU2 16-110

3803-2/3420

XK0300	2736033	See EC	845958	847298			
Seq 1 of 2	Part Number	History	1 Sep 79	15 Aug 83			

INDEX 5

INDEX (Cont'd)

Data Converter Check 15-070  
 Device Switching Feature  
     Most Probable Cause Analysis 18-015  
     Troubleshooting Procedure 18-020  
 Dropping Ready and Thread and Load  
     Failure Symptoms 2A-000, 2B-000  
 Dynamic Reversal 16-200  
 Early Begin Readback Check 17-100  
 End Data Check 17-530  
 End Of Call 00-030  
 Envelope Check Without Skew Error 17-220  
 Envelope Failure, Runaway, or Read/Write  
     Problems 5A-000, 5B-000  
 Error Correction Sense Analysis 21-000  
 File Protect Indicator Off or Power  
     Check Indicator On 1A-000, 1B-000  
 Formats 00-001  
 High ROS/IC Register Parity Branch Condition  
     ALU1 16-020  
     ALU2 16-090  
 How to Use 00-000  
 IBG Detected on Write 17-080  
 ID Burst Check 17-050  
 Intervention Required 15-010  
 LRCR Errors, Sense Byte 3, Bits 0, 1,  
     or 4 17-310  
 Low ROS/IC Parity Error on a Branch Condition  
     (ALU2) 16-080  
 Low ROS/IC Parity Error on a Branch Instruction  
     (ALU1) 16-010  
 MTE Without Envelope Check 17-110  
 No Block Detected on Write/Write Tape Mark  
     (WTM) 16-190  
 Noise Detection 17-370  
 Not Capable 15-060  
 NRZI Cyclic Redundancy Check (CRC) 17-590  
 Offline Duplication of Online Failures 12-000  
 Overrun 15-040  
 P Compare or C Compare Errors 17-010  
 Partial Record (Sense Byte 5, Bit 5) 17-410  
 PE or NRZI and GCR Velocity Checks/Changes  
     16-180  
 Permanent Data Checks 5A-105, 5B-002  
 Picking/Dropping Records 15-200  
 Pointer System 17-602  
 Postamble Error 17-190  
 Read/Write Vertical Redundancy Check (VRC)  
     17-168  
 Sense All Zeros 15-080  
 Sense Analysis 14-000  
 Service Out Tag Active 13-280  
 Single Tape Unit Problems 00-040  
 SIO Trap Failures 13-320  
 Slow End Readback Check 17-150  
 Start Read Check 17-070  
 Suppress Out Active 13-310  
 Suppress Out Inactive During Reset or  
     Power On Reset 13-340  
 TACH Start Failure (Sense Byte 10, Bit 5)  
     16-170  
 TACH Velocity Error 13-510  
 Tape Control Metering Problems 18-060  
 Tape Control Power Supply 11-000  
 Tape Motion and Rewind Symptoms 3A-000,  
     3B-000  
 Tape Unit Loads but Capstan Motion is

Faulty 6B-110  
 Tape Unit Wont Thread, Load, and Return  
     to BOT Properly 6B-101  
 Unit Check Without Supporting Sense  
     or Unexpected Sense 15-100  
 Unload Failure Symptoms 4A-000, 4B-000  
 Write Current Failure or Tape Unit Check 15-090  
 Write Tape Mark (WTM) Check 17-180  
 Write Trigger Vertical Redundancy Check  
     (VRC) Error 17-020  
 XOUTA Register Not Functioning 13-430  
 1x8 Selection Logic 18-000  
 301 Trap Address, TCS or Device Switching  
     Without TCS 13-240  
 3420/3803 Symptom Index 00-010  
 3803 Status Pending 13-220  
 6250 Error Correction 17-600  
 Markers, BOT/EOT 40-007  
 Master Clock 53-005  
 Master Signal Level Tapes (CE Tool) 80-000  
 Master Skew Tapes (CE Tools) 80-000  
 Mechanical Skew (Installation) 90-190  
 Mechanical Skew Check/Adjustment, NRZI Featured  
     Units 08-180  
 Mechanical Skew Check/Adjustment, 1600 and 6250  
     BPI Units 08-170  
 Meter, Torque  
 Metering (Concepts) 40-003  
 Metering Problems, Tape Control 18-060  
 Microprocessor (see also ALU)  
     Card Interchange List 16-001  
     Clock Control Logic 52-005  
     Communication Between ALU1 and ALU2  
         (Description) 52-030  
     Diagnose, Loop, and Scoping Procedures 16-000  
     Functions (Description) 52-030  
     Instruction Counter Logic 52-010  
     Instruction Format 52-030  
     Listings (Description) 52-030  
     Stat Registers 52-015  
 Microprogram Address, Used in MAPs  
     (Description) 00-003  
 Microprogram Detected Error, ALU1 (MAP) 16-060  
 Microprogram Error, ALU2 (Table) 16-130  
 Microprogram Error Labels (Table) 16-060  
 Microprogram Errors, Analyzing (Table) 16-131  
 Microprogram Flowcharts  
     Branch to Read From Load Point 55-040  
     Branch to Write From Load Point 55-024  
     Common Start I/O Routine 55-020  
 Microprogram Indicators 75-004  
 Microsecond Frequency 53-005  
 Minireel Load Test 08-800  
 Missing or Extra Interrupts 18-050  
 MIST or TCS Register (MP1) 52-035, 52-060  
 MLM Tab Placement by Volume PLAN 7  
 Mode Chart for Sense Byte 6 17-220  
 Mode Set Command Table 40-008  
 Mode Set 1 (7-Track NRZI) Operation 55-007  
 Mode Set 2 (9-Track PE/NRZI) Operation 55-007  
 Modified Power Supply, 3420 1A-002  
 Motion Control Commands 40-007  
 Motion Control Commands (Table) 40-005  
 Motion Problems, Tape (Stubby Column Loops)  
     6A-010  
 Motion Tester (see Field Tester)

Mple/Single Switch (CE Panel) 75-002  
 MP1 (see ALU)  
     A-Register 52-035  
     Branch Conditions (Table) 52-086  
     Clock Control Logic 52-005  
     Clock Timing Charts 52-005  
     Functional Description 52-030  
     High-Order ROS Registers 52-035  
     Instruction Counter Logic 52-025  
     Low-Order ROS Registers 52-035  
     Schematic 50-003  
     Special Register (Hardware Errors) 52-060  
     Stat Registers 52-015  
     Transfer Decodes (Table) 52-101  
     XOUTA Register Bit Usage 52-025  
 MP2 (see ALU)  
     A-Register 52-035  
     Branch Conditions (Table) 52-087  
     Functional Description 52-030  
     High-Order ROS Registers 52-035  
     Instruction Counter Logic 52-030  
     Low-Order ROS Registers 52-035  
     Schematic 50-003  
     Special Register (TU Bus In) 52-040  
     Stat Registers 52-015  
     Transfer Decodes (Table) 52-101  
     XOUTA Register Bit Usage 52-025  
 Multi-Track Error (MTE)  
     Logic 17-112  
     MTE/LRC Indicator 75-004  
     Without Envelope Check (MAP) 17-110

N

9-Track NRZI (Concepts) 40-002  
 9-Track NRZI Feature (Tape Control) 40-004  
 No Block Detected on Write/Write Tape Mark  
     (WTM) 16-190  
 No-Operation (NOP) Command 40-008  
 No Response or Tape Moves Backward 3A-100,  
     3B-100  
 No Response When Rewind/Unload Button is  
     Pressed 4A-110, 4B-110  
 Noise Detection (MAP) 17-370  
 Noise or Bits in the Interblock Gap 5A-115, 5B-025  
 Non-Motion Control Commands 40-008  
 Non-Motion Control Commands (Table) 40-005  
 Not Capable (MAP) 15-060  
 Not Capable Conditions (Table) 15-064  
 NRZI  
     Cyclic Redundancy Check (CRC) (MAP) 17-590  
     Hi-Clip VRC (Write Only) 17-310  
     Read Data Bit x Test Points (Table) 17-590  
     Read Data Flow 57-006  
     R/W VRC, Hi Clip VRC, LRC Error 17-314  
     7-Track (Concepts) 40-002  
     9-Track (Concepts) 40-002

O

Offline Duplication of Online Failures (MAP) 12-001  
 OLT Error Messages Analysis 21-000  
 OLT-3420 F, G, H, Error Sense Analysis 21-000  
 One and Two Track 6250 Error Correction 17-600  
 Online and Offline Status (Concepts) 40-003

INDEX 6

Operation, Autocleaner 08-360  
 Operational Check, Autocleaner 08-380  
 Operations, ALU  
     Arithmetic Add: ADD/ADDM (Hex Code A or B)  
         52-065  
     Branch On Condition: BOC (Hex Code 2 or 3)  
         52-085  
     Branch to Read from Load Point 55-040  
     Branch to Write from Load Point 55-024  
     Branch Unconditional: BU (Hex Code 6)  
         52-090  
     Common Start I/O Routine 55-020  
     Logical AND: AND/ANDM (Hex Code C or D)  
         52-070  
     Logical Exclusive OR: XO/XOM (Hex Code E or F)  
         52-075  
     Logical OR: OR/ORM (Hex Code 8 or 9)  
         52-075  
     Store Logic: STO (Hex Code 0 or 1)  
         52-095  
     Transfer Logic: XFR (Hex Code 4 or 5) 52-100  
 Operator Panel Switches (2X8 Switch  
     Logic) 58-055  
 Optional Tape Cartridge (Concept) 40-001  
 ORC Byte 53-045  
 Organization of Publication PLAN 6  
 Oscillator Gating 53-005  
 Oscillators (see Clocks/Oscillators/Counters)  
 Other (Related) Subsystem Documents PLAN 1  
 Overrun  
     Error 53-040  
     MAP 15-040  
     PE and 6250 BPI (Timing Chart) 15-041

P

P Compare Error Test Points (Table) 17-013  
 P Comp Indicator (CE Panel) 75-004  
 P Compare or C Compare (Logic) 17-017  
 P Compare or C Compare Errors (MAP) 17-010  
 Panel, CE 75-001  
 Panel Enable Switch 75-001  
 Parity Error, B Bus, ALU1 16-030  
 Parity Error, B Bus, ALU2 16-100  
 Parity Indicator 75-003  
 Partial Record (MAP) 17-410  
 Partitioning (TCS Feature) 58-011  
 Passing Times per Byte (3420 Subsystem  
     Characteristics) 40-002  
 Passing Times, IBG (Subsystem Characteristics)  
     40-002  
 Patch Card  
     ALU1/ALU2 Card Location 52-104  
     General Description 52-103  
     Card Plugging Layout 52-104  
 PE or NRZI and GCR Velocity Checks/Changes (MAP)  
     16-180  
 PE Threshold Adjustment Card 80-000  
 PE, 1600 BPI (Concepts) 40-002  
 PE/6250 BPI CRC 17-540  
 Permanent Data Checks (MAP) 5A-105, 5B-002  
 Permanent Read Error Scoping Offline 00-013  
 Permanent Read Error Scoping Online 00-014  
 Permanent Read/Write Error Analysis  
     Flow Chart 00-011

3803-2/3420

XK0300	2738033	See EC	845958	847298				
Seq 2 of 2	Part Number	History	1 Sep 79	15 Aug 83				

INDEX 6

INDEX (Cont'd)

Permit Flip Latch 53-040  
 Persistent Pointers 17-602  
 Phase Encoded (PE) 55-007  
 Phase Pointers (Table) 08-250  
 Phasing Check (Installation) 90-180  
 Phasing, Power 90-180  
 Photo Cell, Radius Sensor 08-610  
 Picking/Dropping Records (MAP) 15-200  
 Pins to Logic, Cross Reference List (3803-2) 20-000  
 Plugging, Cables and Terminators 90-060  
 Plugging, Reverse High Power Drive Current To Capstan (Model 7 Only) 6A-140  
 Plugging, Write Head Card (Model 4, 6, 8) 08-270  
 Pneumatic System  
   Imbalance or Leaks Check 6A-010, 6B-150  
   Motor Does Not Turn Off 4A-160, 4B-160  
   Motor Not Running or Transfer Valve Not Picked 2A-130, 2B-130  
   Motor Stepped Pulley Alignment (Type 3 Supply) 08-434  
   Pressure Level Adjustment (All Models) 08-420  
   Pressure/Vacuum Checks 08-400  
   Procedure to Check for Imbalance or Leaks 6A-010  
   Regulator Air Pressure Check 08-405  
   Supply Flat Belt Replacement/Adjustment 08-442  
   Supply Pulley Removal/Replacement 08-430  
   System, Description  
     Air Bearing 4A-160, 4B-160  
     Flow Diagram 4A-161, 4B-161  
     Pneumatic Switches 4A-160, 4B-160  
     Three-Way Valve 4A-160, 4B-160  
     Transfer Valve 4A-160, 4B-160  
     Transfer Valve Leakage Test 08-400  
     Transfer Valve Not Picked 2A-130  
 Pointer System  
   MAP 17-602  
   Pointer Register (Second Level) 53-045  
   Probe List (Table) 17-701  
   Timing Chart 17-702  
 Polarity Hold Drive (PHD) Register 6B-205  
 Possible 3420/3803 Problem Fix 00-050  
 Postamble Error (MAP) 17-190  
 Power  
   Cable 90-060  
   Check Indicator On 1A-000, 1B-000  
   Supply Checks (Installation) 90-180  
   Power-On Checks (Installation) 90-180  
   Power-On/Off Sequencing (Concepts) 40-003  
   Power On Reset 50-011  
   Reel Motor Voltages, Speed 3A-020, 3B-020  
   Requirements, Special-3420 Model 8 (Table) 90-180  
 Power Supplies  
   DC Checks/Adjustments 08-570  
   DC Test Points (3803/3420 Tables) 08-570  
   Modified 1A-002  
   Printed Circuit Board Removal/Replacement (3803 Model 2 Only) 08-575  
   TCU Power Supply Failure Analysis 11-000  
   Unmodified 1A-000, 1B-002  
   3420 1A-000, 1B-000  
   3420 Power Interface Board, B1 1A-003, 1B-001  
 Power Window  
   Alignment 08-640  
   Does Not Go Down 4A-140, 4B-140

Glass Removal/Replacement 08-670  
 Rack, Switch Adjustment 08-650  
 Safety Bail Adjustment 08-640  
 Safety Bail Cable Removal/Replacement 08-660  
 Preamps (see Adjustment)  
 Pressure, Air (see Pneumatic System)  
 Pressure Divider (CE Tool) 80-000  
 Pressure Test, Right Reel Latch  
 Rear Housing 08-520  
 Pressure/Vacuum Gauge 80-010  
 Preventive Maintenance  
   Fiber Optic Lamp Cleaning Procedure 08-260  
   General 85-000  
   Schedule 85-005  
   Tape Unit Cleaning Procedure 85-001  
 Priority, Select Out 90-120  
 Priority (2X16 Switch Logic) 58-060  
 Procedures  
   Capstan Motion Checks (Motion Appears Normal) 6B-020  
   Check for Tape Drag 6A-010  
   Diagnosing CE Panel Failure 12-020  
   Displaying Sense Information from CE Panel 12-012  
   Locating a Failing Command 12-010  
   Offline Duplication of Failures 12-000  
 Priority Circuits 54-020  
 Priority (see Selection and Priority)  
 Problems, Intermittent Drop Ready 2A-005  
 Proportional Drive Control, Capstan Motor (Second Level) 6B-215  
 Proportional Drive Counter (PDC) 6B-205  
 Protection, File (Concept) 40-001  
 Pulse Generator, Capstan 6A-120  
 Pushbuttons (see CE Panel Switches)

Q

Quick Fix Index, 3803-2 Subsystem 00-009

R

Radius Sensor Photo Cell 08-610  
 Read  
   Acceptable Waveforms (Read Card Test Points) 5B-004  
   Access Times (3420 Subsystem Characteristics) 40-002  
   Amplitude Adjustment (Model 4, 6, and 8) 08-310  
   Back Checking (Concept) 40-001  
   Backspace Operation 6B-230  
   Backward Command 40-005  
   Backward Operation 5A-140, 5B-140  
   Card Reference Generator 5B-120  
   Cycle Controls 53-095  
   Data Converter Data Flow Logic 57-026  
   Data Flow Logic 50-002  
   Data Flow Logic, NRZI 57-006  
   Errors, Permanent (see Permanent Read Error Analysis)  
   Forward to Backward Ratio Test (All Models) 08-240, 5B-020  
   Forward to Backward Ratio Test (Models 3, 5, 7) 5A-110

Forward Command 40-005  
 Forward Operation 5A-140, 5B-140  
 Head and Read Card Circuits 5B-120  
 Noise or Bits in the Interblock Gap 5A-115  
 Operation 5B-140  
 Register, A/B 53-055  
 Translator Data Flow Logic 57-021  
 VRC Indicator 75-004  
 6250 Service Requirements 50-030  
 Read Card Reference Generator 5B-120  
 Read Card Test Points (Table) 08-310  
 Read Electrical Skew Adjustment (NRZI Feature) 08-190  
 Read Head and Read Card Logic 5B-120  
 Read Only Storage (ROS) 6B-205  
 Read Only Tape Generation 90-200  
 Read Sequencing Circuits 53-055  
 Read/Write  
   Clocks and Counters (Table) 53-010  
   Clocks/Oscillators 53-005  
   CRC A, B, C, D 53-066  
   CRC Generators 53-065  
   Cyclic Redundancy Check Generation and Use 53-067  
   Data Flow Clock 53-015  
   Data Flow Logic 50-000, 50-001, 50-002  
   Envelope Failure, Runaway, or Read/Write Problems 5A-000, 5B-000  
   Head Degaussing and Resistance Check (Models 4, 6, and 8) 08-280  
   Head Resistance Check Procedure 5B-001  
   Intermittent Permanent Data Checks  
     Bit Packing 5A-115, 5B-025  
     Forward to Backward Ratio 5A-110, 5B-020  
     Noise or Bit In IBG 5A-115, 5B-025  
     Signal Dropout 5A-110, 5B-020  
     Tape Edge Damage 5A-110, 5B-030  
     Tape Slipping 5B-020  
     Tape Stretch 5A-115, 5B-020  
   Logic Circuits 5A-100, 5B-100  
   Problems 5A-000, 5B-000  
   Self Adjusting Gain Control (SAGC) 5B-120  
   Skew Detection 53-085  
   Vertical Redundancy Check (VRC) (Logic) 17-179  
   Vertical Redundancy Check (VRC) (MAP) (Chart) 17-168, 17-170  
   Vertical Redundancy Check (VRC) (Timing Charts) 17-172  
   VRC Circuit (Logic) 17-179  
   Write Clock and Write Counter 53-020  
   Write Head Card Plugging (Models 4, 6, and 8) 08-270  
   Write Service Controls 53-040  
   Zero Threshold 5B-120  
 Ready Lamp Does Not Turn Off 4A-100, 4B-100  
 Ready Lamp Does Not Turn On/Window Does Not Close 1A-210, 2B-210  
 Ready Symptoms Failure Chart 2A-000  
 Recording Methods/Formats  
   Concepts 40-002  
   Description 55-007  
   Interblock Gap (IBG) 40-002  
   Magnetic Tape and Reels (Concepts) 40-002  
   Nine-Track NRZI (Concepts) 40-002  
   PE (1600 BPI) Concepts 40-002

7-Track NRZI (Concepts) 40-002  
 6250 BPI (Concepts) 40-002  
 6250 BPI Error Correction (Concepts) 40-002  
 Reel  
   Alignment Tool Preparation Kit 08-460  
   Alignment Tool Modification/Zeroing 08-465  
   And Capstan Operations During Rewind 3A-030, 3B-030  
   Left Reel Does Not Turn Clockwise at Threading Speed 2A-110, 2B-110  
   Motors and Drivers 3A-020, 3B-020  
   Reel and Capstan Operations During Rewind 3A-030, 3B-030  
   Reel Does Not Stop 4A-130, 4B-130  
   Reel Motor and Hub Adjustment (CE Tools) 80-000  
   Reel Tachometers 3A-030, 3B-030  
   Rewind Operation and Timing Chart 3A-010, 3B-010  
   Right or Left Reel Won't Load Tape into Column 2B-180  
   Right Reel Does Not Stop 4A-130, 4B-130  
   Right Reel Does Not Turn Clockwise at Correct Speed 2A-120, 2B-120  
   Right Reel Latch Rear Housing Pressure Check 08-520  
   Stabilization 3A-020, 3B-020  
   Tachometer Removal/Replacement 08-550  
   Tachometers, During Rewind 3A-030, 3B-020, 3B-030  
   Tape Does Not Wind Completely Onto Right Reel 4A-130, 4B-130  
   Tape Fails to Go Backward 3A-130, 3B-130  
   Tape Unwinds Off Right Reel or TI Light Stays On 3A-150, 3B-150  
 Reference Charts, Device Switching Feature 18-029  
 Registers  
   A/B 53-055  
   Channel Tags and Bus In 52-040  
   Channel Write Byte 53-045  
   Crossovers 52-025  
   D 52-060  
   Dead Track 53-075  
   High and Low-Order ROS 52-035  
   Local Storage 52-015  
   MIST and TCS 52-060  
   MP1 and MP2 52-060  
   MP1/MP2 STAT 52-015  
   Pointer 53-045  
   ROS/LSR 52-015  
   Tape Unit Bus Out 52-045  
   Write Check 53-045  
 Regulator Air Pressure Checks/Adjustments 90-190, 08-405

INDEX 7

3803-2/3420

XK0400	2738034	See EC	845958	847298			
Seq 1 of 2	Part Number	History	1 Sep 79	15 Aug 83			

INDEX 7

**INDEX (Cont'd)**

Removals and Replacements  
 Air Bearings (D) 08-210  
 Autocleaner 08-370  
 Capstan Assembly (Non-90,000 Series) 08-020, 08-040  
 Capstan Assembly (90,000 series) 08-030, 08-050  
 Capstan Tachometer (Model 3, 5, 7) 08-110  
 Capstan Tachometer (Model 4, 6) 08-090  
 Cartridge Restraint 08-540  
 Cooling Fan 08-630  
 D-Bearing 08-210  
 Erase Head 08-250  
 Fiber Optics  
   BOT/EOT Block 08-590  
   Bundle 08-610  
   Lamp 08-620  
   LED BOT/EOT Block 08-590  
   LED BOT/EOT Window 08-590  
 Left Movable Guide and Retractor (NRZI Feature) 08-220  
 Left Reel Hub and Motor 08-560  
 Logic Panel (3420/3803) 08-630  
 Pneumatic Supply Flat Belt 08-442  
 Power Circuit Board (PCB) 08-575  
 Power Circuit Board (3803 Model 2 only) 08-575  
 Power Window Glass 08-670  
 Power Window Safety Bail Cable 08-660  
 Printed Circuit Board (3803 Model 2 Only) 08-575  
 Read/Write Head Card 08-260  
 Read/Write or Erase Head 08-250  
 Reel Tachometer 08-550  
 Right Rear Movable Guide and Retractor 08-210  
 Right Reel-Latch Rear Housing 08-470  
 Right Reel Motor 08-530  
 Right Reel Hub 08-480  
 Right Reel Hub Individual Parts 08-490  
 Vacuum Column Door Glass 08-690  
 Replacement  
   Cartridge Motor 08-535  
   Pneumatic Supply Flat Belt (Type 4) 08-442  
   Pneumatic Supply Pulley (All Types of Pneumatic Supplies) 08-430  
   Right Reel Hub 08-500  
   Right Reel Hub Individual Parts 08-490  
   Right Reel-Latch Rear Housing 08-510  
   Vacuum Column Door 08-680  
 Request In Interrupt 54-001  
 Request Track-In-Error Command 40-006  
 Reserve/Release Operation (TCS Feature) 58-011  
 Reset/Start or Step Switch (CE panel) 75-001  
 Resets (TCS Feature) 58-011  
 Resources PLAN 1  
 Response Chart 40-008  
 Rewind (REW)  
   Command 40-007  
   Concept 40-001  
   Operation and Timing Chart 3A-010, 3B-010  
   Problems 3A-000, 3B-000  
     Capstan Won't Rewind to LP After Loading Tape 2B-175  
     No Response or Tape Moves Backward 3A-100, 3B-100  
     Tape Does Not Enter or Stay in Hi Speed Rewind 3A-170, 3B-170  
     Tape Does Not Stop or Tape Runaway (Forward

or Backward) 3A-140, 3B-140  
 Tape Fails to Go Backward 3A-130, 3B-130  
 Tape Pulls Out Of or Dumps During High Speed Rew 3B-160  
 Tape Rewinds Off Left Reel 3B-180  
 Tape Rewinds to Beginning of Tape at High Speed 3A-170  
 Tape Stays in High Speed Rewind Status to Load Point 3B-180  
 Tape Unwinds off Right Reel 3A-150, 3B-150  
 Unload/Rewind Pushbutton (No Response) 4A-110, 4B-110  
 Wide Excursions in Left Column During High Speed Rewind 3A-160, 3B-160  
 Rewind Times (Subsystem Characteristics) 40-002  
 Rewind/Unload (RUN)  
   Command 40-007  
   Concepts 40-001  
   Unload Operation With Cartridge 4A-000, 4B-000  
   Unload Operation Without Cartridge 4A-000, 4B-000  
   Problems 4A-000, 4B-000  
     Cartridge Opener Does Not Close 4A-150, 4B-150  
     No Response When Rewind/Unload Button is Pressed 4A-110, 4B-110  
     Power Window Does Not Go Down 4A-140, 4B-140  
     Reels Do Not Stop 4A-130, 4B-130  
     Tape Does Not Pull Out of Columns Properly During Unload Rewind 4A-120, 4B-120  
     Tape Does Not Wind Completely onto Right Reel or Reels Does Not Stop 4A-130, 4B-130  
     Tape Moves Backward Off Left Reel 2B-190  
     Tape Unit Performs a Normal Unload Rewind During a Load Operation 2B-190  
     Unload Rewind Pushbutton (No Response) 4A-110, 4B-110  
 Rewind/Unload Times (Subsystem Characteristics) 40-002  
 RIC/ROC 53-080  
 Right Reel  
   Does Not Turn Clockwise at Correct Speed 2A-120, 2B-120  
   Hub Individual Parts Replacement 08-490  
   Hub Removal 08-480  
   Hub Replacement/Adjustment 08-500  
   Latch  
     Rear Housing Pressure Test 08-520  
     Rear Housing Removal 08-470  
     Rear Housing Replacement 08-510  
   Logic 3A-030, 3B-030  
   Motor Removal/Replacment 08-530  
   Motor Speed, Voltages 3A-020, 3B-020  
   Reels Do Not Stop 4A-130, 4B-130  
   Right or Left Reel Won't Load Tape into Column 2B-180  
   Tape Does Not Wind Completely onto Right Reel 4A-130, 4B-130  
   Tape Unwinds Off Right Reel or TI Light Stays On 3A-150, 3B-150  
   Theory, Rewind and Timing Chart 3A-010, 3B-010  
   Won't Load Tape into Column 2B-180  
 Right Threading Channel 08-230  
 Ripple/Wr Data Switch (CE Panel) 75-002  
 ROS Bit P1, 0-7 Test Points (Table) 16-020

ROS Bit P2, 8-15 Test Points (Table) 16-010  
 ROS Mode Switch (CE Panel) 75-002  
 ROS Patch Card (Plugging) 80-030  
 ROS 1 Trap Conditions Logic 50-010  
 Routines, Linking Microprogram 52-030  
 Rules and Definitions, Device Switching 18-011  
 Runaway  
   Envelope Failure, Runaway, or R/W Problems 5A-000, 5B-000  
   Tape Does Not Stop or Tape Runaway (FWD/BKWD) 3A-140, 3B-140

**S**

Safety Section  
 SAGC (Self-Adjusting Gain Control)  
   Check 16-220  
   Theory 5B-120  
 Scale (CE Tool) 80-000  
 Schematics  
   IBG Counter (Model 3, 5, 7) 6A-130  
   Microprocessor (MP1, MP2) Flow 50-003  
   Read/Write Flow 50-000, 50-001, 50-002  
   ROS 1 Trap Conditions 50-010  
 Scoping Permanent Errors  
   Offline 00-013  
   Online 00-014  
 Select In/Select Out 54-020  
 Select Out Priority (Table) 90-120  
 Selection, Tape Control and Tape Unit 54-005  
 Selection (TCS Feature) 58-011  
 Selection and Priority 54-010  
 Selective Reset 50-011  
 Self-Adjusting Gain Control and Zero Threshold 5B-120  
   Logic 1x8 18-000  
   Priority Circuits 54-020  
   Tape Control and Tape Unit Addressing 54-005  
   Tape Control and Tape Unit Selection 54-005  
   Tape Unit Selection 54-010  
 Sense  
   Analysis (MAP) 14-000  
   Analysis, Error Correction (MAP) 21-000  
   Bytes 0-23  
     Bits not Defined in MAPs 00-006  
     Tables 00-005  
   Mask for Sense Data After Rewind 15-140  
   Subsystem Quick Fix Index, Sense Byte Analysis 00-009  
   Tape Unit Sense Bytes (Table) 00-005  
   Sense All Zeros (MAP) 15-080  
   Sense Byte to Bit Conversion (Table) 14-005  
   Sense Byte 3, Bit 4 17-315  
   Sense Byte 5, Bit 5 17-410  
   Sense Command 40-005  
   Sense Data Equals All Zeros 15-080  
   Sense Release Command (TCS Feature) 40-006, 58-011  
   Sense Reserve Command (TCS Feature) 40-005, 58-011  
   Sensor Adjustment, AMP (NRZI-Model 3, 5, 7) 08-300  
   Sensor Adjustment, AMP

(PE Only-Model 3, 5, 7) 08-290  
 Sequence Chart, Forward Creep During Rewrite 6B-230  
 Sequencing, Power On/Off (Concepts) 40-003  
 Service Controls, Write 53-040  
 Service In/Service Out 58-005  
 Service Out Inactive During Reset or Power-On-Reset (MAP) 13-350  
 Service Out Tag Active (MAP) 13-280  
 Service Requirements  
   6250 Read 50-030  
   6250 Write 50-020  
 Set Diagnose Command 40-006  
 Set ROS Mode/Set CE Compr Switch (CE Panel) 75-002  
 Seven-Track NRZI Recording (Concepts) 40-002  
 Shim (CE Tool) 80-000  
 Short Cycle XFR Example (Timing Chart) 16-001  
 Short Gap (with Tape Damage) 00-012  
 Signal Dropout 5A-110, 5B-020  
 SIO Trap Failures (MAP) 13-320  
 Single Tape Unit Problems Chart 00-040  
 Skew  
   Buffers 53-075  
   Detection 53-085  
   Error 17-166  
   Error Circuit Description 17-166  
   Errors, Test Point Chart (Table) 17-162  
   Error Timing Chart 17-163  
   Group Buffer Counter 53-090  
   Indicator (CE Panel) 75-004  
   RIC Equals ROC (MAP) 17-160  
   Test Points, Skew Errors (Chart) 17-162  
 Slippage, Tape 5B-020  
 Slow End Readback Check (MAP) 17-150  
 Solenoid Check, High-Speed Rewind 08-405  
 Space Block Commands (Description) 40-007  
 Space File Commands (Description) 40-007  
 Special Power Requirements-3420 Model 8 (Table) 90-180  
 Special Register, MP1 (Hardware Errors) 52-060  
 Special Register, MP2 (TU Bus In) 52-060  
 Stack Interrupt (TCS Feature) 58-012  
 Stack/Stack Interrupt (TCS Feature) 58-012  
 Standard Voltages, Definition of 00-003  
 Start Capstan Motion 6B-220  
 Start I/O (SIO) Routine, Common 55-020  
 Start Problem Analysis START 1  
 Start Read Check (MAP) 17-070  
 Start Times, Forward (Subsystem Characteristics) 40-002  
 Stat Registers 52-015  
 Status Byte Chart 00-005  
 Status Reject, Command or Control 6A-160  
 Stop Address-FRU List (Table) 16-060  
 Stop On Control Check Switch (CE Panel) 75-001  
 Stop On Data Flow Check Switch (CE Panel) 75-001  
 Stop/Start Switch (CE Panel) 75-002  
 Store (ALU Operation) 52-095

3803-2/3420

XK0400	2736034	See EC History	845958	847298				
Seq 2 of 2	Part Number		1 Sep 79	15 Aug 83				

**INDEX 8**

**INDEX 8**



Subsystem  
 Address/Feature/Priority Card Plugging 90-110  
 Cabling 90-060  
 Channel Cable Maximum Length for  
 6250 BPI (Table) 90-070  
 Channel Attachment (Table) 90-010  
 Concepts 40-002  
 Configuration 90-100  
 Configuration Worksheet Instructions 90-030  
 Device Switching 90-050  
 Error Correcting/Detecting Code 40-002  
 External Cables (Table) 90-070  
 Field Tester Conversion 90-170  
 Installation Checklist (3803-2/3420) 90-020  
 Installation (Introduction/Instructions) 90-000  
 Kickplates 90-100  
 Power Cable 90-060  
 Power Supply Checks 90-180  
 Quick Fix Index, 3803-2 00-009  
 Recording Method 40-002  
 Unpacking Instructions 90-000  
 3803/3420 Configurations 40-003  
 Suppress Out Active (MAP) 13-310  
 Suppress Out Inactive During Reset or  
 Power-On-Reset (MAP) 13-340  
**Switches**  
 Cartridge Open and Closed 2A-100, 2B-100  
 CE Panel 75-001  
 Vacuum Column 08-450  
**Switching Configuration, Device** 58-050  
**Symbols and Legend** PLAN 4  
**Symptoms**  
 Capstan Motion Failure 6B-000  
 Dropping Ready and Thread and Load Failure  
 2A-000, 2B-000  
 Failure Follows Tape Unit 00-040  
 Index, 3420/3803 00-010  
 Unload 4A-000, 4B-000  
 Tape Motion and Rewind Chart 3A-000, 3B-000  
 3803/3420 Index 00-010  
 System Diagnostics (Installation) 90-200  
 System/360/370 Switching 58-005

**T**

TACH Period Counter (TPC) 6B-205  
 TACH Start Failure (Sense Byte 10, Bit 5)  
 (MAP) 16-170  
 TACH Velocity Error (MAP) 13-510  
 Tachometer, Capstan (Model 3, 5, 7) 08-130  
 Tachometer, Capstan (Model 4, 6, 8) 08-120  
 Tachometer, Reel 3B-020, 3B-030  
 Tags In Register, Channel 52-040  
 Tape Cleaning Kit (CE Tool) 80-000  
 Tape Cleaner (see Autocleaner)  
**Tape Control (TCU)**  
 Addressing 40-003  
 Address Decoders 58-010  
 Address/Feature/Priority Card 90-110  
 Branch To Read From Load Point 55-040  
 Branch To Write From Load Point 55-024  
 Channel Interface Problems (Table) 18-040  
 Common Start I/O (SIO) 55-020  
 Concepts 40-003  
 Configurations (Concepts) 40-003

Contingent Connection (TCS Feature) 58-012  
 Control Unit End (TCS Feature) 58-012  
 Density Feature Configurations 40-004  
 Device End (TCS Feature) 58-012  
 Device Switching Feature 54-010  
 Enable/Disable Switch 40-003  
 Group Coded Recording (GCR) 55-008  
 Interface Switch Control 58-011  
 Logic Panel Card Plugging 19-000  
 Logic Panel Removal/Replacement 08-630  
 Loop-Write-To-Read (LWR) 55-005  
 MAPs (see MAPs)  
 Metering 40-003  
 Metering Problems (MAP) 18-060  
 Online and Offline Status 40-003  
 Power On/Off Sequencing (Concepts) 40-003  
 Registers 52-060  
 Channel Tags and Bus In 52-040  
 Crossovers 52-025  
 D 52-060  
 High and Low-Order ROS 52-035  
 Local Storage 52-015  
 MP1 and MP2 52-060  
 MP1/MP2 STAT 52-015  
 ROS/LSR 52-015  
 Tape Unit Bus Out 52-045  
 Resets (TCS Feature) 58-011  
 SDI Logic! (Table) 18-030, 18-032  
 Selection and Addressing 54-005  
 Sense Byte Bits Not Defined in MAPs 00-007  
 Sense Byte Chart 00-005  
 Sequencing, Power On/Off 40-003  
 Stack Interrupt (TCS Feature) 58-012  
 Status Byte Chart 00-005  
 Tie Breaker Logic 58-010  
 Timing, Read Cycle Controls 53-095  
 Tape Control To/From Device (Chart) 18-005  
 Tape Crimper Procedure 2A-015, 2B-006  
**Tape Damage**  
 Analysis of IBG in Developed Tape 00-013  
 At End of Block (Block Appears Short) 00-012  
 Consists of Small Spot or Oxide Void (1 or  
 More Tracks) 00-012  
 Edge Damage 5B-030  
 In Beginning Zeros Burst (PE Only) 00-012  
 In Ending Zeros Burst (PE Only) 00-012  
 In Erased Gap Area 00-012  
 In Middle of Data 00-012  
**Scope**  
 Offline 00-013  
 Online 00-014  
 Short Gap 00-012  
**Tape Developing Procedure** 00-011  
 Tape Guide Check (NRZI-Featured Units) 08-230  
 Tape Slippage 5B-020  
 Tape Speed (3420 Characteristics) 40-002  
 Tape Subsystem Cabling, Device Switch  
 Feature 18-011  
 Tape Transport Cleaner (CE Tool) 80-000  
**Tape Unit**  
 Autocleaner Operation 40-001, 5B-110,  
 08-360  
 Bus In Test Points (Table) 17-312  
 Bus Out Test Points (Table) 17-312  
 Characteristics Table 40-002  
 Commands 40-006

Commands and Command Status Byte (Table)  
 16-164  
 Control Lines Charts 16-213  
 Double Track Errors 40-002  
 EC Level 90-210  
 Erase Head 5B-110  
 Feature Code 90-210  
 Full Width Erasure 40-001  
 General and Daily Cleaning 85-000  
 Ground Check 08-600  
 Head-Mirror Stop Adjustment (Model 3, 5, 7)  
 08-350  
 IBG Counter (Model 3, 5, 7) 6A-130  
 Initial Selection 54-000  
 Initiating Tape Motion 07-010  
 Interchangeability Problems 40-001  
 Logic Panel Card Plugging (Models 3, 5, and 7)  
 19-010  
 Logic Panel Card Plugging (Models 4, 6, and 8)  
 19-011  
 Logic Panel Removal/Replacement 08-630  
 Loop-Write-To-Read 55-005  
 Model Number 90-212  
 Online/Offline Switches (2X8 Switching)  
 58-080  
 Power Supplies 1A-000, 1B-000  
 Problems, Single Unit 00-040  
 Selection and Addressing 54-005  
 Selection Priority 54-010  
 Sense Byte Chart 00-005  
 Serial Number 90-210  
 Single Direct-Drive Capstan 40-001  
 Single Track Errors 40-002  
 Speed (Subsystem Characteristics) 40-002  
 Tape Developing Analysis 00-011  
 Tape Guide Check (NRZI Feature) 08-230  
 Track Pointers 40-002  
 Two-Gap Read/Write Head 40-001  
**Tape Unit Problems**  
 Bit Packing 5A-115, 5B-025  
 Capstan Starts Turning When Power is Turned  
 On (Second Level) 6B-140  
 Dropping Ready and Thread and Load Failure  
 Symptoms 2A-000, 2B-000  
 Capstan Fails to Start a Rewind to Load  
 Point After Loading Tape into Columns 2B-175  
 Cartridge Does Not Open 2A-100, 2B-100  
 Intermittent Drop Ready 2A-005, 2B-005  
 Left or Right Vacuum Column Problems  
 2A-170, 2B-170  
 Left Reel Does Not Turn Clockwise at  
 Threading Speed 2A-110, 2B-110  
 Load Check Prior to BOT Sense 2A-150,  
 2B-150  
 Ready Lamp Does Not Turn On/Window  
 Does Not Close 2A-210, 2B-210  
 Right or Left Reel Fails to Load Tape  
 into Columns 2B-180  
 Right Reel Does Not Turn Clockwise at  
 Threading Speed 2A-120, 2B-120  
 Tape Does Not Go Backward or Does  
 Not Stop at BOT 2A-190  
 Tape Does Not Load into Either Column  
 2A-160, 2B-160

Tape Goes Forward After Loading into  
 Vacuum Columns 2A-200, 2B-200  
 Tape Motion Problems (Stubby Column  
 Loops) 6A-010  
 Tape Moves Backward Off Left Reel, or Tape  
 Unit Performs a Normal Unload Rewind During  
 a Load Operation 2B-190  
 Tape Starts into Threading Channel and  
 Stops 2A-140, 2B-140  
 Tape Threads into Right Column 2A-130,  
 2B-130  
 Forward to Backward Ratio 5A-110, 5B-020  
 Intermittent Drop Ready 07-010  
 Noise or Bit in IBG 5A-115, 5B-025  
 Permanent Data Checks (MAP) 5A-105, 5B-002  
 Signal Dropout 5A-110, 5B-020  
 Tape Drag Check 6A-010, 6B-150  
 Tape Edge Damage 5A-110, 5B-030  
 Tape Motion Symptoms 3A-000, 3B-000  
 Left or Right Vacuum Column-Tape Pulls Out,  
 Bobbles, Bottoms 3A-110, 3B-110  
 No Response or Tape Moves Backward  
 3A-100, 3B-100  
 Tape Does Not Enter or Stay in High Speed  
 Rewind or Rewinds to BOT at High Speed  
 3A-170, 3B-170  
 Tape Does Not Stop or Tape Runaway (Forward/  
 Backward) 3A-140, 3B-140  
 Tape Fails to go Backward 3A-130, 3B-130  
 Tape Has Wide Excursions in Left Column  
 During High Speed Rewind 3A-160, 3B-160  
 Tape Pulls Out or Dumps in Left Column  
 During HS Rew 3A-160, 3B-160  
 Tape Rewinds to Beginning-Of-Tape (BOT) at  
 High Speed 3A-170, 3B-170  
 Tape Unwinds Off Right Reel 3A-150, 3B-150  
**Tape Slipping** 5B-020  
**Tape Stretch** 5A-115, 5B-020  
**Tape Unit Check (MAP)** 15-090  
 Tape Unit Loads but Capstan Motion is Faulty  
 (MAP) 6B-110  
 Tape Wont Thread, Load, and Return to BOT  
 Properly (MAP) 6B-100  
**Unload Failure Symptoms**  
 Cartridge Opener Does Not Close 4A-150,  
 4B-150  
 Pneumatic Motor Does Not Turn Off 4A-160,  
 4B-160  
 Power Window Does Not Go Down 4A-140,  
 4B-140  
 Ready Lamp Does Not Turn On 4A-100, 4B-100  
 Tape Does Not Pull Out of Columns Properly  
 During Unload Rewind 4A-120, 4B-120  
 Tape Does Not Wind Completely Onto Right  
 Reel or Reels Do Not Stop 4A-130, 4B-130  
 Unload Rewind Pushbutton (No Response)  
 4A-110, 4B-110  
 TB-1, TB2, and TB3 Diagram 1A-002  
 TCS (see Two Channel Switch)  
 TCU (see Tape Control)  
 Technique, Card Isolation PLAN 1  
 Tee and Hose Assembly (CE Tool) 80-000  
 Terminator and Cable Plugging 90-060  
 Terminology Notes PLAN 1

3803-2/3420

XK0500	6851776	847298						
Seq 1 of 2	Part Number	15 Aug 83						

# INDEX (Cont'd)

Test I/O Instruction 40-009  
 Test Points, Channel Buffer/Write Bus (Table) 17-021  
 Test Points (Read Card) 5B-004  
 Tester, CE (see Field Tester)  
 Theory (see Tape Unit or Tape Control Unit)  
 Theory (TCS Feature) 5B-010  
 Theory of Operation  
   Additional Stopping Distances After Go Extend 6A-140  
   Air Bearings 4A-160, 4B-160  
   Airflow and Voltage Monitoring System 1A-000, 1B-000  
   Backspace 6B-230  
   Capstan Control Circuits 6A-120, 6B-020  
   Capstan Drive System 6A-120, 6B-200  
   Capstan Motion Checks 6A-000, 6B-000  
   Capstan Motor and Controls 6A-120, 6B-020  
   Capstan Pulse Generation 6A-120, 6B-200  
   Cartridge Opener Does Not Close 4A-150, 4B-150  
   Data Exchange on DEVI During Write Operation 5A-130, 5B-130  
   Erase Head (Schematic) 5B-110  
   Extended Go 6B-205  
   Go Extend IBG Counts 6A-140  
   Go Extensions in Quarter TACH Pulses 6B-205  
   IBG Counter Circuits 6A-130, 6B-205  
   IBG Generation 6A-150, 6B-210  
   Left or Right Vacuum Column Problems 3A-110, 3B-110  
   Left Reel Does Not Turn Clockwise at Threading Speed 2A-110, 2B-110  
   Load Check Prior to BOT Sense 2B-150  
   Major Elements of Capstan Control Logic 6B-205  
   Plugging (Model 7 Only) 6A-140  
   Pneumatic System (flow diagram) 4A-160  
   Pneumatic Switches 4A-160, 4B-160  
   Polarity Hold Drive (PHD) Register 6B-205  
   Power Check 1A-000, 1B-000  
   Power Supplies 1A-000, 1B-000  
   Proportional Drive Counter (PDC) 6B-205  
   Read Backward Operation 5A-140, 5B-140  
   Read Card and Read Card Circuits 5B-120  
   Read Card Reference Generator 5B-120  
   Read Forward Operation 5A-140, 5B-140  
   Read Only Storage (ROS) 6B-205  
   Reel and Capstan Operations During Rewind 3A-030, 3B-030  
   Reel Drive System Schematic 3A-020, 3B-020  
   Reel Motors and Drivers 3A-020, 3B-020  
   Reel Stabilization 3A-020, 3B-020  
   Reel Tachometers 3B-020, 3B-030  
   Reel Tachometers, During Rewind 3A-030, 3B-030  
   Reset/Start or Stop Switch 75-001  
   Rewind Operation 3A-010, 3B-010  
   Self Adjusting Gain Control (SAGC) 5B-120  
   TACH Period Counter (TPC) 6B-205  
   Three-Way Valve 4A-160, 4B-160  
   Transfer Valve 4A-160, 4B-160  
   Unload Operation with Cartridge 4A-000, 4B-000  
   Unload Operation without Cartridge 4A-000, 4B-000  
   Write Head, Erase head, and Write Card (Schematic) 5B-110  
   Zero Threshold 5B-120  
   6 MHz Oscillator and GCC 6B-205

3420 Power Supplies 1A-000  
 Thread and Load Operations 2A-010, 2B-020  
 Thread, Load  
   Check Points 2A-020, 2B-030  
   Checking with Cartridge (Timing Chart) 2A-010, 2B-020  
   Checking without Cartridge (Differences) 2A-020, 2B-030  
   Failure Symptoms 2A-000, 2B-000  
   Left Reel Turns Too Fast 2A-110, 2B-110  
 Operations  
   Cartridge Does Not Not Open 2A-100, 2B-100  
   Left or Right Vacuum Column Problems 2A-170, 2B-170, 3A-110, 3B-110  
   Left Reel Does Not Turn Clockwise at Threading Speed 2A-110, 2B-110  
   Load Check Prior to BOT Sense 2A-150, 2B-150  
   Motor Not Running or Transfer Valve Not Picked 2A-130, 2B-130  
   Ready Light Does Not Turn On 2A-210, 2B-210  
   Right Reel Does Not Turn Clockwise at Correct Speed 2A-120, 2B-120  
   Tape Does Not Go Backward or Does Not Stop at BOT 2A-190  
   Tape Does Not Load into Either Column 2A-160, 2B-160  
   Tape Enters Threading Channel and Stops 2A-140, 2B-140  
   Tape Goes Forward after Loading into Vacuum Columns 2A-200, 2B-200  
   Tape Unit Won't Thread, Load, and Return to BOT Correctly 6B-100  
   Time Required in Execute (Subsystem Characteristics) 40-002  
   Regulator Air Pressure Check 08-400  
   Threading Vacuum Check 08-400  
   Transfer Valve Leakage Test 08-400  
   Thread Load Checking With Cartridge 2A-020, 2B-030  
   Thread Load Without Cartridge (Differences) 2A-020  
   Thread Status Active and Inactive 4A-161, 4B-161  
   Threading Failure Symptoms Chart 2A-000, 2B-000  
   Three Control Switch Feature (Concepts) 5B-050  
   Three-Way Valve 4A-160, 4B-160  
   TIE Breaker (with TCS Feature) 5B-012, 5B-030  
   TIE (Request Track-in-Error Command) 40-006  
 Timing Chart  
   Bit Cell and PE and NRZI Write Waveform 55-007  
   Branch Unconditional 52-090  
   Byte Count or Go Down 12-028  
   CE Entry 12-027  
   Clock 17-800  
   Command Select Sequencer and Decoder 12-026  
   Command Sequence (Tag Lines/Status) 54-001  
   Cyclic Redundancy Check (CRC) 17-544, 17-545, 17-546  
   Data Convert Write Timing 57-025  
   Go Extend IBG 6A-140  
   IBG Generation 6B-210  
   Long Cycle (BOC or BU) 16-001  
   Microprocessor Clocks Control 52-005  
   NRZI R/W VRC, Hi Clip VRC, LRC Errors 17-314  
   Ovrrun 15-041  
   PE 17-176  
   PE Mode 17-016, 17-025, 17-111

PE Write 17-165  
 Plugging Reverse High Power Current (Model 7 Only) 6A-140  
 Pointer System, PE 17-705  
 Pointer System, 6250 17-702  
 Read Cycle Controls 53-095  
 Read Electrical Skew 08-190  
 Rewind 3A-010, 3B-010  
 Set and Display CE Register 12-021  
 Set and Display Compare Register 12-022  
 Short Cycle (XFR) Example 16-001  
 Start Capstan Motion (Write Operation 200 IPS) 6B-220  
 Store 52-095  
 Thread and Load 2B-020  
 Thread Load Checking With Cartridge 2A-020, 2B-030  
 Thread Load With Cartridge 2A-010  
 Transfer 52-100  
 Write Electrical Skew (NRZI Feature) 08-200  
 6250 BPI Mode 17-014, 17-015,  
 6250 Multi-Track Error (MTE) 17-111  
 6250, PE, and NRZI Waveform 53-070  
 6250 Read Service Requirements 50-030  
 6250 Write 17-172  
 6250 Write (RIC/ROC) 17-163  
 6250 Write Service Requirements 50-020  
 6250 Write Trigger VRC 17-022  
 7-Track 17-313  
 Timing Charts, Used in MAPs (Description) 00-003  
 Tools and Test Equipment 80-000  
 Transfer (ALU Operation) 52-100  
 Transfer Decodes, Microprogram (MP1 and MP2) 52-101  
 Transfer Valve  
   Not Picked or Pneumatic Motor Not Running 2A-130, 2B-130  
   Leakage Test 08-400  
 Translation  
   Write Translator 7-Track 57-020  
   Read Translator 7-Track 57-021  
 Translator, Write 57-020  
 Transport Cleaning Procedure 85-001  
 Transport Concepts 40-001  
 Transport, Tape (Concept) 40-001  
 Trap Channel A/B (TCS Feature) 58-011  
 Trap Condition Schematic, ROS 1 50-010  
 Troubleshooting Procedure, Device Switching (MAP) 18-020  
 TU (see Tape Unit)  
 TU Bus In (MP2 Special Register) 52-060  
 TU Control Lines and Control Status Byte Response (Table) 16-213  
 TUBI Test Points (Table) 17-312  
 TUBO Test Points (Table) 17-312  
 Two Channel Switch (TCS) Feature 58-010  
   TCS or MIST Register (MP1) 52-060  
 Two Control Switch Feature (Concepts) 58-050  
 Type 2272 MST Card Adjustment 17-800  
 Typical Flow Through MAPs (Example) 00-002

## U

U Pgm Indicators 75-004  
 Unit Check Without Supporting Sense or Unexpected Sense (MAP) 15-100  
 Unload Operation With/Without Cartridge 4A-000, 4B-000  
 Unload Operations (see Rewind/Unload Operation)  
 Unmodified Power Supply, 3420 1A-000, 1B-002  
 Unpacking Instructions, Subsystem Installation 90-000

## V

Vacuum Column  
   Balance 08-800  
   Door Glass Removal/Replacement/Adjustment 08-690  
   Door Replacement/Adjustment 08-680  
   Left or Right Vacuum Column Problems 2A-170, 2B-170, 3A-110, 3B-110  
   Switch Check 08-450  
   Tape Bobbles Vacuum Columns 3A-110, 3B-110  
   Tape Bottoms in Vacuum Columns 3A-110, 3B-110  
   Tape Does Not Load into Either Column 2A-160, 2B-160  
   Tape Exhibits Abnormal Motion Symptoms 3A-110, 3B-110  
   Tape Goes Forward After Loading into Vacuum Columns 2A-200, 2B-200  
   Tape Pulls Out of Vacuum Columns 3A-110, 3B-110  
   Wide Excursions in Left Column During High Speed Rewind 3A-160, 3B-160  
 Vacuum Chart ((Inches of Water) All Models) 08-405  
 Vacuum Level Adjustment, Altitude 08-410  
 Vacuum/Pressure Gauge (Setup) 80-010  
 Valid Pointers 17-602  
 Variable Go-Down Time 40-006  
 Velocity Check, Velocity Change During Write 16-180  
 Voltage and Airflow Monitoring System 1A-000, 1B-000  
 Voltage Levels (Limits) 00-003  
 Voltages, Standard (Definition Of) 00-003  
 VRC Error, Write Trigger 17-020  
 VRC, Write Trigger Circuit Description 17-026

## W

Water Manometer (Procedures) 80-010  
 Waveforms (Read Forward and Backward Ratio Test) 5A-110, 5B-020  
 Wide Excursions in Left Column During High Speed Rewind 3A-160, 3B-160  
 Window (see Power Window)  
 Word Count Zero (MAP) 15-050

3803-2/3420

XK0500	6851776	847298							
Seq 2 of 2	Part Number	15 Aug 83							

© Copyright International Business Machines Corporation 1983

# INDEX 10

**INDEX (Cont'd)**

**Write**  
 Access Times (Subsystem Characteristics) 40-002  
 Byte Counter 53-025  
 Byte Register, Channel 53-045  
 Check Register 53-045  
 Clock and Write Counter 53-020  
 Command 40-005  
 Data Converter Logic 57-025  
 Data Exchange on Device Interface During Write Operation 5A-130, 5B-130  
 Data Flow Logic 50-000, 50-001  
 Electrical Skew Adjustment (NRZI Feature) 08-200  
 Enable Ring (see File Protection-Concepts)  
 Forward Creep During Write 6B-230  
 Group Buffer Control 53-025  
 Head Card Plugging (Models 4, 6, and 8) 08-270  
 Service Controls 53-040  
 Tape Mark (WTM) Check (MAP) 17-180  
 Tape Mark Command 40-007  
 Translator, 7-Track Logic 57-020  
 Trigger Operation, 6250, NRZI, and PE 53-070  
 Write Trigger Indicator 75-004  
 Write Trigger Vertical Redundancy Check (VRC) Logic 17-026  
 Error (MAP) 17-020  
 Error, 6250 BPI (Timing Chart) 17-022  
 Write Current Failure or Tape Unit Check (MAP) 15-090  
 Write Head, Erase Head, and Write Card Circuits 5B-110  
 6250 Write Operation (MAP) 13-480  
 6250 Service Requirements 50-020

**X**

XOUTA Register Not Functioning (MAP) 13-430  
 XLOUTA/XOUTB (Crossover) Registers 52-025

**Y**

Y1 Panel Location 90-080

**Z**

Zero Threshold 5B-120

**NUMERIC**

1 and 2 Track 6250 Error Correction 17-600  
 301 Trap Address, TCS or Device Switching Without TCS (MAP) 13-240  
 360/370 Switching Logic 58-005  
 1600 BPI (Concepts) 40-002  
 3420  
 Airflow and Voltage Monitoring System 1A-000, 1B-000  
 Altitude Vacuum Level Adjustment 08-410  
 Daily and General Cleaning Instructions 85-000  
 Dropping Ready, Thread, and Load Failure Symptoms 2A-000, 2B-000  
 Field Tester Accuracy Check 08-290, 08-300, 08-315  
 Field Tester Procedure 80-020

Installation Checklist 90-020  
 Models 3-8 Cleaning Procedure 85-001  
 Model 8-Special Power Requirements 90-180  
 Modified Power Interface Board (B1) 1A-003  
 Modified Power Supply 1A-002  
 Preventative Maintenance Schedule 85-005  
 Read Amplitude Adjustment 08-310  
 SAGC Checks 08-315  
 Tape Speed (3420 Subsystem Characteristics) 40-002  
 Unmodified Power Supply 1A-000  
**3803**  
 CE Panel Description 75-001  
 Installation Checklist 90-020  
**3803/3420 Magnetic Tape Subsystem 40-001**  
 Basic Sense Data 40-001  
 Command Set 40-001  
 Cross-Reference, Pins To Logic 17-166  
 Features (Concepts) 40-004  
 Logic Panel Removal/Replacement 08-630  
 Preventative Maintenance Schedule 85-005  
 Status Pending 13-220  
 Status Response 40-001  
 Symptom Index 00-010  
 Tape Control (Concepts) 40-003  
 6250 Write Operation (MAP) 13-480  
 PE Mode Timing Chart 17-016  
 1x8 Selection Logic (MAP) 18-000  
 2 Control Switch (Concepts) 58-050  
 2x8 Switch Logic 58-055  
 2x8 Switching Functional Units 58-080  
 2x16 Switch Logic 58-060  
 3 Control Switch (Concepts) 58-050  
 4 Control Switch (Concepts) 58-050  
 4x16 Switch Logic 58-070  
 6 MHz Oscillator and Gray Code Counter 6B-205  
 6250 BPI  
 (Concepts) 40-002  
 Error Correction (Concepts) 40-002  
 Mode Timing Chart 17-014, 17-015  
 PE CRC 17-540  
 6250 Error Correction (MAP) 17-600  
 6250 Read Service Requirements 50-030  
 6250 Stress Tape (CE Tool) 80-000  
 6250 Write Service Requirements 50-020  
 7-Track NRZI Threshold Adjustment Card 80-000  
 7-Track Timing Chart 17-313  
 7 or 9 Track LRC 17-310  
 7 and 9 Track NRZI 40-004  
 9-Track CRC Generation During Read and Write 53-067

**3803-2/3420**

XK0600	6851777	847298						
Seq 1 of 2	Part Number	15 Aug 83						

3803-2/3420

XK0600	6851777	847298							
Seq 2 of 2	Part Number	15 Aug 83							

© Copyright International Business Machines Corporation 1983

