



3725

Communications
Controller



The photo of a design model shows:
a 3275 model 1 base frame
a 3276 expansion frame
a 3277 operator console

PRODUCT DESCRIPTION

The 3275 is a modular, programmable communication controller running under control of either Network Control Program (ACF / NCP V2), Emulation Program (EP / V4) or Partitioned Emulation Program (PEP).

It communicates with the access method located in IBM S/370, 303x, 43xx, 308x CPU types connected locally by a channel attachment or remotely through a local 3275 or 370x.

Coexistence of 370x and 3275 in the same network is possible.

A 3275 allows attachment of lines either half or full duplex using synchronous or asynchronous protocols. Speed range is from 50 bps to 256 Kbps.

The 3275 is available with 3 storage sizes.

The communication controller is packaged in two units:

- The 3275 basic frame which houses the Central Control Unit (CCU), the storage, the Maintenance and Operator Sub-System (MOSS), Channel Adapters (C.A.), Communication Scanner Processors (CSP);
- The 3276 expansion frame offers optional channel adapters and communication scanner processors.

A keyboard display terminal provides CE and operator access to the 3275 and 3276 under control of the MOSS.

The controller structure is improved over the 370x:

- One channel adapter type
- One communication scanner type
- Only five types of line attachments.

Power requirements: 200/240 V single phase 50/60 Hz AC power.

The 3275 has a performance of 1.8 to 3.5 times over 3705 depending on configurations. CCU storage read only cycle: 400 ns, read-write cycle: 600 ns.

Communication scanner scanning capability: 307.2Kbps.

IBM INTERNAL USE ONLY



The photo of a design model shows:

a 3725 model 1 base frame

a 3726 expansion frame

a 3727 operator console

GENERAL CHARACTERISTICS

All 3725 models contain:

- CONTROL SUB SYSTEM (CSS)
- TRANSMISSION SUB SYSTEM (TSS)
- MAINTENANCE AND OPERATOR SUB SYSTEM (MOSS)

CONTROL SUB SYSTEM (CSS)

- CCU
 - 370x instruction set
 - 2 new instructions (Communication with channel adapters and scanners)
 - 5 program levels
 - 22 bit registers
 - Enhanced storage protect mechanism
 - Input Output Control (IOC), Maintenance Input Output Control (MIOC) and their associated bus.
 - Branch trace and address compare facilities
- Storage
 - Error checking and correction
- Channel Adapters (C.A.)
 - Two-Processor Switch (TPS) available
 - Operates in native mode (NCP) and/or emulation mode (EP)

TRANSMISSION SUB SYSTEM (TSS)

The TSS consists of Communication Scanner Processors (CSP), Front End Scanners (FES), line interfaces and Internal Clock Circuits (ICC)

- Communication Scanner Processor (CSP)
 - Microcoded processor which supports line protocols (S/S, BSC, SDLC) and provides character buffering.
 - CCU to CSP operation in:
 - 1) normal mode or
 - 2) 3705 type 2 scanner mode (all S/S and BSC neo-interface)
- Front End Scanner (FES)
 - One per CSP
 - Hardware only operation
 - Interfaces CSP and Line Interface Cards (LICs)
 - Provides line service management, serialization, deserialization
- Line Interface
 - Similar functions to those provided by 370x line sets.
 - 1 to 4 FDX/HDX lines depending on LIC type.

- Internal Clock Circuit (ICC)
 - Provides internal clock when it is not provided by Data Communication Equipment (DCE). It may also be used to clock the remote Data Terminal Equipment (DTE) when no DCE is used (direct attachment).

MAINTENANCE AND OPERATOR SUB SYSTEM (MOSS)

- Has the following main components: MOSS processor and storage (96Kbytes), diskette drive (51TD), control panel, operator console (separate keyboard/display unit).
- Is the primary interface for maintenance
- Main functions (provided by programs on diskettes)
 - 3725 initialization: MOSS IML, CCU initialization, CPS's IML.
 - CCU services: alter/display, address compare, branch trace, CCU control.
 - Scanner services: CSP alter/display, CSP connect /disconnect, CSP address compare.
 - MOSS/CSP dump
 - Box error record handling and recording.
 - Configuration Data File (CDF), Machine Load Table (MLT), Line Interface Block Display (LIBD), Graphic Configuration File (GCF).
 - Diskette swap.
 - MOSS/CSP dump transfer to host CPU
 - Concurrent testing (MOSS, wrap tests, OLTT's).

MODEL CONSIDERATIONS

The 3725 is available in two models. Differences are shown in the table below.

| Model 1 | Model 2 |
|-------------------------------------|-----------------------------|
| CCU STORAGE | |
| 512 or 768 or 1024 Kbytes | 512 Kbytes |
| Up to 256 lines | Up to 24 lines |
| Up to 14 Scanners | Only 1 Scanner |
| Up to 8 LICs per Scanner | Up to 6 LICs |
| Up to 6 C.A.s | Up to 2 C.A.s |
| Up to 8 channel connections | Up to 2 channel connections |
| TPS available | No TPS |
| Up to 2 frames 3725 mod. 1, 3726 | 1 frame only |

SOFTWARE SUPPORT

- ACF/NCP version 2 and beyond which is functionally equivalent to ACF/NCP V1 R3. Requires ACF/VTAM version 1 release 3 with appropriate PTF for MVS, version 2 release 1 for DOS VS and OS VS1.
- EP/V4 (EP4) and beyond.
- Advanced Communication Function/System Support Programs (ACF/SSP V2) will support both 3705 (ACF/NCP version 2 and EP/V3) and the 3725 (ACF/NCP version 2 and EP/V4).

MAINTENANCE STRATEGY

- Maintenance concept based on:
 - Customer problem determination based on in line notification (ALERT/ALARM)
 - Minimal host dependency
 - In line error detection, logging and analysis
 - On line wrap facilities
 - Off line resident fault locating diagnostics
 - Power on bring up tests
- The 3725 supports the communication network management direction by sending information to host resident Network Problem Determination Application (NPDA)

SUPPORT STRUCTURE

- Product category 2
- Two levels of training:
 - Product training
 - Product support training

CE CAREER PATH

This is a GS CE product

TECHNOLOGY

- Recent technologies are used (Dutchess, Golf, Purdue) as well as standard MST, VTL, FET.
- Extensive usage of ROS, RAM and microprocessors
- Power supplies
 - Ferro resonant transformers
 - Single phase control regulators
 - Series regulators

3725 OPERATOR CONSOLE

- Two operator consoles may be attached to the 3725.
- A primary operator console must be attached, the alternate operator console is optional.
- Both operator consoles are a 3727 model 70.
- Connected to the 3725 through an adapted CCITT V24/V28 interface.

IBM INTERNAL USE ONLY

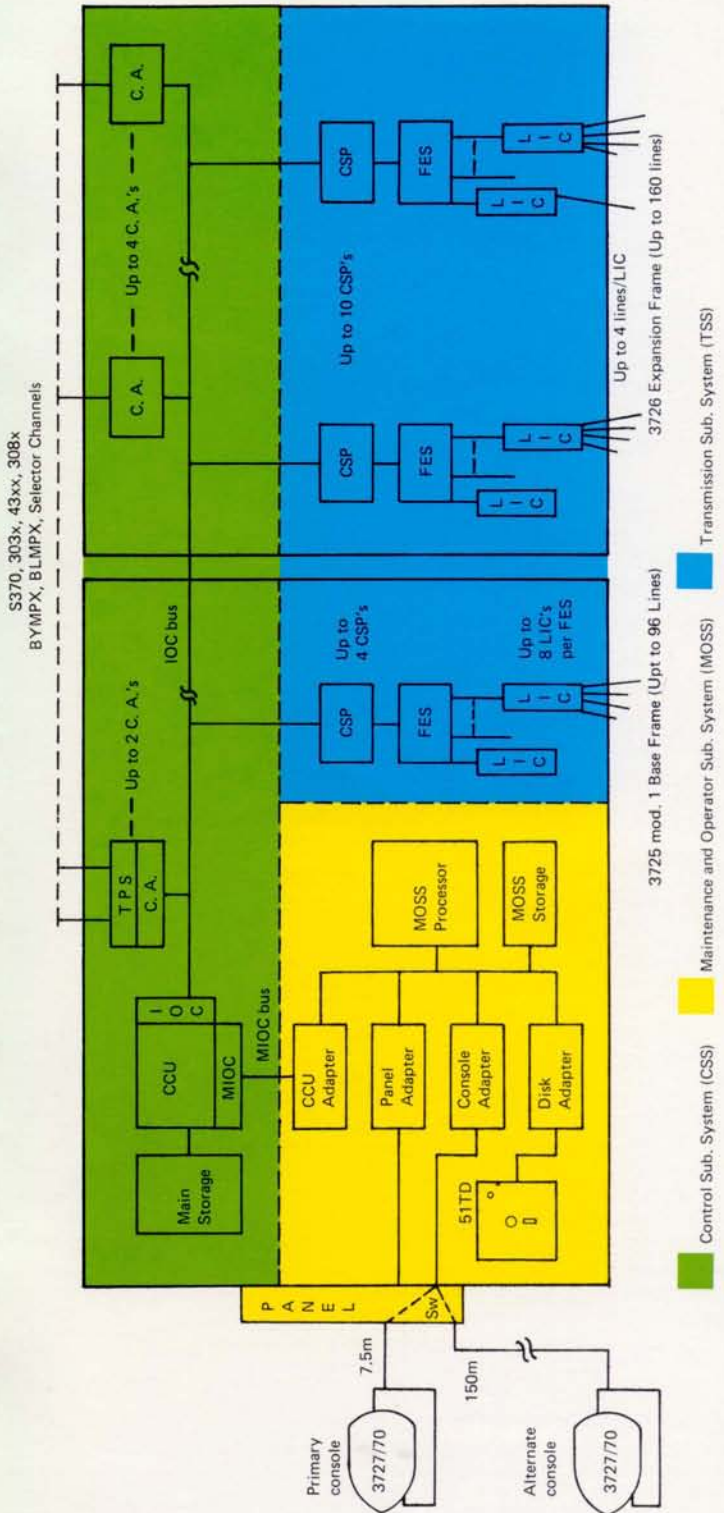

IBM INTERNAL USE ONLY

S370, 303x, 43xx, 308x
BYMPX, BLMPX, Selector Channels

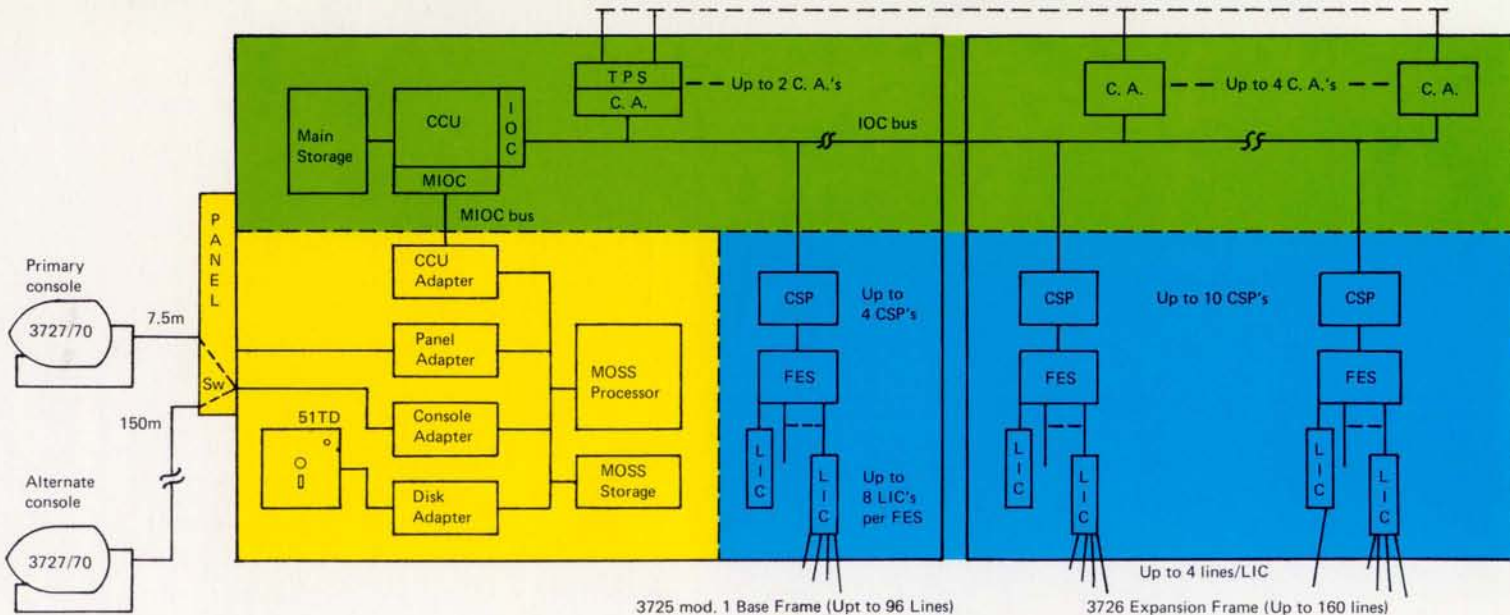

Control Sub. System (CSS)
 Maintenance and Operator Sub. System (MOSS)
 Transmission Sub. System (TSS)

3725 mod. 1 Base Frame (Upt to 96 Lines)

3726 Expansion Frame (Up to 160 lines)

IBM World Trade Corporation
Customer Engineering
Eurocoordination - Paris, France
A/FE - New York, USA

Printed in Western Germany

Dept. Form G 7902-740