

~~XXXXXXXXXXXXXXXXXXXX~~  
Use for 1622, which  
is the same in many  
respects (mechanically)

**IBM** Customer Engineering

Manual

~~XXXXXXXXXXXX~~

**1402** Card Read-Punch

INTRODUCTION .....	5
--------------------	---

### Functional Principles

OPERATING CONTROLS AND LIGHTS .....	6
FUNCTIONAL SWITCHES .....	7

### Preventive Maintenance

APPROACH TO PREVENTIVE MAINTENANCE .....	9
PREVENTIVE MAINTENANCE PROCEDURE .....	9

### Service Hints

INSTALLATION PROCEDURE .....	10
READ FEED .....	10
Reader Stop Lights .....	10
Reader Check Lights .....	10
Validity Lights .....	10
Picker Knife Timing Check .....	10
Brush Timing .....	10
Circuit Breaker Timings .....	10
PUNCH FEED .....	11
Punch Stop Lights .....	11
Punch Check Lights .....	11
Punch Check Brushes Out of Time .....	11
Punching Registration .....	11
Dropping Punches .....	11
Multiple Punches .....	11
Damaged Cards or Jams .....	11

### Principles of Operation and Adjustments Read Feed

DRIVE MECHANISM .....	12
Speed .....	12
READ CLUTCH .....	12
Principles of Operation .....	12
Adjustments .....	12
Timing .....	13
Clutch Pulley Assembly Removal .....	13
Clutch Drive Removal .....	13
Clutch Drive Installation .....	14
FILE FEED .....	15
Principles of Operation .....	15
Clutch Adjustments .....	16
Clutch Removal .....	16
Service Checks .....	16
Joggler Adjustments .....	16
HOPPER AND PICKER KNIVES .....	18
Principles of Operation .....	18
Adjustments .....	18
CARD GUIDES .....	19
Adjustments .....	19
CARD LEVERS .....	19
Adjustments .....	19
BRUSH UNITS .....	19
Service Checks .....	19
Adjustments .....	19
Brush Timing .....	20

# Contents

## Transport and Stackers

SELECTION MECHANISM .....	20
Principles of Operation .....	20
Chute Blade and Selector Magnet Adjustments .....	21
Transport Roll Adjustments .....	21
Jam Bar Adjustments .....	21
STACKERS .....	21
Principles of Operation .....	21
Stacker Adjustments .....	21
Stacker Jogger Adjustments .....	22

## Punch Feed

DRIVE MECHANISM .....	22
PUNCH FEED CLUTCH .....	24
Principles of Operation .....	24
Clutch Adjustments .....	24
Clutch Timing .....	26
Clutch Ratchet Removal .....	26
GENEVA .....	26
Principles of Operation .....	26
Adjustments .....	27
Timing .....	27
HOPPER AND PICKER KNIVES .....	27
Principles of Operation .....	27
Adjustments .....	27
CARD GUIDES .....	27
Adjustments .....	28
ALIGNER STATIONS AND INTERMITTENT FEED ROLLS .....	28
Principles of Operation .....	28
Timing Check at Punch Station .....	29
Forward and Side Aligner Adjustments .....	29
First Stepped Feed Roll Timing .....	30
First Intermittent Feed Roll Timing .....	30
Side Aligner Removal .....	30
Forward Aligner Removal .....	31
First Stepped Feed Roll Removal .....	31
Fourth and Fifth Upper Feed Roll Removal .....	31
Timing Check at Punch Check Brush Station .....	31
Second Stepped Feed Roll Timing .....	31
Second Intermittent Feed Roll Timing .....	32
Second Stepped Feed Roll Removal .....	32
ROLL OPENING DEVICE .....	33
Principles of Operation .....	33
BRUSH UNITS .....	33
PUNCH UNIT .....	33
Principles of Operation .....	33
Cam Follower Assembly Adjustments .....	35
Cam Follower Assembly Removal .....	35
Service Checks .....	35
Cam Follower Assembly Timing .....	35
Interposer Setup Bail Adjustments .....	35
Interposer Setup Bail Removal .....	35
Punch Magnet Yoke Assembly Adjustments .....	36
Service Checks .....	36
Punch Magnet Yoke Assembly Removal .....	36
Punch Magnet Unit Adjustments .....	36

Punch Magnet Unit Removal .....	36
Punch Magnet Unit Installation .....	37
Interposer Guide Comb Adjustments .....	37
Interposer and Interposer Link Removal .....	37
Stripper Assembly Removal .....	37
Stripper Assembly Installation .....	38
Latch Removal .....	38
Punch Removal .....	38
Punch Unit Vertical Position .....	38
Punching Registration .....	39
Punch Unit Timing .....	39
Punch Unit Removal .....	39
Punch Unit Installation .....	39
TIMING BELTS .....	40
Main Drive Belt Removal .....	40
Punch Unit Drive Belt Removal .....	40
First Stepped Feed Roll Drive Belt Removal .....	40
Belt Tension .....	40

## Electrical Contacts

PERMISSIVE MAKE RELAYS .....	40
Principles of Operation .....	40
Contact Replacement .....	40
CIRCUIT BREAKERS .....	41
Timing .....	42
OPEN STRAP CONTACTS .....	42
Adjustments .....	42
Timing .....	42

## Service Aids

C E SERVICE PANEL .....	42
-------------------------	----

## 1402 Circuits

POWER SUPPLY AND INTERLOCK CIRCUITS .....	43
Power On Sequence .....	43
Power Off Sequence .....	44
READ FEED CIRCUITS .....	44
Load Key Operation .....	44
Start Key Operation .....	44
Card Reading .....	44
Reader Non-Process Run-Out .....	44
Stop Key Operation .....	45
Card Jam Circuits .....	45
Clutch Check Circuit .....	45
PUNCH FEED CIRCUITS .....	45
Punch Feed Run-In .....	45
Punch Feed Read .....	46
Card Punching .....	46
Punch Check Brushes .....	46
Punch Non-Process Run-Out .....	46
Stop Key Operation .....	46
Card Jam Circuits .....	46
Clutch Check Circuit .....	46
Stacker Select Circuits .....	47
PM SCHEDULE .....	48

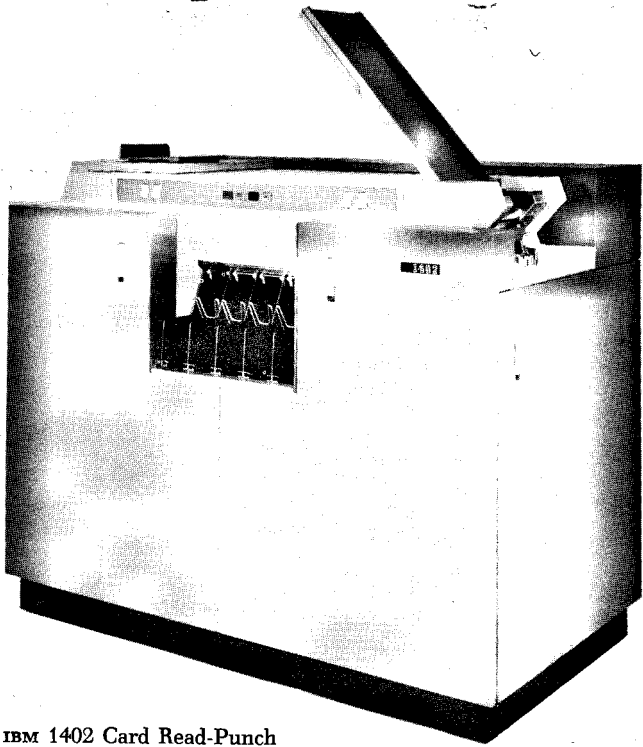

IBM 1402 Card Read-Punch

# IBM 1402 Card Read-Punch

## Introduction

The IBM 1402 Card Read-Punch provides the 1401 data processing system with a punched card input and output. The read feed is a 20 cycle-point feed equipped with a file feed which has a capacity of 3000 cards. The read feed can process cards at a speed of 800 cards per minute. The punch feed is a 16 cycle-point feed which can punch cards at 250 cards per minute. Five radial

stackers are used to accomplish stacking of the cards from both feeds. The read feed and the punch feed are located at opposite ends of the machine so that cards are fed in opposite directions into a transport assembly above the stackers. The card transport system is driven by timing belts wherever possible to reduce machine noise and maintenance. Power supplies for other machines of the system are located in the 1402.

## Functional Principles

The 1402 Card Read-Punch can read cards at a maximum speed of 800 cards per minute. Actual card speed is governed by the program routine. The read feed is equipped with a 3000 card capacity file feed. The cards are fed through the read feed, 9 edge first, face down. The card path is illustrated in the feed schematic diagram (Figure 1). As the card passes the read check brushes, 80 columns of the card are read to condition the hole count check planes in the 1401. It is then moved past the read brushes where again 80 columns of the card are read and entered into the read area of core storage. At the same time the check planes are conditioned so that a hole count check may be completed. Next, it is transported past the stacker selection station and is directed to the appropriate stacker under control of programming. Three stackers are available to receive cards from the read feed. The NR (Normal Read) stacker is used unless the cards are program-directed to stacker 1 or stacker 2 (8/2).

The 1402 Card Read-Punch will punch cards and check card punching at a maximum speed of 250 cards

per minute. Cards are placed in the 1200 card capacity hopper, 12 edge first, face down. Card feeding is illustrated in the feed schematic diagram (Figure 1). As the card passes the Punch Feed Read (Optional Feature), 80 columns of the card are read into the read areas of core storage of the 1401 if PFR is called for. Before the card is punched, it is aligned at the aligner station both vertically and horizontally to insure correct punching registration.

Punching is done by a high-speed punch unit. As the card passes the punch station, circuits are set up in the 1401 which allows the card to be punched with information contained in the punch area of core storage. At the same time the check plane cores are conditioned so that a hole count check may be performed. After the card is punched, it is read at the 80 column punch-check brushes to condition the check plane cores so that a hole count check may be completed. It is then moved past the stacker selection station and is directed to the appropriate stacker under program control. Three stackers are available to receive cards from the punch

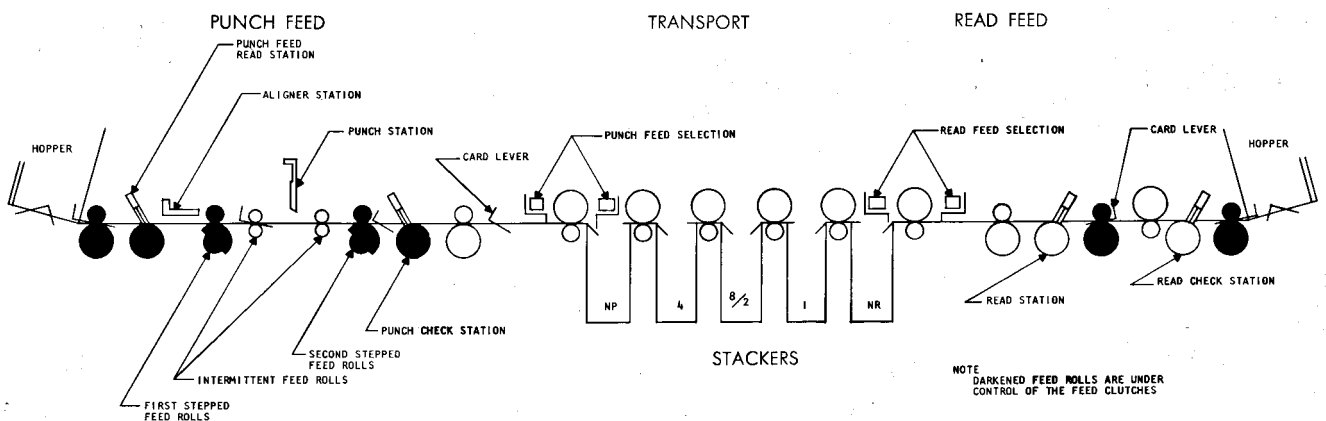

Figure 1. 1402 Feed Schematic

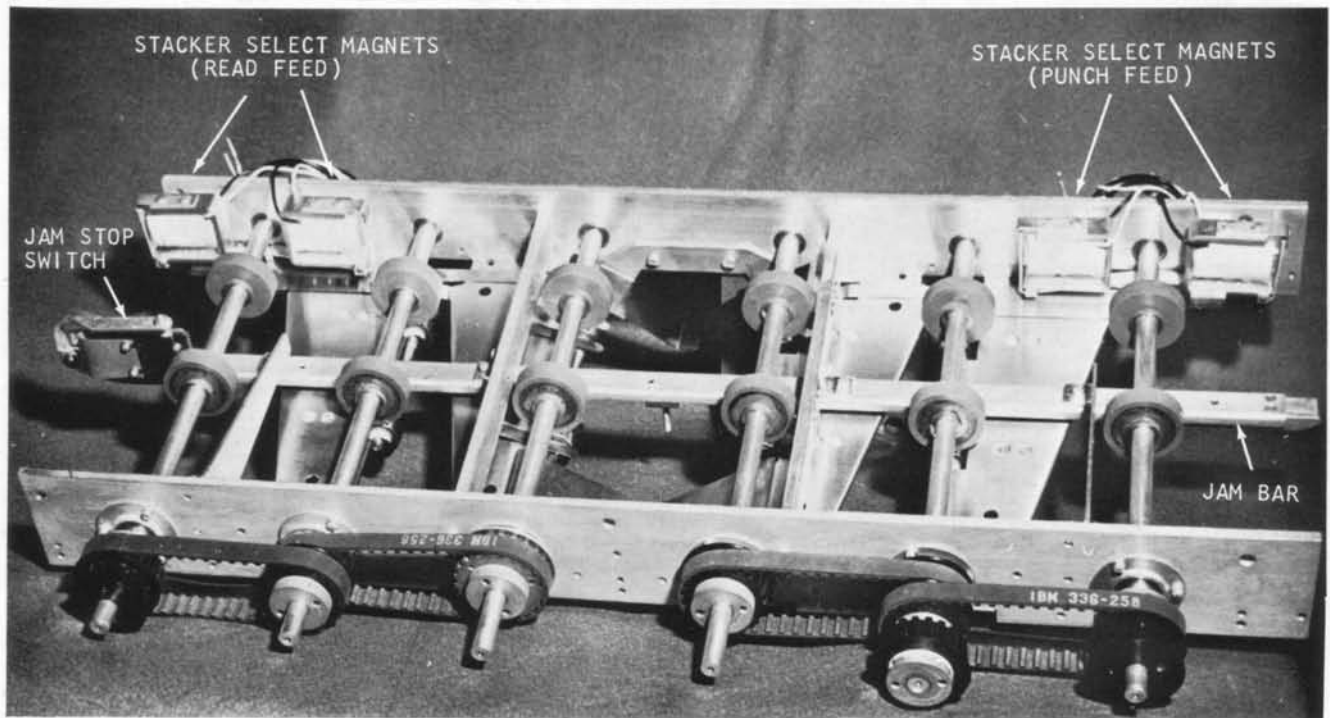

Figure 2. Transport Mechanism

feed. The NP (Normal Punch) stacker is used unless the cards are program-directed to stacker 4 or stacker 8 (8/2). The 8/2 stacker cannot be used for collating between the punch and read feeds.

The card transport assembly located between the punch feed and the read feed has a set of six feed rolls along with two select magnets and chute blades for the read feed as well as two select magnets and chute blades for the punch feed. A jam bar is located in the transport assembly to provide an indication and stop the machine when a card jam occurs (Figure 2).

All stackers are the non-stop unloading radial type stackers with a capacity of 1000 cards each. Cards can be removed from the stackers without stopping the machine. Two stackers are assigned exclusively to the read feed, and two are assigned exclusively to the punch feed. The center (8/2) stacker can be used by either unit, but it must be assigned by the program to one or the other, in any one run (Figure 3).

Both feeds are equipped with jam detection devices and with a misfeeding detection.

### Operating Controls and Lights (Figure 4)

**Read Switch:** Controls the read section of the machine. When this switch is OFF, the read feed is inoperative.

**Punch Switch:** Controls the punch section of the machine. When this switch is OFF, the punch feed is inoperative by program control. Cards can be run into the punch feed with the Punch Switch OFF by use of the Non-Process Runout punch switch.

**Start Switch:** Causes the read feed motor to start when the read switch is ON. One card will be fed into the punch feed if the Punch Switch is ON.

**Stop Switch:** Used to stop the system. If a program instruction is in process, it is completed before the stop occurs.

**Non-Process Runout-Read Switch:** Used to run cards out of the read feed. The last two cards run out will not be processed. The read hopper must be empty to make this switch effective.

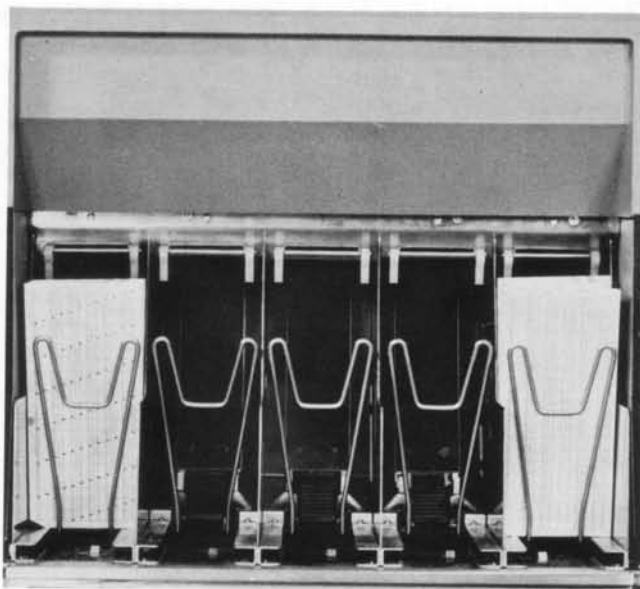

Figure 3. Radial Stackers

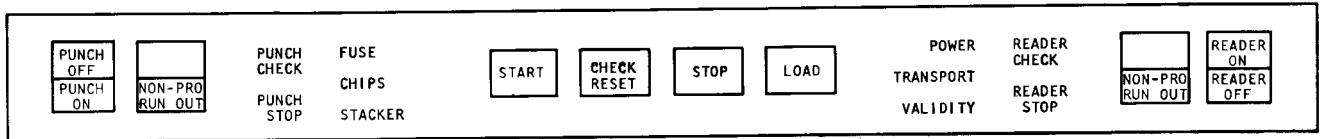

Figure 4. Operating Controls

**Non-Process Runout-Punch Switch:** Used to run cards out of the punch feed. The last two cards will not be punched. When the Punch Switch is ON, the hopper must be empty to make this switch effective.

**Load Switch:** Used to start loading instruction cards. Pressing the Load Key causes the read feed to operate until a card has passed the read brushes. After the card is read at the read brushes, the program can start and execute the instruction that is punched in the card. Continued operation is under control of programming. When the Punch Switch is ON, pressing the Load Key causes the punch to run in one card.

**Check Reset Switch:** Must be pressed to reset an error indication before the Start Key can become operative. This switch is operative only when the feed in error is empty of all cards.

**Power-On Light:** When power is supplied to the read-punch unit, this light is on.

**Reader Stop Light:** A feed failure or a card jam in the read-feed causes the machine to stop and the Reader-Stop light to come on.

**Punch Stop Light:** A feed failure or a card jam in the punch feed causes the machine to stop and the Punch-Stop light to come on.

**Validity Light:** This light comes on if an invalid character is detected during a read operation.

**Read Check Light:** This light comes on under control of the data processing system when an error is detected during card reading.

**Punch Check Light:** This light comes on under control of the data processing system when an error is detected during the punching of a card.

**Stacker Light:** If any of the five stackers become full, the machine stops and this light comes on.

**Fuse Light:** This light signals a blown signal fuse in the card read-punch.

**Chips Light:** This light comes on when the chip box becomes full, or is not in place. Either condition will stop the machine. The light may come on for a short period before the machine stops.

**Transport Light:** This light is turned on by the jam

contact. It indicates that a card has jammed in the transport feed roll area.

**END-OF-FILE OPERATION:** When the reader hopper becomes empty, the Start Key must be pressed to cause the last two cards to be processed.

## Functional Switches

**Cover Interlocks:** When the respective cover is opened, the respective interlock switch will open the circuit to the punch and reader, motor and run circuits.

**Punch Magazine Interlock:** When the magazine locking lever is opened, this switch opens the circuit to the punch motor and motor starts relays.

**Die Lift Interlock:** This switch provides the same function as the magazine interlock when the lowering frame is lowered.

**Crank Interlock:** This is a manually operated switch which must be turned off to insert the hand crank. It provides the same function as the magazine interlock while using the hand crank.

**Die Interlock:** This switch provides the same function as the magazine interlock when the die is removed or improperly located.

**Stacker Switch:** This switch operates when any of the 5 stackers are filled. When transferred, it opens the circuit to the punch and reader, start and run circuits. It also closes the circuit to the stacker indicating light when transferred.

**Jam Bar Switch:** When a jam occurs, this switch provides the same function as the stacker switch except that it completes a circuit to the transport light when transferred.

**Joggle Switch:** This switch is operated when the hinged front joggler assembly is opened. It opens the circuit to the reader motor control relay.

**Chips 1 and 2 Switches:** These switches operate when the chip box is full or removed from the machine. Operation of either switch will open the punch motor and run circuits as well as light up the "chips" indicating lamp.

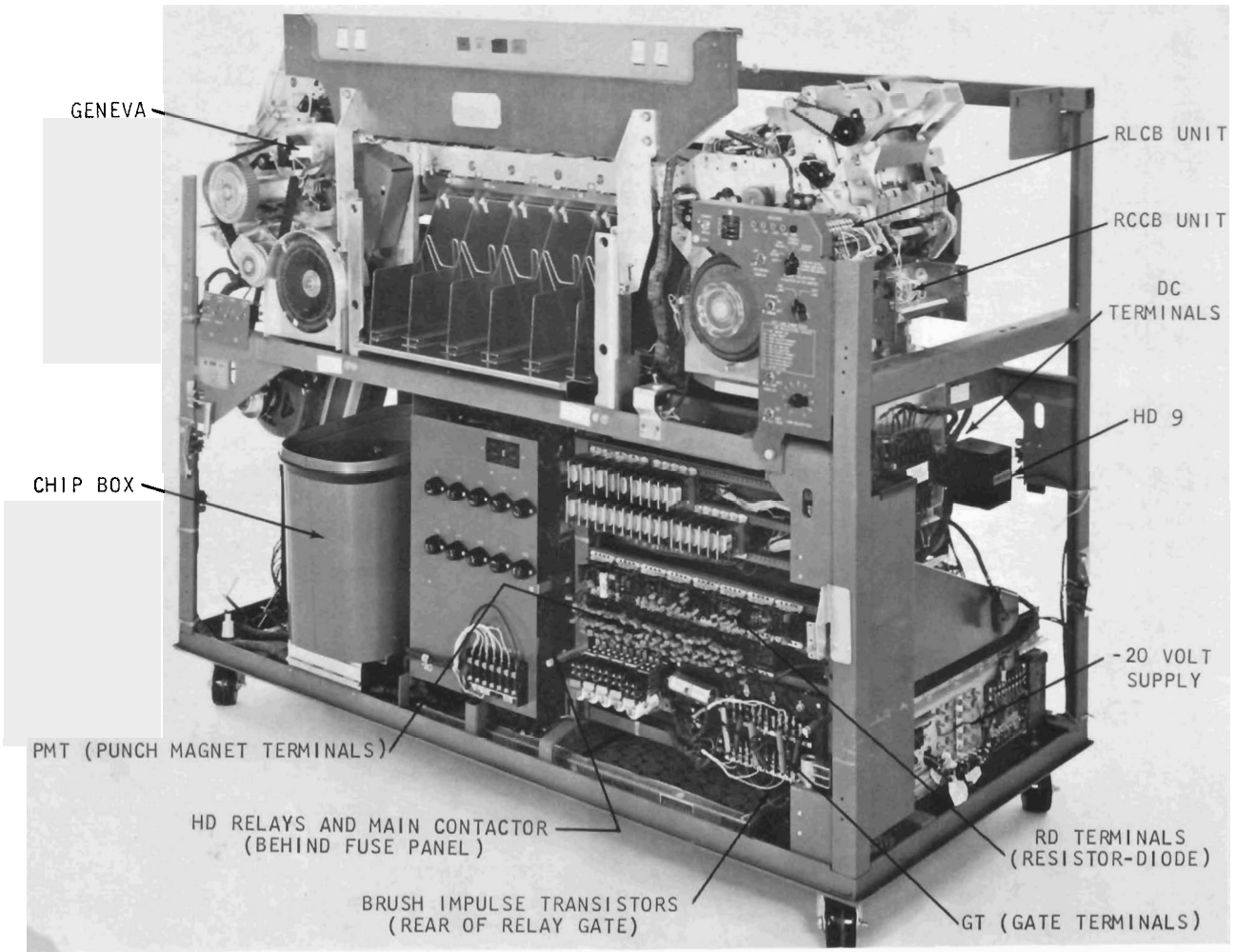

Figure 5. 1402 Front View



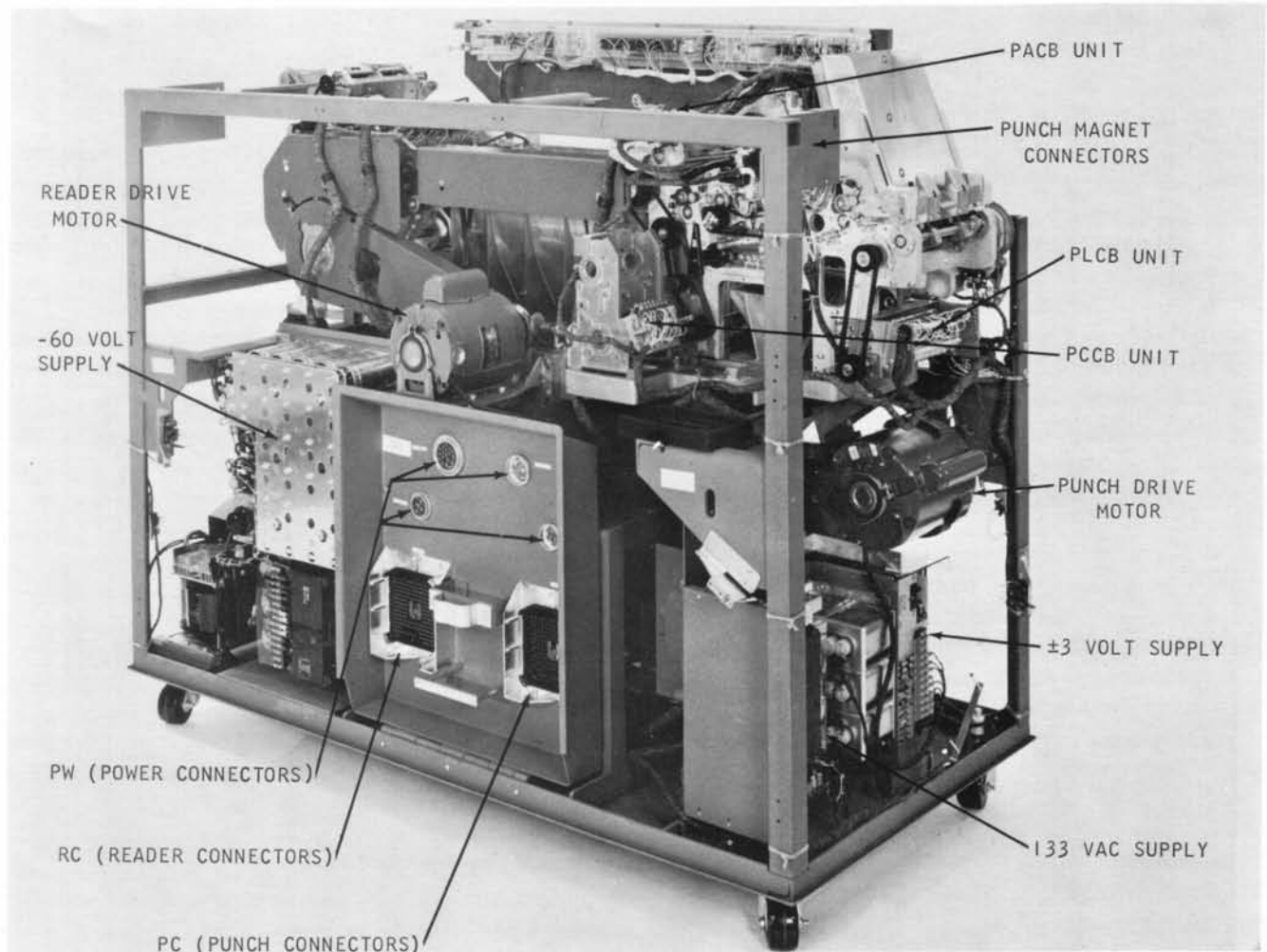

Figure 6. 1402 Rear View

## Preventive Maintenance

### Approach to Preventive Maintenance

1. The prime objective of any maintenance activity is to provide maximum machine availability to the customer. Unless a preventive maintenance operation reduces machine downtime, it is unnecessary.

2. Be visually alert for trouble indications any time you service the machine. Look for corrosion, wear, cracks, burnt contacts and loose connections. Watch for filters clogged with dirt.

### Preventive Maintenance Procedure

1. The three basic steps of preventive maintenance are clean, lubricate, and inspect. Do not do more than scheduled preventive maintenance on equipment which is operating satisfactorily.

2. Apply lubrication only in the quantity necessary to supply that immediate area involved. Wipe off excess.

## Service Hints

### Installation Procedure

1. Remove shipping braces, tape, and blocks under feed shock mounts.
2. Install the upper magazine of the file feed.
  - a. Remove front and rear covers over the sides of hopper casting.
  - b. Just above the file feed drive shaft is a split shaft held by a set screw; slip both halves of the shaft to the center so they are inside the casting.
  - c. Put upper magazine in position and slip both halves of the split shaft from the center so they will hold the magazine in place. The ends of the split shaft should be flush with the end of the magazine holes.
  - d. Turn split shafts so the setscrew bites both halves and tighten the setscrew.
  - e. Replace the two covers.
  - f. Check operation of file feed. Adjust hopper delay potentiometer so approximately 1½" to 2" of cards enter the hopper before feeding begins.
3. Examine all relays (without removing) for displaced armatures.
4. Trip the clutches and turn machine by hand, checking for any binding conditions in the feeds or card transport.
5. After installing main line cord through the bottom of the machine, check that the cable clamp is fastened securely to bottom plate of machine.
6. Check the power supply voltages at the CE service panel.
7. Check covers for proper fit and appearance.
8. Tighten the screws in all CB contact stacks.
9. Run test decks to verify correct machine operation.

### Read Feed

#### Reader Stop Lights

1. Frequent misfeeding of cards caused by insufficient weight of cards over the picker knives indicating the file feed requires re-adjustment. The time delay should be at least three seconds before the clutch operates and at least ½ inch of cards should be in the hopper while feeding.
2. False reader stops may be caused by number 1 or number 2 card levers bouncing. Set cam display switch to position 5 and then position 6 while observing the timer index. A bouncing card lever will show up as a spot of light between 158° and 188°. Re-adjust card lever contacts.

#### Reader Check Lights

1. This may occur as a result of the card skewing between read stations. Inspect the transport area particularly for uneven feed roll pressure. Pressure should measure at least 1½ pounds on a strip of IBM card when drawn through any single set of feed rolls.
2. Failing to read a certain column of the card. This is quite often an open somewhere between the brush and the row bit core in storage. To check, raise the brush assembly from the contact roll and measure the voltage between the brush in question and ground. A normal brush should read —20 v (an open line will be zero).
3. Brushes raised off contact roll.
4. Loose or broken common brush.
5. Bad IBM 022 transistor.

#### Validity Lights

1. Intermittent make of read two common brush.
2. Cards feeding late so that brush span time spans the make of two impulse CB's.
3. Cards feeding skewed so that one brush reads two columns. This is usually confined to one end of the card depending on which way the skew occurs.

#### Picker Knife Timing Check

Feed a card until the trailing edge is aligned with the throat knife. The timer should read 75° ±1°.

#### Brush Timing

Checking brush timing or any 1402 timings may require removal of the 200 position connector to eliminate back circuits.

#### Circuit Breaker Timings

Excessive timing variations in clutched CB's or brush impulses can be caused by one of the following:

1. Loose motor drive belt.
2. Loose clutched feed roll belt.
3. Loose screws in the clutch pulley assembly.
4. Excessive flexibility of the clutch pulley shock mount because of defective bonding.
5. Excessive backlash in clutch (engaged) because of wear. Try a new sized detent (P/N 609737 to 609743). NOTE: Check the 1401 *Service Hints* for other possibilities.

#### Punch Feed

##### Punch Stop Lights

Causes are normally the same as those listed under reader stop lights.

### **Punch Check Lights**

Causes are normally the same as those listed under reader check lights.

### **Punch Check Brushes Out of Time**

1. If all digits are out of time, check the tension of the second stepped feed roll.
2. If the lower digits (5-9) are out of time, check the tension of the sixth feed roll.

### **Punching Registration**

1. Cards being punched off by one digit can be caused by a loose main drive belt. This usually happens when the clutch latches, causing the belt to jump one tooth on the first stepped feed roll drive pulley.
2. Variable registration (12 through 9) may be caused by intermittent rolls becoming polished. This is caused by running the machine excessively without cards. The intermittent rolls are vapor blasted and running together shortens the life of the vapor blast.
3. Variable registration (12 through 9) may be caused by insufficient roll tension. Tension trouble can be caused by cam follower bottoming or a weak spring.
4. If registration is off all the way across the card, check the mesh of the geneva gears, or for a loose pin.
5. If vertical registration varies slightly, check the pressure shoe springs for tension, or that they have not become polished at a point where they contact the card.
6. Varying vertical registration can be caused by intermittent roll closing too soon and moving card slightly at the end of the previous geneva cycle.

7. If horizontal registration is varying, check the side aligner adjustment.

### **Dropping Punches**

1. Check the interposer to punch clearance. It should not exceed .015".
2. Check the clearance between the lower side of the punch magnet armature and its latch for at least .007".
3. Check the punch magnet armature pivot rod clearance.
4. Check for bent or loose punch magnet armature leaf springs.
5. The miniature punch magnet connector terminals can become dislocated and make a poor connection.

### **Multiple Punches**

1. Check the clearance between the lower side of the punch magnet armature and the latch for not more than .013".
2. Broken latch springs or latch spring hooks.

### **Damaged Cards or Jams**

1. Intermittent errors and card jamming may be caused by loose or damaged timing belts.
2. If cards are being nicked on the leading edge by the punches, check the timing of the first stepped feed roll.
3. If the punch unit cuts long holes or is tearing holes, check the punch unit timing.

# Principles of Operation and Adjustments

## Read Feed

### Drive Mechanism (Figure 1)

A ¼h.p. motor drives the input pulley on the read feed. The following are kept continuously running:

1. Timer index
2. Clutch ratchet
3. Two contact rolls
4. First feed roll after each contact roll
5. Continuously running CB's (RC)
6. File feed drive shaft
7. Three transport feed rolls
8. Stacker jogglers for NR, 1 and 8/2 pockets

When the read clutch engages, power is transmitted to the following:

1. Picker knife cam shaft
2. Feed knives
3. First feed roll before each contact roll
4. Clutch controlled CB's (RL)

### Speed

Adjust the motor pulley to feed cards  $800 \pm 3$  cards per minute.

## Read Clutch

### Principles of Operation (Figures 7 and 8)

The clutch ratchet is continuously running and makes one-half revolution each machine cycle. This ratchet is engaged by a drive dog and detent, which are controlled by the action of the drive arm and intermediate arm.

The dog and detent are spring-loaded to engage the ratchet (Figure 7). They pivot on studs that are part of the drive arm and are controlled by studs that are part of the intermediate arm. The intermediate arm pivots on a sleeve that is the hub of the drive arm.

To see the engaging action of the clutch, assume the clutch is latched as shown in Figure 8.

Impulsing the magnet releases the latch and allows the intermediate arm to move in relation to the drive arm. The intermediate arm moves counterclockwise due to the spring-loaded dog and detent exerting force on the control studs. As the intermediate arm moves, the dog and detent are allowed to engage the ratchet and rotate the mechanism that drives the feed knives and controlled feed rolls.

Unless the clutch magnet is again impulsed, the clutch will disengage when the opposite end of the arm

strikes the latch. The intermediate arm, having moved clockwise in relation to the drive arm, will strike the latch first. The drive arm continues to move, and in so doing, causes the dog and detent to be cammed away from the ratchet by the motion of the pivot studs with reference to the control studs on the intermediate arm. Inertia carries the drive arm forward to strike the latch, and the keeper falls behind it to hold the clutch latched at  $315^\circ$ .

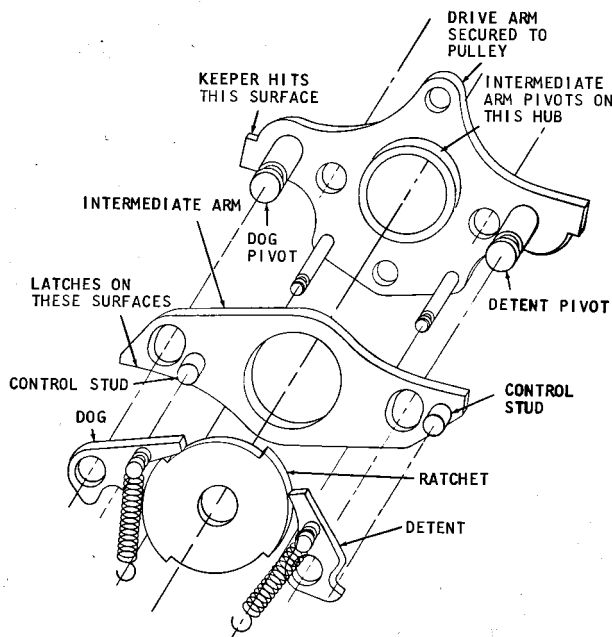

Figure 7. Clutch Operation

### Clutch Adjustments

The read clutch may be adjusted either in the machine or with the clutch drive unit removed from the base. The following sequence is used to adjust the clutch:

1. Adjust the armature pivot bracket to maintain a .001" to .003" clearance between armature and core (Figure 8).
2. Adjust the clearance between armature and upper yoke for .020" to .022" with latch against backstop.
3. Position complete clutch assembly to meet two conditions simultaneously:
  - a. The drive arm should clear the keeper at a position adjacent to the keeper pivot stud by  $\frac{1}{32}$ ".
  - b. With the armature fully attracted, there should be unlatching clearance of .008" to .012" (Figure 9).

4. Obtaining these adjustments should result in the drive arm and intermediate arm meeting the latch squarely.

5. Set both positioning blocks against the assembly to facilitate later adjustments.

6. Check for a maximum of .002" clearance between the step on the ratchet, and the detent (backlash) with clutch engaged. Check both steps of the ratchet and adjust to tightest side. If more than .002", replace with a longer detent.

NOTE: Seven new detents (P/N 609737 to 609743) are available. These detents are etched 1 through 7. Detent #1 is .002" longer than the original and #2 is .002" longer than #1, etc.

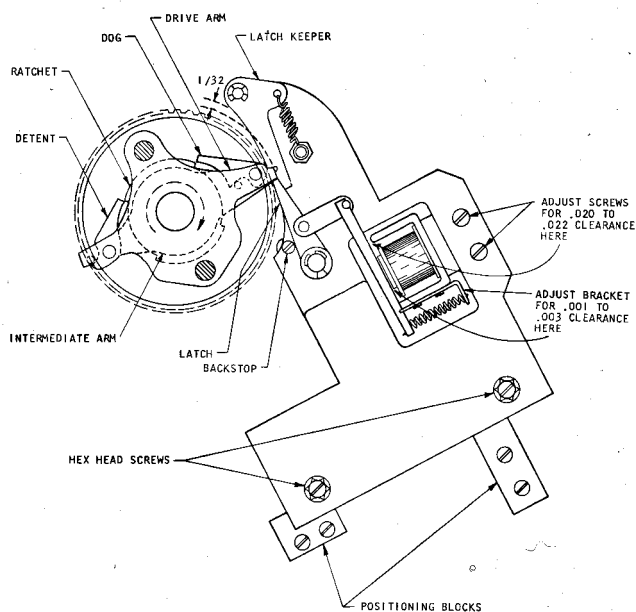

Figure 8. Magnet Assembly Adjustment

### Clutch Timing

This adjustment insures that the read feed dynamic timer is in time with the clutch at engaging time.

1. Block the clutch armature attracted.
2. While holding the keeper down, crank the machine and listen or feel for the keeper to fall behind the drive arm. This should happen at  $315^\circ \pm 1^\circ$  (Figure 8).
3. If the index is not at  $315^\circ \pm 1^\circ$  when the keeper falls behind the drive arm, loosen the clamped hub on the index drive shaft and turn the index to  $315^\circ$ .
4. Tighten the clamped hub.

### Clutch Pulley Assembly Removal (Figure 10)

The clutch pulley includes the dogs and arms that operate them. Remove the pulley as follows:

1. Spot mark the clutch pulley and the picker knife cam shaft pulley to the belt (This is to retain RLCB's and picker knife timing).

2. Remove the file feed drive belt.
3. Loosen the idler for the clutch pulley belt.
4. Remove the grease fitting on the end of the clutch shaft.
5. Loosen retaining clamp and remove the clamp and file feed drive pulley together.
6. Remove the clutch pulley drive belt.
7. Remove the clutch pulley assembly. It may be necessary to loosen the V-belt input pulley and move it towards the end of its shaft.

Install the clutch pulley assembly as follows:

1. Be certain that two thrust bearings (washers) are on the shaft against the clutch ratchet.

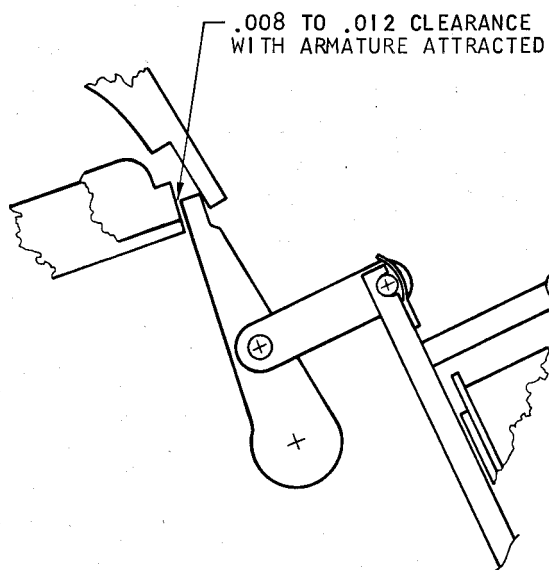

Figure 9. Clutch Unlatching Clearance

2. Install the clutch pulley, operating the arms so that the detent and dog fit into the high dwell of the ratchet.
3. Place the two thrust bearings against the clutch pulley.
4. Install the clutch retaining clamp (and file feed pulley), allowing no end play of the pulley.
5. Install the clutch pulley belt with spot marks lined up and adjust the idler.
6. Install the grease fitting and the file feed drive belt.
7. Reposition V-belt input pulley, if it was moved.
8. Check picker knife timing and RLCB's timing.

### Clutch Drive Removal (Figure 10)

1. Locate the positioning blocks firmly against the drive assembly and tighten.

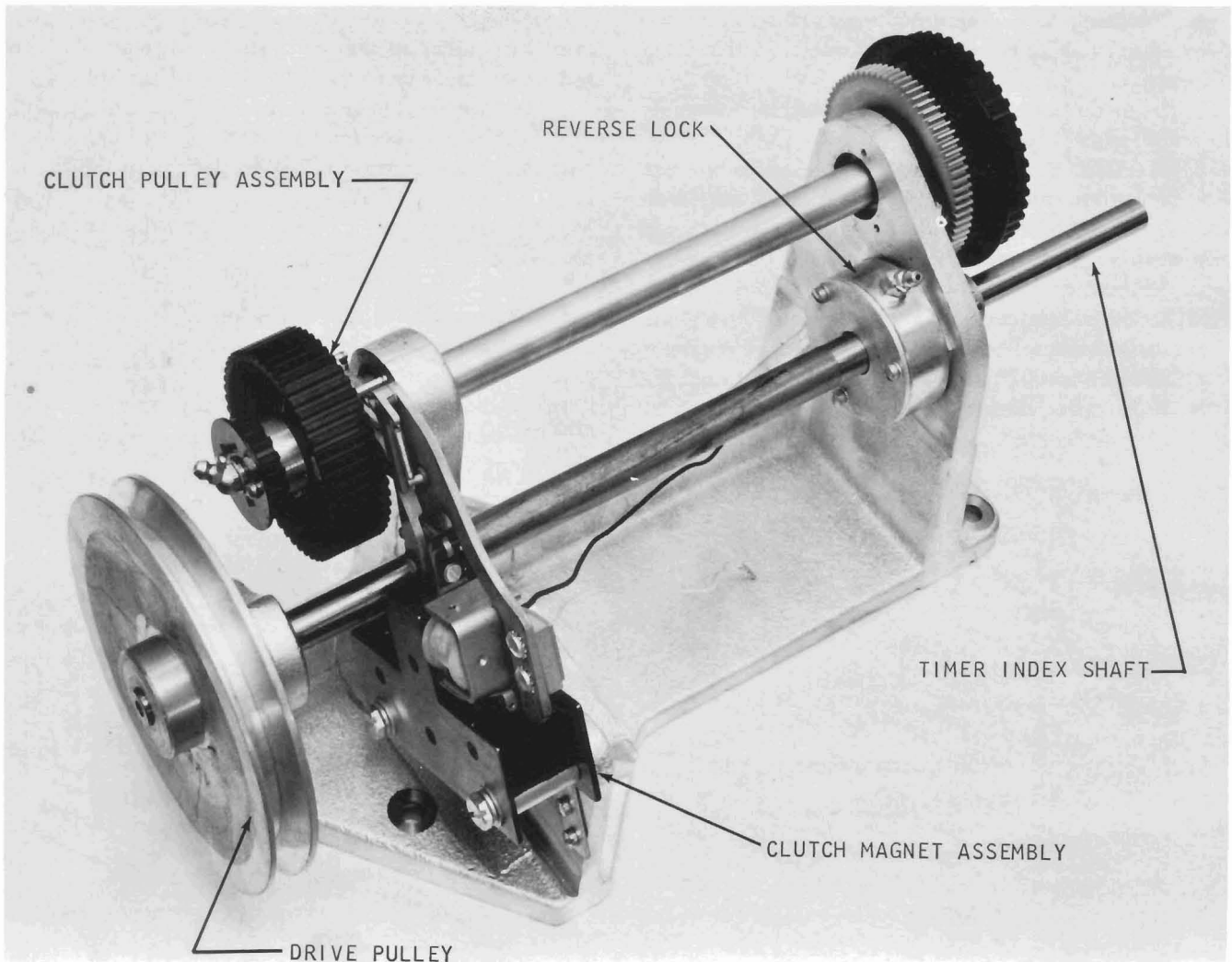

Figure 10. Clutch Drive Assembly

NOTE: This is set at the factory and should not be changed unless belt tightness needs to be adjusted or idler gear wink changed.

2. Scribe a line along one end of the unit to maintain front to rear location.
3. Establish RCCB timing as follows:
  - a. Block clutch armature and turn machine until keeper falls behind the drive arm ( $315^\circ$ ).
  - b. Spot mark RCCB drive gear to CB side casting or to gear guard.
4. Remove dynamic timer index as follows:
  - a. Remove screw from hand crank.
  - b. Remove two screws from index base.
  - c. Loosen clamped hub on index shaft.
  - d. Unplug index cable.
5. Remove four drive belts.
  - a. Contact roll drive (front)
  - b. File feed drive (rear)
  - c. Motor drive (rear)
  - d. Clutched feed roll drive (rear). Loosen the

- belt take up pulley bracket.
6. Remove the clutch magnet leads at the terminal block.
7. Remove the four hex-head clutch-drive assembly mounting screws.
8. Remove the assembly to the rear.

#### Clutch Drive Installation

1. Set the drive assembly in position from the rear.
2. Block the clutch armature attracted.
3. With the keeper behind the drive arm ( $315^\circ$ ), mesh the RCCB drive gear to the idler while keeping the spot marks aligned.
4. Install four drive assembly mounting screws; do not tighten.
5. Position clutch drive assembly against locating blocks and on scribed line on end of unit. Tighten mounting screws.
6. Install dynamic timer index (leave clamped hub loose).

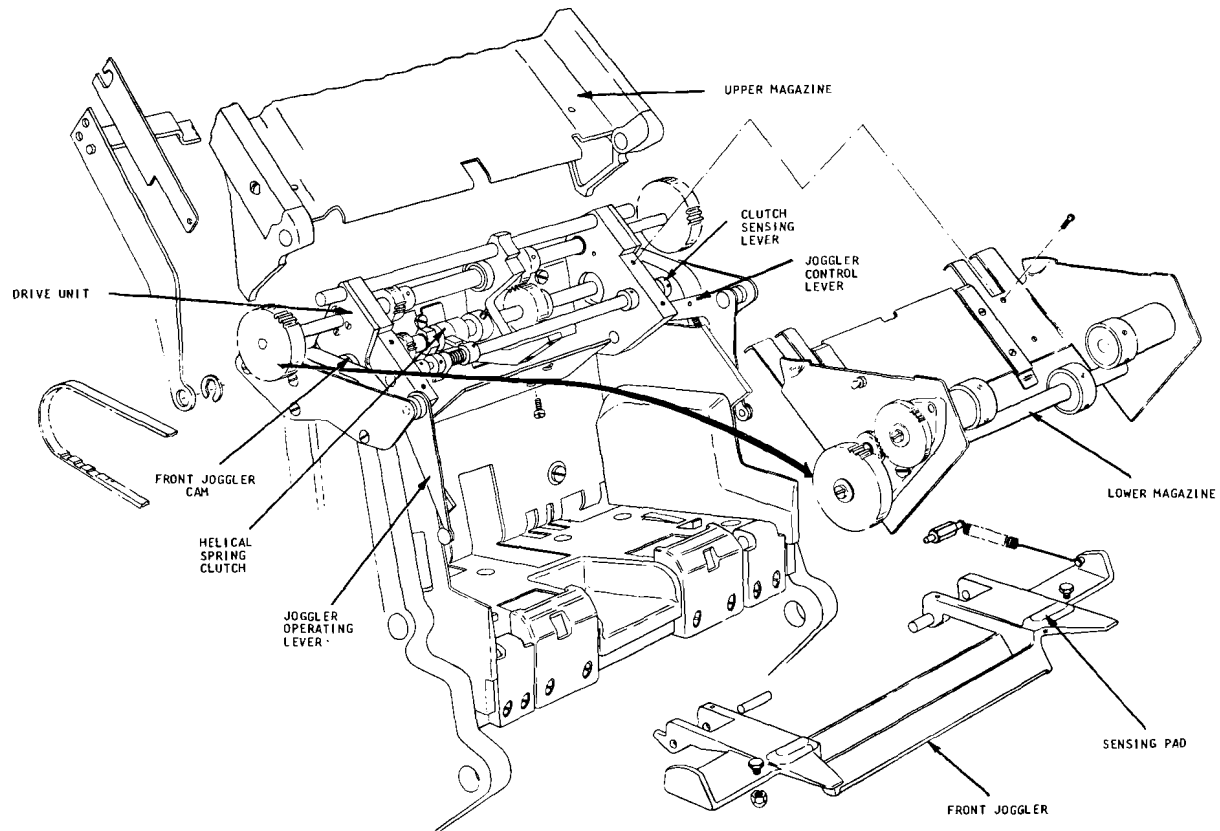

Figure 11. File Feed

7. With the magnet armature attracted and the keeper behind the drive arm, set the index to  $315^\circ \pm 1^\circ$  and tighten clamped hub.
8. Feed a card in by turning the picker knife cam shaft until card is against first set of feed rolls.
9. Turn machine to  $221^\circ$  and install clutch drive belt and adjust the idler pulley.
10. Install the other three belts and unblock the clutch armature.
11. Check the following timings:
  - a. Clutch engagement time ( $315^\circ \pm 1^\circ$ )
  - b. Brush impulse CB timing (Use CE aid panel)
  - c. Timing of the RCCB's.

## File Feed

### Principles of Operation (Figure 11)

The file feed consist of two basic units:

1. Upper magazine
2. Lower magazine

The upper magazine is the tray which holds up to 3,000 cards to be fed into the hopper. This tray is

hinged and can be locked at an angle to make the brush area of the machine more accessible.

The lower magazine contains clutch controlled feed rolls that feed the cards into the hopper. Operation of the helical spring-type feed roll clutch is controlled by the level of the cards in the hopper. Under spring tension, the front jogger applies pressure on the jogger operating lever, causing the lever to follow the contour of the front jogger cam. As the front jogger cam rotates, the front jogger oscillates, joggling the cards into position. If there are sufficient cards in the hopper to cover the sensing pads, the inward travel of the jogger is limited and the jogger control lever is not allowed to follow the low dwell of the front jogger cam. There will be no clutch action or cards fed down into the hopper at this time.

When the card level drops below the sensing pads, the additional travel of the jogger forces the jogger operating lever to follow the low dwell of the front jogger cam. At this time, the tab on the jogger operating lever will cause the clutch operating lever to rotate counterclockwise, pivoting the clutch latch out of the step in the clutch sleeve. The helical spring grips

the shaft, and the feed rolls are driven. Cards feed until card level in the hopper again reaches the sensing pads and then the clutch latches.

Cards are automatically front- and side-joggled in the hopper. Correct operating jogglers produce a deck with almost perfectly straight sides. The front joggler can be opened for insertion or removal of either cards or card weight.

The card weight is designed to pass through the lower magazine into the hopper and must be used to feed the last cards.

The front joggler interlock, mounted under the read hopper, renders the machine inoperative unless the front joggler is closed.

### Clutch Adjustments

With the clutch latch against the latch step on the sleeve, loosen the split collar and rotate the collar backwards (opposite normal direction) until stopped by the spring fully uncoiled inside the sleeve. While holding the split collar in this position, rotate the detent gear to  $\frac{1}{16}$ " past detent position. This should result in  $\frac{1}{16}$ " overthrow (Figure 12).

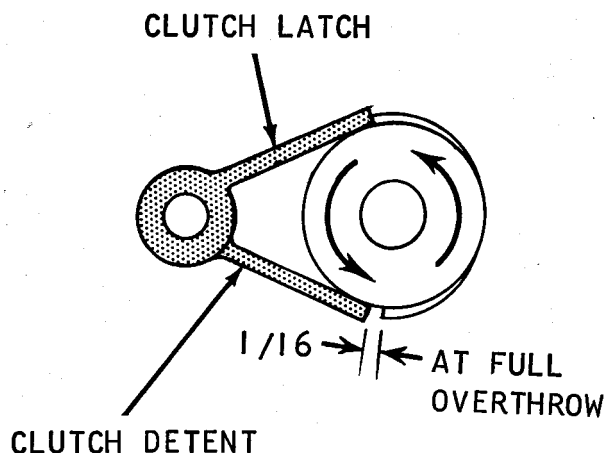

Figure 12. File Feed Clutch Adjustment

### Clutch Removal

1. Remove the covers and the upper and lower magazines.
2. Remove the drive unit from the machine.
3. Remove the rear pulley and the front and rear joggler cams. NOTE: Mark the cams and shaft to maintain relationship.
4. Remove the rear bearing retainer plate.
5. Loosen the side joggler cam, clutch hub (with grease fitting), and the clutch drive gear on the joggler cam shaft. These set screws are seated in undercuts on the shaft and must be loosened a full turn. Slide the shaft out of the rear of the unit.

6. Remove the clutch assembly through the bottom of the unit. The clutch can now be dis-assembled and the spring removed.

7. Re-assemble in the reverse order. Be careful to have the clutch latch and the detent in their correct positions, and the grease fittings over the slot in the shaft. The clutch drive sleeve and the side joggler cam should hold the clutch together, with the clutch in full mesh. The sleeve and the side joggler cam should not squeeze the clutch so tightly as to cause binding when the clutch is latched. Check all drive unit adjustments after the unit is replaced in the machine.

### Service Checks

1. The front joggler interlocking arm should have approximately  $\frac{1}{16}$ " travel before contact makes.
2. The upper card deck support must be centered between the side frames.
3. The front joggler operating levers must be free of binds between the side plates and the lower magazine.
4. Hopper bed plate springs must be  $\frac{3}{8}$ "  $\pm$   $\frac{1}{16}$ " above hopper bed plate.
5. Shims are available to shim the lower magazine if the speed nuts interfere with the helical spring clutch.

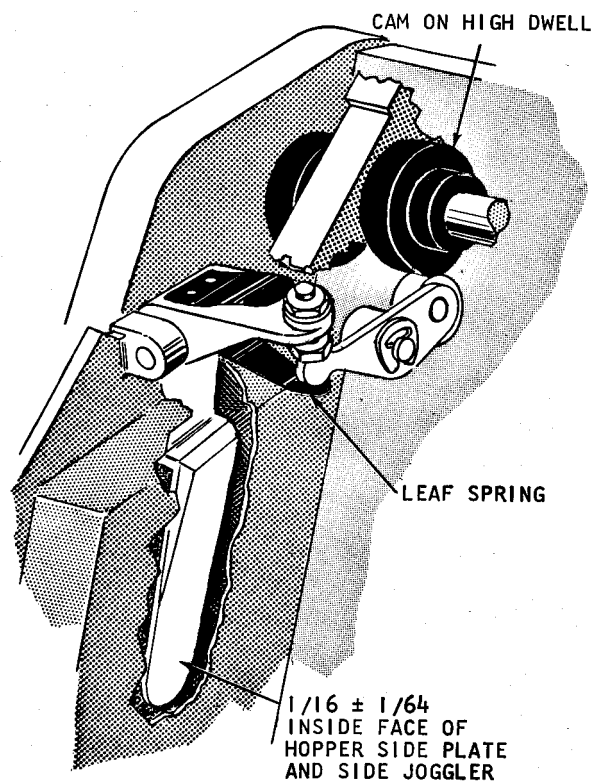

Figure 14. Side Joggler

### Joggler Adjustments

1. Turn the file feed drive unit until the front joggler cam followers are on the low dwells of the cams. Fill



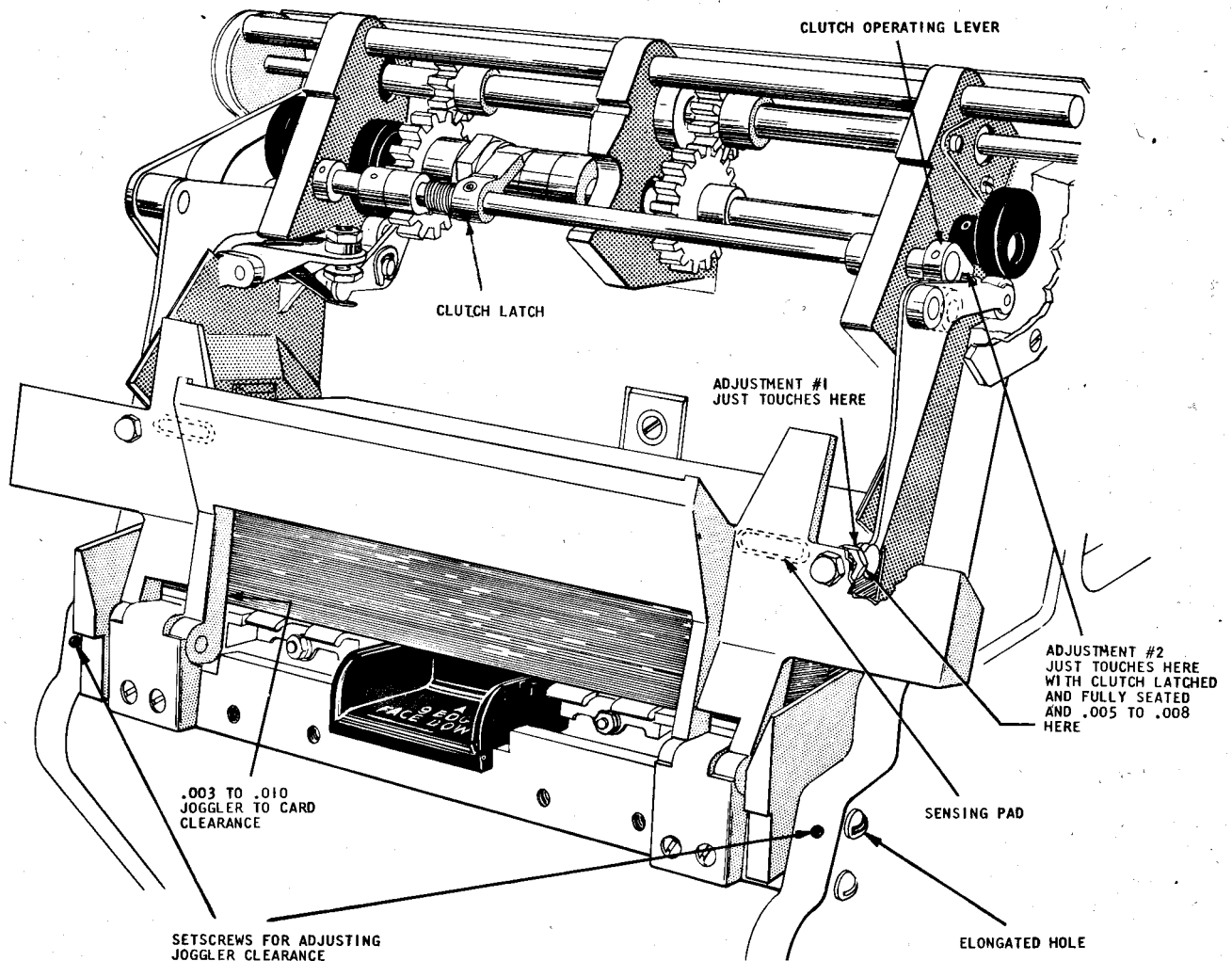

Figure 13. File Feed Adjustments

the hopper to just below the sensing pads on the front joggler and close joggler. Set the adjusting screws on the joggler to just touch the operating arms (Figure 13). Under these conditions there should be .003"-.010" clearance between the cards and the lower end of the joggling surfaces (the lower end of the joggling surfaces is in line with the top of the card feed knife posts). This clearance is obtained by adjusting the hopper post mounting bar with the set screws (Figure 13). The hopper posts will now have to be adjusted (Refer to *Hopper Adjustments*).

2. Turn the file feed drive until the front joggler cam followers are on the high dwell of the cams. Fill the hopper with cards to a level even with the top of the sensing pads and close the joggler. Hold the rear cam follower against the cam, and continue to operate the unit. Stop when .005"-.008" clearance appears between the cam follower arm and the adjusting screws.

Loosen the clutch operating lever on its pivot shaft and fully seat the clutch latch. With the cam follower against the cam, position the clutch operating lever so that it just touches the turned over ear on the cam follower arm (Figure 13). Tighten the set screws in the clutch operating lever, securing it to its shaft.

3. Turn the file feed drive until the hopper joggler cam follower is on the high dwell of the cam. Set the adjustment screw for  $\frac{1}{16}'' \pm \frac{1}{64}''$  travel of the side joggler past the inside face of the hopper side plate (Figure 14).

4. Adjust the lower magazine throat so that they are .020" to .040" above the imaginary plane determined by the tops of the feed rolls (Figure 15). NOTE: There is no timing relationship between the side and front joggler cams, nor between the cams and the feed knives. However, the front joggler cams should be even with each other.

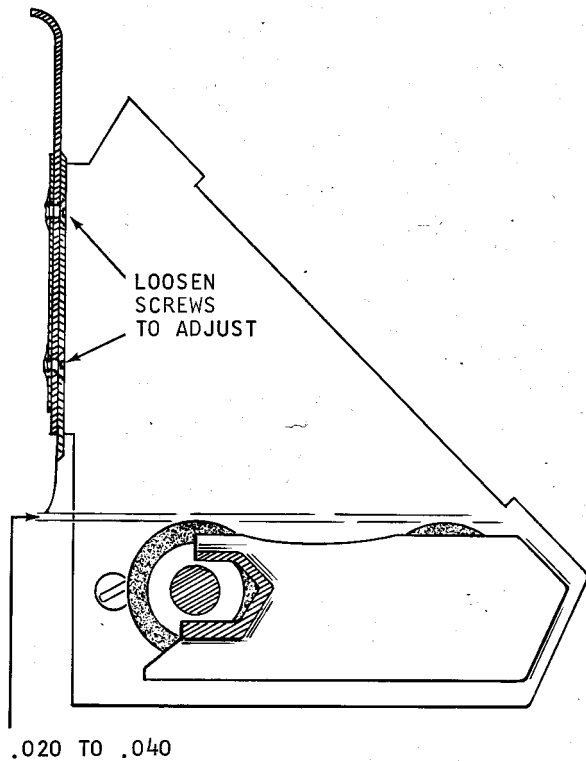

Figure 15. Magazine Throat Clearance

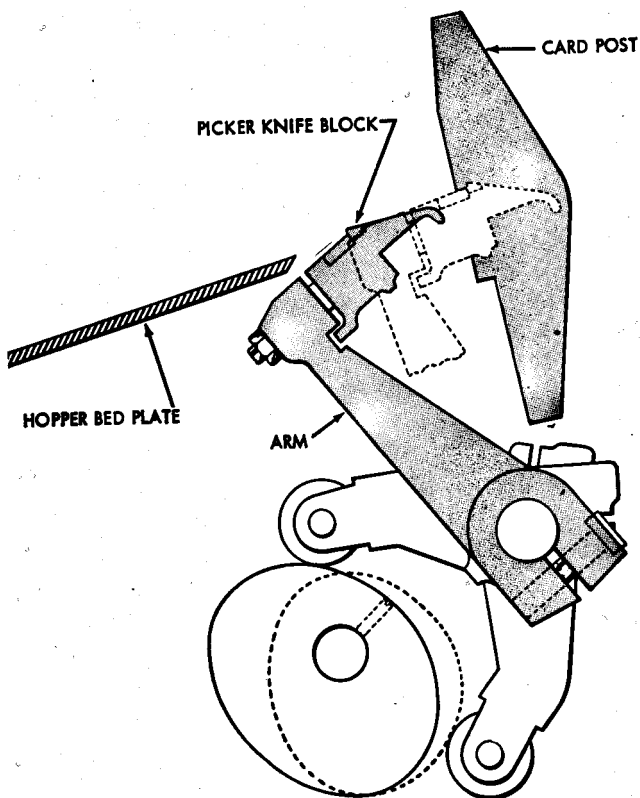

Figure 16. Picker Knives

## Hopper and Picker Knives

### Principles of Operation (Figure 16)

After cards arrive from the file feed to the hopper, the picker knives provide the means of moving the cards from the hopper into the first set of feed rolls. A picker knife cam assembly is located on a shaft driven under clutch control. Two cam follower arms are clamped to an adjacent shaft and causes it to oscillate. Two picker knife arms, also clamped to this shaft, move the picker knife blocks.

The picker knives travel in an arc and not in a flat plane parallel to the card line. For this reason, to obtain the best possible feeding conditions, the knife blocks must travel evenly through the same arc. The knife blocks are factory adjusted and should never be changed. Adjustments must be made by moving the picker knife arms on the shaft.

Each picker knife block is fixed on its arm. Two carballoy pieces are inserted in the block surface to resist wear. The inserts are ground to specifications for knife projection and replacement of the picker block is required when the insert becomes worn.

### Adjustments

1. Position the picker knife cam followers for a maximum of .004" clearance over the entire periphery of the cams, without binding.
2. Shim the hopper posts on the mounting bar for a clearance of .010" to .015" between the hopper posts and a pack of cards resting against the throat knife. (The file feed front jogger must be adjusted first).
3. With a clearance of .062"  $\pm$  .005" between the rear hopper side plate and the rear side frame, adjust the front side plate for .016" to .021" over the length of the card. NOTE: This adjustment should result in cards centered between the rails in the transport area ( $\frac{5}{16}$ "  $\pm$   $\frac{1}{32}$ " from the front rail).
4. Adjust the hopper back plate .020" to .025" clearance to the hopper bed plate (Figure 17).
5. Position the feed knife arms evenly on the shaft so that the feed edge of the picker knife block travels .020" to .030" beyond the trailing edge of a card, when the card is held against the hopper posts.
6. The throat roller must be positioned so that the step indicating the center line of the roller is lined up with the throat knife face.
7. The throat opening should be .0095" GO and .0105" NO-GO.
8. Time the picker knife cams to feed a card so that the trailing edge of a card aligns with the face of the throat knife at  $75^\circ \pm 1^\circ$ . To adjust proceed as follows:
  - a. Loosen the clamped hub on the picker knife

cam shaft pulley and rotate the cam shaft to obtain correct timing.

- b. Check timing of RLCB's and brushes.

## Card Guides

### Adjustments

1. Position the first lower card guide for .005" to .015" below the card line. Position the second lower card guide for .015" to .025" below the card line. Adjust by loosening the mounting screws in the side frames.

2. Position the removable upper card guide for .020" to .030" clearance to the first lower card guide assembly.

## Card Levers

### Adjustments

1. Make sure all card levers are free of binds.
2. Position all card lever contacts to give a minimum contact travel of  $\frac{1}{16}$ " when the card lever is being operated by a card.
3. Position the card levers and contacts to provide a

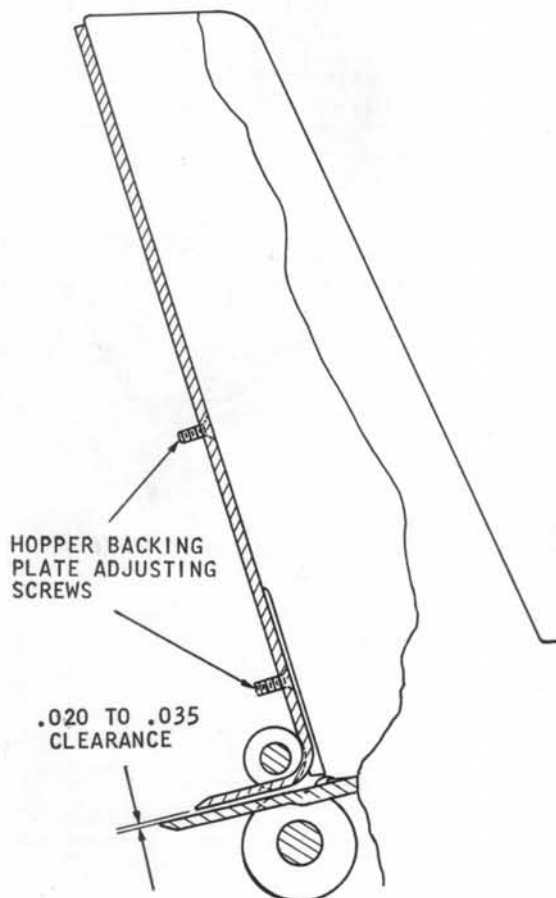

Figure 17. Hopper Backplate Clearance

minimum of  $\frac{1}{64}$ " rise of the N/O contact strap off its support.

4. Adjust the contacts for  $\frac{1}{32}$ " minimum air gap.
5. Time according to timing charts (dynamically).

## Brush Units

### Service Checks

1. When re-inserting brushes, strand breakage will be minimized if the machine is turned over by hand while latching the brushes down.

2. Check for wax build-up between the brushes and the brush separators when reading failures occur. This is evidenced by strands or groups of strands failing to project out of the separator properly.

### Adjustments (Figure 18)

1. Insert the brush unit in the machine and check the brush separator for .012" to .020" clearance to the contact roll. To adjust proceed as follows:

- a. Loosen the four separator holding screws.
- b. Place a straight edge flat on the bottom of one of the brush unit side frames.
- c. Adjust the separator to the straight edge and center the brushes in the separator slots.
- d. Tighten the screw at that end.
- e. Follow the same procedure at the opposite end of the brush unit, and tighten remaining screws.
- f. Check the unit in the machine for correct clearance.

g. If the clearance is incorrect, remove the unit and shift the separator in the proper direction.

2. Loosen the locking screws at either end of the brush unit and shift the block so that the heels of the brushes line up with the scribed line on the separator.

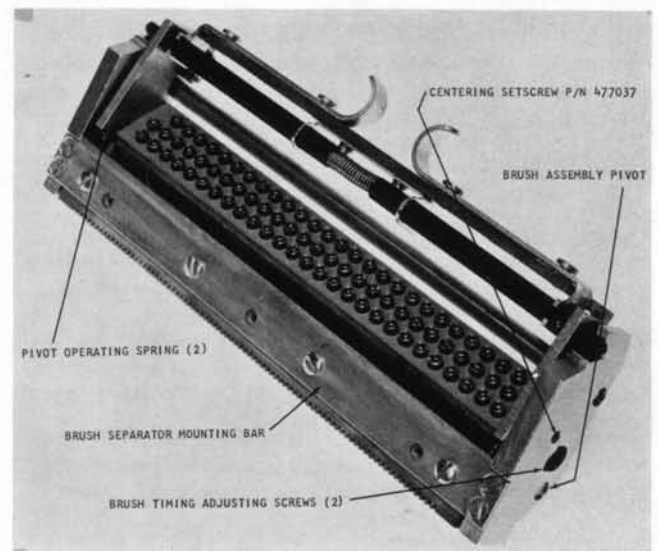

Figure 18. Brush Assembly

3. Adjust the brush unit for correct lateral tracking of the brushes.

a. Center the brush block assembly in its holder by use of the two Allen head set screws in the holder assembly. NOTE: Do not tighten the set screws to a point where they bind the retractable frames.

b. With the brush holder in place, adjust the screws in the machine side frames for correct brush tracking.

c. Allow .003" clearance to prevent binding, when

removing or replacing the brush assembly.

4. Adjust brush assembly card guide for a minimum of .025" clearance to the lower card guide.

### Brush Timing

1. Dynamically time brushes to make by  $3^\circ$  before line of index. No brush should make before  $7^\circ$  before line of index or break before  $10^\circ$  after line of index. NOTE: Timing is accomplished by moving the brushes off the scribed line, NOT by moving the feed knives.

## Transport and Stackers

### Selection Mechanism

#### Principles of Operation

The transport mechanism consists of six continuously running feed rolls that move cards from the feeds to the stackers selected by chute blades. Three of the feed rolls are under control of the read feed, and three are under control of the punch feed. Cards can go into only three of the five stackers from either feed. The stacker into which the card enters is determined by the selection mechanism at each end of the transport mechanism (Figure 19).

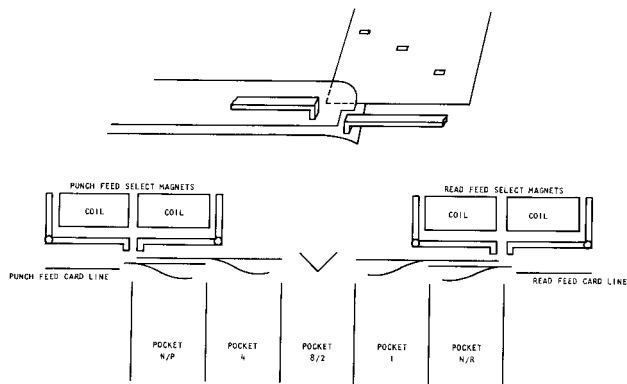

Figure 19. Card Selection Schematic

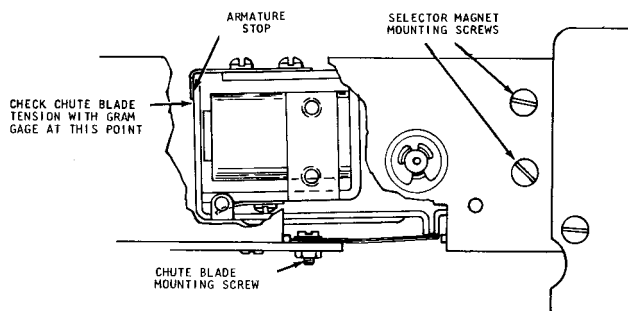

Figure 20. Chute Blade and Selector Magnet Adjustment

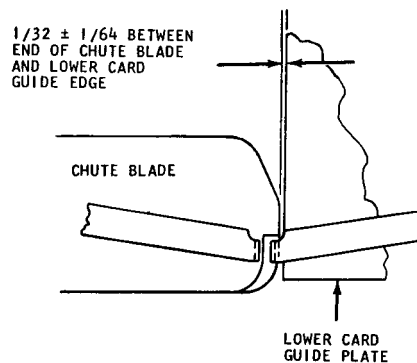

Figure 21. Chute Blade (Top View)

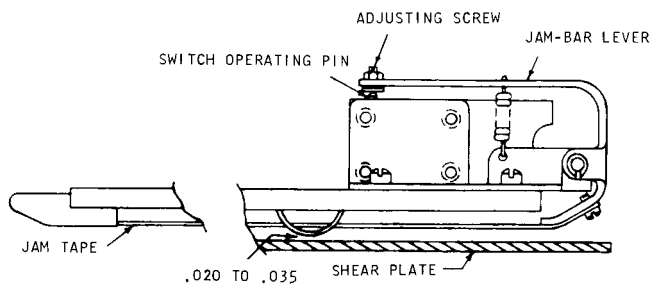

Figure 22. Jam Bar

is bent enough to flex the metal strip causes a switch to operate. The switch causes the machine to stop and turns on the STOP light. A card jam in the feed portion of the machine is detected by other circuits.

### **Chute Blade and Selector Magnet Adjustments (Figure 20)**

1. Lower the control key and indicator light panel by loosening four holding screws and pivoting.
2. With the pocket selector magnet armatures attracted, adjust each armature for  $.035'' \pm .003''$  clearance between the upper part of the stop and armature.
3. Adjust the selector magnet assembly (by use of the mounting screws) to position the chute blades  $\frac{1}{32}'' + \frac{1}{64}'' - 0$  above the card line when the magnets are not energized, and  $\frac{1}{32}'' + \frac{1}{64}'' - 0$  below the card line when the magnets are energized.
4. Adjust the chute blades (use the chute blade mounting screw) for  $\frac{1}{32}'' \pm \frac{1}{64}''$  clearance between the end of the lower chute blade and the lower card guide plate (Figure 21).
5. Chute blade tension should be such that a force of 300-350 grams applied to the 2 or 8 selector magnet armature (at a point just under armature backstop) should hold the armature fully attracted. A force of 150-200 grams should be required to hold select magnet 1 or magnet 4 armatures fully attracted.
6. With a chute blade removed and held on a flat surface, the tab containing the chute blade mounting screw hole should project  $\frac{1}{8}'' \pm \frac{1}{64}''$  above the flat surface.

### **Transport Roll Adjustments**

1. The lower pressure rolls should be centered directly below the upper rolls. This can be accomplished by inserting a .010" feeler gage leaf between the upper and lower rolls and adjusting the lower roll mounting brackets until the feeler gage leaf is parallel to the card line.
2. Tension on the pressure rolls is adjusted by the lower feed roll shaft mounting screws so that a pull of 1.5 lbs. to 2.5 lbs. is required to pull a card strip from between the rolls (upper roll not turning). Tension on the front and rear rolls should be within  $\frac{1}{4}$  lb. of each other. The card must be pulled in the same direction as it is fed. After adjusting, be sure locknuts on the mounting screws are tight. NOTE: Push-pull scale, P/N 9900012, may be used.

### **Jam Bar Adjustments**

1. A jam bar must be positioned for  $.020''$  to  $.035''$  clearance between the formed points and the shear plates over the entire length of the card transport and

at the junction of the jam bar and jam bar lever (Figure 22).

2. The tape must be adjusted so that the switch will be operated with a tape deflection of  $\frac{1}{16}''$ .

## **Stackers**

### **Principles of Operation (Figure 23)**

The stackers used on the 1402 are the radial type. The stacker receives the card from the transport mechanism with the card horizontal. The distance from the top of the guide assembly to the lip of the pivot and lever assembly is less than the length of the card. As a result, the front of the card is held by the card restraining lever, and the rear of the card falls, guided by the guide assembly. The radius of the guide assembly is such that as the rear of the card approaches the bottom, the front falls from the card restraining lever that has been supporting it.

The card stops with the back edge on the card alignment lever and the front edge on the card deck support or card previously stacked. Spring tension supports the card alignment lever until 4 to 6 cards accumulate. Their weight overcomes the spring tension supporting the card alignment lever, and lowers the group of cards into the card pusher slide. The pusher slide oscillating front to back works the bottom of the cards to the front so they are standing against the card deck support. This can continue until the card deck support moves out enough to operate the stacker stop microswitch operating arm, which stops the machine. The card juggler mechanism is driven from either or both the punch and read feeds.

The N/R and 1 stacker joggler are operated by the read feed and the N/P and 4 stacker joggler are operated by the punch feed. The 8/2 stacker joggler is connected to both the read and punch feeds by means of two helical springs and collars so that it can be operated by either feed.

The card levers on the pivot and lever assembly keep the cards from going back into the stacker where they might jam the machine.

### **Stacker Adjustments**

1. Make sure all sliding and pivoting parts move freely with no binds.
2. The space between the pocket separators should be  $3 \frac{5}{16}'' \pm \frac{1}{64}''$ .
3. The pocket separators should be square with transport rails within  $.015''$ .
4. The radial guides should be square with the pocket separators within  $.010''$ .
5. Form the radial guides as shown in Figure 24.

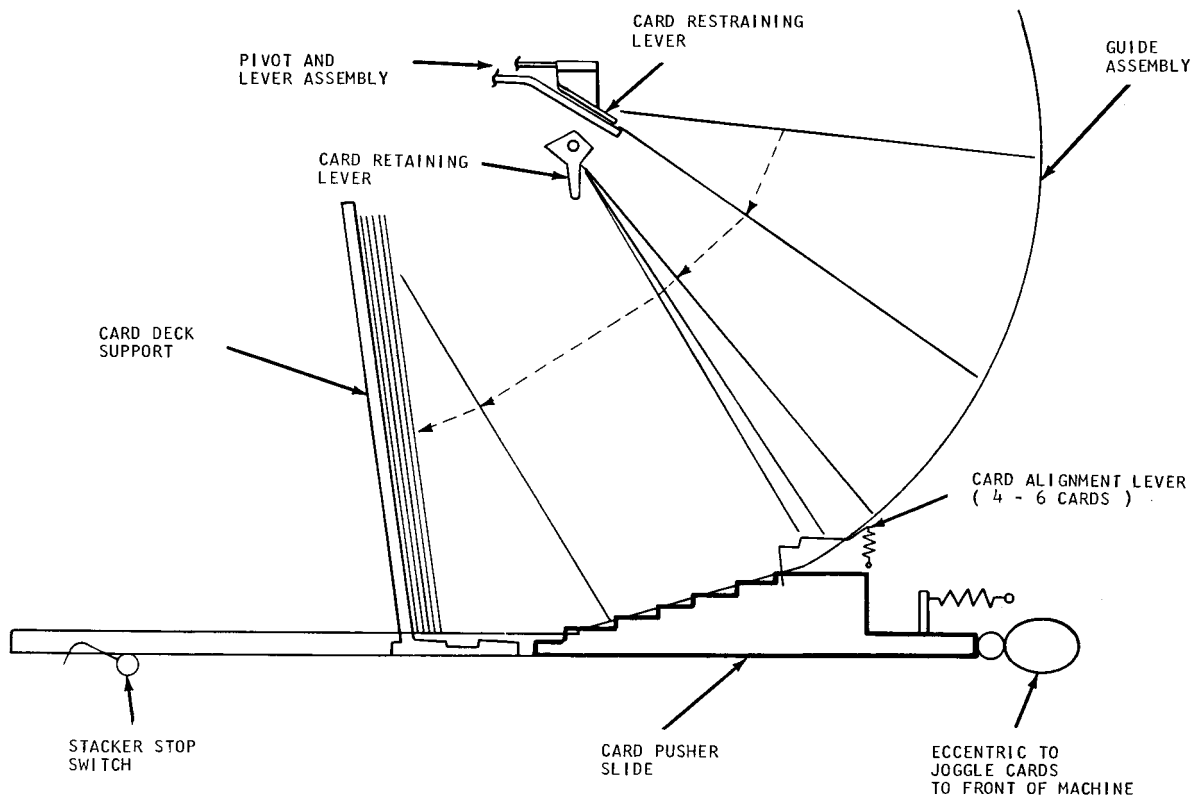

Figure 23. Stacker Schematic

### Stacker Joggler Adjustments

1. The three shafts must be free of binds (align the four bearing bracket assemblies).
2. Maintain  $4.000'' \pm .005''$  between the bases of the two inside bearing brackets (Figure 25).
3. With the center shaft assembly shifted toward the reader feed and the clutch hubs flush with the spring sleeve, adjust the clutch hub (identified by a red dot) for  $.003''$  to  $.005''$  clearance while its spring sleeve is flush against the mating hub.

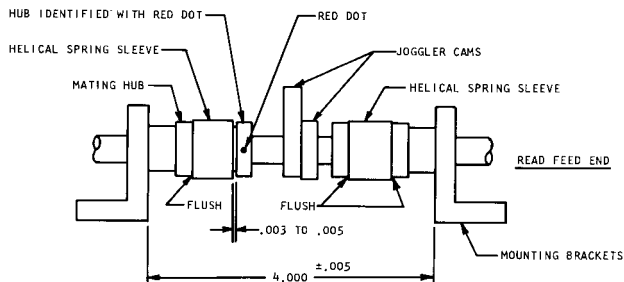

Figure 25. Center Stacker Joggler Assembly

## Punch Feed

### Drive Mechanism (Figures 1 and 26)

A  $\frac{1}{3}$  h.p. motor is used to drive the input idler pulley. Through gears and timing belts, the following are kept continuously running:

1. Timer index
2. Clutch ratchet
3. Geneva assembly
4. Intermittent feed rolls
5. Punch unit drive shaft
6. PACB's
7. PCCB's
8. First feed roll after the punch check brushes
9. Three transport feed rolls
10. Stacker jogglers.

When the punch clutch engages, power is transmitted to the following:

1. Picker knife cam shaft
2. Feed Knives
3. First feed rolls
4. First stepped roll assembly
5. Card aligners
6. Second stepped roll assembly
7. Punch check brush contact roll

## ADJUSTMENT OF STACKER RADIAL CARD GUIDES

MALFORMED RADIAL CARD GUIDES CAN BE A CAUSE OF EXCESSIVE CARD JAMMING. TO ELIMINATE THIS AS A CAUSE, FORM THESE GUIDES TO MATCH THE ILLUSTRATED PROFILE. DO NOT DISTORT THIS PROFILE TO ACCOMPLISH REINSTALLATION. IF MOUNTING SCREW HOLES DO NOT ALIGN, ELONGATE THE UPPER MOUNTING SCREW HOLE TO THE REQUIRED EXTENT BY FILING.

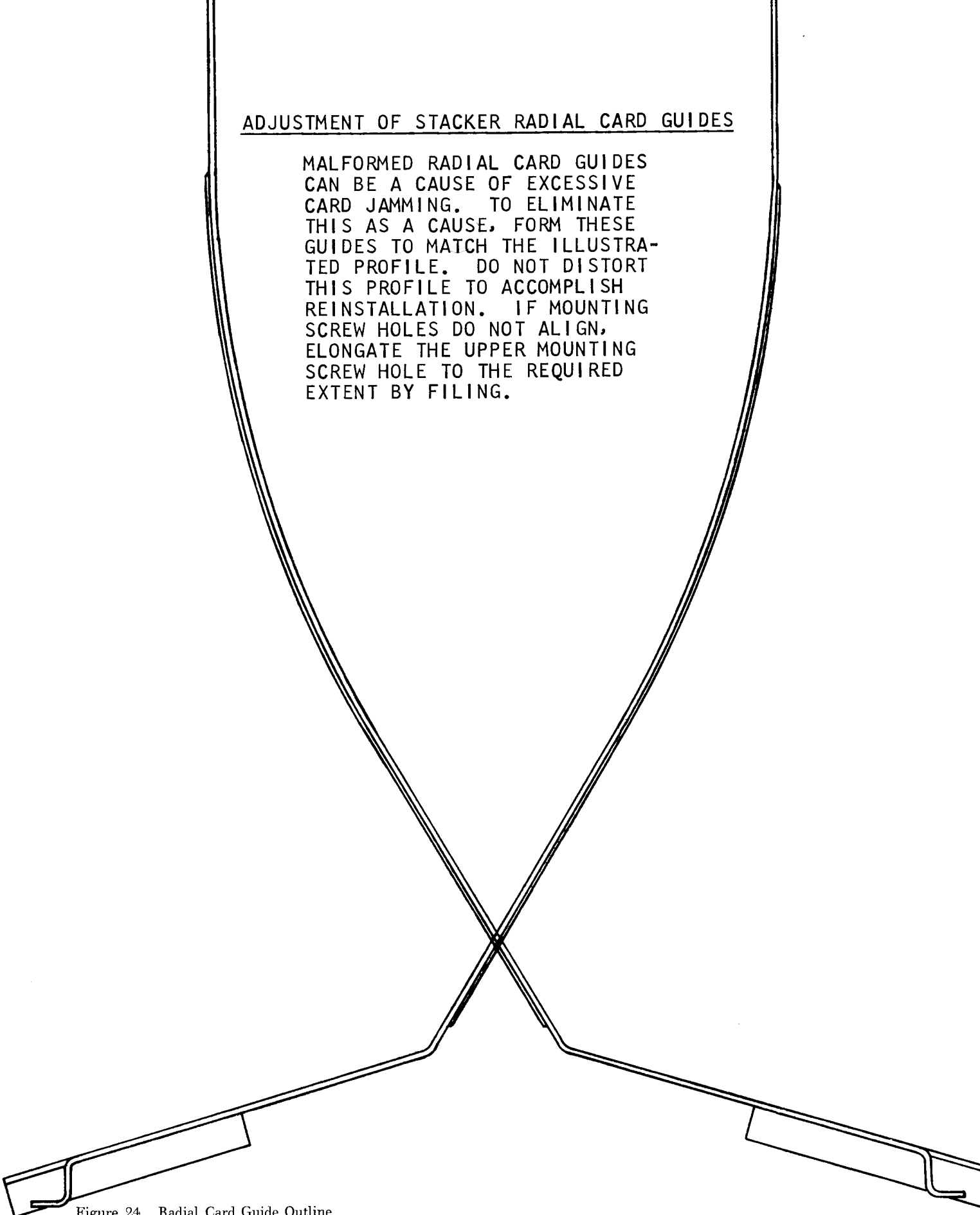

Figure 24. Radial Card Guide Outline

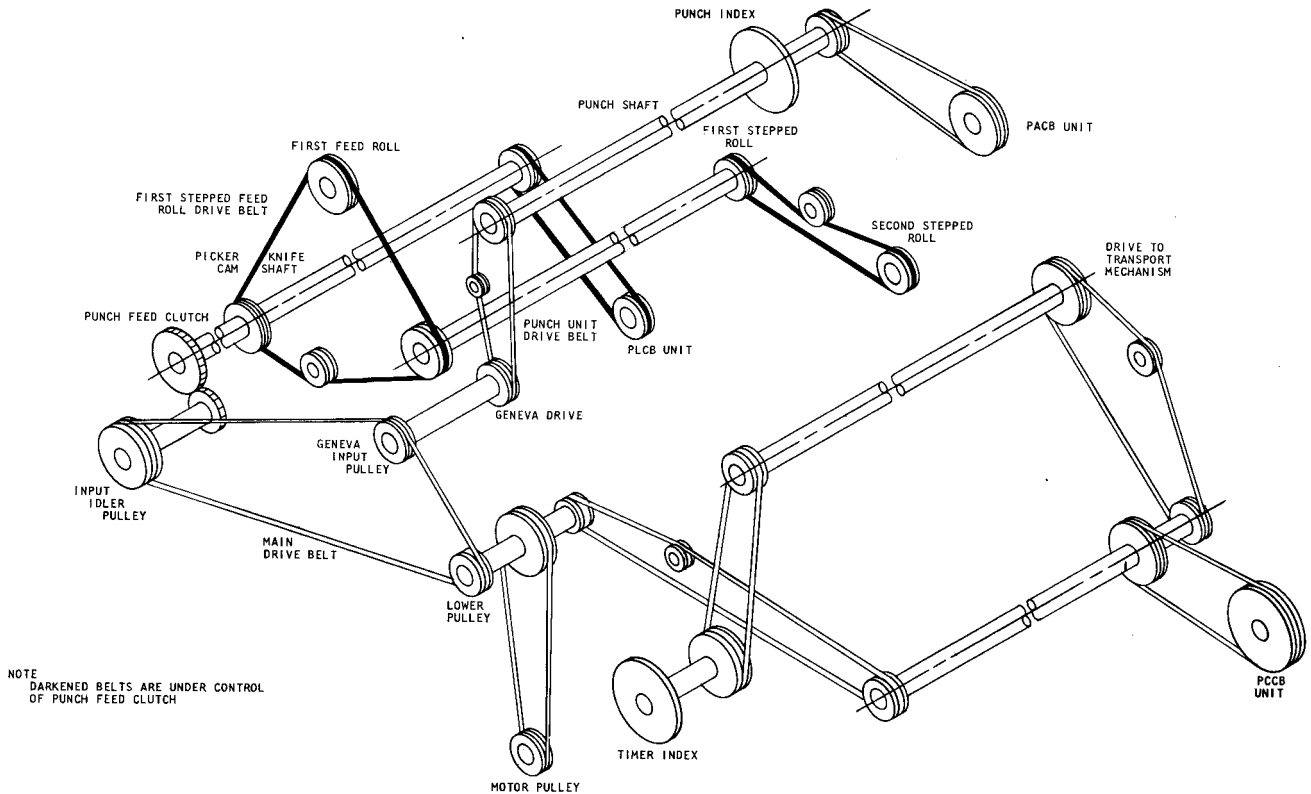

Figure 26. Punch Feed Timing Belts

8. PLCB's

9. Punch feed read brush contact roll (Optional feature).

When the punch clutch latches, the intermittent feed rolls are cammed open so that they cannot feed the card though they continue to turn.

## Punch Feed Clutch

### Principles of Operation

The punch clutch used on this machine is a 4-tooth ratchet type. The clutch pawl can engage at  $315^\circ$ ,  $45^\circ$ ,  $135^\circ$ , or  $225^\circ$ . In order to keep the PCCB's (continuously running) in time with the card and the PLCB's (under control of punch clutch), the PCCB's make and break four times for each machine cycle. Therefore, no matter which tooth the pawl engages in, the PCCB's will give the same timings in relation to the card being fed. The PACB's (high speed continuously running) make and break for each cycle point. The impulses that are required only need to be filtered out by PLCB's.

### Clutch Adjustments

The clutch assembly is pinned at the factory and should not have to be changed. Step 1 would only be performed if a new clutch assembly is installed.

1. Set the clutch so that the latch arm is on the vertical centerline of the picker cam shaft within  $.005''$  (Figure 27).

a. At the same time position the unit sideways so that the keeper is flush with the edge of the dog carrier within  $.010''$  (Figure 28).

b. Form the cam follower arm so that the cam follower is on the middle of the cam surface.

2. Turn the machine to the low dwell on the clutch cam. Trip the clutch and set the adjusting screw for  $.018''$  to  $.030''$  unlatching clearance (Figure 29).

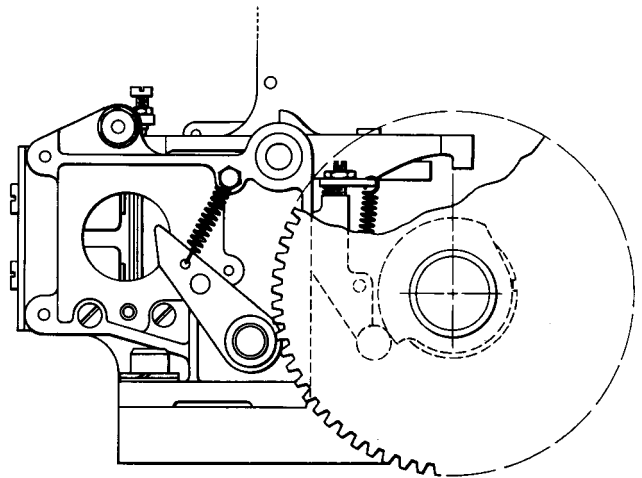

Figure 27. Clutch Position



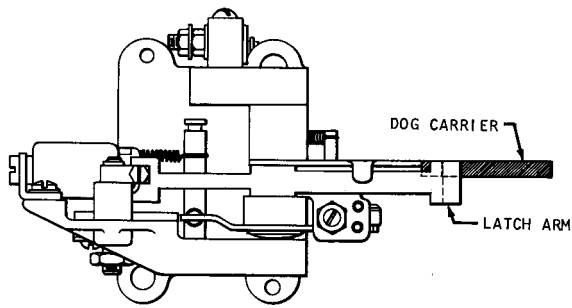

Figure 28. Clutch Arm and Dog Carrier Relationship

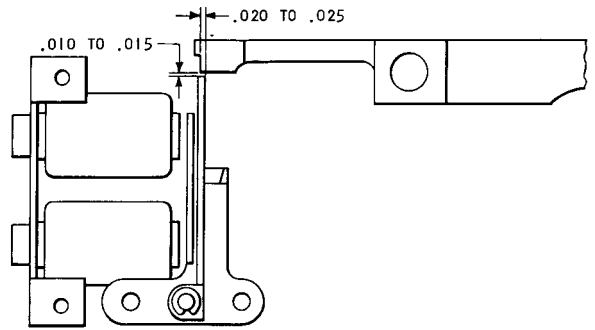

Figure 31. Armature Relatching Clearance and Overlap

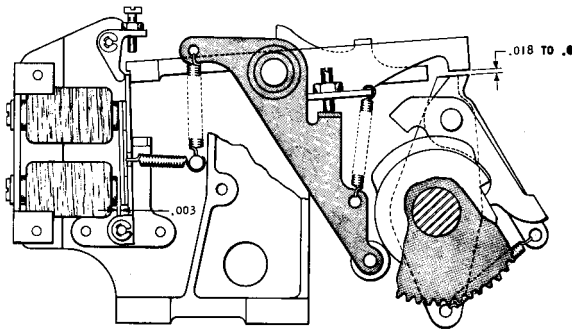

Figure 29. Clutch Unlatching Clearance

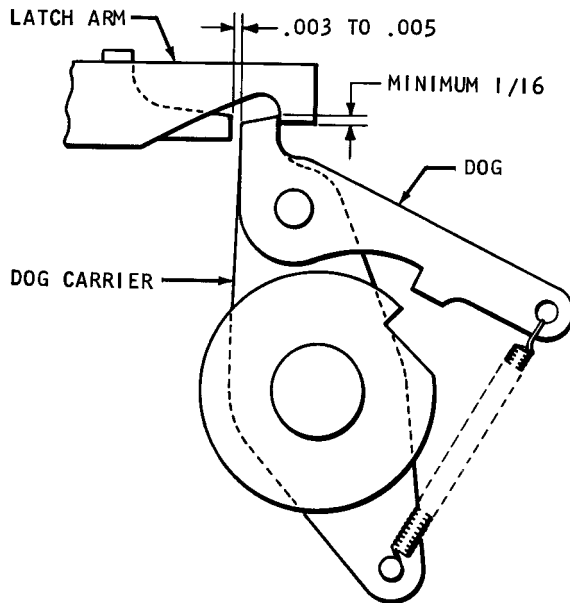

Figure 30. Keeper to Dog Clearance

3. Turn the machine to the high dwell on the clutch cam. Check for a minimum of  $\frac{1}{16}$ " overlap of clutch latch arm on the dog and dog carrier (Figure 30).
  - a. Reposition latch arm if necessary. Check Item 2.
4. Check for .003" to .005" clearance between the dog carrier and the keeper. Peen or stone the keeper to adjust (Figure 30).
5. With the cam follower on the high dwell, position the armature backstop plate horizontally for .020" to .025" overlap of the armature and latch; position vertically for .010" to .015" relatching clearance (Figure 31).
6. Adjust the magnet assembly for .010" clearance between the armature and core nearest the pivot and .025" between the armature and core farthest from the pivot when the armature is latched (Figure 32). This adjustment should give .003" to .005" clearance between the armature and core nearest the pivot when the armature is attracted.
7. The clutch should unlatch with an .008" gage between the armature and core farthest from the pivot point. It should not unlatch with a .010" gage. Re-adjust Step 5, overlap, if necessary.

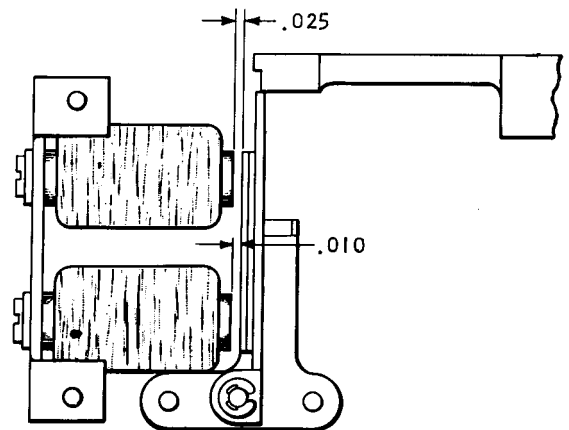

Figure 32. Clutch Magnet Core Clearance

8. With the cam follower on the high dwell, set the armature knockoff for .010" to .012" clearance between the armature and the knockoff (Figure 33).

### Clutch Timing

This adjustment insures that the punch feed index is in time with the punch clutch dog engaging time.

1. Trip the clutch between 230° and 300° and turn the machine manually until the dog engages in the clutch ratchet.

2. While holding the armature in the tripped position, continue turning the machine until the latching surfaces of the clutch latch arm and the dog carrier coincide (Figure 34).

3. At this time the punch feed index should be at 315° ± 1/2°.

a. If the punch feed index is not at 315°, loosen the clamping hub of the index drive pulley and turn the index to 315°.

b. Tighten the clamping hub.

NOTE: If any change is made in the clutch timing, check the timing of all other punch feed units.

### Clutch Ratchet Removal (Figure 26)

1. Remove the main drive belt.
2. Remove the large input idler pulley.
  - a. Remove the screw in the center of the idler pulley stud.
  - b. Pull the pulley off the stud.
3. Remove the screw in the end of the picker knife cam shaft and pull the gear and disc assembly off the shaft.
4. Loosen three set screws and pull the ratchet off the assembly. Do not lose the spacer between the two inside bearings.
5. Install in reverse order.
6. Re-time clutch, geneva and PCCB's.

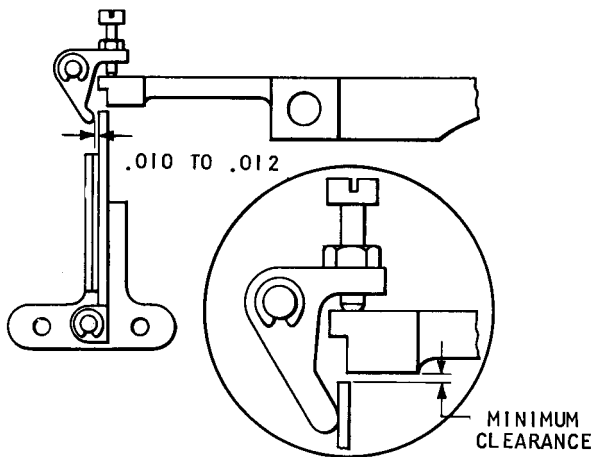

Figure 33. Clutch Armature Knockoff

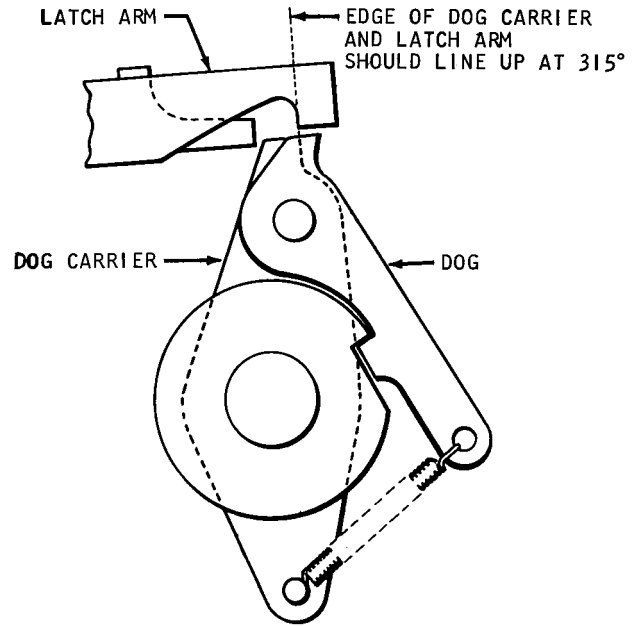

Figure 34. Clutch Timing

### Geneva

#### Principles of Operation (Figure 35)

The geneva operates on the same principle as the genevas in other high speed punches. This geneva, however, is comparatively simple. It consists of a drive disc with two pins to drive two geneva discs. There is one set of feed rolls geared to each geneva disc. These are the only feed rolls that have intermittent action. A feed roll opening device cams these two sets of feed rolls open at clutch latching time so that they will not feed the card when the clutch latches even though they are continuously running.

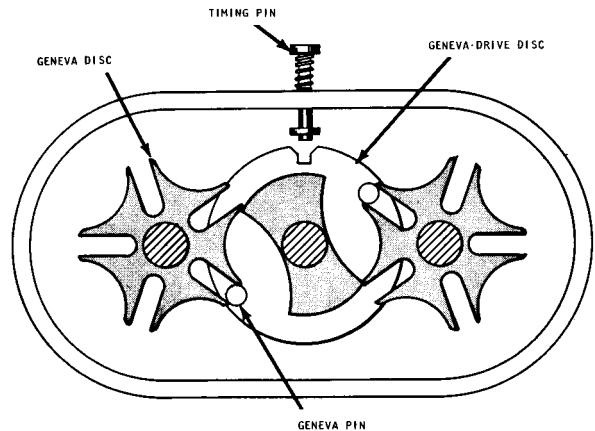

Figure 35. Geneva

When the geneva pins ride into the deep cuts in the geneva discs, the feed rolls are driven by the gears attached to the geneva discs, the cam surface on the geneva drive disc contacts the shallow cuts on the geneva drive discs. When the cam surface is in the shallow cuts of the geneva discs, the intermittent feed rolls are held stationary. The geneva action is repeated every cycle point causing an intermittent movement of the card through the punching station.

### Adjustments

NOTE: Do not repair the geneva housing in the field.

1. Locate the geneva housing on the side frame to produce .001" to .002" backlash in the gears. This setting is very important. If there is too much backlash, punching registration will be off. If there is no backlash, the gears may be damaged.

2. To check for geneva gear backlash:

a. Remove the punch unit.

b. Crank the machine to a point where intermittent rolls are held stationary for punching (approximately 4° before the line of index).

c. Grip an intermittent roll and turn in both directions, checking for a slight wobble. Check both sets of rolls at all 12 digit times.

### Timing

Check the clutch timing before proceeding with this adjustment.

1. The geneva timing pin should seat at 0° and at alternate cycle points throughout a machine cycle.

2. If the geneva is out of time:

a. Turn the machine to 0° on the timer index.

b. Loosen the split hub of the geneva input pulley.

c. Crank the machine until the pin seats and tighten pulley.

d. Check timing of the punch unit and PACB unit.

## Hopper and Picker Knives

### Principles of Operation

Refer to hopper and picker knives of *READ FEED* section.

### Adjustments

1. On machines with adjustable left side aligner, locate the left hopper side plate so that there is .057" to .067" clearance to the hopper sub frame.

2. On machines with the stationary left side aligner locate the left hopper side plate so that a card will clear the left side aligner by .010".

3. The right hopper side plate is adjusted for .008" to .012" clearance over the length of the cards.

a. Check this clearance by placing approximately a 1" pack of cards in the hopper and insert 1 or 2 cards vertically between pack and side plates. One card should be loose; two cards, tight.

b. Make sure hopper side plates are at right angles to the first set of feed rolls.

c. On machines with the adjustable left side aligner check that the card clears the left side aligner by  $\frac{1}{32}$ " to  $\frac{1}{16}$ " with the aligners in the restored position.

4. Position the hopper posts for a clearance of .015"  $\pm$  .002" between the hopper posts and a pack of cards resting against the throat knife

a. Check for a two-card clearance between the hopper posts and the pack of cards.

b. Adjust by loosening screws in either end of the hopper posts mounting bar and shifting the bar the desired amount.

5. Position the throat roller assembly laterally so that the vertical center line of the roller is aligned with the edge of the throat knife. Determine this by the step in the block that indicates the center line of the roller.

6. Position the cam follower arms for no binding condition over the entire periphery of the cams with a maximum clearance of .008" between either cam and follower at any point.

7. Position the feed knife arms evenly on the shaft so that the edge of the picker knife block travels .020" to .030" beyond the trailing edge of the card when the card is held against the hopper posts.

8. The picker knife cam is set to deliver a card to the first feed rolls at  $185^\circ \pm \frac{1}{2}^\circ$ . To adjust proceed as follows:

a. Loosen the cam on the shaft.

b. Engage the clutch and turn to  $185^\circ$ .

c. Turn the cam on the shaft until the feed knives hold the card snug against the first feed rolls.

d. Tighten the cam on the shaft.

## Card Guides

There are four card guides that must be kept in proper relationship to the card line. They are located as follows:

1. First card guide is located just past the first feed rolls. The first upper card guide is removable and is replaced by a brush assembly if the punch feed read feature is on the machine. The first lower card guide is then altered to accommodate a contact roll.

2. Second card guide is located at the first stepped roll.

3. Third card guide is located at the second stepped roll.

4. Punch stacker transport card guide is located between the punch check brushes and the stackers at the sixth feed roll.

## Adjustments

1. The hopper back plate guide should be .008" above the card line.

2. Loosen the first lower card guide tie bar holding screws and shift the tie bar to obtain .012" to .030" clearance between the lower card guide and the hopper back plate guide.

3. The trailing edge of the first lower card guide should be not more than .005" above or .010" below the second lower card guide leading edge.

4. Position the first upper card guide for .012" to .030" clearance to the lower card guide. Adjust by loosening the screws in the mounting bar and shifting the guide to the desired position.

5. Position the second upper card guide for .012" to .030" clearance to the lower guide.

a. Adjust by loosening the tie bar holding screws through side frames.

b. Check to make certain the tip of the forward aligner is below the top surface of lower guide. Adjust by positioning the upper guide because aligners travel in a slot in the upper guide.

.NOTE: Screws mounting this guide to the bar are 8-36, P/N 607694.

6. Position third upper card guide for .012" to .030" clearance to the lower guide. Adjust by loosening mounting bar holding screws and shift the guide to the

desired position.

7. Position the punch stacker transport lower card guide for .015" to .025" below the card line level, determined by the contact roll and the sixth feed roll.

## Aligner Stations and Intermittent Feed Rolls

### Principles of Operation (Figure 36)

As the card passes the first upper card guide, it is picked up by the first stepped roll assembly. The lower roll of the assembly is called a stepped roll, because it has a portion of its circumference cut away. When the high dwell of the stepped roll is opposite the upper roll, the card is fed through the rolls into the first intermittent rolls which are cammed open at this time. When the low dwell of the stepped roll is opposite the upper roll, collars on the end of the stepped roll assembly prevent the stepped roll from contacting the card.

During the time that the card is free from the stepped feed roll and intermittent feed roll, it is aligned to insure correct punching registration. The forward aligners contact the trailing edge of the card and move the card up to the centerline of the punches. At the same time, the card is aligned toward the column 1 end by the side aligners. Card pressure fingers are used at the

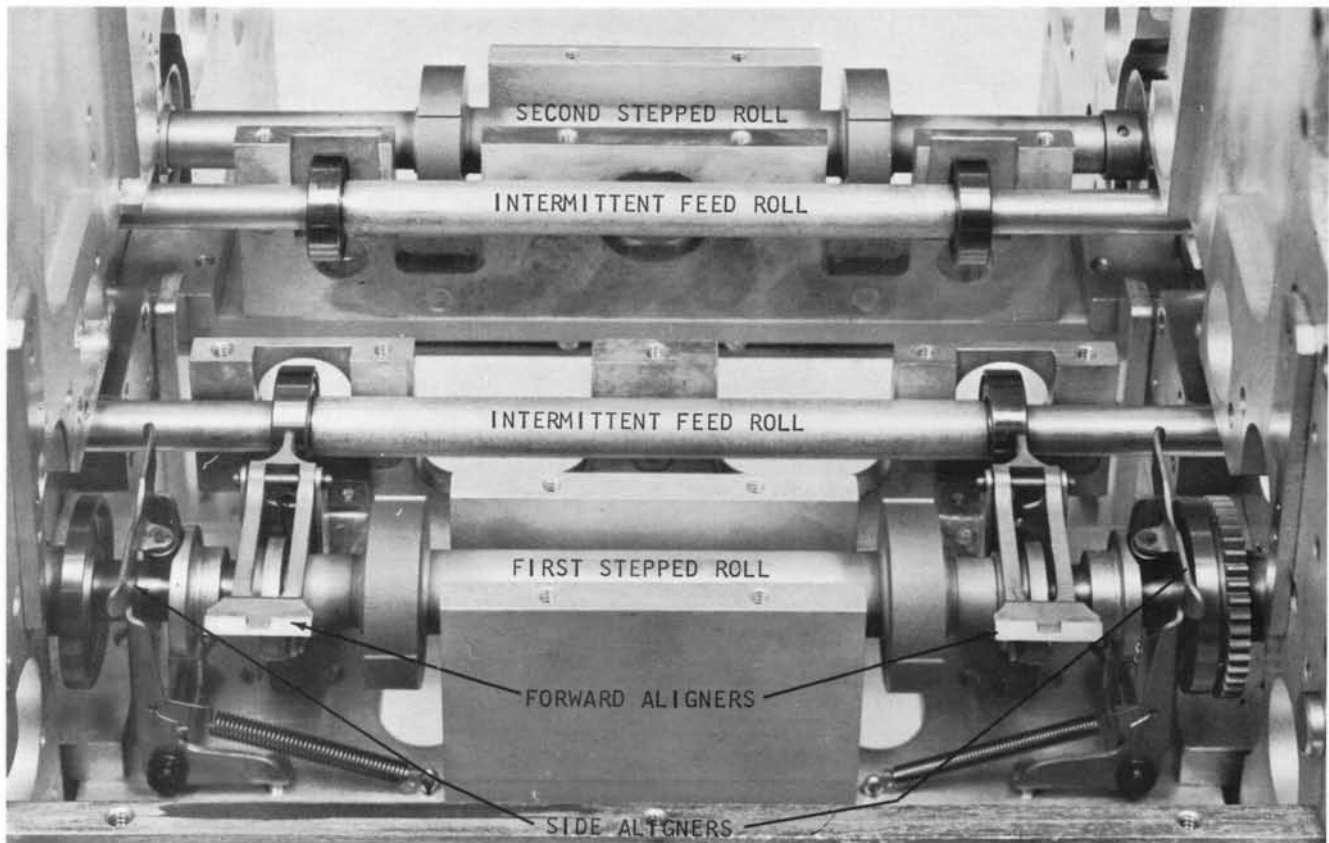

Figure 36. Aligner Station, Stepped and Intermittent Rolls

aligner station to hold the card so it does not snap or buckle.

After aligning is completed, the first intermittent feed rolls close, and they start feeding the card through the punching station. The second intermittent feed rolls are cammed open as the card is fed into them. They then close, just before the card leaves the first intermittent feed rolls. After the second intermittent feed rolls close, the first intermittent feed rolls are cammed open. When the first intermittent feed rolls open, the feeding of the cards through the punching station is under control of the second intermittent feed rolls. The opening and closing of the intermittent feed rolls prevent buckling or snapping of the card at the punch station.

While punching is being completed, the card is fed into the second stepped roll assembly which does not contact the card at this time. The second stepped roll assembly is like the first stepped roll assembly ahead of the aligner station. The second stepped roll contacts the card after the second intermittent feed roll releases the card and feeds it past the punch check brushes into the sixth feed roll. The sixth feed roll will take over control of card feeding when the second stepped roll comes to the low dwell on its circumference. After card reading the card is under control of the transport and selection mechanism. Refer to *Read Feed* for the transport and stacker operation.

### Timing Check At Punch Station

NOTE: This procedure is merely a method of checking the timing of forward aligners, first stepped feed roll, and first intermittent feed roll. It should not be used as an adjustment procedure. The various timings are not checked by this procedure in the sequence in which the adjustments should be made. The procedure for making the adjustments in proper sequence follows this timing check.

1. Remove the punch unit and its drive belt.
2. Latch the die into position.

NOTE: A card guide tool will be furnished with the new redesigned die and stripper.

3. Insert gage (P/N 608183) in place of the punch

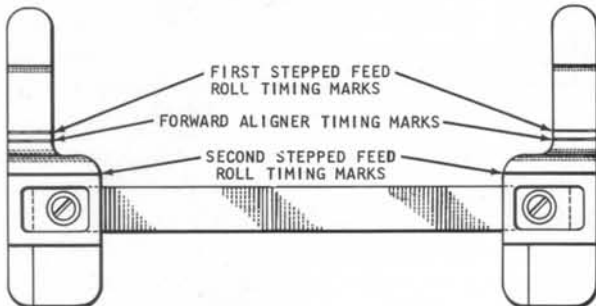

Figure 37. Gage 608183

unit to act as a guide (Figure 38).

4. Feed a card under power for two card cycles.
5. Disconnect the power from machine.
6. Trip the clutch and turn the machine manually until the clutch engages.
7. Continue turning with the clutch engaged until the machine index is at  $339^\circ \pm 1^\circ$ . At this time the leading edge of the card should not have moved past the "first stepped feed roll timing marks" on the gage (Figure 37).
8. Continue turning the machine and check to see that the card finishes forward aligning to within .005" of the "forward aligner timing marks" on the gage at  $351^\circ$  (Figure 37). This second check makes certain that the card is properly aligned at the time the intermittent roll closes.

9. At  $355.5^\circ$ , the first intermittent roll should have closed to a point where it applies a very light drag evenly over the full length of the card.

NOTE: If any of these timings are found to be incorrect, the following sequence should be followed in making the adjustments.

### Forward and Side Aligner Adjustments

1. Open the roll opening device.
2. Remove the gage and insert a card between the feed rolls from the punching area, against the forward aligners.
3. Raise the roll opening device.
4. Re-install the gage, P/N 608183, in the area where the punch unit was removed (Figure 38).
5. Trip the clutch and turn the machine manually until the forward aligners are at their forward limit of travel,  $351^\circ$ .

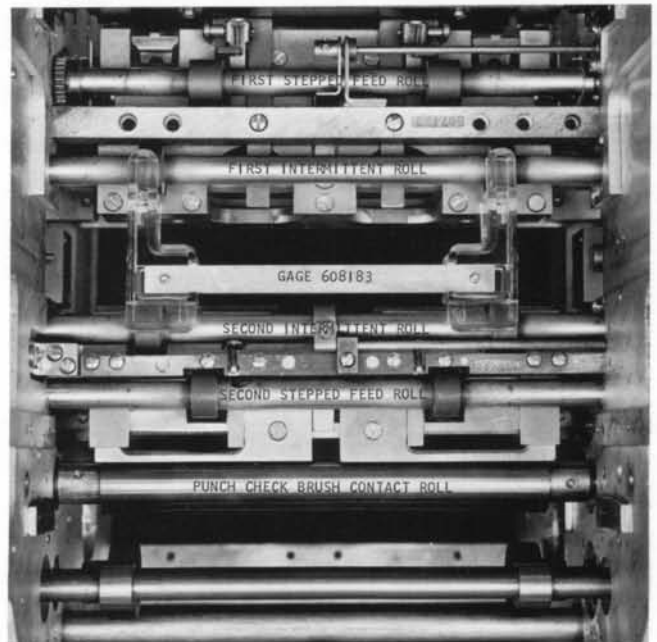

Figure 38. Position of Gage at Punch Station

6. Adjust the forward aligners to position the card evenly within .005" of the "forward aligner timing marks" on the gage (Figure 37). Adjust each forward aligner by loosening the screws in the locking block just enough to allow turning the adjusting screw with an Allen wrench (Figure 39). The locking block serves as a support for the adjusting screw and adjustment cannot be made accurately if the block is loosened too much.

7. Keeping the machine at 351°, loosen the left side aligner lock nut and turn the adjusting screw to position the aligner 37/64" from the inside of the left side frame (Figure 40). Tighten the lock nut. NOTE: This step is only necessary on machines with an adjustable left side aligner.

8. At 351°, adjust the right side aligner to just touch the card.

9. Check both side aligners for 1/32" minimum clearance to a card when the side aligners are fully restored.

### First Stepped Feed Roll Timing

Adjust the aligners before proceeding with this adjustment.

1. Loosen the split hub of the input pulley to the first stepped feed roll.
2. Open the roll opening device.
3. Engage the clutch and turn the machine to 339°.
4. Turn the stepped roll to a point where the forward aligners just start to move toward the rear of the machine.
5. Remove the gage; slide a card between the feed rolls from the punching area against the forward aligners.
6. Raise the roll opening device.
7. Replace the gage, P/N 608183, into position.
8. Turn the stepped roll in normal direction of rotation until the leading edge of the card coincides with the first set of marks on the gage.
9. Tighten the split hub of the input pulley to the first stepped feed roll. Re-check that the leading edge of

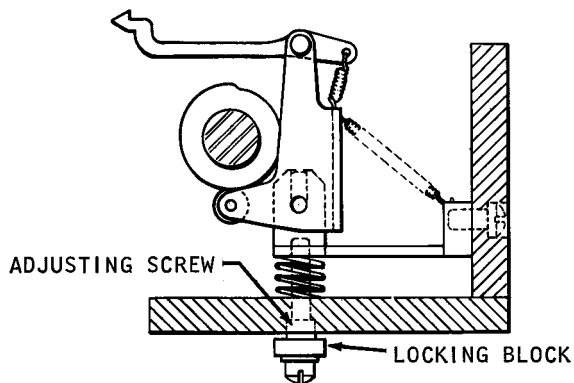

Figure 39. Forward Aligner Adjustment

the card does not pass the "first stepped feed roll timing marks" on the gage at 339°.

### First Intermittent Feed Roll Timing

The first stepped feed roll must be properly timed before adjusting the closing time of the first intermittent feed roll.

1. With the clutch engaged, turn the machine to 355.5°.
2. Adjust the eccentrics\* at each end of the intermittent feed roll shaft so that there is a light drag evenly over the full length of the card (Figure 41). Keep the high side of the right and left eccentrics in the same relative position as indicated by spot marks on eccentric bushings and feed roll opener arms.
3. Check the timing of the second stepped roll and second stepped intermittent roll after adjusting the first intermittent feed roll. If the procedure is followed correctly, the relationship between the two will not be disturbed.

### Side Aligner Removal

1. Remove punch unit from machine.
2. Remove the geneva (do not remove locator blocks).
3. Remove the die card lever.
4. Remove the upper card guides and card guide mounting bar in the aligning station.
  - a. Remove six screws holding card guides to the mounting bar and slide the guides toward the front of the machine.
  - b. Remove two screws from each end of the card guide mounting bar and lift bar out.

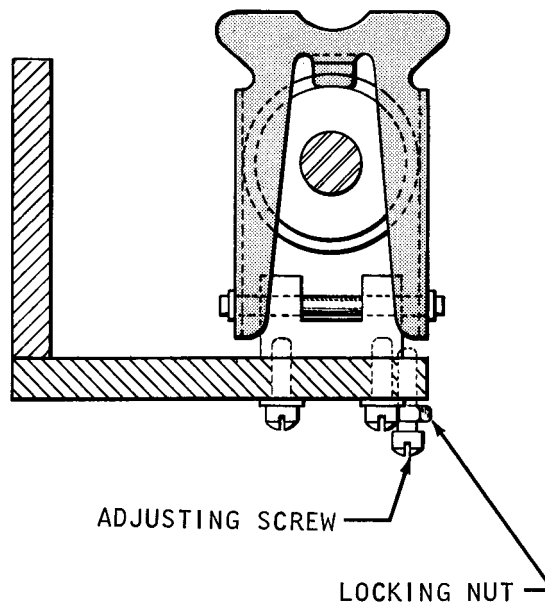

Figure 40. Side Aligner Adjustment

5. Remove the second upper feed roll.
6. Remove the lower card guides in the aligning station.
7. Remove the side aligner.
  - a. Disconnect the spring from the aligner to be removed.
  - b. Pull the pivot pin and lift the aligner out.
8. Replace in reverse order.

#### **Forward Aligner Removal**

- 1.-6. Follow first six steps of the *Side Aligner Removal*.
7. Remove the first intermittent feed roll shaft.
  - a. Remove the first intermittent feed roll hangers.
  - b. Work the intermittent feed roll shaft out left side of the machine.
8. Remove the forward aligner adjusting screw lock plates and adjusting screws for both aligners.
9. Remove third upright card guide support.
  - a. Remove four screws up through bottom of bed plate.
  - b. Forward aligners are mounted to this upright and will come out with it.

#### **First Stepped Feed Roll Removal**

1. Remove side aligners.
2. Remove two screws and one pin from each end of the bed plate.
3. Drop the card guide supports and forward aligners out bottom of roll opening assembly.
4. Remove the pulleys and the cam follower arms from the right side of the machine.
5. Remove two screws from the card bed plate. These are on the right end under the second intermittent roll.
6. Remove the right side frame from the roll opening device.
7. Remove the pulley and the bearing retaining screws from the left end of the stepped roll. If the roll is being replaced, bearings are furnished with a new shaft.

#### **Fourth or Fifth Upper Feed Roll Removal**

1. Remove the punch unit from machine.
2. Remove geneva (do not remove locator blocks).
3. Remove the belt and pulley from the right end of the second stepped feed roll.
4. Remove the bearing and hanger from the left end of the fifth lower roll and the hanger from the right end.
5. Remove the upper card guides and the card lever in second intermittent station.
6. Remove the screws from the "L" bracket and both ends of the card guide mounting bar and remove the "L" bracket and the mounting bar.

\*The eccentrics on the first and second intermittent feed rolls should be adjusted only if necessary.

7. To remove the fourth upper roll:
  - a. Remove bearing retainer screw from left end of shaft.
  - b. Tap shaft to the right out the left-hand bearing. The right-hand bearing slips out of the side casting.
8. To remove the fifth upper shaft, tap shaft to right.

#### **Timing Check At Punch Check Brush Station**

NOTE: Check the aligner adjustment and timing before proceeding. The second stepped feed roll is adjusted to deliver a card at the punch check brush station in time for proper reading. The second intermittent feed roll is then adjusted for even opening on both lobes and to compensate for second stepped roll adjustments in connection with punch check brush timing. NOTE: This procedure is for checking the timing of second stepped feed roll and second intermittent feed roll. Do not use as an adjustment procedure.

1. Feed a card 3 cycles under power.
2. Disconnect the machine power.
3. Remove the punch check brushes.
4. Install gage P/N 608183 in place of brushes (Figure 42).
5. The leading edge of the card should coincide within .005" of the "second stepped feed roll timing marks" on the gage (Figure 37).

#### **Second Stepped Feed Roll Timing**

NOTE: If the second stepped feed roll is out of time, follow Steps 8 and 9 to re-time. When the roll is removed or a belt has broken, follow Steps 1 through 9 to re-time.

1. Remove the punch check brushes.
2. Insert gage (Figure 42).

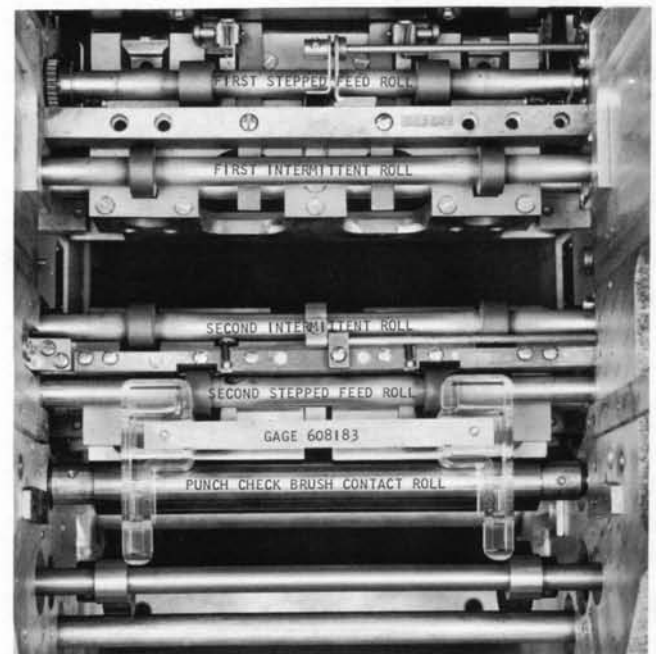

Figure 42. Position of Gage at Brush Station

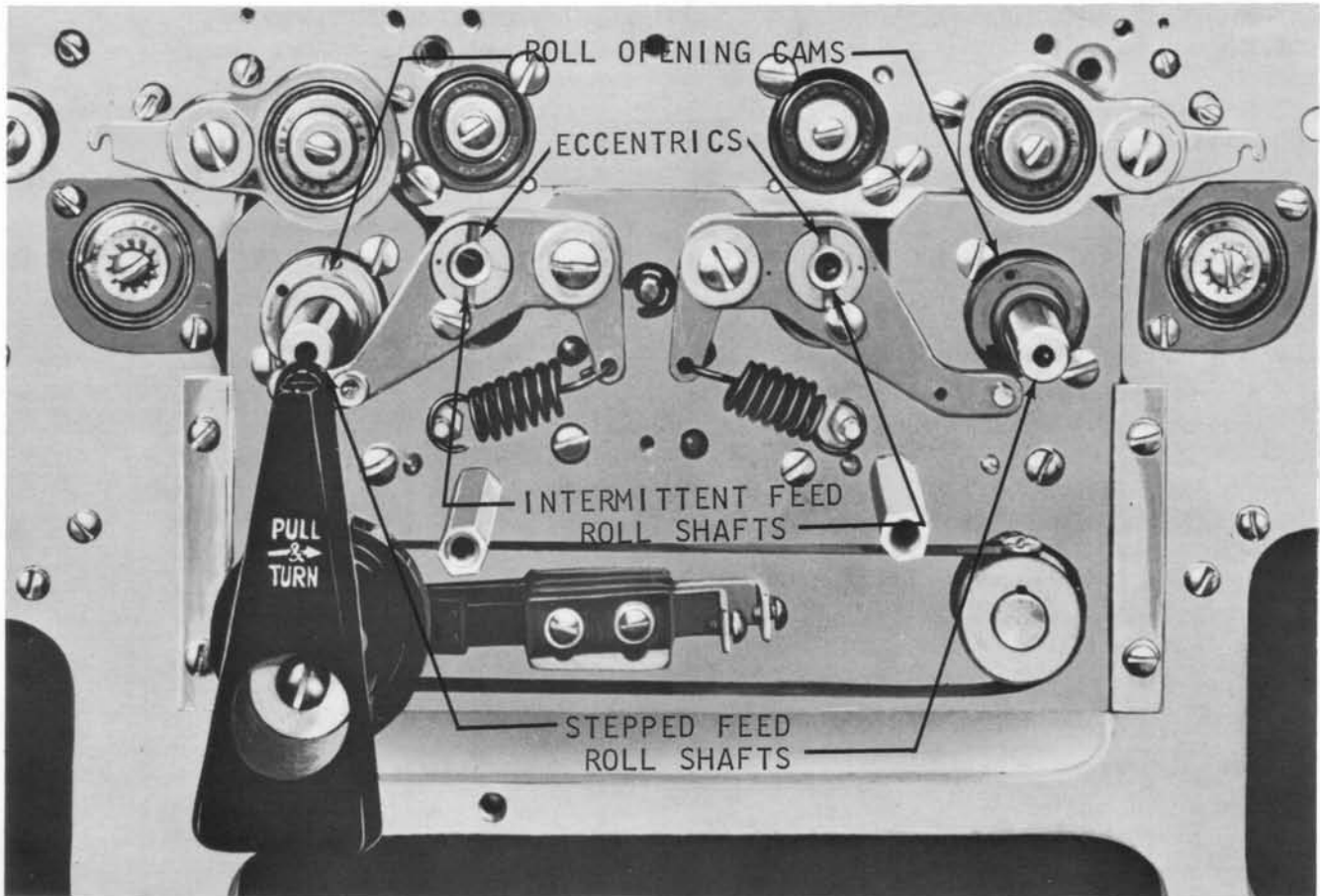

Figure 41. Roll Opening Device

3. With the second intermittent feed roll closed, loosen the pulley on the end of the second stepped feed roll shaft.

4. Manually feed a card through the machine to  $288^\circ$  of the third feed cycle.

5. With the index at  $288^\circ$  rotate the second stepped feed roll until the leading edge of the card coincides with the marks on the gage (Figure 37).

6. While holding the second stepped roll, turn the machine to  $315^\circ$ .

7. Tighten the pulley on the left end of the second stepped feed roll shaft. This is an approximate setting and will probably need slight re-adjustment.

8. Check the adjustment by following the above timing check procedure outlined above.

9. If the leading edge of the card does not coincide within  $.005''$  of the "second stepped feed roll" timing marks on the gage (Figure 37), loosen the pulley on the second stepped feed roll shaft and rotate the roll in the proper direction to line up the leading edge of the card with the marks.

### Second Intermittent Feed Roll Timing

1. Adjust the second stepped feed roll before adjusting the closing time of the second intermittent feed roll.

2. Engage the clutch and crank machine to  $280^\circ$ .

3. Open the roll opening device.

4. Insert the card between the second intermittent rolls.

5. Adjust the eccentrics\* at either end of the second intermittent feed roll shaft so that the rolls hold the card tight until  $284^\circ$  and release the card by  $288^\circ$ .

6. Make sure the eccentrics are adjusted evenly at both ends.

### Second Stepped Feed Roll Removal

1. Remove fifth upper feed roll (Refer to *Fifth Upper Feed Roll removal* procedure).

2. Remove the lower card guide between the second intermittent and the second stepped feed roll.

3. Remove four screws in bed plate.

4. Remove two screws and two dowels from the bed plate mounting block located under the first stepped roll and roll opening device.

5. Remove the right side frame on the roll opening device.

6. Remove the cam and pulley from the left end of stepped roll shaft.

\*The eccentrics on the first and second intermittent feed rolls should be adjusted only if necessary.



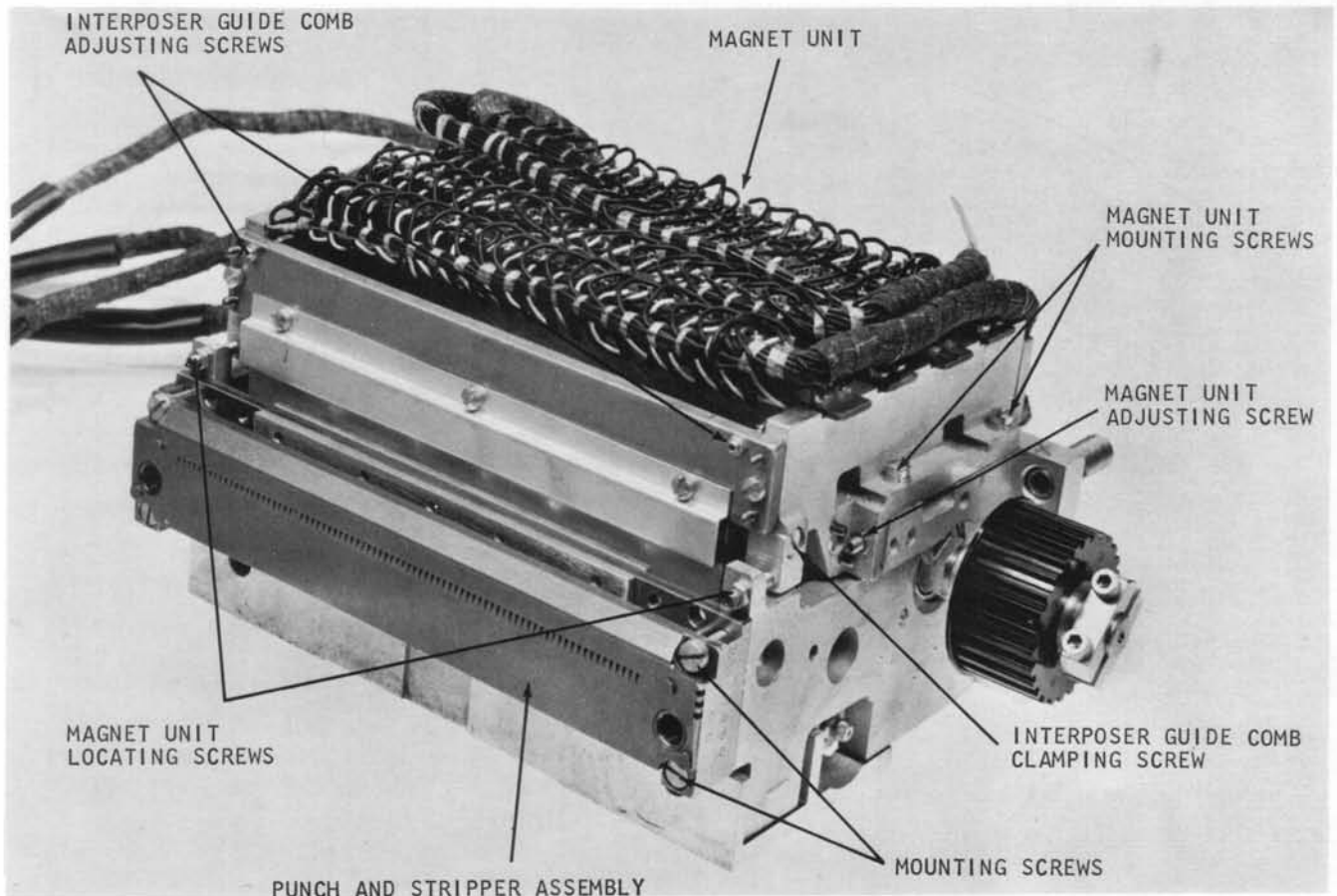

Figure 43. Punch Unit

7. Pull the stepped roll through the left side.
8. Re-assemble in reverse order.
  - a. When replacing the card guides between the fourth and fifth upper rolls, the guides must be laid in place; then the mounting bar is put in place and screwed to the guides.
  - b. Check for .012" to .030" card clearance between the upper and lower guides.

## Roll Opening Device

### Principles of Operation (Figure 41)

The two stepped rolls, the two lower intermittent rolls, and the die assembly are mounted on one assembly called the roll opening device. This assembly may be lowered to facilitate removal of card jams. The roll opening device should also be lowered when removing or inserting the die assembly. The locating blocks for the die are in this frame which makes die removal and insertion much easier.

The handle on the left side of the machine is pulled out and turned clockwise to lower the device and counter-clockwise to raise the device. An electrical contact interlocks the roll opening device so that the device must be in its UP position before the machine will run.

## Brush Units

(Refer to *Brush Units* of *READ FEED* Section).

## Punch Unit

### Principles of Operation

The entire punch unit (Figure 43) can be easily removed from the machine for servicing. It can be separated into two main assemblies as follows:

1. The drive unit (Figure 44)
2. The magnet unit (Figure 46).

The drive unit can be further divided into the following units:

1. Cam shaft unit
2. Punch bail and setup bail cam follower assembly
3. Die and stripper assembly.

The cam shaft unit consists of a cam shaft and four sets of complementary cams.

The punch bail and setup bail cam follower assembly consist of:

1. A punch bail and two sets of cam follower arms.
2. An interposer setup bail and two sets of cam follower arms.

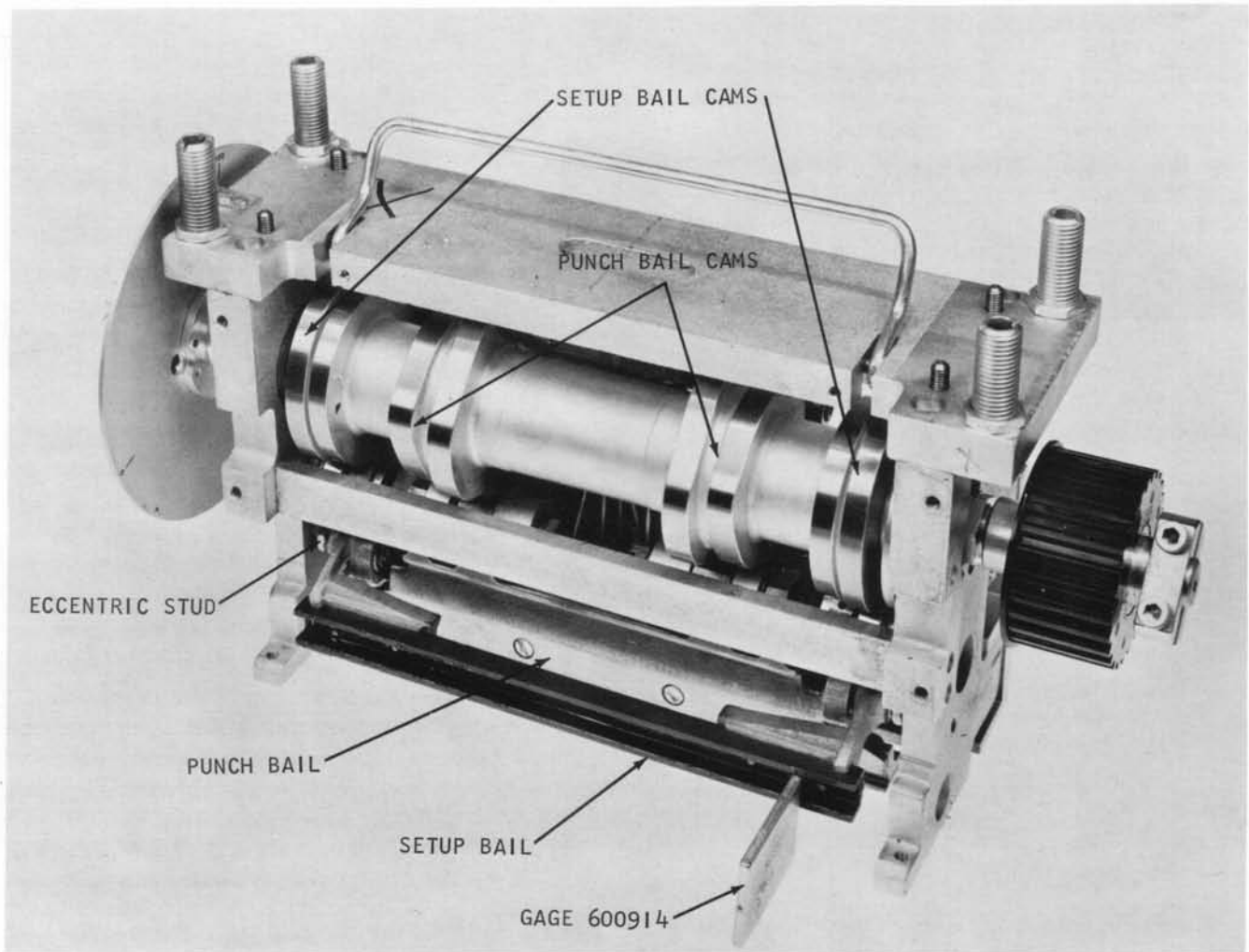

Figure 44. Drive Unit

The punch magnet unit consists of 80 magnets, latches, interposer links, and interposers. The magnets are connected through miniature multi-terminal connectors to the machine circuits.

The cam shaft in the punch drive unit operates continuously when the motor is running. The three-lobed cams operate the interposer setup bail and punch bail three times on each revolution of the punch cam shaft. The punch cam shaft makes  $1333 \frac{1}{3}$  revolutions per minute.

The interposer bail is a U-shaped channel. A projection on each of the 80 interposer links ride in the channel (Figure 47). As the interposer setup bail moves down, all the interposer links move down, carrying with them the 80 latches. This pulls each armature against its yoke. If punching is to take place, the magnet is energized at this time. Because the armature did not have to be attracted electrically, very low current is required to keep the armature sealed against its yoke. For this reason the unit is sometimes referred to as a "no-work" punch unit.

When the interposer setup bail moves up, the magnet just energized keeps its latch in the DOWN position. Because the latch is stationary, the upward movement of the interposer setup bail causes the interposer link to pivot, extending the interposer between the punch bail and the punch.

The movement of the punch cam shaft then causes the punch bail to move down. Only those columns are punched that have the interposers between the punch bail and the punch. When the punch bail pushes the interposer down, the interposer is clamped between the punch and the punch bail. With this arrangement, the magnet can be de-energized while the punch is going down rather than waiting until the completion of the punching operation.

As the punch bail returns, the interposer is free to be restored by spring tension. On the return stroke of the punch bail, the punch is positively restored by the projection on the punch bail.

On machines with the redesigned die and stripper, the only difference is that the die assembly locks into

the stripper rather than the roll opening device (Figure 48). Turn and pull down on the handle to remove the die; push up and turn the handle to insert the die.

### Cam Follower Assembly Adjustments (Figure 44)

1. Remove the punch unit from machine.
2. With the punch unit at room temperature, adjust so that a .002" feeler gage, when placed between the cam followers listed below and their respective cam surfaces, experiences moderate drag at the tightest point as the cam shaft is rotated through one revolution.
  - a. Punch bail complimentary (top-inside) cam followers.
  - b. Setup bail complimentary (top-outside) cam followers.
  - c. Punch bail active (bottom-inside) cam followers.
 This adjustment does not apply to the setup bail active (bottom-outside) cam followers because the 80 latch springs force these cam followers to ride tight against their cam surfaces.

3. With the cam followers adjusted to the .002" feeler gage, check to see that a .005" feeler gage will not pass freely between any cam follower and its respective cam surface at *any* point around the cam circumference. If this .005" adjustment cannot be met, check to see if the punch marks on the eccentric studs are up (these studs can be interchanged by mistake, in which case the punch marks would be down, making it impossible to adjust the followers properly) (Figure 45).

### Cam Follower Assembly Removal

1. Remove the punch unit from the machine.
2. Remove the punch and stripper assembly.
3. Remove the magnet unit.
4. Remove the two dowel pins in the cam follower mounting plate (Figure 45).
5. Remove the four mounting screws (Figure 45).
6. Separate the cam follower assembly from the punch unit.
7. Assemble in reverse order.

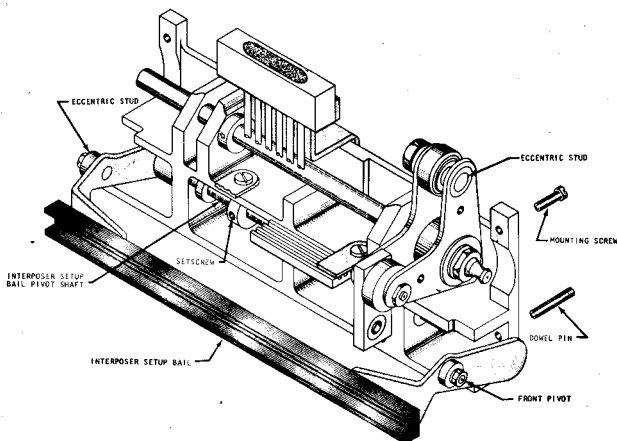

Figure 45. Cam Follower Unit

### Service Checks

With the cam follower unit removed from the punch unit check:

1. That the four collars on the pivot shaft are tight against inner race of the pivot bearings.
2. That set screws holding cam follower pivot shaft, interposer bail pivot studs, and interposer bail pivot shaft are tight.
3. That nuts on all cam follower shafts and interposer bail pivot studs are tight.
4. For wear, fretting corrosion, or lack of lubrication of all parts.

### Cam Follower Assembly Timing

1. Use timing rod P/N 219300 to line up the timing holes in the cams with the hole in the punch unit left side frame.
2. Set the punch index at 0°.

### Interposer Setup Bail Adjustments (Figure 44)

1. Remove punch unit from machine.
2. Remove punch magnet unit from punch unit.
3. Remove stripper assembly. NOTE: Mark or scribe a line on both ends and one side of stripper assembly to maintain punch registration when replacing on punch unit.
4. Set the punch unit on a flat surface and place gage (P/N 600914) as close as possible to the right side frame.
5. Turn the punch drive unit cam shaft until the setup bail rests on top of the gage (Figure 44). Make a note of the index setting.
6. Remove the gage without disturbing the setup bail, and insert the gage at the left side of the setup bail. Place the gage as close as possible to the left side frame.
7. The setup bail should rest on top of the gage in the same manner as in Step 2. Check the index setting to insure it has not changed since Step 2. Use the eccentric stud at the left end of the bail to satisfy this condition.
8. Re-check the adjustments after several rotations of the punch drive unit cam shaft.

NOTE: The setup bail height must be gaged as close as possible to the punch drive unit side frame. The side frames must be in contact with the surface on which the gage is resting. Careful adherence to these precautions and to the procedure just outlined will result in a bail parallelism of within .003".

### Interposer Setup Bail Removal

1. Remove the punch unit from machine.
2. Remove the cam follower assembly from the punch drive unit.

3. Loosen the set screws in the collars on the interposer setup bail pivot shaft, and on the interposer setup bail.
4. Remove the interposer setup bail pivot shaft.
5. Remove the front pivot (column 1 end).
6. Remove the interposer setup bail.
7. Assemble in reverse order.

NOTE: Check the interposer setup bail adjustments.

### Punch Magnet Yoke Assembly Adjustments (Figure 49)

1. Remove punch unit from machine.
2. Remove punch magnet unit from punch unit (not always necessary).
3. With magnet yoke assemblies removed from magnet unit check:
  - a. For .002" to .004" clearance between armatures and cores.
  - b. For armature to pivot rod clearance. Set clearance to somewhere between a wink of movement to a maximum of .008" with the operating end of armature held against the yoke.

### Service Checks

With the magnet yoke assembly removed check for:

1. Armatures for wear or for striking core and for loose springs or rivets.
2. Excess grease or contamination between armatures and yokes.
3. Binding between latches and latch guides.

### Punch Magnet Yoke Assembly Removal

1. Remove magnet yoke assemblies 2, 3, and 4 (counting from top to bottom).
2. After inspection of units, replace assembly 4 and then 3.

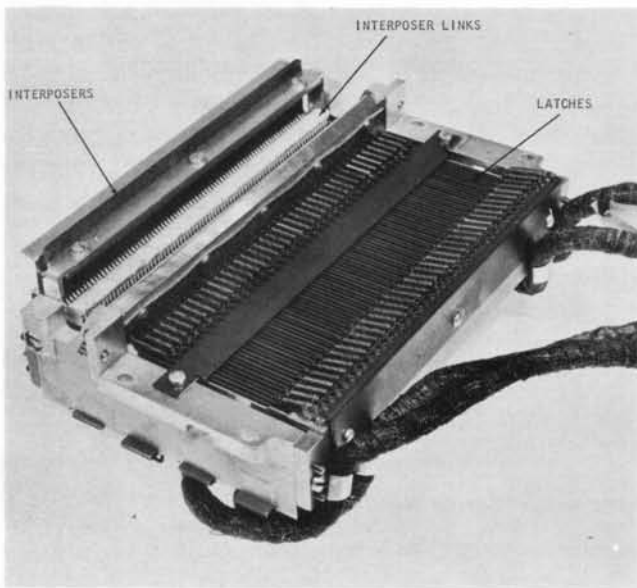

Figure 46. Punch Magnet Unit

3. Remove magnet yoke assembly 1.
4. Replace magnet yoke assembly 2 and then 1.

NOTE: The four magnet yoke assemblies should be installed tight against the upper edge of the slot. Yoke assemblies go in easier with latches in lowest position. Center the yoke assembly so that the nylon armature guide comb does not interfere with the ears on the latches.

### Punch Magnet Unit Adjustments

The following steps will insure armature sealing:

1. Remove punch unit from machine.
2. Turn the punch cam shaft until the interposer setup bail is at its lowest limit of travel.
3. Check for .007" to .013" clearance between the lower side of the armature and the latch at both the column 1 and column 80 ends of the unit (Figure 49).
4. Adjust the two screws which position the magnet unit on the punch unit frame to obtain this clearance (Figure 43).
  - a. Loosen the magnet unit mounting screws.
  - b. Loosen the magnet unit adjusting lock nuts and adjust the screw for .007" to .013" clearance between the armature and the latch (Figure 49). The magnet unit locating screws hold the magnet unit against the adjusting screws.
  - c. With the interposers centered over their respective punches, tighten the mounting screws and re-check the clearance between the armature and its latch.

### Punch Magnet Unit Removal

1. Remove the punch unit.
2. Remove the punch and stripper assemblies.

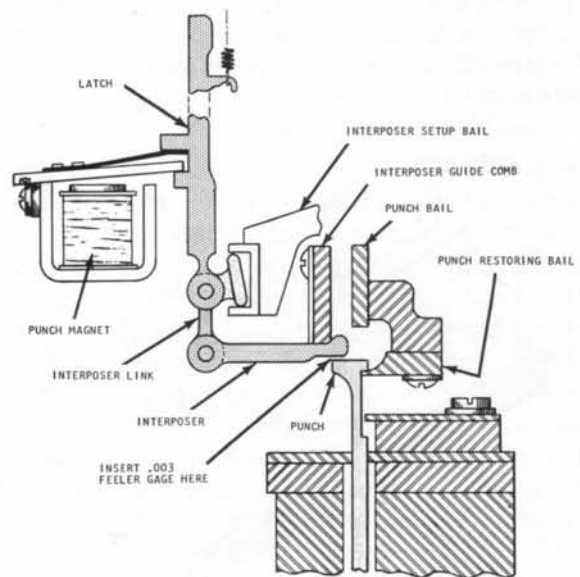

Figure 47. Interposer Guide Comb Adjustment

3. Remove the interposer cover.
4. Loosen the magnet unit locating screws at either end of the punch unit side frame.
5. Remove four mounting screws from the magnet unit. Do not disturb the punch magnet unit adjusting screws (Figure 43).
6. Lift the magnet unit off the punch unit frame.
7. Use a rubber band to keep the interposers from falling out.

### Punch Magnet Unit Installation

1. Place the magnet unit in position on the punch unit frame. Use the edge of the interposer cover to hold the interposers in place.
2. Tighten the magnet unit locating screws which forces the magnet unit against the punch unit side frame.
3. Replace the magnet unit mounting screws.
4. Replace the punch and stripper assembly.
  - a. Check for .007" to .013" latch overthrow (Figure 49).
  - b. Check for .003" interposer to punch clearance (Figure 47).
5. Replace the interposer cover.

### Interposer and Guide Comb Adjustments

1. Remove the punch unit from machine.
2. Check for .003" minimum clearance between the interposers and the interposer guide comb. To check, proceed as follows:
  - a. With the punch magnet de-energized, insert a .003" feeler gage between the punch and interposer (Figure 47).

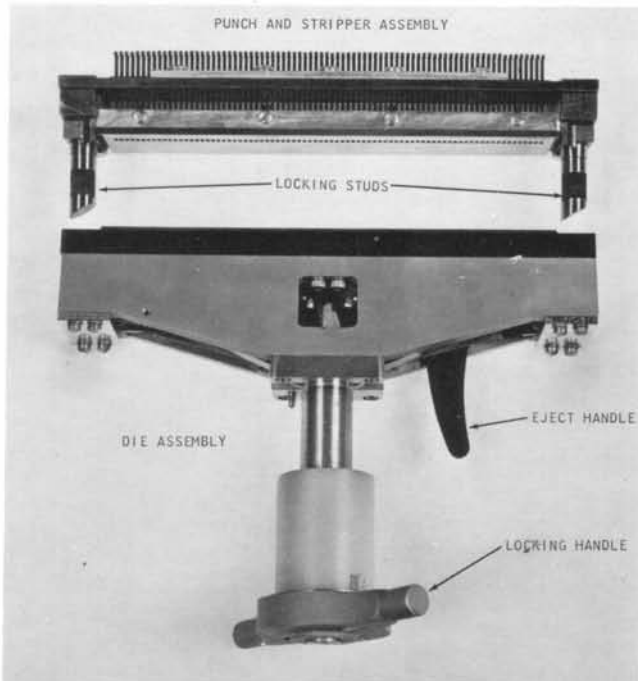

Figure 48. Redesigned Die and Stripper

- b. Rotate the punch cam shaft through a complete revolution making sure no binding condition exists at any point in the punch cam shaft cycle.
3. To adjust the interposer guide comb, proceed as follows:
    - a. Loosen the interposer guide comb clamping screws slightly (Figure 43).
    - b. Loosen the lock nuts on the interposer guide comb adjusting screws.
    - c. Move the interposer guide comb by means of the adjusting screws, until the proper clearance is obtained. (Use a .005" feeler gage inserted between the punch and interposer while adjusting).
    - d. Tighten the lock nuts and the clamping screws.
    - e. Re-check clearance as outlined in Step 2.

NOTE: Lack of clearance between the interposers and the interposer guide comb at any point of the punch cycle can cause breaking of punches.

### Interposer and Interposer Link Removal (Figure 46)

1. Remove the punch unit from machine.
2. Remove the punch magnet unit from the punch drive unit. It is not necessary to remove the yoke assemblies.
3. Remove the latch spring in the position to be removed.
4. Push the latch to its lowest limit of travel. NOTE: If this travel is not sufficient, remove the yoke assembly containing the magnet controlling the position to be removed. This will increase the latch travel.
5. Unhook the interposer link from its latch.
6. Remove the interposer and interposer link.
7. Assemble in reverse order.

### Stripper Assembly Removal (Figure 43)

1. Mark or scribe a line on both ends and on one

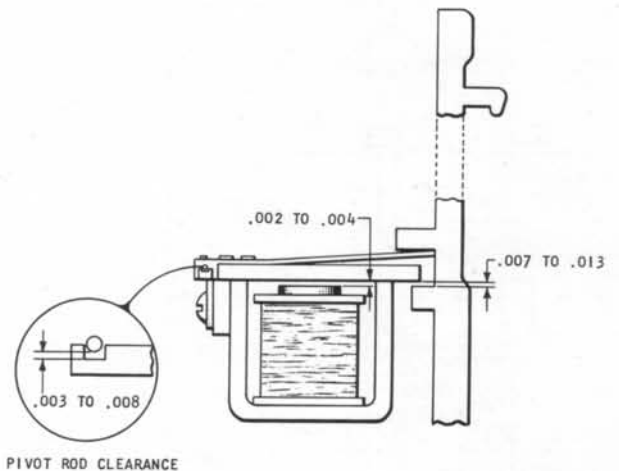

Figure 49. Punch Magnet Adjustments

side of the stripper assembly to maintain punch registration when replacing on the punch unit.

2. Remove four screws and remove from punch unit.

### Stripper Assembly Installation

1. Re-install the stripper assembly in its original position on the punch unit.

2. Check to see that the toes of the punches retract .003" to .006" into stripper. Adjust by adding or removing shims (P/N 437694) between the stripper assembly and the punch drive frame. P/N 437694 is .003" thick.

NOTE: If the toes of the punches are retracted more than .006" within the stripper, the heels of the punches may shear the stripper plate.

3. Be sure the punches are not driven against the punch retaining plate (Figure 50).

4. Adjust the retainer plate for .004" to .007" clearance between the plate and the punches (Figure 50).

### Latch Removal (Figure 43)

1. Remove the punch unit from the machine.  
2. Remove the punch magnet unit from punch drive unit.

3. Remove the magnet yoke assemblies from punch magnet unit.

4. Remove the latch spring from the latch to be removed.

5. Push down the latch spring from the latch to be removed.

6. Push down on the latch and unhook the interposer link.

7. Remove the latch from the magnet side of the unit. The latches next to the one being removed may

have to be moved slightly to obtain sufficient room for removal.

8. Assemble in reverse order using the following hints:

a. Replace the punch magnet unit on the punch drive unit before replacing the magnet yoke assemblies.

b. The latches can be pulled down to the lowest limit of travel to facilitate installation of the magnet yoke assemblies by rotating the cam shaft.

c. Position the magnet mounting bar against the top of the slot in the magnet unit side frame. Be sure that the nylon latch guides do not bind the latches.

### Punch Removal (Figure 43)

1. Remove the punch unit from machine.

2. Remove the punch and stripper assembly.

a. Remove the four mounting screws which hold the punch and stripper assembly to the punch drive frame.

b. Watch for shims which may be between the stripper assembly and the drive frame.

c. Position the punch bail at its lowest limit of travel while separating the punch and stripper assembly from the punch drive frame.

3. Remove the five holding screws and remove the retainer plate from the punch and stripper assembly (Figure 50).

4. Remove the desired punch.

5. Assemble in reverse order.

a. Check for .004" to .007" punch to retainer plate clearance before re-assembling stripper to the drive frame.

b. Check for .003" interposer to punch clearance.

### Punch Unit Vertical Position

NOTE: The following adjustments do not apply to the punch unit using the new redesigned die and stripper. These adjustments position the punch unit vertically for proper die operating clearance with lowering frame up.

1. Remove the four top holding screws for the punch unit (Figure 51).

2. Loosen the four locking nuts and turn the adjusting sleeves as required. Use gage (P/N 610692) to check squareness of punch unit to the top of the machine side frame. Punch unit must be square to the gage within .0015".

3. The adjusting sleeves must also be set so that the die handles exhibit no wink to a very slight wink when the units are cold. Check each handle separately. This will assure that the die lugs are tight when operating temperatures are reached.

4. When raising the lowering frame, contact with the die lugs should be felt on the last 5 to 10 degrees rota-

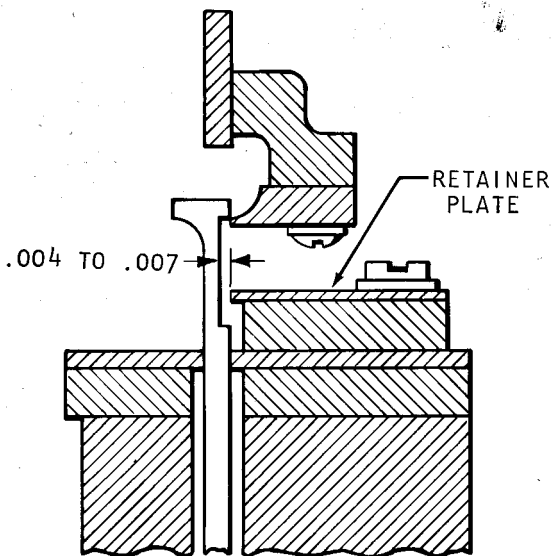

Figure 50. Retainer Plate Adjustment

tion of the lowering frame handle with the machine at operating temperature.

NOTE: If the die latch bars do not have enough drag, the die will vibrate and accelerated punch wear may result.

### **Punching Registration**

1. Run cards through machine and check the punching registration with a card gage.

2. To shift the punching laterally on the card (horizontal registration):

a. Loosen the four holding screws on top of the punch unit (Figure 51).

b. Loosen the locknut on the horizontal adjusting screw and turn the adjusting screw in the proper direction to permit shifting the punch unit in the direction required to correct the horizontal registration (Figure 51).

c. Move the punch unit so that it is tight against all three adjusting screws and tighten the holding screws. Loosen the die or drop the lowering frame if the punch unit is hard to move in obtaining this adjustment.

d. Check the registration. If necessary, repeat Steps a through c.

3. To shift the punching vertically on the card (vertical registration):

NOTE: See step 4 before proceeding.

a. Loosen the four holding screws on top of the punch unit (Figure 51).

b. Loosen the vertical adjusting screw locknuts and turn the adjusting screws in or out as required.

c. Tighten the locking nuts on the adjusting screws.

d. Move the punch unit snug against all three adjusting screws.

e. Tighten the four top holding screws.

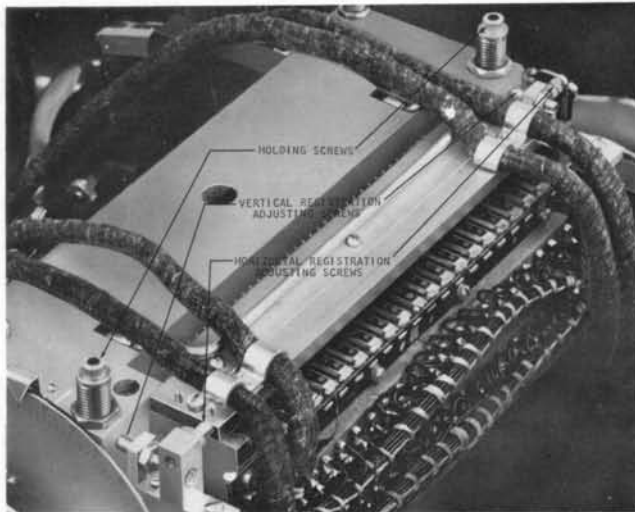

Figure 51. Punch Unit Adjusting Screws

f. Check registration. If necessary, repeat steps a through e.

4. If the vertical registration is off more than a few thousandths of an inch, the punch unit adjustment is not likely to be the cause. Investigate some other possible source of trouble:

- a. Aligner station for correct operation and timing.
- b. Proper card feeding—Loose feed roll belts, etc.
- c. Punch unit not perpendicular to card line.
- d. Worn or loose geneva studs.

### **Punch Unit Timing**

At 0° on the dynamic timer index or with the geneva timing pin seated, the punch index should read 0°, 120°, or 240°. If the punch index does not read 0°, 120° or 240°, proceed as follows:

1. Loosen the split hub of the punch unit input pulley.

2. Depress the geneva timing pin and turn the machine manually until the pin seats in the geneva drive disc.

3. While holding the geneva in this position, grasp the punch unit output pulley and turn the shaft to 0°, 120°, or 240° on the punch unit index. This timing can be observed from the front side of the machine.

4. Tighten the punch input pulley.

5. Crank the machine over and check the punch unit index with the dynamic timer index.

a. At 0° on the dynamic timer index, the punch unit index should read 0°, 120°, or 240°.

b. If the punch unit is set at 0° when the dynamic timer index is 0°, it will take three revolutions of the dynamic timer index for both to be set at 0° again.

### **Punch Unit Removal**

1. Remove the die.
2. Remove brush block assembly.
3. Remove both belts from punch unit shaft.
4. Remove four holding screws from top of unit.
5. Disconnect four multi-terminal connectors.
6. Lift the punch unit from machine.

### **Punch Unit Installation**

1. Place the unit in machine tight against the vertical and horizontal adjusting screws.
2. Replace the four top holding screws.
3. Connect the multi-terminal connectors.
4. Insert the die.
5. Check squareness and vertical position.
6. Install the belts.
7. Time the punch unit to the machine.
8. Time the PACB's to the punch unit index.

## Timing Belts

Removal of any belt, except the motor belt, or loosening any clamped hub will affect the timing of some unit. When replacing any belt, all units must be re-timed. Removal procedures will only be given for belts that require some special attention.

### Main Drive Belt Removal (Figure 26)

1. Loosen geneva input pulley clamped hub. Remove crank stud and interlock. NOTE: The crank stud has a left-hand thread.

2. Turn machine by hand and work the pulley off the shaft. Do not loosen the lower pulley bracket when removing the belt. The lower pulley bracket should be moved to tighten the belt only.

3. When replacing the main drive belt, the clutch, geneva and PCCB units must be timed unless the clutch and timer are held at proper relationship and the belt is meshed between input pulley and tightener pulley.

### Punch Unit Drive Belt Removal

1. Do not remove geneva housing.

2. Loosen tightener and slide belt off upper pulley.

3. Twist the belt and pass it between the geneva pulley and the side frame. Kinking this belt does not damage it. It contains a synthetic tensile member.

## Electrical Contacts

### Permissive Make Relays

#### Principles of Operation (Figure 52)

All wire contact relays in the 1402 are of the permissive-make type. The difference between them and the conventional type is indicated by their names. In the permissive relay, a contact is never forced to make by armature pressure. The armature is always moved out of the way of an open contact and the spring tension of the contact wire is permitted to make the contact. This can be seen in Figure 53. The fact that the armature is not slamming the contact closed, gives a more closely controlled make with less bounce. The 1402 uses four- and six-position, high speed and standard permissive-make relays. All relays have 20 v coils.

#### Contact Replacement

When a machine malfunction is caused by PM relay contacts failing to make, it may not be necessary to re-

### First Stepped Feed Roll Drive Belt Removal

1. Remove the main drive belt.
2. Unlatch the clutch and rotate the shaft slightly.
3. Loosen the tightener and slip the stepped roll belt off the pulley.
4. Pass the belt between the cam follower and the cam. Do not remove anything from the clutch.
5. Install in reverse order.
6. Re-time the clutch, geneva, first stepped feed roll, and PCCB unit.

### Belt Tension

All belts are to be snug, having no detectable belt slack when holding one pulley and attempting to turn the other in an alternating forward and reverse direction. The stacker and transport mechanism belts should be adjusted for a slight slack or looseness.

### Punch Dynamic Timer

#### Adjustments

The timer dial must be centered so that the light will be in alignment with the index lines at 0°, 90°, 180°, and 270° within 1/2°.

1. Turn machine to approximately 0° and seat the geneva timing pin in the lock notch (Figure 35).
2. Move the timer dial to 0°.
3. Repeat steps 1 and 2 for 90°, 180°, and 270°.

place the entire relay. The following procedure should be used to replace individual contact wires and check common contacts for dust or corroded areas.

1. Remove the two relay yoke mounting screws and separate the contact moulding assembly from the yoke assembly. This will expose the contact wires and common contacts. Use care to prevent breakage of coil wires from relay moulding.

2. Using a screw driver, press the contacts free of the locating hole and remove them from the moulding.

3. Inspect the common contact point for dust or corrosion film. If necessary, lightly burnish the point. Do not attempt to clean the common contact if it is pitted or burned. This will result in increased air gap and loss of contact tension.

4. Check new contacts for correct configuration before installing (Figure 54).

5. Install new contact wires one at a time to avoid twisting.



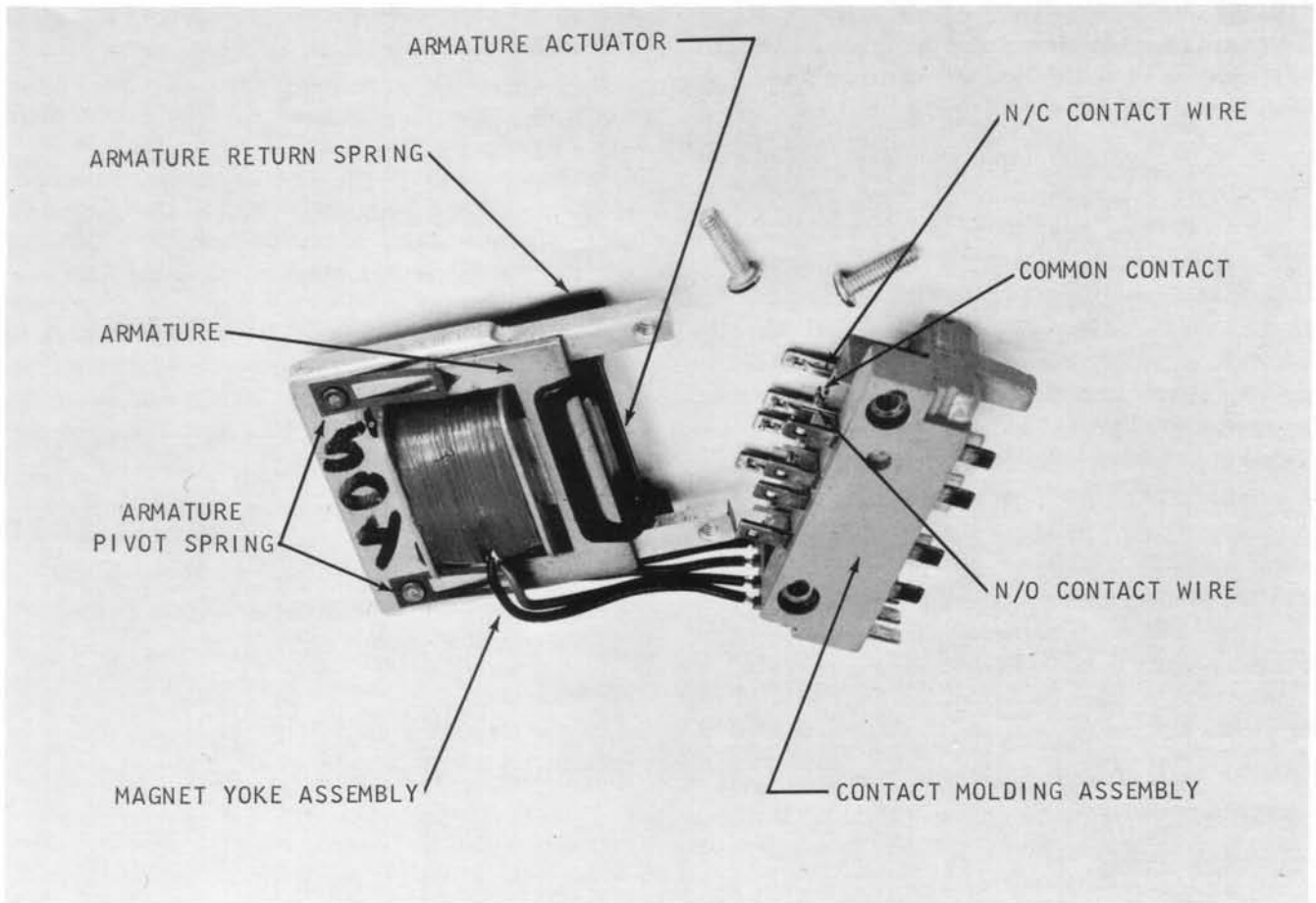

Figure 52. PM Relay

6. Re-assemble yoke to contact moulding assembly. The armature must be centered on the contact wires with equal dimensions between the end contacts and the ears of the moulded armature actuator. Be certain that the yoke is held tight against the mounting pads.

7. Check all wires to see that none are crossed or misplaced from the locating hole. Check for freedom of armature and coil leads and proper seating of the armature pivot springs. Check the operation of the relay contacts with the dynamic timer or oscilloscope.

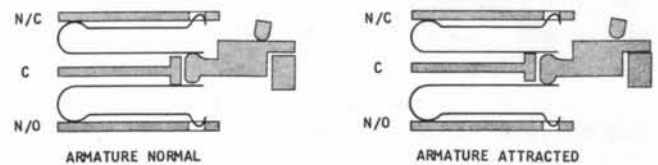

Figure 53. PM Relay Schematic

### Circuit Breakers

The read feed has CB's that are continuously running and some that are under control of the read clutch. Both sets of circuit breakers turn at 800 rpm. The punch feed has three sets of CB's, one set is under control of the punch clutch while the other two sets are continuously running. One set of continuously running CB's turn at 250 rpm while the other set turns at 1333 1/3 rpm. Identification of these circuit breakers is as follows:

- RCCB—Read feed continuously running
- RLCB—Read feed clutch controlled

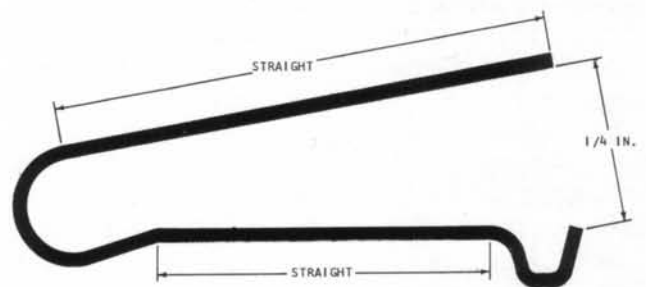

Figure 54. PM Relay Contact Wire

PCCB—Punch feed continuously running  
 PACB—Punch feed continuously running high speed  
 PLCB—Punch feed clutch controlled.

Due to the speed of the 1402 read feed (800 cpm), the digit impulse CB's make and break for alternate cycle points. RL5 and 6 are the make and break for odd digits while RL7 and 9 make and break for the even digits.

In the punch feed, the PACB's are used for digit impulses. They make and break three times for every punch index cycle. Because they are running at 1333 1/3 rpm, they will actually make and break sixteen times every punch machine cycle.

The RCCB's, RLCB's, and PLCB's are the plunger type CB, P/N 602083. The PACB's are the plunger type P/N 228110. If either point becomes burned on these assemblies, replace the entire assembly. The PLCB's are the unitized rocker type, P/N 255970. These cams have removable stationary points. However, if the moveable point becomes burned, the entire contact assembly must be replaced. Stoning or cleaning of any of these cam contact surfaces is not practical as the results do not justify the time and expense involved.

## Service Aids

### Customer Engineering Service Panel

The 1402 Card Read-Punch contains a customer engineer service panel (Figure 55). This panel allows the Customer Engineer to check certain routine areas without going directly to the internal parts of the machine. This can save much valuable time. Following is a list of switches and their use.

**Dial Display Switch:** This toggle switch selects which one of the timer indexes is being used with the service panel.

**Off Line Card Feed:** This rotary switch when set to OFF LINE allows the feeds to be operated independently of the system. It must be set to ON LINE for the system to operate.

**Read Clutch Trip:** This momentary contact switch allows the read clutch to be electrically tripped. The Off Line Card Feed Switch must be on OFF LINE to make this switch effective.

**Brush Selection:** This rotary switch, when set to a brush position, internally connects brush 3 (outer light) and 78 (inner light) of the selected set of brushes to the dynamic timer. When the corresponding feed brush display switch is held on, the brush timing is displayed on the associated feed timer index. Example: To check second read brush timing, set Brush Selection to SECOND

### Timing

The PACB unit can be timed as follows:

1. At 0° on the punch unit index, the mark on the PACB unit side frame and the mark on the CB shaft collar should coincide.

2. If the marks do not coincide, loosen the output pulley of the punch unit and turn the CB shaft until the marks do coincide with the index at 0°. Refer to the wiring diagram for adjustments and the timing of other CB units.

### Open Strap Contacts

#### Adjustments

1. Position all card lever contacts to give a minimum contact travel of 1/16" when the card lever is being operated.

2. Adjust all contacts for 1/32" minimum air gap.

3. All contacts should have a minimum of 1/64" rise of the N/O contact strap off its support.

#### Timing

Refer to the wiring diagram for timing of card lever contacts. These timings *must* be made dynamically.

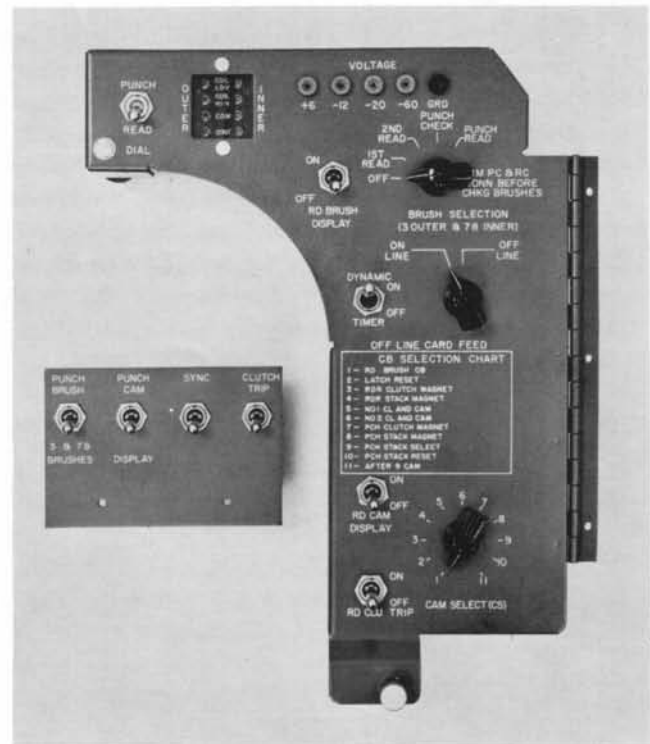

Figure 55. CE Service Panels

READ and run cards through the read feed with columns 3 and 78 punched. When the Read Brush Display switch is held ON, the brush timing is displayed on the read feed index.

**Read Brush Display:** This momentary contact switch is used in conjunction with the Brush Selection switch to display read feed brush timing.

**Cam Selection:** This rotary switch when set to a position on the dial, selects a certain CB for a timing check.

**Read Cam Display:** This momentary contact switch is used in conjunction with Cam Select Switch. It displays the read feed CB selected for a timing check on the read feed index.

**Voltage Hubs:** Each power supply voltage may be

## 1402 Circuits

### Power Supply and Interlock Circuits

The 1402 Card Read-Punch is connected to a 3-phase 208 or 230 v AC source of voltage.

It contains a  $-20$  v supply which is used for read-punch relay and magnet operation. This  $-20$  v is also distributed to the 1401 processor. A ferro-resonant bulk supply distributes 133 v AC to the 1401 processor. A  $-60$  v supply is distributed to the 1401 for use in printer circuits. Besides these supplies, there is a 115 v transformer which furnishes 115 v AC to the blower motors and convenience outlets for the entire system. A  $\pm 3$  v supply used for marginal checking is also located in the 1402 although it is used for marginal checking in the 1401 processor. The controls for the  $\pm 3$  v supply are located in the 1401 processor.

SMS cards control the  $-20$  v and  $\pm 3$  v supplies. The detailed operation of these power supplies is covered in the CE Manual of Instruction of SMS Power Supplies, Form 225-6478. For general information such as voltage rating, etc., refer to *Power Supply* in the 1401 Manual.

The source voltage is applied to the 115 v transformer through a set of HD8 relay points (Section 1B 1402 Wiring Diagram). HD8 (Section 1A) is energized any time the machine is connected to the source voltage. HD8 is de-energized only when the emergency stop switch is open (located on the 1401 console). This will drop all voltages, including the 115 v at the convenience outlets by de-energizing the contactor and HD8.

The source voltage is applied to all other units of the 1402 through a contactor. This contactor (Section 1A) is energized by a POWER-ON switch, located on the 1401 console. When the contactor is closed, power is supplied to the  $-20$  v supply,  $-60$  v supply, 133 v AC supply, 208 v AC to 1401, and 115 v AC to the blower motors.

checked at these hubs.

**Punch Clutch Trip:** This momentary contact switch allows the punch clutch to be electrically tripped. The Off Line Card Feed switch must be set to OFF LINE to make this switch effective.

**Sync:** Because the punch feed has a four-tooth clutch ratchet, this momentary contact switch is used to sync the punch feed and the punch index at  $315^\circ$ .

**Punch Brush Display:** This momentary contact switch is used to display the timing of the punch check brushes when the Brush Selection switch is set to the PUNCH CHECK position.

**Punch Cam Display:** This momentary contact switch is used in conjunction with the Cam Selection switch to display the punch feed CB selected for a timing check.

HD4 (Section 2B) is picked from the processor after proper power-on sequence has been completed. (The power on and off sequence are explained later). HD4 furnishes a hold for the power contactor (Section 1A) after the POWER-ON key is released.

The POWER-OFF switch, when operated, will de-energize HD4. The contactor has now lost its hold circuit and will now de-energize.

### Power On Sequence

1. (1A) The POWER ON key energizes the contactor.
2. (1A) The contactor points furnish power to the  $-20$  v and  $-60$  v supplies in the 1402. They also furnish power to the  $+30$  v,  $+6$  v and  $-12$  v supplies in the 1401.
3. HD12 in the 1401 picks when the  $+6$  v and  $+30$  v are available and supplies the rest of the relays with  $-20$  v (HD15 also picks with HD12 if required).
4. (2B) HD3 picks when the  $-12$  v is available. HD10 and HD11 in the 1401 also pick at this time (HD14 also picks with HD3 if required).
5. The  $-6$  v,  $-20$  v, and  $+30$  v circuits are now available in the 1401.
6. With the  $-6$  v circuits available, DU11 picks in the 1401 (HD13 also picks with DU11 if required).
7. The  $-36$  v circuit is now available in the 1401 if required.
8. With the  $-36$  v circuit available, DU12 picks in the 1401 if required.
9. (2B) HD4 and HD9 can now pick.
10. (1A) HD4 keeps the contactor energized after the POWER ON key is released. HD 9 completes the  $-60$  v sequenced circuits.

The complete Power On sequence takes from .5 to .7 seconds. This time is hardly noticeable from the operator console.

## Power Off Sequence

1. (2B) Pressing the POWER OFF key drops HD4 and HD9.

2. HD9 removes the -60 v sequenced from the 1401 circuitry immediately.

3. (1A) HD4 opens the hold circuit to the contactor.

4. Opening the contactor de-energizes the dc power supplies simultaneously.

The Power Off Sequence takes from .2 to .5 seconds. The power on and off sequences are needed in order to energize the 1403 Space (Off) and Skip (Off) magnets before carriage and chain motors start running. Otherwise the 1403 could start out in a skip or continuous space operation.

## Read Feed Circuits

### Load Key Operation

The LOAD key causes the 1402 read feed to take three run-in card-feed cycles under program control. The LOAD key sets up a read instruction in the 1401 processor which will enable the read feed to run until a card has passed the read brushes.

1. (4B) R8 (delay) hold coil will be energized through R1-3N, R9-2N and the interlock switches.

2. (5B) The LOAD key (No. 2) will pick DU2, the start relay.

3. (4B) DU2-AU will pick R9 through the reader switch ON and the interlock switches. R9 will hold through its own 1 point.

4. (4B) R9-2N opens the circuit to R8. R8 will now hold through its delay circuit (3K resistor and 7500 mfd capacitor). Adjust for 7 to 10 seconds delay.

5. (4B) R9-2T will pick HD1 (read motor control). HD1 will supply AC voltage to the read-feed drive motor.

6. (4A) With file feed now operating, cards enter the hopper and pick R1.

7. (4B) As soon as R8 drops, R7 picks through R9-3T, R8-1N, and RC3.

### FIRST CARD-FEED CYCLE

1. (6A) The -T PROCESS FEED line will be conditioned by RC5, R7-2T, R6-3N, and R4-2N. The -T PROCESS FEED line in conjunction with the read instruction set up in the 1401 processor by the LOAD key, activates the -T READ CLUTCH line (6A). The -T READ CLUTCH line will energize the read clutch magnet and R10, the clutch check relay, through RC5.

2. (4A) R2, the No. 1 card-lever relay, will pick and hold on this card-feed cycle.

3. (4A) R6 will pick and hold on this card-feed cycle and all further read-feed cycles.

### SECOND CARD-FEED CYCLE

1. (6A) The -T PROCESS FEED line will be conditioned through RC5, R7-2T, R6-3T, R2-3T, and R1-6T.

2. (6A) The read-feed clutch and R10 will be energized the same as on the previous card-feed cycle.

3. (4A) R3, the No. 2 card lever relay will pick and hold on this card-feed cycle.

### THIRD CARD-FEED CYCLE

A third card-feed cycle will be obtained the same as the previous card-feed cycle. After the third card-feed cycle, the 1401 processor will start processing information just read from the card at the read brushes. All further card-feed cycles will be under program control.

### Start Key Operation

The START key (No. 1) in section 5A will allow the read-feed motor to start, as described under *Load Key Operation*. No card-feed clutch operations are taken until a program instruction calls for one. Any card-feed clutch cycles that are taken use the same circuits described under *Load Key Operation*.

### Card Reading

The first and second read brushes (7A and 8A) provide card digit impulses to the 1401. Each brush station consists of 80 brushes and is capable of reading any digit in the card.

1. The base of T2 will be conditioned for every impulse by R3-5T, RL5 and 6 (odd) or RL7 and 8 (even), and R7-3T.

2. When T2 conducts, ground potential is applied to the common brush. T2 conducting also applies 1/2 write current through all 80 row bit cores.

3. When a hole in the card is read a circuit exists from T2 conducting (0 volts), common brush, contact roll, read brush, and the respective row bit core to -20 v. This furnishes the other 1/2 write current to the proper core (refer to 1401 manual).

### Reader Non-Process Run-Out

The NPRO key is used to clear the read feed of cards that are not to be processed. The hopper must be empty before this key is effective.

OBJECTIVE: Start a feed cycle by using the NPRO key.

1. (4B) The read NPRO key (No. 1) will pick R9 through R1-1N, the reader switch ON, and the interlock contacts.

2. (4B) With R9 energized, the HD read motor relay is energized and the read motor started.

3. (5A) The read NPRO key (No. 2) picks R4 and turns on the READER STOP light.

4. (4B) R9-3T and RC3 picks R7.

5. (5A) The —T NOT PROCESS FEED line is conditioned through R4-2T, R6-3N, R7-2T, and RC5.

6. (5A) The —T NOT PROCESS FEED line can also be conditioned through R6-3T, R2-3N, R1-6N, and R3-4N.

7. When the NPRO key is used, the last two cards in the NR stacker have not been processed. The CHECK RESET key must be used to drop out R4 (Refer to *Card Jam Circuits*, Steps 8-11).

### Stop Key Operation

OBJECTIVE: Allow the read feed to stop when the STOP key is depressed. This will also stop the complete system.

1. (3B) The STOP key (No. 1) will open the circuit to the motor control relay (R9) causing the read-feed drive motor to stop.

2. (6B) STOP key (No. 2) will activate the —T STOP KEY line at RC179.

3. The —T STOP KEY line will condition circuitry in the 1401 which will pick DU3 (6A).

4. (3B) DU3-AU keeps the circuit to R9 open after the STOP key is released.

5. The START key is used to re-start the read feed. The START key will cause DU3 to drop out through the use of the +U INTERLOCK STOP line (6A).

### Card Jam Circuits

A card jam is detected when the number one or number two card-lever contact remains closed too long during a read-feed cycle.

OBJECTIVE: Stop the read feed if a card jam is detected and turn on the READER STOP light.

1. (3A) If either card lever (1 or 2) remains closed until 158° of a read cycle, the read stop relay (R4) is picked.

2. (4A) R4 picks through RC7, diodes (RD56 or 57), card lever contacts, and RL1.

3. (5A) R4 will hold through R4-1T and R2-4T or R3-3T to ground. After all card levers have returned to normal, R4 will hold through DU4-AU. The READER STOP light also is on in parallel with R4 hold.

4. (4B) R4-5N opens the circuit to R9, causing the read drive motor to stop.

5. (5B) R4-6T activates the —T READ JAM line, which is used in the 1401.

6. (6A) The R4-2T point allows the cards remaining in the feed to be run out under control of the NPRO key by activating the —T NOT PROCESS FEED line.

7. (7A) R4-4N opens the —T BRUSH IMPULSE CB line to the 1401.

8. The CHECK RESET key must be used to drop out R4 and allow the read feed to be re-started.

9. (6B) The CHECK RESET key picks DU4 through R28-3T and R7-3N to —20 v.

10. (6A) The DU4-AU point opens the hold circuit to R4 and turns off the READER STOP light.

11. (5A) The DU4-BU activates the +U READ CHECK RESET line to the 1401.

### Clutch Check Circuit

Each time the read clutch magnet is energized, R10 is also energized. If the read feed clutch magnet receives an impulse and fails to pick, or a clutch cycle is taken without the clutch receiving an impulse, R10 signals a clutch failure.

OBJECTIVE: Stop the read feed drive motor and turn on the READER STOP light under the following conditions:

1. When the clutch receives an impulse and fails to unlatch.

a. (5A) R10 is picked by read clutch impulse from the 1401. R10 holds through R10-1T and RC4 (4A).

b. (4A) R4 picks through RC7, R10-2T, and R6-4N. With R4 energized, the read feed will stop as described under *Card Jam*.

2. When the clutch unlatches without receiving an impulse.

a. (4A) R6 picks through RL3 because of a card feed cycle.

b. (4A) R4 picks through RC7, R10-2N, and R6-4T. With R4 energized, the read feed will stop as described under *Card Jam*.

### Punch Feed Circuits

#### Punch Feed Run-In

When the LOAD or START key is depressed, the punch feed will take one card-feed cycle. After that cycle, all remaining card feed cycles are under program control.

OBJECTIVE: Cause a card-feed cycle when the LOAD or START key is depressed. Punch switch must be ON.

1. (10B) R28 (Run Delay) is picked whenever the punch motor stops.

2. (10A) Cards in the hopper will pick R21.

3. (6A) DU2 is picked by the LOAD or START key.

4. (10B) R29 and HD2 are picked through interlock contacts, DU2-BU, R31-2N, DU3-BU, chip switches and punch switch ON. With these two relays picked, the punch feed motor will start.

5. (10B) R29-2N point drops R28.

6. (10B) R27 (Run) is picked by R29-3T, PC1, 21-4T and same circuit that picked R29 and HD2. R27 holds through R27-1T and PC2.

#### First Card Feed Cycle

1. (12A) The —T PROCESS PUNCH line is conditioned by R31-3N, R27-4T, PC4, PC3, and PL6. This line will activate circuitry in the 1401 which will condition

the —T PUNCH CLUTCH MAGNET line (12A) and causes the punch to take a feed cycle.

2. (10A) R22 is picked as the throat card lever makes on this cycle. R22 holds through PL2.

3. All further card-feed cycles will be under program control.

### **Punch Feed Read**

This optional feature allows cards to be read in the punch feed one cycle before punching rather than from the read feed brushes.

OBJECTIVE: Allow cards to be read at the punch feed read station.

1. (13A-B) R59 is picked by an instruction from 1401. R59 holds through R59-3T. PL17 and R46 through R58 pick in parallel with R59 hold.

2. (14A-B) The punch read brushes will now set the row bit cores by R59-5T and R59-6T in parallel whenever T1 conducts.

3. (13A-B) The base of T1 is conditioned by R59-4T, R25-2T, R31-5N, PA10, PA9, and PL10.

### **Card Punching**

Any punch magnet can be energized when PA5, 6, 7, and 8 make and its respective +U PUNCH MAGNET line is activated from the 1401.

### **Punch Check Brushes**

The punch check brushes are used to read the card after it has been punched. Circuits for the 80 brushes are similar to the circuits covered for the read feed brushes.

### **Punch Non-Process Run-Out**

The NPRO key is used to clear the punch feed of cards. Cards must be removed from the punch hopper before this key is effective.

OBJECTIVE: Start a punch feed cycle by using the NPRO key.

1. (9B) The punch NPRO key (No. 1) will pick R29 and HD2 through the interlock contacts, R21-1N, chip switches, and the punch switch. The punch feed motor will start with the above relays energized.

2. (11A) The punch NPRO (No. 2) picks R31 hold coil through R27-2N and turns on the PUNCH STOP light.

3. (10B) R27 is picked as normal.

4. (12A) —T NOT PROCESS PUNCH line is conditioned by R31-3T, R27-4T, PC4, PC3, and PL6. The 1401 will then condition the —T PUNCH CLUTCH MAGNET line and energize the punch clutch.

5. The CHECK RESET key must be used to drop out R31 (Refer to *Card Jam*, Steps 5-7).

### **Stop Key Operation**

OBJECTIVE: Allow the punch feed to stop when the STOP key is pressed.

1. (3B) The STOP key (No. 1) will open the circuit to R29 and HD2 (10B), causing the punch feed motor to stop.

2. (6B) DU3 will be picked the same as described under *Read Stop Key Operation*.

3. (9B) DU3-BU will keep the circuit to R29 and HD2 open after the STOP key has been released.

4. (5A) The START key will drop out DU3 through the use of the +U INTERLOCK STOP line from the 1401 (6A).

### **Card Jam Circuits**

A card jam or misfeed is detected by the card lever relay points (11A). When a feeding failure is detected, the punch feed will be stopped.

OBJECTIVE: Stop the punch feed if a jam or misfeed is detected.

1. (12A) R31, the punch stop relay is picked through the card lever relay points and PL7. The —T PUNCH JAM line is conditioned at the same time. If any delay relay picks when they should not, or any card lever relay fails to pick, then a circuit is available at PL7 time.

2. (11A) R31 will hold through R31-1T and the card lever relay points to ground. It can also hold through DU4-BL to ground. The PUNCH STOP light is turned on in parallel with R31 hold.

3. (9B) R31-2N opens the circuit to R29 and HD2. The punch feed drive motor will stop.

4. The cards must be run out of the feed by use of the NPRO key and then the CHECK RESET key must be used to restore the punch feed to an operating status.

5. (5B) The CHECK RESET key will pick DU4 through R28-3T and R7-3N.

6. (11A) The DU4-BL point opens the hold to R31 and turns off the PUNCH STOP light.

7. (11A) The DU4-AL point conditions the +U READ CHECK RESET line to the 1401.

### **Clutch Check Circuit**

Each time the punch clutch magnet is energized, R30 is also energized. If the punch feed clutch magnet receives an impulse and fails to pick, or a clutch cycle is taken without the clutch receiving an impulse, R30 signals a clutch failure.

OBJECTIVE: Stop the punch feed drive motor.

1. When the clutch receives an impulse and fails to unlatch.

a. (12A) R30 is picked by the —T PUNCH CLUTCH MAGNET line from the 1401 and the CB's.

b. (10B) R10 holds through PL4.

c. (12A) R31 is picked by R30-4T, PC5, and PL6.

d. (9B) R31-2N opens the motor relay circuit, stopping the punch feed motor. The cards must be removed from the feed and the CHECK RESET key pressed to restore the punch feed to an operating status.

2. When the clutch unlatches without receiving an impulse.

a. (12A) R30 will not pick.

b. (12A) R31 is picked through R30-2N and PL7. This circuit also conditions the —T PUNCH JAM line which will stop the punch feed through the 1401 circuitry.

c. (9B) R31-2N opens the motor relay circuit, stopping the punch feed motor. Remove cards from the hopper and press CHECK RESET key to restore punch feed to operating status.

### **Stacker Select Circuits**

1. (11B) The stacker card lever picks R37 anytime a card enters the transport unit from the punch feed.

2. (12B) R35 will pick on every punch-feed cycle between times that the stacker card lever is made through R37-3N and PL15.

3. (12B) R35 pick coil has a hold after R37 picks through R35-2T, R37-3T, R35-1T, PC6, and stacker card lever.

4. (11B) R35 hold coil can energize if the +U STACKER INHIBIT line becomes active.

5. (11B) The stacker control relays are picked by the +U STACKER 4 or 8 from the 1401. R33 or 34 will then hold through PL14.

6. (12B) The stacker 4 magnet is picked through R33-2T after R35 has dropped and the stacker card lever has closed by PC6 time at 35° to 75°.

7. (12B) R31 will pick through R37-2N and R32-4T if a card was at the punch check brushes but did not reach the stackers on the next punch-feed cycle.

8. (12A) R31 will pick through R35-4N and 32-4T if a punch cycle is taken after a card has been at the punch check brushes and stacker inhibit (R35) fails to pick.

1402 PREVENTIVE MAINTENANCE ROUTINE

CODE	UNIT	FREQ.	LUBRICATE—CLEAN	OBSERVE
4	Punch Unit	4	Felt wicks for punches .....#9 Four punch bail cam followers .....#20	Cam followers for wear and proper adjustment.
4	Punch Transport	13	Clean card feed path. Contact and feed roll hange pivots, stacker pusher pivots, latch cam follower and clutch pivots, etc. ....#9, Gears, aligner cams roll opening and offset cams, punch clutch latch cam, extension spring ends, and stacker jogger cams .....#17	Brushes for wear and damage. Brush timing. Punch registration.
4	Punch Unit	13	Felt wicks for latches .....#9 Latch spring hooks .....#17 Punch cam follower pivots and bearing links (4 grease fittings) .....#20	Check for excess internal backlash in the geneva mechanism on at least two intermittent motion cycles. Check throughout the movement portion by holding input pulley and rocking intermittent rolls back and forth.
1	Read Clutch		Armature, latch and keeper pivots, load and detent pawls pivot .....#6 Clutch intermediate arm pivot .....#9 Continuously running clutch drive wheel, clutch needle bearing grease fitting, keeper and latch working surfaces .....#17 Reverse lock grease fitting .....#20	Detent, pawl, and keeper for wear. Excess clutch backlash while engaged. Check clutch drive wheel rubber mount for looseness.
0	Filter	17		Replace if dirt is visible from inside.
1	Read Feed		Ball bearing hanger and all other pivots .....#6 Clean card feed path All gears, P.K. cams, spring ends .....#17 Stacker jogger clutch spring .....#20	Check brush wear and timing. (Use C E Service Panel).
1	File Feed	17	Cam follower arm, front and side jogger pivots .....#9 All other pivots and shaft pivots .....#6 Front jogger extension spring ends, gears, jogger cams, adjusting screw surfaces, clutch latch cam surface, side jogger flat return spring .....#17 Clutch grease fitting .....#20	Check clutch overthrow. Check condition of belts. Check feed rolls for glaze.
3	CB's		CB arm pivots and CB rollers .....#9 CB cams and drive gears (Non-Nylon only) .....#17 (Nylon are greased initially only)	Check contact condition and movement. Timing of CB's connected to C E Service Panel.
4	Punch Clutch	26	Latch cam follower, all other clutch pivots and dog stud .....#9 Latch cam and armature at latch pivot .....#17	
5	Drive		Fill geneva housing to line and drive motor oil cups .....#9 Geneva gears .....#17	Check geneva gears for wear and for loose pins. Checks belts for wear and tightness. Pulleys for alignment.
0	Base	52	Lubricate cover latches and operating surfaces .....#17	
5	Drive		Change geneva oil .....#9	