

# IBM<sup>®</sup>

## Customer Engineering Manual of Instruction

NOTE: This edition, Form 22-6284-1, is written for the Stage 4 IBM 650 Data-Processing System. This does not obsolete Form 22-6284-0 (Text) and Form 22-6213-1 (Illustrations).

ISSUED TO:

**JOLO FALK**

BRANCH OFFICE:

**SANTA MONICA**

DEPARTMENT:

ADDRESS:

If this manual is mislaid, please  
return it to the above address.

**650 @ M.G.M.**

# 650

## Data-Processing System

© 1956 and 1957 by  
International Business Machines Corporation  
590 Madison Avenue, New York 22, N. Y.  
Printed in U. S. A.  
Form 22-6284-1

# CONTENTS

## SECTION I. GENERAL PRINCIPLES

General Features .....	I-1
Number Systems for Digit Representation .....	I-2
Drum Arrangement and Timings .....	I-3
Stored Programming .....	I-10
Logical Organization, Data Flow, and Program Control .....	I-11
Summary of Various Data Flow Paths .....	I-16
Physical Organization .....	I-16
Current Requirements, Dimensions, Weight, and Heat-Dissipation Data .....	I-17
Self-Checking .....	I-17

## SECTION II. BASIC PRINCIPLES

PROGRAMMING .....	II-1
Storage Address and Operation Codes .....	II-1
Summary of Operation Codes .....	II-1
Examples of Programming .....	II-2
Loading .....	II-3
BASIC ELECTRONIC CIRCUITS .....	II-8
Inverters and Double Inverters .....	II-8
Cathode Followers .....	II-9
Germanium Crystal Diode Switch and Mix Circuits .....	II-10
Diodes Used for Restoration of DC Levels .....	II-12
Vacuum Diode Switching Circuits .....	II-14
Latch Circuits .....	II-15
Latch Ring .....	II-17
Voltage Amplifiers .....	II-18
Shaping Amplifiers .....	II-18
Power Units .....	II-20
Single-Shot Multivibrators .....	II-22
Vacuum Diodes .....	II-23
Capacitor Storage .....	II-24
GERMANIUM CRYSTAL DIODES .....	II-25
PLUGGABLE UNITS .....	II-26
BLOCK SYMBOLS .....	II-27
Block Symbol Voltage Codes .....	II-27
TIMING PULSES AND GATES .....	II-28
Basic Recorded Pulses .....	II-28
GLOSSARY OF 650 TIMING DESIGNATIONS .....	II-30
Timing Designations .....	II-30
Timing Designations with Abbreviations .....	II-31
Special Pulses .....	II-32
Timing Gates .....	II-33
PRINCIPLES OF MAGNETIC-DRUM STORAGE .....	II-36
Drum Mechanical Features .....	II-47
Heads for Reading and Writing .....	II-48
Reading and Writing Principles .....	II-49
MULTIPLE-WRITE—NO-WRITE CIRCUIT .....	II-56
Multiple Write .....	II-56
No-Write Circuit .....	II-57
SEVEN-TO-FIVE AND FIVE-TO-SEVEN TRANSLATOR CIRCUITS .....	II-58
Seven-to-Five Circuits .....	II-58
Five-to-Seven Circuits .....	II-58
SELECTED STORAGE SWITCHING .....	II-58
VALIDITY CHECK CIRCUITS .....	II-59
Capacitor Storage Validity Check Circuits .....	II-59
Buffer Storage Validity Check Circuits .....	II-60

## SECTION III. 650 CONSOLE UNIT

PROGRAM CONTROL UNITS .....	III-1
The Program Register .....	III-1
Operation and Address Registers .....	III-2
Dynamic Selection Circuits .....	III-5

CONTROL CONSOLE KEYS .....	III-7
Error-Sense Reset Key .....	III-7
Error-Reset Key .....	III-7
Accumulator Reset Key .....	III-7
Program Reset Key .....	III-7
Transfer Key .....	III-8
Program Start Key .....	III-8
Program Stop Key .....	III-8
Computer Reset Key .....	III-8
CONTROL CONSOLE LIGHTS .....	III-8
Checking Lights .....	III-8
Operating Lights .....	III-8
CONTROL CONSOLE SWITCHES .....	III-12
Address Selection Switches .....	III-12
Control Switch .....	III-12
Master Power Off Switch .....	III-12
Half-Cycle Switch .....	III-13
Programmed Stop Switch .....	III-13
Error Stop-Sense Switch .....	III-13
Error Disable Switch .....	III-14
Overflow Stop-Sense Switch .....	III-14
Display Switch .....	III-14
Storage Entry Switches .....	III-15

## SECTION IV. ARITHMETIC UNITS

CAPACITOR STORAGE UNITS .....	IV-1
Distributor .....	IV-1
Accumulator .....	IV-3
ADDER .....	IV-4
Bi-Quinary Arithmetic .....	IV-4
Adder A and B Entry Switching .....	IV-6
Adder Circuits .....	IV-6

## SECTION V. FUNCTIONS OF OPERATION CODES

10's AND 60's CODES .....	V-1
Control Commutator .....	V-1
I HALF CYCLE .....	V-1
Restart A .....	V-3
Restart B .....	V-3
Enable Read-In .....	V-3
Start Read-In .....	V-3
Read-In Program Step .....	V-3
Circuit Description of the Alternation Control Latches .....	V-3
D HALF CYCLE 10's AND 60's CODES .....	V-3
Code 69 .....	V-6
ADDITION AND SUBTRACTION OPERATIONS .....	V-9
Code 10 AU .....	V-9
Code 60 Reset and Add Upper .....	V-9
Code 11 SU .....	V-11
Accumulator Sign Read-Out .....	V-11
Complement Result Operation .....	V-12
NO OPERATION, STOP AND STORE CODES .....	V-15
No Op and Stop Codes 00 and 01 .....	V-15
Store Codes (20's) .....	V-18
SHIFT CODES (30, 31, 35 AND 36) .....	V-20
Code 30 SRT .....	V-20
Code 31 SRD .....	V-21
Code 35 SLT .....	V-29
Code 36 SCT .....	V-29
BRANCH OPERATIONS (40's AND 90's CODES) .....	V-31
Code 44 .....	V-31
Code 45 .....	V-33
Code 46 .....	V-35
Code 47 .....	V-35
Test Codes (90's) .....	V-35

CONTENTS (continued)

MULTIPLICATION (CODE 19) .....	V-36
Functions, Objectives and Circuits .....	V-36
DIVISION (CODE 14) .....	V-42
Principles of Division .....	V-42
TABLE LOOKUP .....	V-53
Table Lookup Check Circuit .....	V-57

**SECTION VI. MANUAL OF OPERATION**

MANUAL READ-OUT STORAGE OPERATION .....	VI-1
MANUAL READ-IN STORAGE OPERATION .....	VI-1

**SECTION VII. INPUT AND OUTPUT CODES**

CONVERSION CIRCUITS FOR READ-IN AND PUNCH OUT .....	VII-1
Read-In from Card (Code 70) .....	VII-1
Code 70 .....	VII-4
Code 71—Punch Out to Card .....	VII-6
SIGN READ-IN AND PUNCH-OUT .....	VII-11
Sign Read-In .....	VII-11
Word Size Emitter .....	VII-13

**SECTION VIII. ALPHABETIC DEVICE**

Alphamerical Input .....	VIII-2
Alphamerical Output .....	VIII-6

**SECTION IX. MAIN POWER SUPPLY**

INTRODUCTION TO THE ACME SINGLE- AND THREE- PHASE POWER SUPPLY .....	IX-1
Application .....	IX-1
Regulator .....	IX-1
Metering .....	IX-2
Servicing .....	IX-3
INTERLOCKING .....	IX-3
Power-On Interlocking .....	IX-3
Power-Off Sequence .....	IX-3

DC-Off Sequence .....	IX-5
DC-On Sequence .....	IX-5
Master Power-Off Switch .....	IX-5
DESCRIPTION AND PURPOSE OF COMPONENTS .....	IX-6
Contactors—115 Volts AC .....	IX-6
Relays—42 Volts DC .....	IX-6
Timers .....	IX-7

**SECTION X. 533 MECHANICAL PRINCIPLES  
AND CIRCUITS**

Punch Drive Mechanism .....	X-1
Read Drive Mechanism .....	X-3
CONTROL PANEL .....	X-3
533 CIRCUITS .....	X-3
DOUBLE PUNCH, BLANK-COLUMN DETECTION .....	X-3
Double Punch Detection Circuit .....	X-3
Blank Column Detection Circuit .....	X-5
Double Punch Detection Exit .....	X-5
PUNCH DELAY .....	X-5
Punch Delay Application .....	X-5
Punch Delay Circuit .....	X-5
CONTROL INFORMATION .....	X-5
Control Information Application .....	X-6
Circuit Description .....	X-6
READ CODE SELECTOR .....	X-7
Read Code Selector Application .....	X-7
Circuit Description .....	X-7
RSO (Read Second Only) Wired .....	X-7
READ FEED CIRCUITS .....	X-8
PUNCH FEED CIRCUITS .....	X-8
CARD FEED STOP .....	X-12
Circuit Operation .....	X-12
END OF FILE .....	X-12
Circuit Operation .....	X-12
PUNCH CODE SELECTOR .....	X-12
Punch Code Selector Application .....	X-14
CO-SELECTORS .....	X-14
PILOT SELECTORS .....	X-14



IBM 650 DATA-PROCESSING SYSTEM

# SECTION I. GENERAL PRINCIPLES

## General Features

The IBM 650 Magnetic-Drum Calculator has been developed to serve an increasing need for data-processing equipment to evaluate technical and accounting data. The 650 is completely self-checking without requiring the use of recalculation or special checking programs and consequently provides a high degree of reliability. It has a large memory capacity in the form of magnetic-drum storage and utilizes a system of stored programming that contributes to the ease of an operation and to flexibility in application.

The 650 is available in two models providing an optional main storage capacity for 1000 or 2000 *words*. A *word* consists of ten digits and an algebraic sign. Magnetic-drum buffer storage is provided between the main storage and the input and output units for increased speed of operation. Thus, the machine can be calculating while both the input and the output units are operating.

Words are stored serially on the drum. Furthermore, the digits of a word are stored serially within each word interval. Digits are represented by parallel combinations of magnetically stored bits. Information is thus said to be stored serially by word and digit, parallel by bit.

Two systems of digit representation by stored bits are used in the 650. The buffer storages and the arithmetic units use a bi-quinary system, where the presence of two of seven possible parallel stored bits determines the decimal value of the digit. All general storage uses a *two-out-of-five* bit system, where two of five possible parallel stored bits determine the decimal value of the digit. Each of the word storage positions on the drum is located by a four-digit code or *address*.

In the stored programming system used by the 650, each instruction (program step) is stored in a drum word-storage location as a ten-digit word.

When interpreted by the program control circuits, the coded digits of an instruction word give information as to which operation is to be performed, in which storage location to find the data to be used in performing the operation, and in which storage location the next ten-digit instruction word is to be found. A stored sequence of such instruction words forms a program, or *program routine*.

Calculations are performed by electronic means. The calculator can add, subtract, multiply, divide, and make logical tests, such as plus, minus and zero accumulator balance. The program routine can be altered by any of these logical tests or by sensing a control punch in a card. All arithmetical and logical operations are built in and require but little control panel setup. They are activated by the operation code portion of the instruction word.

The calculator will accumulate ten-digit words to develop a twenty-digit total, perform 10-digit  $\times$  10-digit multiplication to develop a twenty-digit product, and divide a nineteen-digit dividend by a ten-digit divisor to develop a ten-digit quotient and a ten-digit remainder. Sign control on all operations is automatic.

Unlike previous IBM calculators, the arithmetic units of the 650 are designed to handle numbers in a serial fashion. Thus, during calculations the ten-digit words are processed by the arithmetic units on a digit-by-digit basis with machine time progressing from the units digit through the highest order digit of a word. This is desirable, because information is serially available from storage for presentation to the arithmetic units.

The basic cyclical timings of the 650 are therefore related to digit position rather than digit value as in previous machines. In the 650 the value of a digit is determined by simultaneous combinations of bit pulses on two of the seven parallel information lines.

### Number Systems for Digit Representation

A recorded magnetic spot is essentially a binary storage device, because it may have either of two magnetic polarities depending on the direction of current flow through the writing head at the time the spot is written. Polarization in one direction is taken to mean a binary 1, while the opposite direction means a binary 0. Some system must be used so that a combination of these binary devices can represent the decimal digits 0 through 9.

In the 650 two such systems are used. The two-out-of-seven, bi-quinary, system is used for Read Buffer Storage (RBS) and Punch Buffer Storage (PBS) and the arithmetic units. The two-out-of-five system is used for general storage.

Figure I-1 shows how the bi-quinary system combines different binary 1 indications from two of seven parallel devices to represent each of the ten decimal digits. In the case of the read and punch buffer storages, the binary devices are recorded magnetic spots on seven parallel tracks. Successive 1 indications from the various combinations of two of the seven tracks during successive digit time intervals will indicate serially the decimal values of the digits of a word. In the case of the arithmetic units the paralleled binary devices are capacitor storage units. Seven parallel capacitors are used to represent each of the ten digits

Decimal Digit Value	Binary Level		Quinary Level				
	B5	B0	Q4	Q3	Q2	Q1	Q0
0	0	1	0	0	0	0	1
1	0	1	0	0	0	1	0
2	0	1	0	0	1	0	0
3	0	1	0	1	0	0	0
4	0	1	1	0	0	0	0
5	1	0	0	0	0	0	1
6	1	0	0	0	0	1	0
7	1	0	0	0	1	0	0
8	1	0	0	1	0	0	0
9	1	0	1	0	0	0	0

Track 1    Track 2    Track 3    Track 4    Track 5    Track 6    Track 7

Buffer Storage Band on Drum

Figure I-1. Bi-Quinary System

of a word. Each row is tested at its digit time by impulses from a drum-driven timing ring. Binary 1 indications from two of the seven capacitors will indicate the decimal value of the digit.

Notice that the bi-quinary system requires that there be a 1 indication from one and *only* one of the binary indicating devices in each of the two levels. It is this unique characteristic of the bi-quinary system that makes it easily adaptable to self-checking arrangements.

Notice also that the binary level indication determines whether the quinary level indication is to be read as it is or have five added to it to determine the decimal value. This above- or below-five characteristic of the system makes it easily adaptable to calculating circuitry.

Figure I-2 shows how the two-out-of-five system combines different binary 1 indications from two-out-of-five parallel devices to represent each of the ten decimal digits. This system is used only for general storage largely because of the saving of heads and circuits that it affords. This system requires that all information entering general storage passes through a seven-to-five conversion matrix and that all information leaving general storage passes through a five-to-seven conversion matrix.

Decimal Digit Value	Value assigned to each Binary Device				
	0	1	2	3	6
0	0	1	1	0	0
1	1	1	0	0	0
2	1	0	1	0	0
3	1	0	0	1	0
4	0	1	0	1	0
5	0	0	1	1	0
6	1	0	0	0	1
7	0	1	0	0	1
8	0	0	1	0	1
9	0	0	0	1	1

Track 1    Track 2    Track 3    Track 4    Track 5

1 General Storage Band on Drum

Figure I-2. Two-Out-of-Five System

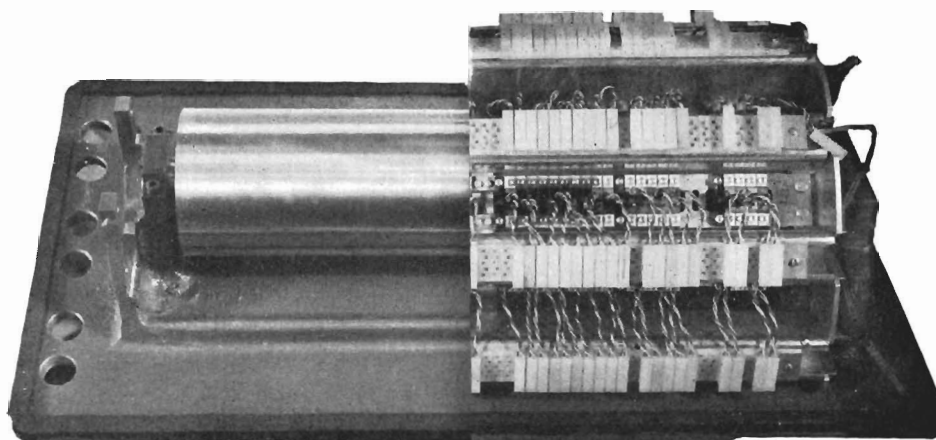

Figure I-3. Drum Assembly

### Drum Arrangement and Timings

The calculator is built around the magnetic drum (Figure I-3). This drum is a plated metallic cylinder about 4 inches in diameter and 16 inches long. Information is stored on its surface in the form of magnetic spots. In order to place information on the drum in an orderly fashion and to have the stored information available periodically, the drum must revolve. In the 650 the drum is driven at a speed of 12,500 rpm. Attached to the end frames and parallel to the axis of the drum is a number of mounting bars on which are mounted the inductive heads that read and write the information. Information stored on the drum is erased only by writing new information that may be read as often as needed without being destroyed.

The general storage portion of the drum has 2000 addressable locations where ten-digit words can be stored. Each of these word positions is located by first determining statically which one of the 40 five-track bands it is in across the drum, then dynamically which one of 50 angular drum positions it occupies around the periphery of the drum.

To accomplish head selection the four-digit address portion of the instruction word is placed in the address register where it activates the head selection

circuits. Both the static and the dynamic selection are determined by the numerical value of the four-digit address in the address register.

For static selection purposes the general storage portion of the drum is divided lengthwise into 40 five-track bands, one head per track. Each of the 40 bands has a six-bit track, a three-bit track, a two-bit track, a one-bit track, and a zero-bit track in accordance with the two-of-five system of digit representation. Fifty 10-digit words are stored serially by digit and word in each of these 40 bands, ten words in each of five drum timing sectors. This drum division is illustrated in Figure I-4.

In actual practice the five heads of a band are not physically adjacent but are displaced in a spiral fashion around the drum in such a way that the 6-bit heads are adjacent as are the 3, 2, 1, and 0 heads each in its lateral row. Figure I-5 illustrates this positioning, which is made necessary by the fact that the width of a head is somewhat greater than the width of a drum track. This spacing of the heads of a band in no way affects the machine operation, because information placed on the drum by simultaneous impinging of the heads of a band will later be available whenever the recorded spots pass under the same head positions during the same drum time interval.

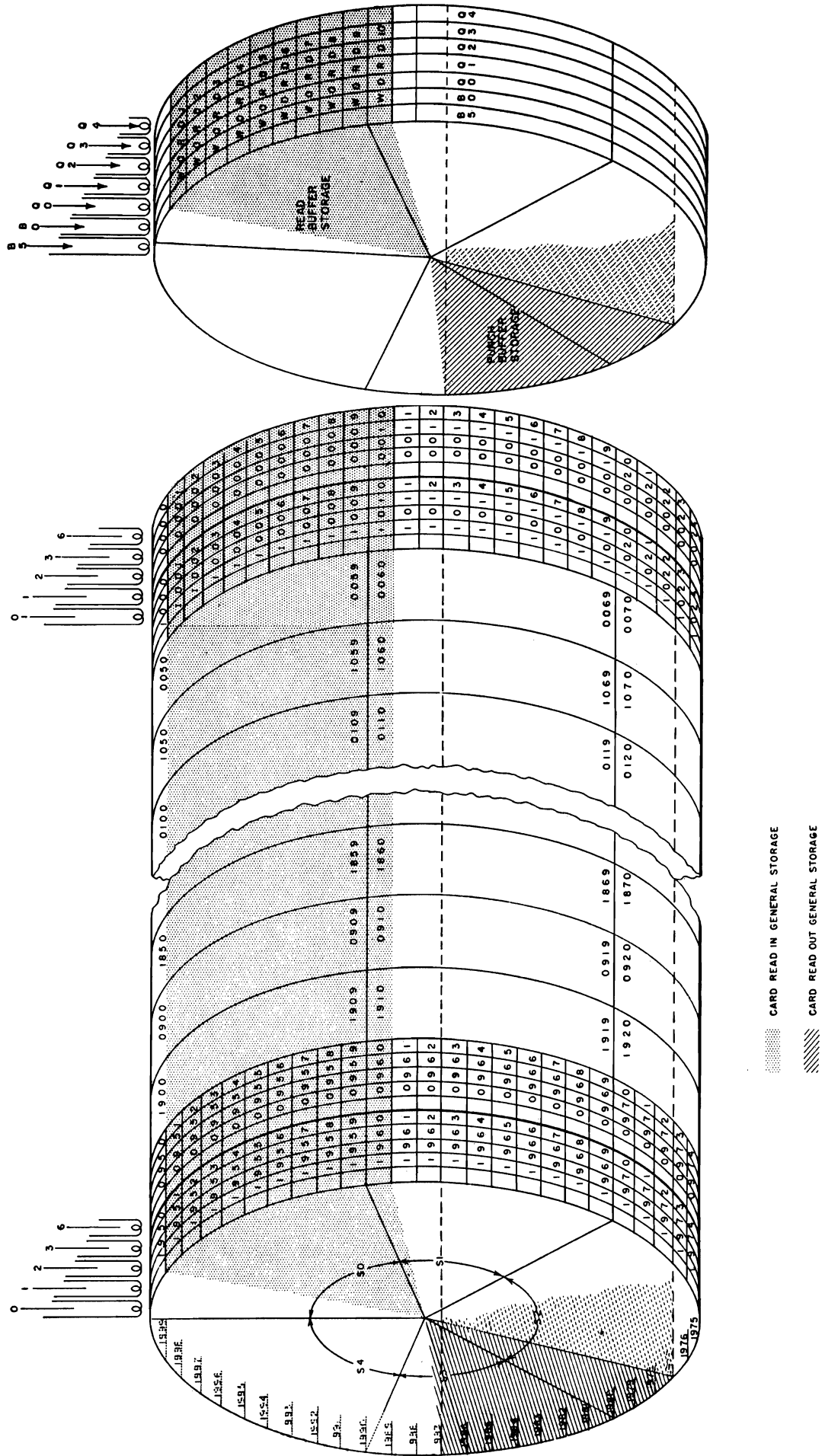

Figure I-4. Drum Arrangement



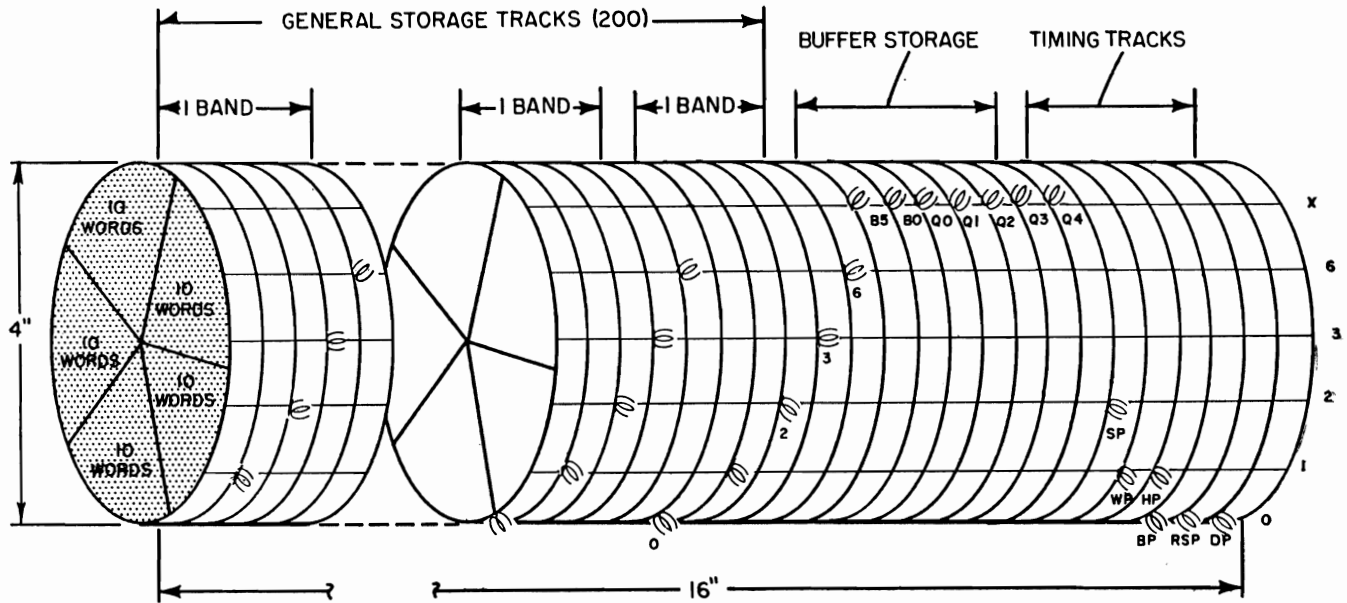

Figure I-5. Positioning of Heads

Figure I-6 illustrates the actual arrangement of the heads on the mounting bars around the drum. Notice from this figure that the seven buffer storage heads are mounted on the X-bar and are interspersed with the first six bands of general storage.

The four-digit address will appear in the address register in its bi-quinary form. The head selection circuits will select the proper five heads for reading or writing by interpreting the meaning of the four-digit bi-quinary address. Figure I-7 shows how the 2000 positions of storage are arranged, with both the decimal and bi-quinary meaning of the address digits.

To explain this arrangement one specific address shown on Figure I-7 will be analyzed. The bi-quinary form of address 0225 is

BQ BQ BQ BQ.  
00 02 02 50

In the address 0225, the B0H selects the right half of the drum, while Q2H selects 4 of the 20 bands in the B0H group, while B0T selects 2 of the 4 bands in the Q2H group, and Q0Th selects 1 of the pair.

The dynamic selection of one of the 50 words in the band is accomplished by the QT, BU and QU values of the address. For dynamic selection and other timing purposes, the drum is divided into five sectors (0-4) of 10-word intervals each (0-9). In the address 0225, the Q2T selects the third sector (sector 2), while B5U and Q0U select the sixth word interval in the sector.

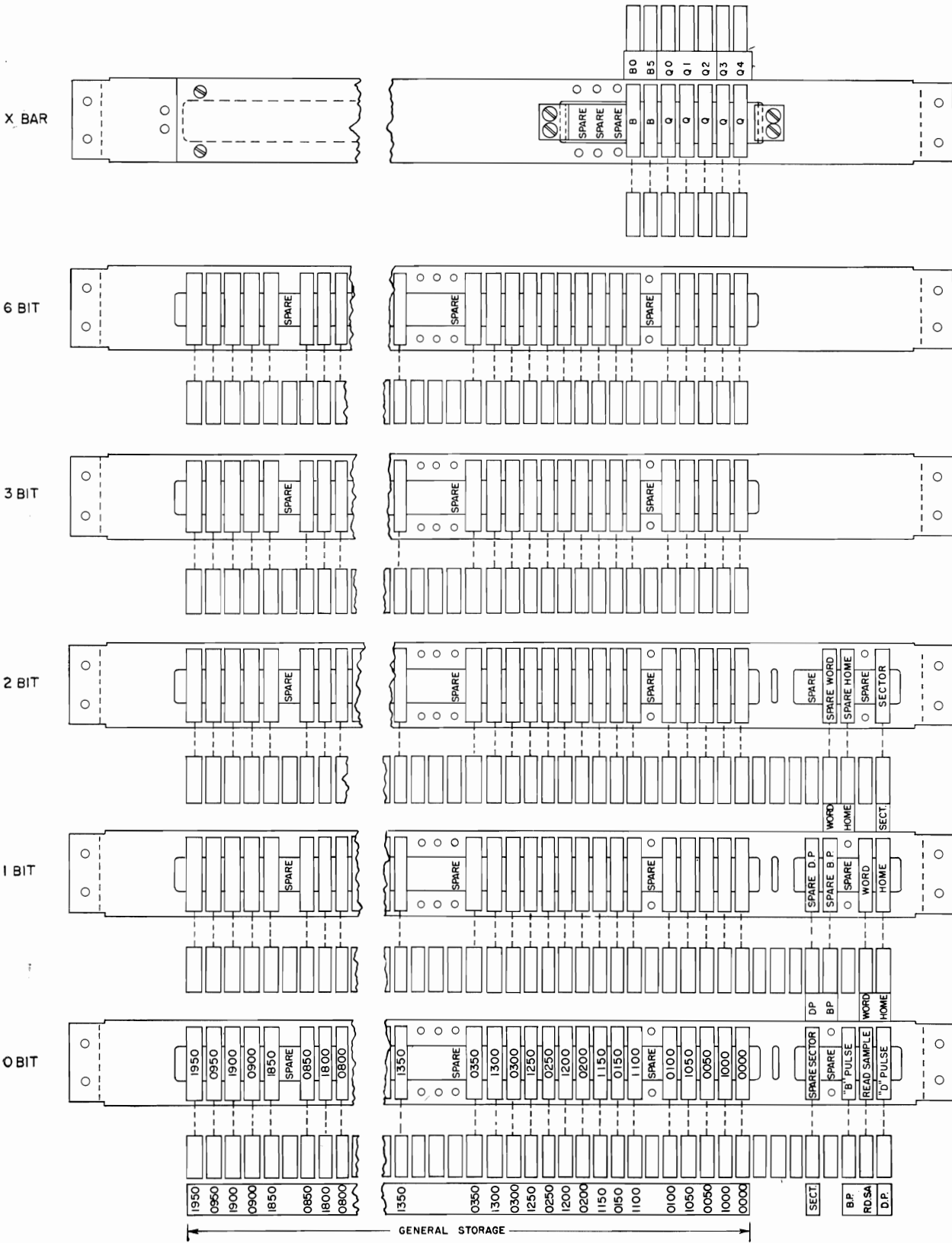

Figure I-6 Drum Head Layout

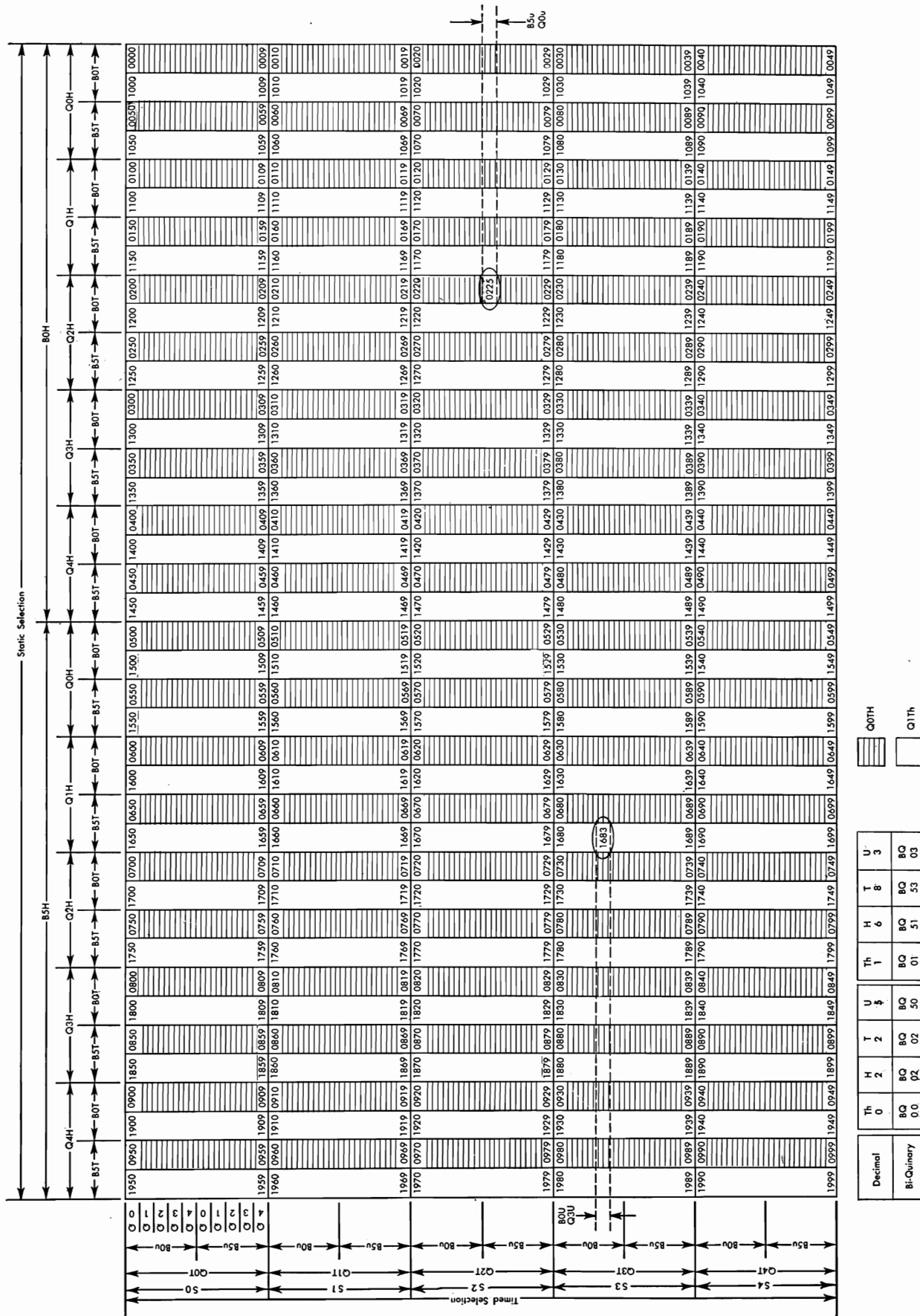

Figure I-7. Actual Drum Address Arrangement

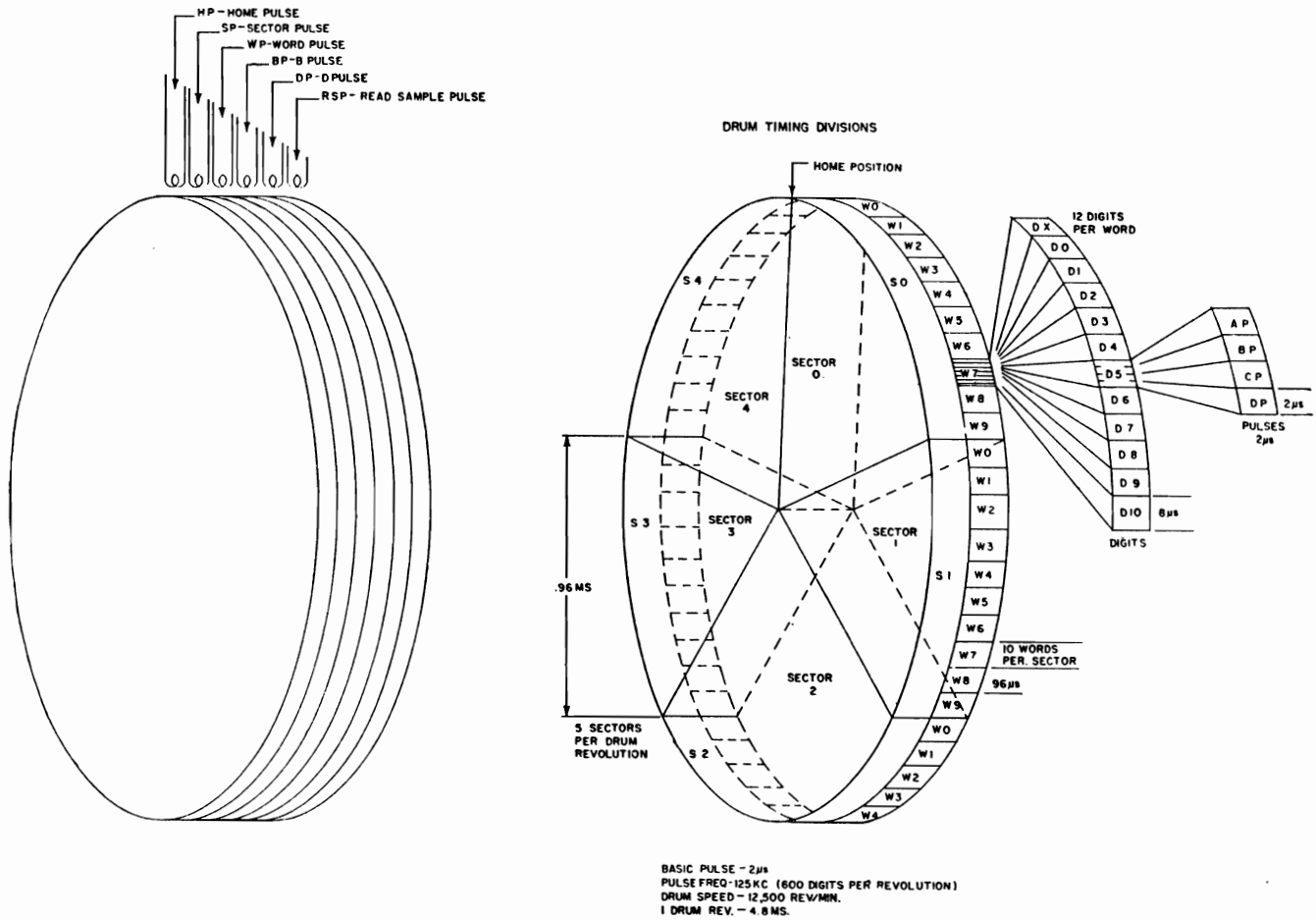

Figure I-8. Drum Timings

All machine timings are related to the angular positions of the drum. Figure I-8 shows the various important timing intervals and how they relate to the drum. The drum is divided into five sectors, each of which is divided into 10-word intervals. Each word divides into 12 equal-digit intervals, 10 digits, 1 sign position, and a separation interval called digit X (DX) between words. Each digit time is finally divided into four equal intervals A, B, C, and D.

The six timing tracks contain permanently recorded spots that are used to establish reference positions of the drum. These signals drive timing rings and pulse developing circuits that produce all of the timing pulses and gates used throughout the machine. The six recorded signals are:

1. Home pulse — 1 per revolution
2. Sector pulse—5 per revolution

3. Word pulse—50 per revolution
4. B pulse—600 per revolution
5. D pulse—600 per revolution
6. Read sample pulse—600 per revolution

The drum diameter is 4 inches. The circumference is 12.57 inches. The speed is 12,500 rpm (4.8 milliseconds or 4800 microseconds per revolution). Because there are 600-digit intervals around the drum, one-digit interval equals  $\frac{1}{600} \times 4800$  microseconds = 8 microseconds. Each A, B, C, and D pulse then is  $\frac{1}{4}$  of a digit time or 2 microseconds. The actual circumferential space occupied by a digit interval is  $\frac{1}{600} \times 12.57$  inches, or approximately .021 inch. Thus, the *spot density* is about 50 per inch.

Figure I-5 shows a seven-track storage band between the timing tracks and general storage. This is the logical arrangement of buffer storage heads. The

actual arrangement of buffer storage is shown in Figure I-6. This band is used for read-in and read-out buffer storage, called read-buffer storage (RBS) and punch-buffer storage (PBS), respectively. Both storages use the same band and the same heads for reading and writing, but they occupy different portions of the drum circumference and are thus written into and read from at different drum times. Digit values of words stored in read- and punch-buffer storage are represented in the bi-quinary system; thus seven tracks are used. Both storages have a capacity of ten words. All card input data enters general storage via RBS, and all output data from general storage must be punched via punch-buffer storage.

On read-in operations the parallel punched holes forming the digit notation of the words punched in the card are scanned by action of a cathode follower tube matrix and converted into serial form for storage in the 10 serial-word locations of RBS. At the same time the decimal punched hole notation is changed to the proper bi-quinary form of representation.

On read-out operations the serial pulses from the PBS read circuits that form the bi-quinary digit notation of the ten words in PBS are converted into single, punch cycle timed, pulses and distributed to the proper punch magnet for punching in decimal notation by action of a thyratron punch scanning matrix.

Both reading and punching are initiated by an operation instruction interpreted by the program control circuits. On a read operation, calculations are interrupted just long enough for the ten words in RBS to transfer to ten sequential general storage locations, the band is specified by the address portion of the read-operation instruction word. The time required to complete this transfer will be from a minimum of ten word times (960 microseconds) to a maximum of one drum revolution (4.8 milliseconds). The words so transferred entered RBS from the card that passed the reading brushes on the previous read operation. Calculations then restart and continue while the information from the next card is entering RBS at the slower card-reader speed.

On a punch operation, ten sequential words from general storage are transferred to the ten word positions of PBS from where they are scanned out to punch at punch speed. The general storage band location of these ten sequential words is specified by the address portion of the punch operation instruction word. The time required to complete this transfer from general storage to PBS will be from 960 microseconds to 4.8 milliseconds.

Figure I-9 illustrates RBS and PBS transfer times related to reader and punch cycles.

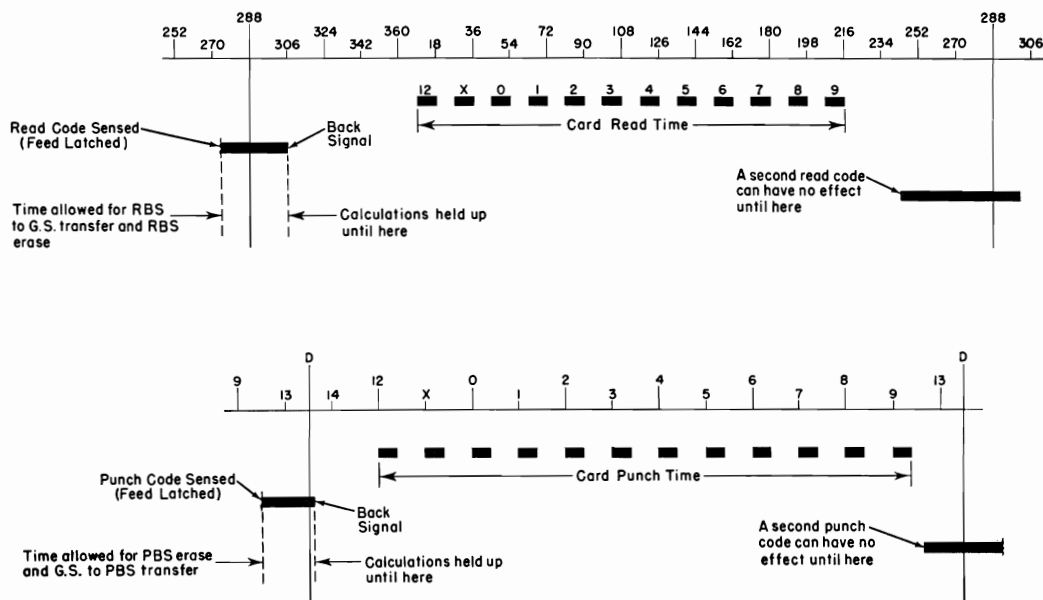

Figure I-9. Reader and Punch Cycles Showing RBS and PBS Transfer Times

One important limitation is imposed in transferring words between the buffer storage and general storage. The *block* transfer of ten words from RBS to general storage is accomplished by switching together the RBS *read* output circuits and the general storage *write* input circuits during the drum time that the words of RBS are passing their read heads. Similarly, a transfer of ten words from general storage to PBS is accomplished by switching together the general storage *read* output circuits and the PBS *write* input circuits during the drum time that the ten general storage words are passing their read heads. This means that only those general storage word addresses that occupy the same drum sector as the words of RBS can receive information from RBS. Only those general storage word addresses that occupy the same sector as the words of PBS can send information to PBS. Because there are 40 bands of general storage, there are 40 ten-word blocks or 400-word addresses, which can accept information from RBS and 40 *other* ten-word blocks, which can send information to PBS. These addresses will be specified in the section on *Programming*.

If it is desired to store original data or instructions in any general storage location other than one of these 400, a transfer must be programmed. This programmed transfer is usually part of a pre-stored transfer routine that is used to distribute original information to the desired general storage locations. Information to be punched must be placed by programming in one of the 40 general storage ten-word blocks associated with PBS. Notice that word locations in RBS and PBS are not addressable but function automatically on programmed read and punch operations.

The gray areas of Figure I-4 show the general storage positions that can be entered from RBS and those that can read out to PBS.

### Stored Programming

The 650 uses a system of stored programming to provide the necessary sequence of operations for the solution of a problem. Unlike previous machines that utilized control-panel wiring of a program device, the 650 refers to any of its own storage locations to ob-

tain a previously stored or computed ten-digit, coded instruction word whose digit values can be interpreted by the machine to determine what its next operation should be.

Original data and instructions are stored in drum storage locations from punched cards during the loading process. Additional data and/or instructions may be inserted from cards during the solution of the problem. Each instruction (program step) is stored as a word. Because both data and instructions are stored in the same manner, an instruction word can be subjected to arithmetical operations and thus can be altered by programming. The meaning of any valid coded instruction is built into the machine. Any sequence of instructions is called a program, or program routine.

All instructions are in the form of ten-digit words. The sign is carried along for checking purposes. It has no effect on the meaning of the instruction but must be considered when the instruction word is altered arithmetically.

The instruction word is divided into three sections (Figure I-10). Digit positions 10 and 9 are the operation code, which tells the machine which of its several operations to perform on this program step. Positions 8-5 are the *D*-address and usually mean either the location of information to be used in the operation, or the location where the information is to be stored as a result of the operation. In certain operations the *D*-address may have one of the following meanings:

1. The number of positions to be shifted either right or left.
2. The general storage band where the contents of the ten-word positions of RBS are to be entered on a read operation. Any one of the 50 addresses of a band used as the *D*-address of a read instruction word will cause a transfer of the ten RBS words to the word 1 through 10 locations of the band.
3. The general storage band from which information is to be punched. Any one of the 50 addresses of a band, used as the *D*-address of a punch instruction word will cause a transfer of the contents of word positions 27 through 36 of the band to the ten-word positions of PBS. The transferred information will be punched from PBS.

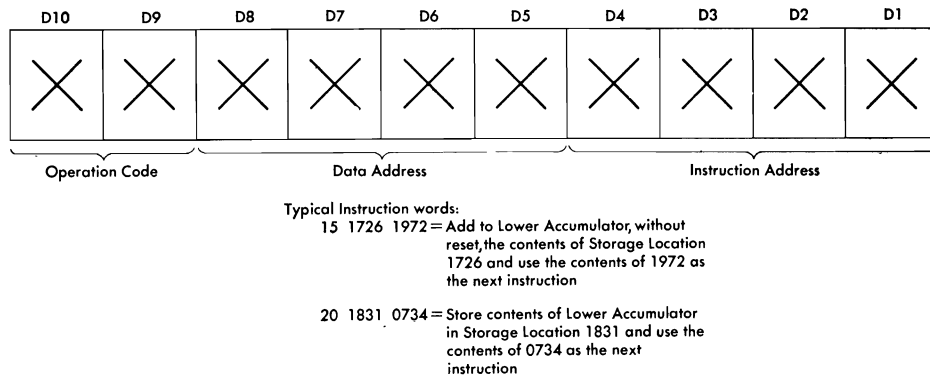

Figure I-10. Instruction Word Meaning

4. The location of an alternate instruction when selected by a branching operation. In any case the meaning of the D-address depends upon the associated operation code.

Positions 4-1 are the I-address that indicates the location in storage of the instruction word for the next program step, unless a branching operation has indicated the D-address is to be used for this purpose.

The following list shows all of the addressable storage locations in the 650:

Address	Location
0000-1999	General storage
8000	Control console storage entry switches
8001	Distributor
8002	Lower accumulator
8003	Upper accumulator

A more complete summary of addresses and op-codes will be found in a later section on *Programming*.

### Logical Organization, Data Flow, and Program Control

The general logical arrangement of the machine is shown in Figure I-11. The principal functional units and the various paths of information flow are shown.

It should be remembered that, although the data flow paths in Figure I-11 are shown as a single line to simplify the illustration, each data flow path actually comprises seven parallel lines. In accordance with the bi-quinary system, information pulses representing

the numerical value of each digit will be present on two of these seven lines during each digit interval.

The preceding article on *Drum Arrangement* explains that the original data and instructions enter the ten-word RBS section of the drum after passing through the converter circuits where they are changed from the parallel, decimal notation of the punched card to the serial, bi-quinary form of RBS. A programmed read operation causes a block transfer of the ten words from RBS to one of 40 ten-word general storage blocks marked *Card Read-In* (Figure I-11).

A programmed punch operation causes a block transfer of ten words from one of the 40 ten-word general storage blocks marked *Card Punch-Out* on Figure I-11 to the ten-word PBS section of the drum. These 10 PBS words then pass through the converter circuits, where they are changed from serial, bi-quinary form to punch-unit timed impulses for punching into the card in parallel, decimal notation. Figure I-11 also shows that all information entering the general storage section of the drum passes through a seven-to-five conversion matrix where the seven-bit, bi-quinary digit representation is changed to the five-bit code used for general storage. Similarly, all information leaving general storage passes through a five-to-seven conversion matrix where the five-bit representation is changed back to seven-bit, bi-quinary form. These seven-to-five and five-to-seven circuits are comprised of combinations of diode coincidence switches and diode OR circuits.

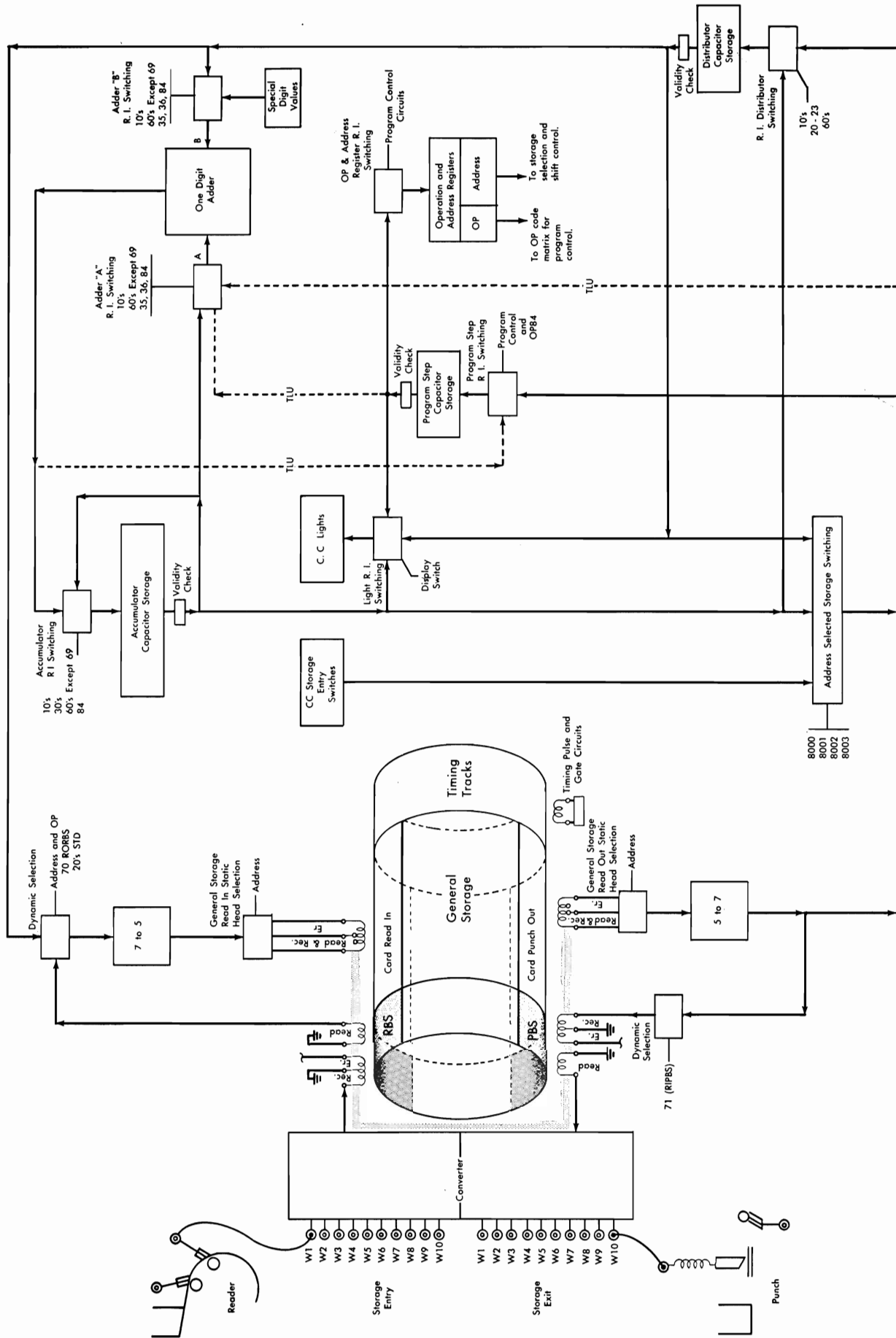

Figure I-11. 650 Logical Schematic



All of the arithmetical and logical operations that the machine can be programmed to perform such as add, subtract, multiply, divide, transfer of words to and from storage, shifting and logical tests are carried out by the action of the distributor, the accumulator and the one-digit matrix adder. The functionings of these units are controlled by the program control circuits of which the program step storage unit and the operation and address register are a part.

Each program step is performed in two parts, or *half cycles*. On the first part, or *I half cycle*, the operation and address registers are reset, and the *I*-address is placed in the address register where it is interpreted and used to select the location specified by the *I*-address. The new instruction word is then read out of the selected *I*-address location and into the program register. On the second part of the program step, or *D half cycle*, the operation and address registers are reset, and the operation and data parts of the new instruction word now in the program register are read out of the program register and into the operation and address registers. Here the *D*-address is interpreted and used to select the *D*-address. The data word is then read out of the *D*-address location and into the distributor. The operation code is interpreted and activates the operation, which is performed using the data now in the distributor. This completes this program step.

As soon as the operation is started, program control causes a return to the *I half cycle*. The operation and address registers are reset, and the *I*-address part of the instruction word in the program register is transferred to the address register, replacing the *D*-address, where it is interpreted and used to select the next *I*-address. The next instruction word is then read out of the *I*-address location and into the program register replacing the previous instruction word. The operation and address registers are again reset, and the operation and data parts of the new instruction word are read out of the program register and into the operation and address registers. At this point an interlock prevents further program advance except for read or punch operations, until the previous program step has finished using the arithmetic units. In this manner the machine advances through the steps of a stored program routine.

This half-cycle action, by which a program step is performed, is accomplished by a *program control commutator*, which controls the sequence of actions necessary to advance through any program step (Figure I-12). This control commutator is a two-branched ring with several positions in each branch. As it cycles, it alternately advances through each branch. The positions of one branch control the functions of the *I half cycle*, while the positions of the other branch control the functions of the *D half cycle*. Normally the ring must advance through both branches, first *I* and then *D*, to complete a program step. The outputs of the steps of the control commutator are used to control the various transfers of data required for the accomplishment of the program step.

Program step storage (program register) and the distributor are capacitor storage units capable of storing serially, in bi-quinary form, the ten digits of a word and of making continuously available serially, a bi-quinary signal representing each of the ten digits in its proper sequence, once every word interval ( $1/50$  drum revolution). Figure I-11 shows that both units receive information from a common storage exit channel, but the switching into program step storage is open only on an *I half cycle* while that controlling entry into the distributor is open only on a *D half cycle*.

The main function of program step storage is to hold the instruction word that it receives from the *I*-address, and supply the proper part of this word to the operation and address registers for interpretation, at the proper time.

The distributor acts as a buffer between the accumulating components and addressable storage locations. Its main functions are to receive a word of data from a selected *D*-address and to make this word available to the accumulating circuits as required by the operation, or to receive a word of data from the accumulating circuits or the control console switches and make this word available for entry into a selected general storage location. The distributor is also an addressable storage location (8001) and can be used as a source of information, through *selected storage switching*, to supply an instruction word to the program register.

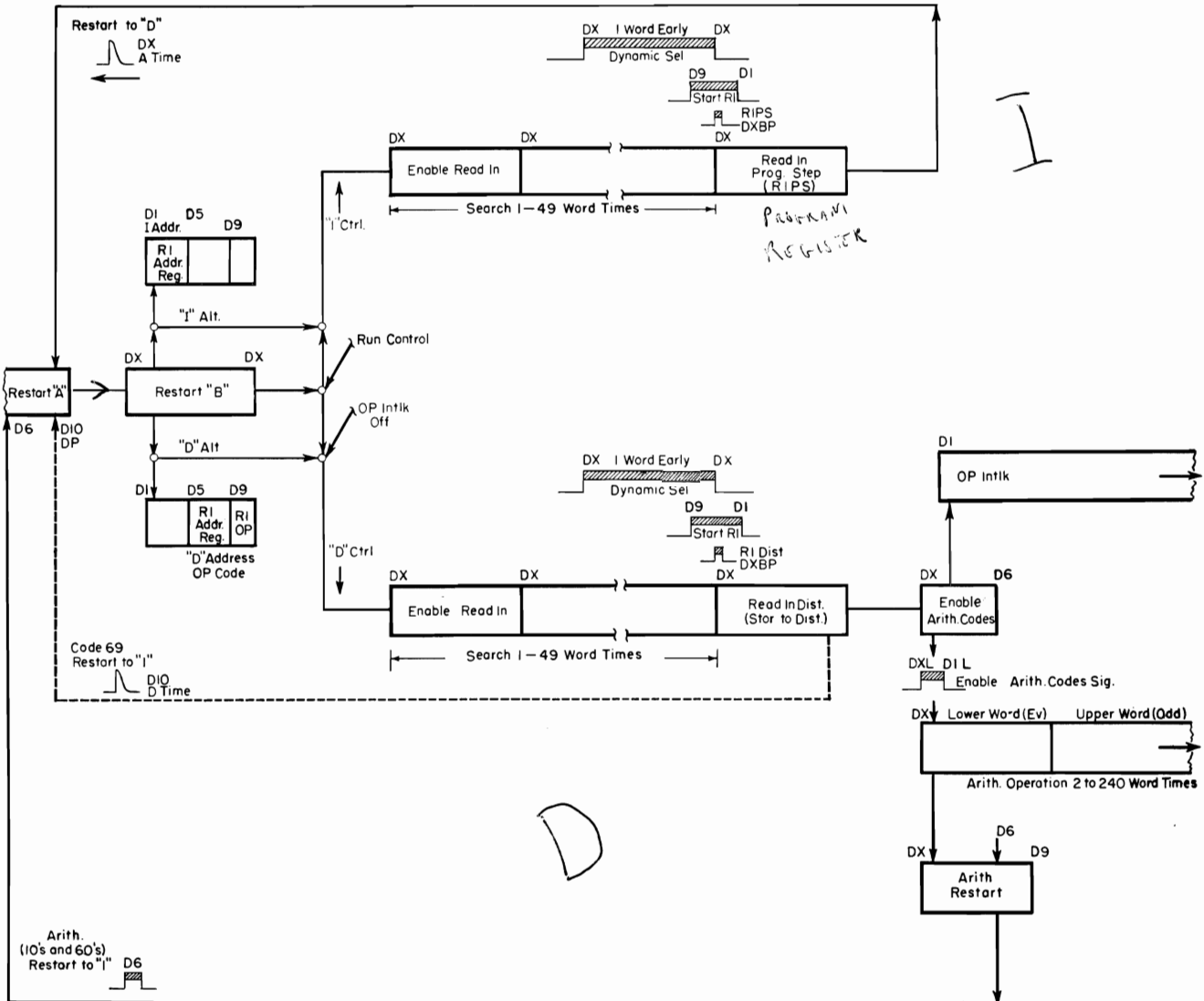

Figure I-12. Concept of Program Control Commutator

Capacitor storage units read out their stored information continuously during each drum word interval. This is done by driving the digit positions of the unit with drum timed-digit pulses from a drum driven digit ring. Each capacitor storage unit has a *one-digit-early* output and an *on-time* output. This is accomplished by driving each digit position of the unit with a drum time-digit pulse one-digit time in advance of the digit position of the storage unit. Thus, the digit-one position of the unit is read out at digit-zero drum time, digit two of the unit is driven at digit-one drum time, etc. Each early output is then delayed for a one-digit interval to provide an additional on-time output. Either output may be used depending upon the operation.

Capacitor storage units are a *non-sustaining* type of storage; i.e., each position requires periodic *regeneration* of its stored information. Regeneration is accomplished within the unit by providing a data flow path between the outputs of the unit and its input circuits. Thus, information that is available from the D1 position at digit-zero drum time is read back into the D1 position at digit-one drum time, etc., as long as the regeneration path is closed. Reading new information into a unit merely requires that the regeneration path be opened and that *on-time* output signals from the desired source be substituted at the storage unit input circuits in place of the units own *on-time* output signals. This is done whenever the input switching to the capacitor storage unit is activated.

Figure I-11 shows data flow paths from the outputs of all capacitor storage units. The information contained in any capacitor storage unit is continuously present serially, digit by digit, on these data flow paths. The data flow path from each of the capacitor storage units connects to the input switching circuitry of various other machine units; e.g., the distributor output connects to the adder *B* entry switching, selected storage switching, the control console light entry switching and the general storage entry switching. Reading information out of a capacitor storage unit requires merely that the entry switching for the desired receiving unit be opened for just the word time necessary to gate through the succession of output digit pulses representing the stored word.

The operation-code register is a two-position, bi-quinary, static storage unit. Each of its positions uses seven latches (electronic binary storage device) to indicate the operation-code value in bi-quinary form. It can accept information from the 9th and 10th positions of the program register on a *D* half cycle. Once a code is entered, a continuous, steady-state, bi-quinary output is available from two of the seven latches until the register is reset. These outputs are used in coincidence switching arrangements to control the indicated operation.

The address register is a four-position, bi-quinary, static storage unit similar to the operation code register. It can accept information from positions 5-8 of the program register on a *D* half cycle or from positions 1-4 on an *I* half cycle. Its continuous, steady-state, bi-quinary outputs are used by the general storage *read-write matrix* to select statically the proper storage band for reading out *I*- and *D*-addresses or for writing new information on programmed store operations and read operations. These outputs are also matched with the proper drum timing pulses by coincidence switching arrangements in the dynamic selection circuitry to select the proper word time for reading from or writing into a statically selected general storage band.

Operation code and address register outputs are also used as signals that help to control the advance of the program control commutator.

Figure I-11 shows that information from these registers is also instrumental in controlling selected storage switching in those cases where it is desired to use

the control console switches, upper or lower accumulator, or the distributor as a source of information, rather than a general storage location.

The accumulator is a capacitor storage unit similar to the program register and the distributor, except that it has a two-word capacity. The serial digit signals of each word are available at their proper *early* and on-time drum digit times once every *alternate* word interval. The accumulator is divided into two halves for programming and calculating purposes, the low-order ten digits form the lower accumulator, and the high-order ten digits form the upper accumulator. Information in the lower accumulator is continuously available during each even-numbered drum-word interval, while information in the upper accumulator is continuously available during each odd-numbered drum-word interval.

Figure I-11 shows data flow paths from the accumulator output to its own input, to one of the adder inputs, to selected storage switching, to the distributor, and to the control console lights. Transfer of information from either half of the accumulator to one of these destinations is accomplished by controlling the read-in switching of the receiving unit to be open for the proper even- or odd-word time, during which time the output of the desired half of the accumulator is gated through the receiving unit.

The upper accumulator also can act as an overflow for the lower accumulator when a sum or product exceeds ten digits.

The main function of the accumulator is to work with the adder in accumulating sums, products, and quotients, and in performing shift operations. It also supplies zero-balance, plus balance, minus balance, and over-flow signals to the program control circuits for the logical test operations and can function as an addressable source of information (8002 or 8003) to supply an instruction word or a data word for programming purposes.

The one-digit adder is a diode and tube unit capable of receiving two input digit values, analyzing them, and producing a digit output signal equal in value to the sum of the two input values. The distributor and the accumulator feed into the one-digit adder. The output from the one-digit adder is stored back in the accumulator. A delay of one digit time is incurred between input to and output from the adder. An out-

put will be available from the adder only as a result of the entry of two input digits, one on each input line.

Digits from both the distributor and the accumulator can enter the adder—the distributor digits on one input line and the accumulator digits on the other. Provision is also made, in certain operations, for blanking the distributor or accumulator digit values and substituting zeros or constants for entry into the adder. Most calculator operations are performed by merging distributor and accumulator digit values or their substitutes in the adder and storing the result back in the accumulator. In most arithmetical operations the distributor and accumulator early output is used to produce an on-time adder output for the accumulator to store. In other operations such as shifting, the on-time output may be used.

### Summary of Various Data Flow Paths

Digits can enter the distributor from any general storage location, from the entry switches on the control console or from either half of the accumulator. The selected storage path is used between the accumulator and distributor on arithmetical operations when the D-address is either half of the accumulator. The direct path is used on a Store-Accumulator operation. In this case the D-address is a general storage location meaning the destination of the word in the accumulator. The distributor can supply a word of information to the adder, to any general storage location, to the display lights on the control console (manual operation), or to the program register through *Selected Storage* switching.

The accumulator can be entered only from the output of the adder or from its own output (in certain shifting operations). The accumulator can supply information to the adder, the distributor directly, the distributor or the program register through selected storage switching, or the display lights (manual operation).

The program register can be entered from the common storage exit line (either general storage output or selected storage) or from the adder on a *table lookup* operation. The program register can supply information to the operation and address registers, the display lights, or to the adder on a table lookup operation.

The operation and address registers can be entered from the program register. The operation and data part of an instruction word is transferred on a D half cycle, the I part on an I half cycle. The operation and address register static outputs control general storage head selection, the machine operation, selected storage switching, and the control commutator.

The adder normally accepts information simultaneously from the accumulator and distributor and supplies information to the accumulator. It can also receive data from the program register and read out to the program register on table lookup operations.

General storage can be read into from either read buffer storage or the distributor. General storage can read out either to PBS, the program register, the distributor, or to the adder on a table lookup operation.

The control console storage entry switches (8000) can read out to selected storage and thus to either the program register or the distributor.

The dotted lines on Figure I-11 are the additional flow paths that are used only on the table lookup operation.

### Physical Organization

The machine is comprised of three basic physical units interconnected by cables. The 533 Read-Punch Unit, the 655 Power Unit, and the 650 Console Unit.

#### 533 Read-Punch Unit

The 533 Read-Punch Unit is basically a high-speed punch similar to the 523 and the 402 Card Feed Unit, both mounted on a 528 base. The card reader is used to read information into the calculator, while the punch unit is used to record information taken from the calculator. The only control panel is on the 533 unit and is used primarily for designation and selection of input and output card fields, although some control of the calculator is possible. Input from the card reader is at 200 cards per minute. A maximum of 80 columns and 10 signs can be read from an 80-column IBM card. Selectors are provided to allow selection of input fields. Provision is made for card control of program routines.

The punch operates at 100 cards per minute. A maximum of 80 columns and 10 signs can be punched into an 80-column IBM card. Selectors that can be picked from the calculator are provided for output selection.

### 655 Power Unit

The 655 Power Unit houses most of the power supply components used to provide the various necessary voltages. This unit also contains the read and punch scan matrices and associated circuits for converting to and from the parallel, decimal, punched-hole notation of the input and output cards and the serial, bi-quinary notation required by the drum storage.

### 650 Console Unit

The 650 Console Unit contains the magnetic drum, its associated read and write circuits and all calculating and program control circuits. In addition, it mounts the operator's control console, which contains switches and indicating lights for operation of the machine.

### Current Requirements, Dimensions, Weight, and Heat-Dissipation Data

Data given for machines manufactured prior to February, 1956, except otherwise noted.

	<i>Height</i>	<i>Width</i>	<i>Length</i>	<i>Approx. Weight</i>
650 Console Unit	71"	30 $\frac{5}{8}$ "	62 $\frac{1}{8}$ "	1800 lbs.
655 Power Unit	71"	30 $\frac{5}{8}$ "	62 $\frac{1}{8}$ "	2400 lbs.
533 Read-Punch Unit	49 $\frac{1}{8}$ "	25 $\frac{5}{8}$ "	57 $\frac{5}{8}$ "	1200 lbs.

The power requirement is either 230 or 208 volts, with  $\pm 10\%$  regulation. 100-ampere service  
 50-60 Cycles 48,300 B.T.U./hour heat  
 Single-phase or three-phase dissipation

Approximately 58,300 B.T.U./hour heat dissipation for machines manufactured after February, 1956.

### Self-Checking

The accuracy of calculations is achieved by checking the transmission of all data and instructions to satisfy the validity requirement that there be one and only one bit in each level (binary and quinary) of a digit. Punched information is checked by double-punch, blank-column-detection circuits. When a validity check error occurs, the machine may be stopped or the program routine may be *branched* to repeat a portion of the problem or to initiate a different problem.

Figure I-11 shows the location of these validity check circuits, at the output of each of the capacitor storage units. Because all information eventually passes through these units, any invalid combinations will be detected.

In addition to these validity checking features, the program control circuits and the arithmetic circuits are designed with inherent checking features and *fail safe* logical arrangements as far as is economically possible. These control checks are dependent upon the proper combination of signals within the machine, the proper sequence of signals, double circuitry, and back signals, which insure that the signal to perform some operation was received and that the operation was completed before proceeding to the next step.

A special check assures that information is entered into only one general storage location on any general storage *write* operation.

Meaningless address and operation codes are detected and cause an error indication.

The timing rings are continuously checked on each cycle of their operation. Any timing error is detected and causes a timing error indication.

A continuous check is made of the accumulator for an accumulator overflow or a quotient of more than 10 digits. An overflow condition can cause a machine stop or can be used to branch the program routine.

## SECTION II. BASIC PRINCIPLES

### PROGRAMMING

TO SOLVE a problem on the 650, original data words and instruction words must first be loaded into storage locations on the drum from punched cards. The information to be punched in the loading cards is first written on a program sheet or planning chart in the numerical codes of the machine. Each line on this chart then represents either a word of data to be used on a program step or a word of instructions to be carried out on a program step. The coded information on each line of the chart is punched into the loading cards. Often several lines of coding are punched into several fields of one card and loaded into the specified storage locations by means of a previously stored loading routine.

#### Storage Address and Operation Codes

The addresses of all storage locations and the meaning of the operation codes follows:

<i>Address</i>	<i>Unit Addressed</i>
0000-1999	General storage (General storage address can be either a source of information or a destination for information depending on the OP-CODE meaning)
8000	Storage entry switches
8001	Distributor
8002	Lower accumulator
8003	Upper accumulator

General storage locations that are in the same angular position on the drum as word 0001-0010 can receive information from RBS. There are 10 words in each of the forty bands that can be transferred into from RBS (Figure I-4).

There are other locations in general storage from which information may be transferred to punch buffer storage. These are the locations in each of the forty bands that occupy the same angular position

on the drum as PBS. The band is determined by using any one of the fifty addresses within a band as the D-address of the punch instruction. In the 0000 band the punch-out positions are words 27-36.

The two-digit operation codes represent the various built-in operations that the machine can perform.

In the case of the arithmetic codes (10's and 60's), the D-address of the instruction word specifies the location of the addend, subtrahend, multiplicand, or divisor. In these operations the operand or operator is transferred from its storage location to the distributor. It is then added or subtracted into the accumulator as required by the operation. After the operation is complete, the original operand or operator remains in the distributor. The next instruction is taken from the location specified by the I-address.

In the case of store codes (20's), the D-address specifies the location where the number is to be stored. The information contained in a general storage location is automatically erased as the new number is entered. The stored number is also available in the distributor after completion of the store operation. The contents of the accumulator is not affected by a store operation.

#### Summary of Operation Codes

The following summary of operation codes is provided, without the detailed description, for easy reference.

To simplify the use of these codes, and as an aid in understanding the program control circuits, which will be considered in a later section, notice that the operation codes can be grouped into seven classifications according to their meaning. Also notice that each of the codes in one of these seven classifications has a common ten's position numerical value. Remember that within the machine, the codes and addresses appear in their bi-quinary form in the operation code and address registers where they are interpreted.

<u>Code</u>	<u>Abbreviation</u>	<u>Operation</u>
00	NO OP	No Operation
01	STOP	Stop
10	AU	Add to Upper
11	SU	Subtract from Upper
14	DIV	Divide
15	AL	Add to Lower
16	SL	Subtract from Lower
17	AABL	Add Absolute Value to Lower
18	SABL	Subtract Absolute Value from Lower
19	MULT	Multiply
20	STL	Store lower
21	STU	Store upper
22	STDA	Store Lower Data Address
23	STIA	Store Lower Instruction Address
24	STD	Store Distributor
30	SRT	Shift Right
31	SRD	Shift and Round
35	SLT	Shift Left
36	SCT	Shift Left and Count
44	BRNZU	Branch on Non-zero in Upper
45	BRNZ	Branch on Non-Zero
46	BR MIN	Branch on Minus
47	BR OV	Branch on Overflow
60	RAU	Reset-Add to Upper
61	RSU	Reset-Subtract from Upper
64	DIV RU	Divide-Reset Remainder
65	RAL	Reset-Add to Lower
66	RSL	Reset-Subtract from Lower
67	RAABL	Reset-Add Absolute Value to Lower
68	RSABL	Reset-Subtract Absolute Value from Lower
69	LD	Load Distributor
70	RD1	Read into Input Storage Area 1
71	WR1	Write (Print or Punch) from Output Storage Area 1
72	RC1	Read Conditional into Input Storage Area 1
84	TLU	Table Lookup
90	BRD 10	Branch on 8 in 10th Position of Distributor
91	BRD 1	Branch on 8 in 1st Position of Distributor
92-99	BRD 2-9	Branch on 8 in 2nd through 9th Position of Distributor

Figure II-1. Operation Codes

0's NO-OP and STOP

10's Arithmetic codes. Notice that *binary* value of the ten's position determines the reset—no-reset meaning of the code. The quinary part of the ten's position and all of the units positions are the same.

20's Store codes

30's Shift codes

40's Test codes. Here the binary value of the ten's positions determines whether the accumulator or the distributor is to be tested.

90's

70's Input and Output codes

84 Table Lookup. Only one code is used in the 80 series

Figure II-1 shows the operation codes and abbreviations that are used in the 650.

### Examples of Programming

To explain the use of the addresses and operation codes, a simple problem is shown. Figure II-2 shows the lines of coding that might be used to solve the

$$\text{problem } \frac{(A + B - C) D}{E}$$

In this example the values of the factors are:

(A+B-C)D  
E

PROBLEM: \_\_\_\_\_ WRITTEN BY: \_\_\_\_\_

INSTR NO	LOCATION OF INSTRUCTION	OPERATION		ADDRESS		REMARKS
		ABBRV	CODE	DATA	INSTRUCTION	
	8000	RD	70	0051	0101	
	0051		00	0000	0291	Data, Factor A
	0052		00	0000	9842	Data, Factor B
	0053		00	0000	0133	Data, Factor C
	0054		00	0000	0020	Data, Factor D
	0055		00	0000	0200	Data, Factor E
	0101	RAU	60	0051	0102	A in Upper Acc. (291)
	0102	AU	10	0052	0103	A + B in Upper Acc. (10133)
	0103	SU	11	0053	0104	A + B - C in Upper Acc. (10000)
	0104	MULT	19	0054	0105	(A + B - C)D in Lower Acc. (200 000)
	0105	DIV RU	64	0055	0106	(A + B - C)D + E in Lower Acc. (1000)
	0106	STL	20	0027	0107	Store 1000 in card punch out G. S.
	0107	PCH	71	0027	8000	Punch Card (1000 in W1 field)

Figure II-2. Program Planning Chart for  $\frac{(A + B - C)D}{E}$

$$A = 291 \quad D = 20$$

$$B = 9842 \quad E = 200$$

$$C = 133$$

Then 
$$\frac{(A + B - C) D}{E} =$$

$$\frac{(291 + 9842 - 133) 20}{200} = 1000$$

The first five locations on the planning chart will contain the data to be used (factors A, B, C, D, E). The other locations will contain the instructions to be performed. The sequence in which the instruction locations appear as I-addresses determines the sequence of the program routine.

After the problem is programmed on the chart, the words of data and instructions must be entered into locations 0051-0055 and 0101-0107, as indicated by the chart. On a simple problem such as this one, loading could be done from the operator's console by setting the word values in the storage-entry switches and the locations in the address switches and entering each word on the chart into its programmed location, line by line.

This would be a slow process, however, when the problem is long or when programming for many different problems must be loaded frequently. In practice the words to be stored are punched in loading cards and placed in their proper locations by means of a pre-stored loading program or loading routine.

### Loading

Loading routines can be designed to suit the particular needs of any user. Flexibility in the arrangement of rapid loading routines is possible because of the stored programming feature and is aided by the arrangement of 400 specific general storage locations into 40 ten-word blocks, each of which can be instructed to accept up to 10 words from one card via read-buffer storage. The ten-word blocks are formed by the last 9 word-storage locations in sector 1 and the first in sector 2 (Figure I-4).

The data and instructions comprising a loading routine are normally entered into storage locations on the drum either from cards or from the operator's console. The locations so used may never be used for any other purpose, so that the loading program is permanently stored and always available whenever needed. On the other hand the loading program may be entered into the machine just prior to the loading of a large quantity of data or instructions. This latter case is perhaps the most reliable. When this method is used, there is no danger of the loading program being destroyed by subsequent programming, and it allows full use of the storage capacity of the machine.

Two methods of card loading will be explained to illustrate some of the principles of loading procedures. One of these methods requires a few pre-stored instructions; the other none. Both have the advantage of being able to load information into any general storage location in the machine.



Standard Reference Codes	Block No.	Card No.	Location of Instruction	Instruction	Operation Abbrev.	8003 Upper Accumulator	8002 Lower Accumulator	8001 Distributor	Remarks
0-Normal Instruction			8000	70 0001 0058	RD				Read. If load card go to 0001 for next instr. Load Distributor with instr. to be stored Store instruction in specified location.
			0001	69 0004 0003	LD				
			0003	24 ---- 8000	STD				
1-Instruction Developed by 650 and Temporary Storage									
2-Constant									
3-Sheet Heading									
4-Additional Description									

LOADING ROUTINE - ONE WORD PER CARD  
SET - UP

1. Set Storage Entry Switches to 7000010058
2. Set Control Switch to RUN
3. Press Computer Reset Key
4. Press Program Start Key

Figure II-3. Loading Routine—One Word per Card

Figure II-3 shows the planning chart and card arrangement for the simpler of these loading procedures. With this method, one word of a planned routine is loaded per card. Thus, one loading card will be required for each line of coding on the planning chart of the problem to be solved. No previously stored instructions are necessary for this routine. Only one control-panel wire is necessary from the column, which contains the loading card identification, to the LOAD hub.

This wire does two things:

1. Allows the word 1 field of the card (cols. 1-10) to enter storage entry 1 (first word position of RBS), word 2 field (cols. 11-20) to enter storage entry 2 (second word position of RBS), etc. These entries are accomplished without any column to storage control-panel wiring.
2. Indicates to the calculator that the card was a loading card, so that the next instruction will be taken from the D-address of the read instruction instead of the I-address.

After these cards are punched, they are placed in the read hopper, face down, 12-edge first. The read start key is depressed, resulting in three run-in cycles, at which point the read start key is no longer effective.

During the third run-in cycle the information in the three punched word fields of the first load card has automatically entered the first three word storage positions of read-buffer storage, and the load card back-signal control relay has been picked.

As shown in Figure II-3 the first instruction of the loading routine (70 0001 0058) is set in the storage-entry switches on the control console (location 8000). The control switch is set to RUN, and the computer reset key is depressed. This use of the computer reset key, resets the program register, distributor, and accumulator to zeros and, because the control switch is in the run position, resets the address register to 8000. It also insures that the control commutator will begin in an I half cycle. The program start key is depressed, allowing the control commutator to advance through its I half cycle. Because the address in the address register is 8000, the contents of the storage-entry switches will be transferred to the program register on this I half cycle. Upon completion of this transfer, the control commutator will signal a restart to D, and during the restart word time the OP and D portion of the instruction in the program register will be placed in the operation code and address registers (70 0001).

At the end of the restart word time, the 70 output from the operation code register will cause an *advance read feed* signal and will energize the read-buffer storage transfer and erase control circuits, resulting in a transfer of the contents of RBS to the card read-in positions (words 1-10) of the general storage band indicated by the address register (0001 band 0000-0049), and the subsequent erasure of RBS to blanks. This transfer and erase action occurs while the read clutch is being energized and during the first few degrees of the reader cycle. At 300° a reader cam (R57) sends a back signal to the back-signal control relay. As this relay is up, because of the load card impulse on the last reader cycle, the cam back signal is diverted from its normal restart action to a *Use D* signal.

The *Use D* signal flips the alternation control latch of the control commutator, removing the *D* signal and replacing it with an *I* signal, so that as the commutator advances from the restart word it will proceed through its *I* branch. No restart signal is given; thus the operation and address registers are not reset. As the commutator advances through its *I* half cycle, the address in the register is still the *D*-address of the read instruction (0001). This address now is used as the location of the information to be read into the program register.

Because 0001 now contains the first word of the first load card (69 0004 0003), this instruction is read into the program register, and a restart to *D* is again signalled. Note that if the back signal control relay had not been up, a normal restart to *I* would have occurred, resulting in a reset of the operation and address registers and a transfer of the *I*-address of the read instruction (0058) to the address register. The next instruction would then have been read into the program register from location 0058 instead of 0001.

During the restart word the operation and address registers are reset and the operation and *D* parts of the instruction in the program register are placed in the operation and address registers (69 0004). During the *D* half cycle the operation and address register outputs signal the head selection circuits to choose general storage band 0000-0049 and the control commutator to open up distributor read-in switching at such a time that the contents of 0004, which is the word to be loaded, will be transferred to the distributor.

Upon completion of the distributor read-in, a restart to *I* is signalled, the *I*-address (0003) is placed in the address register and the next read-in to the program register is from 0003 (24—8000). On the next *D* half cycle the word to be loaded, now in the distributor, is placed in the specified *D*-address by the direction of the *store distributor*, operation code 24. The next instruction is taken from the switches, which feeds another card and causes a repetition of these steps. In this way the information required for the problem is placed in the general storage locations specified by the problem planning chart.

During the *D* half cycle in which the last load card information is transferred from read buffer storage to general storage, the following data card passes the second brushes. Data cards do not contain the load card 12 punch. Therefore, when the machine completes the next code 70 (code 70 for the first data card) *D* half cycle, a normal restart to *I* is signalled.

In this example location 0058 was arbitrarily chosen as the *I*-address of the read instruction. Any other general storage location could be used.

With this procedure, one word can be loaded per card. It would require 2000 cards to load the machine to capacity. Because cards feed through the reader at 200 cards per minute, it would require 10 minutes to load the machine. The disadvantage is the relatively large number of cards to be punched and verified.

Figures II-4 and II-5 show a planning chart and card form for a loading procedure that can load up to four words from one card in any general storage location. This program will load the information punched in the word 1 field of the card into the location specified by the *D*-address of word 2; word 3 into the *D*-address of word 4; etc. This procedure requires that the *I*-address of the *last* instruction be 8000.

In the card shown, four words are to be loaded. If fewer than four words are punched, the *I*-address of the last instruction on the card, whether it be the first, second, or third must be 8000. This loading routine requires that locations 1950, 1961, 1962, and 1963 contain the pre-stored instructions and constants indicated on the planning chart. This information can be initially placed in these locations manually from the the control console or by means of the previously described one-word-per-card, loading routine.

LOADING ROUTINE - FOUR WORDS PER CARD

SET - UP

1. Set Storage Entry Switches to 70 1961 (XXXX)<sub>0</sub>
2. Set Control Switch to "RUN"
3. Press Computer Reset Key
4. Press Program Start Key

Loc. of Instruction	OP	Instruction		Operation Abbrev.	8003 Upper Accumulator										8002 Lower Accumulator										8001 Distributor										Remarks
		Date	Instr.																																
1st Word	✓ 8000	70	1961	(XXXX) <sub>0</sub>																															RD into 1951-1960, if load card use D
	✓ 1961	65	1962	1950																															RAL from 1962
	✓ 1950	15	1963	8002																															AL from 1963
	8002	69	1951	1952																															LD from 1951 Word 1 from card
	1952	24	(XXXX) <sub>1</sub>	1950																															STD in XXXX <sub>1</sub> Word 1 now in (XXXX) <sub>1</sub>
2nd Word	1950	15	1963	8002																															AL from 1963
	8002	69	1953	1954																															LD from 1953 Word 3 from card
	1954	24	(XXXX) <sub>2</sub>	1950																															STD in XXXX <sub>2</sub> Word 3 now in (XXXX) <sub>2</sub>
3rd Word	1950	15	1963	8002																															AL from 1963
	8002	69	1955	1956																															LD from 1955 Word 5 from card
	1956	24	(XXXX) <sub>3</sub>	1950																															STD in XXXX <sub>3</sub> Word 5 now in (XXXX) <sub>3</sub>
4th Word	1950	15	1963	8002																															AL from 1963
	8002	69	1957	1958																															LD from 1957 Word 7 from card
	1958	24	(XXXX) <sub>4</sub>	8000																															STD in XXXX <sub>4</sub> Word 7 now in (XXXX) <sub>4</sub>
Repeat	8000	70	1961	(XXXX) <sub>0</sub>																															RD into 1951-1960, if load card use D (Repeat)
	✓ 1962	69	1949	1950																															Data (Skeleton Instruction)
	✓ 1963	00	0002	0002																															Constant (To modify skeleton instr.)

NOTE: (XXXX)<sub>0</sub> can be the starting address of the problem to be solved.

NOTE: ✓ shows pre-stored information and addresses where stored (1950, 1961, 1962, 1963).

Figure II-4. Loading Routine—Four Words per Card

An advantage of this loading procedure is that it can load the machine with fewer cards. Only 500 cards would be needed to load the machine to its capacity. It retains the flexibility of being able to place any word in any storage location, an advantage when loading optimum-coded program routines. Notice that this procedure makes use of the machine's ability to alter instructions arithmetically.

Other routines can be devised that will load up to seven 10-digit words per card, one field being used for a loading instruction. These procedures, however, are usually subject to the limitation that the location of the first word on the card is specified, and the remaining words will be placed in successive or constantly spaced storage locations. The only advantage is the decrease in the volume of load cards to be punched and verified, because actual machine loading time, even at the rate of one word per card, is usually a negligible part of the total time required to solve a problem.

Refer to the planning chart for the sample problem

$$\frac{(A + B - C) D}{E} \quad (\text{Figure II-2})$$

The lines of coding that make up this problem could be loaded by using either of the two preceding loading procedures. The cards that would be required to load this problem, using the four-word-per-card routine, and factor cards for the solution of two problems, are shown in Figure II-6. To start this problem these cards are placed in the read feed hopper, face down, 12-edge first. The read start key is used to feed the first card past the second brushes. At this point its information will be in the first eight word positions of read-buffer storage. The four steps of the setup procedure of Figure II-4 are then performed, and the data and instructions contained in the cards are entered. In this case 0101, the starting address of the problem, is used as the I-address of the read instruction word (XXXX) set in the switches.

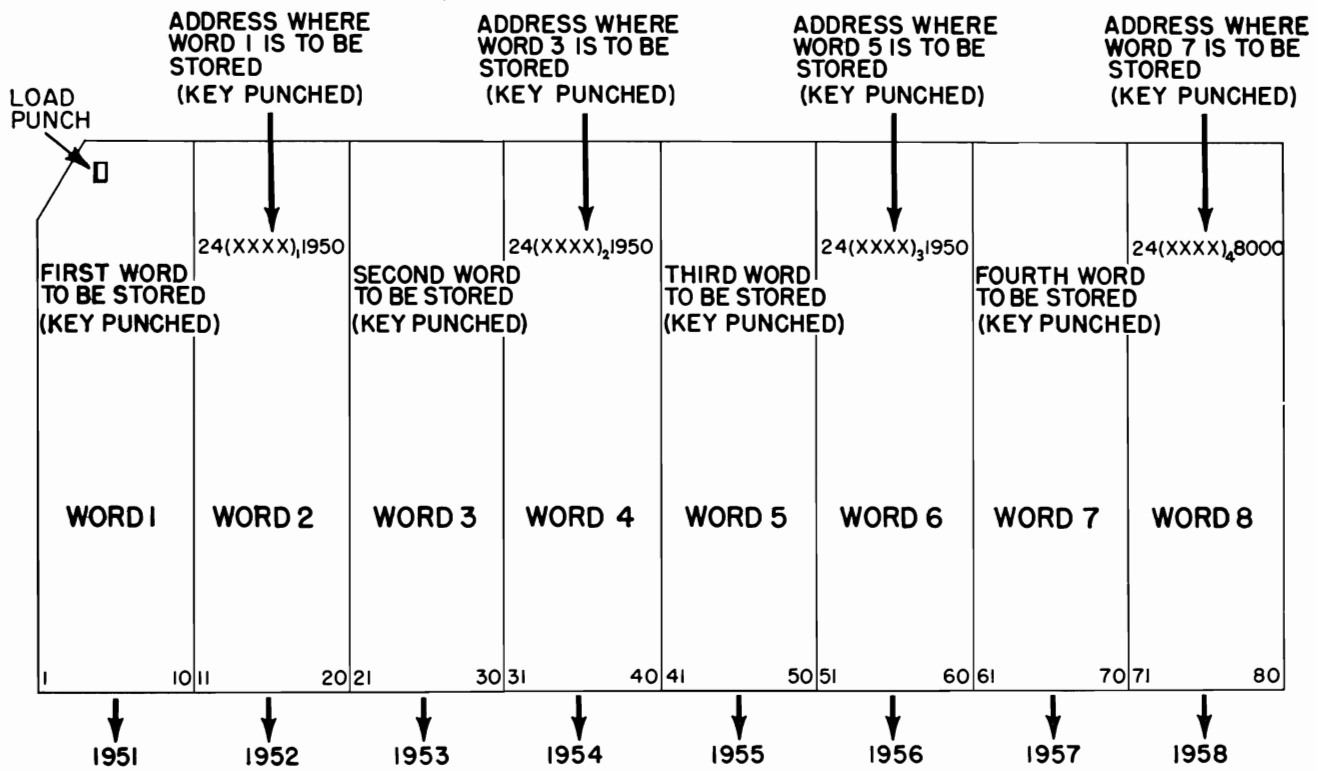

Figure II-5. Card for Four-Word-per-Card Routine

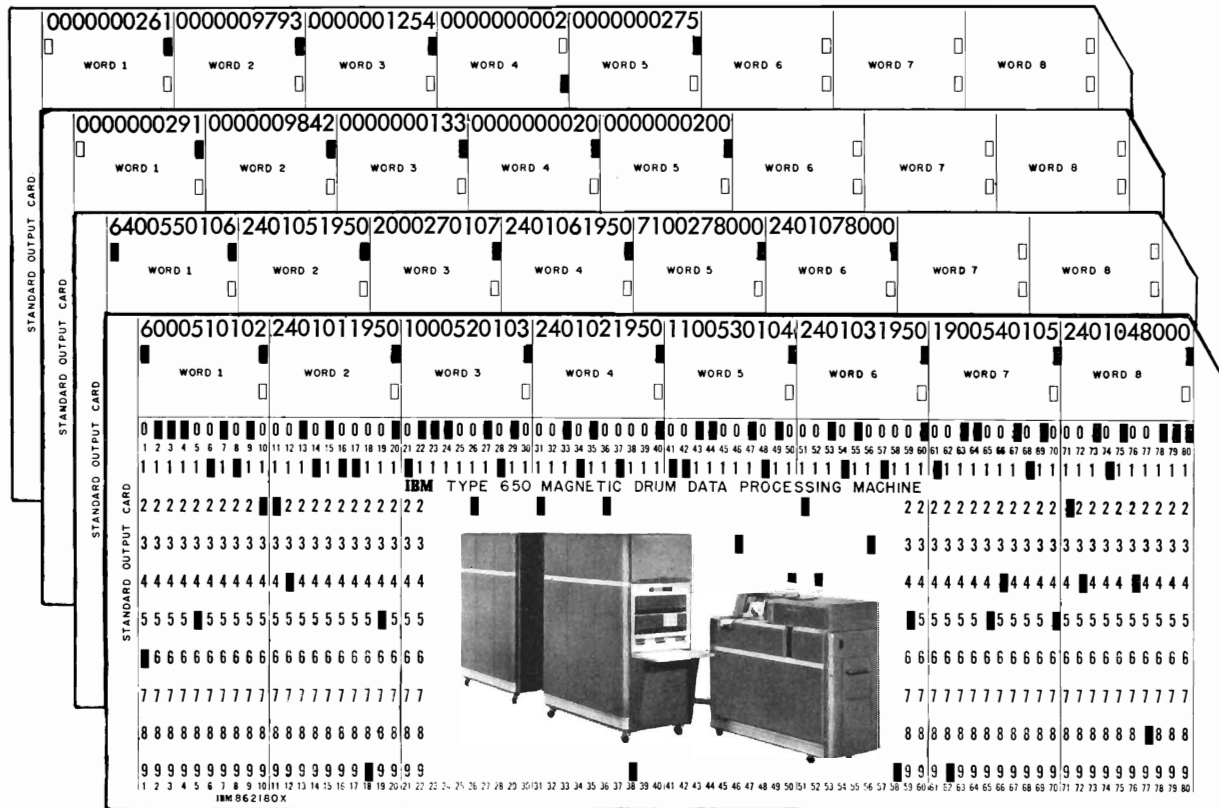

Figure II-6. Loading Cards for  $\frac{(A + B - C)D}{E}$

Thus, the machine automatically starts processing the problem upon completion of the loading routine.

If it is desired to stop the machine after loading before proceeding with the calculations, an address containing a pre-stored stop instruction (01 0000 0000) can be used as the I-address (XXXX) of the read instruction set in the switches. The machine can then be started by setting the starting address of the problem in the address selection switches and using the transfer key to transfer this address to the address register. The program start key will then start the calculator, which will take its first instruction from the location in the address register (0101).

An alternative method of starting the machine would be to set a NO-OP code in the storage-entry switches, with the starting address of the problem as its I-address (00 0000 0101). Set the control switch to the run position. Depress the computer reset key to reset the address register to 8000. Depress the program start key to start the calculator, which will then take its first instruction from the storage-entry switches. This instruction (00 0000 0101) will cause the machine to restart to I and take its next instruction from 0101, thus starting it on the sequence of the problem's program routine.

## BASIC ELECTRONIC CIRCUITS

THE BASIC functional electronic circuits used in the 650 are few and simple. The computing circuits are designed to employ twin triode tubes and germanium crystal diodes. In the computing circuits tubes are used functionally as inverters, double inverters, and cathode followers. Elsewhere in the machine, triodes are used as voltage amplifiers, shaping amplifiers, power units, and single-shot multivibrators. Thyatrons are employed in the read-out circuitry. Inverters and cathode followers are connected by external circuitry to form a *latch* circuit. Latches are used as a substitute for triggers where a momentary signal must be stored for later use and in timing ring circuits.

The logical circuits of the 650 make extensive use of germanium crystal diodes arranged to act as positive signal AND circuits and positive signal OR circuits.

Hereafter, to avoid confusion due to multiple usage of the terms AND and OR, AND circuits will be referred to as *switches* and OR circuits will be called *mixes*.

Crystal diodes are also used occasionally to clamp tube grid voltages at a fixed level.

Double-diode vacuum tubes (6AL5) are used in some circuits where applied voltages are too severe for crystal diodes or where the back resistance of a crystal diode is too low for proper back-circuit elimination.

Capacitor storage is used in the accumulator, distributor, and program register where rapid access to the stored information is essential. In the capacitor storage unit a capacitor and two associated vacuum diodes form a basic binary storage device, combinations of which are used to build up the one- or two-word storage unit.

## Inverters and Double Inverters

The basic characteristic of an inverter is implied in its name. A signal applied to its grid is reversed in polarity or inverted at the plate end of its load resistor (Figure II-7). The signal is usually also amplified in the process because of the tube's characteristics. The voltage levels, between which the inverter's output signal swings, are relatively high (typical values are plus 150 to plus 50 volts although lower amplitudes are often obtained by tapping the plate load resistor). The load resistance, across which the output signal is developed, is relatively high (typical value, 20K). Thus, the inverter is a high-impedance device whose output signal is rather easily distorted by associated circuit capacitance.

A double inverter is merely two coupled inverter stages where the plate output signal of the first drives the grid of the second. In a double inverter the signal is inverted twice so that the final output is of the same phase as the input signal. The coupling between stages may be direct or capacitive. If direct, the output signal has the same duration as the input. If capacitive, a pulse output signal is obtained even though the input may be of relatively long duration.

In the 650, inverters are largely used to restore the level of signals that have been altered by passage through diodes and cathode followers. The output signal of a double inverter is usually used to operate the

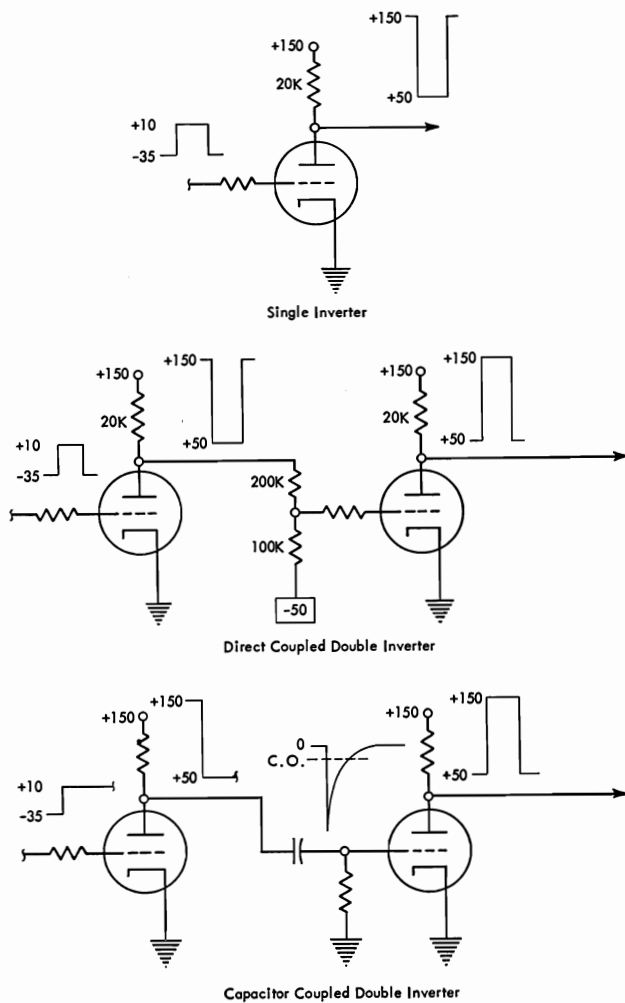

Figure II-7. Inverters

grid of a cathode follower whose output is a low-level, low-impedance, restored signal as in Figure II-8.

Inverters are sometimes used to block a signal that

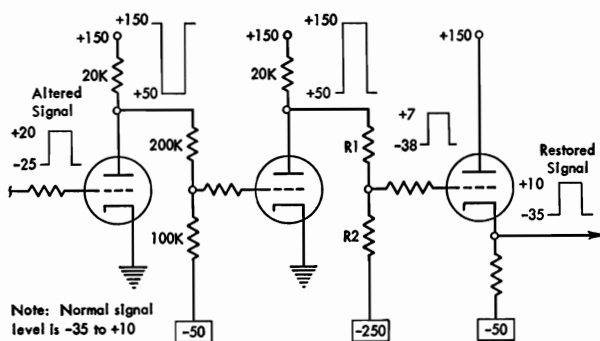

Figure II-8. Signal Level Restoration Using Double Inverter and Cathode Follower

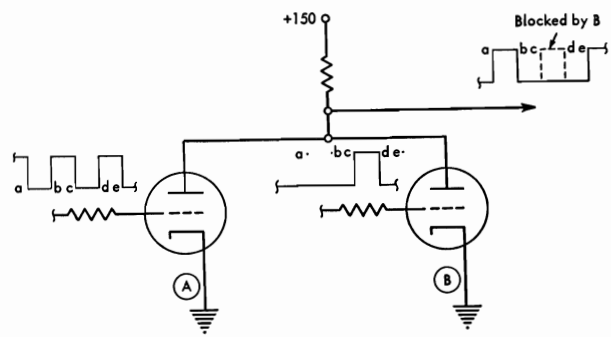

Figure II-9. Blocking Inverter

would otherwise be available. In Figure II-9 a positive output signal from tube A is periodically available except when tube B is caused to conduct through the common load resistor, thus holding the plate potential down and preventing tube A's plate voltage from rising to signal level.

### Cathode Followers

A cathode follower is a tube, usually a triode, with circuitry arranged so that the output signal is taken from the cathode end of a cathode load resistor (Figure II-10A). As its name suggests, the output signal follows or is in phase with the grid input signal. A cathode follower is inherently a negative feedback device, i.e., for values of grid voltage between cutoff and saturation, as the grid voltage is increased the cathode voltage also increases due to the increased IR drop across the cathode load resistor. The net result is a self-biasing action that limits the amplitude of the output signal to a value very nearly equal to the amplitude of the input signal. The amount of bias developed depends upon the tube characteristics and the load resistor value.

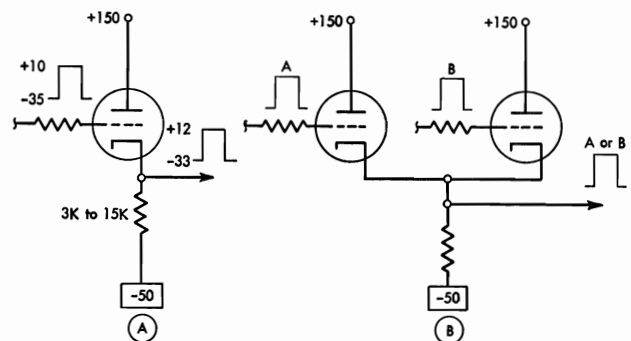

Figure II-10. Cathode Followers

In any case the cathode reaches an equilibrium potential more positive than the grid. Thus, a signal will gradually have its levels raised as it passes through a series of cathode followers. Cathode follower load resistors need not be as large as those used for inverters, because the value of the load resistor has less effect on the amplitude of the output signal. Thus, a cathode follower can be a relatively low impedance device whose output signal is less susceptible to distortion by associated circuit capacitance. In the 650 the voltage levels between which a cathode follower output signal swings are commonly of the order of minus 35 to plus 10 volts.

An important point to note in connection with cathode followers as used in the 650 is that, unlike inverters, the tube is always conducting whether the grid is at the no-signal level ( $-35$ ) or the signal level ( $+10$ ), because the cathode resistor is returned to a voltage value more negative than the no-signal level.

Cathode followers are frequently used with double inverters for dc signal-level restoration (Figure II-8). They are also often used to give a signal, whose levels are still usable, more drive after it has been attenuated by passage through a series of diodes.

Two cathode followers may share a common load resistor and thus form a logical OR circuit where either signal A or signal B will produce a similar output (Figure II-10B).

### Germanium Crystal Diode Switch and Mix Circuits

#### Diode AND Circuits

Germanium diodes are widely used in switching circuits in the 650. There are basically two types of switches, those requiring the presence of two or more signals to give an output and those requiring the presence of any one of several input signals to give an output. The first type is called a *switch* and the second type is referred to as a *mix*.

The diagram shown in Figure II-11 illustrates a diode switch circuit. Switches S1 and S2 are the inputs to the diodes, and the output is taken from the common plates of the diodes. The input signals can be either  $-35$  volts or  $+10$  volts.

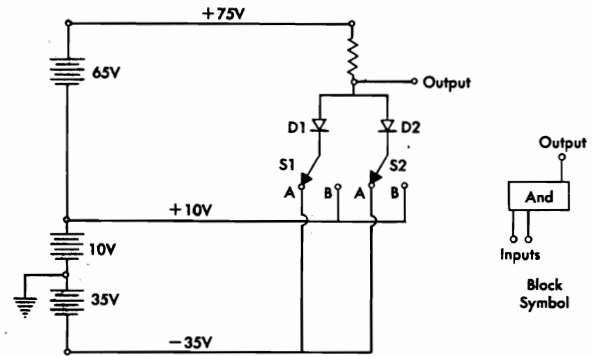

Figure II-11. Diode AND Circuit

With S1 and S2 set to position A as shown, the diodes are connected to  $-35$  volts. The output voltage will be effectively  $-35$  volts because of the low forward resistance of the diodes. Current can flow from the  $-35$ -volt level up through the diodes in parallel, through the load resistor and to the  $+75$ -volt potential. Practically all of the voltage drop will be across the load resistor so the output will be  $-35$  volts.

If S1 is now thrown to B, the potential across the D2 branch is the greatest. The output is still effectively connected to the  $-35$  volts through the low forward resistance of D2 so the output is  $-35$  volts. When S2 is also thrown to position B, both diodes are connected to  $+10$  volts, and the output will now be  $+10$  volts.

Notice from this it was necessary that both inputs be up to the  $+10$  volts level before the output could come up. Also note that the output is controlled by the branch of the circuit that has the greatest voltage drop across it.

This type of switch circuit may have from two to about five inputs.

#### Diode OR Circuit

Figure II-12 illustrates a diode mix circuit. With S1 and S2 set to A as shown, the output will be  $-35$  volts. In this condition the output is connected through the diodes in the forward direction to the  $-35$ -volt potential. The low resistance of the diodes is negligible compared to the load resistor, so that the output is effectively  $-35$  volts.

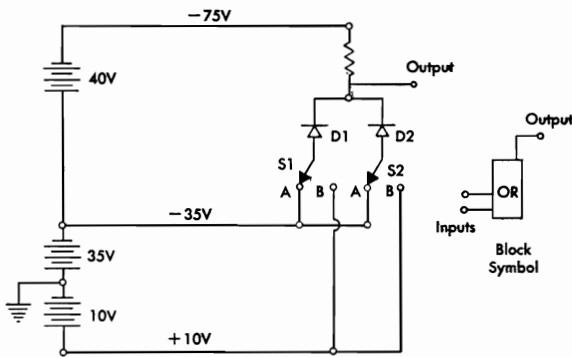

Figure II-12. Diode OR Circuit

If switch S1 is set to B, the output is now connected to +10 volts through the diode D1 in the forward direction. This caused the output to be effectively +10 volts. The same would be true if S2 had been set to B. Diode D2 would then connect the output to the +10-volt potential.

With this type of circuit, notice that either input going up to +10 volts causes the output to go up to +10 volts. In this circuit, as in the diode switch cir-

cuit, the output is determined by the branch of the circuit that has the greatest voltage drop across it.

The diode mix is used when one of the several input signals is to control a given function. The mix prevents any back circuit or interaction between input signals. One mix may have from two to nine inputs.

Some typical connections using diodes to form switch circuits, mix circuits, and combination switch and mix circuits are shown in Figure II-13. Consider the switch circuit. Assume that the A signal is -35 volts and the B signal is +10 volts. The source impedance of signal A in series with the forward resistance of the diode is sufficiently low in comparison to the resistance R to hold point X at a minus potential. The back resistance of the other diode is high enough to prevent the plus B signal from raising the potential at point X. Thus, point X will rise to a plus potential only when both signals A and B are at plus potential.

In the mix circuit a plus B signal will raise point X to about the signal potential (plus 10 volts) because the combined diode forward resistance and the signal B source impedance is small in comparison to resistance R. The minus A signal has no effect on the

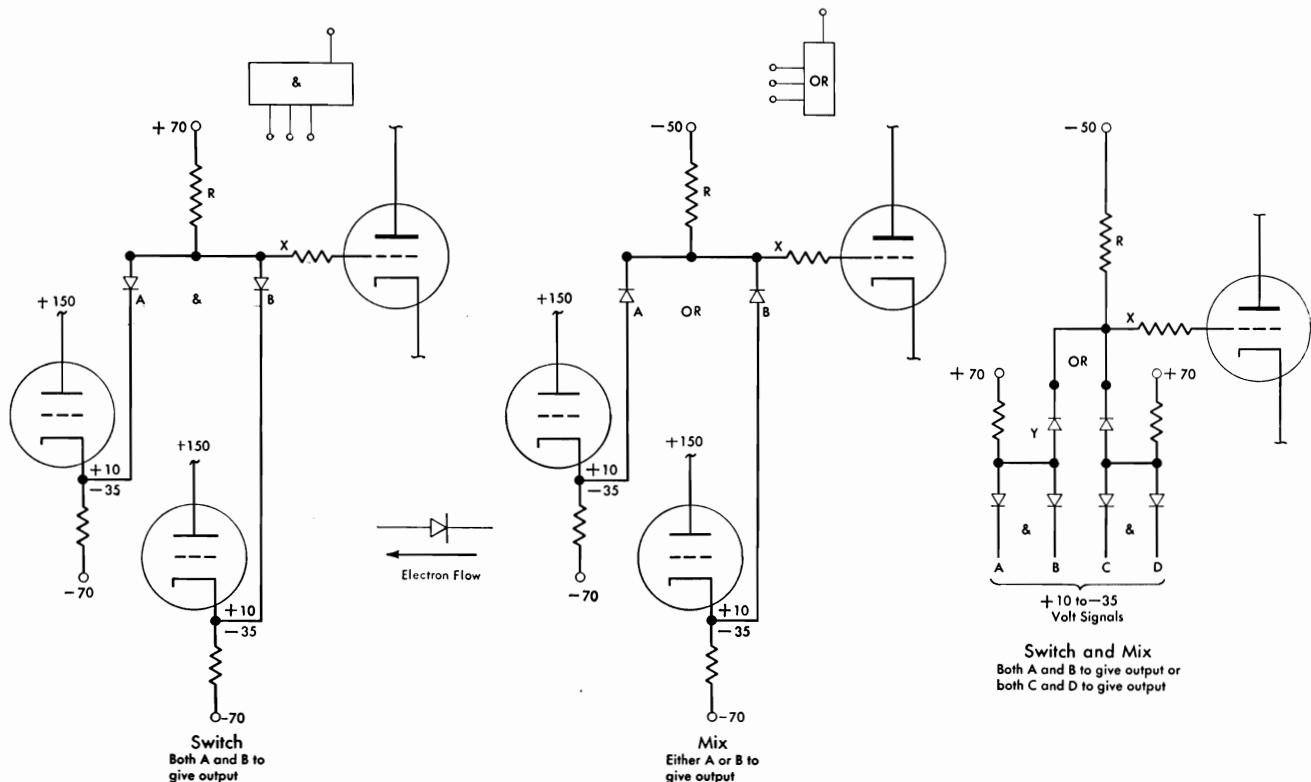

Figure II-13. Crystal Diode Switch and Mix Circuits



potential at point X, because its diode back resistance is high and provides a means of dropping the potential difference that exists between the two signals. Under these conditions either the plus A or the plus B signal will raise the potential of point X.

In either the switch or the mix circuits, notice that the potential of the output point (X) is determined by that branch of the switch or mix that has the larger potential across it when both are not the same. For example, in the switch circuit of Figure II-13, when the voltage across R and A is 60 volts and that across R and B is 105 volts, the potential at X is determined by the R and B branch.

In the combination switch and mix circuit, plus A and plus B signals raise the potential at point Y and through the mixing diode, point X is raised to a plus potential. Signals C and D will accomplish the same result. Thus, either A and B, or C and D will provide an output signal at point X.

**Diodes Used for Restoration of DC Levels**

Crystal diodes are also used for clamping, and clipping in several places in the 650 circuits. Figure II-14 shows two typical diode clamping circuits. In Figure II-14A a cathode follower is shown where the grid is at -50 volts under no-signal conditions. The cathode is returned to -70 volts. The tube has reached a no-signal equilibrium status and is conducting with -5 volts of self bias. Thus, the no-signal output level is -45 volts. The grid has a capacitor input, and it can be seen from the values of the components that the time constant is about 6 microseconds ( $39\text{mmf} \times .15 \text{ megohms}$ ).

When an 8 microsecond, 45-volt signal is applied as shown, the grid immediately rises by 45 volts from -50 to -5 volts with a corresponding change in the output. Because the time constant is less than the duration of the applied signal, the capacitor charges, allowing the grid to return to almost -50 volts along the exponential capacitor charge curve, while the signal is still applied. At the end of the signal impulse, the negative 45 volts excursion of the trailing edge is reflected through the capacitor and would drive the grid to -95 volts except that the clamping diode shunts the 150K resistor and provides a low-resistance path for almost instantaneous charging of the capacitor, when its grid end tries to drop below -50 volts.

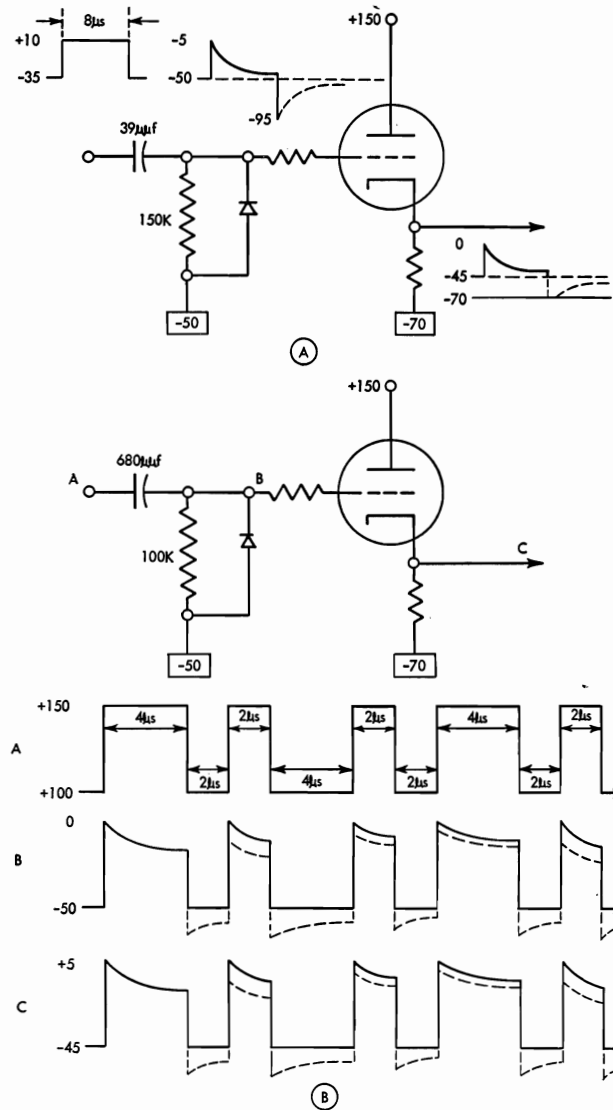

Figure II-14. Crystal Diodes Used for Clamping

This results in a clamping action that will not allow the grid to drop below -50 volts and eliminates the grid response pictured by the dotted lines of Figure II-14A.

Figure II-14B shows a similar circuit except that the input time constant (68 microseconds) is much larger than the duration of any of the signal impulses, so that the output signal will be essentially a square impulse. Here, the duty cycle of the train of signal impulses is irregular and varying intervals of time elapse between successive positive impulses. Again, as in Figure II-14A, the negative trailing edge of each impulse would tend to drive the grid below the normal -50-volt level.

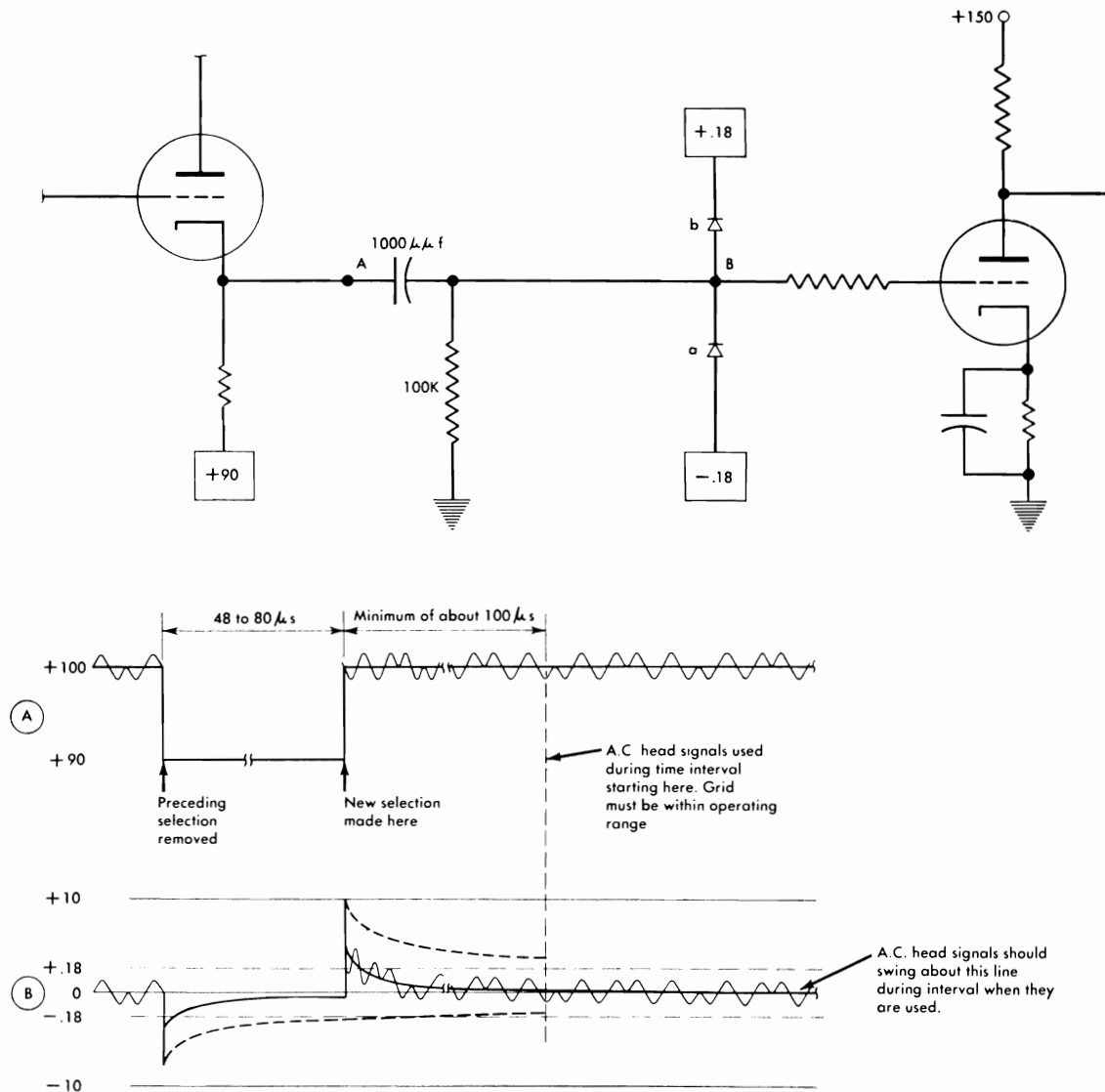

Figure II-15. Crystal Diodes Used for Clipping

Because of the varying duty cycle it is never known exactly how long the circuit has to recover from the results of the negative excursion before the arrival of the next positive impulse, and in any event, insufficient time would be available because of the long time constant. Thus, the clamp diode holds the grid up to  $-50$  volts and eliminates the situation pictured by the dotted lines. Note that except for the action of the clamp diode, because of the irregular duty cycle, the potential of the grid (point B) would vary and would be at a different level at the time of each new positive impulse. This would result in varying levels of output signal as shown by the dotted lines of Figure II-14B.

Figure II-15 illustrates diodes used for rapid restoration of a grid voltage level to a predetermined operating range. This is an action similar to clipping except that the time constants involved are sufficiently long to allow a leading edge spike to appear, so that the entire signal is not clipped. The circuit shown is the input to a read head signal voltage amplifier. The amplifier is operated class A, with a bias resistor in the cathode circuit. The head signals that are to be amplified are sinusoidal in form and are of the order of 160-270 millivolts, peak to peak.

Because there are several groups of heads across the drum, on any read operation, one group must be

selected whose signals are to be amplified. This selection, which occurs anywhere from several milliseconds to a minimum of about 100 microseconds before the head signals are to be used, results in a shift of about 10 volts at the input to the amplifier. The circuit must have recovered from the effect of this shift before the time arrives when the ac head signals are to be used, so that the signals will swing about a zero dc level within the range of plus or minus 180 millivolts. This is necessary for proper operation of the circuits following the amplifier. The waveforms at Point A and B are shown. The dotted lines of B show what the dc grid level would be without the diodes, if recovery depended solely upon the time constant of the capacitor and resistor ( $1000 \text{ mmf} \times .1 \text{ megohms} = 100 \text{ microseconds}$ ).

With the diodes in the circuit, whenever the voltage at B is forced above or below plus or minus 180 millivolts, one or the other of the diodes conducts and effectively shunts the resistor, thus reducing the time constant to  $1000 \text{ mmf} \times$  the forward resistance of the conducting diode plus impedance of signal source, and thereby greatly reducing the time required for point B to recover to a level within the necessary limits. The diode forward resistance is of the order of 200 ohms. The same impedance on a positive swing is the effective internal resistance of the conducting cathode follower, also of the order of 200 ohms. Thus the time constant while diode B is conducting on a positive swing is about  $.001 \text{ mf} \times (200 \text{ plus } 200 \text{ ohms})$  or .4 microsecond, resulting in the short positive spike at B.

The source impedance on a negative swing is practically zero, because the 10-volt negative shift was produced by cutting off the cathode follower, providing very little effective resistance in the charge path of the capacitor. Thus, the time constant while diode A is conducting on a negative swing is about  $.001 \text{ mf} \times 200 \text{ ohms}$  or .2 microsecond, resulting in the somewhat shorter negative spike at point B.

### Vacuum Diode Switching Circuits

On machines manufactured after February, 1956, there are switching circuits using vacuum diodes. These diodes are used in switch circuits and in combination switch and mix circuits.

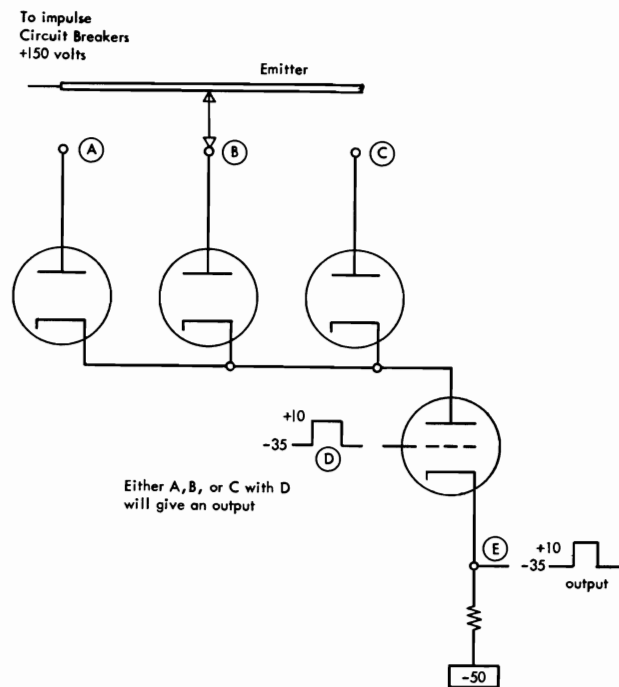

Figure II-16. Basic Electronic Circuit—Vacuum Diode Mix

Figure II-16 shows a typical circuit that is a form of vacuum diode mix. In this circuit it is necessary to have plate voltage on one of the diodes and have a positive gate input to the cathode follower. With the emitter making contact at point B, as shown, there is a path for current flow from  $-50$  volts through the cathode follower and up through the diode to the emitter at B and to the  $+150$ -volt line. This circuit supplies plate voltage to the cathode follower so that when an impulse or gate is received at D the cathode follower will conduct more and cause the output of the cathode follower at E to go up. In this circuit it is necessary to have either A, B, or C, with D in order to give an output at E.

Figure II-17 shows a switch circuit using a vacuum diode. In this circuit it is necessary to have both inputs A and B up in order to get an output from C.

With a gate at A the output of the cathode follower is up to  $+10$  volts. There can be no conduction through the diode. Point C is held down by the action of the lower cathode follower through the  $33\text{K}$  resistor.

With the impulse applied at B the lower cathode follower output will come up and therefore bring up

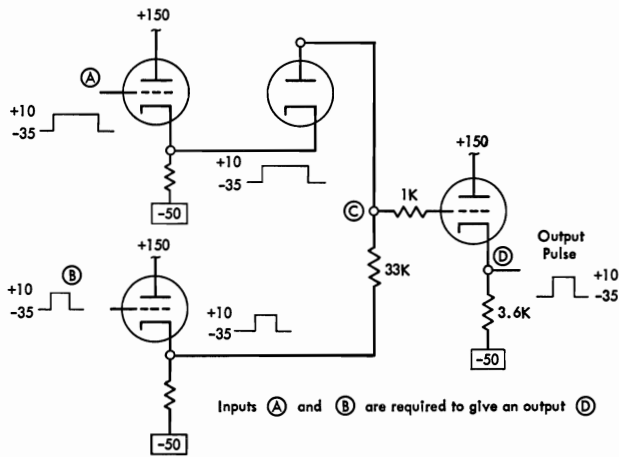

Figure II-17. Vacuum Diode Switch

point C so that the output cathode follower will conduct. Note from this that the output signal is available only during the coincidence of signals A and B.

Figure II-18 shows a combination switch-mix using vacuum diodes. In this circuit tube 3 and tube 4 act as a switch with tube 5 and tube 6 being the mix.

With tubes 1 and 2 in their normal state the diodes 3 and 4 hold the plate of tube 5, point C, down to about  $-35$  volts. When a gate is applied at point A,

the output of tube 2 goes up, but point C remains down because of the conduction of tube 3.

When an impulse is applied to point B, tube 1 goes into full conduction, its output goes up to  $+10$  volts and point C goes up to  $+10$  volts. With point C up, tube 5 conducts and brings point D up to the  $+10$  level. This is the input signal to the latch, turning the latch ON and giving a positive output. This positive output holds the input up through the conduction of tube 6. The latch will remain ON until it is turned off by a positive OFF pulse.

### Latch Circuits

In most electronic computers the timing, counting, computing, conversion, and input-output circuits utilize some type of flip-flop device having two stable states. In the past this device has been a multivibrator type of unit commonly called a trigger. In the 650 a newer device called a latch circuit is used. This circuit has two primary advantages over the trigger.

First, it is not a balanced circuit, and as a result, tube balance and matched components are not of prime importance. The latch will continue to function properly under conditions that would cause erratic operation of a trigger.

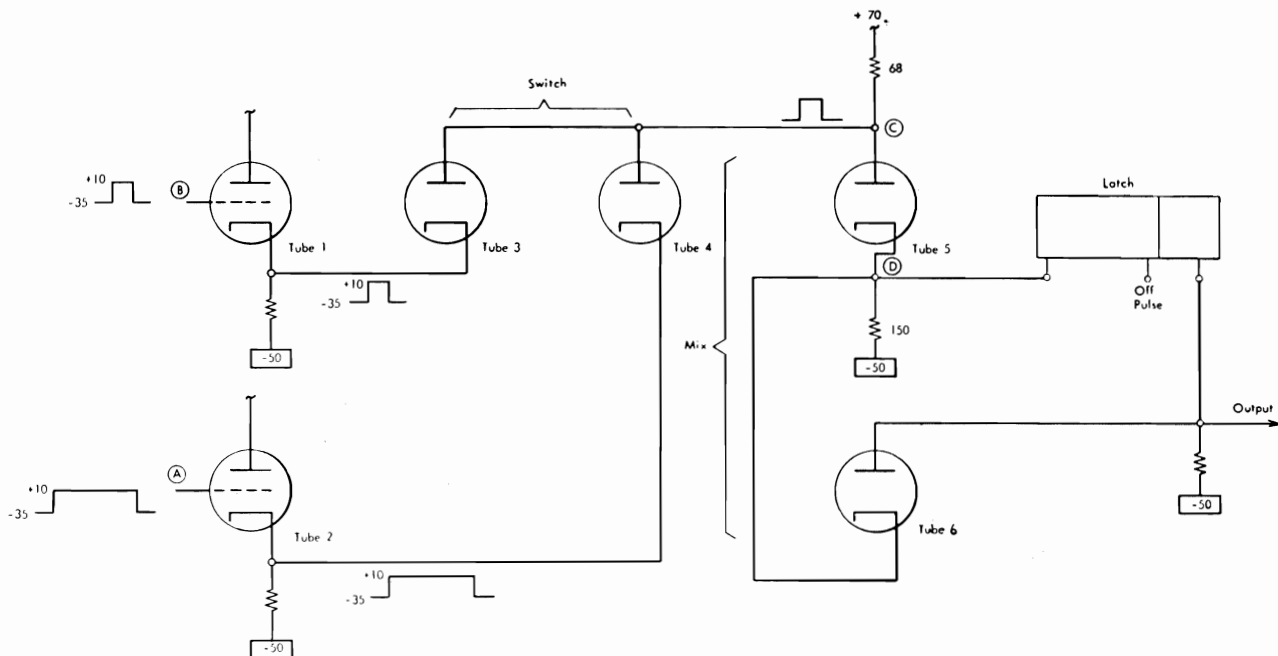

Figure II-18. Vacuum Diode Switch and Mix

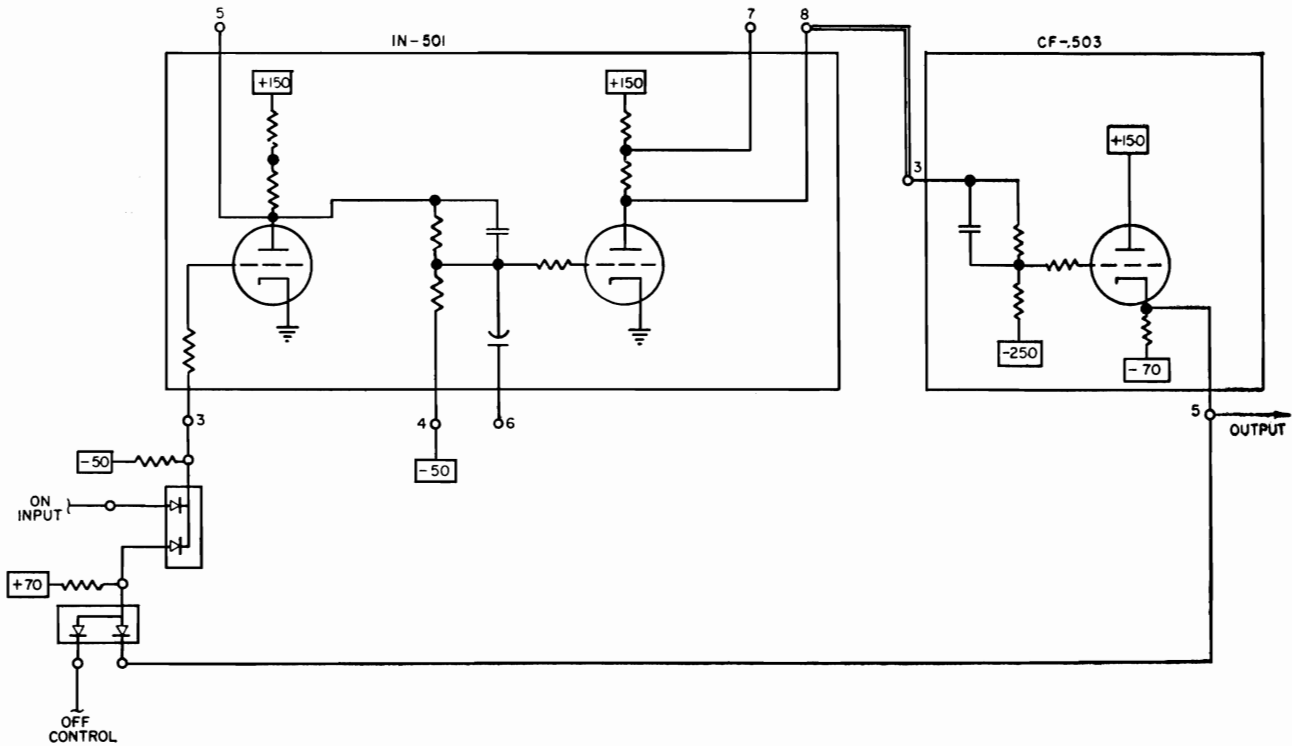

Figure II-19. Latch Circuit

Second, a latch is comprised of a double inverter and cathode follower, usually with a diode switch or mix input to the latch circuits. This permits standardizing on fewer types of pluggable units. When triggers are used, several different types are required. A latch is merely put together from existing inverter, cathode follower, and diode units.

Figure II-19 shows a latch circuit with a diode mix input. An input pulse will raise the grid of the first triode inverter above cutoff, causing the triode to conduct. This in turn lowers the grid potential of the second inverter below its cutoff point. The plate voltage rise of the second inverter in the non-conducting state causes the grid of the cathode follower to rise to a conducting potential. As a result the cathode follower output rises to about a + 10-volt potential.

This output is available for use, to act on some further circuit, and is fed back to the grid of the first inverter through the switch and mix diode circuitry to hold it at a conducting potential. This positive feedback is sufficient to hold the circuit in the latched condition. This ON condition will sustain itself until some external action is applied to the circuit to render

the output cathode follower non-conductive. The most common method of turning a latch off is by lowering the signal on the latch back diode switch labeled OFF control.

When this signal goes down there is no longer a feed-back signal to keep the first inverter in a conducting status. Its plate voltage rises, causing the second grid to rise and throwing the second inverter into conduction. When this happens, its plate voltage goes down, thus forcing the output cathode follower signal to go down, thereby turning the latch off.

Another method of turning the latch off is to put in a positive signal to the second grid, pin 6. This causes the second inverter to go into conduction, bringing its plate voltage down, thus forcing the cathode follower output down.

When the latch is OFF it may be turned ON by a negative pulse applied to the second grid, pin 6. This negative pulse will turn the second inverter off, cause its plate voltage to go up, the cathode follower output to go up, and feed back to the grid of the first inverter and hold the latch ON.

The latch may also be turned on by clamping the

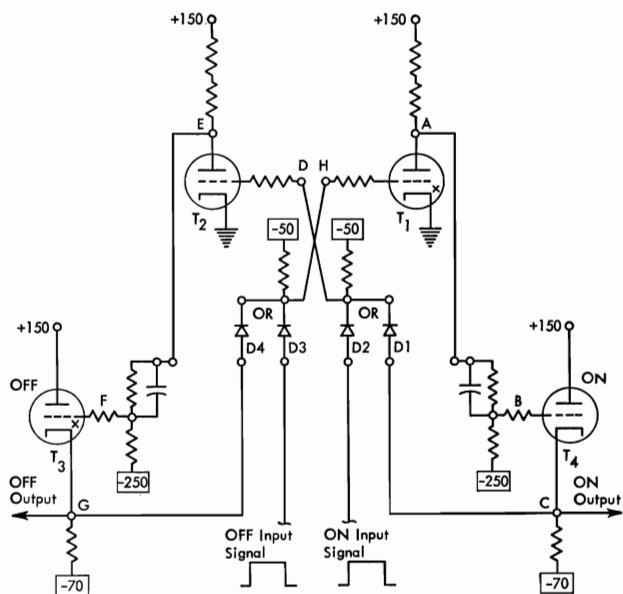

Figure II-20. Double Latch Circuit

plate of the first inverter with another triode. This tube shares the same load resistor as the first inverter so that, when it conducts, the plate of the first inverter goes down and thus causes the latch to turn ON.

In a similar manner the latch may be turned OFF by clamping the plate of the second inverter down with another triode. When the plate of the second inverter is pulled down, the cathode follower output goes down and the latch is turned OFF.

It is also possible to reset the latch by connecting pin 4 to a reset line. If this reset line is allowed to go up, the bias will be removed from the second inverter, and it will go into conduction. When it conducts, its plate voltage goes down, the cathode follower output goes down, and the latch is reset OFF. This reset may be either automatic or controlled manually.

Figure II-20 shows a double latch circuit. This circuit is frequently used where the extra safety and checking action of a positive OFF signal is desirable. This circuit is comprised of two single inverters, two cathode followers with divider grid inputs and two diode mix circuits. Input variations can be obtained by using switch-mix diode circuitry instead of simple mixes as shown.

Initial circuit conditions, assuming the latch to be OFF are as follows:

1. T1 conducting
2. A at low potential
3. B at no-signal level
4. C at no-signal level (-35)
5. D below cutoff potential through mix diode D1
6. E at high potential
7. F at signal level (+10)
8. G at signal level (+10)
9. H at conducting potential through mix diode D4 holds T1 conducting.

When an ON input signal is applied to D through mix diode D2, the circuit is transferred to an opposite set of conditions. T2 conducts, lowering the output of T3, which drops H below cutoff potential. A rises and T4 conducts, raising C, which holds D up through mix diode D1. The latch has been turned on and remains in this condition until an OFF input signal restores it to the initial state.

### Latch Ring

For timing and synchronizing purposes it is necessary to generate timed pulses and gates. These are used to establish the basic machine cycles and controlling gate voltages. A ring type of circuit is used to develop some of these timing gates. The latch circuit previously described is easily adapted for use in a ring circuit. Figure II-21 illustrates a 10-point ring where the first two stages and the last stage are shown together with a theoretical timing chart showing the relationship of input, output, and transfer pulses. The input pulse source is a cathode follower drive from a basic timing source such as permanently recorded spots on the drum timing tracks. The negative input pulses are about two microseconds in duration with an amplitude of 45 volts ranging from -35 volts to +10 volts. The cathode follower output gates have a duration equal to the time interval between the driving pulses with a swing of about -40 to +10 volts.

Assume that only stage 1 is on and thus the 1 output is at +10 volts. This condition exists at time  $t_0$  of the timing chart. The +10-volt 1 output signal through diode  $Y_1$  of the diode switch in coincidence with the +10-volt input signal through diode  $X_1$  of the same switch, holds the grid of the first inverter of stage 1 at conducting potential. This estab-

Start with

Develops sites

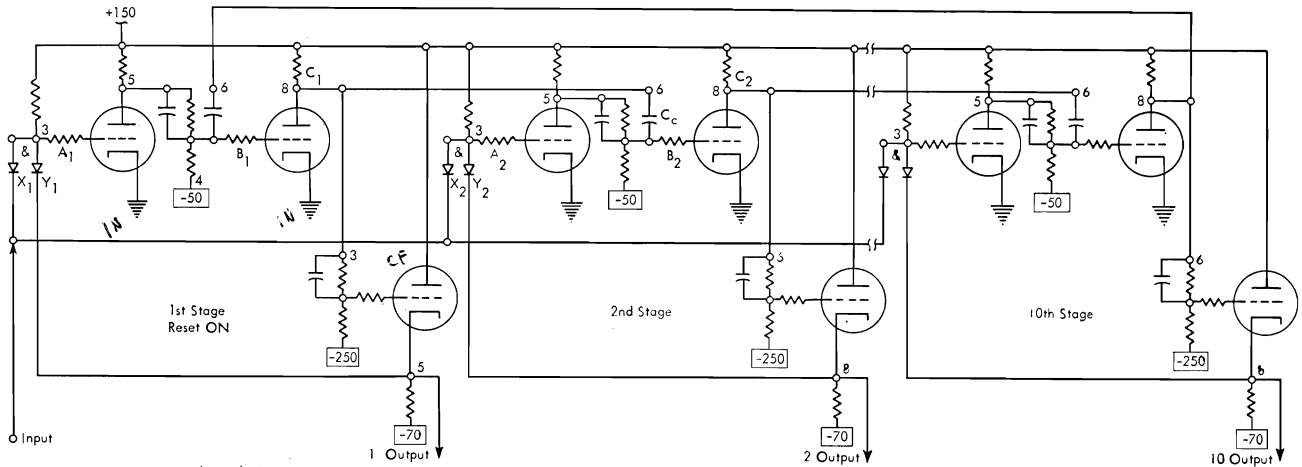

Control

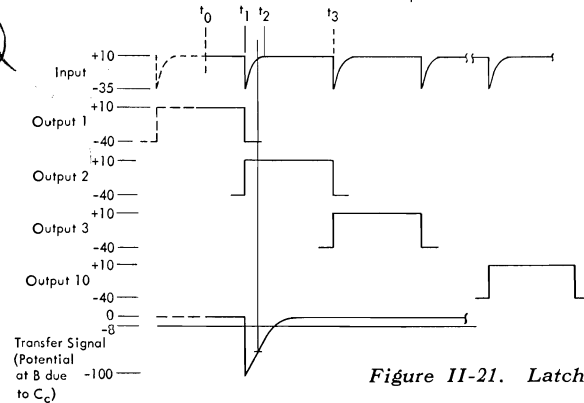

Figure II-21. Latch Ring

lishes a stable ON or LATCHED condition for the first stage latch, which will be maintained until a lack of coincidence occurs at the  $X_1 - Y_1$  diode switch. At  $t_1$  the input signal level drops to  $-35$  volts. There is no longer a coincidence of plus signals at switch  $X_1 - Y_1$ ; and grid  $A_1$  drops to cutoff potential. As a result, grid  $B_1$  is raised to conducting potential, and anode  $C_1$  is lowered owing to the conduction of the second triode. When the potential of Point  $C_1$  drops, the stage 1 cathode follower grid is lowered, and its output drops to a  $-40$  volts. The drop in potential at  $C_1$  is capacitor-coupled to point  $B_2$ , the grid of the second inverter of the second stage, causing it to cut off. The potential at  $C_2$ , the anode of the second inverter rises sharply causing the second stage cathode follower output to rise to a  $+10$ -volt level. The size of the coupling capacitor  $C_c$  is sufficiently large to hold  $B_2$  below cutoff for at least 2 microseconds.

In the meantime, the input signal has returned to  $+10$  volts ( $t_2$ ), and there is now a coincidence of  $+10$ -volt signals at switch  $X_2 - Y_2$ , which raises grid A to conducting potential. Hereafter grid  $B_2$  will be

held at cutoff potential by the conduction of the first inverter and need no longer rely on the transfer signal through  $C_c$ . At  $t_2$  a stable condition is reached with the stage 2 latch ON and the transfer from the first latch to the second has been completed.

Note that the transfer was instantaneous, within circuit limitations due to stray capacitance, because the 2 output was energized through  $C_c$  at the same time the 1 output was de-energized. The transfer pulse across  $C_c$  was sufficiently long to bridge the gap from  $t_1$  to  $t_2$  and allow stage 2 to LATCH at  $t_2$ . At  $t_3$  the process is repeated, stage 2 unlatches, and stage 3 latches.

Figure II-22 shows the composite oscillographs of the transfer wave forms.

### Voltage Amplifiers

In the 650, class A voltage amplifier circuits are used to amplify the sinusoidal head signals before they are used. Figure II-23 shows a typical voltage amplifier circuit used in connection with the buffer storage read circuits. The circuit is a straightforward, two-stage, class A amplifier with direct coupling to the first stage and capacitor coupling to the second. The output is an amplified replica of the input signal.

### Shaping Amplifiers

In the 650 magnetic-storage read circuitry, the voltage amplifier outputs are applied to a special type of circuit called a shaping amplifier. The main function of the shaping amplifier is to alter the shape

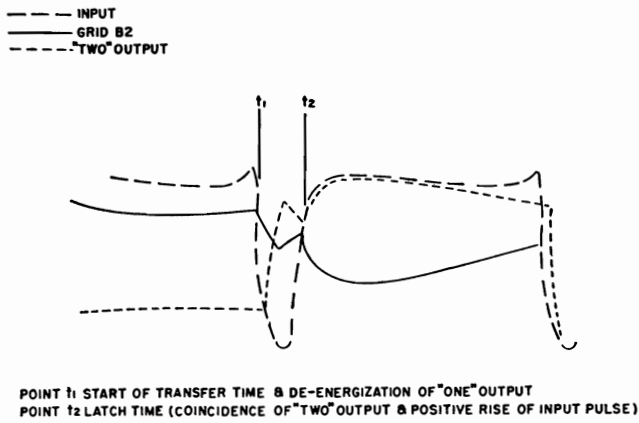

Figure II-22. Oscillographs of Latch Ring Transfer

of the voltage amplified, sinusoidal head signal, so that it more nearly approaches a square pulse and is thus better suited for use as an input to a diode switch.

SA 501

Figure II-24 shows a shaping amplifier circuit and the input and output wave forms. A sinusoidal head signal of about 25 volts peak to peak is applied to point A. The diode in the grid circuit prevents the amplifier from responding to a negative swing of the

signal. On positive excursions of the head signal, the grid voltage swings positive and would increase by the full 25 volts of the applied signal except that it is clipped to a 10-volt value by the flow of grid current.

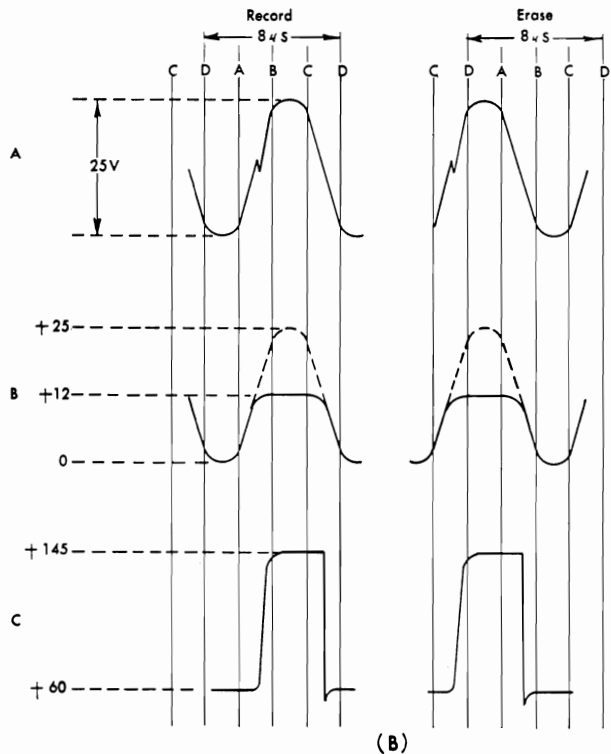
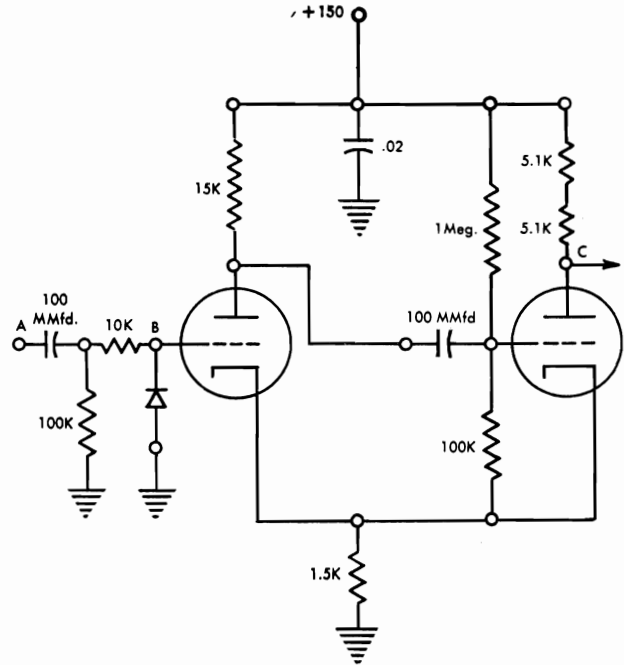

Figure II-24. Shaping Amplifier SA 501

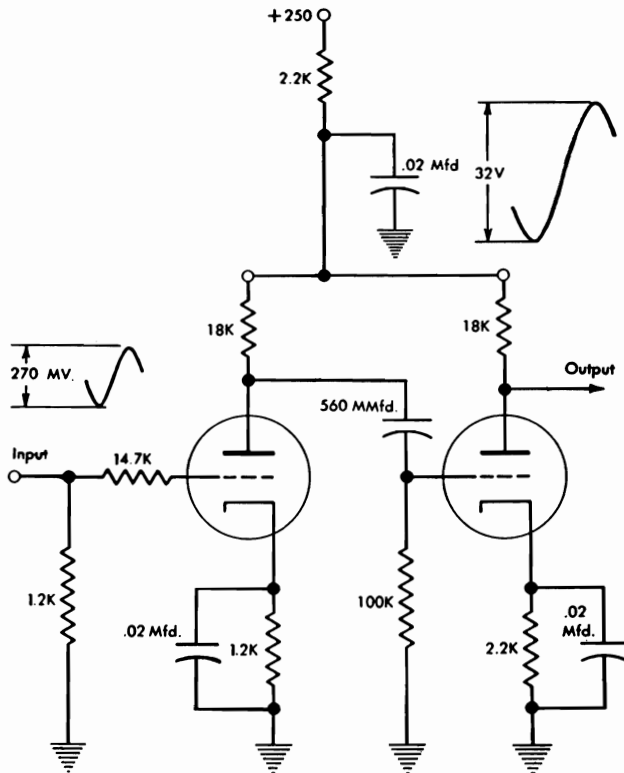

Figure II-23. Voltage Amplifier



This clipping is shown by the dotted lines of the curves for point B. The output of the first stage is capacitor-coupled to the second stage, the output of which is shown by the curves for point C.

Thus, whenever the head signal swings in a positive direction, the shaping amplifier responds with a reasonably square pulse that is in phase with the positive signal swing.

SA 506

Figure II-25 shows the input and the output wave forms and the shaping amplifier circuit used in general storage. The amplified head signal of about 25 volts peak to peak is applied to point A. Grid bias for T1 is developed across R1 on the negative swing of the input signal and holds T1 cut off. On the next positive swing of the input signal, T1 will conduct when the grid rises above cutoff. The grid rises to ground potential and is clamped at ground by the diode action of the grid and cathode as shown for point B. Wave form C shows the output of the first stage. This is inverted by the second stage to produce a positive square wave on each positive swing of the

head signal (Wave form D). As the amount of grid bias of T1 is determined by the input signal, smaller head signals have less bias to overcome. Larger head signals must overcome a higher bias. This permits correct operation over a wider range of head signal amplitudes.

Power Units

A number of units are used in the 650 that are called power units. In general a power unit is basically either a cathode follower or an inverter using a tube type designed to deliver more power to the circuits that it drives.

One rather special type of power unit (PW502) is found in the magnetic-storage writing circuits. It is a two-stage unit consisting of an inverter, with a plate peaking inductor, and capacitor-coupled output cathode follower. The purpose of this unit is to develop an extremely sharp, short-duration signal for controlling the tube which impulses the write coils so that a short, sharp impulse of write current will be forced through the coil whenever a magnetic spot is to be placed on the drum surface.

Figure II-26 illustrates some typical power units found in the 650.

Figure II-27 illustrates the circuit and wave forms of the PW502 peaking power unit. In operation this unit is normally cut off and is pulsed by a two-microsecond pulse as shown at A. This positive pulse causes T<sub>1</sub> to go into conduction, and the voltage at point B drops as shown by the curves. As current starts to flow through the peaking coil, the voltage at B rises along a time constant curve. At the end of the two-microsecond pulse, T<sub>1</sub> is cut off. This stops current flow and induces a large back emf in the peaking coil. This induced emf attempts to keep current flowing so that its potential is positive at point B. This accounts for the high positive spike of voltage at point B. This same wave shape is carried through the capacity-coupled cathode follower. It is this short-duration voltage spike that is used to operate the power unit that causes current to flow through the magnetic head to write on the drum.

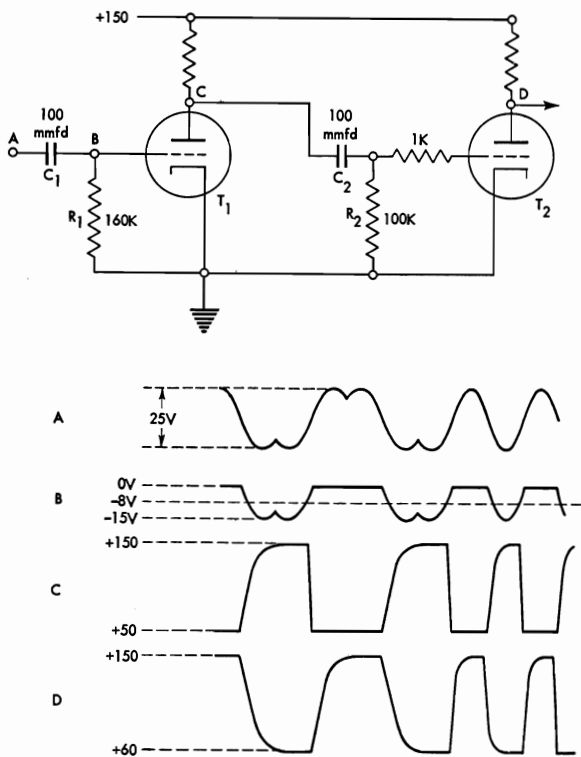

Figure II-25. Shaping Amplifier SA 506

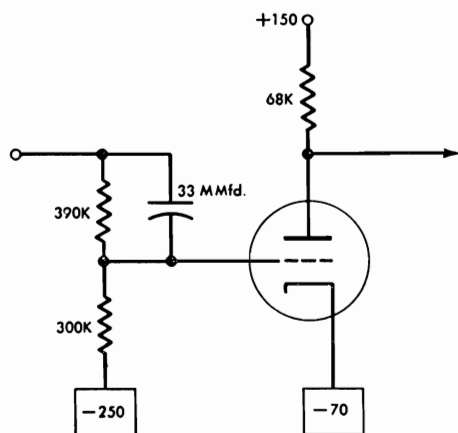
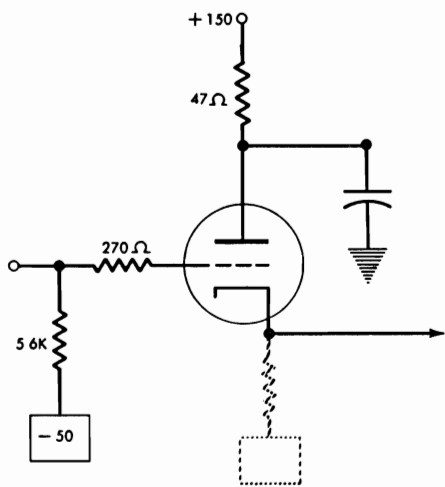
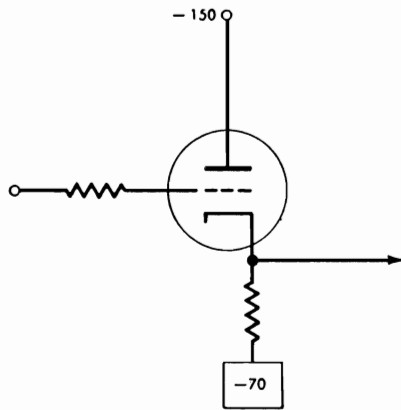
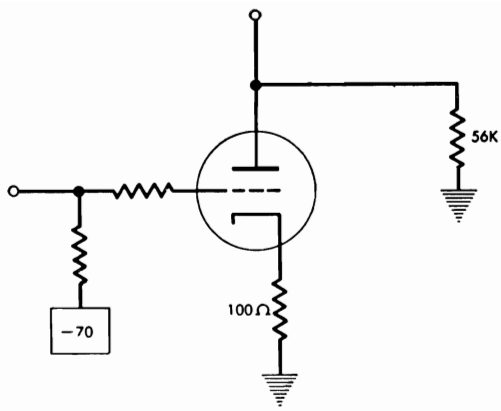

Figure II-26. Power Units

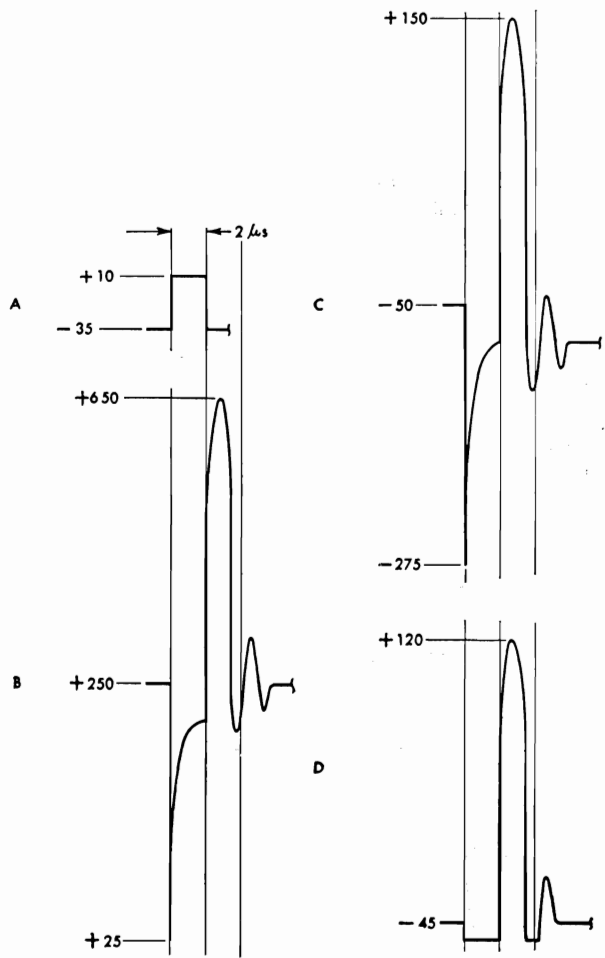
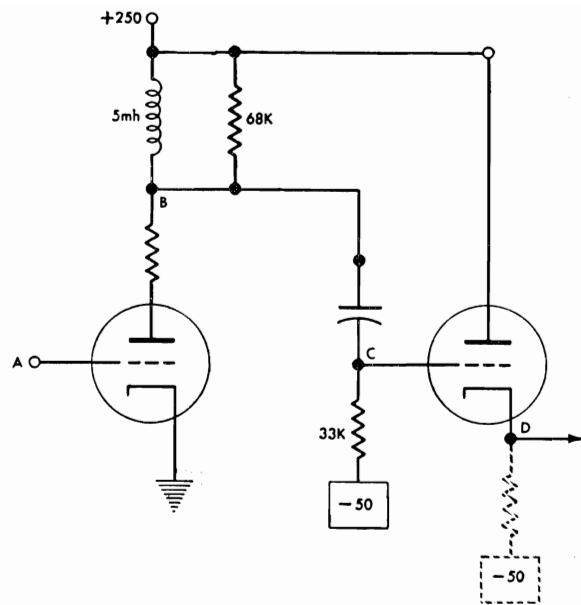

Figure II-27. Special Power Unit

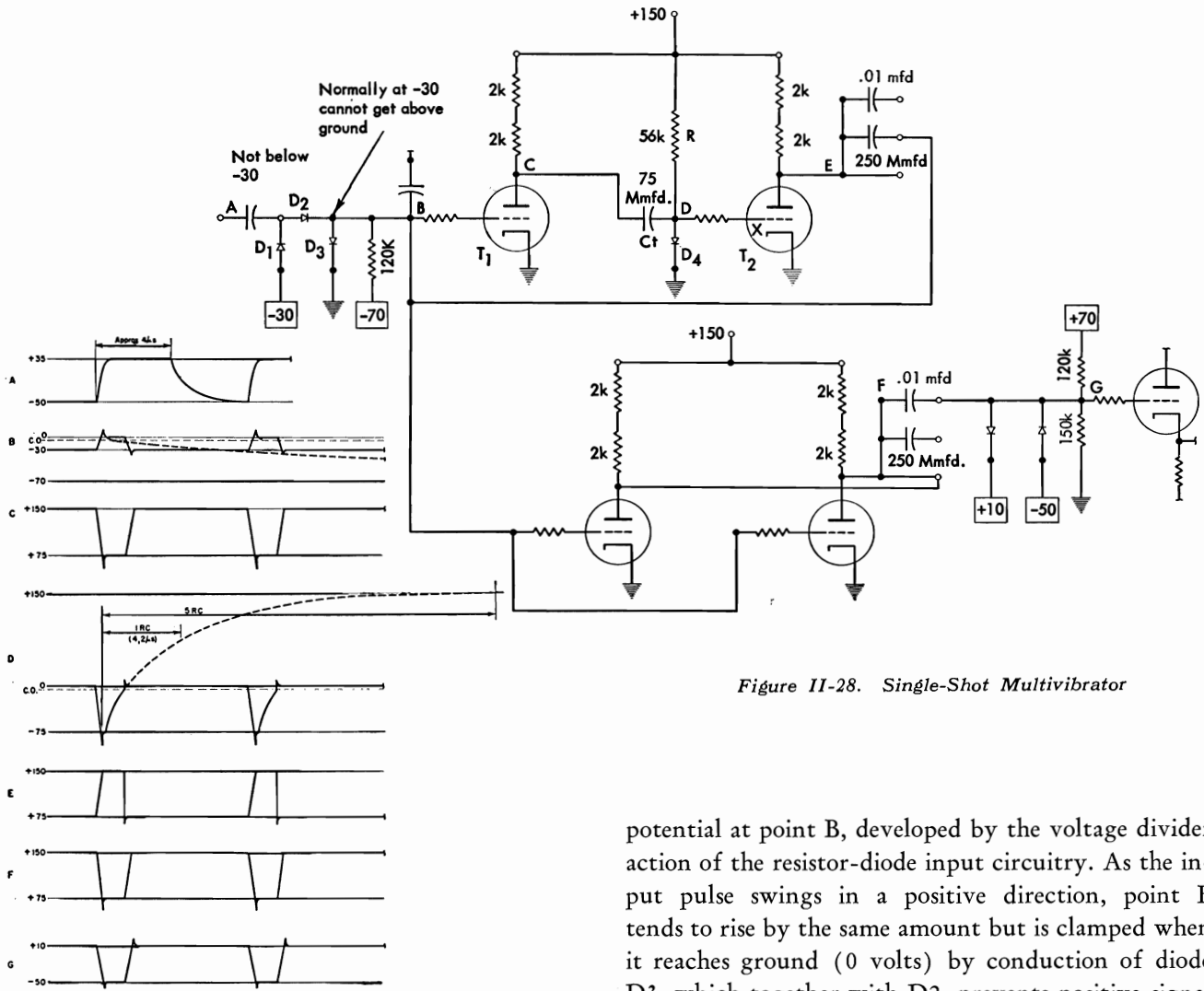

Figure II-28. Single-Shot Multivibrator

### Single-Shot Multivibrators

Several single-shot multivibrators are used in the circuits for the development of constant-width square timing pulses from the sinusoidal-shaped signals obtained from the timing tracks. These units are built up by external circuitry applied to a basic PW504.

A typical single-shot multivibrator circuit is shown in Figure II-28, together with the wave forms at various points of the circuit. The input pulse is the cathode follower modified output of a shaping amplifier, part of the read circuitry associated with the heads, which read the permanently recorded spots of the timing tracks.

In this circuit the right-hand tube is normally conducting as indicated by the X in the tube schematic. The left-hand tube is held cutoff by the -30-volt

potential at point B, developed by the voltage divider action of the resistor-diode input circuitry. As the input pulse swings in a positive direction, point B tends to rise by the same amount but is clamped when it reaches ground (0 volts) by conduction of diode D3, which together with D2, prevents positive signal voltage variations from influencing the multivibrator during its ON time. This rise of point B causes T<sub>1</sub> to conduct with the consequent drop in plate voltage as shown by the curves for point C. This negative voltage shift cuts off T<sub>2</sub>, through the capacitor C<sub>t</sub>, which together with R governs the ON time of the circuit and thus determines the width of the output pulse. As shown by the wave form for point D, T<sub>2</sub> remains cut off until D reaches cutoff along the capacitor charge curve as determined by the time constant  $R \times C_t$  ( $75\text{mmf} \times 56\text{K} = 4.2$  microseconds).

When T<sub>2</sub> cuts off, the positive voltage shift at its plate is applied to point B through the 250mmf capacitor, thus holding the multivibrator on until  $R \times C_t$  can cause it to turn off, even though the effect of the input signal is no longer felt at point B. This is why the curve at point B remains flat at 0 volts in-

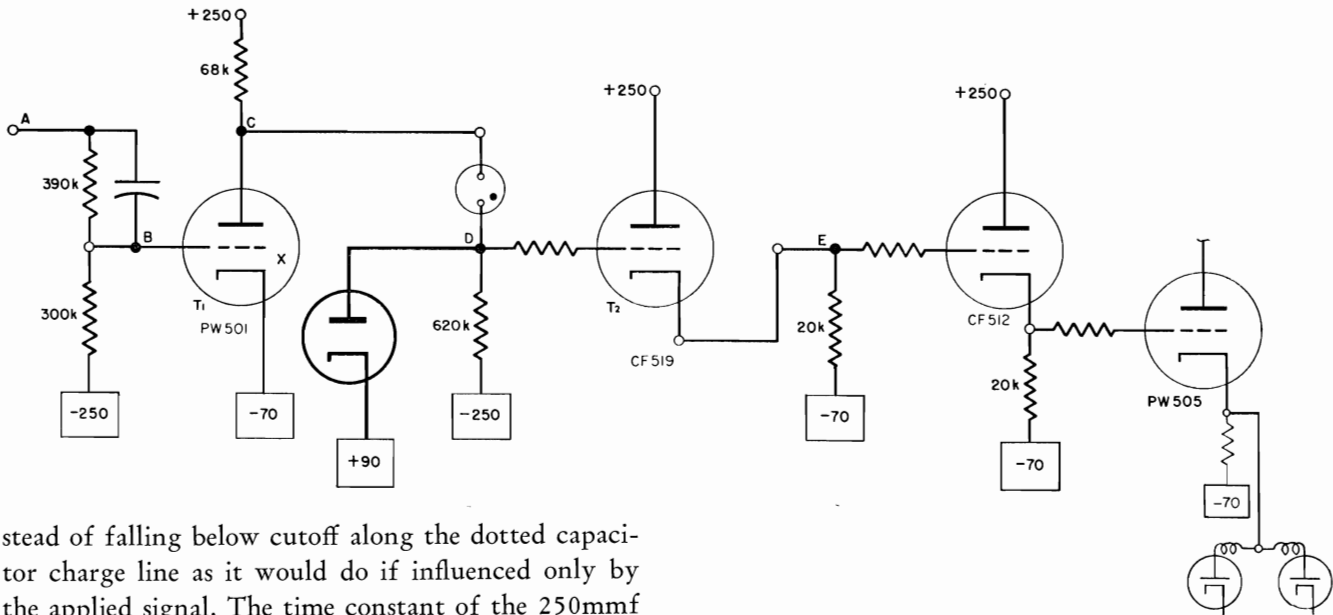

stead of falling below cutoff along the dotted capacitor charge line as it would do if influenced only by the applied signal. The time constant of the 250mmf capacitor and the 120K resistor is sufficient to hold B up longer than the period as determined by  $R \times C_t$ .

When D reaches the cutoff value,  $T_2$  again conducts. The negative shift at its plate is applied to point B, through the 250mmf capacitor, thus turning the multivibrator off. Point B drops to -30 volts where it is clamped by diode  $D_1$ .

$D_4$  prevents point D from rising above ground on its return swing.

The size of  $C_t$  can be varied to obtain different pulse widths.

The output from the multivibrator is usually taken from point B and is the relatively square positive pulse of the point B curve. The pulse is applied to another PW504 connected as shown, whose negative pulse output can be used to drive a cathode follower as shown or inverted again where a positive pulse is needed.

### Vacuum Diodes

Vacuum diodes are used in several places in the 650 where loads would be too severe for crystal diodes or where higher back resistances are needed for better isolation. The 6AL5, double-diode type is used for all vacuum diode applications.

A vacuum diode used as a clamp is illustrated in Figure II-29. The circuit shown is part of the head selection circuitry of the general storage read-write matrix.  $T_1$  is normally conducting, because point B

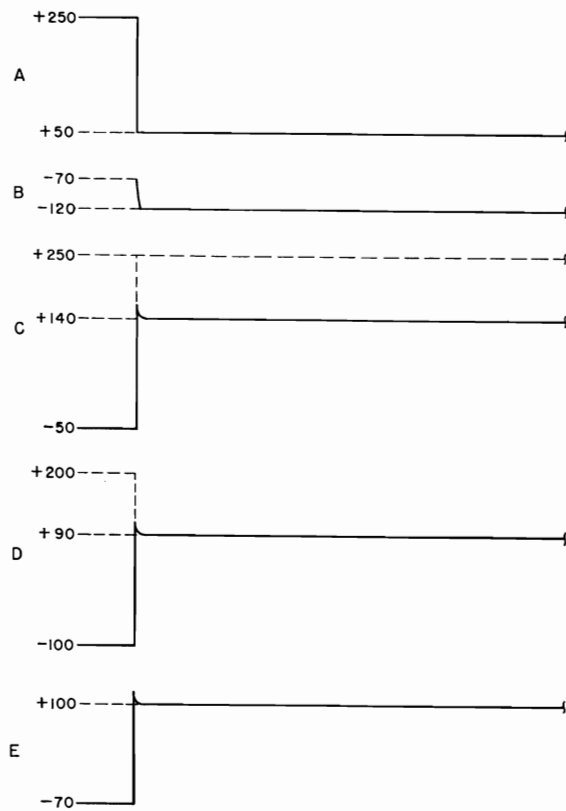

Figure II-29. Vacuum Diode Clamp

tends to approach -35 volts and the cathode is a -70 volts. The voltage divider tends to raise B to -35 volts, but grid current limits it to about cathode potential. With  $T_1$  conducting point C is at -50 volts

because about 300 volts is dropped across the 68K load resistor and about 20 volts across the tube. The voltage divider action of the 620K resistor and the neon bulb holds point D at  $-100$  volts and  $T_2$  is cut off. (The neon bulb maintains a constant 50-volt drop across itself as long as it is conducting.) With  $T_2$  cut off, point E is at  $-70$  volts.

When A drops to  $+50$  volts, the voltage divider allows B to drop to  $-120$  volts, cutting off  $T_1$ . Point C tends to rise to  $+250$  volts. As C rises, D is pulled up at the same rate, but always 50 volts below C because of the action of the neon bulb. In this fashion D tends to rise to  $+200$  volts but is clamped at  $+90$  volts by the vacuum diode, which conducts at this point, effectively shunting the 620K resistor and changing the proportions of the voltage divider system. The heavier current due to the conduction of the diode causes a greater drop across the 68K load resistor, and point C never reaches  $+250$  volts but stops at  $+140$  volts.

The object here is to raise point D from its initial  $-100$ -volt level to  $+90$  volts as rapidly as possible. To accomplish this, the large voltage swing of point C is used. The neon bulb provides 50-volt difference between points C and D and allows point D to vary between the desired limits while dropping some of the excess driving voltage. If a resistor were used in place of the neon bulb, of such a size as to allow point D to be at its initial  $-100$ -volt level, so much voltage would be dropped across it when point C rises that D would never reach the desired  $+90$ -volt level.

Vacuum diodes are also used in series with the magnetic-storage read and write coils in the general storage selection matrix to prevent back circuits between commonly connected points and in the basic capacitor storage cell from which the capacitor storage units are built up. These uses will be explained in more detail in connection with the specific circuits.

### Capacitor Storage

Capacitor storage units are used in the 650 for *working* storage, where the information must be available frequently and rapidly, for calculating and control purposes. These capacitor storage units (accumulator, distributor, and program register) are built up from basic capacitor storage *binary cells*, each of

which is capable of storing one binary bit by virtue of its two possible states, charged and discharged.

One such capacitor storage device is shown in Figure II-30. The basic cell consists of diodes  $D_1$  and  $D_2$  and the storage capacitor  $C_s$ .  $T_1$ ,  $T_2$ , and  $T_3$  are shown to illustrate typical controlling circuits.

The initial circuit conditions are as follows:

1.  $C_s$  discharged
2.  $T_1$  conducting at no-signal level; thus A is at  $-35$  volts
3.  $T_2$  cut off, thus B is at  $+150$  volts
4.  $T_3$  conducting at no-signal level; thus D is at  $-35$  volts and, because there is no charge on  $C_s$ , point C is also at  $-35$  volts.

$T_1$  and  $T_2$  are pulsed periodically by timing pulses from timing rings.

The pulsing of  $T_1$  provides a positive read-out gate and is followed by the pulsing of  $T_2$  which produces a negative read-in gate.  $T_3$  is pulsed under control of the capacitor storage read-in circuitry (not shown) and is active only when it is desired to *read-in* to the capacitor.

The capacitor is considered to be storing a binary 1 when it is *discharged* and a binary 0 when charged. Thus, reading into a capacitor storage cell requires that the capacitor be left discharged upon termination of the read-in gate.

The wave forms of Figure II-30 show how this is accomplished. When the read-out gate is applied, A rises to  $+10$  volts, causing  $D_1$  to conduct. This connects point C to point A and pulls C up to  $+10$  volts. This upward shift raises point D momentarily until the capacitor can charge and allow D to return to  $-35$  volts along the capacitor charge curve as determined by  $R \times C_s$ . This sharp pulse at D is obtained whenever the read-out gate tests a discharged capacitor. Had the capacitor been charged, no output pulse would appear. Termination of the read-out gate returns A to  $-35$  volts and effectively disconnects A and C, leaving C at  $+10$  volts. When the read-in gate is applied, B is lowered to  $+10$  volts, but with C also at  $+10$  volts there is no potential difference across  $D_2$  and no conduction occurs. No path is available to discharge  $C_s$ . Under these conditions the capacitor remains charged upon termination of the read-in gate. A 1 has been read out, and a 0 has been stored.

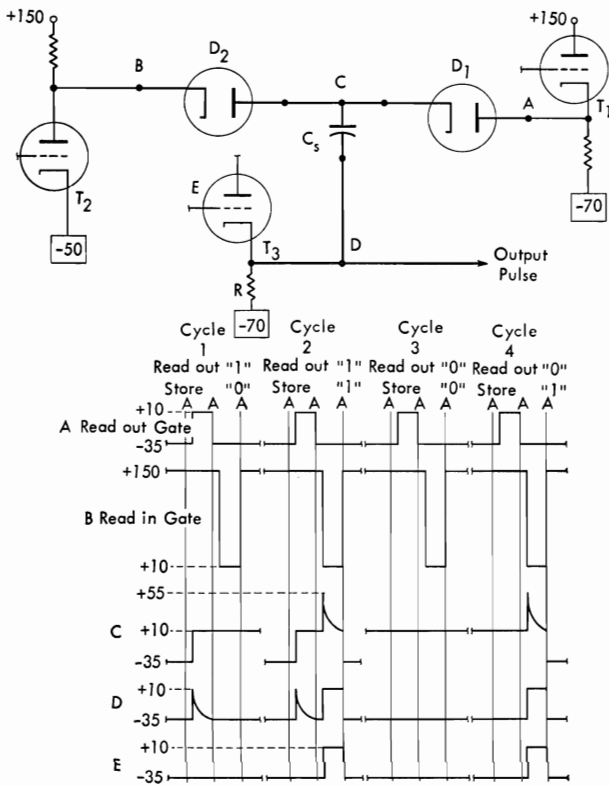

Figure II-30. Basic Capacitor Storage Device

Cycle 2 also assumes that  $C_s$  is discharged when tested by the read-out gate and an output pulse is obtained. Here, however, it is desired to store a 1 and the capacitor must be left discharged. To accomplish this, the read-in control circuits (not shown) cause the pedestal cathode follower ( $T_3$ ) to conduct simultaneously with the read-in gate. This causes D to be raised by an amount equal to the pedestal pulse from the output of  $T_3$ . This positive shift at D is reflected momentarily through  $C_s$  to point C. Thus when B is lowered to +10 volts by the read-in gate C, which was at +10 volts is simultaneously raised to +55 volts by the pedestal pulse. Under these conditions,  $D_2$  conducts, and  $C_s$  discharges through  $D_2$  and R while sitting on top of the pedestal. At the termination of the pedestal pulse, points D and C are lowered to -35 volts. The capacitor has been discharged during the read-in interval and a 1 is stored.

Cycles 3 and 4 show the action of the circuit under the other two possible conditions: read-out 0 and store 0, and read-out 0 and store 1.

Because a capacitor will not maintain a charge indefinitely, capacitor storage is a *non-sustaining* type of storage requiring periodic regeneration. In the 650 each capacitor has a read-out gate and a read-in gate applied to it once every word interval (96 microseconds) in the case of the distributor and program register storages, and once every two word intervals (192 microseconds) in the case of the accumulator storage. When the capacitor storage unit is required to read-out and retain its information for several word intervals, each cell must be regenerated once each word. This is accomplished by causing the output pulse obtained when a 1 is read out, and that is available several microseconds before read-in time, to actuate the read-in control circuits so that a pedestal pulse is obtained simultaneously with the read-in gate. Thus, when regenerating, any time a 1 is read out, a pedestal is obtained, and a 1 is read back into the same capacitor. If a 0 is read out, no output pulse is available to actuate the read-in control circuits, no pedestal is obtained and a 0 is read back in. Cycles 2 and 3 illustrate the two possible conditions during regeneration.

When it is desired to read a new word into a capacitor storage unit, the path between the output pulse and the read-in control circuits is blocked, and the read-in controls, and consequently the pedestal cathode followers, are actuated by information pulses from the read-in source.

A later section will describe how several capacitor storage cells are combined and controlled to form a bi-quinary, serial storage unit capable of storing the digits of one or two words.

## GERMANIUM CRYSTAL DIODES

THE germanium crystal diodes used in the 650 are supplied by two different vendors. They are similar electrically. The physical construction and polarity markings are shown in Figure II-31. An additional marking in the form of a painted red dot may be found on the anode end.

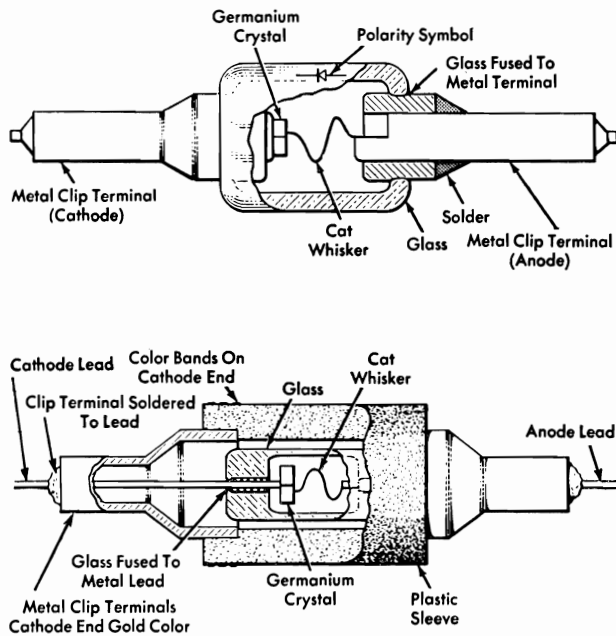

Figure II-31. Germanium Crystal Diodes

These diodes are sealed in glass to protect against moisture and temperature variations. The characteristics, however, are greatly affected by the operating temperature. In general, the front-to-back current or resistance ratio decreases as temperature increases, thus decreasing the diodes' effectiveness. At about 100 degrees C., germanium no longer exhibits semiconductor characteristics, and a temperature in excess of about 150 degrees C. will permanently alter its behavior. For this reason the pluggable diode units are mounted in vertical rows on each chassis, and cooling air is circulated by blowers at the top and bottom of each gate.

These diodes are especially manufactured for computer use. They have a minimum back resistance of about 400K and a maximum forward resistance of about 200 ohms, under operating conditions. Attention is also given to forward and reverse *recovery times* when diodes are used in pulsed circuits.

## PLUGGABLE UNITS

As in previous IBM calculators, functional units are built in pluggable unit assemblies. The pluggable units use miniature ten-pin basis, which plug into wired sockets mounted on chassis.

In the console unit there are three gates of three chassis each, and in the power unit there is one gate mounting two chassis. On machines manufactured after February, 1956, the power unit contains a maximum of two gates of three chassis each. One of the chassis consists of relays. There is also a small relay gate mounted above the cable connectors on the end of the power unit. Pluggable units are located on the chassis by columns A through Z (except O and I) and rows 1 through 11 as in previous electronic calculators.

All tubes are part of pluggable units. Units are named according to function. Inverter units are identified with an IN prefix such as IN501, IN503, etc. Cathode followers, power units, voltage amplifiers, shaping amplifiers, thyratrons, double vacuum diode units, and capacitor storage units are similarly identified with the prefixes CF, PW, VA, SA, TH, DD, and CS respectively.

Several types of CF, IN and PW units are provided. Use of a particular type depends on the circuit requirements. An inverter unit may serve as two separate single inverters or its sections may be combined to act as a double inverter. Examples of these are the IN503 and the IN501.

Several types of cathode follower units provide different load resistance values, various types of grid divider, and input arrangements, etc. Many cathode follower units, such as the CF501 and the CF502 are duplicates except for the use of the 6350 tube instead of the 5965 to provide more drive.

Germanium crystal diode switch and mix circuits are also built up in pluggable units. In the 650, up to twelve diodes are mounted in a pluggable unit. The associated resistors used in the switch or mix circuits are connected externally. The diodes are clipped into the units, allowing easy replacement of individual diodes without need of soldering. With this arrangement, one pluggable diode unit may comprise several logical switch or mix functions.

The logical circuits have been formed using various configurations of the pluggable diode units. Each pluggable diode unit frame is the same, including the wiring between pins and diode clips, and each has the same part number. The several configurations are determined by the number of diodes used, their position within the unit, and the direction in which they are clipped into the unit.

The basic configuration, with all diodes clipped in the forward direction, is shown in WD 00-05. A diode chart in the wiring diagram, in chassis location order, lists the diodes used in their direction.

All pluggable unit schematic and point-to-point diagrams, together with the representative block diagram of the unit, as shown in the wiring diagram.

Two types of pluggable units containing only capacitors are used as voltage supply filters on chassis 6. These units are named according to the size and working voltage rating of the capacitors that they contain; i.e., C-30-30-150 and C-20-450 (WD 00-16).

## BLOCK SYMBOLS

To SIMPLIFY the logical representation of circuits, a system of block diagrams is used. Each block symbol represents a basic function. An effort has been made to identify the functional classification of a unit by the configurations of its block symbol. The physical location of the unit represented is shown over the block, and the unit-type identification, as well as the pin numbers, is shown for cross-referencing to the detailed pluggable unit drawings.

WD 00-07 through 00-16 and 00-30 show the block symbols that are used for 650 circuit representation. The most common tube functions are single inverters and cathode followers, both single-triode functions. These are shown as a square block with grid input on the left and anode or cathode output from top or bottom as the case may be. In each case these are half of a pluggable unit. When both halves of a unit are used for a single function, as in double inverters, the block is a rectangle with twice the area of a half unit. Double diode pluggable units contain two, double vacuum diode tubes (6AL5's), or four diode functions. Thus, a DD functional block is a rectangle, one half the area of a half unit block.

A single latch is made of a double inverter and a cathode follower (WD 00-30). Connections between the inverter output anode and the cathode follower grid need not be included every time a latch symbol appears. Thus, a latch symbol is an IN rectangle and a CF square joined as shown. Similarly, a double latch is an inverter plus two cathode followers, one on each side. Where latch input circuitry utilizes diode

switches and/or mixes, these will be shown as separate diode blocks. These distinctive latch configurations will help to locate latches on the wiring diagram. This is an advantage because latches are usually key components of a logical circuit.

On latch symbols grid inputs are shown entering the block from the bottom (left or right) instead of the left side as on other tube symbols in order to make room for the adjoining cathode followers.

In all other cases grid inputs are straight in from the left if there is no grid voltage divider network built into the unit. When a divider is a part of the unit, the grid input terminal is shown above the grid level as in the CF503.

## Block Symbol Voltage Codes

When a unit has a built-in load resistor, this is indicated by a small box in the lower left corner of the block if it is a cathode follower, or the upper left corner if it is an inverter. If the load resistor is used, as is usually the case, the number in the box is the code number for the service voltage to which the load resistor is connected. These voltage codes are shown in WD 00-04.

Special input circuitry such as capacitors and diode clamps are shown as in the CF509, CF513, and CF516. Where a cathode load resistor for a preceding stage, which contains no built-in resistor of its own, is in the input of the next stage, it is shown as in the CF512. Here the cathode terminal of one-half of a CF512 may be connected directly to the grid terminal of the other half by wiring pin 5 to 6 or 3 to 8, thus obtaining successive cathode follower stages.

Input and output pin numbers are shown adjacent to the terminal. In general, in the case of cathode followers and inverters, pins 3 and 5 are associated with the input and output terminals respectively, of one half of a unit while pins 6 and 8 are associated with the other half. In this way the pin numbers also serve to identify the unit half represented by a block.

In some cases where it is helpful to know that a tube element connects to an unusual voltage, this is shown. An example is the cathode of an IN505 which connects to -22 volts rather than ground.

One pluggable capacitor storage unit contains two capacitor storage cells (two 6AL5's and two capacitors). These are shown as two separate functional



blocks with the same chassis location. Pins 3 and 4 are read-out gate terminals, 8 and 7 are read-in gate terminals while 6 and 10 are output pulse and pedestal input terminals.

In general, power units are shown as a block representative of their basic function as either an inverter or cathode follower. Special power units like the PW502 and PW503 have their own special block representation.

Voltage amplifiers and shaping amplifiers are actually special types of double inverters.

Thyratrons are the one departure from the basic system of using a full-size rectangle for a full pluggable-unit function. This was done to conserve wiring diagram space, because thyratrons are arranged in a matrix. In this block grid 1 and 2 inputs are from the left, cathode is at the bottom, and anode at the top.

A crystal diode pluggable unit may comprise several logical switch and/or mix functions. For this reason the block representation uses several blocks with the same chassis location. Each switch or mix function contained in a pluggable unit is shown as a separate switch or mix block.

To distinguish crystal diode functions from tubes, the shape and size of the blocks have been made distinctive. Further to distinguish between a diode switch function and a diode mix function, the blocks are shown in distinctive positions. The switch (AND circuit) is shown as a long, low block with inputs to the bottom and output from the top. The mix (OR circuit) is shown as a narrow, high block with inputs to the left side and output from the top. This same block proportion is carried into the higher level diagrams.

### TIMING PULSES AND GATES

#### Basic Recorded Pulses

Information is recorded in the buffer storages and general storage by switching information gates with timing pulses to produce a specifically timed information pulse for energizing the writing heads.

Information is read from magnetic storage by switching a shaped, read head signal with a timing pulse to produce a specifically timed information pulse

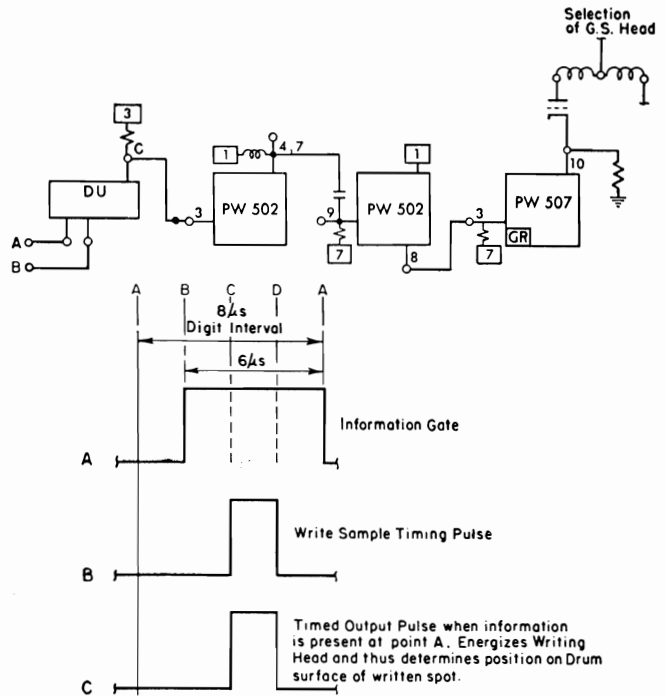

Figure II-32. Principle of Magnetic-Storage Writing

that can be used to turn on a latch whose output will be an information gate similar in duration and timing to the one originally used in recording the spot.

Figures II-32 and II-33 illustrate these principles of magnetic-storage writing and reading.

A capacitor storage unit (distributor), whose output pulses are in the form of information gates, is frequently the source of information thus recorded in general storage. Also, capacitor storage units (distributor or program register) whose input circuits will respond to information gates, are frequently the destination of such information read from general storage.

Notice that the timing pulses occur at about the mid-point of the information gate interval when writing, and at the middle of the shaper output interval when reading.

Thus timing pulses determine the position of a spot when it is placed on the drum and also insure that information read from the drum is available in the form of a properly timed information gate. In a similar way, other necessary drum timing divisions are established by timing pulses such that the exact position of the drum is known by the computing and control circuits at all times.

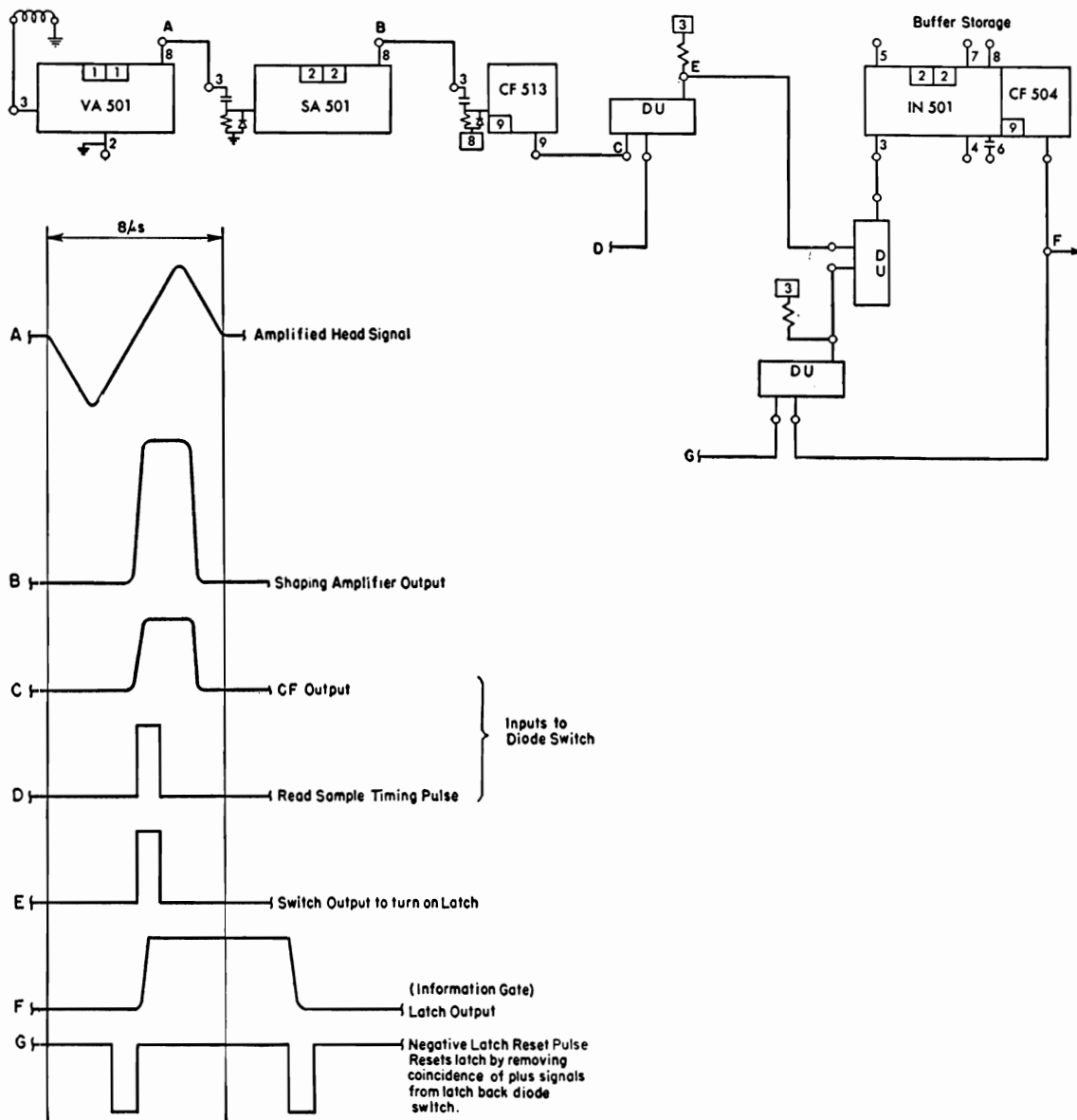

Figure II-33. Principle of Magnetic-Storage Reading

Figure I-8 shows the principal drum timing divisions. All drum times are with relation to HOME position, which is the beginning of sector 0. Other drum divisions are sectors (5 per drum revolution), words (50 per drum revolution), digits (600 per revolution), and A, B, C, and D pulse, one of each per digit or 600 per drum revolution.

The basic timing interval is the eight microsecond digit interval, of which there are 600 around the cir-

cumference of the drum. Each digit interval is divided into four equal pulse intervals, A, B, C, and D. The beginning of a digit timing interval is marked by the leading edge of its A pulse. The B, C, and D pulses of a digit follow at two microsecond intervals. Twelve-digit intervals, each with its A, B, C, and D pulses are included in a work interval. The twelve digits of each word are successively, DX, D0, D1, D2, D3, D4, D5, D6, D7, D8, D9, D10. DX is used

as a switching interval between successive words, D0 is the sign storage time and D1-D10 represent the serial time space intervals for the storage of the units through tenth-position digits of a 10-digit number. Ten-word intervals are included in each sector, and five sectors comprise the entire cycle of drum timing.

Just as the beginning of a digit interval is marked by its A pulse, pulses must be available to mark the beginning of each word, sector, and home interval. These basic timing pulses are obtained by reading permanently recorded spots on the drums' timing tracks. These timing spots are initially recorded at the factory from a master drum and are spaced with relation to the home pulse for proper timing relationships. Exact timings are finally obtained by adjustment of the individual timing track heads while observing the pulse on an oscilloscope. An auxiliary set of timing tracks is recorded at the factory.

There are six timing tracks for the six basic, recorded timing signals:

1. Home pulse
2. Sector pulses
3. Word pulses
4. B pulses
5. D pulses
6. RSP—Read Sample pulses

The other necessary timing pulses and gates are obtained from multivibrator or latch circuits actuated by these basic pulses and/or other *manufactured* pulses.

### GLOSSARY OF 650 TIMING DESIGNATIONS

THE following list defines terms used to describe timing pulses and gates and describes the pulses and gates used in the 650. Figures II-34 through II-38 illustrate these pulses and gates.

#### Timing Designations

**Bit** Smallest unit of information. A bit usually represents any one element of the seven-element bi-quinary code, or the five-element, general storage code.

**Digit (D)** Elements of bi-quinary or five-element code representing one decimal number such as six (6). Bits representing a digit are present simultaneously within a time interval of eight microseconds. A valid digit-code designation contains only two positively identified code elements. One of twelve intervals of a word.

**Home Pulse (HP)** A recorded spot on the drum, which is a reference point for all timing signals.

**Micro-second** One millionth of a second.

**Sector (S)** A designated area representing one fifth the circumference of the drum.  
A sector contains ten words per band and represents a time interval of .96 milliseconds.

**Word (W)** A combination of twelve-digit intervals representing the smallest *addressable* storage unit of information.  
A word contains ten digits (D1-D10) representing numerical information, plus one digit (D0) indicating sign, plus one digit (DX) allowed for a switching interval between words.

**DX D0 D1 D2 D3 D4 D5 D6 D7 D8 D9 D10**

**Pulse (P)** Basic timing signal, usually 2 microseconds duration.  
Most pulses are obtained from permanently recorded signals on the drum that are amplified and shaped. Some pulses are generated from other pulses.

**Gate** Any created timing signal usually over 2 microseconds in duration that represents an exact timing signal between two pulses. Note: Any signal not labeled pulse is assumed to be a gate and has no basic abbreviation.  
Gates are usually created by switching certain timing signals or by timed control of latch circuitry.

## Timing Designations with Abbreviations

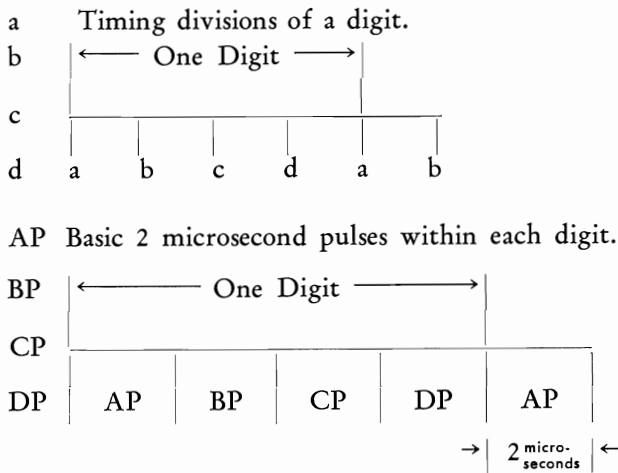

Six hundred pulses per drum revolution, 8 microseconds apart.

*A Pulse (AP).* A positive pulse, 2 microseconds duration, occurring during the first quarter of a digit interval. A pulses are produced from a one-shot multivibrator, which is controlled by the leading edge of a delayed early A pulse and the leading edge of a negative B pulse.

*B Pulse (BP).* A positive pulse, 2 microseconds duration, occurring during the second quarter of a digit interval. B pulses are obtained from permanently recorded signals on the magnetic drum.

*C Pulse (CP).* A positive pulse, 2 microseconds in duration, occurring during the third quarter of a digit interval. C pulses are produced from a one-shot multivibrator controlled by the trailing edge of a negative B pulse and the leading edge of a negative D pulse.

*D Pulse (DP).* A positive pulse, 2 microseconds in duration, occurring during the fourth quarter of a digit interval. D pulses are obtained from permanently recorded signals on the magnetic drum.

Pulses that occur just prior (less than 2 microseconds) to a designated pulse time are signified with a prefix *E* meaning *early*. Early pulses are often used to compensate for time lost between stages of electronic circuitry that require an output at a certain designated pulse time.

*Early A Pulse (EAP).* A positive pulse, 2 microseconds in duration, designed to occur about  $\frac{1}{2}$  microsecond prior to an A pulse. Early A pulses are obtained by delaying D pulses. Six hundred pulses per drum revolution, 8 microseconds apart.

*Early Word Pulse (EWP).* A positive pulse, 2 microseconds in duration, which occurs at early A pulse time every twelfth digit. Early word pulses are obtained from permanently recorded signals on the magnetic drum and are associated with DX, the first digit time of every word. Fifty pulses per drum revolution, 96 microseconds apart.

*Early Sector Pulse (ESP).* A positive pulse, 2 microseconds in duration, which occurs at early A pulse time every one-hundred-twentieth digit (or every tenth word). Early sector pulses are obtained from permanently recorded signals on the magnetic drum and are associated with DX, word 0, the first digit of the first word of every sector. Five pulses per drum revolution, 960 microseconds apart.

*Early Home Pulse (EHP).* A positive pulse, 2 microseconds in duration, which occurs at early A pulse time once every drum revolution. Early home pulse is obtained from a permanently recorded signal on the magnetic drum. Early home pulse is associated with DX, word 0, sector 0, the first digit of the first word of the first sector. One pulse per drum revolution, 4.8 milliseconds apart.

*Home Pulse (HP); Word Pulse (WP).* These pulses, 2 microseconds in duration, are obtained by delaying their respective *early* pulse about  $\frac{1}{2}$  microsecond so that these pulses occur at A pulse time.

*Word Pulse (Even Word); WPL (EvW).* A positive word pulse, 2 microseconds in duration, which occurs for only every even word (192 microseconds apart). Words 0, 2, 4, 6, 8 are considered even words and are associated with lower accumulator read-out time.

*Word Pulse (Odd Word); WPU (OdW).* A positive word pulse, 2 microseconds in duration which occurs for only every odd word (192 microseconds apart). Words 1, 3, 5, 7, 9 are considered odd words and are associated with upper accumulator read-out time.

Negative timing pulses are signified with a prefix N. Negative pulses are obtained by inverting normal pulses. A negative pulse therefore has a positive voltage level except during the designated pulse time.

*NAP* }  
*NBP* } Basic timing pulses within each digit  
*NCP* } (negative).  
*NDP* }

*NEAP*. Negative Early A Pulse  
*NEHP*. Negative Early Home Pulse  
*NHP*. Negative Home Pulse  
*NESP*. Negative Early Sector Pulse  
*NEWP*. Negative Early Word Pulse  
*NWP*. Negative Word Pulse

*NWPL (EvW)*. Negative Word Pulses occurring only for every even word.

*NWPU (OdW)*. Negative Word Pulses occurring only for every odd word.

*Negative Latch Reset Pulse (NLRP)*. A negative pulse, about 1 microsecond in duration, which occurs at the beginning of A time. This pulse is obtained from a *one-shot* multivibrator triggered by an A pulse. This pulse is used to control the reset of some of the latches used in magnetic storage.

**Special Pulses**

*Read Sample Pulse (RSP)*. A positive pulse, about 1 microsecond in duration, which occurs near B time. Read sample pulses are used to sample information gates from the magnetic storage read-out circuitry. Read sample pulses are obtained from permanently recorded signals on the magnetic drum. Six hundred pulses per drum revolution, 8 microseconds apart.

*Write Sample Pulse (WSP)*. A positive pulse, 2 microseconds in duration, which is similar to a C pulse. Write sample pulses are obtained from a one-shot multivibrator controlled by the trailing edge of a negative B pulse and the leading edge of a negative D pulse. These pulses are used for sampling information gates that feed magnetic storage write amplifying circuitry. Six hundred pulses per drum revolution, 8 microseconds apart.

Upper case characters are used to designate timing gates, operational terms, or functional units.

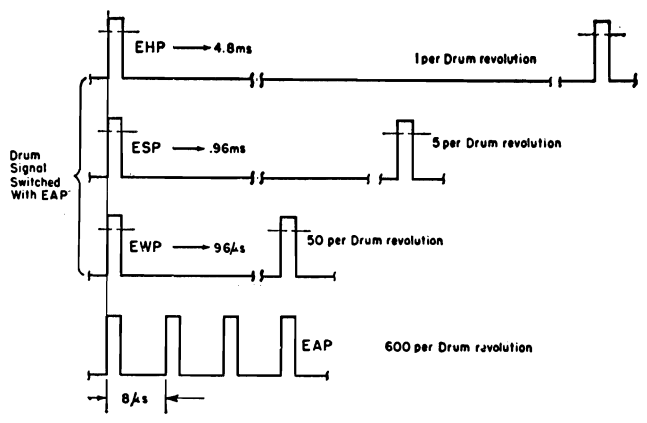
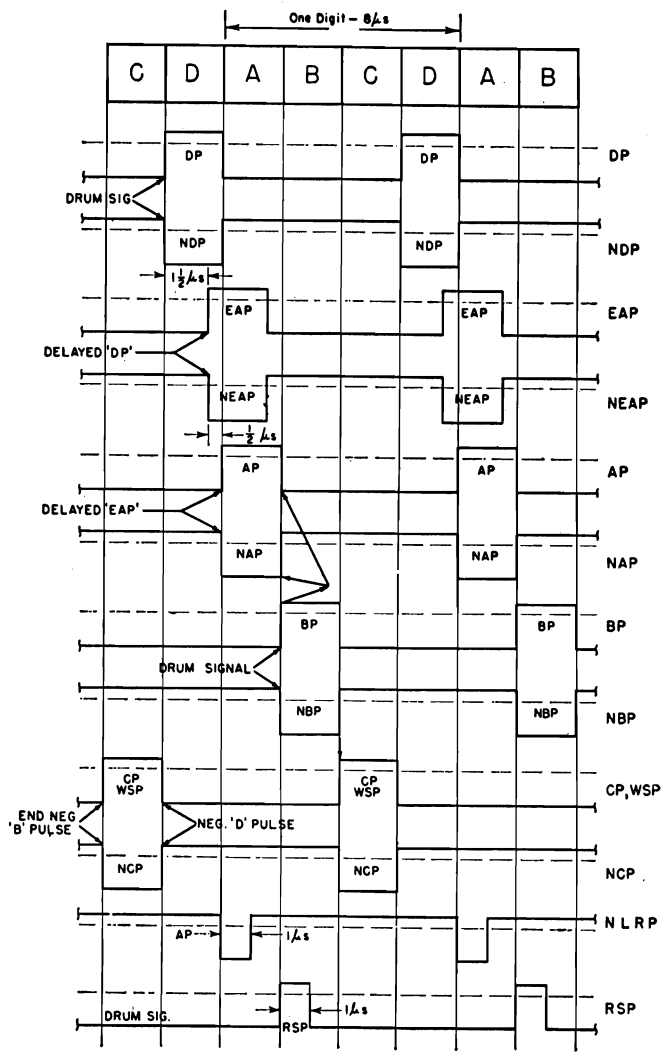

Figure II-34. 650 Timing Pulses

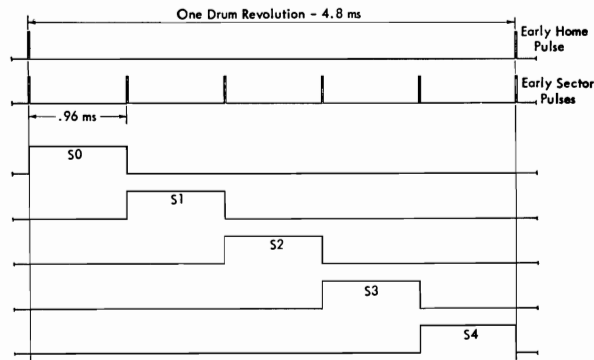

Figure II-35. Sector Gates

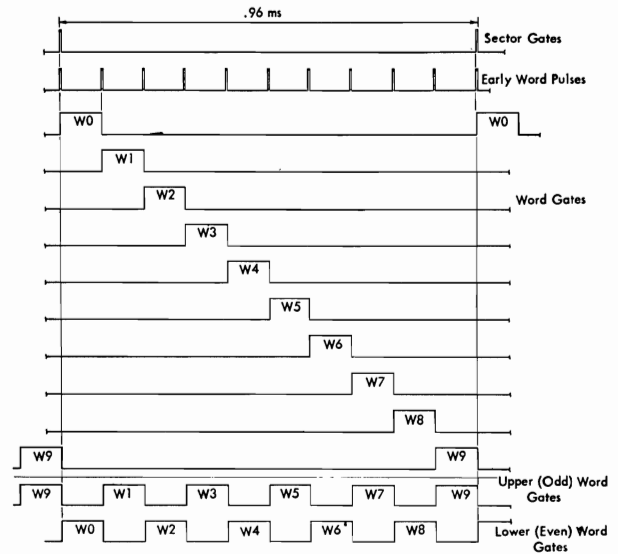

Figure II-36. Word Gates

### Timing Gates

Digit gates are initiated at A time but are considered on only from B time of the designated digit to A time of the following digit.

*DX*. Switching digit gate—one digit time allowed for a switching interval between words.

*D0*. Sign digit gate—one digit time allowed for sign indication.

<p><i>D1</i> <i>D2</i> <i>D3</i> <i>D4</i> <i>D5</i> <i>D6</i> <i>D7</i> <i>D8</i> <i>D9</i> <i>D10</i></p>	}	<p>Digit gates 1 through 10 designated for numerical information. Digit 1 represents units position, digit 10 represents high-order position.</p>
---	---	---

*D1-D5*. A gate providing digit gates 1-4 only.

*D5-DX*. A gate providing digit gates 5-10 only.

*D5-D10*. A gate providing digit gates 5-9 only.

*D1-DX*. A gate providing all digit gates except *D0* and *DX*.

*D5-D9*. A gate providing digit gates 5-8 only.

*D10, D1-D5*. A gate providing digit gates 10 and 1-4 only.

*D10U (OdW)*. Digit 10 gate on every odd word. (Upper accumulator read-out time.)

*(Od) D*. Digit gates occurring only for every odd digit. (X, 1, 3, 5, 7, 9.)

*(Ev) D*. Digit gates occurring only for every even digit. (0, 2, 4, 6, 8, 10.)

*DXcU-D1cU*. A gate on from C time of switching digit X to C time of digit 1 occurring only for every odd word. Odd word gates are associated with upper accumulator read-out time.

*D10cL-D0cU*. A gate on from C time of digit ten of an even word to C time of sign digit 0 of the following odd word.

*N(D10cL-D0cU)*. A gate on from C time of digit zero of an odd word to C time of digit ten of an even word.

The following gates have a prefix E which indicates early digit gates which are initiated at D time of the previous digit but are considered on only from A time to D time of the designated digit.

*EDX*. Switching digit gate.

*NEDX*. A gate positive for all digits except *EDX*.

*EDXL (EvW)*. Switching digit gate occurring only for every even word (lower accumulator read-out time).

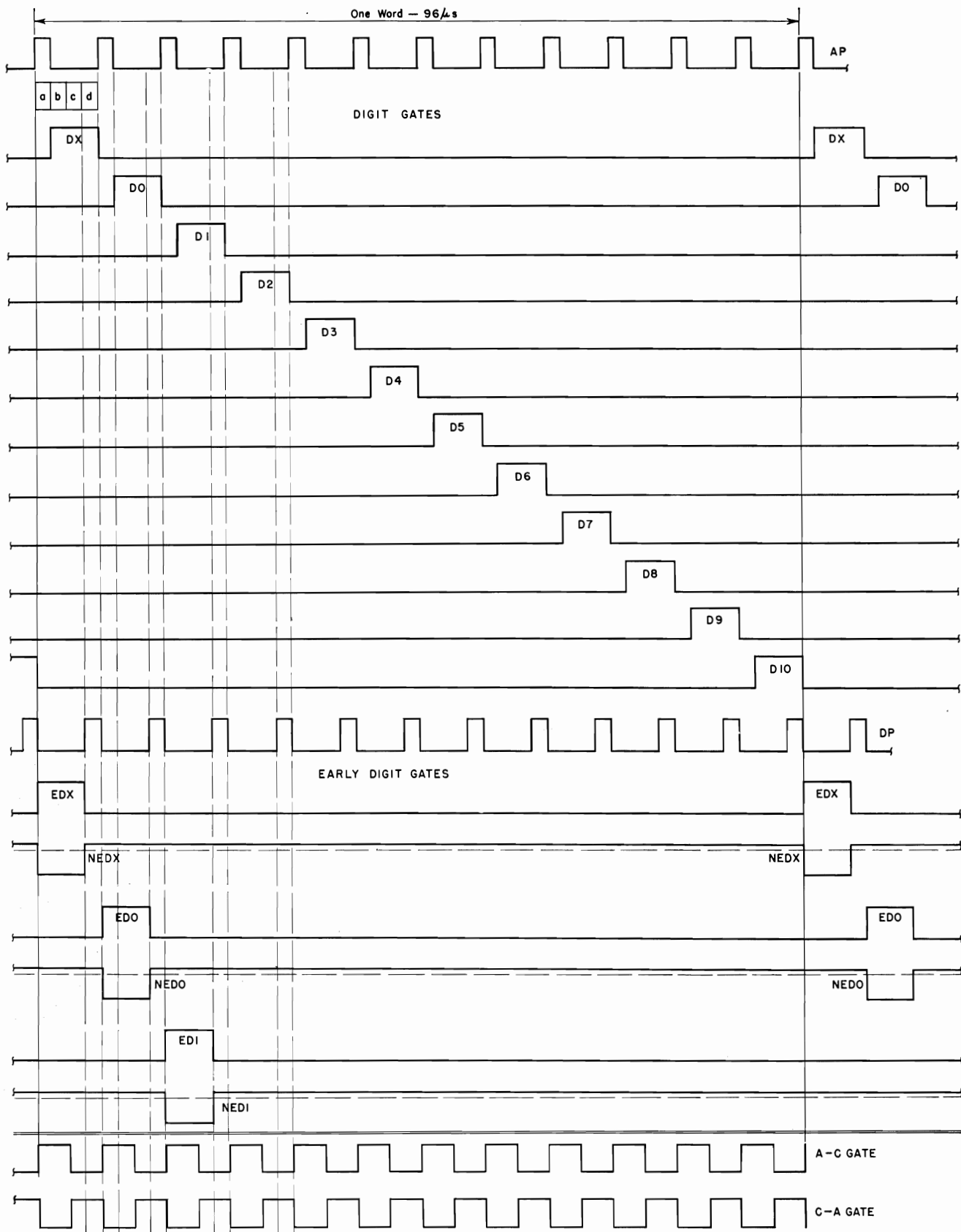

Figure II-37. Digit Gates

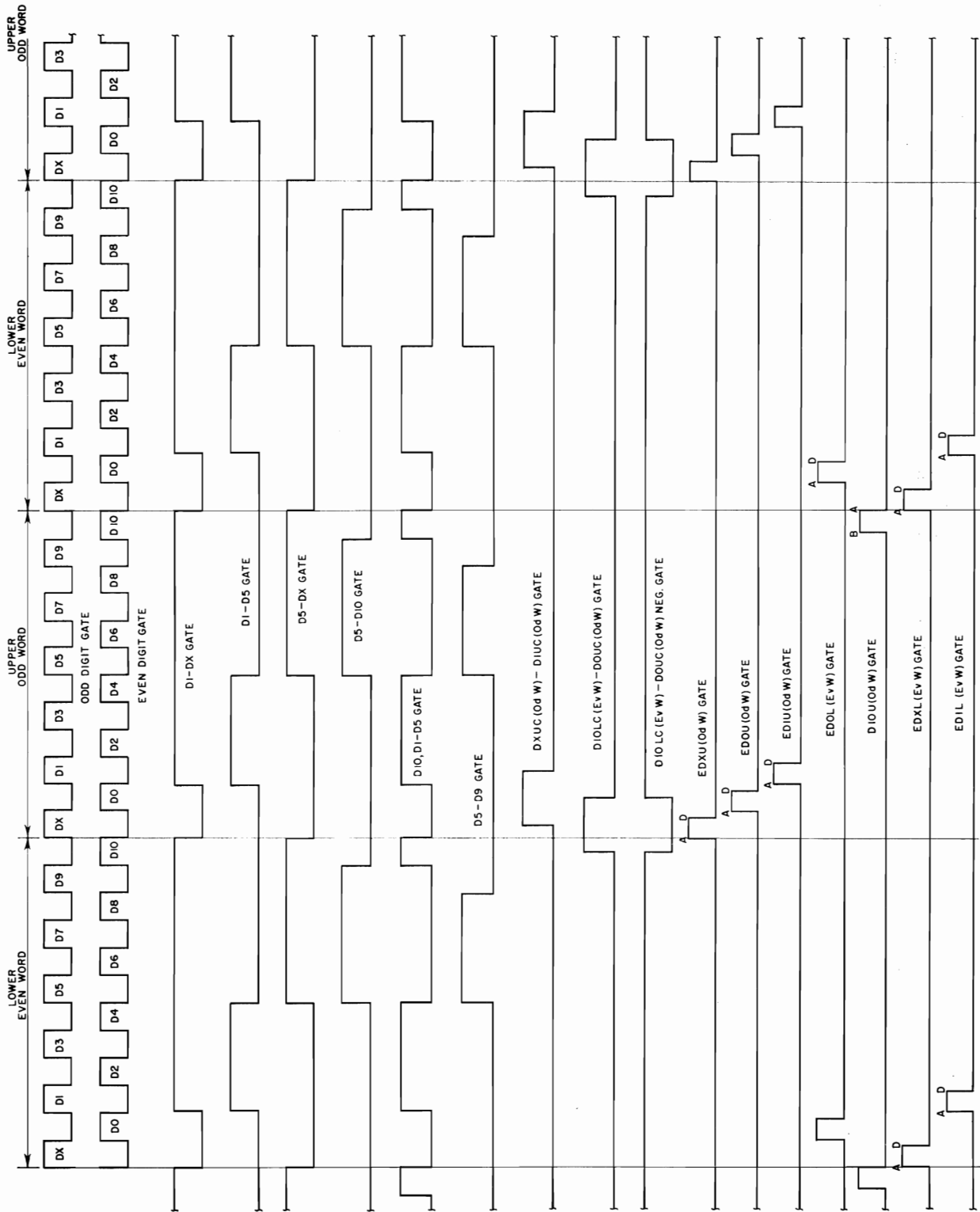

Figure II-38. Special Gates



*EDXU (OdW)*. Switching digit gate occurring only for every odd word (upper accumulator read-out time).

*NEDXL (EvW)*. A gate positive at all times except EDX of even words (lower accumulator read-out time).

*NEDXU (OdW)*. A gate positive at all times except EDX of odd words (upper accumulator read-out time).

*ED0*. Sign digit gate.

*NED0*. A gate positive for all digits except ED0.

*ED0L (EvW)*. Sign digit gate occurring only for every even word (lower accumulator read-out time).

*ED0U (OdW)*. Sign digit gate occurring only for every odd word (upper accumulator read-out time).

*ED1*. Digit one gate.

*NED1*. A gate positive for all digit times except ED1.

*ED1L (EvW)*. Digit 1 gate occurring only for every even word (lower accumulator read-out time).

*ED1U (OdW)*. Digit 1 gate occurring only every odd word (upper accumulator read-out time).

*ED2*. Digit 2 gate.

*NED2*. A gate positive for all digits except ED2.

*ED2L (EvW)*. Digit 2 gate occurring only for every even word (lower accumulator read-out time).

Sector gates are considered on from B time of digit X, word 0 to A time of the following digit X, word 0 (ten words).

S0.	} Sector Gates 0-4. Positive signals from a ring lasting approximately 960 microseconds. These gates distinguish one of five drum sectors.
S1.	
S2.	
S3.	
S4.	

Word gates are considered on from B time of digit X to A time of the following digit X (twelve digits).

W0.	} Word Gates 0-9. Positive signals lasting 96 microseconds. These gates establish the position of a word in a sector.
W1.	
W2.	
W3.	
W4.	
W5.	
W6.	
W7.	
W8.	
W9.	

*WL (EvW)*. Word gates occurring only for every even word (0, 2, 4, 6, 8; lower accumulator read-out time).

*WU (OdW)*. Word gates occurring only for every odd word (1, 3, 5, 7, 9; upper accumulator read-out time).

A-C. Timing gate on from A to C time within each digit (equivalent of AP + BP).

C-A. Timing gate on from C to A time within each digit (equivalent of CP + DP).

Figures II-39 through II-49 illustrate typical circuitry used to obtain timing pulses and gates. In these circuits, extensive and flexible use is made of the single-shot multivibrator circuit of Figure II-28. This is explained in the section on basic electronic circuits. The curves of voltage wave forms at key points of the circuits show how the desired pulse is obtained.

The sector, word, and digit gates illustrated in Figures II-35, II-36, and II-37 are developed by latch ring circuits as shown in Figure II-49. Figure II-50 illustrates the timing for a digit ring.

The wiring diagram sections on timing circuits show the details of the development of all timing pulses and gates.

These circuits can be found on wiring diagram sections 1-00, 1-10, and 1-20. Sections 1-30, 1-33, and 1-34 show the circuits of the sector ring, word ring, and digit ring, respectively.

### PRINCIPLES OF MAGNETIC-DRUM STORAGE

THE 650 utilizes a revolving magnetic drum for storing information in the form of small magnetized spots on its surface. This system of storage offers a large storage capacity in small space together with reasonably fast access.

It is well known that a current through a coil around a bar of magnetic material will induce the bar to become a magnet having a north and south pole at either end (Figure II-51). Which end becomes the north pole is dependent upon the direction of the current in the coil. This magnet has associated with it a magnetic field, the approximate distribution of which is shown by the dotted lines of Figure II-51. This field exerts a magnetizing force on materials placed in it.

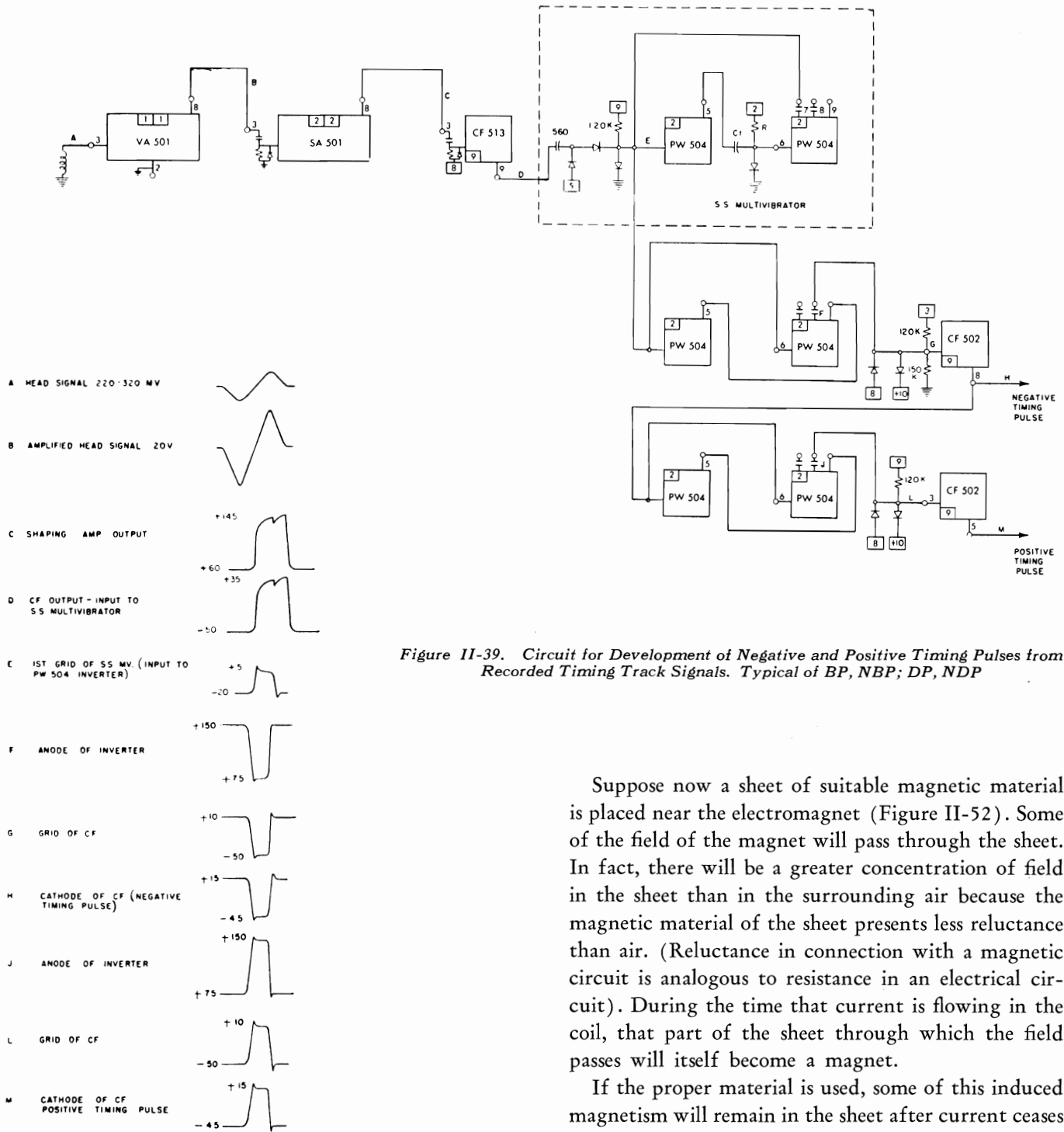

Figure II-39. Circuit for Development of Negative and Positive Timing Pulses from Recorded Timing Track Signals. Typical of BP, NBP; DP, NDP

Suppose now a sheet of suitable magnetic material is placed near the electromagnet (Figure II-52). Some of the field of the magnet will pass through the sheet. In fact, there will be a greater concentration of field in the sheet than in the surrounding air because the magnetic material of the sheet presents less reluctance than air. (Reluctance in connection with a magnetic circuit is analogous to resistance in an electrical circuit). During the time that current is flowing in the coil, that part of the sheet through which the field passes will itself become a magnet.

If the proper material is used, some of this induced magnetism will remain in the sheet after current ceases to flow. The fact that current was made to flow in the coil has been recorded in the sheet, and this fact could be detected by passing a compass needle over the sheet. The polarity of the recorded spot would indicate the direction of flow of the current through the coil. This is the principle of magnetic storage.

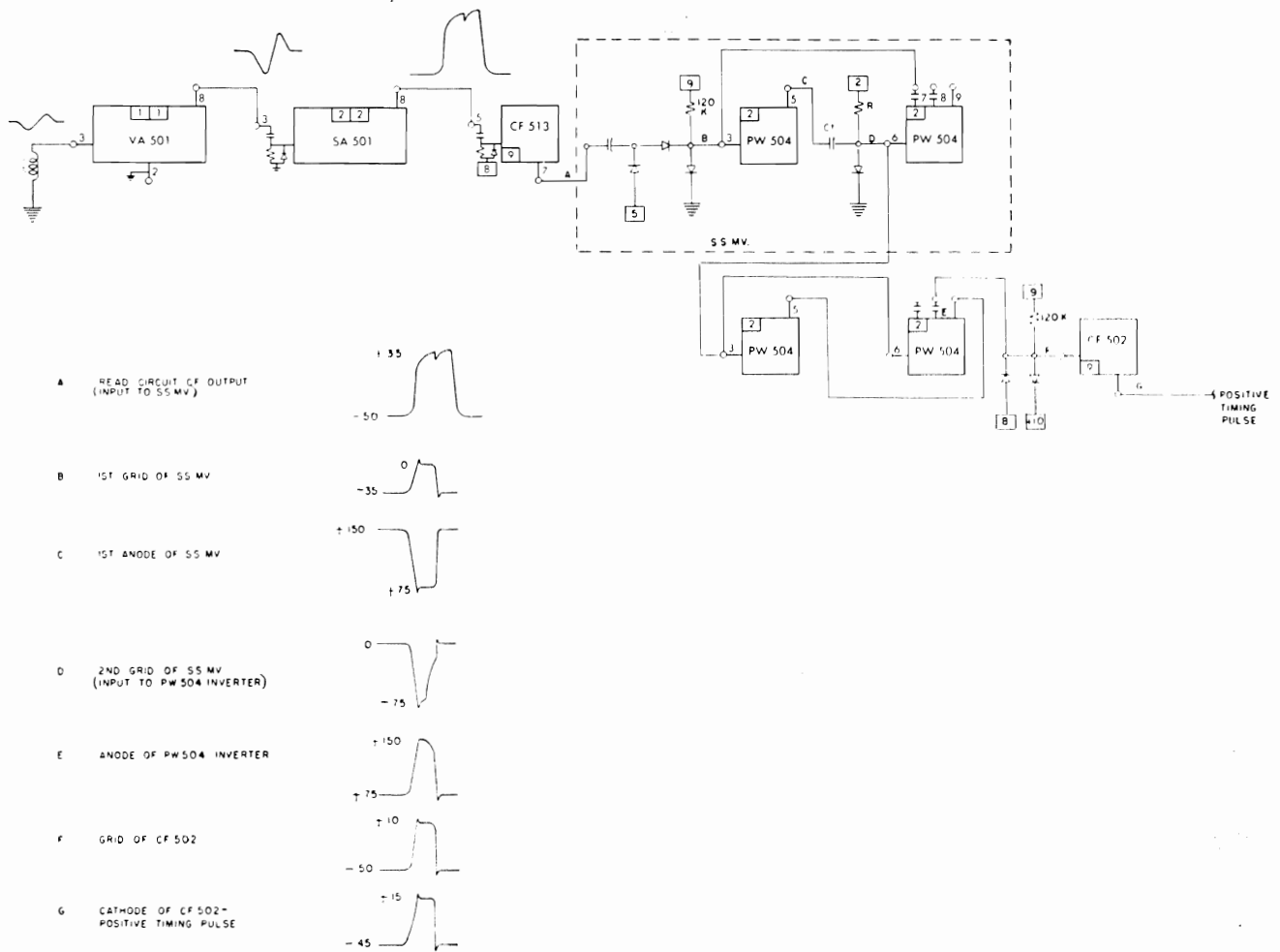

Figure II-40. Development of Positive Timing Pulse from Timing Track Signal when Similar Negative Pulse Is Not Required. Typical of Read Sample Pulse.

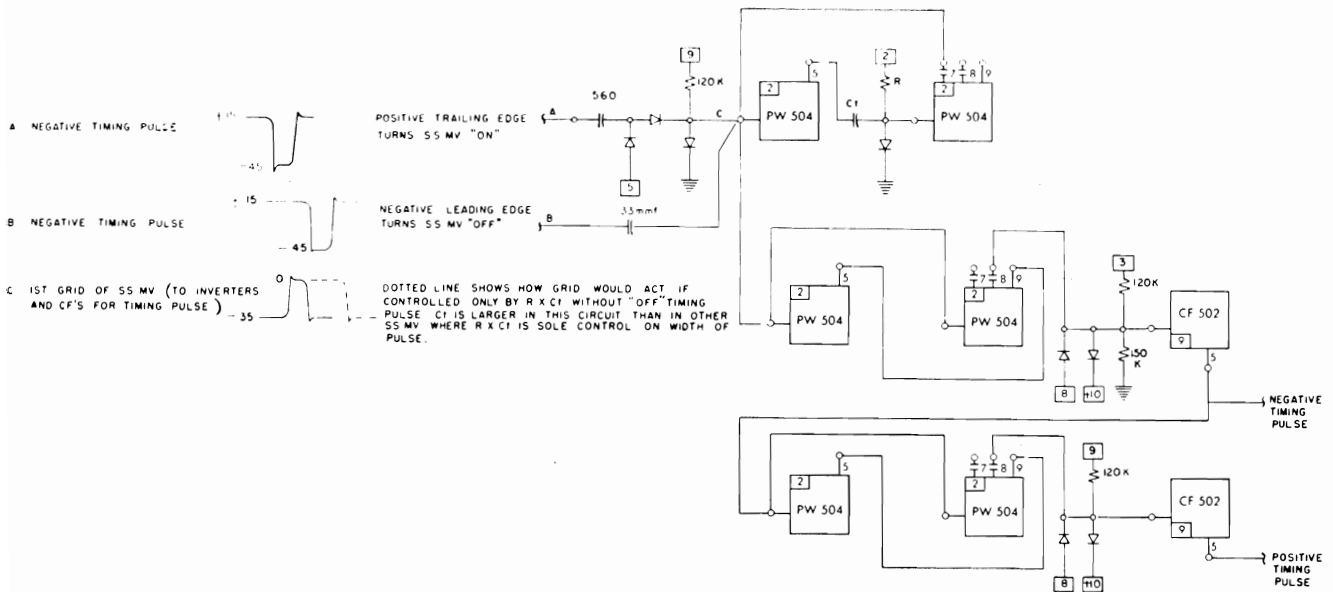

Figure II-41. Development of Negative and Positive Timing Pulses from Established Timing Pulses. Typical of C Pulses from B and D Pulses

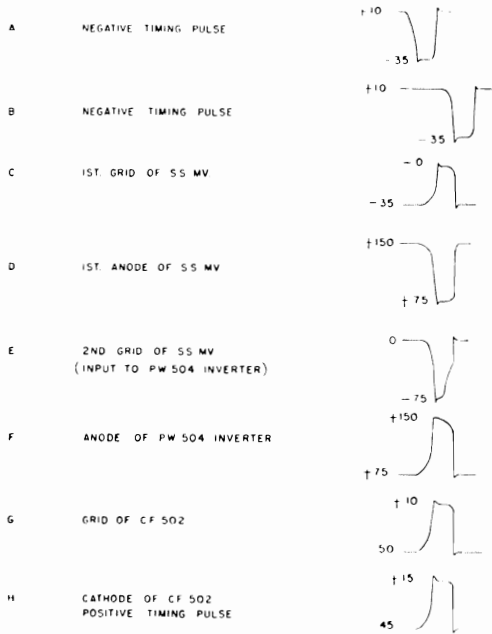
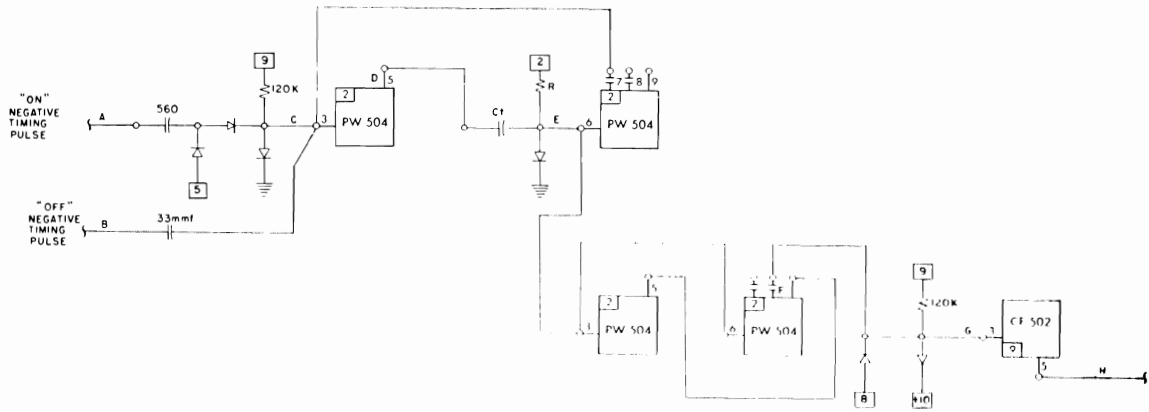

Figure II-42. Circuit for Development of Positive Timing Pulse from Other Established Timing Pulses when No Similar Negative Pulse Is Required. Typical of Write Sample Pulse

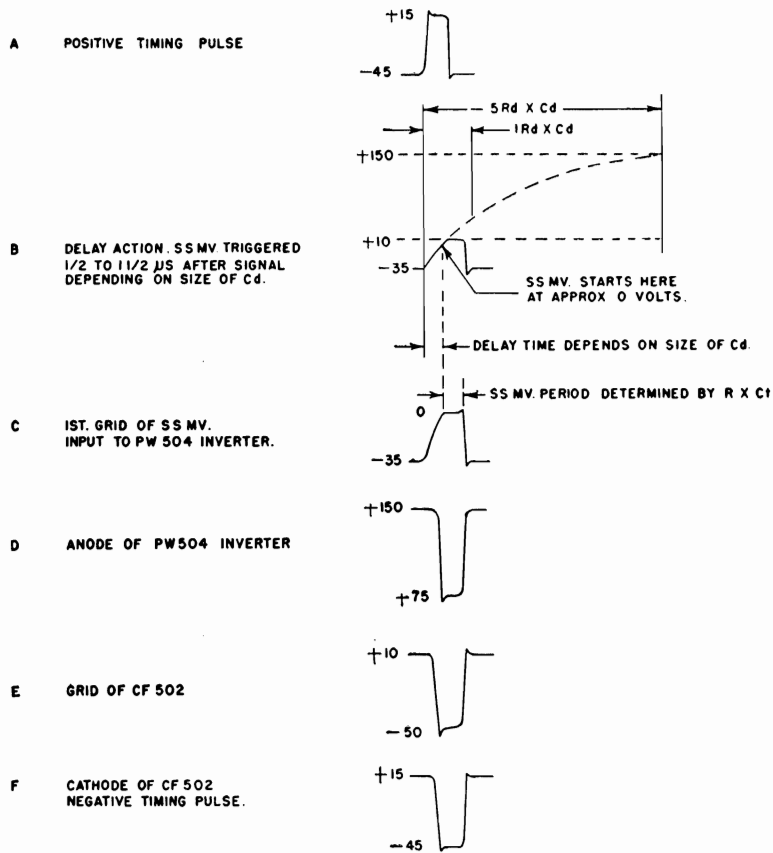
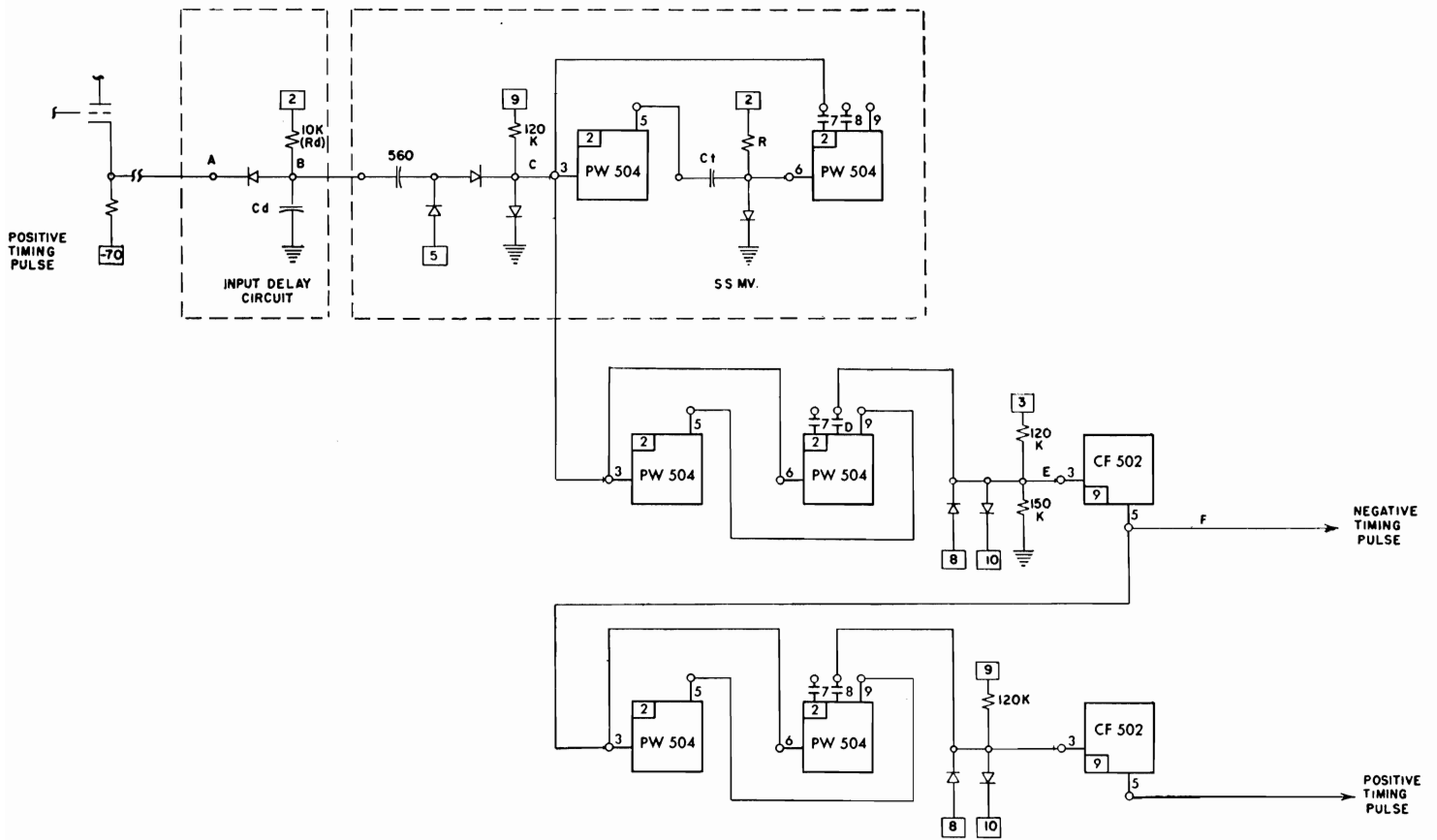

Figure II-43. Circuit to Develop Negative and Positive Timing Pulses by Delaying an Established Timing Pulse. Typical of Development of EAP from DP; AP from EAP, etc.

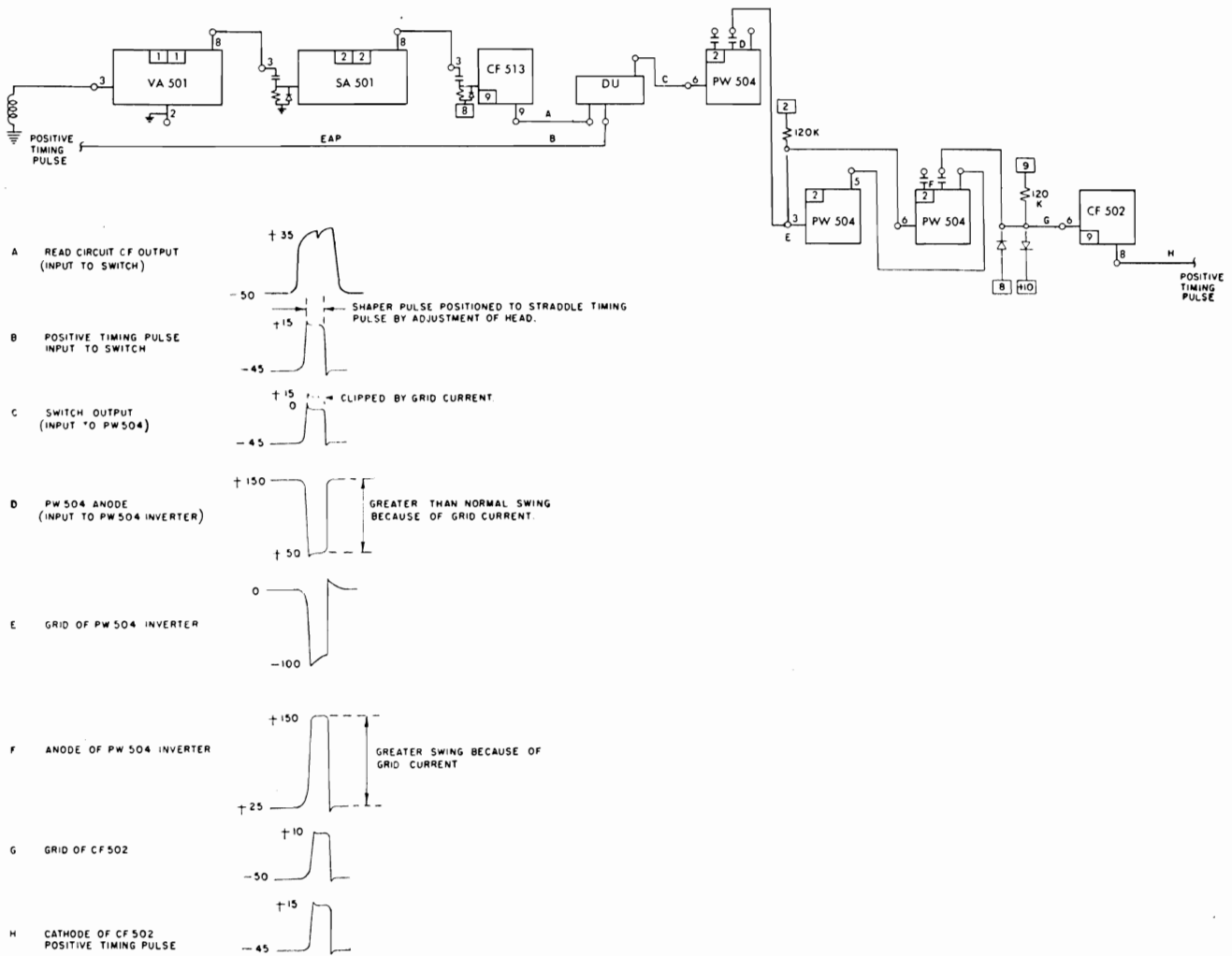

Figure II-44. Circuit for Development of Positive Timing Pulse by Switching Established Pulse with Timing Track Signal. Typical of EHP, ESP, EWP

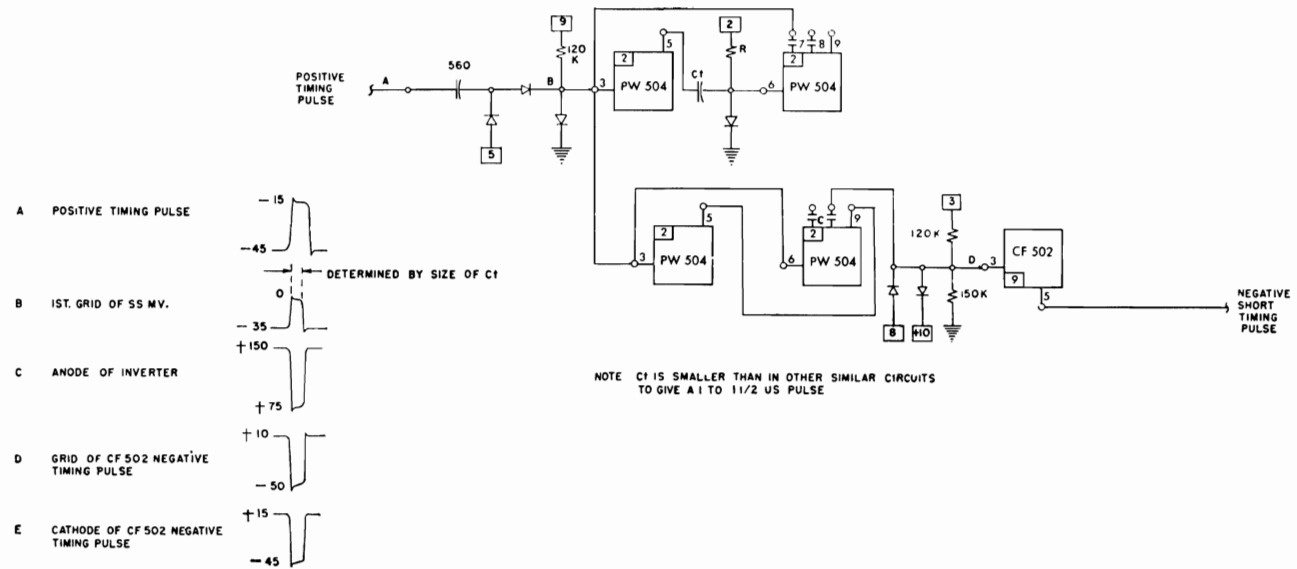

Figure II-45. Circuit for Development of Short Duration, Negative Timing Pulse from a Normal Established Pulse. Typical of Negative Latch Reset Pulse from A Pulse

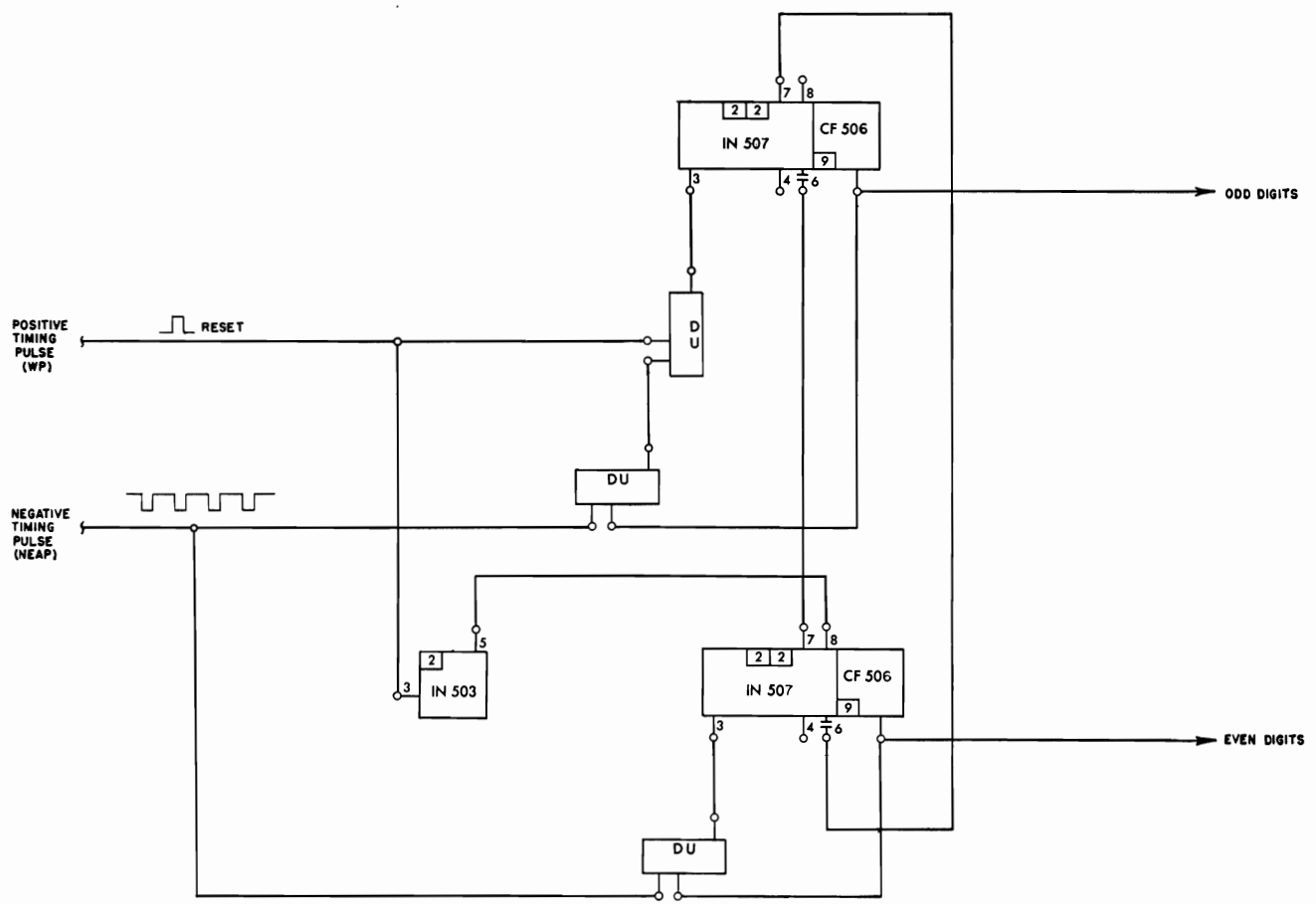

Figure II-46. Circuit to Develop Alternate Timing Gates. Typical of Odd and Even Digit Gates Using Negative Early A Pulses

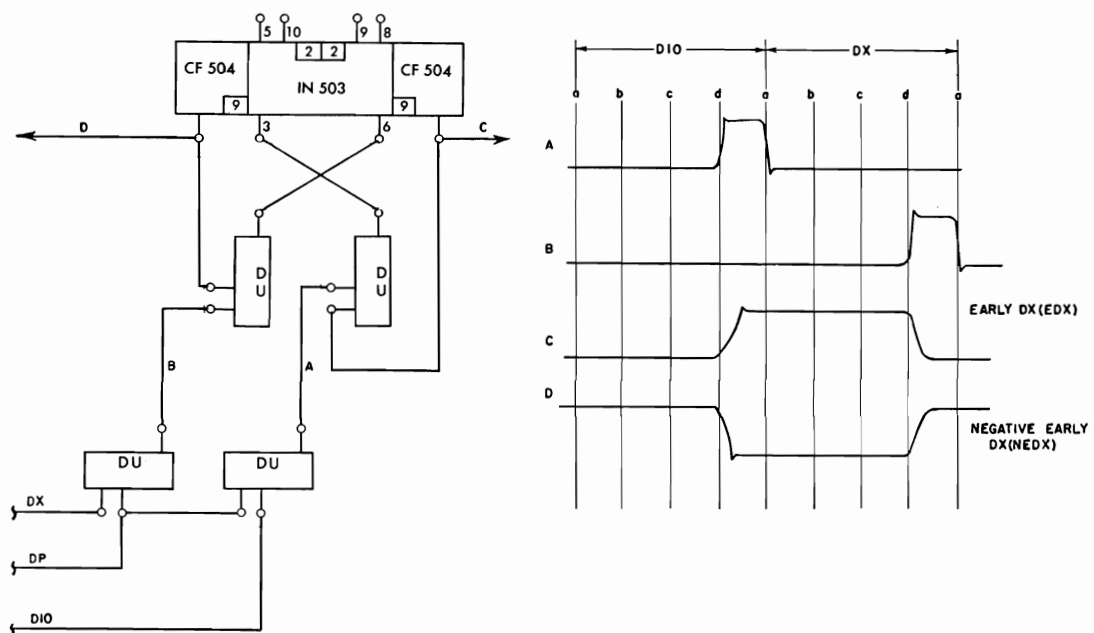

Figure II-47. Development of Special Negative and Positive Gates from Established Gates and Pulses

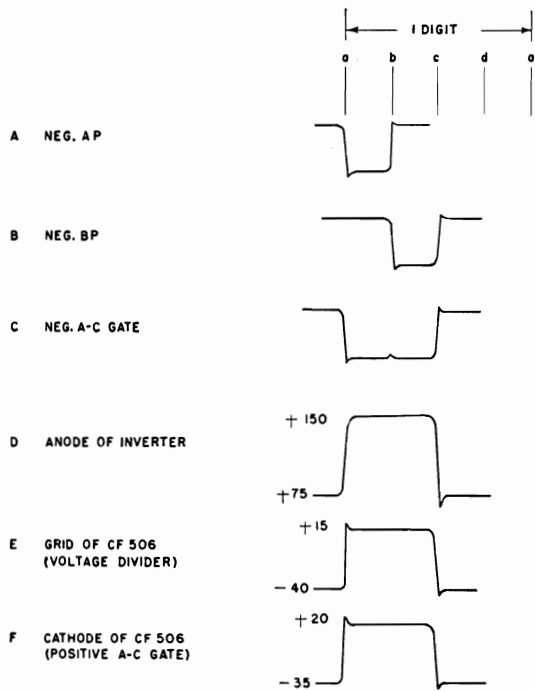
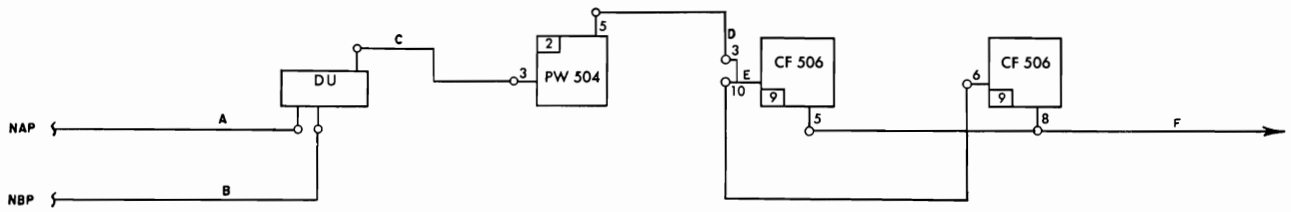

Figure II-48. Development of Special Timing Gate from Established Timing Pulses



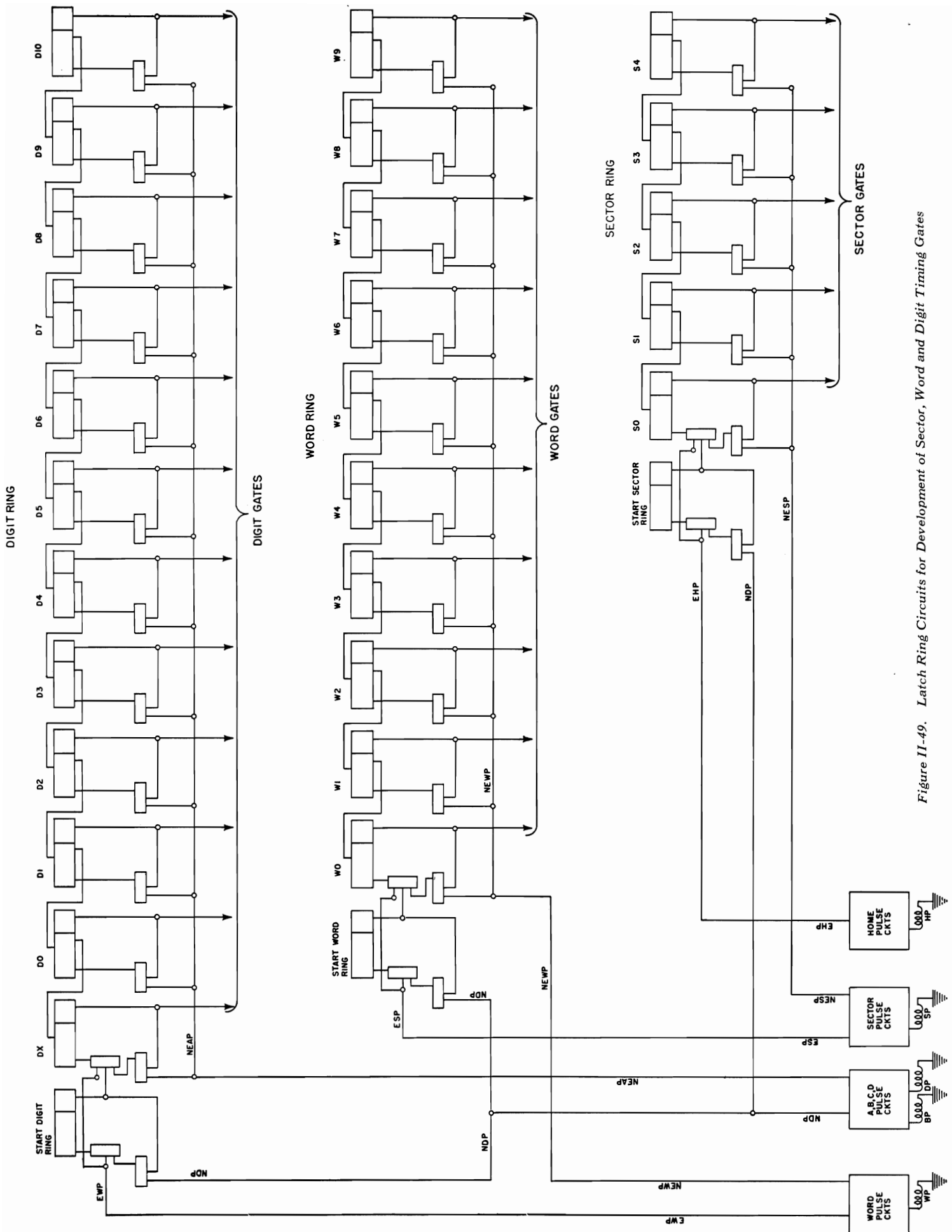

Figure II-49. Latch Ring Circuits for Development of Sector, Word and Digit Timing Gates

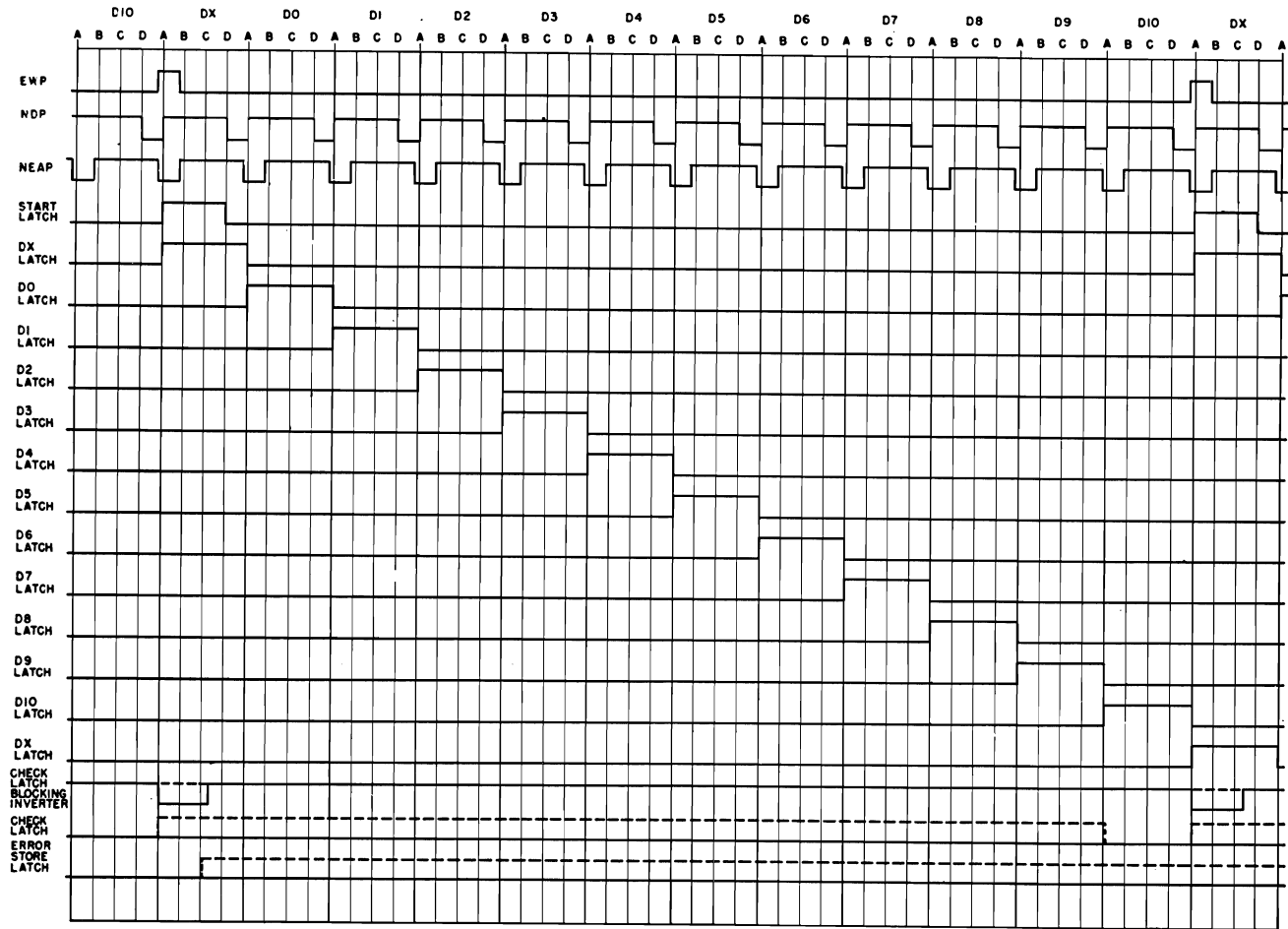

Figure II-50. Timing Chart for Digit Ring

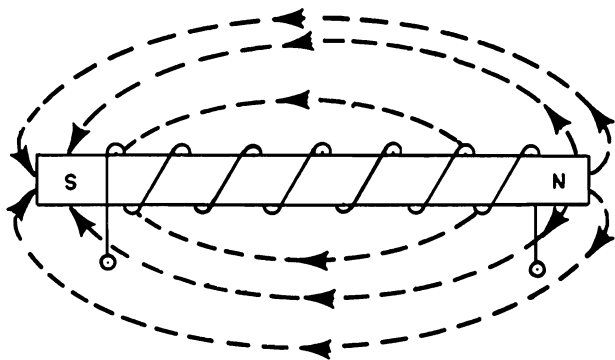

Figure II-51. Magnetic-Head Principles

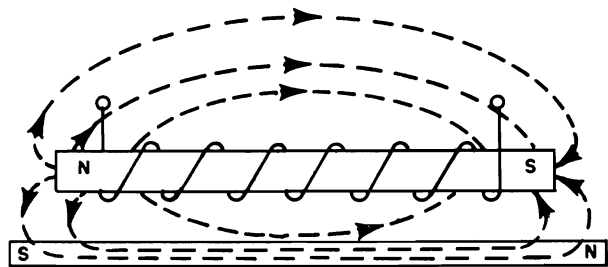

Figure II-52. Magnetic-Head Principles

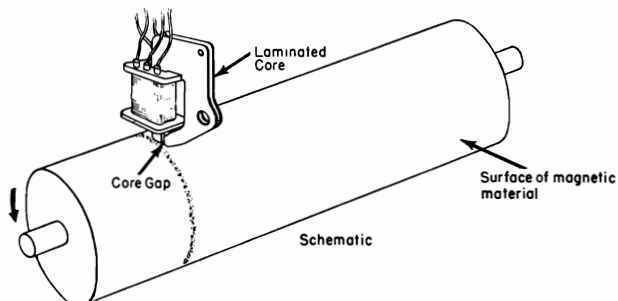

Figure II-53. Drum and Head

In Figure II-53 the electromagnet has become a recording head, and the sheet of magnetic material has been wrapped around a drum. The head is placed so that the air gap is adjacent to the drum surface. If the drum is made to revolve, bits of information in the form of current pulses can be recorded as small magnets or magnetic spots on the surface of the drum. With this arrangement the recorded spots can be packed close together. The spots are recorded serially in tracks, imaginary strips of surface the width of a head core that extend around the drum.

When writing, there is sufficient fringing of the field across the air gap between the poles to link with the surface of the drum and induce a magnetic spot (Figure II-54).

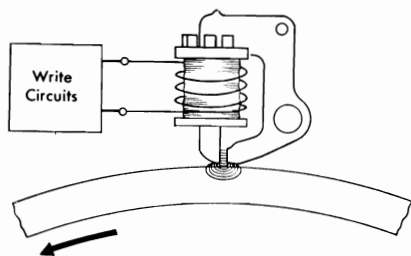

Figure II-54. Magnetic Writing Flux

With the drum revolving under the head, a ready means of getting the information back into a voltage signal form is provided. The reading out of information is dependent on the fact that a change in magnetic field intensity in the air gap will induce a voltage across the winding. Because the spot previously written on the drum surface is itself a small magnet, there is a field associated with it. As this field passes under the head, some of it fills the air gap and induces the core to become a magnet, with the result that a voltage proportional to the rate of change of flux in the core is induced across the winding (Figure II-55).

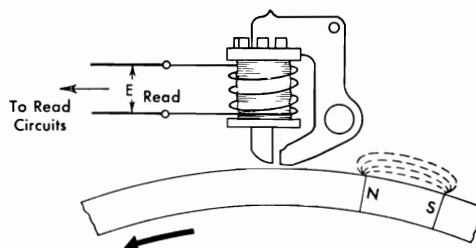

Figure II-55. Magnetic Reading Flux

The voltage induced across the winding will be sinusoidal in form, reaching maximum and minimum values when the north and south poles pass under the air gap; i.e., when the flux in the core is changing most rapidly, and falling to zero between the poles when the flux is constant. The shape of the output signal is established by the polarity of the magnetic spot, which in turn was governed by the direction of the writing current through the winding when the spot was placed on the drum. The term *writing* is taken to mean the action of placing a spot of either polarity on the drum. *Recording* and *erasing*, the two forms of writing, are used to describe the two possible polarities. A recorded spot reads back as a *down-up-down* or *negative-going* sinusoidal signal, while an erased spot reads back as an *up-down-up* or *positive-going* signal (Figure II-56).

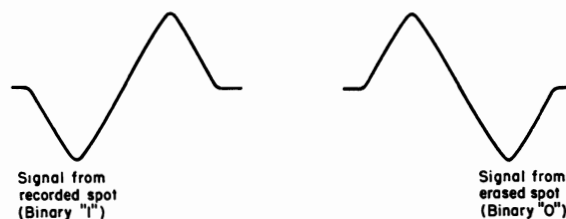

Figure II-56. Read Signals

In the parallel bit storage systems used in the 650 (bi-quinary or two-of-five) the recorded spot indicates a binary 1, while the erased spot indicates a binary 0. In the bi-quinary system, the simultaneous reading of two recorded spots and five erased spots within a digit-position interval determines the decimal value of a digit. In the two-of-five system the simultaneous reading of two recorded spots and three erased spots within a digit interval determines the digit's decimal value. Figure II-57 shows the decimal value 7 represented in each system. The magnetic-storage read circuits are arranged to detect the difference in the two types of signals.

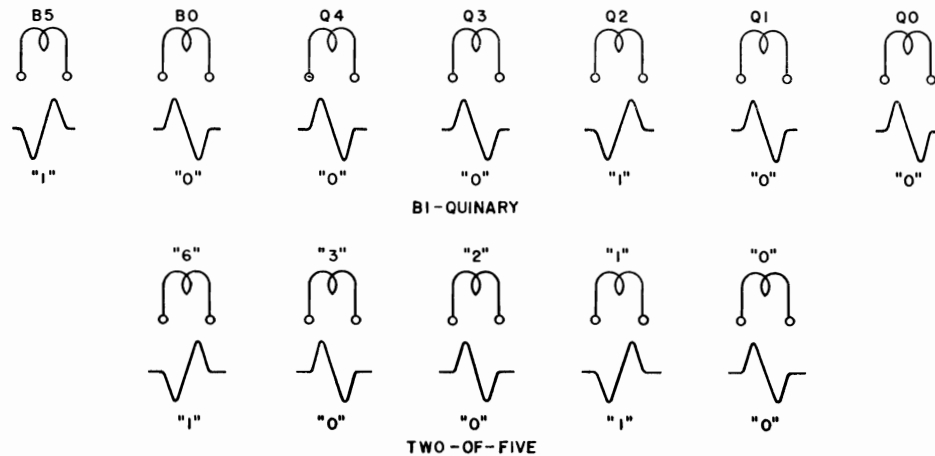

Figure II-57. Bi-Quinary and Two-of-Five Representations of Decimal 7

There are a number of factors involved in the design of a magnetic-drum storage system. There are electronic circuits associated with the heads to provide a suitable pulse for writing and to change the pulse, which is read back into a useful form. The material and dimensions of the core and the number of turns in the windings must be determined. The core gap and the head-to-drum clearance affect the shape and size of the read signal. Surface material and the speed of the surface relative to the head are important. The problems of size, total amount of storage, head selection, and access time must be considered.

The resolution of these factors into a workable system that satisfies the requirements of the 650 has resulted in the head and drum specifications.

### Drum Mechanical Features

The drum used in the 650 is pictured in Figure I-3. The mechanical features of the drum are illustrated by the drawing of Figure II-58. The entire drum and drive motor form a complete assembly. Cables leading to the heads terminate in sockets into which the individual heads are plugged.

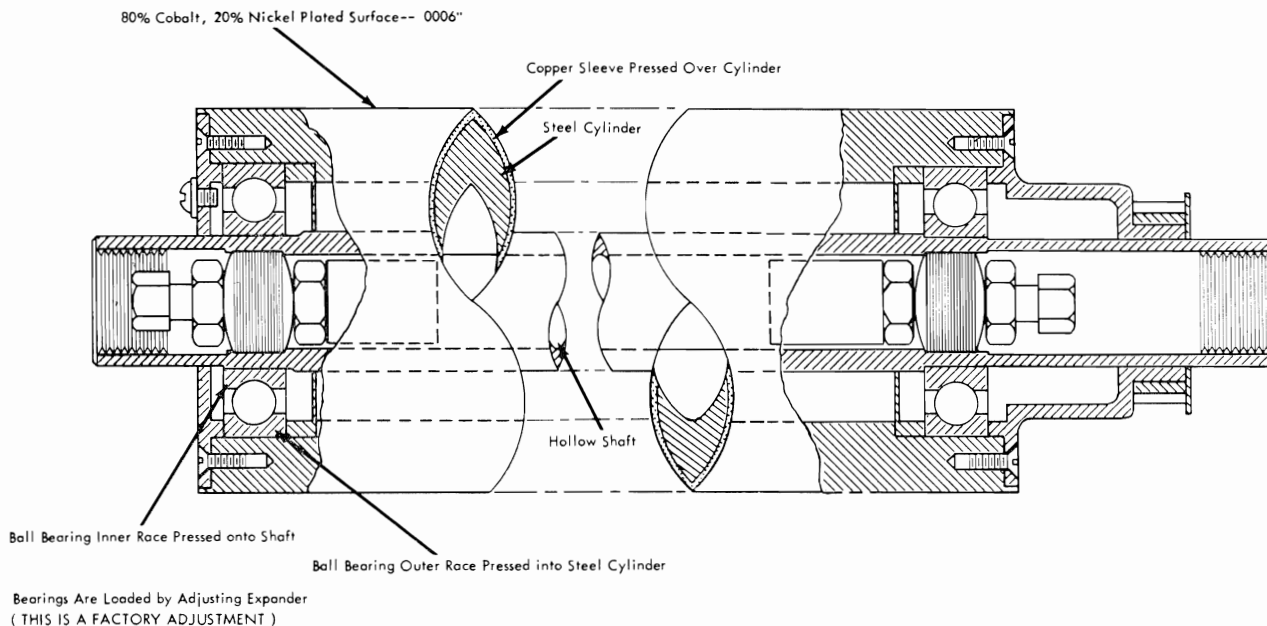
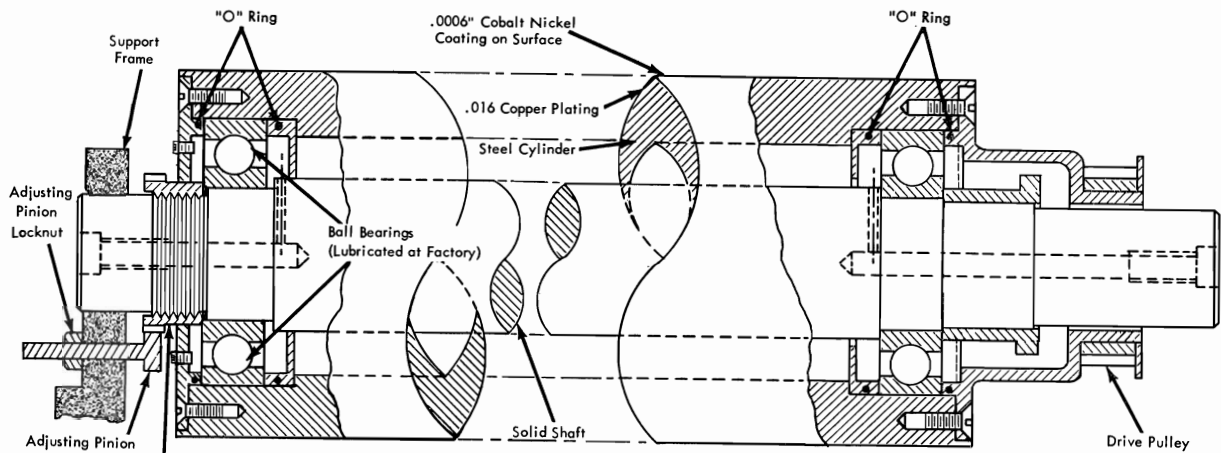

Figure II-58. Hollow Shaft Drum



Note:  
Bearing inner race  
adjusted to .0001\"/>

Figure II-59. Solid Shaft Drum

Figure II-58 shows the mechanical construction of the hollow-shaft drum used on the earlier 650 machines. This drum had expanders located inside the shaft for proper adjustment of the bearings. These expanders are adjusted for the correct pre-loading of the bearings and should not be adjusted in the field.

Figure II-59 is a view of the solid-shaft drum that is used on machines manufactured after August, 1955. This drum does not have the vibration of the hollow-shaft drum, and it is easier to manufacture. Both types of drums are dynamically balanced at the factory to reduce vibration.

The drum is driven through a cog-type timing belt on the right end by an ac induction motor. This belt should be checked for wear every thirty days and replaced if any sign of red rust or cracking appears.

**Heads for Reading and Writing**

The head used for reading and writing is shown in Figure II-60. A plastic (Micalex) housing holds the parts of the assembly. The assembly consists of a pivoted, laminated core with a hollow plastic bobbin around one side, on which are two 80-turn windings, one of which is center-tapped. A compression spring holds the core in position with its stud against the adjusting screw. The head is held to two mounting bars by the mounting screws. As the mounting screws are tightened, the tension locking clips flatten out and hold the position. This is necessary because the mounting screws are also used for adjusting purposes. The position of the head along its track can be varied by

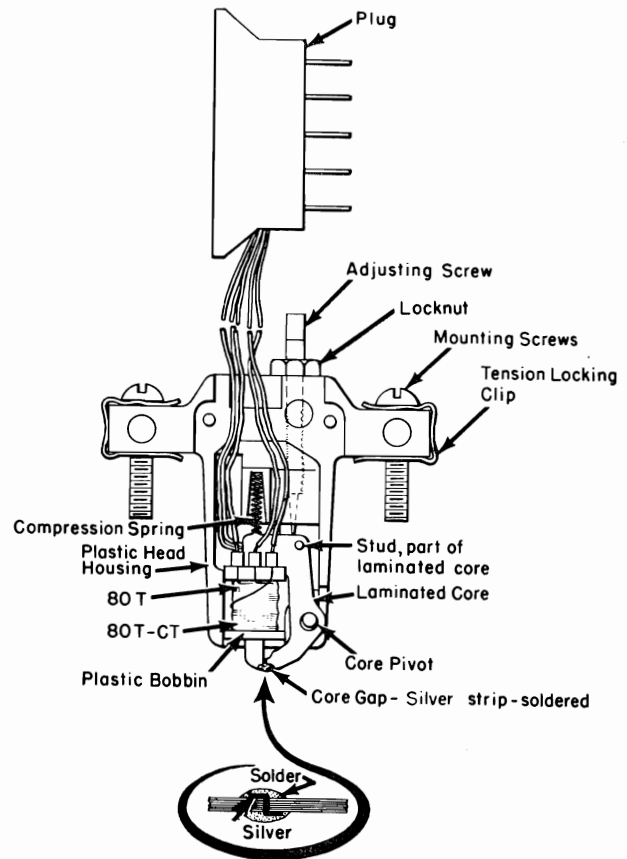

Figure II-60. 650 Magnetic-Head Assembly

more than a full-digit interval by use of these screws. Figure II-61A illustrates the adjustment obtainable by these screws.

The fine adjustment, used to obtain proper head-to-drum clearance is made by the adjusting screw C and results in the possible variation shown in Figure II-61B.

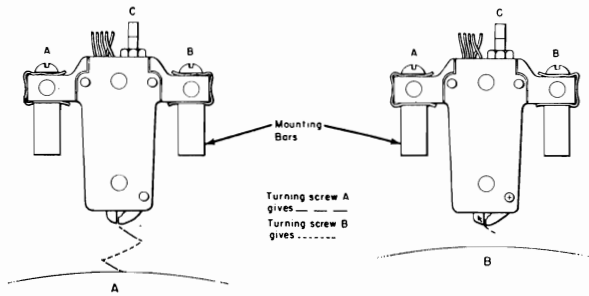

Figure II-61. Head Adjustments

Reading and Writing Principles

Two different ways of connecting the heads are used in the 650, one for the buffer storage heads and another for general storage. This is made necessary by the fact that the heads to be used on a general storage read or write operation must be selected, while the same heads are always used on any buffer storage operation. The simplified circuits of Figure II-62 and II-63 illustrate these two ways of using the heads.

Figure II-63 shows how the heads are used for buffer storage. The 80-turn center-tapped coil has its

center tap grounded to the *write common*. One end connects to the cathode of one half of a PW503 for recording, the other end to the other half of the PW503 for erasing. The other 80-turn coil is connected between ground (read common) and a VA501 grid for reading. All buffer storage write circuit ground connections are made to chassis 6 through the shield of the cable leading to the heads instead of to the drum frame. This shield return is the write common. Read circuit grounds are made in a similar way through the shield of the cable leading to the read coil that forms the read common. Chassis 6 contains the buffer storage circuit components.

Figure II-62 shows how the heads are connected for general storage use. Here the two 80-turn coils are connected and a center tap connection is made at their junction. One coil is then used to record, and the other to erase. The same coil that is used to record is also used for reading.

Figure II-64 shows the details of the head connections for buffer storage and general storage.

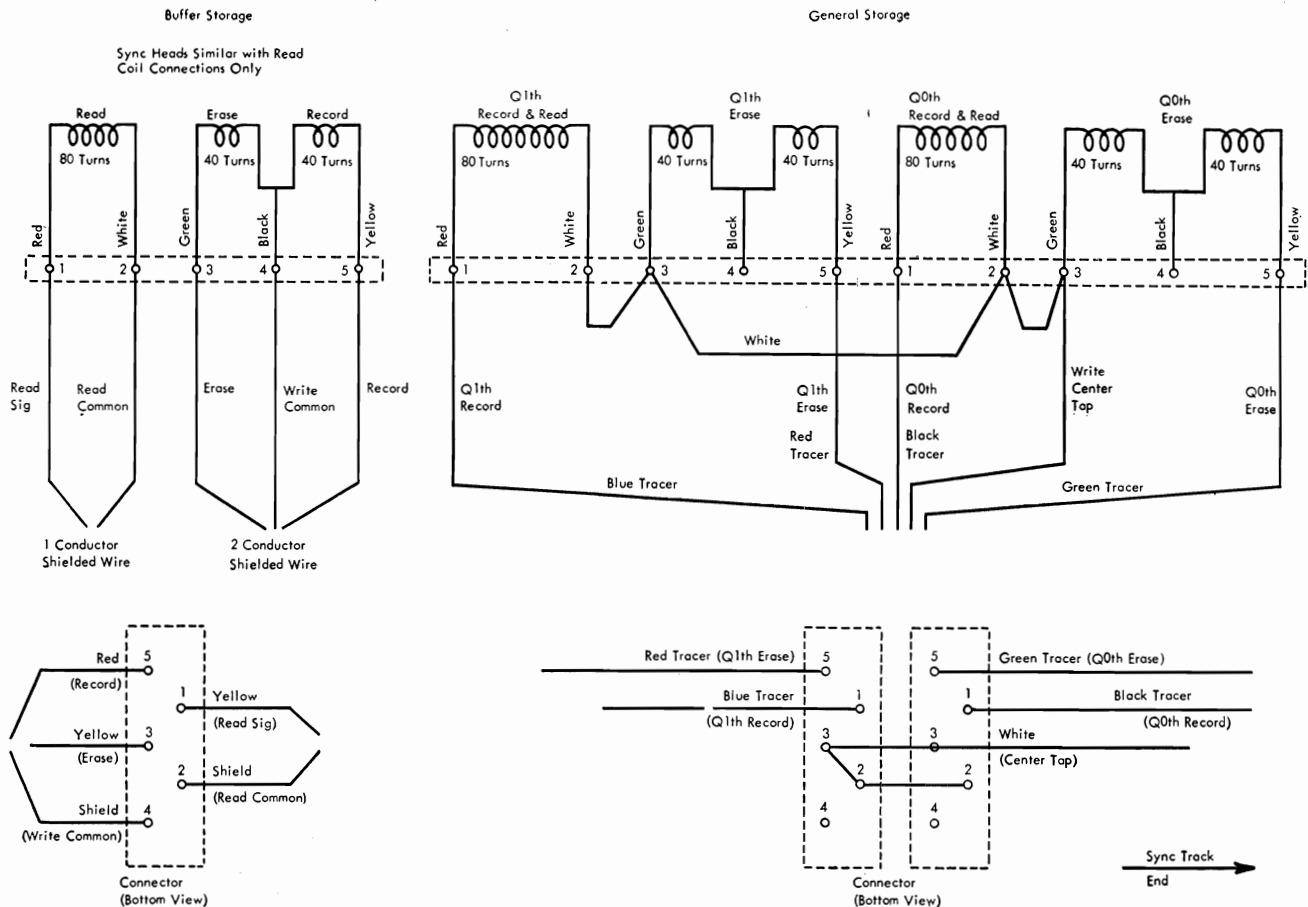

Figure II-64. Details of Head Connections

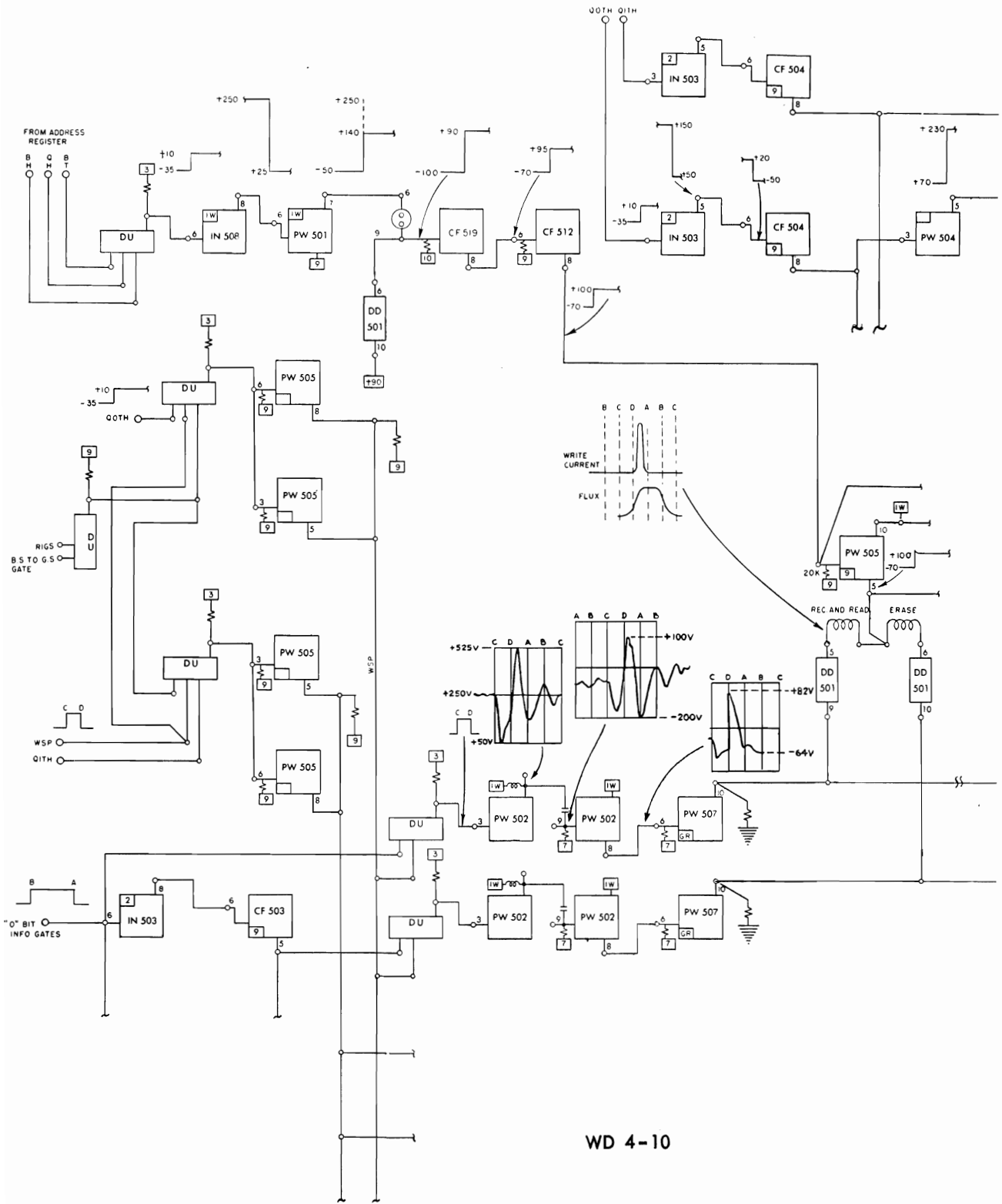
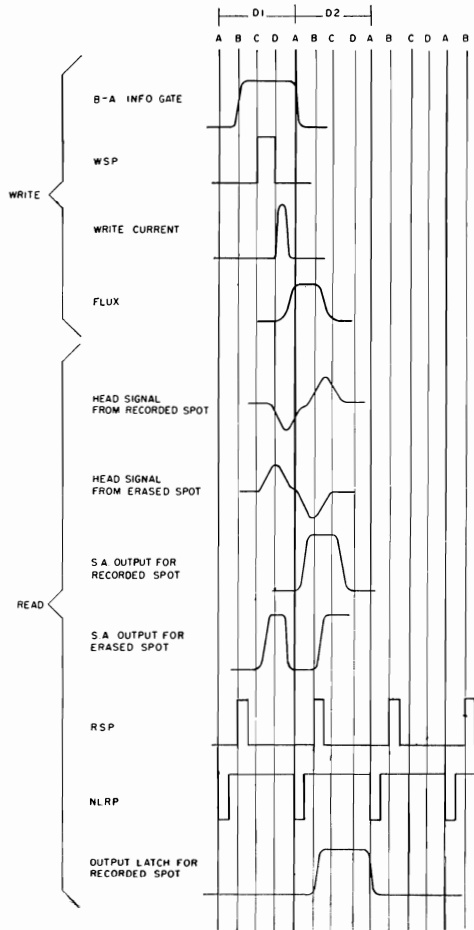
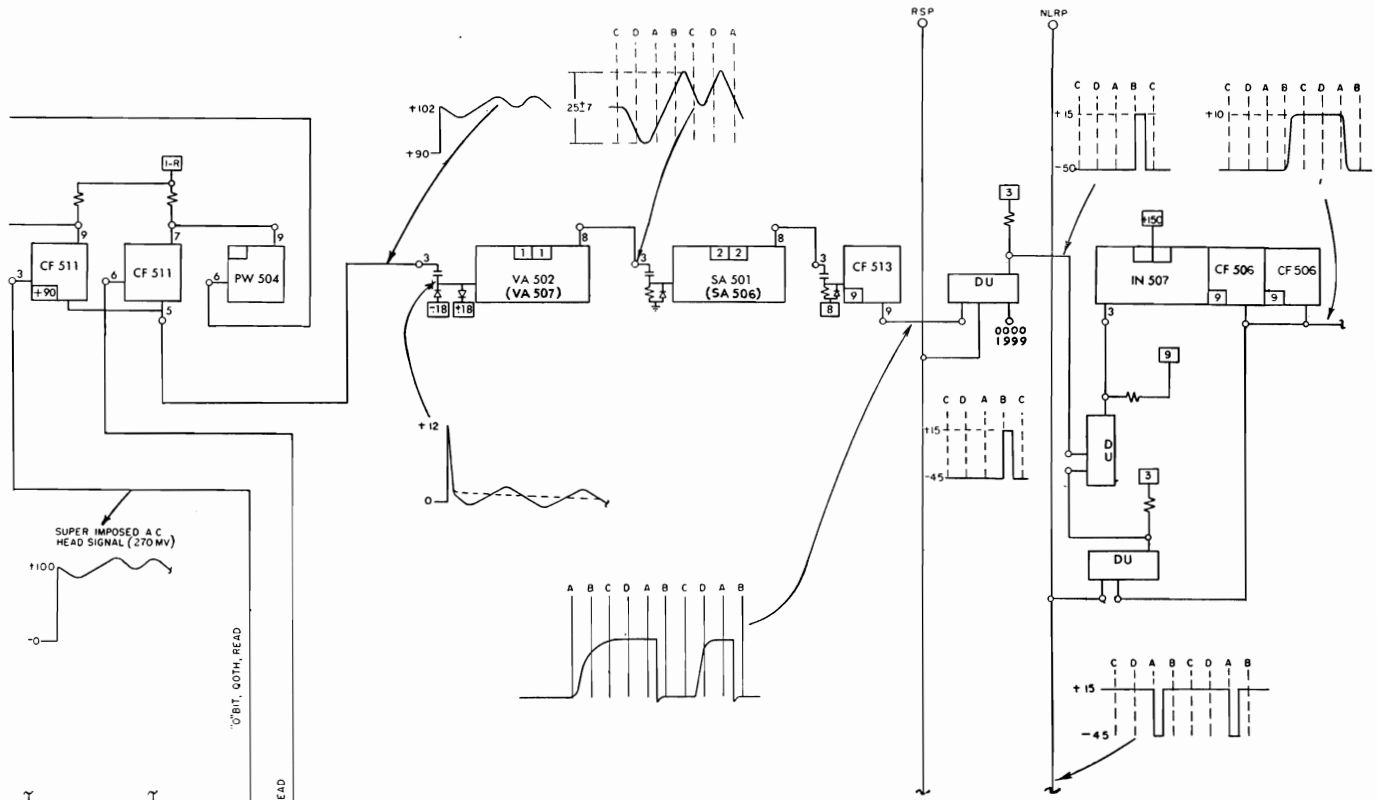
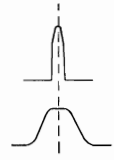

Figure II-62. General Storage Head Connection and Read-Write Circuitry



NOTE EXCEPT FOR DRUM MOTION, FLUX WOULD HAVE THIS TIME RELATION TO CURRENT.



NOTE READ HEAD SIGNAL MAXIMUM WHERE RATE OF CHANGE OF FLUX IS MAXIMUM.

NOTE RSP ONLY COINCIDES WITH S.A. OUTPUT FROM RECORDED SPOT



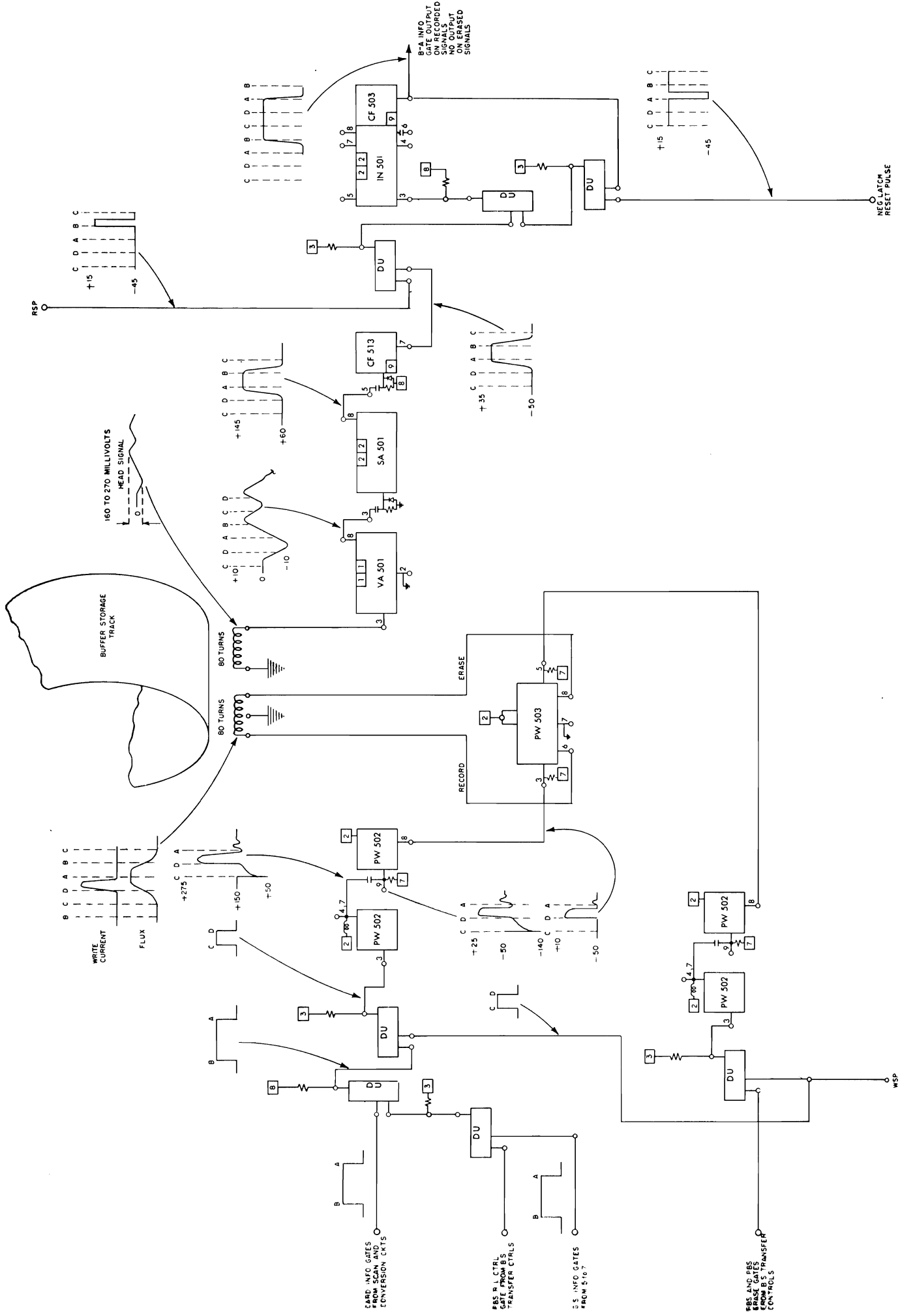

Figure II-63. Buffer Storage Head Connections and Read-Write Circuitry

The general storage circuits represented in Figure II-62 will be used to explain the principles of magnetic writing and reading.

When placing information in general storage, the object is to place the spot on the drum in such a position that when it is later read out it will cause the read circuits to produce an *on time* B-A information gate; i.e., if the spot is to represent D1, it should when read out, cause a B-A information gate to be developed during the D1 timing interval. It should be remembered that all information is transmitted throughout the machine in the form of B-A gates. Reference to Figure I-11 will show that information can be sent to general storage from either the distributor or from read buffer storage. Thus, the output from these units must be in the form of B-A information gates, which, when allowed to reach the general storage input, will actuate the write circuits.

Because time is required to write and to read, the general storage write circuits must be actuated in advance of the drum time of the digit to be stored, if the digit is later to be available from the general storage read circuits as on time B-A gates. In this machine, the magnetic storage circuits have been designed so that one whole digit time is used in the process of writing and reading. Thus, the B-A gates from either distributor or read buffer storage, which actuate the general storage write circuits, must be one-digit time early with respect to the drum time of the digit that they represent. The spots will then be placed on the drum in such a position as to cause the read circuits to put out on time B-A gates when they are read out. In other words, general storage receives information in the form of one digit early B-A gates and puts out information as on-time B-A gates.

It will be remembered that the distributor, a capacitor storage unit, has both a one-digit-early output and an on-time output. The one-digit-early output is used when information is sent from the distributor to general storage. It will be seen also that information is written in read buffer storage at such a time that it will be available from the buffer storage read circuits one digit early for proper entry into general storage.

Figure II-62 shows a part of the circuitry of the general storage read-write matrix. The outputs from the address register will have activated the selection

circuits so that the potential of the center tap will have been raised from  $-70$  volts to  $+100$  volts due to conduction of the PW505 as shown, thus readying the selected head for use. A one-digit-early, B-A gate present on one of the bit input terminals will activate the record circuit. (Only the 0 bit circuits are shown.) If the value of the digit is such that no information gate is present, this *lack-of-information* signal level is inverted, and the erase circuit will be activated instead of the record circuit.

At C time of the digit interval a write sample pulse will be present on either the Q1TH or the Q0TH line, depending on the output of the address register (assume Q0TH). This WSP will switch with the B-A gate to operate the record circuit or with the *no* B-A gate inverted to operate the erase circuit. With the trailing edge of the WSP a sharp, short voltage pulse is produced as shown by the wave forms associated with the PW502. This pulse causes the PW507 to conduct heavily for the short time of the pulse, thus energizing either the record or erase coil to place a spot on the drum. The complete circuit to energize the head is:

Ground, cathode of PW507, anode, DD501, coil, cathode of PW505, anode, 250-volt write circuit supply.

The PW507 is caused to conduct for about  $1\frac{1}{2}$  microseconds by the pulse on its grid. Write current flows through the coil during this time as shown by the wave form associated with the coil.

A timing chart showing the relation of the important factors involved in writing and reading is shown on the right end of Figure II-62. Notice that a pattern of the flux distribution on the drum surface due to the write current is shown and that the flux is slightly offset from the current. This time phase shift is due to the rapid movement of the drum surface during the current time interval. The diagram in the Note shows what the current-flux-time relationship would be if the drum were not moving.

The flux also appears to be spread over a greater time interval than the current. This is because the leakage flux around the core air gap of the head cannot be concentrated in a single point but affects an area of the surface either side of the point directly under the gap. Because of the drum motion and this

space spread, the flux effectively occupies the time interval shown. Thus, the B-A gate that activated the write circuits has produced a spot whose effect will be felt from C time of the digit interval including the above B-A gate to C time of the next digit interval. The magnetic spot on the drum surface can be thought of as occupying the space and time between two digit timing intervals. As the drum revolves, the spot and its flux pass under the head once each drum revolution, inducing a voltage across the head coils each time it passes.

The amplitude of an induced voltage is proportional to the rate at which magnetic lines of force are caused to cut across the turns of wire. Its direction is determined by the direction of the lines of force or the magnetic polarity. Figure II-65 illustrates how the flux of a magnetic spot acts on a head to induce a voltage across the windings as it passes under it. In each case the flux pattern as it would appear with and without the metal core is shown.

At position A, as the spot approaches the core gap, the amount of flux following the lower reluctance path provided by the metal core and consequently passing through the coil is increasing. The voltage in-

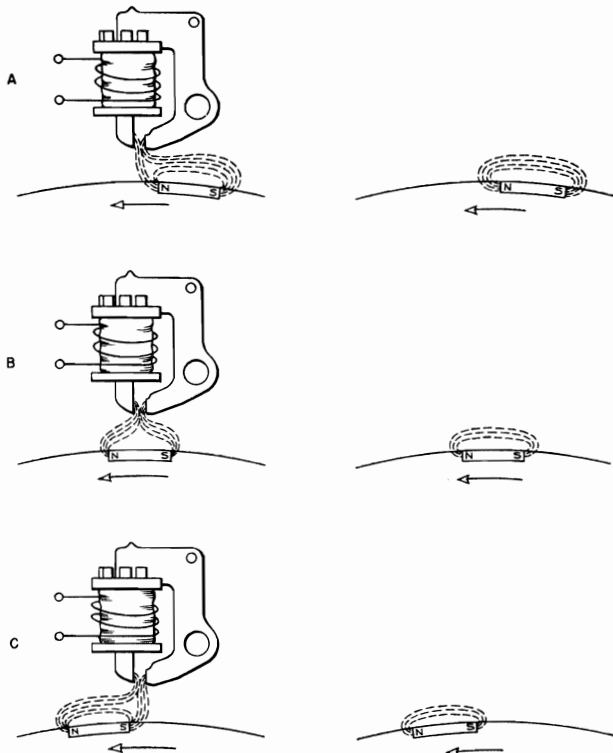

Figure II-65. Induction of Read Signal Voltage by Flux of Magnetic Spot

duced across the coil is therefore increasing. At B the amount of flux in the core has reached maximum and is *constant*. Because the flux through the coil is no longer changing, the voltage falls to zero. At C the spot is moving away from the core gap, the amount of flux through the coil is decreasing, and consequently the induced voltage is increasing in amplitude in the opposite direction. The timing chart of Figure II-62 shows the voltage produced by this action of the flux on the head. If the voltage is induced by the action of a spot of recorded polarity, it has the down-up-down shape shown, while a voltage induced by a spot of erased polarity follows the up-down-up pattern.

When it is desired to read information from general storage at some later time, it is necessary that the read circuits respond to *recorded* head signals by producing B-A gates during the digit timing interval following the one that caused the spot to be recorded. It is also necessary that the read circuits ignore signals due to erased spots. Thus, the read circuits of general storage will put out two simultaneous B-A gates, from two of the five parallel read circuits, during each digit interval whenever the address register outputs activate the selection circuits. This is in accord with the two-of-five system used for general storage.

The circuit and timing chart of Figure II-62 shows how this desired read circuit response is achieved. The address register outputs will again have selected the head by causing the PW505 to conduct, thus raising the potential of the center tap as in writing. In this case no B-A information gates are allowed to reach the write circuit input terminals and the PW507's remain cut off. Thus, when the selection is made and the PW505 conducts, parallel circuits are completed from ground, through the resistors tied to the PW507 anodes, vacuum diodes, read and erase windings, PW505 to + 250 volts.

Any induced voltages that tend to build up across the windings cancel out, and the net effect of the selection is to raise the dc level of the line to which the PW507 anodes are tied from 0 volts to about + 100 volts. This raises the dc level of the grids of the CF511's associated with the read lines to + 100 volts. Because their cathodes are returned to + 90 volts, the CF511's are conditioned for conduction.

One of the pair of CF511 triodes, whose anodes are normally blocked by action of the PW504's used as blocking inverters, will be unblocked by QTH selection from the address register. This one will conduct and drive the VA502. After the selection transient has died out, the induced ac head signal present across the read winding and superimposed on the 100-volt selection level, continues to drive the unblocked CF511 and thus becomes the input signal to the VA502. The output of the VA502 is then an amplified replica of this ac head signal.

The dc component of the VA502 output is removed by the input capacitor of the SA501, and the signal on its grid is shown by the accompanying wave form. The output of the SA501, which responds only to positive changes in the input signal, is shown by the wave form diagram and in the timing chart. The timing chart shows how the shaping amplifier responds differently to recorded and erased signals. Notice that a shaping amplifier output from a recorded signal overlaps the time of the *read sample pulse* (RSP), while that of an erased signal does not coincide. Thus, there is an RSP output from the diode switch on recorded signals and no output on erased signals. This pulse turns the output latch on at B time. The latch is reset every A time by a *negative latch reset pulse*. The output of the latch is the necessary *on-time* B-A information gate. These B-A gates pass through the 5-to-7 conversion circuits, where they are converted to the 2-of-7 bi-quinary system of digit-value representation for transmission to distributor, program register, or adder.

This action takes place continuously as long as a valid general storage address is in the address register. Information gates from a whole selected band of general storage are therefore available from the output latches. The desired series of B-A gates is selected from this train of information by the read-in switching circuitry of the unit that is to receive the information as directed by the program control circuits.

Reference to wiring diagram section 4-10 depicting the general storage read-write circuits will show that a combination of circuitry, like that of Figure II-62, accomplishes all writing into and reading from general storage.

Figure II-63 is typical of the buffer storage circuitry used to record, erase, and read. The main dif-

ference here is in the way the heads are connected. No head selection is necessary, less circuitry is needed, and the head circuits are completed to ground. Because there are fewer components in series with the head windings, less voltage is needed, and the PW502's and 503's have their anodes returned to + 150 volts instead of + 250 volts as in general storage circuits.

Information gates from the seven parallel buffer storage read circuits are continuously available from the output latches. (Only one circuit is shown.) On a read operation, a 10-word control gate coinciding in time with RBS, allows these B-A information gates to get through switches to operate the general storage write circuits, thus transferring the 10 RBS words to the selected general storage band. As soon as this transfer is complete, a similarly timed control gate (RBS erase gate) is applied to the diode switch as shown, gating through a WSP for each digit of each of the RBS words to operate the erase circuits and erase RBS to blanks. The card information gates from the cathode follower scanning matrix are then gated through to operate the record windings of RBS, by repeated usage of an RBS read-in control gate on several drum revolutions, and transfer the card information to RBS. This information will be similarly transferred to a selected general storage band on the next read operation. The foregoing control gates are developed by the buffer storage transfer and erase controls. These controls are activated by input or output operation codes.

On a punch operation a PBS erase gate that coincides in time with PBS is applied to the diode switch, gating through a WSP for each digit of each PBS word, to operate the erase circuits and erase PBS to blanks. As soon as this erasure is completed, on the next drum revolution, a similarly timed control gate (PBS read-in) is applied to diode switching as shown to allow the 5-to-7 converted B-A output gates of this portion of a selected general storage band to operate the buffer storage record circuits, thus transferring the information to be punched to PBS. The information now in PBS is then scanned out to punch by repeated usage of a PBS read-out gate on several successive drum revolutions.

The wave forms at key points of the circuits are shown and are similar to those of the general storage circuits.

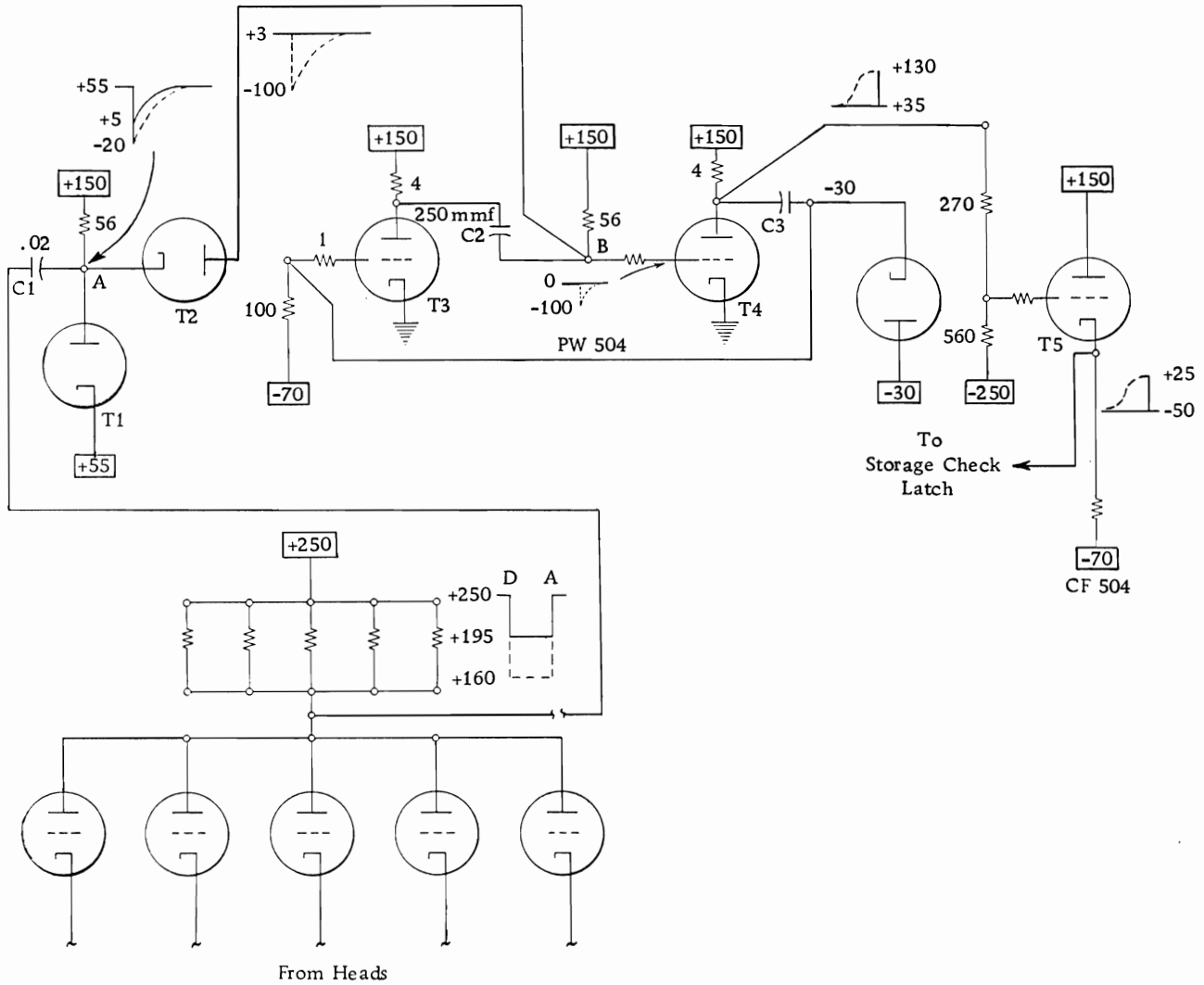

Figure II-66. Multiple Write Circuit

**MULTIPLE-WRITE—NO-WRITE CIRCUIT**

THE 650 is designed as a self-checking machine. There are circuits built into the machine for checking information as it is transferred about the machine. In order to carry the self-checking throughout the machine, there are check circuits on the magnetic-drum *write* circuits.

This checking is done by the circuit located on wiring diagram 4-10 EU. In this circuit the amount of current flowing through the heads develops a voltage across five resistors, and this voltage in turn is checked by the *multiple-write—no-write circuit*. These five resistors may be found on wiring diagrams 4-10 and 4-13.

**Multiple Write**

The multiple-write circuit (Figure II-66) is a schematic drawing of the circuit on wiring diagram 4-10EU. The purpose of the multiple-write circuit is to detect whether more than one band of heads is writing simultaneously. The sensitivity of the circuit is capable of indicating an error if seven or more heads are conducting simultaneously. The circuit samples the voltage developed across the five resistors. The normal voltage swing is about +250 to +195 volts. This is not enough change to produce an output pulse. A greater negative swing will produce a positive output pulse, which is used to turn on the storage check latch.

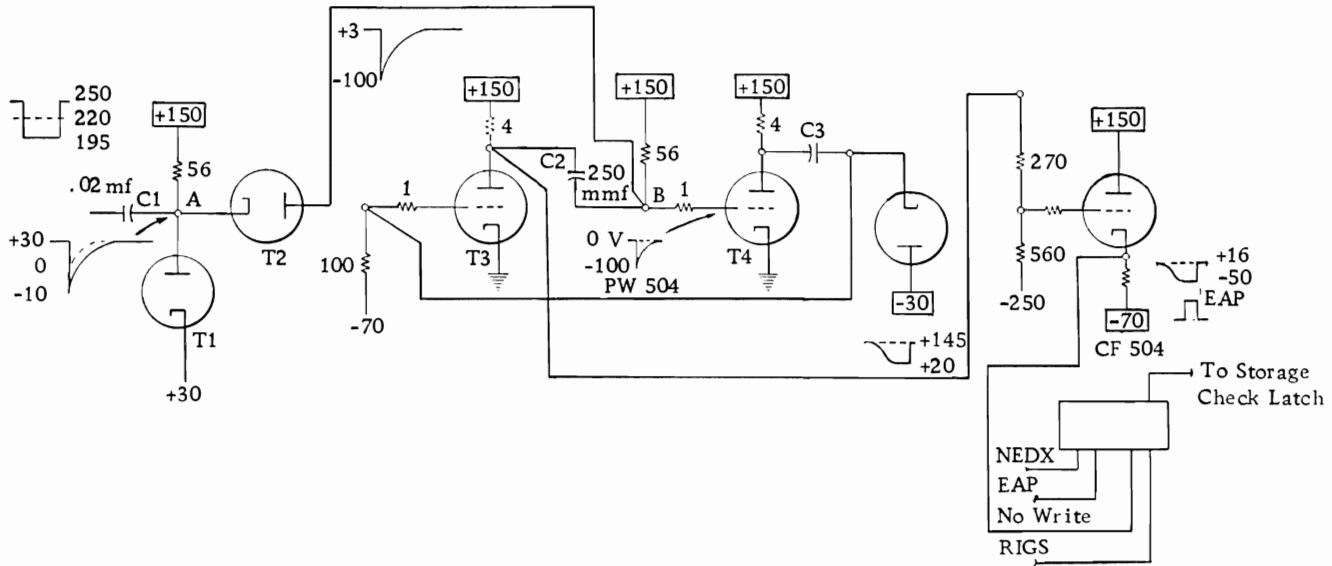

Figure II-67. No-Write Circuit

### Circuit Description

If two bands are conducting simultaneously, the negative swing across the five resistors is about +250 to +160 volts. This produces a negative spike through the coupling condenser C1 at point A. Note that point A must be driven to a potential of less than +3 volts in order for T2 to conduct. Two bands conducting simultaneously will momentarily drive point A to about -20 volts. This causes the plate of T2 to be more positive than its cathode; hence, T2 conducts. T2 conducting causes point B to swing in a negative direction, causing the plate of T4 to swing in a positive direction. This positive shift is reflected through capacitor C3, to the grid of T3. The resulting negative shift from the plate of T3 is reflected through the capacitor C2 to point B, to reinforce the original signal. This accounts for the large negative swing at point B. The output of T4 is taken through a cathode follower T5. The output of the cathode follower is used to turn on the storage check latch (WD 7-00 AU).

### No-Write Circuit

Figure II-67 is a schematic of the no-write circuit on wiring diagram 4-10EU. This circuit is for the purpose of detecting failures to write in a band on the drum. The circuit is capable of indicating an

error if three or fewer heads are conducting. The circuit samples the voltage developed across the five resistors described in the multiwrite circuit. Normal voltage swing will produce a negative output, which prevents the storage check latch from being turned on with a EAP.

### Circuit Description

During a correct writing operation, the input pulse from the five resistors causes a negative spike through capacitor C1. This causes T2 to conduct, lowering the potential at point B. The positive shift from the plate of T4 is reflected to the grid of T3. The resulting negative shift from the plate of T3 is reflected through the capacitor C2 to point B. This reinforces the original signal, accounting for the large negative swing at point B. The negative shift from the plate of T3 is also applied to a cathode follower. The cathode follower output is switched with RIGS, NEDX, and EAP. No switch output is available to turn on the storage check latch when the cathode follower output is down.

With three or fewer heads writing, the input pulse through C1 is not sufficient for T2 to conduct. Therefore, the output of the cathode follower remains up and the storage check latch is turned on with a EAP.

If the incoming pulse is not sufficient to operate the circuit owing to a failure to write, the *storage check latch* will stop the machine.

## SEVEN-TO-FIVE AND FIVE-TO-SEVEN TRANSLATOR CIRCUITS

INFORMATION from the distributor (on a store operation) or from read buffer storage (on a read operation), must be changed from its 2-of-7 bi-quinary form to the 2-of-5 system used by general storage. Also, 2-of-5 information from the general storage read-out latches must be changed back to the 2-of-7 bi-quinary form before it is sent to the selected storage line or to punch-buffer storage.

These conversions are done by the 7-to-5 and 5-to-7 translator circuits. The position of these circuits in the data flow paths is shown in WD 0-99. The circuit details are shown in section 4-00 of the wiring diagram.

The chart at the top of section 4-00 shows which pair of bits must be present, in each system, to represent each possible decimal digit value.

### Seven-to-Five Circuits

Bi-quinary output lines from the distributor and from buffer storage enter the 7-to-5 circuits in 4-00 AU. Information on either of these inputs is gated through to the 7-to-5 matrix by the presence of either a RIGS gate (developed by program control on 20 codes) or a BS to GS gate (developed by program control on a 70 code).

The chart shows that information gates on the B0 and Q0 input lines must cause similar gates to be present on the 1 and 2 output lines. B0 and Q1 gates must cause 0 and 1 outputs, etc.

Further analysis of the chart will show that several input combinations must produce gates on each of the output lines. These combinations are outlined in the following table. The 7-to-5 switch and mix circuits serve to accomplish these objectives.

Output Line	Input Conditions
0	Any Q1, B0 and Q2, B0 and Q3
1	B0 and Q0, B0 and Q1, B0 and Q4, B5 and Q2
2	Any Q0, B0 and Q2, B5 and Q3
3	Any Q4, B0 and Q3, B5 and Q0
6	B5 and Q1, or Q2 or Q3 or Q4

### Five-to-Seven Circuits

The 2-of-5 output lines from the general storage read-out latches bring information to the 5-of-7 circuits. The following table shows which input combinations must produce a gate on each output line.

Output Line	Input Conditions
Q0	2 and 1 or 3
Q1	0 and 1 or 6
Q2	2 and 0 or 6 and 1
Q3	3 and 0 or 6 and 2
Q4	3 and 1 or 6
B0	1 and 2 or 1 and 0 or 2 and 0 or 3 and 0 or 3 and 1
B5	Any 6 or 3 and 2

The 5-to-7 switches (WD 4-00 CU) are further conditioned by a negative latch reset pulse and storage control (WD 4-00 BU). The negative latch reset pulse helps to cut off the trailing edge of the 5-to-7 output gates sharply at A time. The storage control insures that there will be no general storage latch output on the selected storage line on a manual read-in to general storage operation.

## SELECTED STORAGE SWITCHING

REFERENCE to WD 0-99 shows the purpose of selected storage switching. The selected storage, bi-quinary, data flow lines that take information to distributor, program register, and adder can be supplied from any general storage band, upper or lower accumulator, distributor, or storage entry switches. It is the function of selected storage switching to gate information through to the selected storage lines from accumulator, distributor, or storage entry switches in accordance with the particular 800X address.

The details of these circuits are shown in section 5-00 of the wiring diagram.

Figure II-68 is a simplified circuit of the Q4 bit line of selected storage switching. This is a composite view of the circuits that are located on wiring diagrams 5-00, 5-10, 6-10, 6-20, and 8-00.

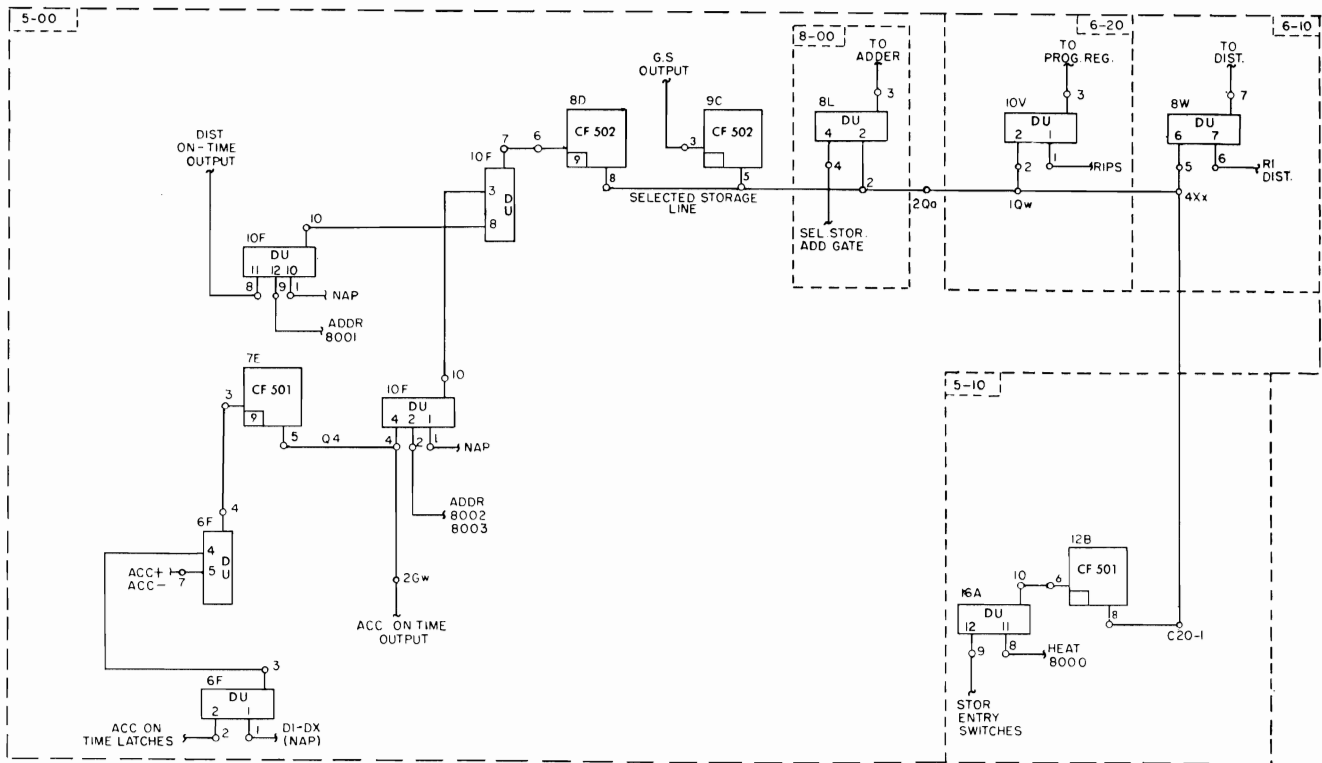

Figure II-68. Selective Storage Switching

VALIDITY CHECK CIRCUITS

Capacitor Storage Validity Check Circuits

The 650 is designed as a self-checking machine. There are circuits in the machine to keep a continuous check on the contents of the three capacitor storage units within the machine. These units are the accumulator, the program register, and the distributor.

The check circuits are designed to check the bi-quinary number system for valid information. It has been proved that practically every circuit failure will affect the valid 2-of-7 code system.

It is only necessary then to design a circuit that will check for the presence of one and *only* one binary bit and one and *only* one quinary bit at each digit time. In this manner the machine can detect extra bits or missing bits in the capacitor storage units.

Because every piece of information that enters the machine must flow through at least one of these units at some time during the course of a problem, this system will detect errors in any data of instructions handled by the machine.

In order to check for extra bits, it is necessary to check for the following bit combinations:

- |         |         |
|---------|---------|
| B0 & B5 | Q1 & Q2 |
| Q0 & Q1 | Q1 & Q3 |
| Q0 & Q2 | Q1 & Q4 |
| Q0 & Q3 | Q2 & Q3 |
| Q0 & Q4 | Q2 & Q4 |
|         | Q3 & Q4 |

A schematic of a circuit to check this is shown in Figure II-69. Any combination of the above will cause an error indication.



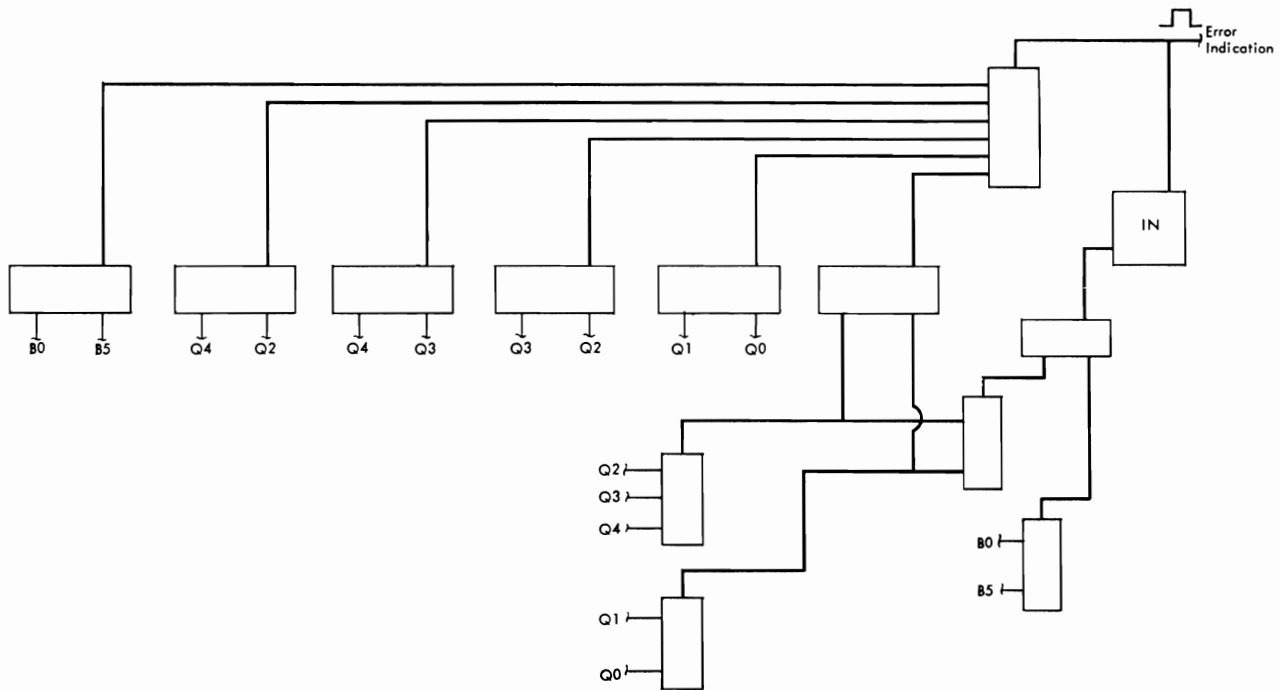

Figure II-69. Validity Check Schematic

This circuit will also check for missing bits by inverting the no-signal output from a diode switch and using that as the error indication.

Wiring diagram 6-30 shows the validity-check circuits in detail. There are three separate circuits, one for each capacitor storage unit. The output of each will turn on an error latch, which in turn will stop the machine and turn on the proper error light.

### Buffer Storage Validity Check Circuits

Buffer storage validity check circuits are being incorporated in 650 machines beginning with about 650-10489 to increase the checking features of the machine.

The checking feature is controllable from the control panel of the input-output device. The input-output device will control the checking feature for only the buffer it is using. This control is selectable between cards and consists of automatic checking circuits unless it is controlled off. The OFF position must be wired to make the checking device inoperative.

Checking is suspended for all load cards.

All ten words of input and output are checked. Therefore, if the checking feature is used, all words of input and all words of output must contain valid information.

If a failure occurs on the input from the reader, it will be detected when the information is being transferred to general storage. The storage check latch and the address selection light will be turned on. The RBS timer will be held OFF to prevent the erase of buffer storage. The reader will feed the next card, but the information from this card will not be allowed to enter buffer storage. Therefore, the reader must be cleared, and the run restarted with the error card.

If an error occurs during output scanning, a validity check latch for that particular buffer will be turned on. This latch output will set the storage check latch, turn on the storage selection light, and stop the machine the next time the output code controlling this same buffer area is used. Therefore, even though an error on the output is detected, the machine will not necessarily stop immediately.

## Example Program:

Read Code 70  
 Arith. Code ---  
 Store Code ---  
 Punch Code 71 --- Error in Punching  
 Store Code  
 Punch Code 74  
 Read Code 70  
 Arith. Code ---  
 Store Code ---  
 Punch Code 71 --- Machine Stops  
 (No erase, transfer, or punching takes place)

## Objectives:

## READ VALIDITY CHECK

The objectives of the read validity check circuits are to check the validity of the information being transferred to general storage, and if an error occurs, stop the machine, turn on the storage check latch, turn on the storage selection light, and prevent erase of the information containing the error.

## Circuits:

## READ VALIDITY CHECK (WD 6-33)

The output of buffer storage output latches switches and mixes to determine whether there is at least one binary and one quinary. The output is also switched and mixed to determine whether there is more than one binary or more than one quinary. If there is not at least one binary and one quinary or if there is more than one binary or more than one quinary, a cathode follower output will switch with ND10, DP and *RVC Timer I and II* to turn on the read validity check latch. This latch will be turned off with error reset.

The *RVC Timer I and II* is a result of switching the *BS to GS Trf. gate buffer I and II* with buffer I RBS transfer latch output to drive a cathode follower. The plate supply of this CF is a result of control panel wiring of the machine tied to buffer I (RVC not plugged).

*RVC Timer I and II* may also be a result of switching the *BS to GS Trf. gate buffer I and II* with buffer II RBS transfer latch output to drive a cathode follower. The plate supply of the CF is a result of control panel wiring of the machine tied to buffer II (RVC not plugged).

Buffer III is checked in a similar manner. The output of Buffer III is switched and mixed to determine whether there is at least one binary and one quinary, but no more than one of each. If there is an error, the output of a CF will switch with *RVC Timer III*, ND10, and DP to turn on the read validity check latch.

The *RVC Timer III* is the result of switching the *BS to GS Trf. gate buffer III* with Buffer III RBS transfer latch output to drive a cathode follower. The plate supply of this CF is the result of control panel wiring of the machine tied to buffer III (RVC not plugged).

The output of read validity check latch will immediately set the storage check latch and prevent any further restarts. The output will also switch with *Neg. RVC Timer I, II and III* to hold off the *RBS Timer* for buffer I or II and prevent the completion of the read code operation. Only the transfer (of the *transfer, erase and scan* operation) will take place. The invalid information will be held in the buffer area.

## Objectives:

## OUTPUT VALIDITY CHECK

The objectives of the output validity check circuits are to check the validity of information being punched; and if an error is detected, prevent erase of the invalid information, stop the machine, and turn on the storage check latch and storage selection light.

## Circuits:

## OUTPUT VALIDITY CHECK (WD 6-33)

The same switching circuit used to check the input validity is used to check output validity. An output validity check latch is turned on by switching the output of the check circuit with ND0, DP and *PVC Timer* (WD 6-33).

The *PVC Timer* is a gate developed for each punch (print) digit time by switching *PBS Timer* at a CF with the plate voltage determined by the control panel wiring and a timing cam (P44 on the 533) on the output device.

Because it is desirable to check validity during punching (printing), and use the operation register to indicate the error buffer, three output validity check latches are used. When an output validity error occurs, the output device is in its output cycle.

The error turns on the corresponding output validity check latch. The control commutator restart will have previously taken place. Therefore, the control commutator cannot be held up at this time. The validity check latch prevents the associated output code latch from turning on, and turns on the storage check latch, when the operation register calls for the next output code associated with the error buffer.

The output validity check latch is reset from the error reset line.

### 533 Read Validity Check Circuits

The RVC circuits in the 533 are controlled by R214 (28A). The R214-2N/C (27A) point will provide plate voltage to the CF507 at 4M (3-30B). Plate voltage at this CF will allow the *RVC Timer* gate to be developed. *RVC Timer* gate is necessary to turn on the read buffer check latch if an error occurs.

To make the checking operation inoperative, R214 must be picked. This may be accomplished by wiring RVC OFF; or by R260-12N/O point on load cards.

Digit impulses through R26 and 27 will pick R214. The hold circuit is through R8 until 352°.

Validity will not be checked on run-in. Read codes are necessary for the checking operation and do not occur on run-in.

### 533 Punch Validity Check Circuits

The punch validity check circuits on the 533 are controlled by R215 (3B). The R215-2N/C (6A) point will provide plate voltage to the CF 507 at 3P (3-30C). Plate voltage at this CF will allow the PVC Timer to be developed. PVC Timer is necessary to turn on the output validity check latch.

To make the checking operation inoperative, R215 must be picked. This may be accomplished by wiring PVC-OFF. If PVC-OFF is wired, R215 will be picked and held from 13.8 to 9.3.

The hubs are located as follows on the 533 Control panel:

RVC	OFF	AR 43 and 44
PVC	OFF	AR 45 and 46

# SECTION III. 650 CONSOLE UNIT

## PROGRAM CONTROL UNITS

THE program controls consist of the following:

1. Program register
2. Address register
3. Operation code register
4. Dynamic selection circuits
5. Control commutator and operation code analysis circuits
6. Address selection switches, control switches and keys on the control console

### The Program Register

The program register, sometimes called program step storage, is a 10-digit capacitor storage unit similar to the distributor. It consists of a 10-digit capacitor storage matrix with positions for storage of digits 1 through 10 (no sign is stored), even- and odd-digit amplifiers and blocking inverters, early latches, on-time latches, pedestal cathode followers, entry switching and read-in, regeneration, and reset controls.

The program register circuits are shown on WD 6-20. Figure III-1 shows the data flow.

#### Regeneration (Figure III-2)

As in the distributor, one-digit-early capacitor read-out spikes from two of the seven capacitors in a digit column drive the even- or odd-digit amplifiers, causing the corresponding early latches to be turned on. These latches are normally turned off at the end of the early-digit time by inverted AP, and while ON provide the program register early output. The early latches in going off cause the corresponding on-time latches to be turned on through capacitor-coupled inverters. The on-time latches remain on until the next A time through a latch back circuit controlled by NAP, and while ON provide the program register on-time output.

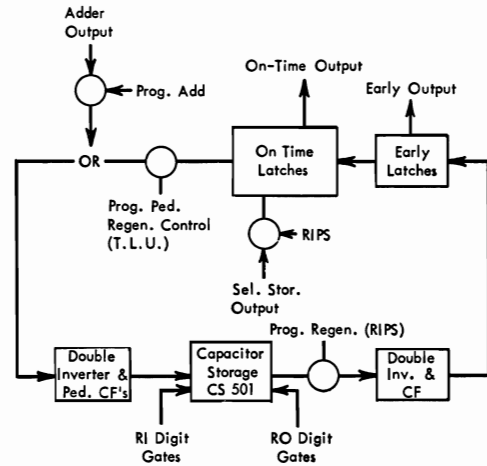

Figure III-1. Data Flow for Program Register

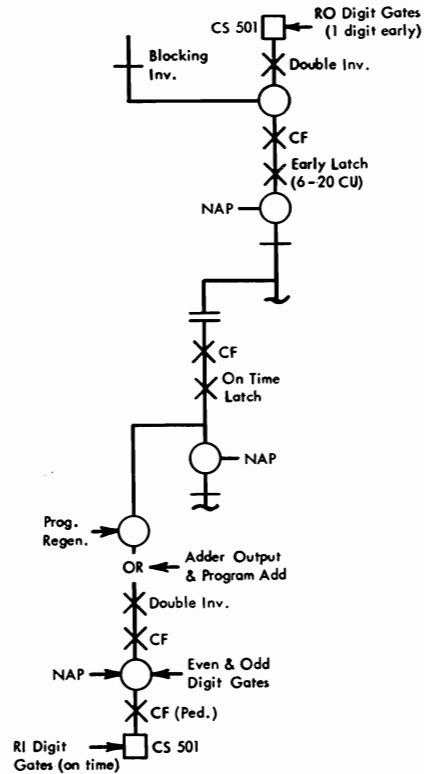

Figure III-2. Regeneration of Program Register

The outputs of these latches also switch with a program pedestal regeneration gate (except when negative during a TLU operation) to drive amplifiers whose outputs switch with NAP and even- or odd-digit gates as the case may be, to operate the pedestal cathode followers. The output of these on-time amplifiers is also the input to the address register. Thus, as long as the even- and odd-digit amplifier blocking inverters are not held in conduction and the program pedestal regeneration gate is open, a circulating regeneration path is possible whereby the stored information is continuously regenerated and made available from the early and on-time outputs.

Note from the wiring diagram that the switch, cathode follower, and inverter driving circuits in the lower section of WD 6-20 which provide the read-out and read-in gates also drive the distributor.

#### Function

The primary function of the program register is to receive and store an instruction word from a selected storage location and make the operation, data, and instruction portions of this word quickly available to the operation and address registers for interpretation. During TLU operations, the data portion of the instruction word in the program register is altered by merging the contents of the program register with special digits, in the adder, and storing the altered word back in the program register.

Thus, the program register can be read into from two sources:

1. Selected storage on a control commutator I half cycle.
2. The adder during TLU operations.

Two separate sets of program register read-in and regeneration controls are provided for these two conditions (Figure III-1).

1. On a program register read-in from selected storage (RIPS), program register read-in switching and regeneration blocking are accomplished in the same manner as for the distributor. The RIPS latch on WD 6-20 BU is turned ON by a signal from program control at the beginning of the word time when the selected storage location is in position to read-out. The output of this RIPS latch opens the read-in switching (selected storage output) to the on-time latches and turns ON a program regeneration control

latch (CL) whose output blocks regeneration by holding the even- and odd-digit amplifier blocking inverters in conduction. Both the read-in program step and program regeneration control latches are turned off with the next WP, through a reset inverter at 4W (CL).

2. During TLU operations, regeneration cannot be blocked between the matrix and the early latches because a program register early output is needed for entry into the adder. Instead, the path between the on-time latch outputs and the pedestal cathode followers is opened and on-time information from the adder output is substituted. This is accomplished by the program pedestal regeneration and program add gates and the associated switches and mixes shown on WD 6-20 AU. These gates are the output of separate program pedestal regeneration and program add latches, which are part of the arithmetic control circuits.

All digit positions of the program register are reset to zeros when the manual program reset gate is developed. This gate is developed whenever either the program reset key or the computer reset key on the control console is depressed. This resetting is accomplished by the reset inverters shown on WD 6-20 BU. They are associated with the B5, Q1, Q2, Q3, and Q4 on-time latches and the extra mix diodes in the input circuits of the B0 and Q0 latches. This circuitry holds the B0 and Q0 latches ON and holds the others OFF during the manual program reset gate duration. Regeneration is not interrupted during reset; therefore, the B0 and Q0 lines are pedestalled for each digit interval, resulting in zeros being placed in each digit position.

#### Operation and Address Registers

The operation and address registers are static storage registers with two-digit and four-digit capacities respectively. Their function is to receive the operation code and address portions of the instruction word and to make this information available to the program control, arithmetic control, and head selection circuits.

It will be recalled from a previous description of how the machine cycles through a program step, that the new instruction word is read into the program register during an I half cycle of the control com-

mutator. A back signal from the program register then advances the control commutator to its beginning position by causing the *restart B* latch to be turned on. This latch will remain on for one word interval. It is during this interval that the operation and data or the instruction positions of the instruction word are transferred to the operation and address registers. As the restart B latch is turned on, the *alternation control* flip-flop latch is transferred to indicate whether this is the start of a D or an I half cycle. A restart caused by a program register back signal will always be a restart to D. During this restart word interval, the operation code must be read into the operation code register and the D-address into the address register.

During a word interval following a restart to I the I-address must be read into the address register.

During a TLU operation the D-address must be altered and stored in the address register.

Figure III-3 and WD 0-99 show a data flow path from the program register to the operation and address register and read-in switching for the operation and address registers. On a D half cycle it is necessary that this entry switching be open for D5 through D10, the times at which the D-address and operation code digits are available from the program register. On an I half cycle, the entry switching must be open for D1 through D4 when the I-address digits are available from the program register. During TLU the entry switching must be open for D5 through D10, when the general storage search is changed from one band to the next.

### The Address Register

The address register, shown on WD 7-00, consists of four digit positions of bi-quinary latch storage. The RI-address register signal (developed on WD 7-20A) that occurs for D5-DX of a D alternation and D1-D5 of an I alternation, is further switched at the entry to each position of the address register. This switching provides a D1 or D5 CP to the entry switches of the units position latches, D2 or D6 CP to the ten's position, D3 or D7 to the hundred's and D4 and D8 to the thousands; depending on whether an I or D half cycle is being performed.

Input to the address register is from the pedestal amplifiers of the program register. These seven, bi-quinary input lines are shown at the left end of WD 7-00AL. Each line connects to its associated bi-quinary latch of each position of the register. Thus a D-address of 1746 would be available as gates on the B5-Q1 lines at D5 time and B0-Q4 lines at D6 time, B5-Q2 lines at D7 time and B0-Q1 lines at D8 time. These gates would cause the B5-Q1 units position latches to turn on, the B0-Q4 ten's latches, the B5-Q2 hundreds latches and the B0-Q1 thousands latches. An I-address of 1746 would be available as program step pedestal gates on the B5-Q1 lines at D1 time, B0-Q4 lines at D2 time, B5-Q2 lines at D3 time, and B0-Q1 lines at D4 time. These gates would cause the same latches to be turned on.

It will be recalled from the section describing the control console and its uses that the address register may be reset to two different values. When the control switch is set to *MANUAL*, depression of either the computer or the program reset key will reset the address register to blanks. If, however, the control switch is in the *RUN* or *ADDRESS STOP* position, the address register will reset to 8000. This is accomplished by dividing the address register latches into two groups, those which are on to represent an 8000 address and those which are not. The resets of these two groups are separately controlled. A *set 8000* signal, which turns the latches in the 8000 group on, is provided whenever the control switch is in the *RUN* or *ADDRESS STOP* position. The two reset circuits and their latches are shown in the lower right of WD 7-00. The *reset 8000* latch is turned on by any restart, by a TLU band change signal at D1 time or

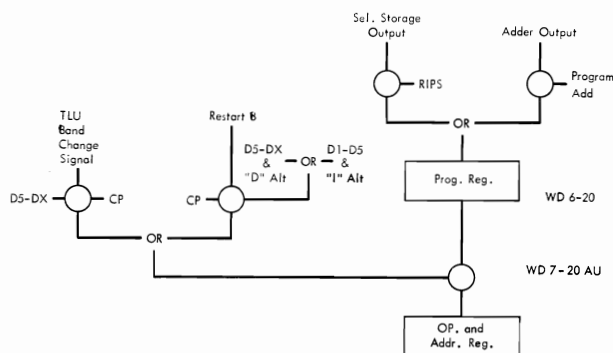

Figure III-3. Read-In Operation and Address Registers

by either reset key when the control switch is in MANUAL. When it is on, it resets the 8000 latches OFF. The *reset except 8000* latch is turned ON by any restart, by a TLU band change signal at D1 time, or by either reset key regardless of the setting of the control switch. When it is on, it resets all latches off except those which represent 8000. In those cases where both reset latches are turned ON, the register is reset to blanks. When the control switch is not in the MANUAL position, the *manual operate-reset* signal is not developed and the reset 8000 latch is NOT turned on. Instead, the set 8000 signal is developed, and the 8000 latches are turned on. The set 8000 signal enters WD 7-00AL at terminal Vd.

The following table summarizes the address register resets.

Control Switch Manual—Reset to Blanks

Control Switch Run or Address Stop—Reset to 8000

RESET 8000 SIGNAL

Resets:

- |  |   |                                    |
|--|---|------------------------------------|
| <ul style="list-style-type: none"> <li>1. B5, Q3 Thous.</li> <li>2. B0, Q0 Hund.</li> <li>3. B0, Q0 Tens</li> <li>4. B0, Q0 Units</li> </ul> | } | All latches used to represent 8000 |
|--|---|------------------------------------|

Caused by:

- 1. Any restart
- 2. Control switch *manual* and computer or program reset keys depressed.
- 3. TLU band change signal at D1 time

RESET EXCEPT 8000 SIGNAL

Resets:

- |   |   |   |
|---|---|---|
| <ul style="list-style-type: none"> <li>1. B0, Q0, Q1, Q2, Q4 Thous.</li> <li>2. B5, Q1, Q2, Q3, Q4 Hund.</li> <li>3. B5, Q1, Q2, Q3, Q4, Tens</li> <li>4. B5, Q1, Q2, Q3, Q4 Units</li> </ul> | } | All latches except those used to represent 8000 |
|---|---|---|

Caused by:

- 1. Any restart
- 2. Computer or program reset keys regardless of control switch position
- 3. TLU band change signal at D1 time

SET 8000 SIGNAL

Turns on:

- |  |   |  |
|--|---|--|
| <ul style="list-style-type: none"> <li>1. B5, Q3 Thous.</li> <li>2. B0, Q0 Hund.</li> <li>3. B0, Q0 Tens</li> <li>4. B0, Q0 Units</li> </ul> | } | All latches used to represent 8000<br>Caused by: |
|--|---|--|

- 1. Control switch in RUN or ADDRESS STOP position and computer or program reset keys depressed.

The address register latch outputs are shown along the top of WD 7-00. Also shown in the BU section are special switching circuits that provide gates to indicate when the contents of the register is 8000, 8001, 8002, or 8003 for use by the program control circuits.

Check circuits associated with the address register are shown in 7-00AU. These are provided to check the validity of the address in the register. They check the thousands position for presence of any digit value other than 0, 1, or 8. If any other value is found, the storage check double latch is turned on. This turns on the storage selection light on the control console and lowers the invalid address interlock line, removing one of the conditions necessary for a restart of the control commutator and thus stopping calculation. The storage check latch is reset only by a depression of the error reset key.

When the thousands position is 8, a further check of the hundreds, tens, and units position is made to insure that they are 0, 0, and below 5, respectively.

These circuits are straightforward and will not be explained in detail except to point out the reason for the negative reset except 8000 gate. When a reset to 8000 operation occurs, the B5-Q3 Th, B0-Q0 H, B0-Q0 T, and B0-Q0 Un latches are turned on. Variations in the time required for the proper latches to turn on could allow a voltage spike to turn on the storage check latch. The negative reset except 8000 gate prevents the test from being made until the latches have had time to turn on.

The outputs from the thousands, hundreds, and binary tens latches are taken to the general storage read-write matrix where they control the static selection of one of the 40 bands, for reading or writing. The outputs from the quinary tens, and both binary and

quinary units are used by the dynamic selection circuits shown on WD 7-00 CU to select the proper word interval within the statically selected band.

#### The Operation Code Register

The operation code register is a two-digit, bi-quinary storage register. Each digit position has seven latches, one for each bi-quinary bit. Input to the register is from the seven pedestal amplifiers of the program register. These seven input lines are shown on the right end of WD 7-20 C. Two-of-seven, bi-quinary, B-A gates, representative of the digit value in one position of the program register are present on these seven lines at each digit time. The Q0 line feeds the input switches of the units and tens Q0 latches. The Q1 line feeds the Q1 latches, etc.

The operation and address register read-in signal, explained above, is further switched at the entry to the operation code register with a D10 and a CP to condition entry to the tens position latches and with D9 and a CP for entry into the units position latches. Thus, the units position will receive only the D9 output from the program register, while the tens position will receive only D10.

Assume an operation code of 71. During D9 time B-A gates will be present on the B0 and Q1 input lines. This can only result in turning on the B0 and Q1 latches of the units position. During D10 time, B5 and Q2 gates will be able to turn on the B5 and Q2 latches of the tens position.

Once on, any latch has a latch back circuit through a mix diode and will remain on until reset by a pulse applied to its pin 4.

Notice that pin 4 of all latches connects to a common line. This line is pulsed to reset the operation code register at the beginning of each restart, with a program reset signal from the control console or at D0 of a TLU band change (WD 7-20A MIX at 11K diodes 3, 5, 6).

#### Dynamic Selection Circuits

The quinary portion of the tens position of an address and both portions of the units position, indicate the word position within a band. It is the function of the dynamic selection circuits to switch the outputs from the Q tens and B and Q units latches of

the address register with timing pulses to produce a D9 gate one word early, the presence of which indicates that the word position specified by the address is about to pass under the heads. This gate will be used to time the opening of the general storage read-in switching (RIGS gate) on all operations requiring read-in to general storage from the distributor (20 Codes) and to time the opening of distributor or program register read-in switching on operations where they receive a word of information from general storage. This includes all I half cycles where the i-address is a general storage location, and D half cycles on 10's and 60's codes where the operand or operator must be transferred from a general storage location to the distributor.

The dynamic selection gate is developed *one word early* to insure that at least one full word interval will elapse before the general storage read-write circuits are used after they are energized by the address register outputs. That is, the timing gates with which the address register outputs are switched are chosen so that the dynamic selection gate will occur for the word interval preceding the one during which the read-in gate will actually be open. For this reason the dynamic selection circuits produce a gate which is called *one-word early dynamic selection*.

This *one-word early* D9 gate is then switched with timing pulses, in the control commutator, to turn on latches whose outputs are the exactly timed general storage, distributor or program register read-in gates.

The chart of Figure III-4 shows the specific combination of Q Tens, B Units and Q Units values, which define each word position on the drum and when each of these combinations must produce a dynamic selection gate. Notice that each combination appears in the word interval preceding the one which it represents. The switch and mix circuitry used to match these combinations with the necessary sector and word timing gates to produce the *one-word early D9 dynamic selection* gate, is shown in Figure III-4. These same circuits, in detail, are shown in WD 7-00 CU.



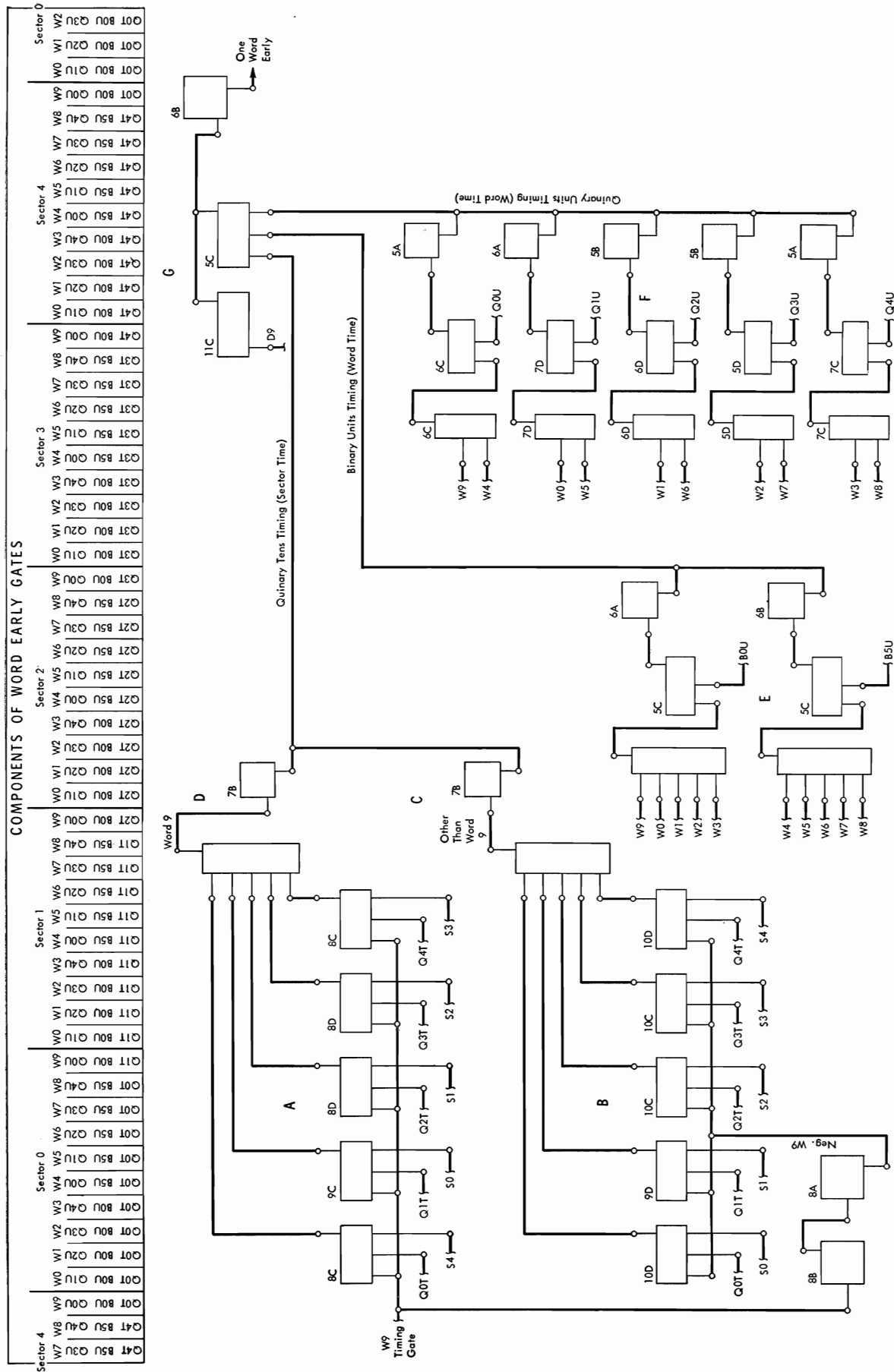

Figure III-4. One-Word Early Dynamic Selection

An example of the operation of the dynamic selection circuits follows:

Assume that the address 0038 is in the address register. A one-word early D9 gate at word time 37 should be developed.

1. Q3 tens output of the address register is switched with S2 and a W9 gate at A.
2. Q3 tens output of the address register is switched with S3 and a negative W9 gate at B.
3. These two switches operate cathode followers at C and D to provide an S2 W9 gate and an S3 W0 through W8 gate. This gives one input to the switch at G.
4. B5 units output of the address register is switched with W4 through W8 at E to provide another input to the switch at G.
5. Q3 units is switched with W2 and W7 at F to provide the third input to the switch at G.
6. The fourth input to the switch at G is a D9. These inputs coincide only at D9, W7, of S3 to give a one word early D9 gate at word time 37.

### CONTROL CONSOLE KEYS

THE functions of most of the switches, keys, and lights on the control console are such that they may be logically grouped with program controls. These are shown in WD 7-01, 7-02, 5-10 and 5-11.

#### Error-Sense Reset Key

The error-sense, error-stop and error-reset circuits, shown in WD 7-30, will be discussed in a later section. The error-sense reset key (WD 7-02) resets the error-sense latch. When this key is depressed, control console terminal C35-1, normally at -50 volts, is raised to ground. This raises terminal 9-Gy (WD 7-30) to ground and resets the error-sense latch.

#### Error-Reset Key (WD 7-02A)

When this key is depressed, terminal C42-3 is raised to ground. This raises terminal 9Bz (WD 7-30) to ground, turns off the error-stop latch. Also terminal 9Cx (WD 7-30) is raised, through diode 12 at 7C, thus resetting any error-detection circuits on chassis 2, 7, and 8, which may be on. The diode at 7C acts as a filter. It allows both the error-reset key and the signal from the error-reset cathode follower at 4-H

pins 6, 8 to operate the reset line to chassis 2, 7, and 8 but only allows the error-reset key to turn off the error-stop latch.

#### Accumulator Reset Key WD 7-02B

When this key is depressed, one of its sections parallels the error-reset key and energizes the error-reset circuits as just described. The other section raises terminal C42-2 to ground. C42-2 connects the following commoned chassis terminals:

9Nc (WD 7-21AL), to reset overflow sense latch  
 1Jx (WD 6-00EU), to reset accumulator to zeros  
 3Wd (WD 8-30DL), to turn on the manual accumulator reset latch and reset all necessary arithmetic control latches

4Uz (WD 6-10BU), to reset distributor to zeros  
 1Fl (WD 8-31AU), to reset TLU control latch

The action of the accumulator reset key is paralleled by an accumulator reset signal from the cathode follower at 9-7H (WD 7-30) on an error-sense operation. When this signal is developed it feeds 4K pin 5 on WD 7-21AL and then 9Nc on WD 7-21AL and thus all of the aforementioned commoned chassis terminals.

#### Program Reset Key (WD 7-02B)

When this key is depressed, one of its sections parallels the error-reset key and energizes the error-reset circuits. The other section raises terminal C42-4 on WD 7-01C to ground.

C42-4 connects to one segment of the control switch. If this switch is in the RUN or ADDRESS STOP position, a *set 8000* signal is sent to the address register; if it is on the MANUAL position, a *reset 8000* signal is sent to the address register.

C42-4 also connects to several commoned chassis terminals as follows:

9-11G1 (WD 7-10AU) to turn on the program reset latch and reset all necessary program control latches.

8Xb (WD 7-00CL) to turn on the *reset except 8000* latch.

1Xy (WD 6-20BU) to reset the program register to zeros.

9Hz (WD 7-20A) to reset operation register

9-8P4 (WD 7-21BL) to reset codes 70 and 71 latches.

The action of the program reset key is paralleled by a program reset signal from the error-sense circuit. This signal comes from the cathode followers at 9-8H (WD 7-30) on an error-sense operation. Pins 5 and 8 of 8H connect to 9-11K4 (WD 7-20A) and thence back along the program reset latch output lines to the commoned chassis terminals.

### Transfer Key

The function of this key is explained under *address transfer*.

### Program Start Key WD 7-01C

This key provides a way to manually turn on the run latch and allow the control commutator to advance. It has two sections. In its normal position the #2 section brings + 150 volts potential to C35-3 (WD 7-01) through the auxiliary program start switch to 9Fz (WD 7-10AL). Cathode follower 6P conducts and holds the manual start-stop latch off and pin 5 of 8E down. When the program start key is depressed, this circuit is opened. The manual start-stop latch remains off but is now free to be turned on by an input signal. Section 1 of the program start key or auxiliary program start key supplies plate voltage to the cathode follower at 9-9F, which supplies a signal to turn the manual start-stop latch on with the arrival of the next WPU. When the start-stop latch goes on, the voltage at pin 8 rises and impulses the capacitor-coupled cathode follower at 7F. This output turns on the run latch and starts the control commutator. In this way it is insured that the run latch will always turn on at the beginning of an upper word interval.

### Program Stop Key (WD 7-01C)

This key turns the run latch off so that the control commutator will stop at the end of the next restart word interval. This allows the operation in process to be completed but does not allow the next one to start.

When this key is depressed, C49-1 and 9Ey (WD 7-10AU) are raised to + 150 volts. This supplies plate voltage to the 3, 5 side of cathode follower 9F turning on the stop latch. The output of the stop latch is switched with the next restart A to turn off the run latch.

### Computer Reset Key WD 7-02B

When dc power comes on, the normally closed computer reset key and auxiliary computer reset key apply + 150 volts, from terminal C36-6 (WD 7-01C) to R1 and R2. These relays are energized continuously except when one of the computer reset keys is depressed. When the key is used, R1 and R2 drop. R1-1 parallels the error reset key and energizes the error-reset circuits. R1-2 parallels the accumulator reset key and energizes the accumulator reset circuits as above. R1-3 parallels the program reset key and energizes the program reset circuits, as above. Thus, computer reset is equivalent to both accumulator and program reset.

#### Write Inhibit Circuit

While computer reset is in process, R2 points on WD 7-02A are open. This removes -250 volts from the voltage divider and causes 6-7W pin 4 to remain positive even though a NBP is applied to pin 5 of 7W (WD 1-00AL). Thus, no WSP can be developed while computer reset is in progress, and no writing can be done.

## CONTROL CONSOLE LIGHTS

### Checking Lights (WD Section 7-02)

The checking lights are provided to give an indication as to where an error has occurred when one is detected by any of the checking circuits. One side of all the lights are commoned to terminal C41-7 (WD 7-01C) which is the tap on a voltage divider between -250 and -70 volts. The resistor ratio is such that C41-7 is at about -80 volts. The other side of each light connects to an error-detection latch. When the latch is off, its output level is about -35 volts. This 45-volt drop across the neon bulb is not sufficient to fire it. When the latch turns on, its output level rises to about + 10 volts, and the 90 volts across the bulb causes it to fire.

#### Clocking Light

This light indicates an error in one of the ring circuits or an error in special pulse timing. The sector-ring error-detection circuit-output is available at 7Qz (WD 1-30B). The digit and word rings are on chassis

13 in the 655. Their error-detection outputs are sent via connector cable to C59-4 on the back of the 650 and thence by cable to C42-5 on WD 7-02A. Terminal 7Qz also connects to C42-5. The special pulse timings are checked for errors on WD 1-20BL. Thus, the clocking light comes on if error is detected in any of the ring circuits or special pulse circuits.

Terminal 7Qz also connects to 9Cz (WD 7-30) to turn on the error-stop latch.

#### Accumulator Light

This light indicates that a non-valid bi-quinary digit representation has been detected by the accumulator validity check circuits (WD 6-30A). Any extra or missing bi-quinary bits, as indicated by the status of the accumulator *on-time* latches will be detected by the switch-mix validity-check circuitry and will turn on the accumulator error latch. The output of this latch raises terminal 2Fb which connects to C42-6 (WD 7-02A) and lights the accumulator error light.

Two other checking circuits also cause an error-stop operation but without turning on the accumulator error latch and light. These are the TLU carry or no-carry check and the accumulator zero or non-zero check, as shown on WD 6-31.

The output of the accumulator error latch is also one of the five conditions that can provide an error-stop signal at 2 Hd (WD 6-30C), to 9Cy (WD 7-30) to turn on the error-stop latch.

#### Error-Sense Light

Terminal C42-7 on WD 7-02A connects to 9Gz (WD 7-30). When this terminal is raised by turning on the error-sense latch, the error-sense light goes on. The circuits to turn on the error-sense latch will be described later.

#### Program Register Light

The program register on-time latch outputs are checked by validity-checking switch-mix circuitry on WD 6-30B. Any non-valid digit value will turn on the program register error latch. The output of this latch raises terminal 8Mx which connects to C42-8 (WD 7-02) and turns on the program register light.

The program register error latch output is also one of the five conditions that develop an error stop signal at 2Hd, to 9Cy (WD 7-30) to turn on the error stop latch.

#### Storage Selection Light

This light is turned on when terminal 8Fw is raised, whenever the storage check double latch is turned on (WD 7-00AU). This latch is turned on whenever an invalid address appears in the address register or in the event of a failure to write on any general storage read-in operation or a double write situation. The no-write, multiple-write detection circuit is shown as part of the read-write circuitry in WD 4-10EU. These no-write, multiple-write signals are brought to chassis 8 via 8Fy and 8Fz (WD 7-00). No-write is switched with a RIGS gate or BS to GS gate and mixed with multiple-write to provide a no-write, multiple-write signal to turn on the storage check latch. The storage check latch will also be turned on by a buffer validity check latch output (WD 6-33B).

#### Distributor Light

The distributor on-time latch outputs are checked by validity checking switch-mix circuitry on WD 6-30C. Any non-valid digit value will turn on the distributor error latch. The output of this latch raises terminal 2Fc, which connects to C44-2 (WD 7-02) and turns on the distributor light.

The distributor error latch output is also one of the five conditions that develop an error-stop signal at 2Hd, to 9Cy (WD 7-30) to turn on the error-stop latch.

#### Overflow Light

The overflow light indicates when an accumulator overflow condition has occurred. The overflow condition may be used to stop the machine, or it may be stored for later interrogation by a code 47.

Accumulator overflow conditions are as follows:

1. Add or Subtract—when factors added or subtracted exceed the capacity of the accumulator (test for carry at D10U [Figure III-5]).
2. Shift and Count—if the maximum allowable shifts have been taken and the accumulator still has a zero in D10U position (test for D0L carry except on first shift cycle).
3. Divide—developing a quotient digit greater than nine in any one left shift position (test for a carry D1L when quotient digit latch is on).

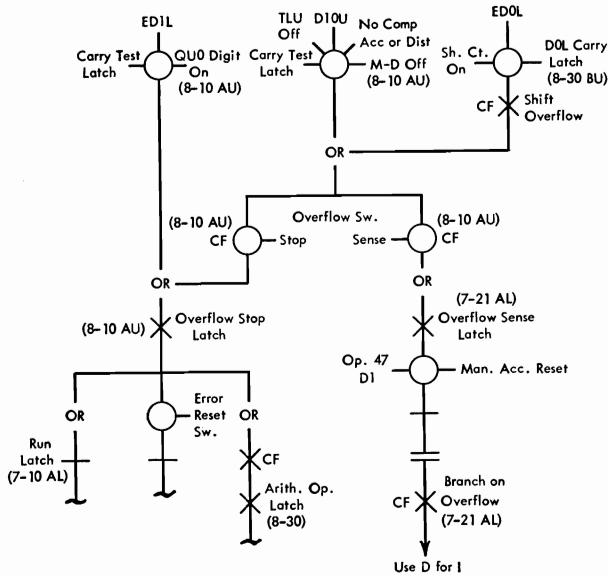

Figure III-5. Overflow Sense-Stop

Figure III-5 shows the overflow circuit operation. Sensing an overflow will turn on the overflow stop latch if the overflow switch is set to STOP or the overflow sense latch if the switch is set to SENSE. Turning on the overflow stop latch turns the run latch off and holds the arithmetic operation latch on. With the arithmetic operation latch held on, no end-of-operation signal will be developed to turn off the operation interlock latch. Thus, the control commutator is interlocked and cannot advance until the overflow stop latch has been turned off. Depressing the error reset key turns off the overflow stop latch.

When set to SENSE, an overflow condition turns on the overflow sense latch and the machine continues to run. The latch will remain on until reset by a code 47 or manual accumulator reset. NOTE: Divide overflow will stop the machine regardless of the overflow switch setting.

**Operating Lights (WD 7-02B)**

The operating lights are provided to give an indication of what units in the calculator are in operation.

**Input-Output**

The input-output light comes on at the beginning of a control commutator D half cycle on a 70 code operation (code 70, 71, or 72). It remains on until a restart signal is provided by a cam that closes as the

input-output unit starts its cycle. These circuits are shown in WD 7-21BL. When the read-punch D control signal of the control commutator coincides with a 71 output from the operation code register, terminal 9Mz is raised. This raises C44-4 (WD 7-02B) and turns on the input-output light.

These punch code circuits will be explained later.

**Program Light**

The program light indicates that the calculator has stopped because of a condition that has turned off the run latch. When the run latch is OFF, its OFF output is available from 4E5 (WD 7-10AL). The OFF output is used to turn on the program light (WD 7-02B).

**Accumulator Light**

The accumulator light will be on all during arithmetic and shift operations. These are the operations in which the accumulator is used. The operation interlock latch, WD 7-10CL in the control commutator, will be on at these times. Its output raises terminal 9Yc (WD 7-10CL), which connects to C44-6 (WD 7-02B) to turn on the accumulator light.

**Data and Instruction Address Lights**

These lights indicate whether the control commutator is in an I or D half cycle, and thus whether the address in the register is a data or instruction address. The alternation control latches in the control commutator are connected to form a flip-flop device, which alternates on each restart or Use-D-for-I signal. The I latch output, pin 5 of 9-11F (WD 7-10AU), connects to terminal 9Gx; to C44-8 (WD 7-02) to turn the I light on. The D latch output, pin 8 of 11F, connects to terminal 9Hw; to C44-7, to turn the D light on.

**Operation and Address Register Lights (WD 7-01)**

These lights indicate the bi-quinary value of the number in the operation code and address register.

One side of all lights is commoned to the -80 volt tap of the voltage divider (C41-7, WD 7-02). The other side of each light connects to its corresponding address or operation register output latch, via the C terminals shown on WD 7-01. Thus the lights are a direct indication as to which latches are on.

### Display Lights (WD 5-10)

There are ten display light positions, one for each of the digit positions of the capacitor storage unit to be displayed. There is also a sign position having two bulbs, plus and minus, for use when the distributor or accumulator is being displayed. The neon lights respond to coincidence of an information gate and a digit timing gate. This coincidence will occur once every word interval for distributor and program register and once every two word intervals for the accumulator. When the control commutator is stopped so that the information in the capacitor storage units is not changing, the same information will be supplied periodically to the same bulbs. The bulbs so pulsed will appear to glow continuously.

The potential of one terminal of one bulb in each position is determined by the center tap of a voltage divider consisting of two 100K resistors. One end of this divider receives an inverted information gate; the other end receives an inverted timing pulse. Thus a bulb receives all information gates from its bi-quinary input lines but responds only to those that occur during its digit timing interval. For example, the B5 bulb of D1 receives all B5 gates but responds

only to those that occur at D1 time. The other bulb terminal is commoned to a similar terminal of the corresponding bi-quinary bulbs of each of the other digit positions.

Normally, the plates of the PW504 timing gate inverters and the PW504 information gate inverters are at +250 volts and, therefore, the center taps of the bulb dividers are at +250 volts. The other side of the bulb is at 206 volts. This 44-volt difference across the bulb is not sufficient to fire it. Figure III-6 illustrates this circuit.

The plate of the PW504 timing gate inverter drops to +50 volts when the timing gate causes it to conduct, pulling one end of the bulb divider down to +50 volts. If no inverted information gate is present, the other end of the divider remains at +250 volts. In this case, the center tap drops to +150 volts. The difference across the bulb is 56 volts, still not sufficient to fire the bulb. If an inverted information gate coincides with the inverted timing gate, both ends of the divider, and the center tap, drop to +50 volts. This difference of 156 volts is more than sufficient to fire the bulb.

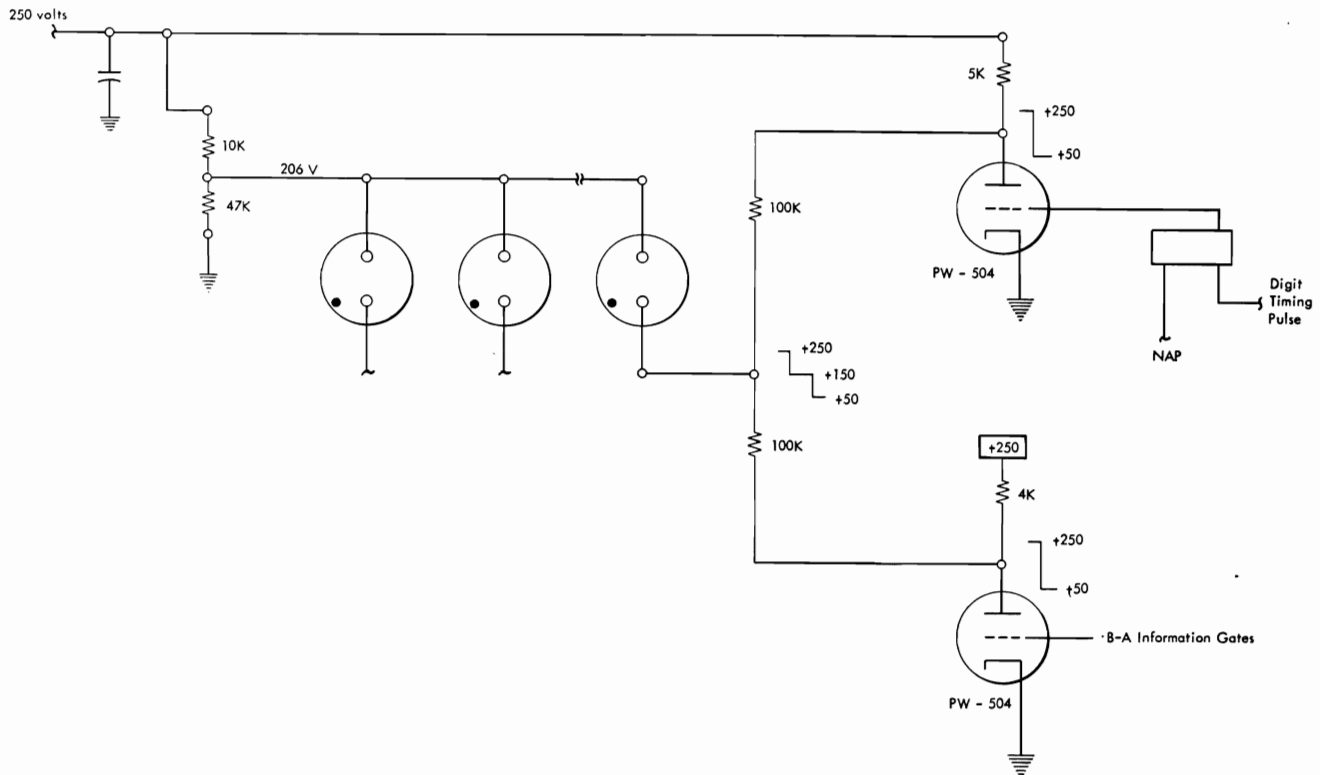

Figure III-6. Display Light Schematic

There are two lights in the sign position (D0). The plus light fires when a Q4 information gate coincides with a D0 timing gate. The minus light fires when a Q3 information gate coincides with a D0 timing gate. This follows from the fact that a plus sign is stored in the distributor as a 9, while a minus is stored as an 8. The Q4 and Q3 information gates will be available at D0 time only from the distributor or the accumulator sign latches, because there is no D0 position in the program register.

## CONTROL CONSOLE SWITCHES

### Address Selection Switches WD 7-01

The address selection switches have two functions:

1. To set up a four-digit address that it is desired to manually transfer to the address register.
2. To set up a four-digit address that is to be compared with the contents of the address register to develop an address stop signal when the two addresses are the same, if the control switch is in the address stop position.

#### Address Transfer

The outputs of the 28 address register latches (WD 7-00) connect to the binary and quinary sections of each address selection switch (WD 7-01). When a decimal value is set in a switch, the wiring is such that a circuit is completed between the binary and quinary common switch segments and those address register latches that represent the decimal value.

To transfer a number from the switches to the address register latches, the address is set in the switches. The control switch is set to **MANUAL**, and the transfer key is depressed. The following circuit is used to turn the proper latches on:

The address selection switches connect the diode cathodes, in units 15A, 15B, and 16A (WD 7-01C) to the selected address register latch outputs. Normally the address register will have been previously reset by depressing the program reset key. Assuming no voltage drop in the diodes, the diode plates will be at the same potential as the address register latch outputs (about -35 volts). Depressing the transfer key raises the diode plates essentially to ground potential; via the control switch set to **MANUAL**. Conduc-

tion of the diodes raises the connected latch output lines, through the address selection switches, to ground potential. Reference to WD 7-00 will show that when any latch output line is raised to ground, the latch will be turned on through its latch-back diode.

#### Address Stop

With a specific address set in the address selection switches, all eight lines from the common segments will be raised only when the corresponding address register latches are on. When this occurs, all eight inputs to the switch at 15A, 15B, and 16A (WD 7-01C) are raised. If the control switch is in the **ADDRESS STOP** position, this signal is sent through a double inverter and capacitor-coupled cathode follower. The resulting spike turns off the run latch.

### Control Switch WD 7-01C

The functions of this switch have been covered in connection with the address register and the address selection switches.

In **ADDRESS STOP** it allows an address stop signal to be developed when the address selection switch setting is matched by the address register latches and causes any reset of the address register to be to 8000 rather than blanks.

In **RUN** it also causes any address register reset to be to 8000.

In **MANUAL** it allows the transfer key to transfer a number from the address selection switches to the address register and causes any reset of the address register to be to blanks rather than 8000.

With the control switch set to **MANUAL**, the **RUN** signal for the control commutator, and the run control cathode follower output are driven negative.

### Master Power Off Switch (WD 7-02A)

This is a recessed toggle switch whose operation immediately cuts off all power to the machine. It is provided for use *only* as a safety measure and should not be used for normal machine operation, because it disregards the normal power on and power off operating sequences.

### Half-Cycle Switch (WD 7-01C)

The action of this switch parallels that of the program stop key. Thus when it is in the half cycle position, the control commutator is stopped at the end of each restart word interval. Each depression of the program start key will allow it to advance until the next restart. Thus the machine may be manually half-cycled through program steps.

### Programmed Stop Switch (WD 7-01C)

When this switch is in the STOP position and an 01 operation code is sensed, the run latch is turned off, stopping the control commutator. This action was described under *Program Light*.

### Error Stop-Sense Switch (WD 7-01C and Figure III-7)

This switch is provided to allow the use of self-correcting program routines. The machine can be made to respond to a detected error in either of two ways, depending upon the setting of this switch.

1. **ERROR STOP.** With the switch in this position, an error will cause the run latch to be turned off and the control commutator to be stopped at the end of the operation on which the error was detected.

2. **ERROR SENSE.** With the switch in this position, an error will turn the run latch off momentarily. Automatic program reset, accumulator, and error-reset signals will be developed, which will reset all units just as if the program, accumulator, and error-reset keys had been used. The address register will be reset to 8000 (because the control switch is in the RUN or ADDRESS STOP position) and the run latch will be automatically turned back ON. The next instruction will be taken from the switches (8000) instead of the intended I-address, and the machine can branch into a self-correcting routine, if such a routine is provided in the programming.

#### Error Sense

With the switch in this position, and after the error stop latch turns on, the circuits act as follows:

1. The error-sense latch is turned on and lights the error-sense light. This latch is reset only by a subsequent depression of the error-sense reset key.

2. Program accumulator, and error-reset signals are

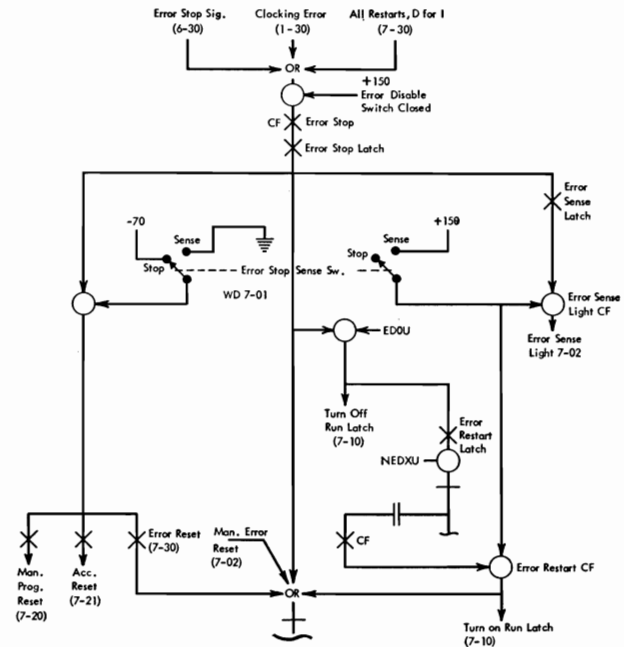

Figure III-7. Error Stop and Sense Function Chart

developed as a result of the signal coincidence at the switch at 8G diodes 11, 12. These signals parallel the similar signals developed when the accumulator, program, and error-reset keys are used except that the error-reset signal from 4H pin 8 does not reset the error-stop latch because of the blocking effect of diode 12 at 7C.

3. The run latch is turned off with the next ED0U gate by the switch at 7D diodes 1, 2, and the error-restart latch is turned on by the switch at 3D diodes 6, 7. The error-restart latch remains on through its coincident latch back circuit until the next NEDXU.

The error restart latch is turned off with the next NEDXU. The resulting positive pulse from 3F pin 5 causes a spike output from the capacitor-coupled cathode follower, which is applied to the grid of the cathode follower at 7E. With the error stop-sense switch in the SENSE position, the cathode follower at 7E produces a positive spike to turn the run latch back on, and the error-stop latch off. The error-sense light remains on until the error-sense reset key is depressed.

#### Error Stop (Figure III-7)

With the switch in this position, the output of the error stop latch is able *only* to turn the run latch off. The diode switch at 8G diodes 11, 12 is blocked as are the cathode followers at 7J and 7E pin 6, 7, 8.



### Error Disable Switch (WD 7-30)

The error disable switch is a control console cover interlock switch that may be opened when the control console panel is swung out. It provides anode voltage for the cathode follower at 7E pin 10 and allows the output of the error stop latch to be used. Any detected error (except those that operate the storage check latch, WD 7-00AU) will cause the error stop latch to turn on.

### Overflow Stop-Sense Switch

The functions of this switch were described under *Overflow Light*.

### Display Switch (WD 5-11B)

The main function of the display switch is to select the accumulator (upper or lower), the distributor or the program register for display by the display lights. It also allows the control commutator to cycle continuously if it is in the upper accumulator, lower accumulator, distributor, or program register positions, but allows it only to cycle once in either of its manual operation positions (read-out storage or read-in storage). This switch also removes plate voltage from the general storage read-out latches in its read-in storage position to prevent a conflict of information on the selected storage line on a read-in storage operation.

The switch is a six-position switch with three sections. The third section supplies anode voltage to the upper accumulator, lower accumulator, distributor, or program register light selection cathode followers, depending upon its setting. Outputs from the accumulator on-time latches are switched with upper and lower word gates to provide inputs to the upper and lower light selection cathode followers. On-time outputs from the distributor and program register drive the distributor and program register light selection cathode followers. All these cathode follower outputs are commoned and feed the bi-quinary, light selection output lines. The information on these lines then consists of on-time B-A information gates from the selected capacitor storage unit. These lines connect to terminals 2Ca, 2Bd, etc., on WD 5-11B. These terminals connect to C10-3, C10-2, etc., on WD 5-10C and are the information input to the display lights.

Notice that anode voltage is supplied to the distributor light selection cathode followers by either the distributor, read-out storage, or read-in storage positions of the switch. On a read-out storage operation, the contents of a storage location, specified by the number in the address register are transferred to the distributor and displayed from there. On a read-in storage operation the information set in the storage entry switches is transferred to the distributor and then to general storage.

In order for the control commutator to advance normally, a *run* signal must be available when the run latch is on, provided the display switch is in any position other than the two manual operation positions (read-out storage and read-in storage are both manual operations). WD 7-10AL shows that the ON output of the run latch raises the grids of three cathode followers, run control, manual read-out storage, and manual read-in storage. When the second section of the display switch is in the read-out storage position (WD 5-11B), + 150 volts is applied to C43-5, to 9Dz and the manual read-out storage. Cathode follower at 9E; therefore, when the run latch is on, it provides the manual read-out storage signal instead of the run signal. In the read-in storage position, + 150 volts is applied to C43-4, to 9Dw, and the manual read-in storage cathode follower at 9E. In this case, the run latch, when on, provides a read-in storage signal instead of the run signal.

On the read-in storage operation an 8000 control signal is developed by the manual read-in storage signal. This opens the path between the storage entry switches and the selected storage output line, allowing the storage entry switch information to enter the distributor. (The manual read-in storage signal also provides a R.I. distributor gate.) Meanwhile, the address register output has energized the general storage read-write matrix. Therefore, when a RIGS gate is provided, timed by the *one-word early* selection circuits, the switch information (now in the distributor) is read into the selected general storage location.

Reference to the general storage read-write matrix circuits (WD 4-10) will show that information is available from the selected band as long as a valid general storage address is in the address register. Normally this information operates the five general storage

read-out latches, supplying a stream of B-A information gates to the selected storage output line. If this is allowed to happen, there will be a conflict of information from entry switches and the general storage band on the selected storage line. To prevent this, the general storage information is blocked on a read-in storage operation.

When the first section of the display switch is in the READ-IN STORAGE position (WD 5-11B), -50 volts is applied from the control switch set to MANUAL to the switch at 4H (WD 4-00B). Therefore, the cathode follower outputs will be down, blocking the general storage latch output from reaching the selected storage output lines.

### Storage Entry Switches (WD 5-10)

These switches provide a way to insert manually a word of information into any storage location. They are addressable (8000) and therefore may be used as a source of information by the program routine. As such they are used as the alternate source of an instruction word on self-correcting error program routines.

There are eleven switches, one for each significant digit of a word and one for the sign.

Each switch has two sections, one for the binary level and one for the quinary level. Digit timing gates corresponding to the digit position represented are fed to the common segments of each switch. For a given decimal setting of a switch, digit gates will be distributed to the two bi-quinary lines that represent the digit. In the case of the sign position, a plus setting distributes a D0 gate to the B5 and Q4 lines, while a minus setting distributes a D0 gate to the B5 and Q3 lines.

These storage entry switch outputs are used either on a manual read-in storage operation or when the output of the address register is 8000. In the first case, a forced 8000 signal (*beat 8000*) is developed at terminal 9Wz (WD 7-10CU) by the manual start read-in distributor latch and is applied to C20-2 (WD 5-10C). In the second case, an 8000 address signal is developed at terminal 8Ea (WD 7-00BU) from the address register output and is applied to C19-2 (WD 5-10C). These signals are mixed at 16B so that either signal conditions the diode switches at 14B, 15A, 15B, and 16A. The storage entry switch outputs are thus gated through to the selected storage output lines by either an 8000 address or a *beat 8000* signal from where they may enter the distributor or program register as the case may be.



## SECTION IV. ARITHMETIC UNITS

### CAPACITOR STORAGE UNITS

THE PRINCIPLE of the basic capacitor storage binary cell was discussed in Basic Principles (Section 2) under Capacitor Storage. In the 650, three major storage units are built up from these basic cells: the distributor, the program register, or program step storage unit, and the accumulator storage unit. Each of these units is much the same in principle, although slight differences exist in methods of read-in and regeneration control.

#### Distributor

Wiring diagram 6-10 show the circuits comprising the distributor and its regeneration, read-in and reset controls. The unit consists of a capacitor storage matrix, even- and odd-digit amplifiers and blocking inverters, early latches, on-time latches, and pedestal cathode followers together with entry switching and read-in and regeneration controls.

The matrix is made of eleven columns of seven capacitor storage cells. There is one column for each digit storage position and one for the sign. There are seven cells in each column, one for each of the seven bi-quinary bits. The distributor is required to store eleven digits, D0 being the sign storage position.

The seven cells of each column have their read-out terminals common and driven by a one-digit-early gate and their read-in terminals common and driven by an on-time digit gate.

The capacitor terminal of each of the even-digit cells in a bi-quinary row connects to a common pedestal line controlled by a pedestal cathode follower. The same is true of the odd-digit cells.

For purposes of explanation assume that the distributor has been reset and is storing plus zeros. In this case, the D0 position contains a 9 (only the B5 and Q4 capacitors are discharged). All other digit positions contains zeros only (B0 and Q0 capacitors discharged).

#### Distributor Regeneration

At DX time a B-A read-out gate is applied to the D0 position. The B5 and Q4 capacitors charge, developing capacitor charge *spikes* across the resistor in the corresponding pedestal cathode followers. These *spikes* drive their corresponding even-digit amplifiers, which are free to operate because their blocking inverters normally conduct only during even-digit time intervals (DX is an odd-time interval). These amplifier outputs turn on the corresponding B5 and Q4 early latches. These latches stay on for the remainder of the DX interval and are reset by an inverted AP through the associated reset inverters. The early latches while on, furnish a distributor early output.

When the early latches go off at A time, the corresponding on-time latches are pulled on by a pulse from the left anode of the early latches through a capacitor-coupled inverter. These on-time latches are held on until the next A time through a latch back circuit controlled by a NAP, and while on, furnish an on-time output during D0 time. The on-time latch outputs also switch with NAPs and (in this case) an even-digit gate to raise the B5 and Q4, even-digit pedestal lines during D0 time. This raising of the pedestal lines coincides with the D0 read-in gate on the D0 position and allows the B5 and Q4 capacitors to discharge on top of the pedestal as explained in Basic Electronic Circuits. The even-digit amplifier blocking inverters are conducting during D0 time while the even-digit lines are being pedestalled, thus preventing the amplifiers from responding to the pedestal pulse and incorrectly turning on the early latches.

At the same time the D1 position (an odd position) is being read-out through the odd-digit amplifiers and the foregoing process is repeated with read-out occurring at D0 and read-in at D1 time. The B0 and Q0 latches will be active, because the B0 and Q0 capacitors were discharged.

Note the vacuum diodes connected between read-in and read-out lines of the capacitor storage cells. They clamp the pulsed output of the read-in inverters to that of the read-out cathode followers (about + 10 volts) to stabilize the capacitor output spikes.

This processing reading out one digit early, reading in on-time and pedestalling two of the seven lines during read-in time from the on-time latches is repeated for each digit position. Each column of capacitors is tested once each word interval and thus is required to maintain its state of charge or discharge for 96 microseconds.

In this way a number stored in the unit is continuously available from the early and on-time outputs and is continually regenerated.

Reading a new number into the unit merely requires the circulating regeneration path to be opened and that two of the seven pedestal lines be operated each digit time by on-time pulses from the source of the information instead of pulses from the distributors on-time output.

This is accomplished by the distributor read-in and regeneration controls. In the case of the distributor, regeneration is interrupted by causing the output of the regeneration control latch to energize all of the even- and odd-digit amplifier blocking inverters so that the outputs from the capacitor matrix cannot turn on the early latches. With the early latches blocked, the on-time latches cannot be turned on and regeneration is prevented. Instead, an output from either of the distributor read-in control latches (storage to distributor read-in or accumulator to distributor read-in) will open read-in switching, allowing the on-time latches to be turned on by on-time output pulses from either selected storage or the accumulator. When regeneration is interrupted by blocking the turning on of the early latches, it must be done by a gate that is one digit early with respect to the gate that opens the read-in switching.

WD 0-99 shows that the distributor can be read into from two sources:

1. Selected storage that includes any general storage location, the storage entry switches (8000), and upper or lower accumulator when selected by an 8002 or 8003 address.
2. Directly from the accumulator on-time output (Codes 20, 21, 22, 23).

The selected storage source is used to enter information into the distributor on all arithmetic operations (10's and 60's codes). The first step of any arithmetic operation is the entering of data into the distributor from a storage location specified by the D-address of the instruction word. The data is then available from the distributor outputs for use in accomplishing the operation.

On 10's and 60's operations, a signal is sent from the program control commutator to operate the distributor read-in and regeneration controls. This signal occurs at DX time of the word when the storage location containing the data to be entered is in position to be read out.

To enter a selected word of information into the distributor, the distributor's selected storage entry switching must be open for D0 through D10 of the selected word interval and its regeneration path must be blocked from D0 through D9 time. WD 6-10CU shows how the read-in distributor signal (DX) turns on the read-in distributor from storage latch and in turn the distributor regeneration control latch to provide the necessary read-in and regeneration blocking gates.

The read-in gate is actually open during DX although not needed until D0 time. No harm is done, however, because no output is available from any general storage location or the switches at DX time, and any DX output from the accumulator is a zero. A zero at DX time would only turn on the B0 and Q0 on-time distributor latches, which are forced on at DX anyway by a distributor reset circuit, to provide an on-time distributor output at DX to satisfy the distributor validity check circuits.

Regeneration is not blocked at the beginning of DX time when the distributor's sign position is being read out because of delays between the development of the read-in distributor signal and the blocking inverters. Instead the Q3 and Q4 early-latches are held OFF every DX of a read-in distributor operation. The B5 early-latch is not held off; since in going off it turns on the B5 on-time latch at D0 time. This causes no failure because the B5 on-time latch is turned on at D0 time anyway from selected storage.

The read-in distributor from storage latch and the regeneration control latch are turned off with a D10 DP. Actually they taper off, because time is required

for a latch transfer, and cannot be considered fully down until the end of D10 time. Thus the read-in gate is *up* through D10 as required. The regeneration blocking gate is held through D10 also although this would not be necessary, because no distributor position is read out at D10 time.

Whenever a manual accumulator reset gate is developed by depressing either the accumulator reset key or the computer reset key on the control console, the distributor is reset to plus zeros. This is done by holding the Q1, Q2, Q3 on-time latches off for all digits during manual accumulator reset; the B5, Q4 latches on and the B0, Q0 latches off for D0 during manual accumulator reset; the B0, Q0 latches on and the B5, Q4 latches off for all digits except D0 during manual accumulator reset. WD 6-10BU shows the switching of manual accumulator reset with D0 and ND0 to accomplish this resetting.

### Accumulator

The accumulator is a capacitor storage unit similar in principle and circuitry to the distributor and the program register except that it has capacity for two words of storage. The lower accumulator has twelve storage positions, DXL, D0L and D1L through D10L positions. The upper accumulator has 10 positions, D1U through D10U. There is a two-digit time gap between the D10L and D1U positions, because there are no DXU or D0U storage positions.

The accumulator (WD 6-00) consists of a 22-digit capacitor storage matrix, even- and odd-digit amplifiers and blocking inverters, early latches, on-time latches, read-in and regeneration switching, pedestal cathode followers and reset controls. Stored information is continuously regenerated as long as the accumulator regeneration gate is up. As with the distributor and program register, regeneration is accomplished by allowing the on-time latch outputs to control the pedestal cathode followers.

All read-in to the accumulator is to the pedestal cathode followers. During the read-in operation the following controls are operated: Accumulator regeneration is turned off, opening the circuit between on-time latches and pedestal cathode followers. Accumulator read-in is brought up, completing the circuit between adder output and pedestal cathode followers. The adder output now replaces the on-time

latch output and read-in from the adder takes place.

It is also possible to control the pedestal cathode followers from the accumulator early latch outputs. This is done when the accumulator regeneration gate is turned off and the right-shift gate is developed. This is used to accomplish a right-shift operation.

The accumulator regeneration, accumulator read-in, and right-shift latches that develop the read-in and regeneration control gates are part of the arithmetic control circuits and thus are not shown with the accumulator.

The accumulator is read into during the execution of the following codes: 10, 11, 14, 15, 16, 17, 18, 60, 61, 64, 65, 66, 67, 68 (add, subtract, multiply and divide operations), 30, 31, 35, 36 (shift operations), 84 (TLU). Arithmetic controls for each of these operations will therefore operate the accumulator regeneration latch and accumulator read-in latch. Codes 30 and 31 will also use the right-shift latch.

The operation of these control latches will be discussed later in connection with the description of the specific operation.

Several special circuits, not found in the other capacitor storage units are associated with the accumulator to handle conditions arising because of its design and use. These circuits will be discussed in the following paragraphs.

Because there are no DXU and D0U accumulator positions, the D1U position is read out at D10L time (one accumulator digit position early). D1U cannot be read-in until D1U time. The early latches, therefore, must not be reset during DXU and D0U time. To accomplish this the A pulses, which control the early latch reset inverters, are switched with a negative D10cL-D0cU gate. (Negative digit 10 c lower to digit 0 c upper). This is a gate that is up for A time of all digits except DXU and D0U. Thus A pulses are supplied to reset the early latches except at DXU and D0U times.

On all operations requiring an accumulator entry to the adder, except the left-shift codes (35 and 36), the accumulator early output is used. On these operations therefore, the D1U information contained in the early latches is presented to the adder for three successive digit time intervals, D10L, DXU, and D0U. It will be seen later, when the adder circuits are described, that the adder does not accept this informa-

tion for analysis until D0 time. Reset of the adder carry latches is prevented during DXU and D0U time so that their carry or no-carry information setup from the D10L digit is still available at D0U time for use with the D1U information to provide the correct result.

Because of the lack of DXU and D0U positions and of the previously mentioned behavior of the early latches during DXU and D0U time, there is no normal input to the on-time latches at DXU and D0U times. To satisfy the validity check circuits an on-time DXU and D0U output of zero is created by forcing the B0 and Q0 on-time latches on with DXU and D0U gates. This is accomplished through the mix circuit inputs to these two latches (WD 6-00CU).

On reset add or subtract operations it is necessary to disregard the number that may be in the accumulator and to merge, in the adder, the contents of the distributor with zeros substituted in place of the contents of the accumulator. This result is then stored back in the accumulator. The number in the distributor has been placed in the accumulator and the effect of an add or subtract with reset has been accomplished.

On manual accumulator reset operations a manual accumulator reset gate is produced by depression of either accumulator reset or computer reset keys on the control console. This forces zeros into the on-time latches for each digit during the full two accumulator word times. These on-time latch zeros are regenerated into the matrix, thus resetting the accumulator.

The D0L position of the accumulator is not used for storage of the sign. Each time a number is entered into the accumulator, its sign is determined and held in the accumulator sign latches. The output of these latches helps to determine whether the next accumulator entry to the adder will be true or complement. The output of these latches also causes either a bi-quinary 8 or 9 to be inserted into the accumulator on-time output lines at D0 time for transfer to the distributor.

The D0L position is used on multiply, divide, and shifting operations to hold the shift count number. The DXL position is used on multiply and divide to store the high order digit of the multiplicand and the high order digit of the dividend.

## ADDER

FIGURES I-11 and WD 0-99 show how the adder and its A and B entry switching fit into the machine's data flow arrangement.

The adder is used in the accomplishment of all arithmetic operations (10's and 60's except 69), the shift operations (30's) and the table-lookup operation, 84). There are two, 7-bit, bi-quinary input lines, and one 7-bit, bi-quinary output line associated with the adder. Bi-quinary digit information is presented to the adder simultaneously on each of its two inputs. The bi-quinary sum of the digits presented is available from the output.

The information entering the adder is presented digit by digit, from any of the several serial storage sources that have data flow paths connecting their outputs to an adder input. The selection of the source of information to be presented and the time of presentation to the adder are the functions of the A and B input switching circuits. These circuits are opened and closed, thus gating information to the adder, by control gates developed by the program control and arithmetic control circuits.

A delay of one digit time is incurred in the adder; i.e., the sum of two digits is available from the output one digit time after they have entered the inputs. The design of the adder is such that information must be presented simultaneously at the two inputs to obtain an output signal.

### Bi-Quinary Arithmetic

The 650 adder uses only the operation of addition to accomplish all calculations. Subtraction is achieved by entering one of the two numbers as a complement. Multiplication is done by over and over addition of the multiplicand. Division requires repeated subtraction of the divisor from the dividend. Thus the serial, one digit adder need only have the ability to receive two simultaneous, bi-quinary indications of digit values; combine them with a stored carry or no-carry indication from the preceding digit analysis, and produce a bi-quinary indication of this result. Figure IV-1 is an example of a bi-quinary addition and subtraction operation with decimal comparison.

## ADDITION

$$12345 + 67890 = 80235$$

Decimal System						Bi-Quinary System										
	D5	D4	D3	D2	D1	D5		D4		D3		D2		D1		
	B	Q	B	Q	B	Q	B	Q	B	Q	B	Q	B	Q	B	Q
Carry	1	1	1													
Adder entry A	1	2	3	4	5											
Adder entry B	6	7	8	9	0											
Adder Output	8	0	2	3	5											
						Above 5										
Carry							1		1		1					
Adder entry A	0	1	0	2	0	3	0	4	5	0						
Adder entry B	5	1	5	2	5	3	5	4	0	0						
Adder Output	5	3	0	0	0	2	0	3	5	0						

## SUBTRACTION

$$80235 - 67890 = 12345$$

Decimal System							Bi-Quinary System											
	D6	D5	D4	D3	D2	D1	D6		D5		D4		D3		D2		D1	
	B	Q	B	Q	B	Q	B	Q	B	Q	B	Q	B	Q	B	Q	B	Q
Carry	1					1	1											
Adder entry A	0	8	0	2	3	5												
Adder entry B	9	3	2	1	0	9												
Adder Output	0	1	2	3	4	5												
							Above 5											
Carry								1							1	1		
Adder entry A	0	0	5	3	0	0	0	2	0	3	5	0						
Adder entry B	5	4	0	3	0	2	0	1	0	0	5	4						
Adder Output	0	0	0	1	0	2	0	3	0	4	5	0						

Figure IV-1. Bi-Quinary Addition and Subtraction

NOTE: On all additions involving a complement, a *carry* is inserted in the units position.

The digits to be added are presented in bi-quinary form. Each decimal digit is represented by simultaneous B-A information gates on two of the seven bi-quinary lines, one gate on one of the lines of the binary level, and one on one of the lines of the quinary level. The quinary levels are added. In the quinary (base 5 level) the only values possible are 0, 1, 2, 3 and 4. Whenever a quinary sum exceeds 4, a carry into the binary level occurs, the quinary returns to 0 and again begins to advance toward 4.

Each of the two positions in the binary level represents a count of five units. That is, the two binary indications alternate to show whether the value represented by the quinary level is below five (0, 1, 2, 3, or 4) or five and above (5, 6, 7, 8, 9). Because the binary level counts in units of five, any carry from the quinary level to the binary will be a five-unit carry.

Similarly, because the quinary level counts units of one, any carry from a binary level to the quinary of the next digit will be a one-unit carry.

Subtraction is accomplished by adding the complement of the number to be subtracted. In the binary level B0 and B5 are complementary, while in the quinary level Q0 and Q4 are complementary as are Q1 and Q3. Q2 is its own complement. The fact that the two levels are diagonally complementary as shown in Figure IV-2, makes complement entries to the adder quite simple. It is necessary only to allow the information gate from the source to enter the adder on the diagonally opposite adder input lines. The result is the entry of a 9's complement. However (as indicated in the preceding subtraction example, a carry indication is inserted into the adder so that its analysis of the units digit is the same as if a carry had been left over from a preceding digit. This is done on any complement entry and the effect is the same as if a 10's complement had been entered.



### Adder A and B Entry Switching

WD 0-99 shows the different data flow paths, mixing at adder entry switching A, any one of which can supply information to the adder A input lines and the different paths mixing at entry switching B that can supply information to the B input lines. The details of these A and B entry switching circuits are shown in WD 8-00 and WD 8-20. The control gates are developed by the arithmetic control circuits in accordance with the operation being executed. The development of these control gates will be discussed in a later section on arithmetic controls. Thus, for any given arithmetic operation the control gates will select the data flow paths and will open these A and B switching circuits at the proper times and for the necessary intervals to supply information to the adder as required by the operation.

### Adder Circuits

The one-digit adder consists of diode switch and mix circuitry, carry and no-carry latches, binary and quinary output latches, reset controls, carry and no-carry insert controls and adder output latch zero insert controls.

In effect bi-quinary addition tables are built into the adder. For a particular pair of bi-quinary inputs only one bi-quinary output, which is the sum of the inputs, is obtained.

During a digit interval when information is presented to the adder two of the seven bi-quinary input lines, at both A and B inputs, are raised (WD8-10). Either the carry or the no-carry latch will be on as a result of the preceding digit analysis or as a result of a carry or no-carry insert. Quinary inputs are analyzed in the quinary matrix. Similar A and B quinary inputs are mixed to give A or B Q0, A or B Q1, A or B Q2, A or B Q3, or A or B Q4 signals from the cathode followers so labelled. When the A and B quinary inputs are not the same, two of these cathode followers will be energized. All combinations of two of these five cathode followers are switched to operate the quinary sum cathode followers and indicate a quinary sum of 1, 2, 3, 4, 5, 6, or 7. When the A and B quinary inputs are similar they are also switched, and mixed where necessary, to operate the quinary sum cathode followers and indicate a quinary sum of 0, 2, 4, 6, or 8.

The 0, 1, 2, 3 and 5, 6, 7, 8 quinary sums are separately mixed to give *below-5* or *5-and-above* inputs to the binary matrix. The Q4 sum is switched with carry and no-carry signals. These switch outputs are separately mixed into the below-5 and 5-and-above cathode followers. Thus a Q4 sum and no-carry is below 5 while the Q4 sum and a carry is 5-and-above. The quinary sum signals 0 or 5, 1 or 6, 2 or 7 and 4 or 8 are mixed to provide the five signals for operation of the quinary output latches. These signals are all separately switched with carry or no-carry D pulse signals to turn on the quinary output latches.

The three pieces of information necessary for turning on a quinary latch are quinary A input, quinary B input, and carry or no-carry. They are available during the adder entry digit interval and are sampled at the end of this interval with a D pulse. Thus, during D time of the adder entry digit interval, coincidence of signals exists at one of the quinary latch input switches. This positive D pulse output from the switch is inverted to a negative D pulse and applied to the grid of a capacitor-coupled inverter that is normally cut off. A negative output is required from this inverter to pull the latch on. Thus, the latch is turned on not during signal coincidence but when coincidence is removed. This happens with the beginning of the next digit interval as the D pulse and the input and carry or no-carry signals terminate. Signal coincidence was established and then removed from one of the latch input switches, which caused the latch to turn on.

Any adder latches that are on (binary, quinary and carry or no-carry) are reset at A time of every digit interval as long as the adder reset control latch is not on. This reset is done by removing coincidence from the latch back switches with negative A pulses. Whenever it is desired to prevent resetting these latches, the adder reset control latch is turned on. Its output mixes to shunt the negative A pulses and holds the reset line up.

The time constant of the capacitor-coupled inverter grid circuit is sufficient to supply a latch *pull-on* pulse of about 4 microseconds duration. As just explained, this pulse is acting to turn the latch on during the time that the NAP is resetting the latches. However, because the inverter pulse is of longer duration than the NAP, it overrides it, holding the latch on during

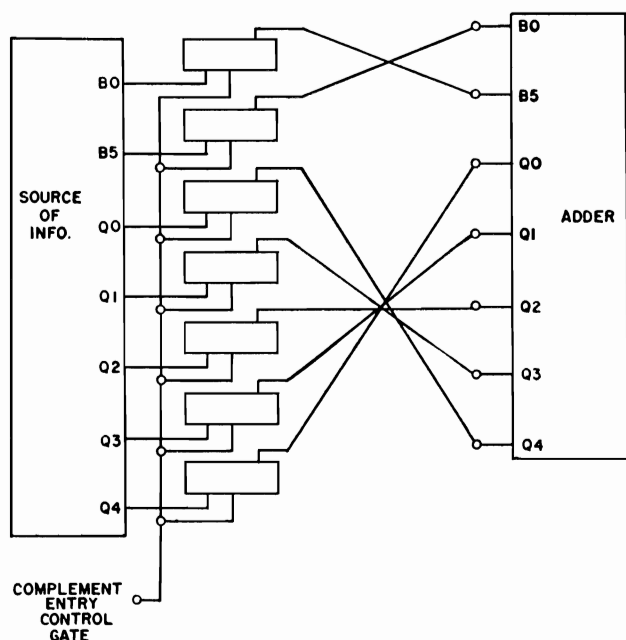

Figure IV-2. Bi-Quinary Complement Entry

the NAP reset time and allowing it to latch back once the latch back circuit is completed at the termination of the NAP.

In this way, information that enters the adder during a given digit time is analyzed, combined with a carry or no-carry indication held over from the preceding digit, and transferred to the output latches at the beginning of the next digit interval. This information in the adder latches is available during the remainder of this *next digit interval*, for transfer to the accumulator, etc.

The information contained in the carry and no-carry latches, regarding the carry or no-carry status of the preceding digit, is used to set up the quinary latch for the next digit at the time when the sampling D pulse terminates. The carry, no-carry latches are, therefore, free at A pulse time, to be reset and set up with new information regarding the carry status of the new digit.

Returning to the adder entry terminals—at the same time that the quinary matrix is being energized by the quinary A and B inputs, the binary matrix is also energized by simultaneous binary A and B inputs. Four pieces of information must be analyzed to determine properly the binary sum and the carry, no-carry condition to be stored for the next digit. These con-

ditions are: adder entry A, adder entry B, below-5, or 5-and-above, and D pulse. Figure IV-3 contains all the possible combinations and outputs. The below-5 and 5-and-above signals are a result of the quinary analysis.

Entry A	Entry B	5 and Above	Below 5	DP	OUTPUT
B5	B0	above 5		DP	B0 Carry
B0	B5	above 5		DP	B0 Carry
B5	B5	above 5		DP	B5 Carry
B0	B0	above 5		DP	B5 No Carry
B5	B0		below 5	DP	B5 No Carry
B0	B5		below 5	DP	B5 No Carry
B5	B5		below 5	DP	B0 Carry
B0	B0		below 5	DP	B0 No Carry

Figure IV-3. Binary Addition Table

The input circuits to the binary latches and the carry and no-carry latches are energized in the same way that the quinary latches were energized.

The quinary latches and binary latches contain the new digit. The new-carry or no-carry indication is stored in the carry or no-carry latches. This new information is available from these latches during the remainder of the next digit interval.

As explained, three input signals are required to energize the binary matrix: a binary A input, a binary B input, and a 5-and-above or below-5 input from the quinary matrix. If any one of these three inputs is blocked, there will be no output from the binary matrix to alter the status of the binary latches or the carry and no-carry latches.

If the blocking inverters associated with the 5-and-above and below-5 amplifiers are caused to conduct, they will block entry of the 5-and-above or below-5 signals to the binary matrix and thus prevent an output signal. This will prevent the status of the carry and no-carry latches from being altered.

This blocking action is used on those occasions where it is desired to prevent the normal resetting of the adder. When the adder reset control latch is turned on, not only is the NAP reset blocked as previously explained, but also the 5-and-above and below-5 blocking inverters are energized by the output of this latch. The carry and no-carry latches are thus protected so they will still contain the carry—no-carry indication of the last digit analyzed, even though several digit intervals pass before analysis of the next digit.

The switch circuitry controlling the adder reset control latch is arranged to turn the latch on from D10bL-D0cU on any operation other than left shift or table lookup. On a left shift operation the latch is turned on from DXbU-D1cU, and on a TLU operation it is prevented from turning on at all.

The need for these adder reset controls is brought about by the two-digit gap in the middle of the accumulator at DXU and D0U. On all arithmetic operations except TLU the accumulator must supply its two words of information to the adder. On all of these operations except left shift the accumulator early output is used. On left shift the on-time output is used.

When the accumulator early output is used to supply the adder, the information to be analyzed must be presented to the adder one digit time early, so that an on-time output will be available from the adder

for storage back in the accumulator. It will be recalled from the discussion of the accumulator that the D1U position is read out at D10L time, and this information is stored in the accumulator early latches, which are not reset until D1aU time. Thus, the D1U information is actually read out three digit times early but is still available for presentation to the adder at the normal one-digit early time, D0U. When this D1U information is accepted by the adder at D0U time, the carry or no-carry information from D10L must still be available for use by the adder in properly analyzing the D1U information.

This information will still be available in the adder carry, no-carry latches if they have not been reset and have not received any new signal. This blocking of any possible alteration of the carry status is accomplished by the Lt Sh Off control of the adder reset control latch.

# SECTION V. FUNCTIONS OF OPERATION CODES

## 10'S AND 60'S CODES

IN CONCEPT, the control commutator can be thought of as a two-branched ring (Figure V-1).

As an example of the operation of the control commutator, assume a series of instructions such as

XX	XXXX	0012
10	0018	XXXX

During an I half cycle, the function of the control commutator is to

1. Find the location 0012 on the drum and read into the program register the instruction 10 0018 XXXX.

2. Signal that the new instruction has been read into the program register in order to cause a D half cycle.

During the D half cycle, the control commutator sets up circuits that accomplish the following:

1. Find the location 0018 and read the data from 0018 into the distributor.

2. Perform the instruction 10 (add upper) using the data in the distributor.

3. Signal that the operation 10 has been set up in order to cause another I half cycle.

In the two-branch ring illustrated schematically, the amount of time necessary to complete each ring must vary. The cyclical nature of the 650, in which instruction and data words may be in any of 50 locations around the drum, makes necessary a flexible control system. Thus, after an I half cycle is started, its length depends on the location of the new instruction. Similarly, the length of a D half cycle varies

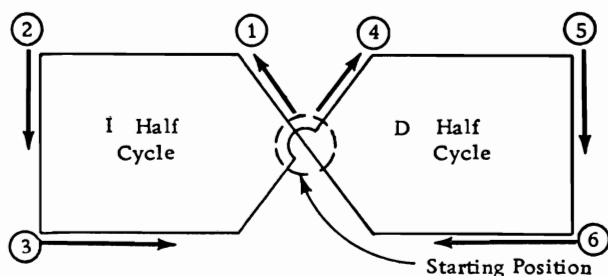

Figure V-1. Control Commutator

according to the location of the data and the type of operation being performed.

Another factor in the operation of the control commutator is the somewhat different operation for different operation code numbers. The 650 operation codes can be divided into the following groups:

00, 01	No-op and STOP codes
10's and 60's	Arithmetic codes
20's	Store codes
30's	Shift codes
40's and 90's	Test codes
70's	Input-output codes
84	TLU

The action of the control commutator is the same on the I half cycle for all of these groups. On the D half cycle the method of operation varies with the operation code. Control commutator principles and circuits will first be described in detail for a 10 code (add upper) operation. Later, the operation of the control commutator will be described for the other groups of codes.

### Control Commutator

Before studying commutator operation, the student should be familiar with the operation code register, address register, program register, and distributor.

### I HALF CYCLE (Figure V-2)

#### Major Objective:

Enter the next instruction word into the program register.

#### Minor Objectives:

1. Reset operation code and address registers. (Restart A).
2. Transfer next instruction address (D1 through D4) from the program register to the address register. (Restart B).
3. Search for the next instruction word.
  - a. I Control
  - b. Enable Read-In
  - c. Start Read-In

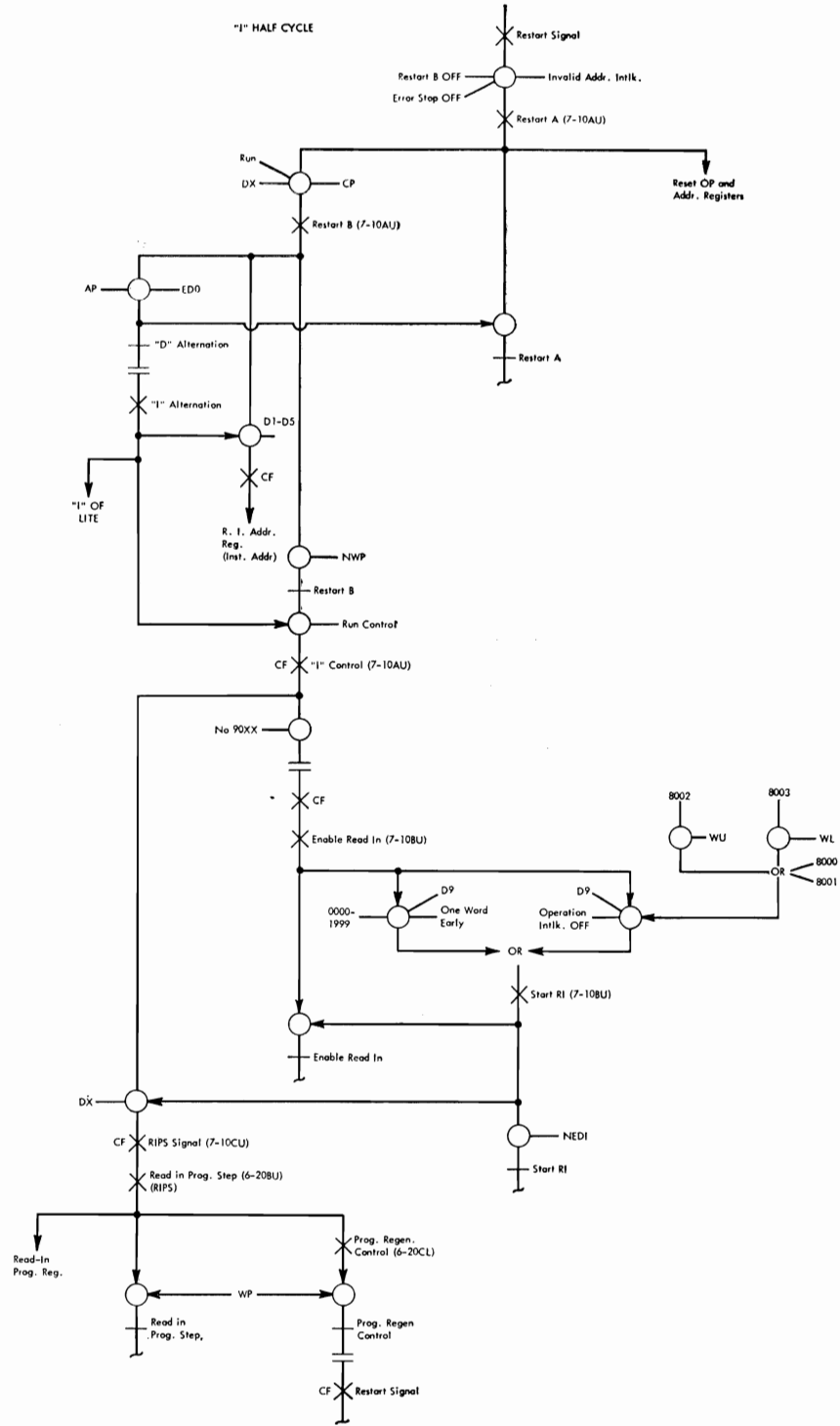

Figure V-2. I1 Half Cycle

4. Read instruction word into the program register.

a. Stop program register regeneration

5. Restart signal to start the D half cycle.

Figure V-3 shows the commutator operation for a specific set of program steps. With this set of program steps, the word time at which each latch operates is predetermined. During word times 0011, 0012, and 0013, the I half cycle occurs.

The following circuit elements function on every I half cycle.

#### Restart A

The restart signal to turn on restart A can occur at any digit time and at any word time, dependent only on the operation code being performed on the previous D half cycle. In Figure V-3, it was assumed that restart A was turned on during word time 0010. The function of the restart A is to reset the operation code register and address register and to store the restart signal so that the restart B latch can be turned on at the beginning of the next word time.

#### Restart B

The restart A latch being on at the start of any word time will result in turning on the restart B latch. The purpose of restart B on an I half cycle is to cause the r-address of the instruction in the program register to transfer to the address register.

#### Enable Read-In

As soon as the r-address of the instruction in the program register has been placed in the address register during restart B time, the output of the address register attempts to develop a one-word-early D9 gate. If the r-address is 0013, one-word-early D9 would occur during 0012 word time. In order for the one-word-early D9 gate to be recognized, it is necessary to turn on an enable read-in latch. This latch must be on a minimum of one word time, if a drum address is in the address register. It could be on as long as 50 word times if the drum address of the example were 0012 instead of 0013. The example illustrates optimum programming, because the enable read-in latch is on for only one word time. Enable read-in is turned on when restart B goes off.

#### Start Read-In

The next step in the sequence of operating the RIPS gate is to turn on the start read-in latch. This is done at D9 time whenever enable read-in is on and a one-word-early D9 gate is developed.

#### Read-In Program Step

Whenever the start read-in latch is on at DX time during an I half cycle, a read-in program step signal will be developed. This signal turns on a latch that remains on for one word time so that the contents of drum location 0013 may enter the program register.

#### Circuit Description of the Alternation Control Latches (WD 7-10)

Assume that the D alternation latch is to be turned off, and the I alternation latch is turned on.

The restart B output switches at 9C diodes 1, 2, 4 with a ED0 AP to provide a pulse to turn off the D alternation latch, and turn on the I alternation latch so that an I half cycle can take place. The ED0 AP output at 9C pin 3 is inverted by an IN503 unit at 9B. The negative pulse output then breaks the latch back of the D alternation latch at 11G diodes 11, 12.

When the D alternation latch goes off, a capacity-coupled positive pulse from pin 7 of 11 H turns on the I alternation latch. The capacity-coupled input pulse to the I alternation latch lasts longer than the ED0 AP to the latch back at 11G pin 6. The I alternation latch stays on until another restart B signal allows the control latches to again reverse their status.

#### D HALF CYCLE 10'S AND 60'S CODES

(Figure V-4)

As is indicated by Figures V-2 and V-3, the completion of the I half cycle when the RIPS gate ends, results in the restart signal, which initiates a D half cycle.

Major Objectives (Figures V-3 and V-4):

1. Search for the data
2. Perform the operation

Minor Objectives:

1. Reset operation code and address registers
2. Transfer operation code and data address (D5 through D10) from the program register to the operation register and address register respectively.

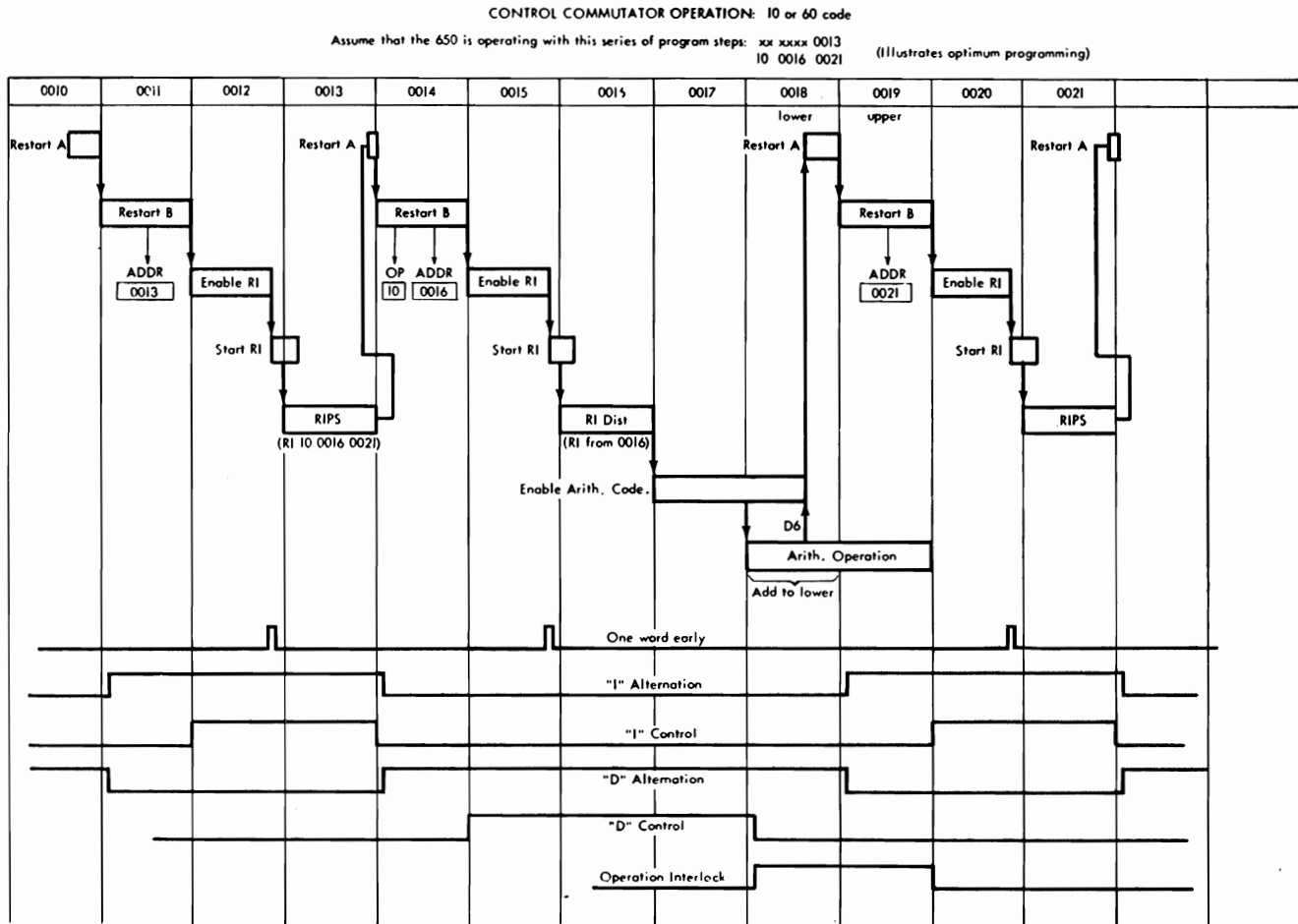

Figure V-3. Control Commutator Operation—Code 10-60's

3. Search for the data address
    - a. D control
    - b. Enable read-in
    - c. Start read-in
  4. Read data into the distributor
    - a. Stop distributor regeneration
  5. Distributor back signal
    - a. Restart signal to start the I half cycle on a code 69
    - b. Advance control commutator through remainder of the D half cycle
  6. Perform the operation—Add, Subt., Mult., Div.
  7. Restart signal to start the next I half cycle
- On Figure V-3 the data search is accomplished during word times 0014, 0015, and 0016. Note that this represents optimum programming because enable

read-in must be on at least one word time. Any other location for the data would result in a slower operation. During word times 0018 and 0019, the accumulator is in operation and the actual addition to the upper accumulator takes place during word time 0019. A signal at D6 time of word 0018 initiates a new I half cycle by turning on restart A.

The following circuit elements function on the first part of every D half cycle:

*Restart A.* This latch functions as in I half cycle, except that the pulse to turn it on comes from a different source.

*Restart B.* The restart A latch being on at the beginning of any word time will result in restart B turning on for one word time. When the restart B latch goes on, it allows the alternation control latch to flip from I to D.

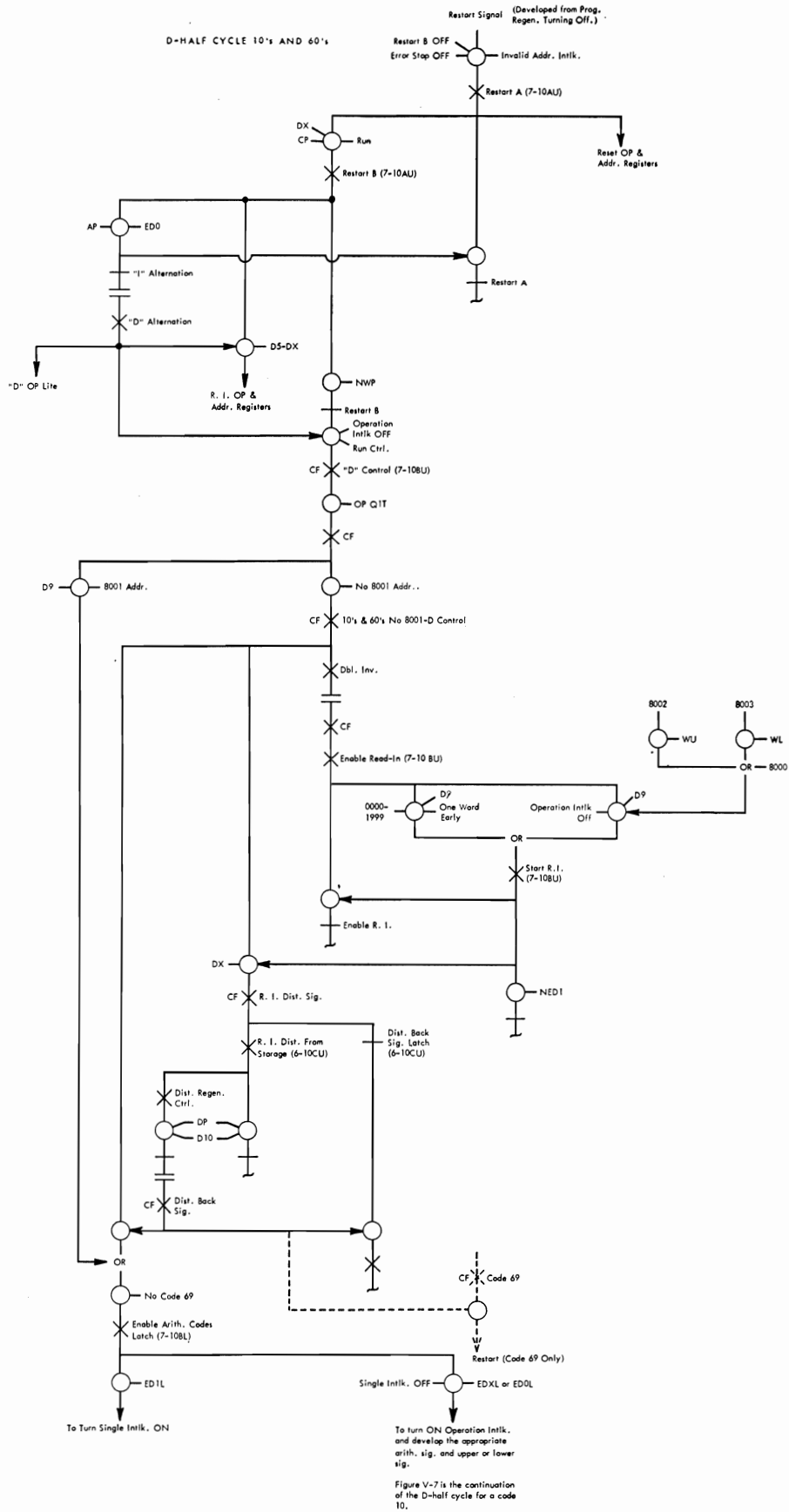

Figure V-4. D Half Cycle—Code 10-60's



*D Alternation and D Control.* When restart B goes on, the alternation control latch, which had been at I is flipped to D. As restart B goes off, D control is turned on. The D alternation latch being on makes possible the read-in of the operation code and the D-address into the operation code register and the address register during restart B time. Also, the fact that D control is on allows the enable read-in, start read-in sequence to result in a read-in distributor signal instead of a read-in program step signal as on the I half cycle. The development of D control initiates a circuit to test the operation code. Refer to Figure V-3 to see the timing of D control and D alternation.

*Enable Read-In.* As soon as the D-address of the instruction in the program register has been placed in the address register during restart B time, the output of the address register attempts to develop a one-word-early D9 gate.

In the example, one-word-early D9 occurs during word time 0015.

*Start Read-In.* As in an I half cycle, the enable read-in latch output switches with a D9, one-word-early D9 and no 800X address to turn on start read-in.

*Read-In Distributor.* Whenever start read-in is on at DX time during a D half cycle, the read-in distributor signal will be developed. The read-in distributor latch turns on for one word time so that the contents of location 0016 may enter the distributor.

The following circuit elements function on the second part of every D half cycle:

*Distributor Back Signal.* The distributor back signal, which occurs as the distributor regeneration control latch goes off after the new data have entered the distributor, causes the control commutator to advance through the remainder of the D half cycle.

*Enable Arithmetic Codes Latch.* This latch causes the operation code to be examined and forces the 650 to wait for a lower word time before allowing the accumulator to go into action. The enable arithmetic codes signal, which is developed from the enable arithmetic codes latch, switches with the output of the operation code register to develop an add signal and an upper signal so that the add upper instruction will be performed.

*Arithmetic Operation Latch.* The development of an add signal (on a 10 or 60 code) will result in turning on the arithmetic operation latch. Once on, this latch controls the restart signal to signal the 650 to begin the next I half cycle. Also, interlock circuits are operated to prevent another accumulator operation until the present one is completed.

The arithmetic and shift operations make use of the accumulator and distributor and may require several word times for their completion. The restart signal on these operations is developed during the first word time of the operation. Thus, the commutator can advance concurrently with the performance of the operation and allow the next instruction to be located and read into program step storage. A restart for the D half cycle and a transfer of the new operation code and the D-address to the operation and address registers can take place. At this point, further advance of the commutator cannot be allowed until the preceding operation is completed.

Single interlock (WD 7-10CL) turning on prevents more than one testing of the operation code.

Operation interlock (WD 7-10CL) turning on prevents the development of a second D control until the accumulator and distributor have completed their operation. Operation interlock also prevents the development of a start read-in signal if the address is 800X. When an arithmetic or shift instruction has an 800X I-address, the locating of the next instruction must be prevented until the preceding operation is complete, because the instruction itself is in the process of being developed by the operation.

## Code 69 (Load Distributor) (Figure V-5)

### Major Objective:

To read the contents of the D-address into the distributor.

### Circuit Operation:

The action is similar to the 10's and 60's code D half cycle except that only the enable read-in, start read-in sequence is performed. Energization of the enable arithmetic code latch is blocked and the distributor back signal causes a restart to I signal. Note that an operation code of 69 will always be accompanied by a no 8001 address.

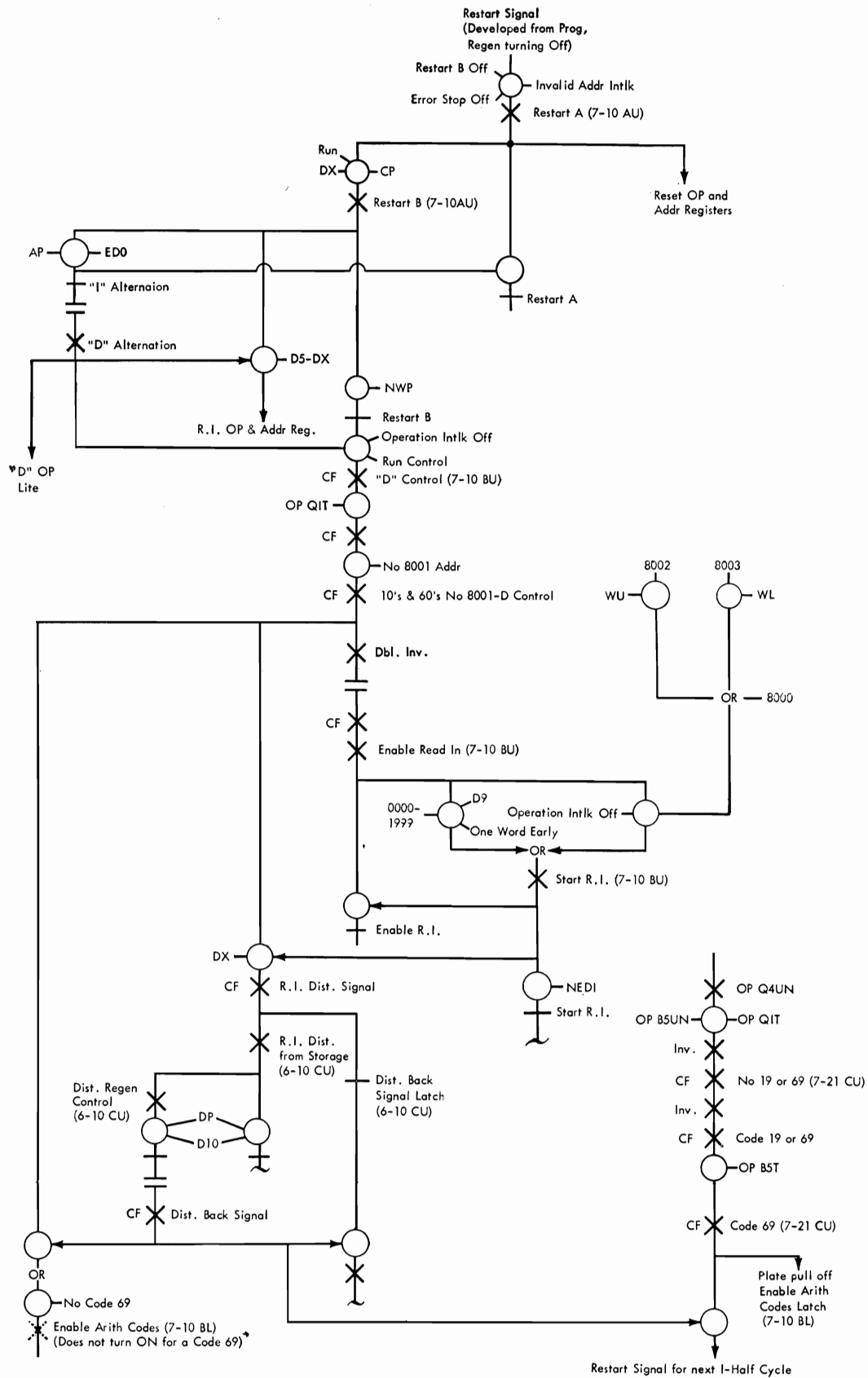

Figure V-5. D Halt Cycle—Code 69

Plus Distributor and Plus Accumulator

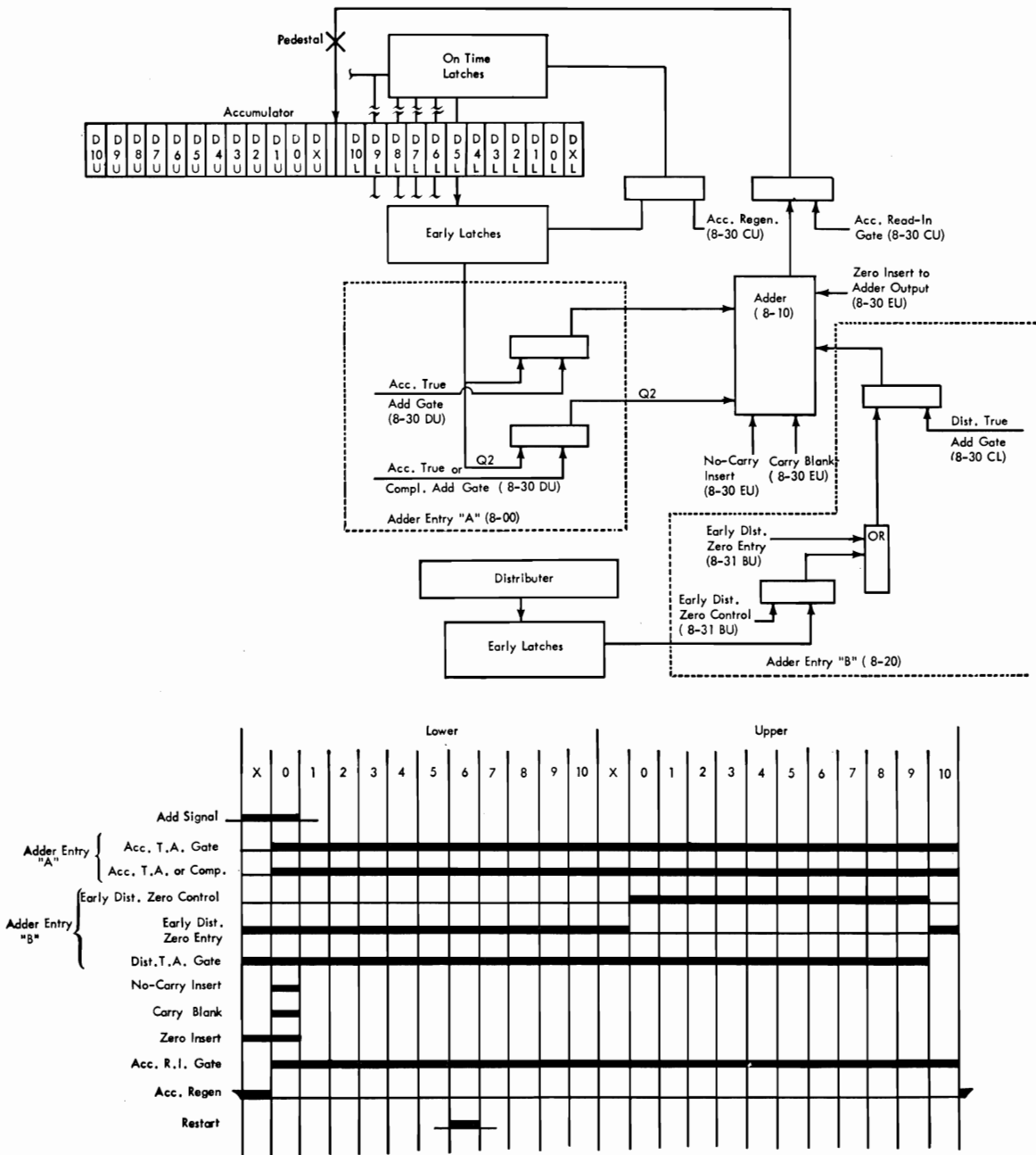

Figure V-6. Add Upper—Code 10

## ADDITION AND SUBTRACTION OPERATIONS

AN add or subtract operation is accomplished by merging the two accumulator words in the adder with the distributor output and one word of zeros. On an add or subtract upper operation the lower accumulator word will merge with zeros, and the upper, with the distributor output. On an add or subtract lower, zeros will be merged with the upper accumulator word, and the lower accumulator will merge with the distributor. A sign analysis (Figures V-11 and V-12) will indicate whether the accumulator and distributor entries are to be true or complement and will set the accumulator sign latches to indicate properly the sign of the sum.

### Code 10 AU (Add to Upper Accumulator) (Figures V-6 and V-7)

(Assume that the accumulator and distributor are plus.)

**Major Objective:** Add the D-address contents to the upper accumulator contents

**Minor Objectives:**

1. Read the D-address contents into the distributor.
  - a. Refer to D half cycle 10's and 60's codes.
2. Entry A:
  - a. Read accumulator contents into the adder.
    - (1) Accumulator true add gate.
    - (2) Accumulator true-or-complement add gate.
      - (a) Used for Q2 bits; since Q2 is its own complement.
3. Entry B:
  - a. True add distributor or zeros.
    - (1) Distributor true add gate.
  - b. Read distributor contents into the adder (during upper word).
    - (1) Early distributor zero control.
  - c. Supply zeros to the adder (during lower word).
    - (1) Early distributor zero entry.
4. Set no-carry condition in the adder.
  - a. No-carry-insert and carry-blank.
5. Enter adder output into the accumulator.
  - b. Accumulator read-in gate.

c. Block accumulator regeneration.

(1) Zero-insert at D0L

(a) To satisfy validity

(2) Zero-insert at DXL

(a) A zero-insert is developed at DXL to satisfy validity on a reset code, for example code 60 RAU. Accumulator regeneration is turned off at DXL on a *reset* code.

6. Advance the control commutator to the next I half cycle.

a. Restart Signal.

The 10's and 60's operation is preceded by a control commutator enable read-in, start read-in sequence, which places the data in the distributor. A distributor back signal at the completion of the distributor read-in, turns on the enable arithmetic codes latch whose output switches with single interlock off, EDXL and ED0L to provide a gate from DXL to D1L to energize the arithmetic operation code analysis circuits. Each arithmetic operation will start at the beginning of the lower word time with the DXL and D0L add, subtract, multiply or divide signals and the DXL upper or lower signals energizing the arithmetic control circuits. Of course, other signals, such as *absolute*, *no absolute*, *reset* and *no reset*, will be available continuously as long as D control is up.

### Code 60 Reset and Add Upper

(Assume that the distributor is plus)

**Objectives:**

1. Reset the accumulator to plus zero.
2. Read the D-address contents into the upper accumulator.

**Description:**

The normal add operation (code 10) is modified to substitute zeros for the accumulator output in adder entry A.

**Circuit Description**

The circuit operation is similar to that of a code 10, except that a reset signal replaces the no-reset signal. The reset signal switches with the add-or-subtract signal to reset the accumulator sign latches, and to turn on the reset operation latch at DXL (WD 8-30DL). The reset operation latch provides

CODE 10 OPERATION DIST. PLUS ACC. PLUS

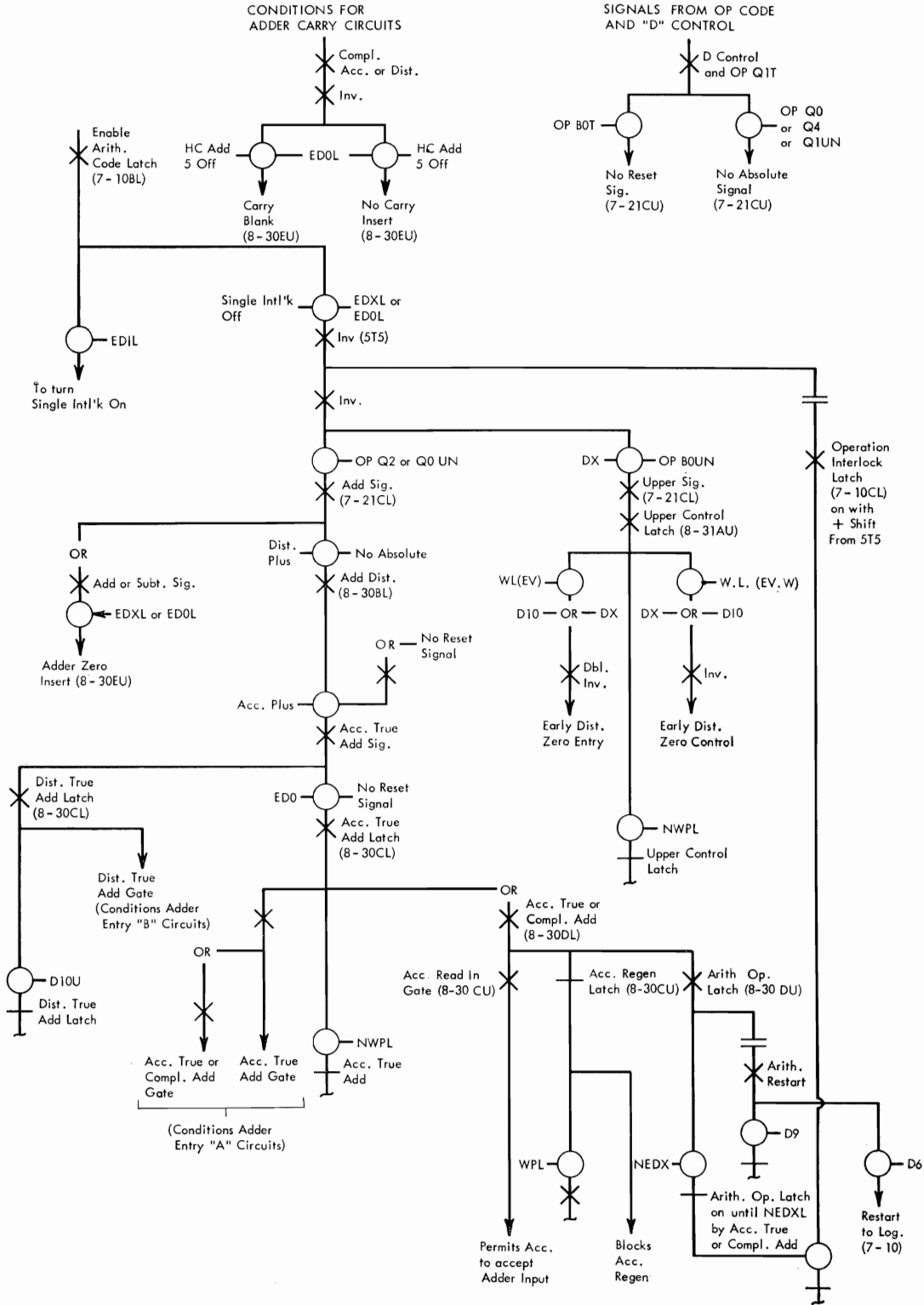

Figure V-7. Add Upper Function Chart—Code 10

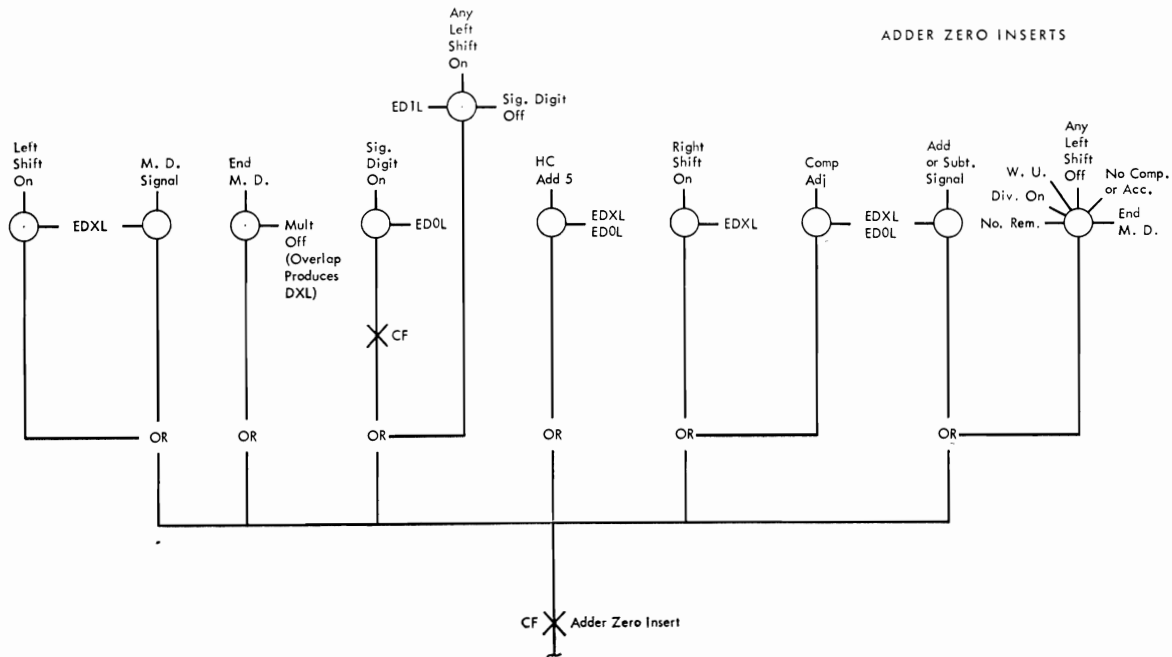

Figure V-8. Adder Zero Inserts

the reset—no reset check, brings up the B0 and Q0 lines of adder entry A (WD 8-00), turns on the arithmetic operation latch, develops the accumulator read-in gate, and turns accumulator regeneration off.

NOTE: The accumulator regeneration is turned off at DXL with a code 60, rather than at D0L for a code 10. Therefore, a zero insert at DXL is needed to satisfy validity. The zero insert at D0L causes no error because the B0 and Q0 adder output latches would be turned on at D0L anyway.

Figure V-8 indicates the possible adder zero inserts.

Figure V-9 indicates the various carry no-carry inserts.

### Code 11 SU (Subtract From Upper Half of Accumulator) (Figure V-10)

The contents of the location specified by the D-address are subtracted from the contents of the upper half of the accumulator. The sign of the result will be determined by an analysis of the operation code, sign of the distributor, sign of the accumulator, and, if necessary, the presence or absence of an accumulator overflow.

### Accumulator Sign Read-Out

The sign of the accumulator is not held in capacitor storage but is stored in the accumulator sign latches. These latches are set up when an accumulator entry is made.

WD 0-99 shows how accumulator on-time outputs are available for display or for entry to the distributor from D1 through D10 time. At D0 time either a B5 and Q4 or a B5 and Q3 must be supplied, depending on whether the accumulator plus or minus sign latch is on. Normally the sign of the accumulator applies to both the lower and upper. Therefore these B5-Q4 or B5-Q3 indications must be supplied at both D0L and D0U times so that a sign indication will be available for display or distributor entry, regardless of which half of the accumulator is being read-out.

The accumulator sign read-out circuitry is shown in WD 8-30EL. These objectives are accomplished by the switch-mix circuitry, which develops D0L and D0U gates on either the accumulator plus read-out or the accumulator minus read-out line. The D0L and D0U gates are sent to selected storage switching on chassis 2 (WD 5-00), where an accumulator plus read-out raises the B5-Q4 lines and an accumulator minus read-out raises the B5-Q3 lines.

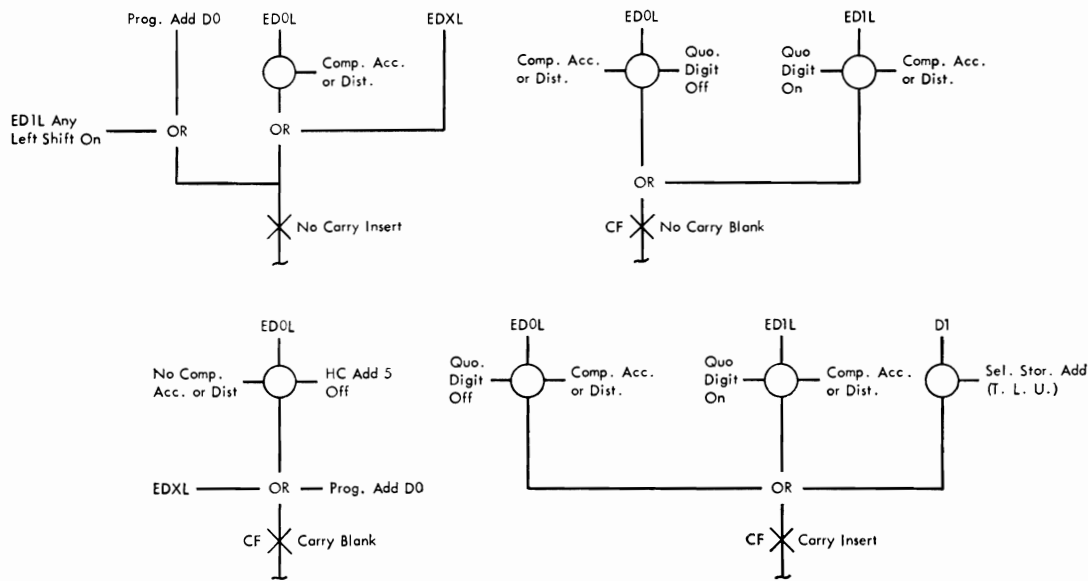

Figure V-9. Adder Carry—No-Carry Inserts

Sign Analysis for Add and Subtract Codes

On an add or subtract operation, in order to determine the proper combination of true or complement entry to the adder, it is necessary to analyze.

1. Algebraic sign of the operation code
2. Is it a reset or no-reset operation
3. Is it absolute or no-absolute
4. Distributor sign (if no-absolute)
5. Accumulator sign

Figure V-11 is a sign analysis chart for no-reset codes, and Figure V-12 is for reset codes. When an add or subtract operation with no-reset is programmed, either the accumulator true-add latch or the accumulator complement-add latch and either distributor true-add latch or the distributor complement-add latch are turned on. Programming a reset add or a reset subtract operation will turn on only the distributor true-add latch or the distributor complement-add latch. The absence of a no-reset signal prevents the accumulator true-add latch from turning on.

Note that when a reset add or reset subtract is programmed, the accumulator sign is reset to plus; therefore the sign analysis will be based on a plus accumulator only.

The sign analysis charts of Figures V-11, V-12 and V-13 show the factors that must be considered by the sign analysis circuits and the way these factors are analyzed.

Complement Result Operation

The various combinations of operation code, distributor sign, and accumulator sign will determine the type of entry into the adder on add and subtract operations. If either entry is to be complement, as indicated by either a distributor complement or accumulator complement signal, the sign of the result will not be known until the operation is complete. The result must then be analyzed for a true or complement condition. This is done by checking for a carry or no-carry from D10U.

A carry means the result is a true number and therefore plus. No-carry means the result is a complement and therefore minus. When any complement entry is indicated, both accumulator sign latches will be turned off. A carry from D10U (plus result) will then turn the accumulator plus latch on. No-carry from D10U (minus result) will indirectly cause the accumulator minus latch to be turned on.

When the result in the accumulator is complement, as indicated by no-carry, an additional complement adjust cycle must be taken during which the complement number in the accumulator is run through the adder as a complement entry and merged with zeros substituted for the distributor value. This converted number is read into the accumulator where it is available for further use. A no-carry condition turns on the complement adjust latch, to initiate a

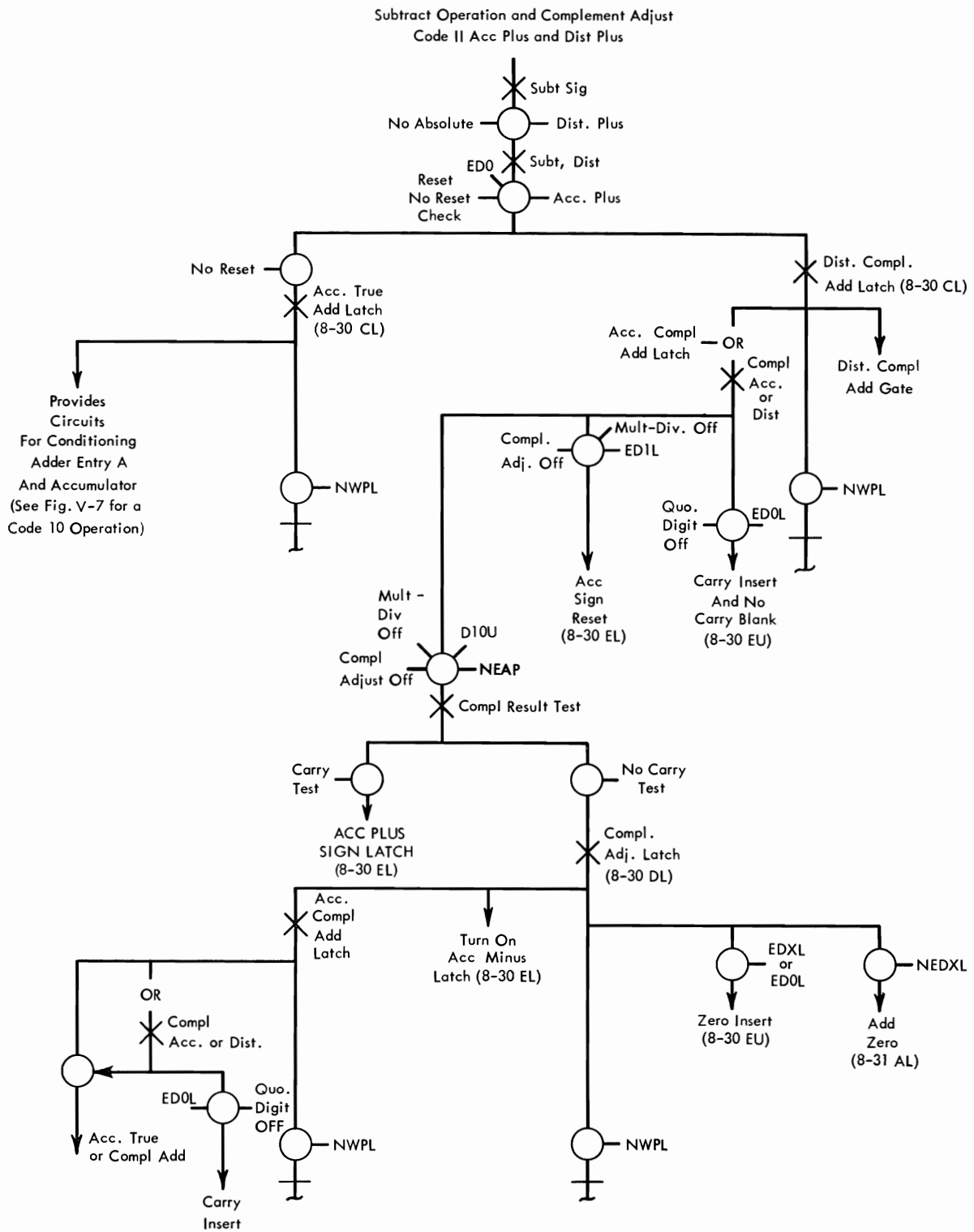

Figure V-10. Subtract and Complement Adjust



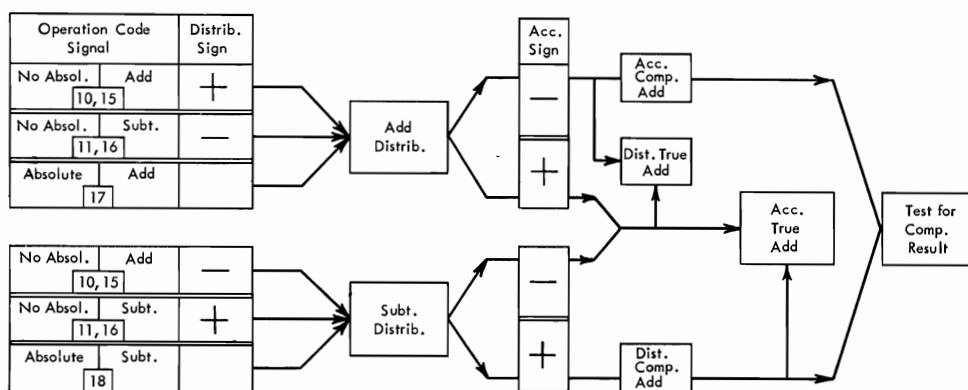

Figure V-11. Sign Analysis Chart—No-Reset

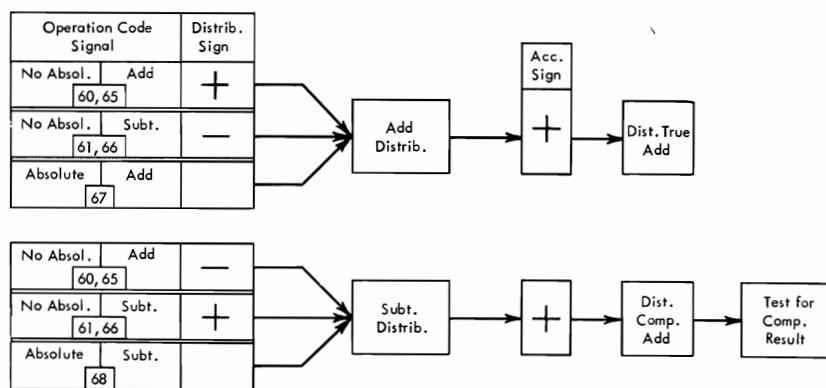

Figure V-12. Sign Analysis Chart—Reset

complement adjust cycle. The complement adjust latch also turns on the accumulator minus sign latch.

### NO OPERATION, STOP AND STORE CODES

No Op and Stop Codes 00 and 01  
(WD 7-10, 7-21 Figure V-14)

On a 00 no operation the D-address of the instruc-

tion is ignored. It is necessary only to develop a restart signal and proceed with the next program step as specified by the I-address (refer to Figure V-15).

On a 01 stop operation a restart must be developed, but the run latch must also be turned off so that calculation will stop at the end of the next restart word with the I-address in the address register and

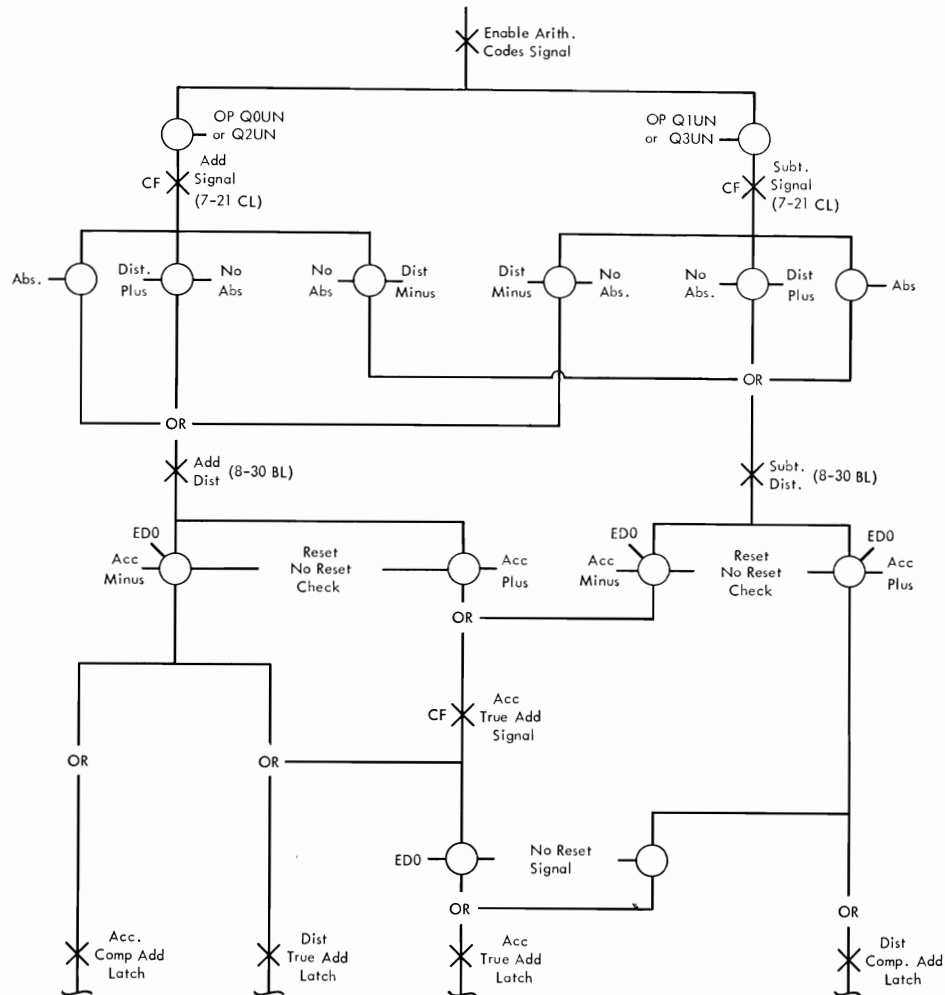

SIGN ANALYSIS FOR ADD AND SUBTRACT  
Codes 10, 11, 15, 16, 17, 18, 60, 61, 65, 66, 67, 68

Figure V-13. Sign Analysis for Add and Subtract: Function Chart

the control commutator ready to continue on the interrupted I half cycle (refer to Figure V-16).

**Major Objective:**

Stop the control commutator just before I control of the next I half cycle.

**Minor Objectives:**

1. Advance the control commutator into the I half cycle.
  - a. Restart signal

2. Block I control

a. Turn off run latch

Sensing an 01 in the operation register with D control on turns off the run latch if the programmed-stop switch is set to STOP. At the same time, the restart signal is developed to advance the control commutator through restart B time of the next I half cycle. If the programmed-stop switch is set to RUN, an 01 code is treated as a no operation code.

Assume that the 650 is operating with the following series of program steps:

xx xxxx 0013  
00 0000 0017

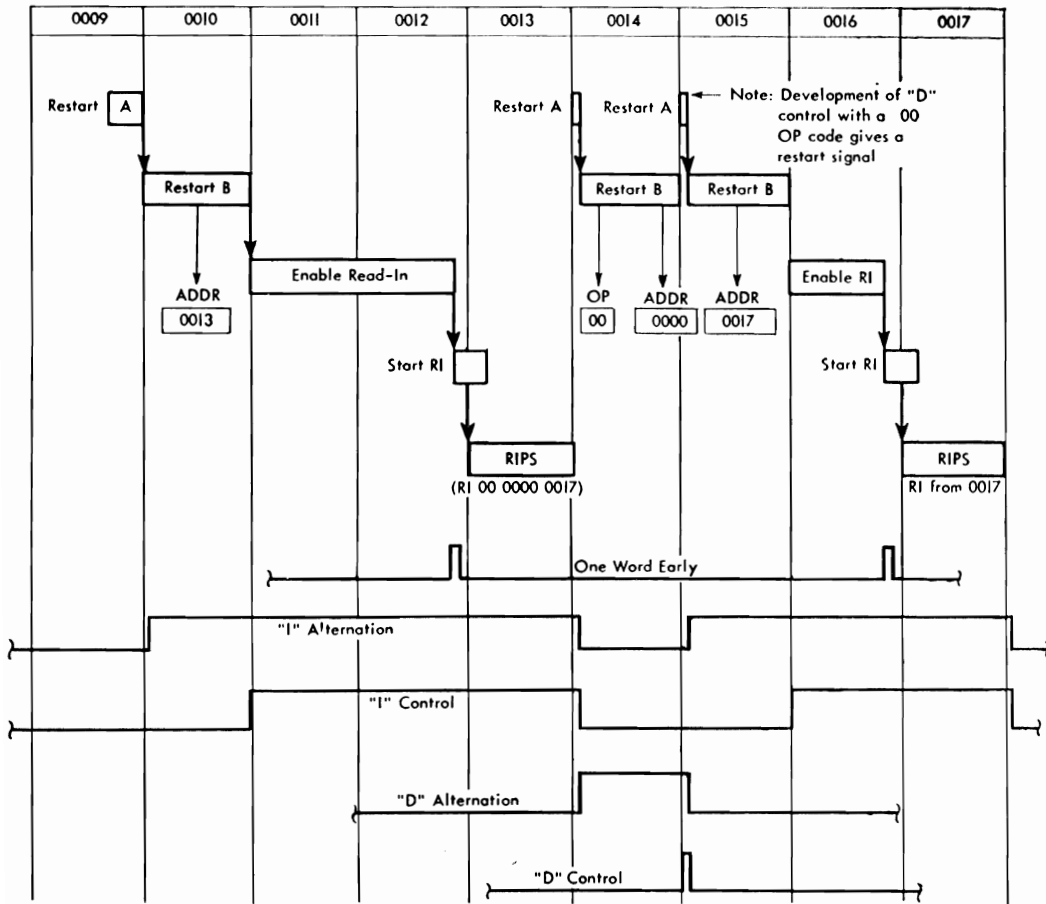

If the 650 is operating with the following series of program steps, then the operation is changed as shown here

xx xxxx 0013  
01 0000 0017

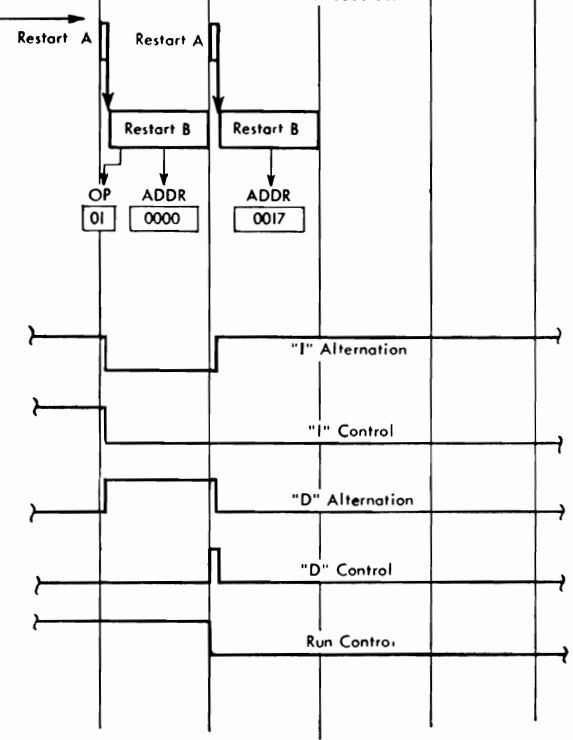

Figure V-14. Control Commutator Operation—Code 00 & 01

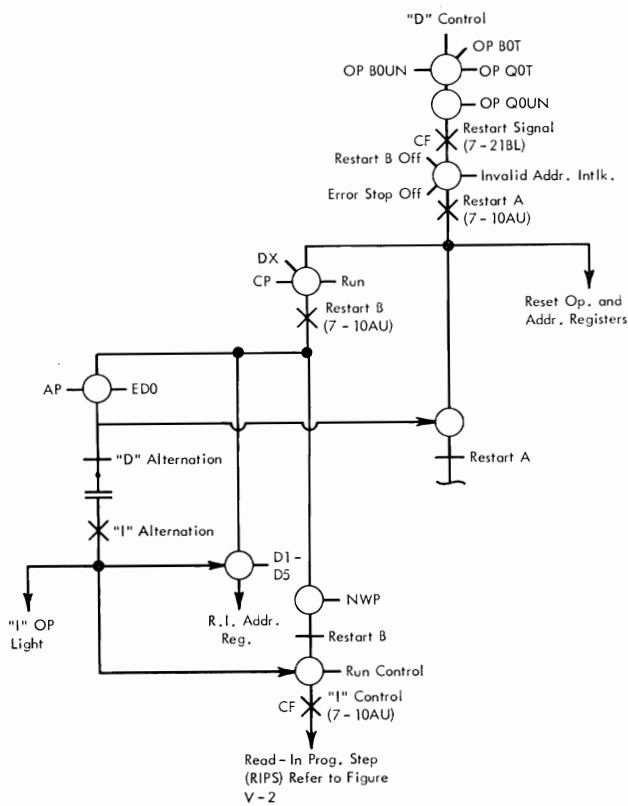

Figure V-15. No Operation—Code 00

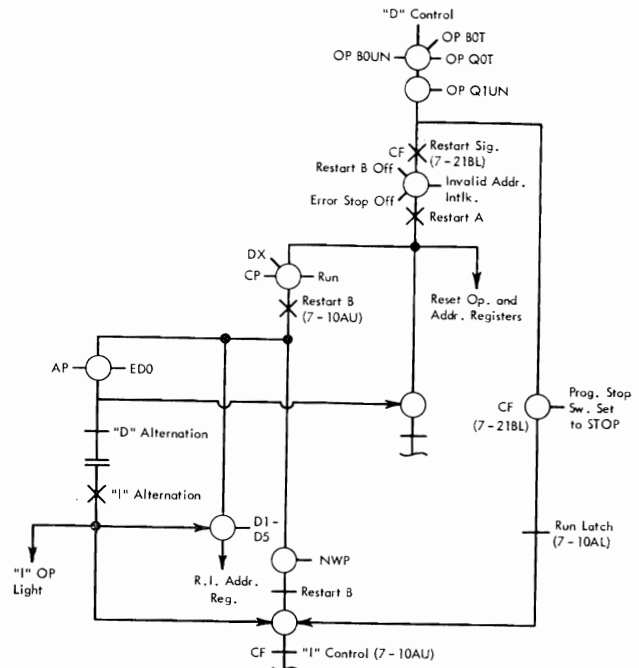

Figure V-16. Stop Code—Code 01

CONTROL COMMUTATOR OPERATION: 20 Code STL

Assume that the 650 is operating with this series of program steps: xx xxxx 0005 0123456789 in upper accumulator  
20 0011 xxxx

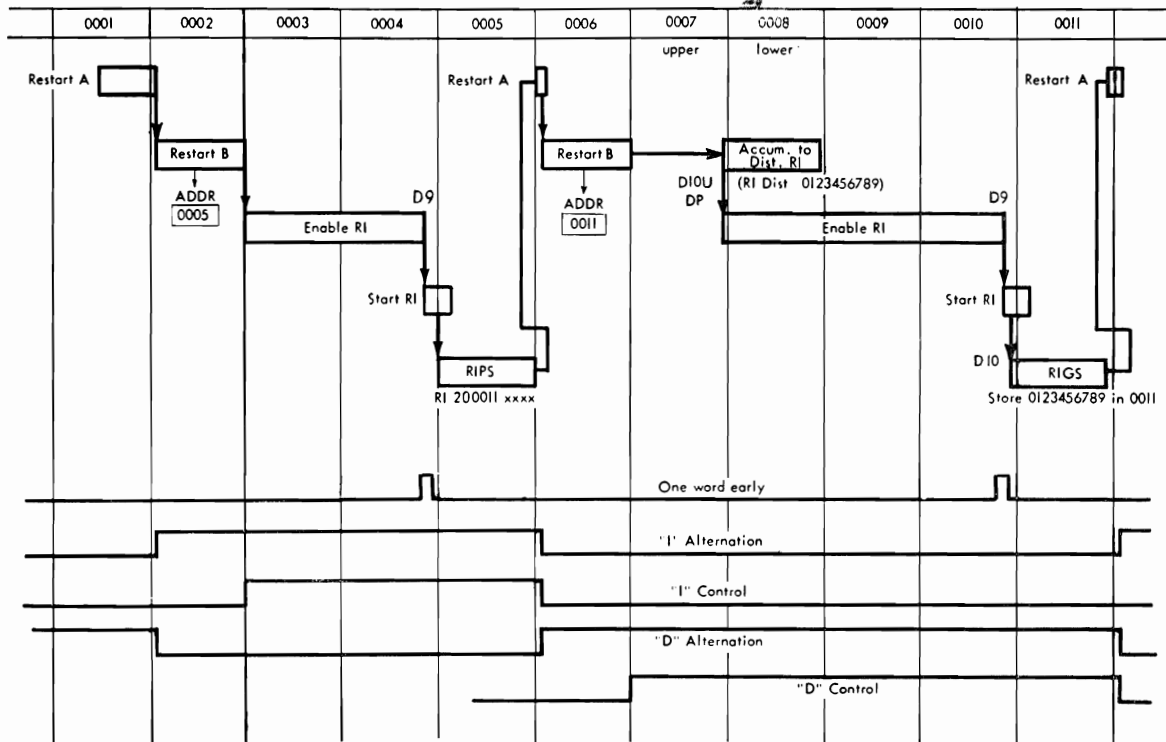

Figure V-17. Control Commutator Operation—Code 20

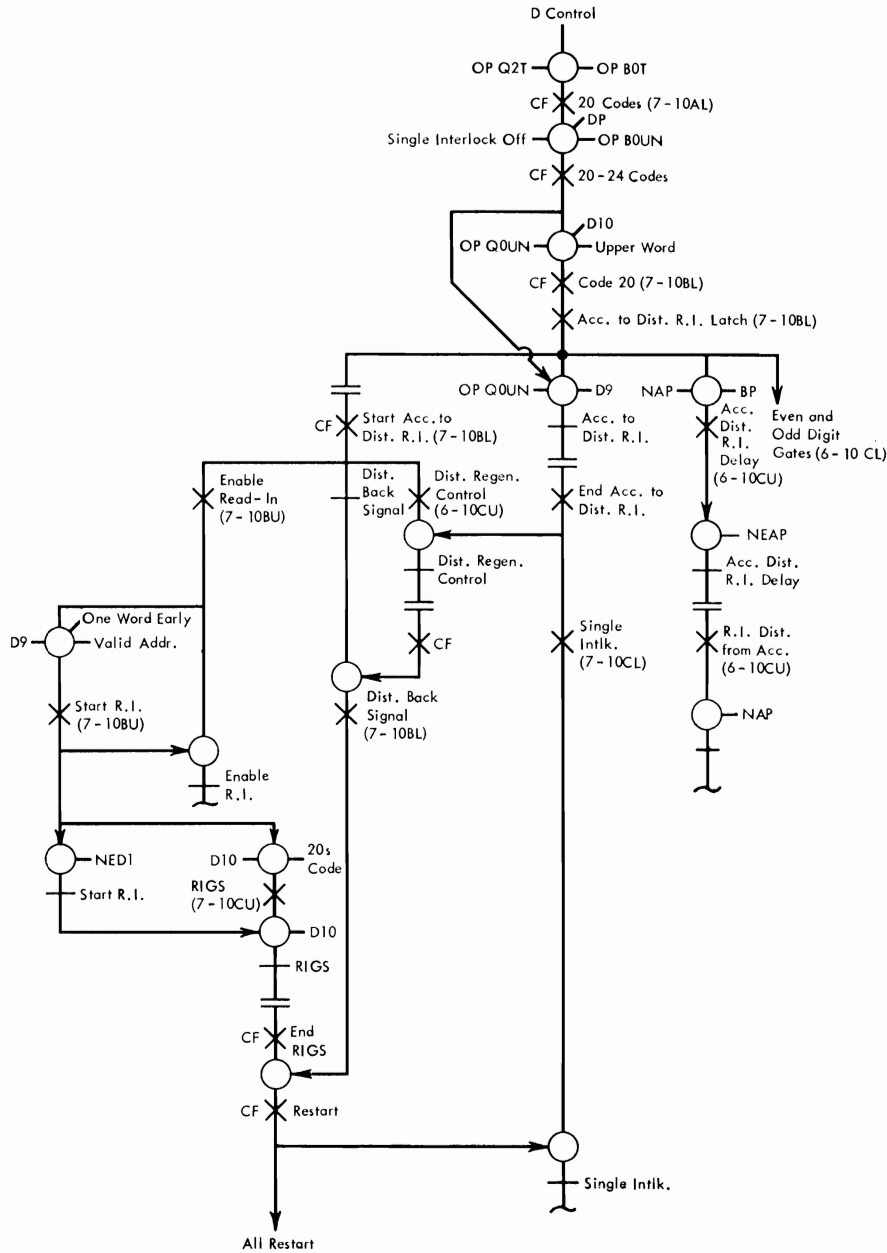

Figure V-18. Store Lower Accumulator—Code 20

Store Codes (20's) (WD 7-10, 7-21)

Objectives:

The store codes provide a means of transferring information from arithmetic storage in the accumulator or distributor to general storage. A store operation code is always accompanied by a general storage *D*-address. The store operations have the common characteristic that the number stored is also in the distributor after completion of the operation. The

number contained in a memory location is automatically erased as new information is read into it. The contents of the accumulator is not affected by this operation. The *D*-address specifies the location in which the number is to be stored. The next instruction is taken from the location specified by the *R*-address. A brief description of the store codes follows:

*ST L* Store Lower Half of Accumulator (20).  
Major Objective (Figures V-17 and V-18):

The contents of the lower half of the accumulator

and its sign are stored in the location specified by the D-address.

**Minor Objectives:**

1. Transfer the contents of the lower accumulator to the distributor.
  - a. Accumulator to distributor read-in latch (on D10L-DP off D9-DP)
    - (1) Single interlock prevents accumulator to distributor latch from going on a second time.
  - b. Distributor regeneration control latch.
  - c. Accumulator to distributor read-in delay latch.
  - d. Read-in distributor from accumulator latch.
2. Transfer the distributor contents to a specified general storage location.
  - a. Enable read-in start read-in sequence
  - b. Read-in general storage latch
3. Restart signal to advance control commutator
  - a. End RIGS signal when read-in general storage latch goes off at D10

**Flow Path of Store Codes**

A transfer from the accumulator to general storage is accomplished by first transferring the data from accumulator to distributor and then from distributor to general storage. On these operations, the direct data flow path from accumulator on-time output to distributor read-in switching is used.

To do this the control commutator must, upon sensing a store accumulator code, develop an accumulator to distributor read-in control gate for the proper upper word, lower word, or portion of a lower word. Concurrently with the development of this gate, it must also initiate an enable read-in, start read-in sequence that will allow the one-word-early signal to time the development of RIGS gate. This RIGS gate will then allow the transferred information to enter general storage from the distributor. It will be seen that an enable read-in, start read-in sequence, in combination with a 20's code, will result in turning on the RIGS latch instead of the development of a RIPS or R. I. distributor signal as in the previous cases.

*ST U Store Upper Half of Accumulator (21).* The contents of the upper half of the accumulator and its sign are stored in the location specified by the D-address.

*ST DA Store Data Address (22).* The digits in positions 5-8 of the distributor are replaced by the corresponding digits in the lower half of the accumulator. The modified number in the distributor is then stored in the location specified by the D-address.

*ST IA Store Instruction Address (23).* The digits in position 1-4 of the distributor are replaced by the corresponding digits in the lower half of the accumulator. The modified number in the distributor is then stored in the location specified by the D-address.

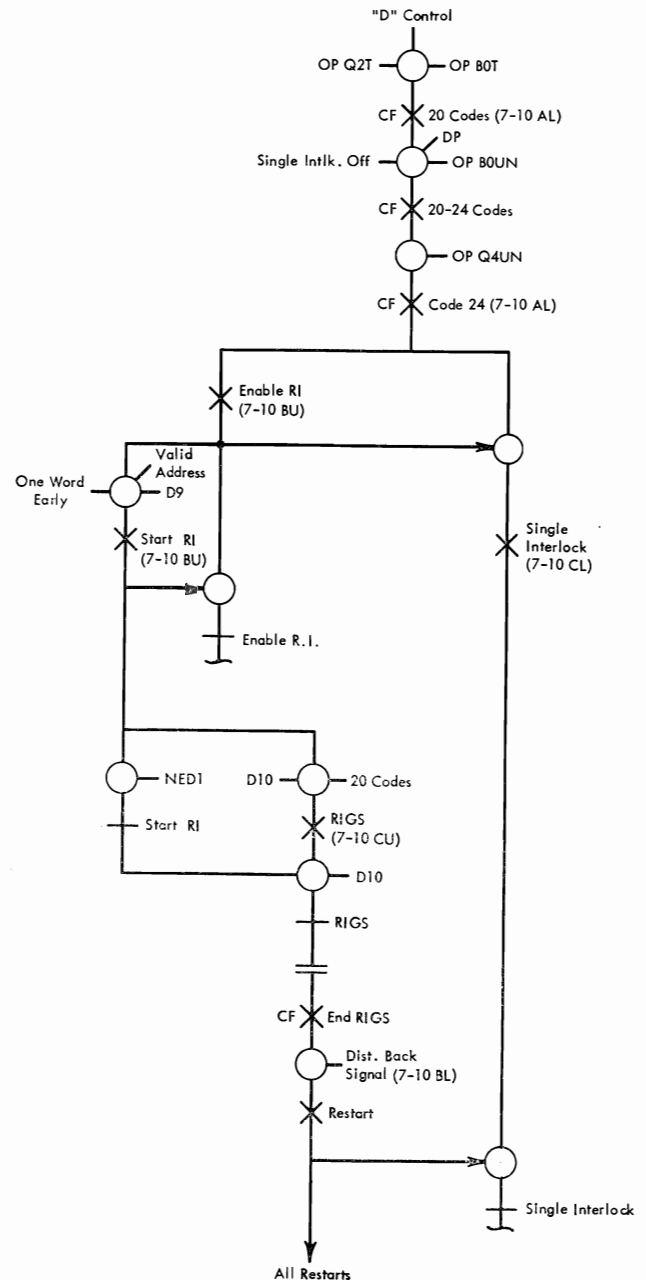

Figure V-19. Store Distributor—Code 24

*ST D Store Distributor (24)* (Figure V-19). The contents of the distributor are stored in the location specified by the D-address.

If a store distributor code (24) is sensed, the accumulator to distributor control is not developed. Instead the enable read-in, start read-in sequence is started. This results in the development of a RIGS gate and the entry into general storage of the data already in the distributor.

### SHIFT CODES (30, 31, 35 and 36)

THE FOUR SHIFT operations, shift right (Code 30), shift right and half correct (Code 31), shift left (Code 35), and shift left and count (Code 36) are all performed by repositioning the digits stored in the accumulator. No transfer of data between storage locations is required. The program control circuits sense the shift code and send a properly timed signal indicative of the shift operation to the arithmetic controls. Restart from a shift operation is similar to an arithmetic operation, and operation interlock is required because the performance of a shift operation may require several word times.

When the shift code is 30 or 35 the program controls must also determine whether or not the shift number (units position of address register) is zero. If it is zero, no signal is sent to arithmetic controls and a restart is developed.

Proper timing of the shift signals is accomplished by the shift control latch. It must be remembered that the D control signal, developed when restart B goes off, starts at the beginning of a word interval, but the word could be either upper or lower. All shift operations start at lower word time. The shift control signal is timed to occur just prior to the beginning of a lower word and insures that the signals will be developed during a lower word interval.

The units digits of the D-address of any shift instruction specifies the number of shift cycles. The calculator will shift the contents of the entire accumulator only by the amount indicated by the units digit.

The next instruction is taken from the location specified by the I-address. The contents of the distributor are not affected by these operations. Any digits shifted off are lost, and no indication is given if this should occur.

### Code 30 SRT (Shift Right) (Figures V-20, V-21 and V-22)

#### Major Objective:

The contents of the accumulator are shifted to the right the number of places specified by the units digit of the D-address. A zero indicates a shift of no positions, a one indicates a shift of one position, etc.

#### Minor Objectives:

1. Enter the ten's complement of the shift number (the units position of the address register) into the accumulator (D0L position).
  - a. Shift number gate at DXL, on first shift cycle only.
  - b. No-carry at DXL.
  - c. Special digit add 1 at DXL.
  - d. Accumulator read-in at DXL.
2. Supply zeros to accumulator.
  - a. Zero insert at DXL.
3. Shift each position of the accumulator, except D0L, one position to the right.
  - a. Right shift gate (D1L-DXL).
  - b. Turn off accumulator regen. latch.
4. Advance the shift number by one.
  - a. Accumulator true add at DXL.
  - b. No carry at DXL.
  - c. Special digit add 1 at DXL.
  - d. Accumulator read-in at DXL.
5. Stop shifting.
  - a. D0L carry.
  - b. Turn on accumulator regen. latch.
  - c. Turn off operation interlock.

Right shifting is accomplished by allowing each accumulator early-digit output to control the pedestal lines. Thus D2L is read out at D1L time, controls the pedestals and reads back into the D1L position at D1L time. Each digit successively follows this procedure for the two accumulator word times, with the result that the accumulator number is shifted one position to the right. The number of shifts taken is controlled by the value of the units position of the D-address (in the address register), which accompanies the shift operation code. Each shift requires two word times, and in the following descriptions each of these two-word intervals is called a *shift cycle*.

On the first cycle of each shift operation the units position of the address register enters the adder at

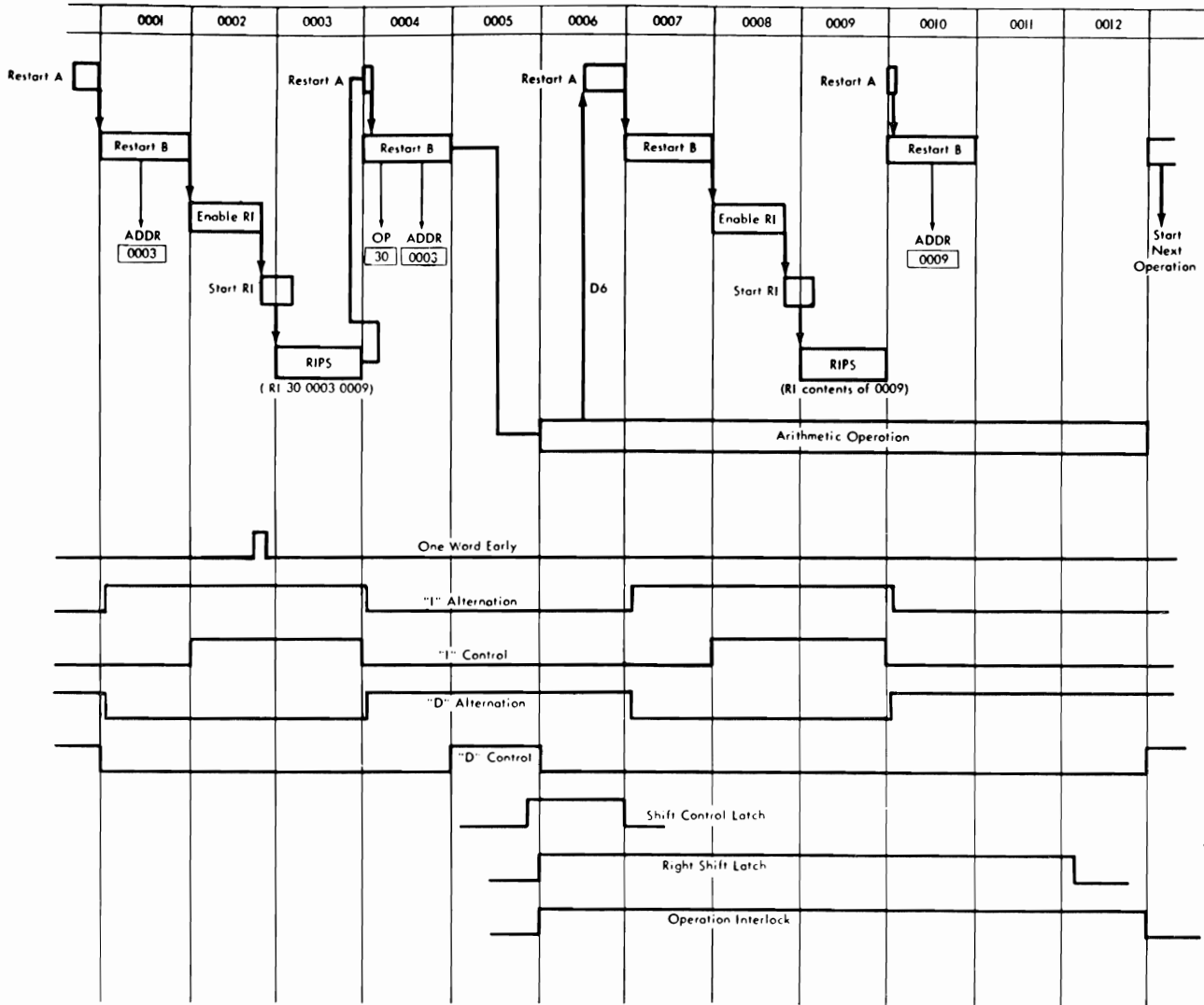

Figure V-20. Control Commutator Operation—Code 30

DXL time in complement form and merges with a one supplied by energizing the special digits add one circuit. This sum, the 10's complement of the shift number, is stored in the D0L position of the accumulator. On subsequent shift cycles the D0L position of the accumulator enters the adder at DXL time, merges with a special digit one and stores back in the D0L accumulator position. In this way the shift number is advanced by one at the beginning of each shift cycle. A carry from the adder at D0L time stops the shifting.

#### Code 31 SRD (Shift and Round) (Figures V-23, V-24 and V-25)

**Objectives:**

1. To shift the contents of the accumulator to the

right the number of places specified by the units digit of the D-address.

2. Half-adjust the units position.

Shift and round is accomplished in much the same manner as right shift except that a shift-count of nine is detected at DXL time of the last shift cycle. This indication sets up circuits that allow the D1 position to shift into D0 position on the last shift cycle and cause an extra cycle to be taken. This extra cycle is a half-correction cycle during which five is added to the contents of D0L and any carry is reflected into D1L of the accumulator. The operation ends at the end of the half correction cycle. As in right shift the units position of the address register controls the number of shifts to be taken.



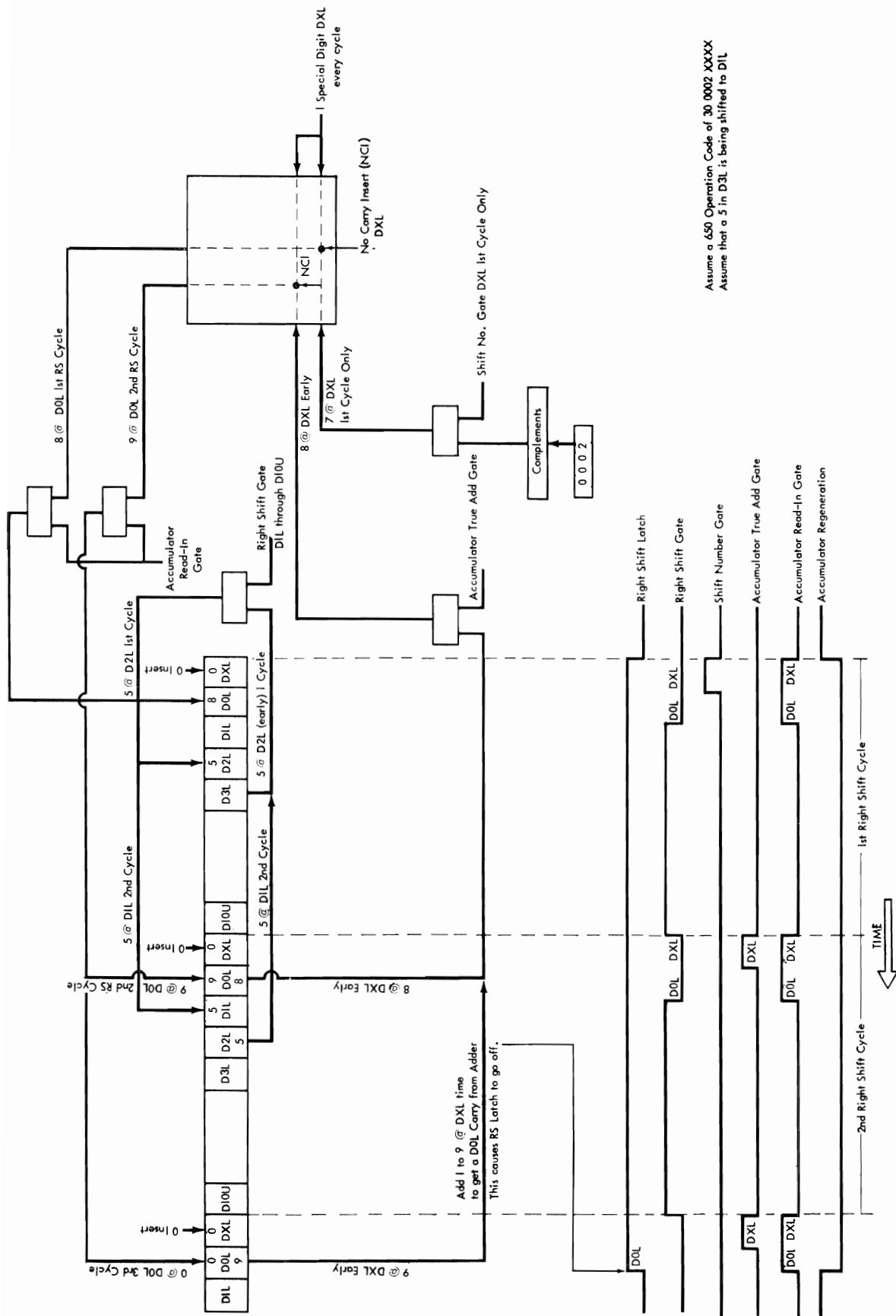

Figure V-21. Shift Right: Block Diagram—Code 30

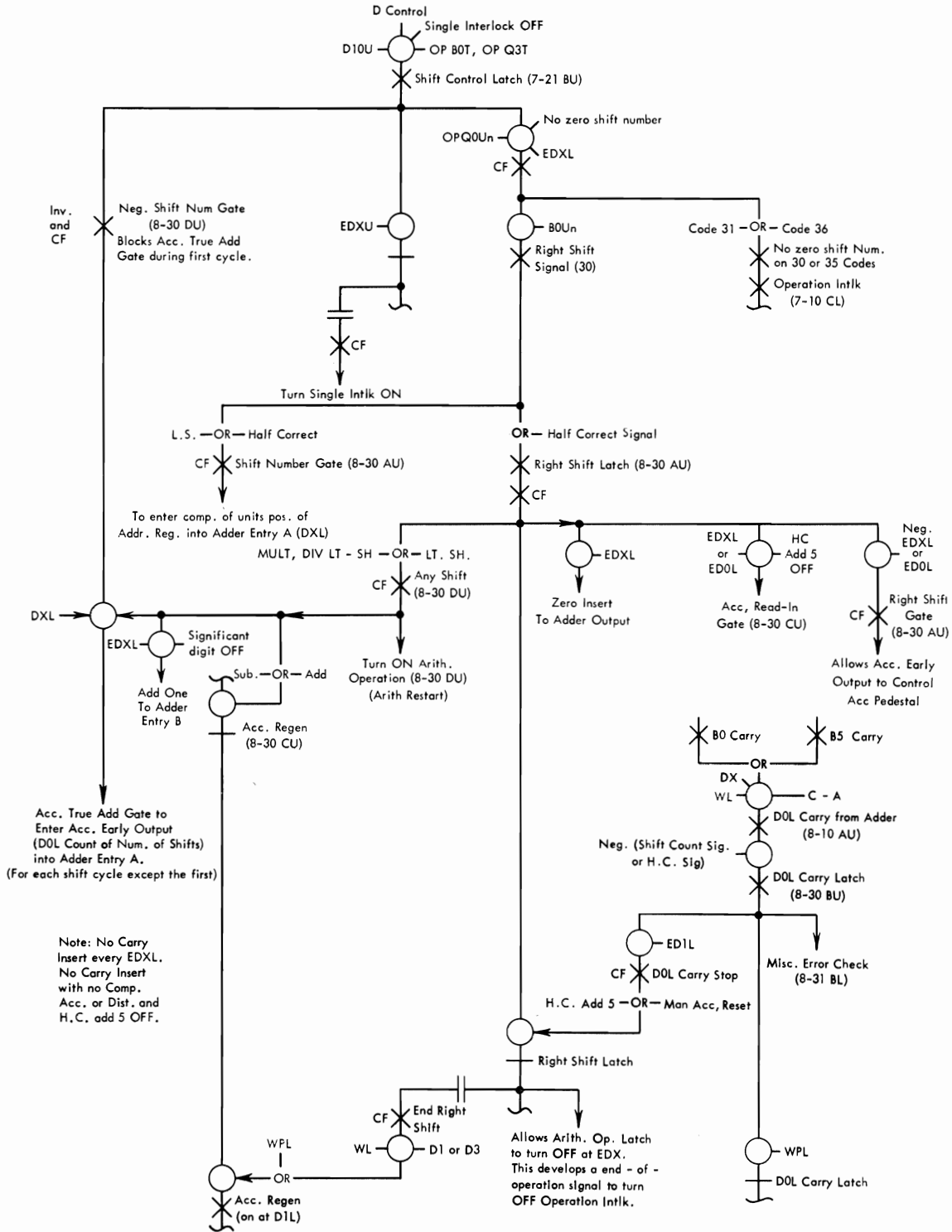

Figure V-22. Shift Right: Function Chart—Code 30



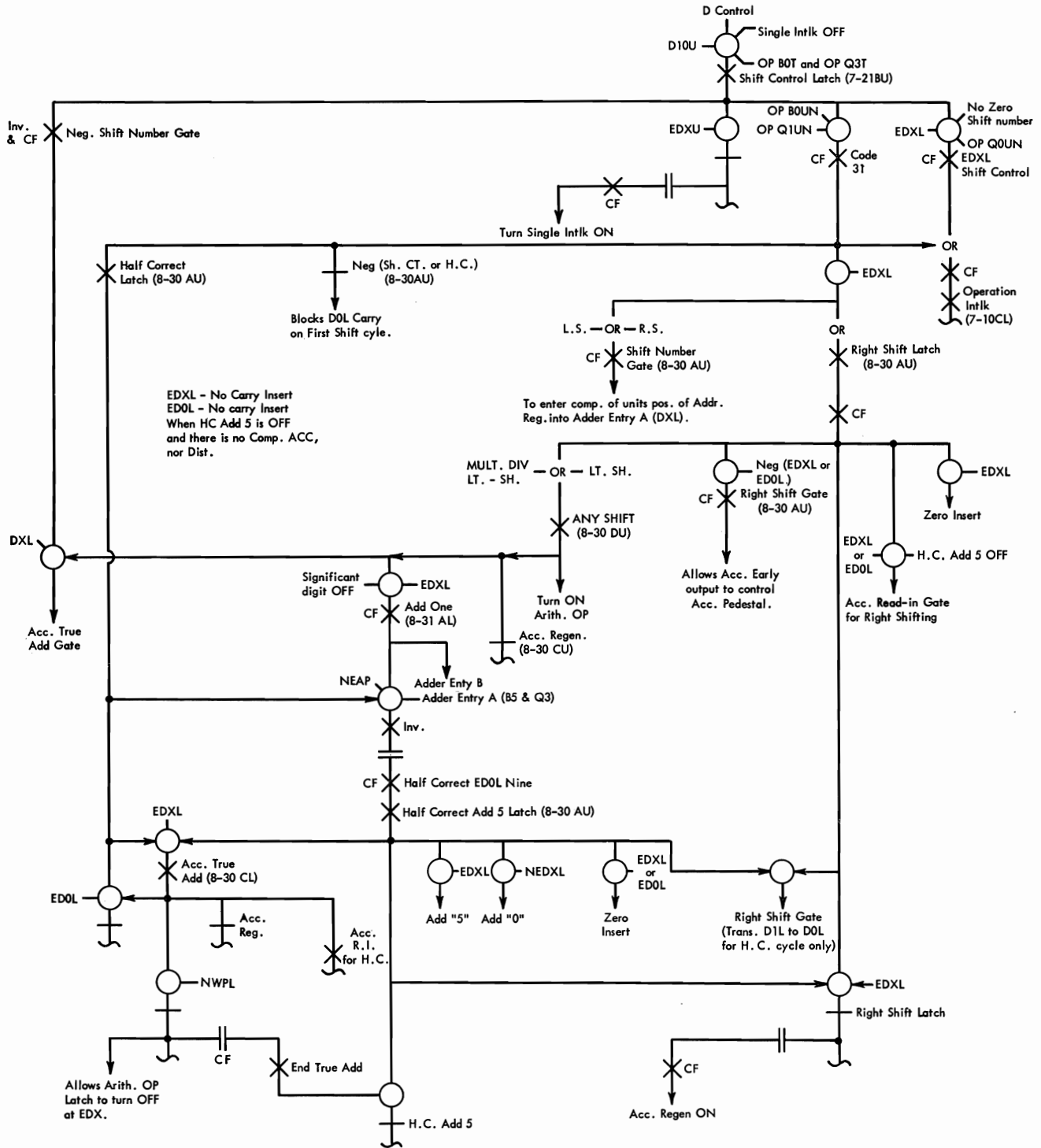

Figure V-24. Shift Right and Round: Function Chart—Code 31

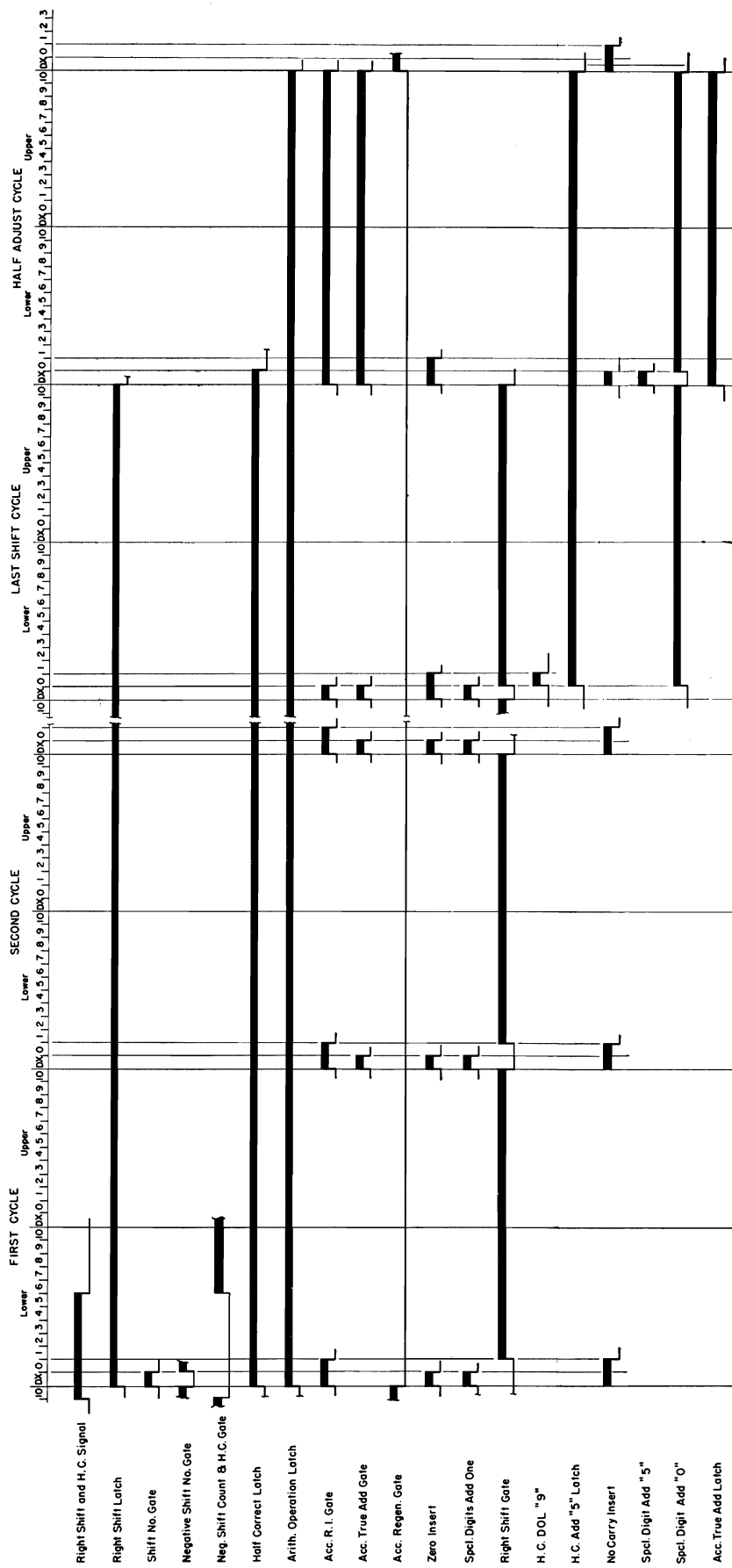
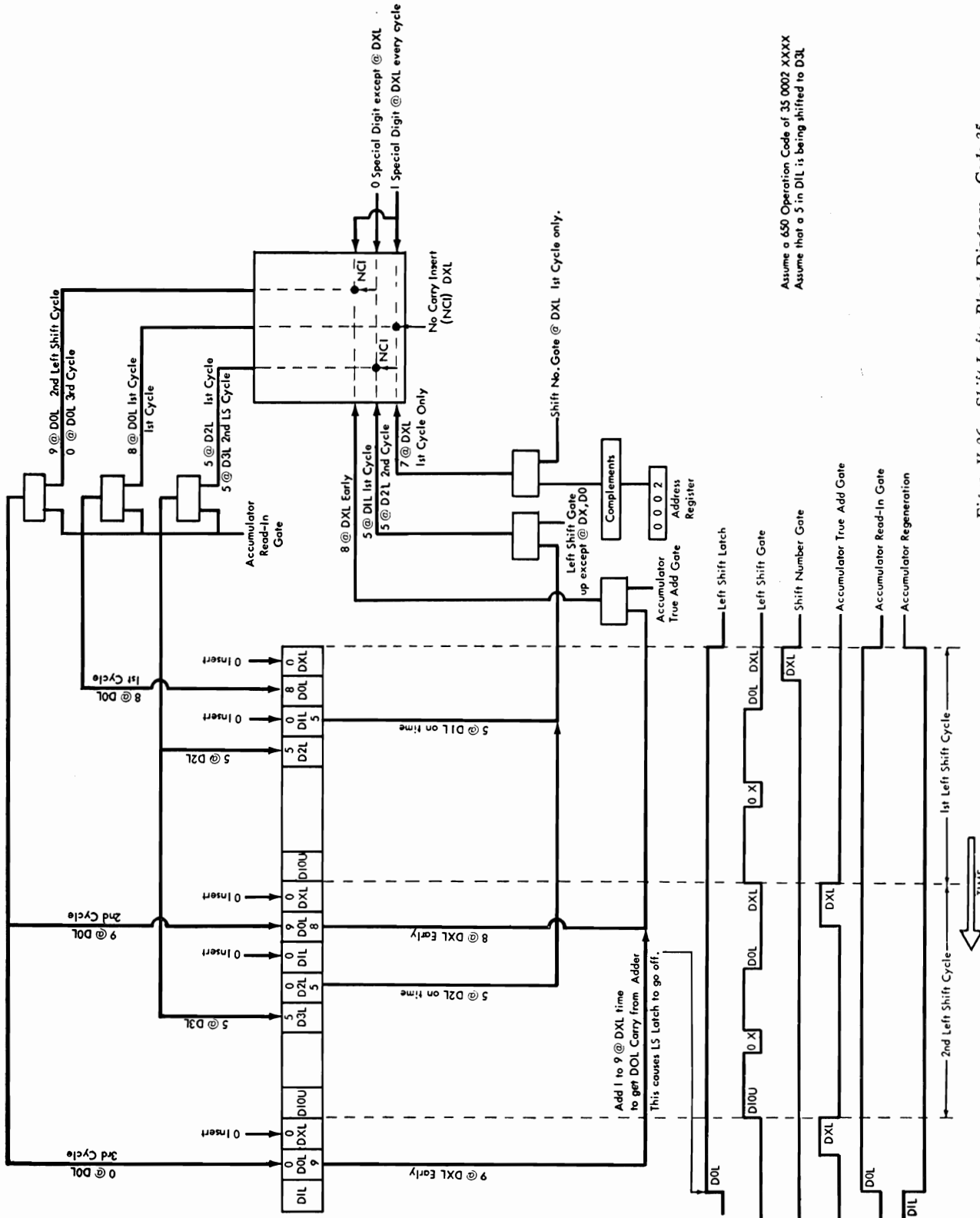

Figure V-25. Shift Right and Round: Timing Chart—Code 31



Assume a 650 Operation Code of 35 0002 XXXX  
 Assume that a 5 in DIL is being shifted to D3L

Figure V-26. Shift Left: Block Diagram—Code 35

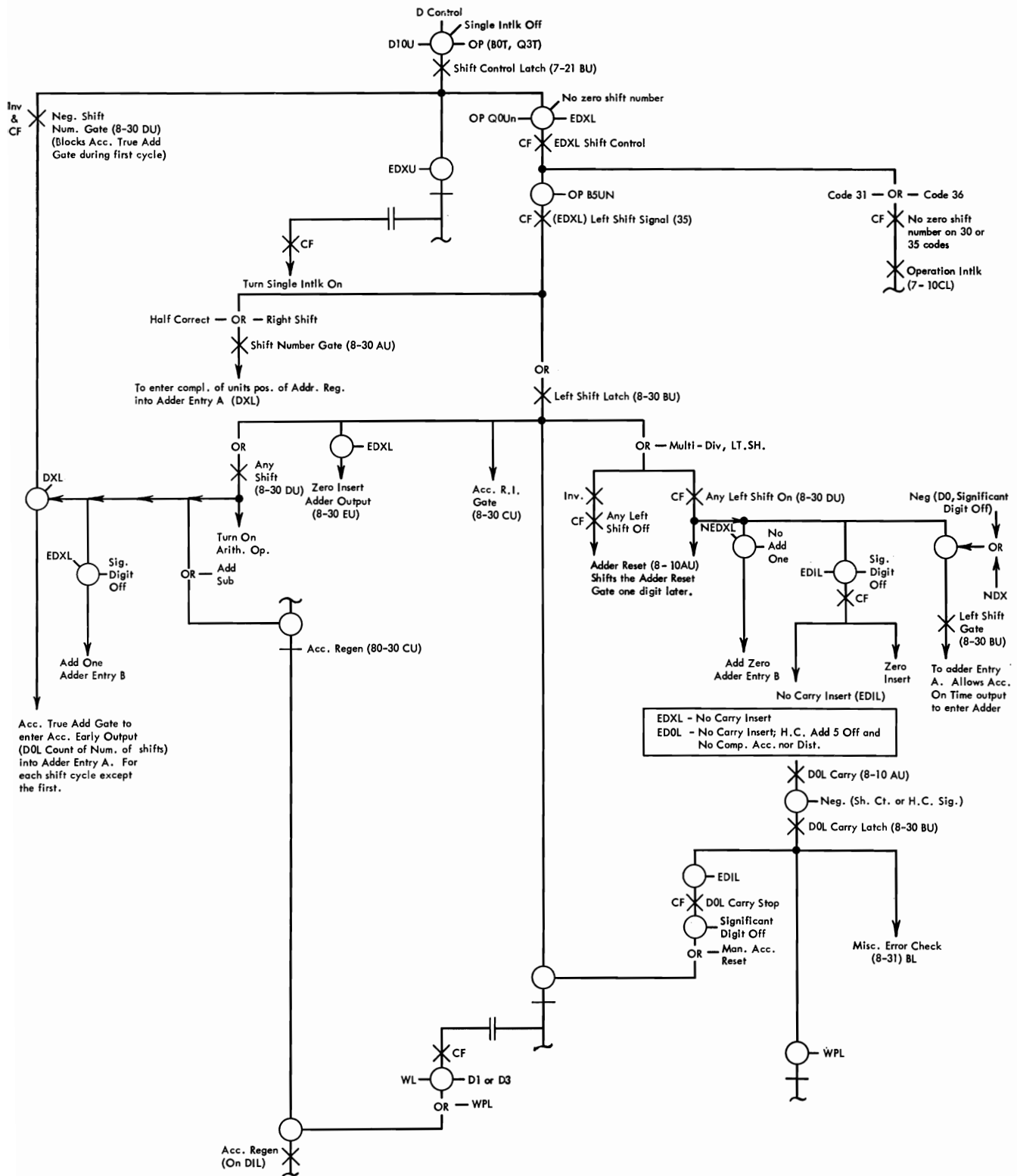

Figure V-27. Shift Left: Function Chart—Code 35

A data address with a units of zero will result in a right shift of ten with rounding. A carry from D0L will occur on the first shift cycle when the shift number is zero. Code 31 develops a negative half-correct signal to block this carry-stop.

On the last shift cycle the contents of the accumulator D1L position enters the D0L position via the right shift path. The shift count number, coming from the adder output, is blocked. This is accomplished by the half-correct-add-five latch turning on at D0L, and blocking the accumulator read-in gate.

Removal of the OFF output of the half-correct-add-five latch also prevents the no-carry insert at D0L time of the half-correct cycle. This allows the carry or no-carry status of the adder latches to be determined by the result of the half correction.

### Code 35 SLT (Shift Left) (Figures V-26 and V-27)

#### Objective:

The contents of the accumulator are shifted to the left the number of places specified by the units digit of the D-address.

On a left shift operation the accumulator *on-time* output enters the adder. It is merged with zeros from the B input and is available from the adder output one digit time later, to be stored in the accumulator one digit position to the left of its original location. In this case the D10L position of the accumulator is read out at D9L time but held in the early latches during D9L time and is presented to the adder from the on-time latches during D10L time.

For proper left shift operation, the D10L information must be available from the adder output at D1U time, for storage in the D1U position of the accumulator. The D10L information cannot be held in the *on-time* latches because they are reset at DXaU time. Therefore, the D10L information must be transferred to the adder latches by normal adder action at DXaU time and held there through D1U time.

The status of the adder latches must not be allowed to change until after D1U time, when their information is read into the accumulator. The D1U position is read-out to the early latches at D10L time as usual and stored there until transferred to

the on-time latches when the early latches are allowed to reset at D1aU time. This D1U information is presented to the adder from the on-time latches during D1U time and the carry or no-carry indication from D10L must still be available at this time for proper analysis of the D1U information. This carry no-carry indication will still be available in the carry no-carry latches if they are not allowed to change until after D1U time.

To accomplish this, no new information must be presented to the adder latches during DXU and D0U time and none of the adder latches must be reset at D0aU or D1aU times.

The left shift gate is closed at DX and D0 time, insuring that no new information will enter the A input during these times, thus blocking any new input to the adder latches. The adder reset control latch is controlled to block latch resets at D0aU and D1aU times.

### Code 36 SCT (Shift and Count) (Figures V-28, V-29, and V-29A, B)

#### Objectives:

1. The contents of the accumulator are shifted to the left until,
  - a. A no-zero is sensed in the D10U position, or
  - b. A D0L carry is sensed (except on the first cycle).
2. Enter the number of shifts in the D1L and D2L positions of the accumulator.

A left shift and count operation is accomplished much the same as left shift except that the appearance of a significant digit in the accumulator D10U position is detected to stop the operation. The shift number in the address register units position is usually zero; so the shift count number in the accumulator D0L position indicates the number of shifts used before a significant digit is sensed in D10U. If a D0L carry is detected before a significant digit appears in D10U, it is an indication that the maximum allowable number of shifts has been taken. The overflow circuits will be set up, and a shift count of 10 will remain in the accumulator D2L and D1L positions.

When a shift number of zero accompanies this operation, the maximum allowable number of shifts



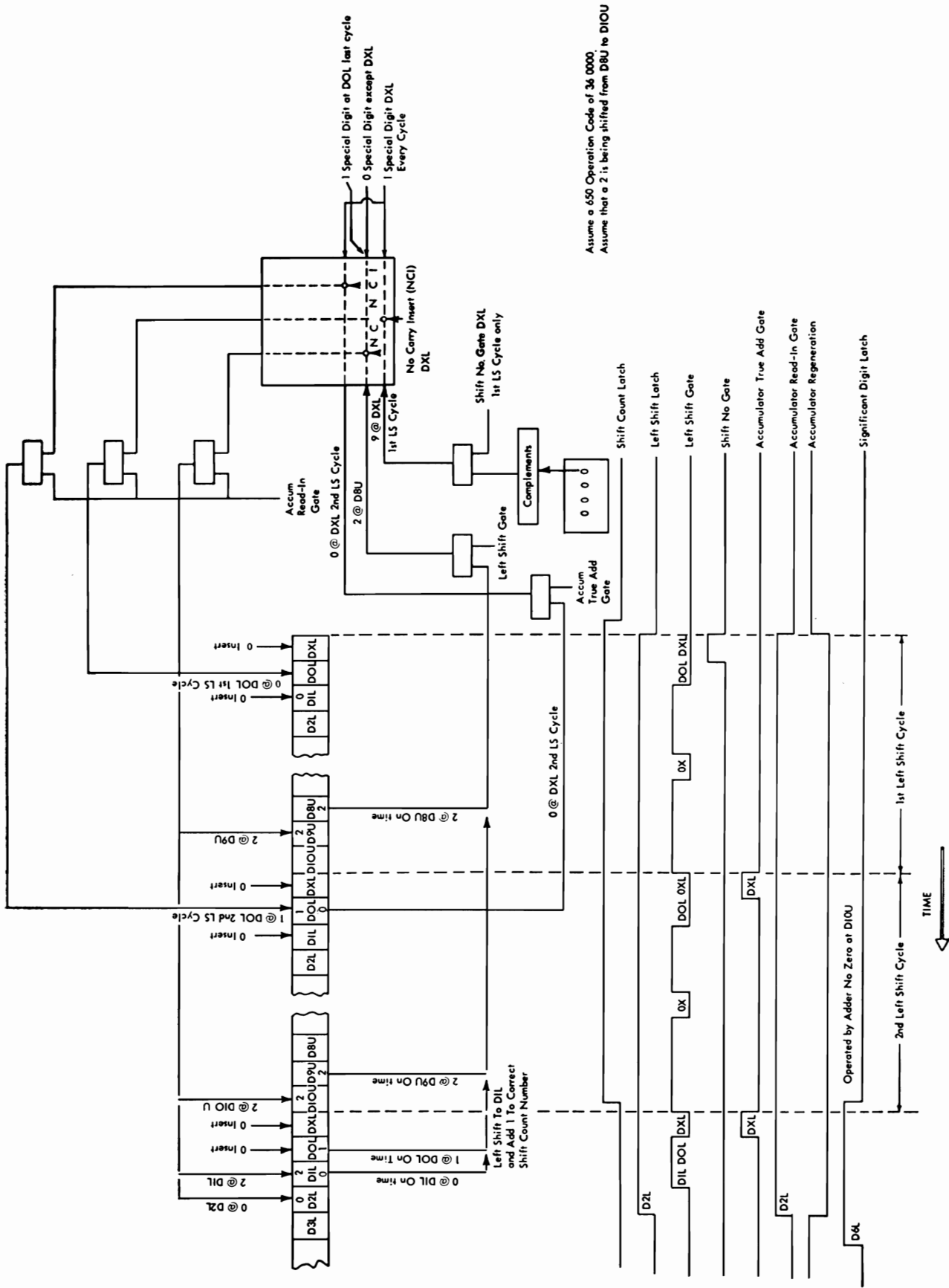

Figure V-28. Shift Left and Count: Block Diagram—Code 36

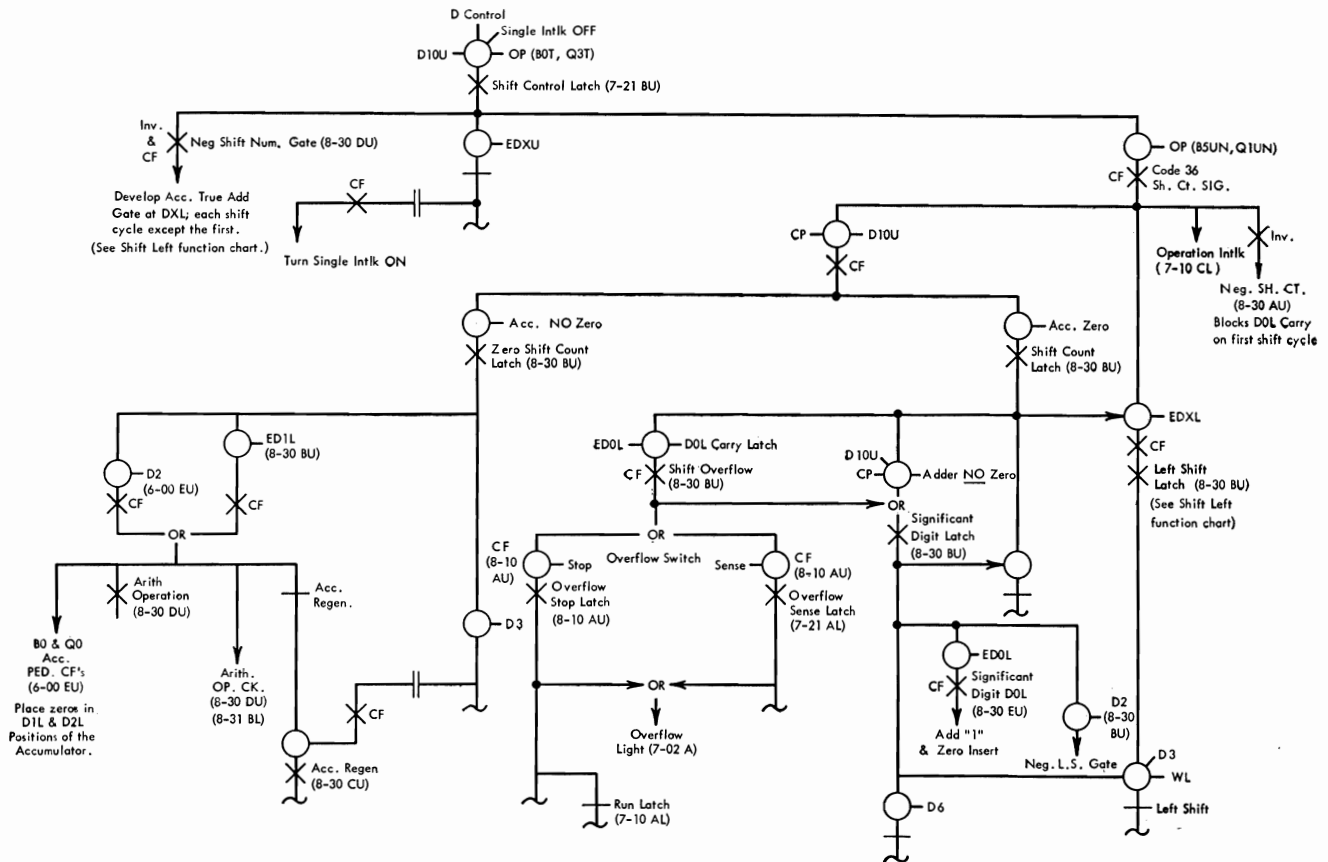

Figure V-29. Shift Left and Count: Function Chart—Code 36

is ten. If it is desired, for any reason, to limit the number of allowable shifts to fewer than ten, the number of allowable shifts desired can be indicated by the value of the units position of the *D*-address. In this way the number of shifts needed to cause a D0L carry is reduced. If, in this case, a significant digit is sensed before a D0L carry occurs, the shift count number in the D1L and D2L accumulator positions is the ten's complement of the unused allowable shifts.

## BRANCH OPERATIONS (40's and 90's Codes) Code 44 (Figure V-30)

### BRNZU Branch on Non-Zero in Upper Half of Accumulator (44)

The contents of the upper half of the accumulator are examined. If it is zero, the next instruction is taken from the location specified by the *I*-address. If it is not zero, the next instruction is taken from the location specified by the *D*-address.

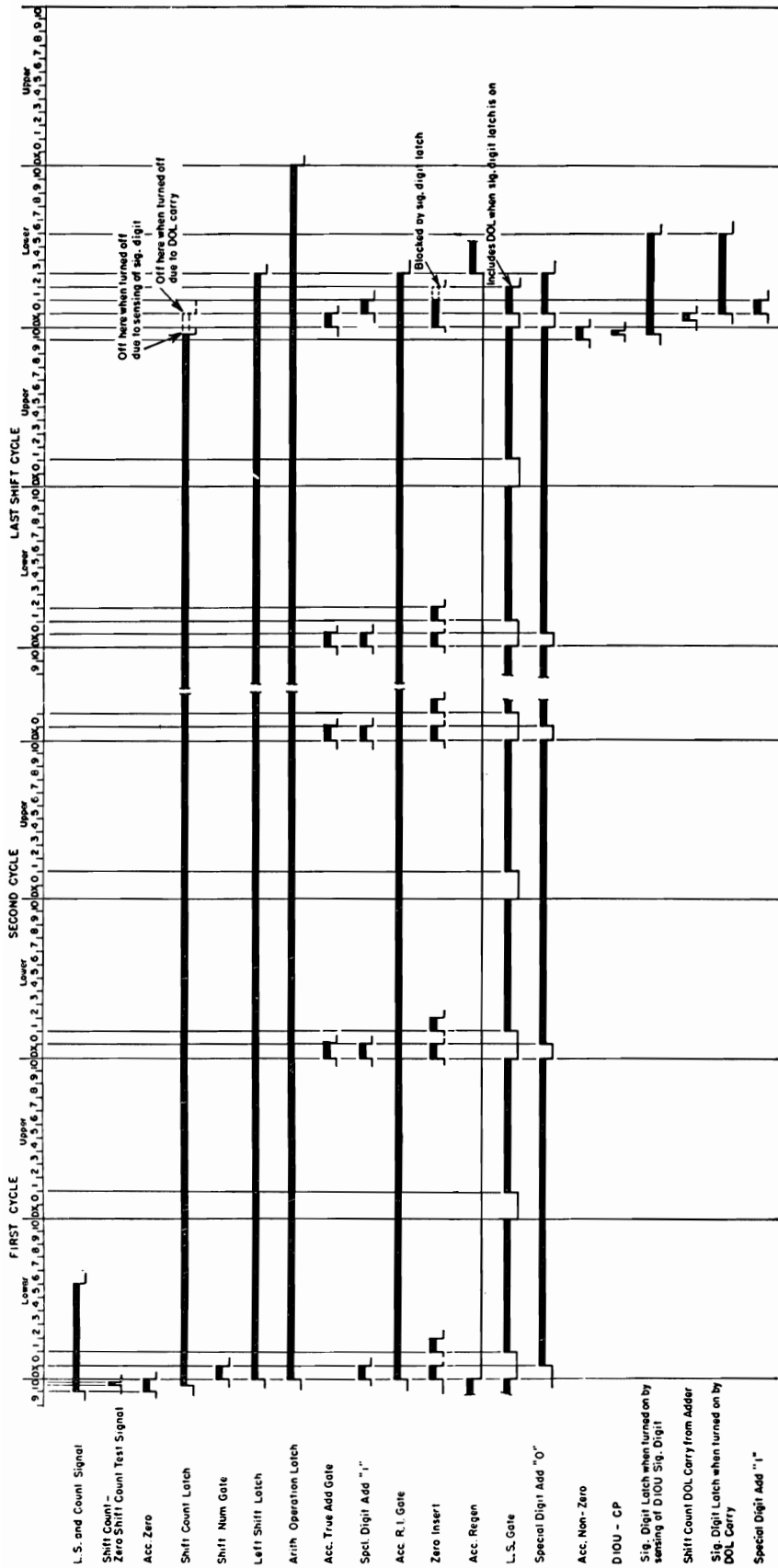

Figure V-29A. Shift Left and Count: Timing Chart, with Left Shift Cycles

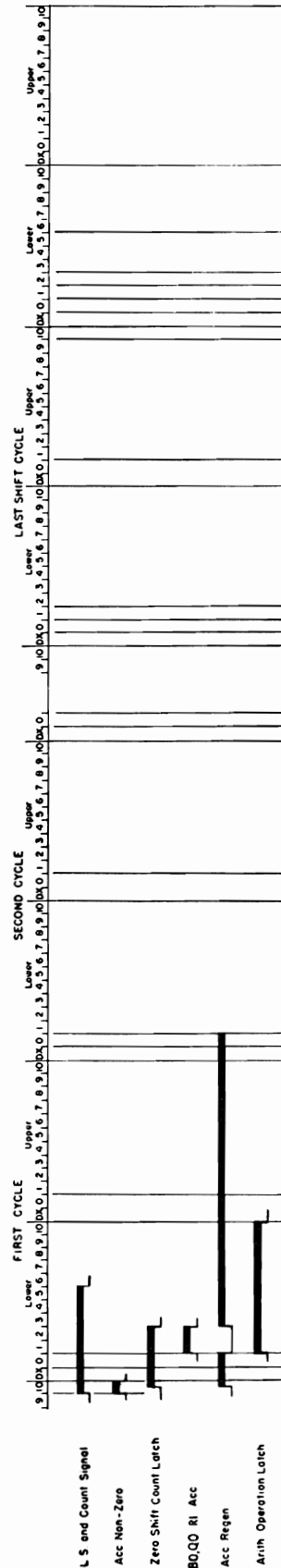

Figure V-29B. Shift Left and Count: Timing Chart, with No Left Shift Cycles

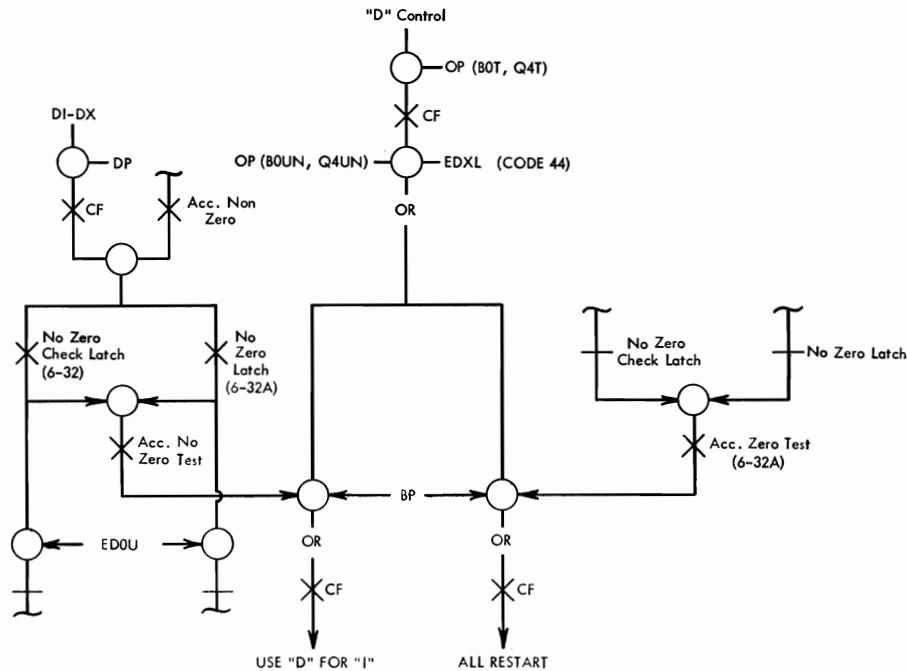

Figure V-30. Branch Non-Zero Upper—Code 44

Code 45 (Figure V-31, page V-34)

BRNZ Branch on Non-Zero in Accumulator (45)

The contents of the entire accumulator are examined. If it is zero, the next instruction is taken from the location specified by the I-address. If it is not zero, the next instruction is taken from the location specified by the D-address.

Description (Codes 44 and 45)

Codes 44 and 45 test the output of two latches shown in WD 6-32. Note that both latches do the same thing. If the no-zero latch and no-zero check-latch are both on, an accumulator no-zero test output appears at terminal Aa. If the no-zero latch and no-zero check-latch are both off, then an accumulator zero test output appears on terminal Ab. Both latches are turned off at D0U time.

Figure V-32 shows how a number like 0000500000 in the upper accumulator can turn on the no-zero latches in WD6-32 at D6 upper time. Because the latches are reset at D0U time, a test can be made at DXL time to determine whether the upper accumulator is non-zero. Similarly, at DXU time a test can be made to determine whether the entire accumulator is non-zero. At DXU time, each position of the accumulator has had a chance to turn the latches on.

In the case of both 44 and 45 codes, if the test finds the accumulator non-zero, branching must take place and a Use-D-for-I signal must be developed. The result of a Use-D-for-I signal is that no restart and resulting reset of the address register takes place. Therefore, the D-address associated with the operation code of 44 or 45 is used as the location of the next instruction. If the test finds the accumulator zero, a restart signal is developed, the address register is reset, and during the next restart B time, the I-address of the 44 or 45 instruction words enters the address register. The next instruction is then found in the I-address and branching fails to take place.

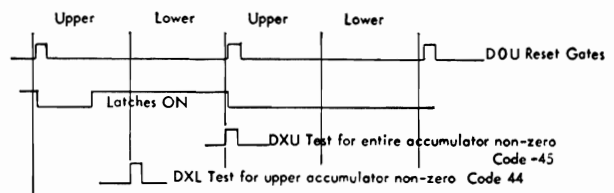

Figure V-32. Branch Codes 44 and 45 Timing Chart

CONTROL COMMUTATOR OPERATION: 45 Code BRNZ

Assume that the 650 is operating with the following series of program steps:

xx xxxx 0003  
45 0006 0008

Assume the Accumulator is Zero

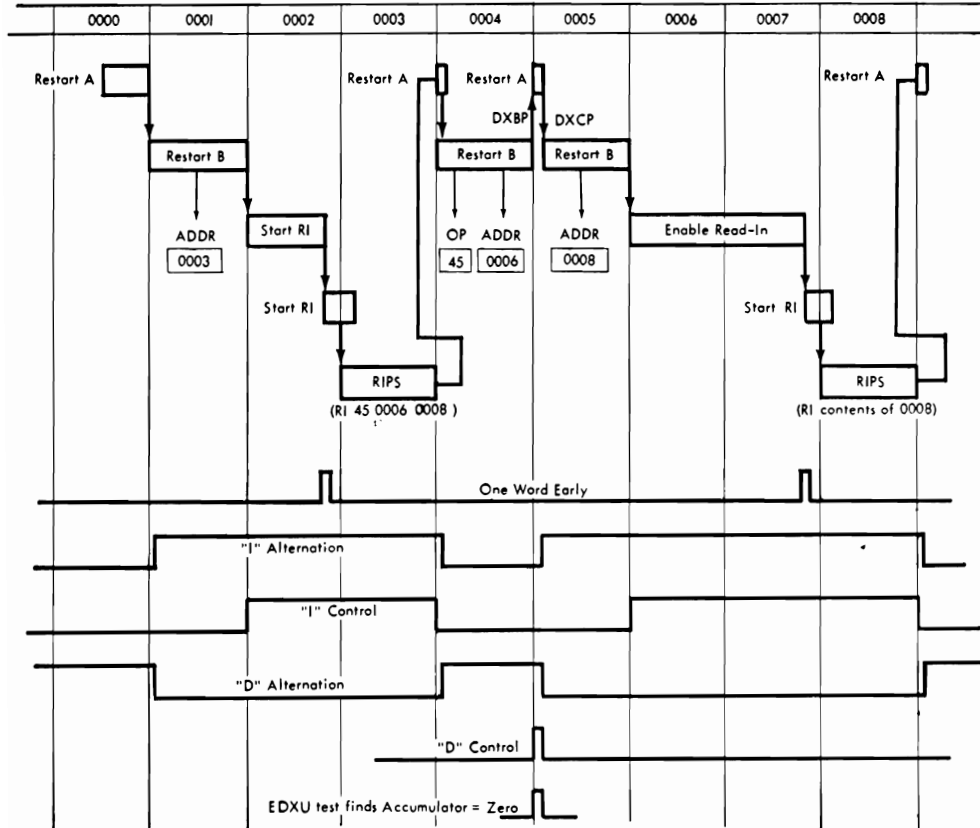

Assume the Accumulator is non-zero

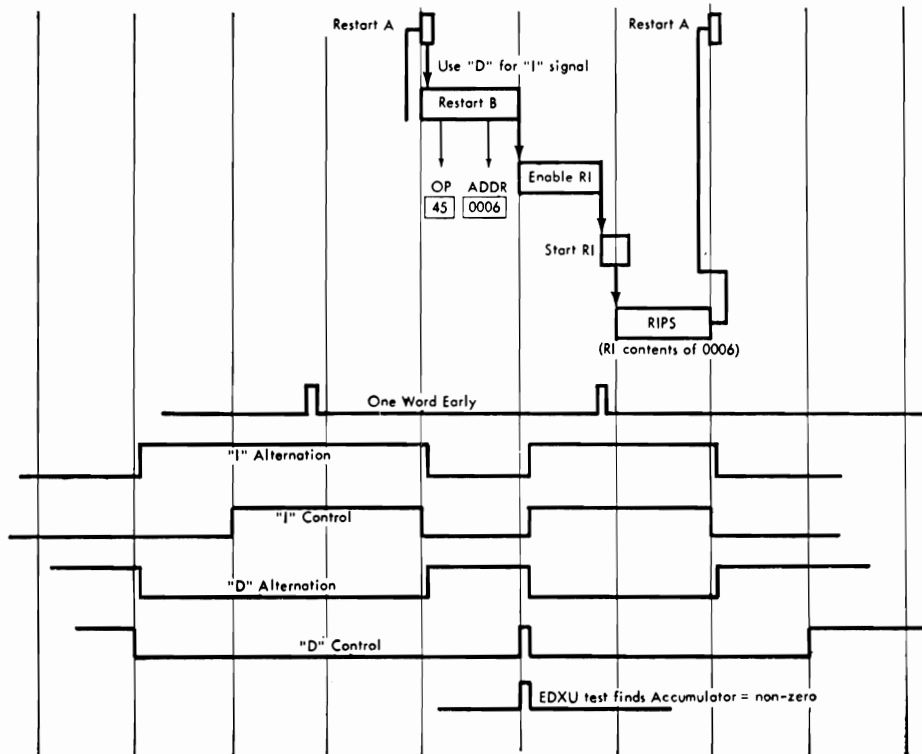

Figure V-31. Control Commutator Operation—Code 45

**Code 46**

BR MIN (46)

The sign of the accumulator is examined. If it is positive, the next instruction is taken from the location specified by the I-address. If it is negative, the next instruction is taken from the location specified by the D-address.

**Description—Code 46**

Code 46 tests whether the accumulator plus sign or accumulator minus sign latch is on. These latches were set up when the last accumulator entry was made. No waiting for a special test time is required and the test is timed by the appearance of D control. If the plus latch is on, a restart is developed. If the minus latch is on, a use-D-for-I signal is developed.

**Circuits for Code 46**

1. On WD7-21AL, the D control 46 code signal is switched with the output of the accumulator plus latch to give a restart signal.
2. The D control 46 code signal is switched with the output of the accumulator minus latch to give a Use-D-for-I signal.

**Code 47 (Figure V-33)**

**Objective**

Examine the condition of the overflow circuit. If it is not set (indicating that no overflow has occurred), the next instruction is taken from the location specified by the I-address. If it is set (indicating that an overflow has occurred), the next instruction is taken from the location specified by the D-address.

**Description Code 47 (WD 7-10, WD 7-21)**

Code 47 tests for an accumulator overflow condition as indicated by the status of the overflow sense latch (WD7-21AL). If this latch is off, a restart is signaled. If it is on, the next D1 turns it off and a capacitor-coupled cathode follower pulse when it goes off is the use-D-for-I signal.

**Test Codes (90's) (Figure V-34)**

**Objectives**

The 90's codes test the digit positions of the distributor for eight's. For example, if a 93 code is programmed, a test is made of the D3 position of the

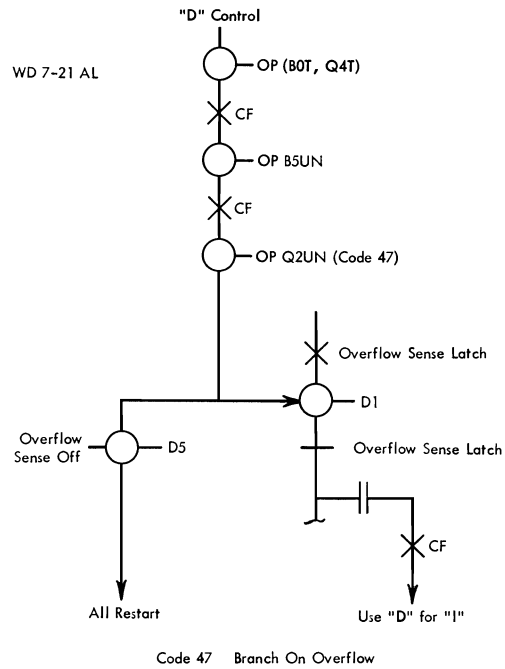

Figure V-33. Branch on Overflow—Code 47

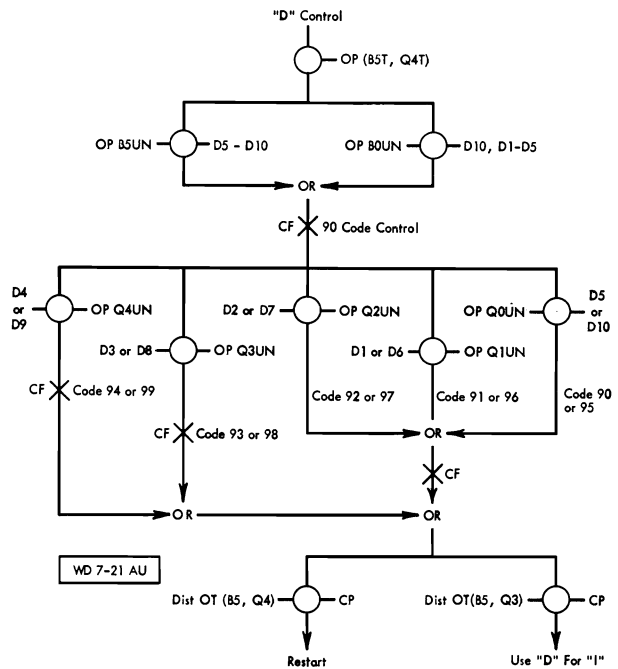

Figure V-34. Branch on "8" in Position 1-10—Code 90's

distributor to determine whether it contains an 8 or a 9. If the third position contains a digit 9, the next instruction is taken from the location specified by the I-address. If the third position contains a digit 8, the next instruction is taken from the location specified by the D-address. If the third position contains a digit other than an 8 or 9, it is an error and the calculator will stop.

#### Description Code 90-99

During the word interval following the appearance of D control, the operation code value is switched with digit timing pulses to produce a test gate. The digit interval during which the test gate is developed depends on the value of the operation code such that

code 90 produces a D10  
 code 91 produces a D1  
 code 92 produces a D2  
 code 93 produces a D3  
 code 94 produces a D4  
 code 95 produces a D5  
 code 96 produces a D6  
 code 97 produces a D7  
 code 98 produces a D8  
 code 99 produces a D9

This test gate is then separately switched with the distributor B5-Q3 on-time outputs and the B5-Q4 on-time outputs to develop either a *use-D-for-I* signal if the distributor contains an 8, or a restart signal if the distributor contains a 9.

### MULTIPLICATION (Code 19) (Figures V-35 to V-41)

THE contents of the location specified by the D-address are multiplied by the contents of the upper half of the accumulator. The twenty-digit product is developed in the accumulator, and the multiplier is lost.

On a code 19 it is possible to process a maximum of a ten-digit multiplier with a ten-digit multiplicand to develop a twenty-digit product. The multiplication operation is a combination of left shift and true add cycles.

#### Functions, Objectives and Circuits (Code 19)

##### Description

1. The multiplier is in the upper accumulator as the result of a previous operation.

2. The multiplicand is put in the distributor from storage (part of the multiply operation).

3. The entire accumulator except the DXL and D0L positions is shifted left one place. During this shift, the high-order position of the accumulator, which is the multiplier digit, is shifted into the DXL position of the accumulator. The multiplicand is added into the lower accumulator the number of times indicated by this multiplier digit. If the multiplier digit is a zero another left shift is signaled.

4. Step 3 is repeated ten times, once for each multiplier digit. A count of these shifts will be kept in the D0L position to set up end-of-multiply.

5. The twenty-digit product is given the proper sign according to the signs of the factors.

The lower accumulator must be clear for this operation. If the lower accumulator contains some number at the start of a multiplication, the final result will have the absolute value of that number added to the ten high-order positions of the absolute value of the product and this result will be given the sign of the product. Thus, much care must be taken to assure that the lower accumulator is clear before a multiplication. Figure V-35 shows the values in the accumulator during the cycles of a typical multiply operation.

#### General Circuit Action Code 19

The first cycle of a multiply operation is a *multiply-divide left shift* cycle which is controlled by the multiply latch and the multiply-divide left shift latch, resulting in shifting the multiplier one position to the left in the accumulator. This places the high-order digit in the DXL position. Any partial product that may be in the lower accumulator is, of course, also shifted left one position, because any shift involves the whole accumulator. Also, on a multiply-divide left shift cycle, the shift count number in the accumulator D0L position is advanced by one. This number is zero at the start of the operation, so it becomes one during the first part of the first multiply add cycle.

At DXL time of each multiply cycle the adder output is tested for zero or non-zero. When this test is made at DXL of the cycle following a multiply-divide

TYPICAL MULTIPLY OPERATION

10 Digit Multiplicand  
10 Digit Multiplier  
20 Digit Product

3179848209  
5213874169

16579328438246013321

ACC. CYCLE	Multiplier	Left Shift	10	9	8	7	6	5	4	3	2	1	0	X	10	9	8	7	6	5	4	3	2	1	0	X	Shift count	Add count		
1			5	2	1	3	8	7	4	1	6	9			0	0	0	0	0	0	0	0	0	0						
2			2	1	3	8	7	4	1	6	9	0			0	0	0	0	0	0	0	0	1	0						
3			2	1	3	8	7	4	1	6	9	0			3	1	7	9	8	4	8	2	0	9	1	5				
4			2	1	3	8	7	4	1	6	9	0			6	3	5	9	6	9	6	4	1	8	1	4				
5			2	1	3	8	7	4	1	6	9	0			9	5	3	9	5	4	4	6	2	7	1	3				
6			2	1	3	8	7	4	1	6	9	0			2	7	1	9	3	9	2	8	3	6	1	2				
7			2	1	3	8	7	4	1	6	9	1			5	8	9	9	2	4	1	0	4	5	1	1				
8			2	1	3	8	7	4	1	6	9	1	5		8	9	9	2	4	1	0	4	5	2	0					
9			1	3	8	7	4	1	6	9	1	6			2	1	7	2	5	8	6	5	9	2	2					
10			1	3	8	7	4	1	6	9	1	6			5	3	5	2	1	0	6	8	6	8	2					
11			3	8	7	4	1	6	9	1	6	5			3	5	2	1	0	6	8	6	8	0	3					
12			3	8	7	4	1	6	9	1	6	5			6	7	0	0	9	1	6	8	8	9	3					
13			8	7	4	1	6	9	1	6	5	6			7	0	0	9	1	6	8	8	9	0	4					
14			8	7	4	1	6	9	1	6	5	7			0	1	8	9	0	1	7	0	9	9	4	3				
15			8	7	4	1	6	9	1	6	5	7			3	3	6	8	6	5	3	0	8	4	2					
16			8	7	4	1	6	9	1	6	5	7			6	5	4	8	7	1	3	5	1	7	4	1				
17			7	4	1	6	9	1	6	5	7	6			5	4	8	7	1	3	5	1	7	0	5	0				
18			7	4	1	6	9	1	6	5	7	6			8	6	6	9	8	3	7	9	5	8						
19			7	4	1	6	9	1	6	5	7	6			1	8	4	6	8	3	1	5	8	8	5	7				
20			7	4	1	6	9	1	6	5	7	7			5	0	2	6	6	7	9	7	9	7	5	6				
21			7	4	1	6	9	1	6	5	7	7			8	2	0	6	5	2	8	0	6	5	5					
22			7	4	1	6	9	1	6	5	7	8			1	3	8	6	3	7	6	2	1	5	4	5				
23			7	4	1	6	9	1	6	5	7	8			4	5	6	2	2	4	4	2	4	5	3					
24			7	4	1	6	9	1	6	5	7	8			7	7	4	6	0	7	2	6	3	5	2					
25			7	4	1	6	9	1	6	5	7	9			0	9	2	5	9	2	0	8	4	2	5	1				
26			4	1	6	9	1	6	5	7	9	0			9	2	5	9	2	0	8	4	2	6	0					
27			4	1	6	9	1	6	5	7	9	1			2	4	3	9	0	5	6	6	2	9	6	7				
28			4	1	6	9	1	6	5	7	9	1			5	6	1	8	9	0	4	8	3	8	6	6				
29			4	1	6	9	1	6	5	7	9	1			8	7	9	8	7	5	3	0	4	7	6	5				
30			4	1	6	9	1	6	5	7	9	2			1	9	7	8	6	0	1	2	5	6	6	4				

ACC. CYCLE	10	9	8	7	6	5	4	3	2	1	0	X	10	9	8	7	6	5	4	3	2	1	0	X	Shift count	Add count					
31														4	1	6	9	1	6	5	7	9	2								
32														4	1	6	9	1	6	5	7	9	2								
33														4	1	6	9	1	6	5	7	9	3								
34														L S																	
35														Add																	
36														Add																	
37														Add																	
38														Add																	
39														L S																	
40														Add																	
41														L S																	
42														Add																	
43														Add																	
44														Add																	
45														Add																	
46														Add																	
47														Add																	
48														L S																	
49														Add																	
50														Add																	
51														Add																	
52														Add																	
53														Add																	
54														Add																	
55														Add																	
56														Add																	
57														Add																	
58														Stop																	

Figure V-35. Accumulator Values during Typical Multiplication



left shift cycle and a non-zero condition is detected, the accumulator true add latch, the lower control latch, and the distributor true add latch are turned on. If a zero is detected, the multiply-divide left shift latch is held on for another multiply-divide left shift cycle. If the accumulator true add, lower control and distributor true add latches are turned on, gates are developed that allow the distributor contents to be added to the lower accumulator on a true add cycle, just as in add and subtract operations. On a true add cycle, during multiplication a nine is added to the multiplier high-order digit (in the DXL position) as it is processed by the adder at D10U time. This effectively reduces its value by one. The reduced multiplier digit is stored back in the DXL position. As this reduced multiplier digit comes from the adder at DXL time, its zero or non-zero condition is tested. Non-zero holds the accumulator true add, lower control and distributor true add latches on for another add cycle. Zero allows them to turn off, but turns multiply-divide left shift back on for another multiply-divide left shift cycle, to shift the multiplier and partial product one position to the left and advance the shift count number.

This shifting and adding continues until a D0L carry is detected as the shift count is advanced to ten on the last 10th multiply-divide left shift cycle. This D0L carry turns on the end multiply-divide latch. Another series of add cycles occurs until DXL is reduced to zero. This adder DXL zero, the first to be detected after the end multiply-divide latch is turned on, turns off the multiply latch to end the operation instead of turning on the multiply-divide left shift latch.

The sign of the product, developed by analyzing the sign of the accumulator (multiplier) and the sign of the distributor (multiplicand) is placed in the accumulator sign latches during the first part of the first multiply-divide left shift cycle. It is entered under control of the multiply signal, which occurs once at the beginning of the operation.

#### Multiplication Consists of

1. Sign analysis
  2. Multiply left shift cycles
  3. Multiply true add cycles
- (Figure V-36)

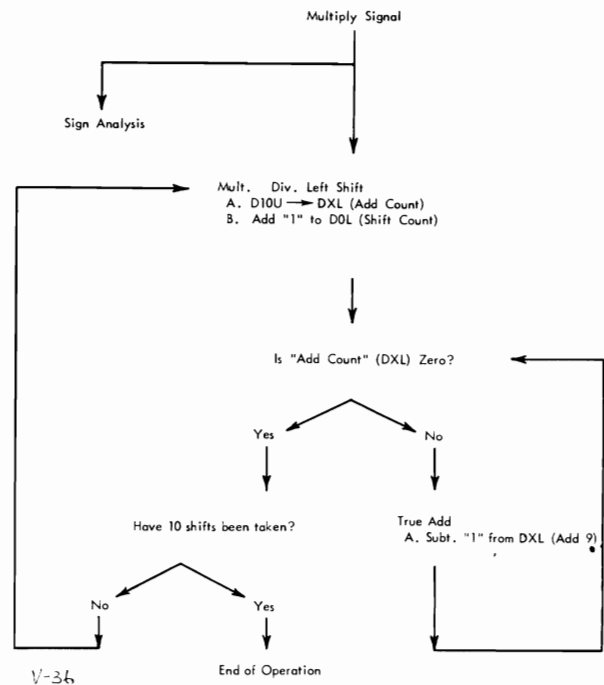

Figure V-36. Multiplication—Code 19

#### Major Objective:

Multiply specified D-address contents, by upper accumulator contents.

NOTE: the multiplier is in the upper accumulator as the result of a previous operation.

#### Minor Objectives:

1. Read specified D-address contents into the distributor (Figure V-4)
  - a. (10's & 60's — D Control No. 8001) (7-10CU)
  - b. Enable, start read-in sequence
2. Multiply setup (Figure V-37)
  - a. Multiply latch
  - b. Sign analysis
    - (1) Reset remainder sign latches.
    - (2) Transfer accumulator sign to the remainder sign latches.
    - (3) Reset accumulator sign latches.
    - (4) Set accumulator sign latches with the sign of the product.

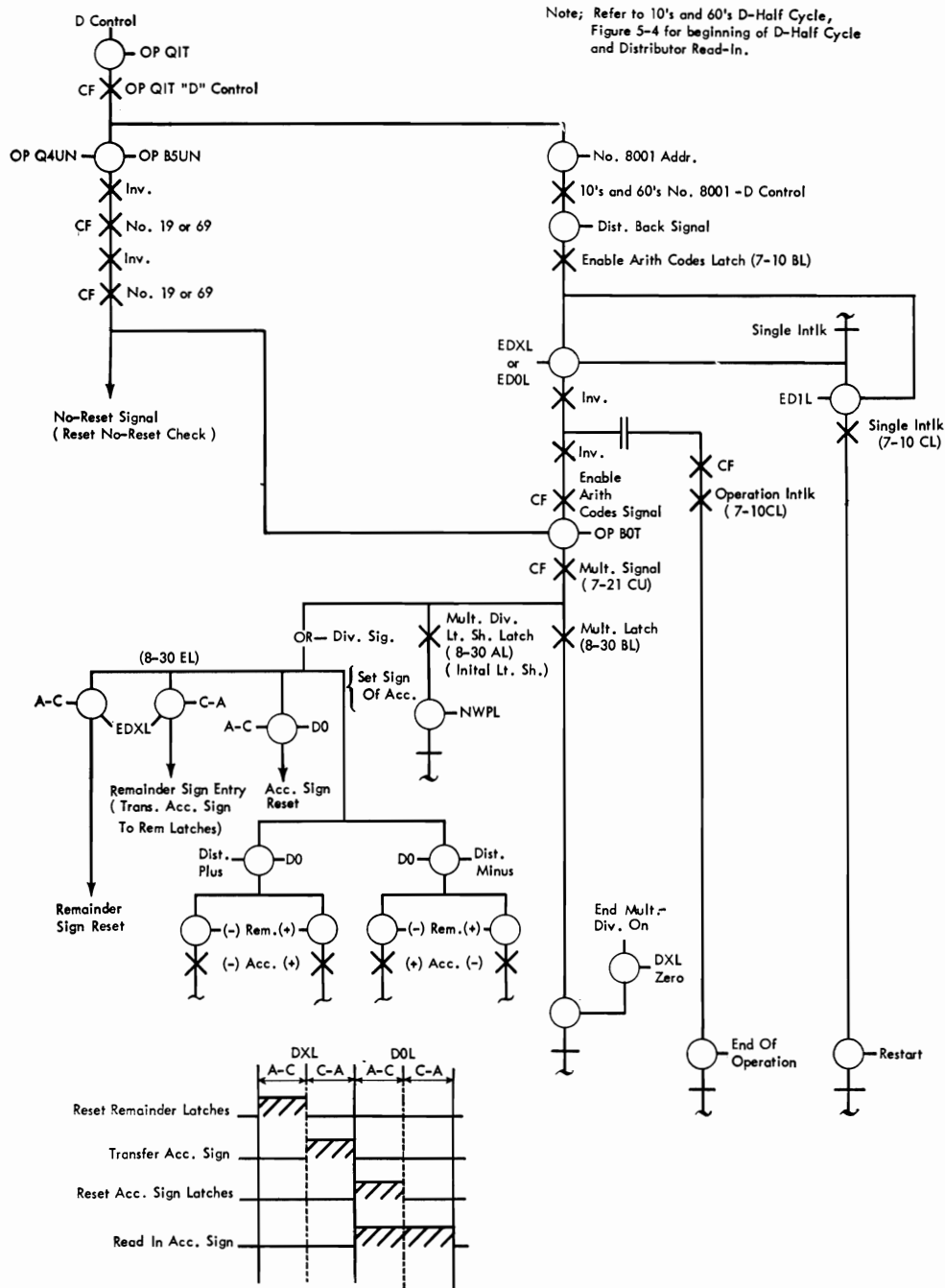

Figure V-37. Multiply Setup

3. Multiply left shift (Figure V-38)

a. Multiply signal initiates the first left shift cycle.

(1) Zero insert at DXL to satisfy validity at DXL time of the next cycle.

(a) No adder output at DXL time, of the first left shift cycle.

(2) Arithmetic restart.

b. Zero add count initiates remaining left shift cycles.

(1) Adder output B0 and Q0 at DXL.

(2) End-multiply-divide latch off.

c. Transfer D10U contents to DXL (add count)

d. Add one to the shift count number (D0L)

4. Multiply true add (Figure V-39)

a. Add count non-zero.

(1) Adder output non-zero at DXL time.

b. Decrease add count by one.

(1) Special digit add nine at D10U.

(2) No-carry insert and carry blank at DXL.

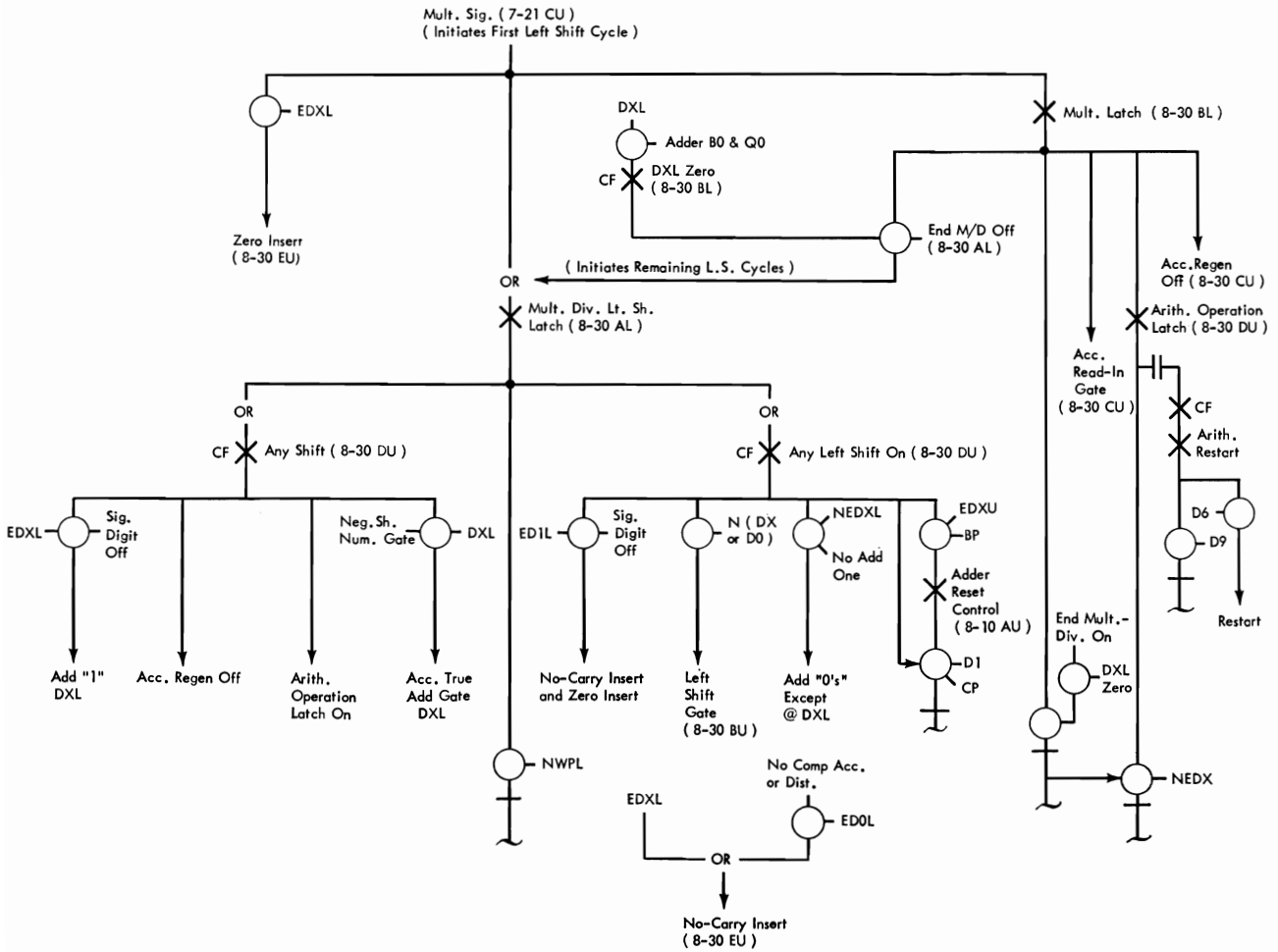
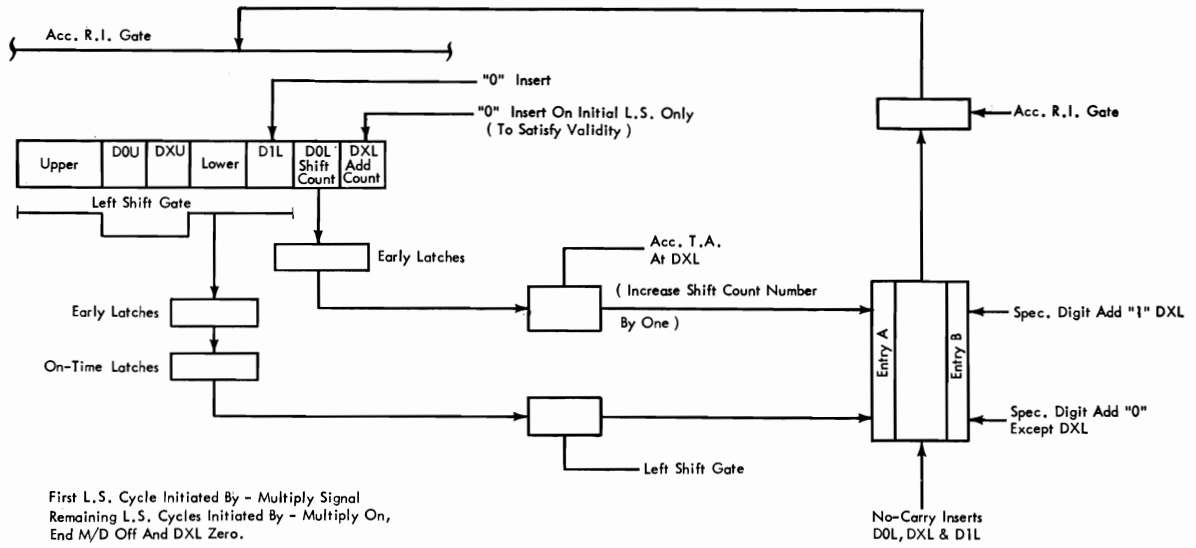

Figure V-38. Multiply Left Shift Cycle

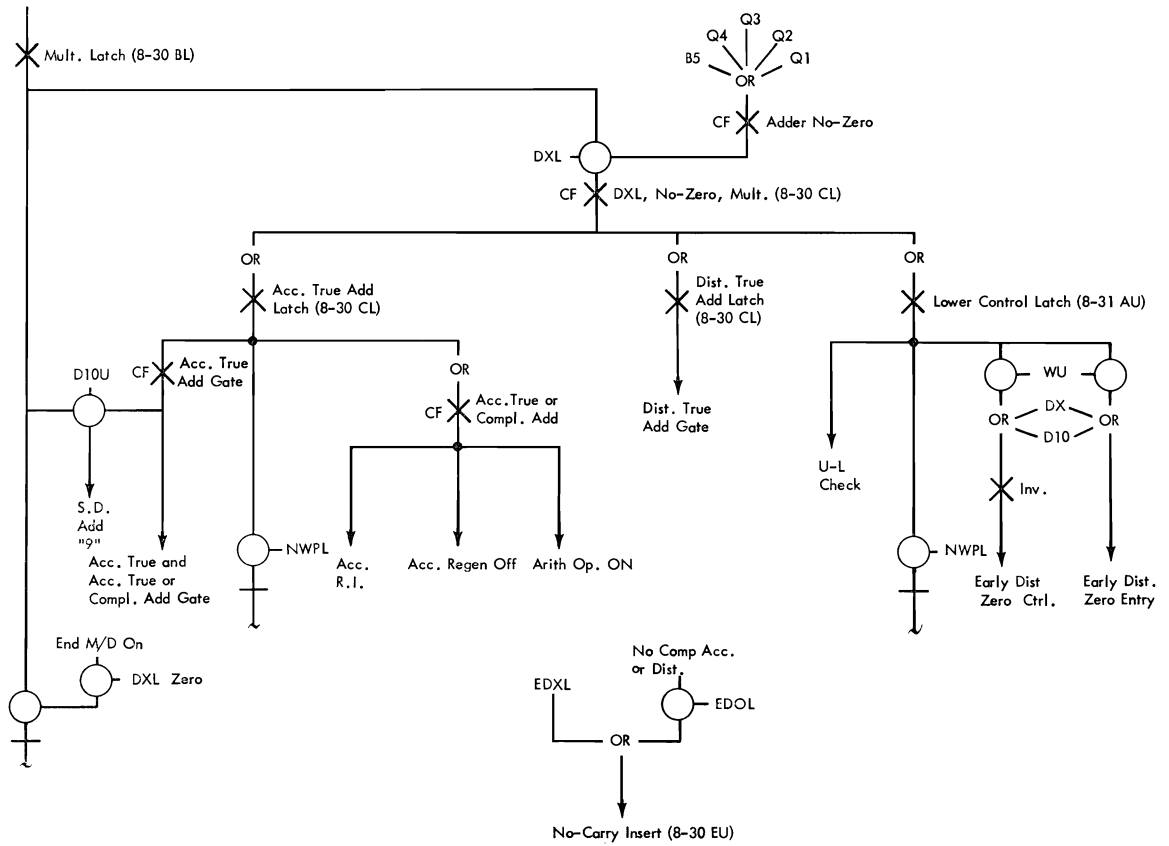
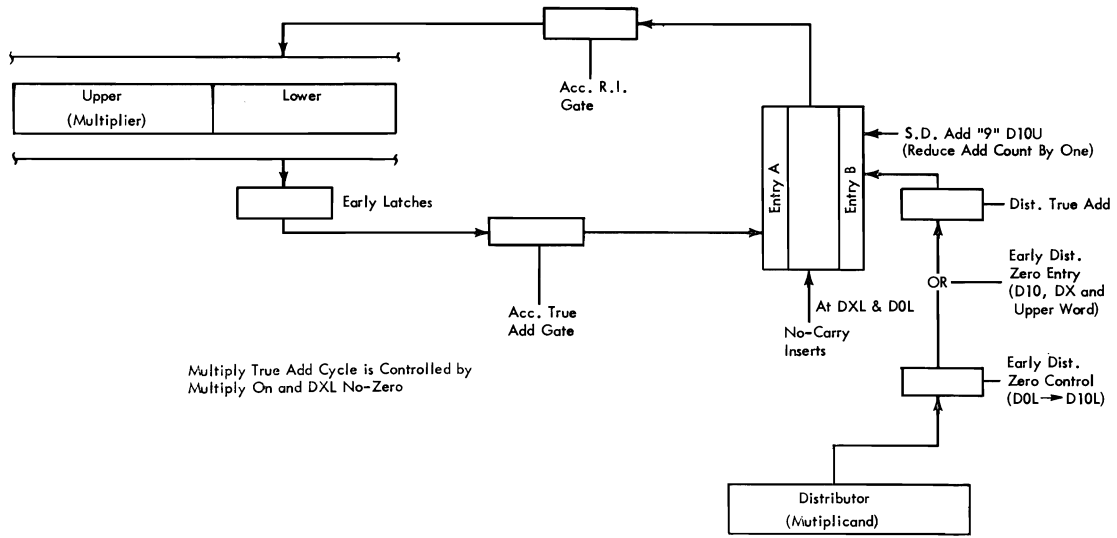

Figure V-39. Multiply True Add Cycle

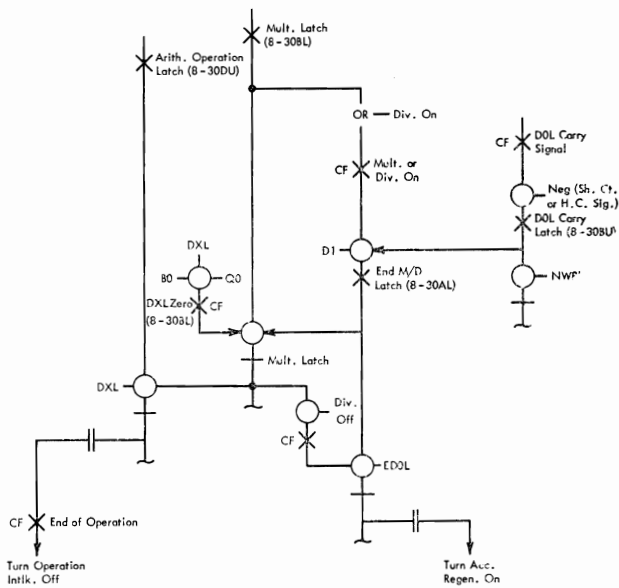

Figure V-40. End of Multiply

5. Allow control commutator to advance (Figure V-40).

a. Turn operation interlock off.

(1) End-of-operation.

Refer to Figure V-41 for multiply sequence chart, pages V-44 and V-45.

### DIVISION (Code 14) (Figures V-42 to V-52)

THE dividend must be in the accumulator as the result of a previous operation. The divisor is placed in the distributor from the D-address location specified in the divide instruction. The quotient will be developed in the lower accumulator and its sign will be in the accumulator sign latches. The remainder will be in the upper accumulator and its sign will be in the remainder sign latches. Either half of the accumulator with its corresponding sign may be stored.

#### Principles of Division

Division is accomplished by taking a left shift cycle on the first cycle of divide, then subtracting the divisor (distributor) from the upper accumulator until a dividend sign change indicates it has been subtracted one too many times. Each time the divisor is subtracted with no change in dividend sign, a one is

added to the quotient (D1 Lower Acc.). When a dividend sign change occurs, the divisor is added once to the upper accumulator to correct for the overdraw. The reduced dividend and partial quotient are then shifted one place to the left. The divisor is subtracted from the reduced dividend until a dividend sign change occurs. Each time the divisor is subtracted with no change in dividend sign, a one is added to the quotient (D1 Lower Acc.).

This process is repeated for ten shifts in all. On the tenth left shift a D0L carry turns on the end-multiply-divide latch. The divisor is subtracted as before from the dividend until a dividend sign change occurs. A one is added to the quotient for each cycle the divisor is subtracted with no change in dividend sign. The divisor is added once to the dividend to correct for the overdraw and signals for a left shift. This time, however, because the end-multiply-divide latch is on, instead of left shifting we end division (turn divide latch off).

Figure V-42 illustrates the concept of division, using an abbreviated accumulator with eight positions for simplicity. The problem  $1440 \div 12 = 120$  is used. The first cycle of a divide operation is a multiply-divide left shift cycle. This clears the D1L accumulator position for possible quotient digit entries during the first shift. In the case of the eight-position accumulator shown, only four shifts are possible. In actual practice the 650, with its 20-digit accumulator, uses ten shifts for each division. The number of shifts is counted, as in other shifting operations, and the count retained in the accumulator D0L position. This shift count action is not shown in the chart.

On any division the number of digits in the quotient is determined by the number of digits in the dividend and divisor. In the 650 the maximum number of quotient digits that can be developed is ten and is governed by the capacity of the accumulator and distributor. Thus, on any 650 divide operation, the highest significant dividend digit must be positioned in the accumulator, taking into account the number of digits in the divisor, so that no more than nine subtractions will be required on the first shift to produce a sign change.

When the dividend is not properly positioned and more than nine subtractions would be needed to cause a sign change, more than nine quotient digit one

PROBLEM:  
1440 ÷ 12 = 120

	ACCUMULATOR								
	UPPER				LOWER				
	D4	D3	D2	D1	D4	D3	D2	D1	D0L
Dividend	0	0	0	0	1	4	4	0	0
Shift	0	0	0	1	4	4	0	0	1
Subtract Div. (Upper)	-0	0	1	2	0	0	0	0	1
Sign Change	9	9	8	9	4	4	0	0	1
Correct	+0	0	1	2	0	0	0	0	1
	0	0	0	1	4	4	0	0	1
Shift	0	0	1	4	4	0	0	0	2
Subtract Div. (Upper)	-0	0	1	2	0	0	0	0	2
No Sign Change	0	0	0	2	4	0	0	0	2
Subtr. Div. (Upper) Enter "1" (Lwr.)	-0	0	1	2	0	0	0	1	2
Sign Change	9	9	9	0	4	0	0	1	2
Correct	+0	0	1	2	0	0	0	0	2
	0	0	0	2	4	0	0	1	2
Shift	0	0	2	4	0	0	1	0	3
Subtr. Div. (Upper)	-0	0	1	2	0	0	0	0	3
No Sign Change	0	0	1	2	0	0	1	0	3
Subtr. Div. (Upper) Enter "1" (Lwr.)	-0	0	1	2	0	0	0	1	3
No Sign Change	0	0	0	0	0	0	1	1	3
Subtr. Div. (Upper) Enter "1" (Lwr.)	-0	0	1	2	0	0	0	1	3
Sign Change	9	9	8	8	0	0	1	2	3
Correct	+0	0	1	2	0	0	0	0	3
	0	0	0	0	0	0	1	2	3
Last Shift	0	0	0	0	0	1	2	0	4
Subtr. Div. (Upper)	-0	0	1	2	0	0	0	0	4
Sign Change	9	9	8	8	0	1	2	0	4
Correct	+0	0	1	2	0	0	0	0	4
Stop	0	0	0	0	0	1	2	0	0

Figure V-42. Division, Using an Abbreviated Accumulator of Eight Positions

entries will be entered at D1L. A carry from D1L detects this condition and sets up an overflow stop.

On a multiply-divide left shift cycle the high-order dividend digit is shifted left from the D10U accumulator position into the DXL accumulator position. From here it enters the adder at D10U time on a divide subtract cycle, from the accumulator early output. The distributor contents are subtracted from the upper accumulator by the usual complement add entry.

A zero is supplied by the distributor zero entry circuit as a DXL distributor early output, to merge with the high-order dividend digit. This zero enters as a complement on a subtract (reduction) cycle and in true form on an add (correction) cycle. When a complement number is added to a true number, a carry from the high-order position indicates that the

result is still a true number and the sign has not changed. No carry indicates that the result is complement and the sign has changed.

This principle is illustrated by Figure V-43 using the previous example of  $1440 \div 12 = 120$ .

This DXL carry or no-carry on a divide subtract cycle is used to determine whether the following cycle will be add or subtract. When an add (correction) cycle is finally set up, its completion signals another multiply-divide left shift cycle.

On each multiply-divide left shift cycle the shift count number in the D0L accumulator position is advanced by one. This number is zero at the start of the divide operation, so it becomes zero and a D0L carry occurs on the tenth shift. After this D0L carry occurs, the completion of the next add (correction) cycle stops the operation instead of signaling a multiply-divide left shift cycle.

PROBLEM:  
1440 ÷ 12 = 120

	ACCUMULATOR									
	DXL	UPPER				LOWER				
	D4	D3	D2	D1	D4	D3	D2	D1	D0L	
Dividend	0	0	0	0	0	1	4	4	0	0
Shift	0	0	0	0	1	4	4	0	0	1
Subtr. Div.	9	9	9	8	7	9	9	9	9 <sup>1</sup>	1
No Carry DXL, Sign Change	9	9	9	8	9	4	4	0	0	1
Correct	0	0	0	1	2	0	0	0	0	1
	0	0	0	0	1	4	4	0	0	1
Shift	0	0	0	1	4	4	0	0	0	2
Subtr. Div. Upper	9	9	9	8	7	9	9	9	9 <sup>1</sup>	2
Carry DXL, No Sign Change	0	0	0	0	2	4	0	0	0	2
Subtr. Div. Upper. Enter "1" Lwr.	9	9	9	8	7	9	9	9 <sup>1</sup>	1	2
No Carry DXL, Sign Change	9	9	9	9	0	4	0	0	1	2
Correct	0	0	0	1	2	0	0	0	0	2
	0	0	0	0	2	4	0	0	1	2
Shift	0	0	0	2	4	0	0	1	0	3
Subtr. Div. Upper	9	9	9	8	7	9	9	9	9 <sup>1</sup>	3
Carry DXL, No Sign Change	0	0	0	1	2	0	0	1	0	3
Subtr. Div. Upper. Enter "1" Lwr.	9	9	9	8	7	9	9	9 <sup>1</sup>	1	3
Carry DXL, No Sign Change	0	0	0	0	0	0	0	1	1	3
Subtr. Div. Upper. Enter "1" Lwr.	9	9	9	8	7	9	9	9 <sup>1</sup>	1	3
No Carry DXL, Sign Change	9	9	9	8	8	0	0	1	2	3
Correct	0	0	0	1	2	0	0	0	0	3
	0	0	0	0	0	0	0	1	2	3
Shift	0	0	0	0	0	0	1	2	0	4
Subtr. Div. Upper	9	9	9	8	7	9	9	9	9 <sup>1</sup>	4
No Carry DXL, Sign Change	9	9	9	8	8	0	1	2	0	4
Correct	0	0	0	1	2	0	0	0	0	4
Stop	0	0	0	0	0	0	1	2	0	0

Figure V-43. Simplified Accumulator Showing Dividend Sign Change

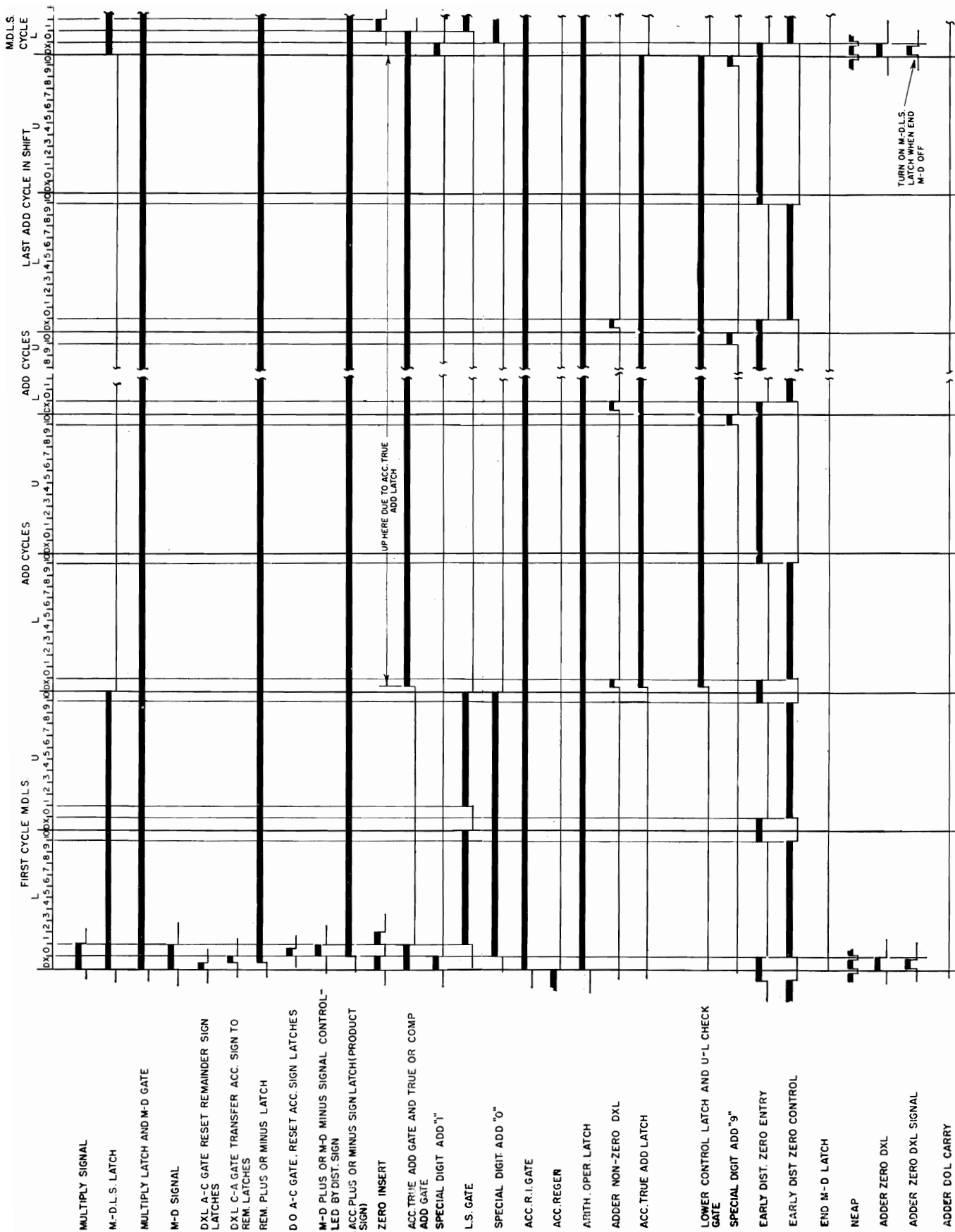

Figure V-41. Multiply Timing Chart

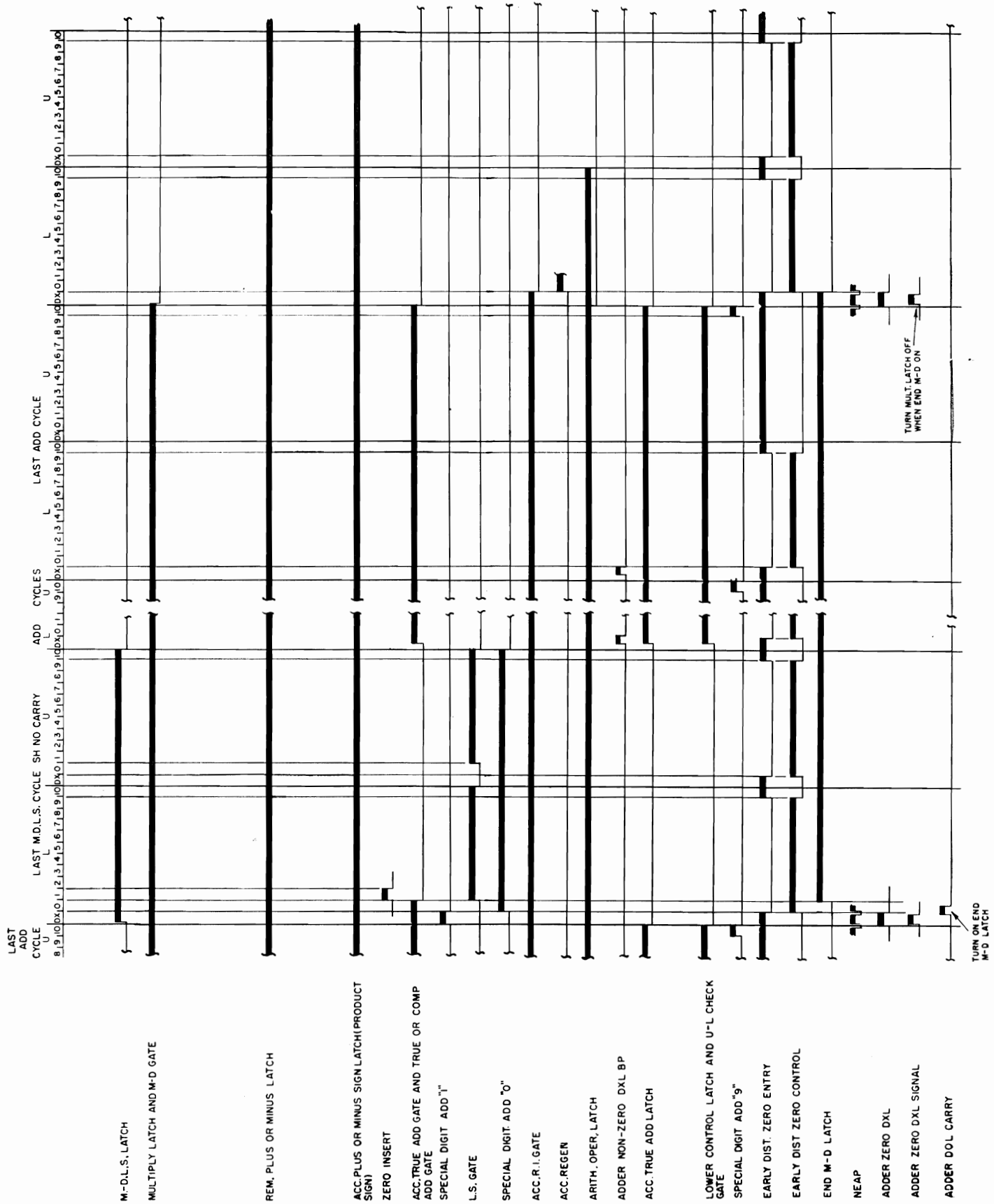

Figure V-41. Multiply Timing Chart (Continued)





## Division Consists of

1. Sign analysis
2. Divide left shift cycles
3. Divide subtract cycles
4. Divide add cycles  
(Figure V-45)

## Major Objective:

Divide the accumulator contents by the contents of the specified D-address.

## Minor Objectives:

1. Read the specified D-address contents into the distributor (Figure V-4).
2. Divide setup (Figure V-46).
3. Set the signs of the remainder and quotient (Figure V-47).
4. Multiply-divide left shift (Figure V-48).
  - a. Divide signal initiates the first left shift cycle.
  - b. End of true add initiates the remaining left shift cycles.
5. Reduce the dividend (divide-subtract)
  - a. End multiply-divide left shift initiates the first subtract cycle following a left shift (Figure V-49).
  - b. DXL carry initiates all subtract cycles except the first (Figure V-50).
6. Develop quotient
  - a. Add one to the D1L position for each true reduction (Figure V-50).
    - (1) During the next divide subtract cycle.
7. Overdraw
  - a. Divisor subtracted one too many times.
    - (1) No DXL carry.
8. Correction cycle (Figure V-51).
  - a. Add divisor to the upper accumulator once.
    - (1) Distributor true add.
9. Multiply-divide left shift (Figure V-48).
  - a. Initiated by end of true add.
10. Reduce dividend, overdraw, correct and left shift until a D0L carry is developed.
11. Turn on end multiply divide latch (Figure V-52).
  - a. Initiated by a D0L carry.
12. Reduce dividend, overdraw then correct.
13. Allow control commutator to advance.
  - a. Turn operation interlock off (Figure V-52).
    - (1) End of operation.

Refer to Figure V-52A for division sequence chart.

On a code 64 the remainder is reset by inserting zeros in the upper accumulator on the last correction cycle of divide.

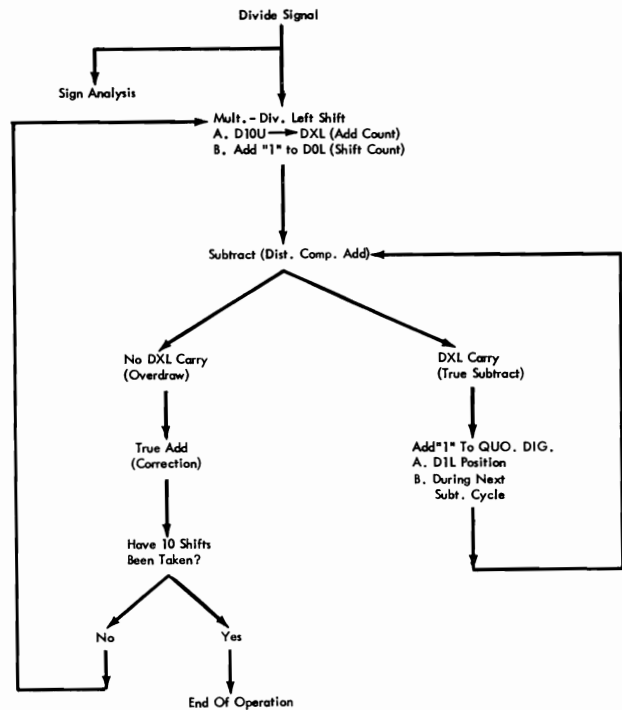

Figure V-45. Divide—Code 14

## General Circuit Action

The first cycle of a divide operation is a multiply-divide left shift cycle. On a multiply-divide left shift cycle the dividend is shifted one position to the left, placing the high-order position in the DXL accumulator position. Any partial quotient which may be in the lower accumulator is also shifted left one position. Also, on a multiply-divide left shift cycle the shift count number in the accumulator D0L position is advanced by one. This number is zero at the start of the divide operation, so it is advanced to one on the first multiply-divide left shift cycle.

When the multiply-divide left shift latch turns off at the beginning of the next cycle, a capacitor-coupled cathode follower pulse switches with the divide latch output to develop a divide-subtract signal which turns on the distributor complement add latch, and the accumulator true add latch. With these latches on, and with the upper control latch on (turned on by the divide latch), the necessary conditions for a subtract upper cycle are set up. Distributor zero entry is active for the lower word time and for all D10 and DX intervals. The divisor (in the distributor) is subtracted from the upper accumulator.

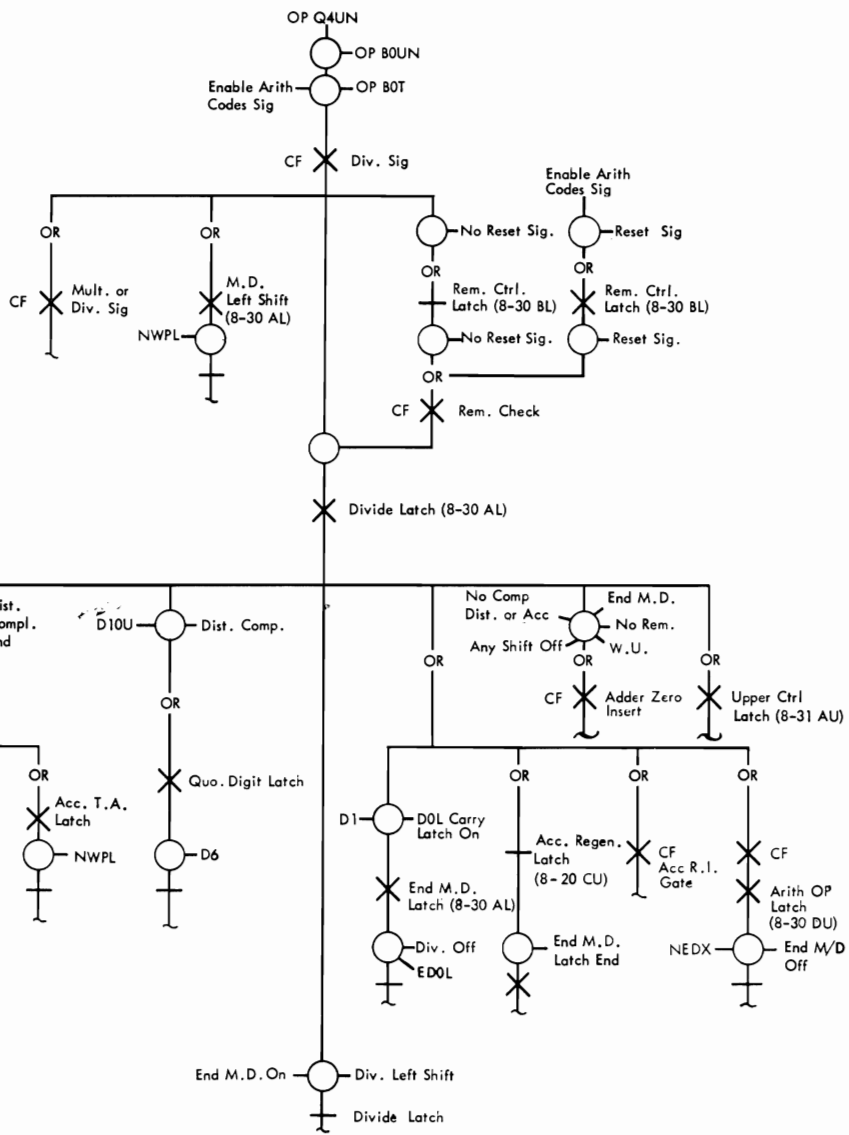

Figure V-46. Divide Controls

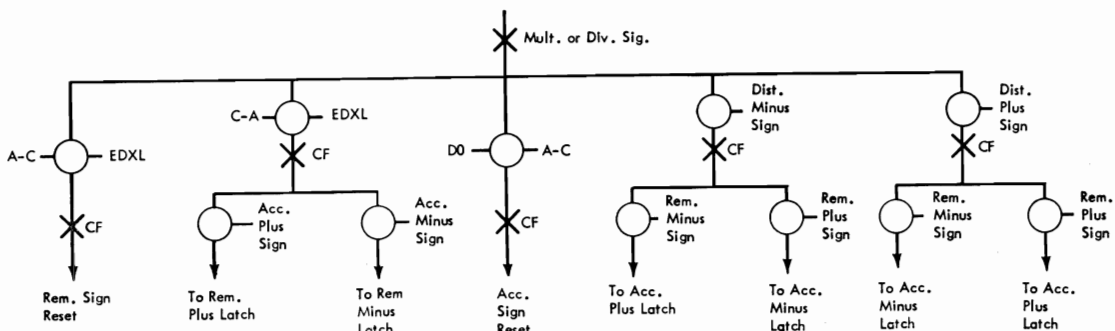

Figure V-47. Divide Sign Analysis

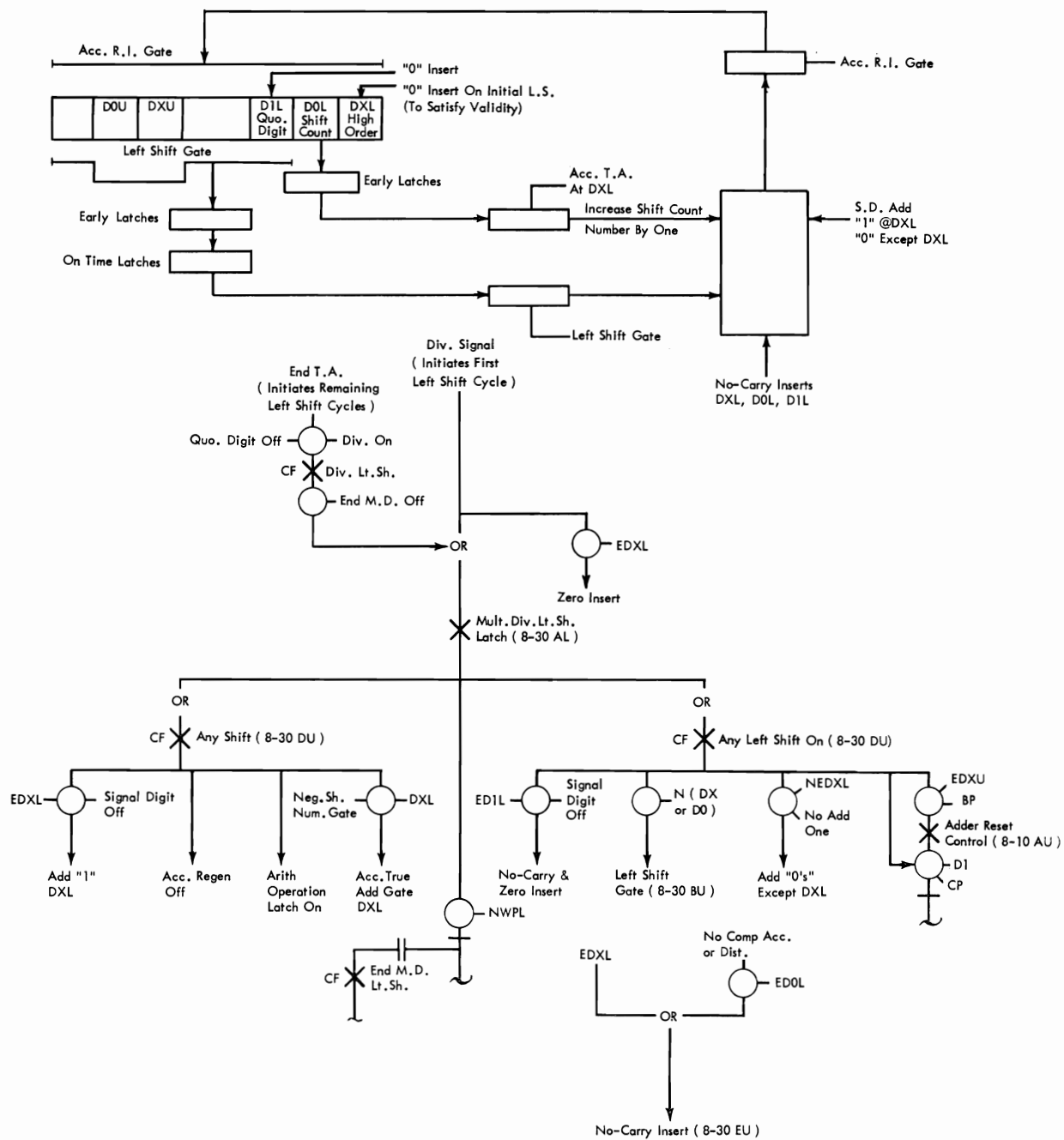

Figure V-48. Divide Left Shift

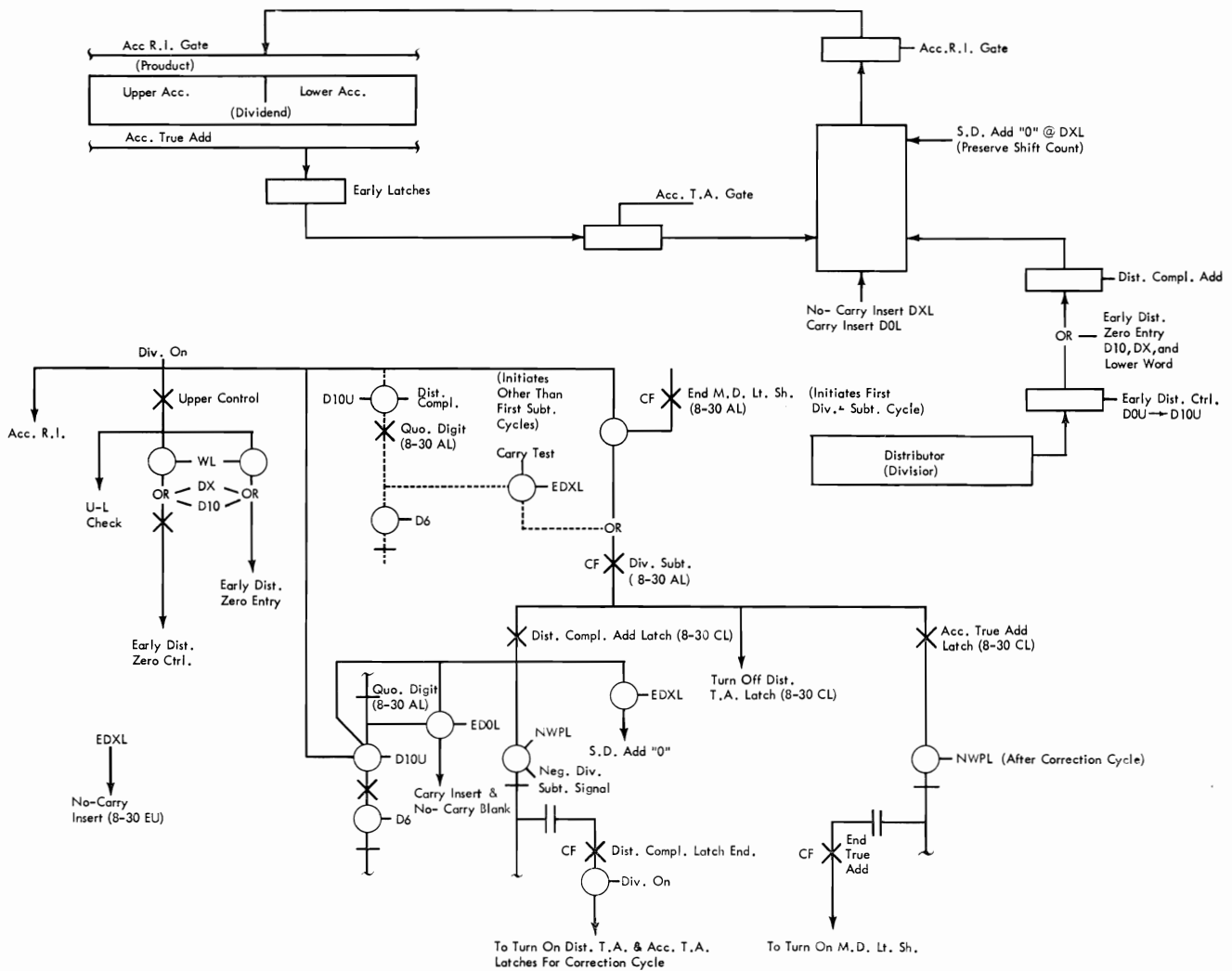

Figure V-49. Divide Subtract—First Cycle

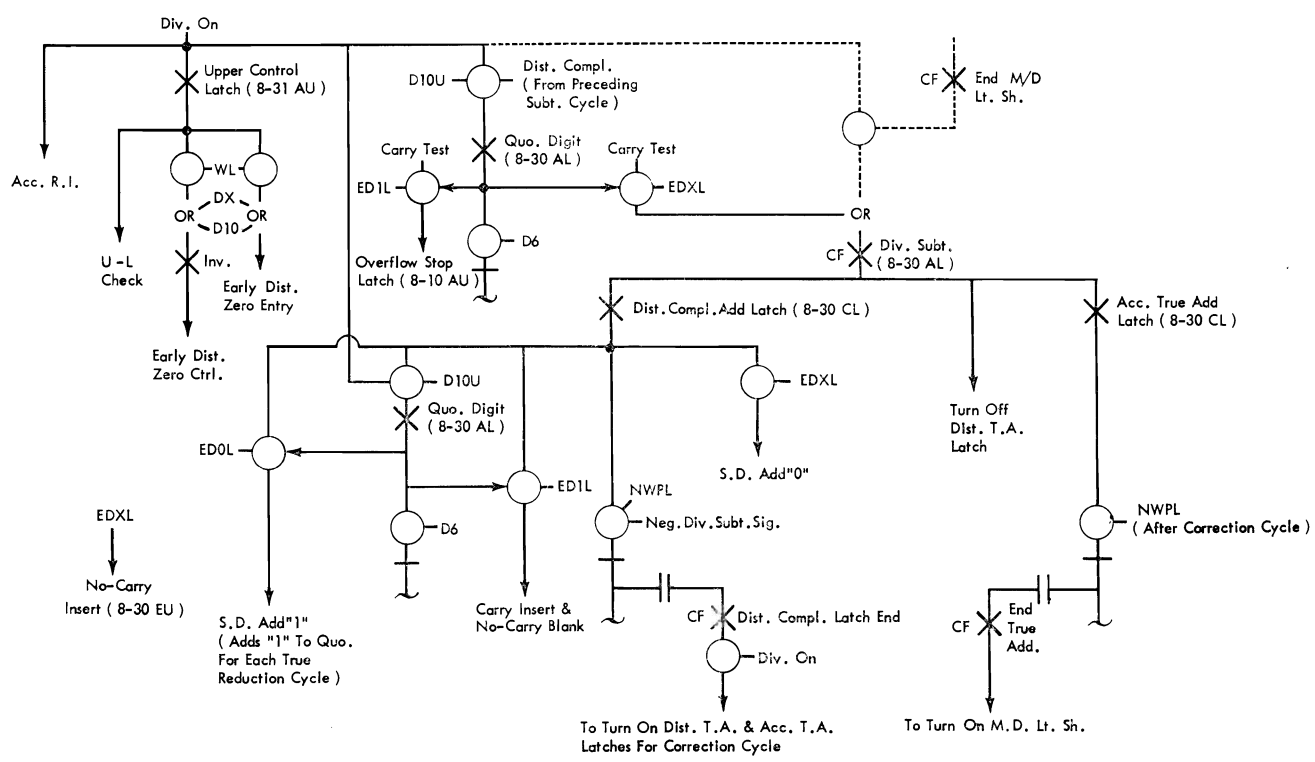
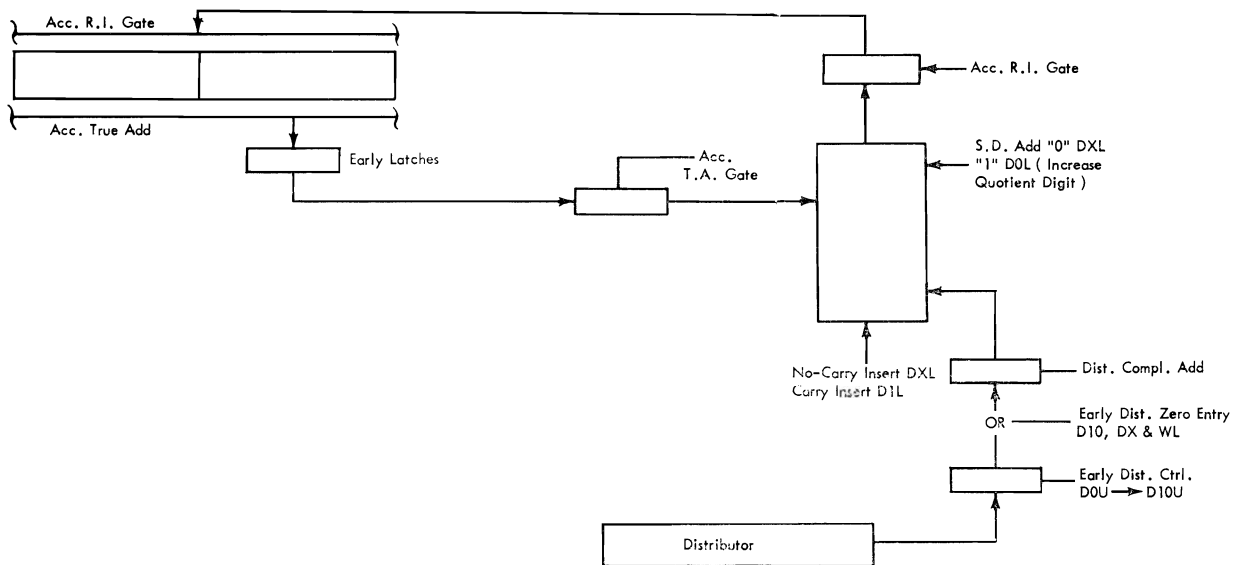

Figure V-50. Divide Subtract—Except First Cycle

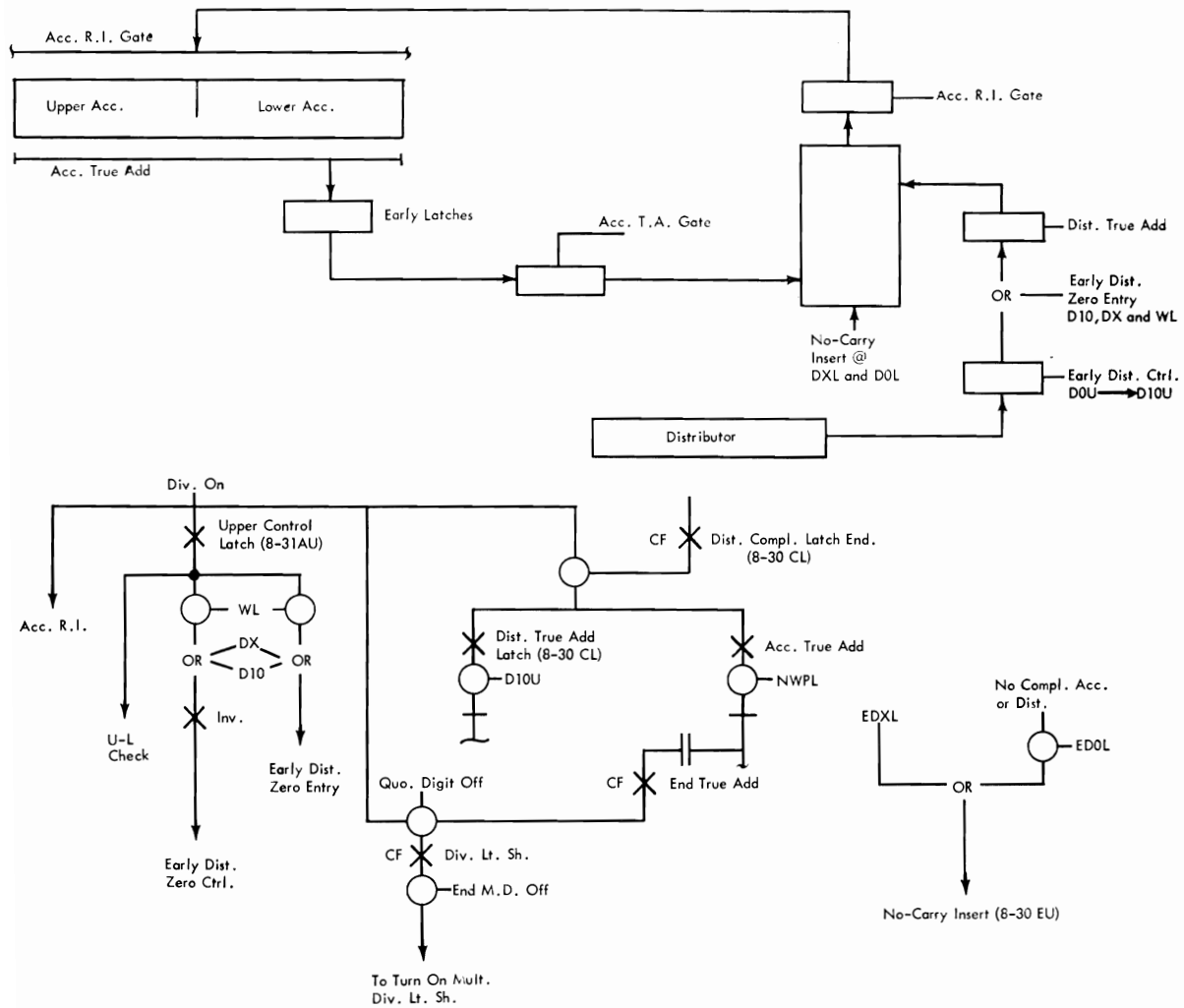

Figure V-51. Divide Add—Correction Cycle

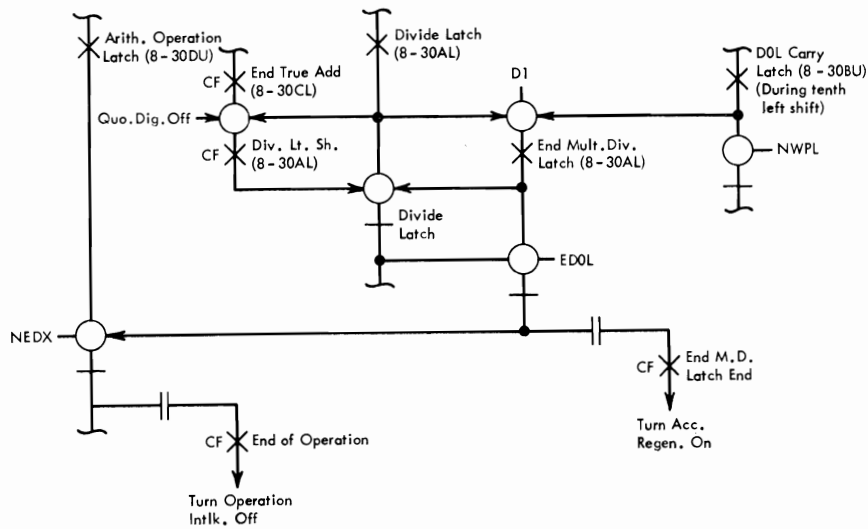

Figure V-52. End of Divide

On this cycle the high order dividend digit in the DXL accumulator position enters the adder at D10U time, merges with a complement zero from the distributor zero entry circuit, and comes from the adder at DXL time to enter the DXL accumulator position. It is the carry or no-carry impulse signal from the adder, during this DXL time, which is tested to determine whether or not the sign of the reduced dividend has changed. The quotient digit latch is turned on at D10U time of each reduction cycle by testing with a D10U timing gate to discover whether or not the distributor complement add latch is on. The quotient digit latch output switches with a DXL timing gate and a carry test to test for a sign change.

If a carry is present, a divide subtract signal is developed, which shunts the NWPL reset of the distributor complement add, and accumulator true add latches, thus holding them on for another reduction cycle. If the distributor complement add latch stays on, the quotient digit latch output switches with distributor complement add and D0L to operate special digit-add one to enter a quotient digit of one during this next reduction cycle.

The quotient digit latch output also controls the carry insert circuit so that a carry is inserted at D1L on all divide complement add cycles except the first one after a shift, instead of at D0L as on other complement add cycles. This inserts the necessary elusive one into the D2L position when dividing, on all cycles when a quotient entry is made in the D1L position; but allows its insertion into the D1L position on the first reduction cycle after a shift, when no quotient entry is made. This is illustrated in the preceding simplified chart of division.

Reduction cycles continue until no DXL carry occurs. No divide subtract signal is developed to shunt the NWPL reset of the distributor complement add latch. As the distributor complement add latch goes off, on a divide operation, a capacitor-coupled cathode follower impulse holds the accumulator true add latch on and turns on the distributor true add latch. With accumulator true add and distributor true add on, the necessary gates are developed to true add the distributor to the upper accumulator, thus providing the correction cycle.

At the end of the correction cycle the accumulator true add latch turns off. A capacitor-coupled impulse, when it goes off, switches with divide latch

on and quotient digit latch off to develop a divide left shift signal which turns the multiply-divide left latch shift on, if the end multiply-divide latch is still off.

This process of shifting, reducing and correcting and the consequent entry of quotient digits continues until the shift count number in the accumulator D0L position is advanced to ten, as indicated by a D0L carry. This carry turns on the end multiply-divide latch. With this latch on, the divide left shift signal at the end of the last correction cycle is prevented from turning on the multiply-divide left shift latch and instead turns off the divide latch to stop the operation.

### TABLE LOOKUP

THE terminology used is defined as follows:

Argument—Known reference factors.

Function—Unknown results associated with the arguments.

Table—An arrangement of arguments in an ascending sequence of absolute values and a series of associated functions.

On a TLU operation the contents of the word locations of the address selected table band are successively compared with the contents of the distributor. This is accomplished by allowing the general storage outputs to enter the adder via entry A and the on-time distributor outputs to enter the adder, in tens complement form, via entry B. An adder DX carry indicates that an equal or next higher argument has been found. If no adder DX carry is detected, the selecting address in the D-address positions (5-8) of the program register and in the address register must be increased by fifty. This is accomplished by running the contents of the program register through the adder during the forty-ninth word interval of the band, adding a five to its D6 position and storing the result back in the program register.

The modified D5 through D8 positions also enter the address register from the program register on-time lines, in the normal manner. The new general storage selection is available from the address register during D5 through D8 of the forty-ninth word interval. The fiftieth word interval allows time for the general storage selection circuits to recover, before being used.



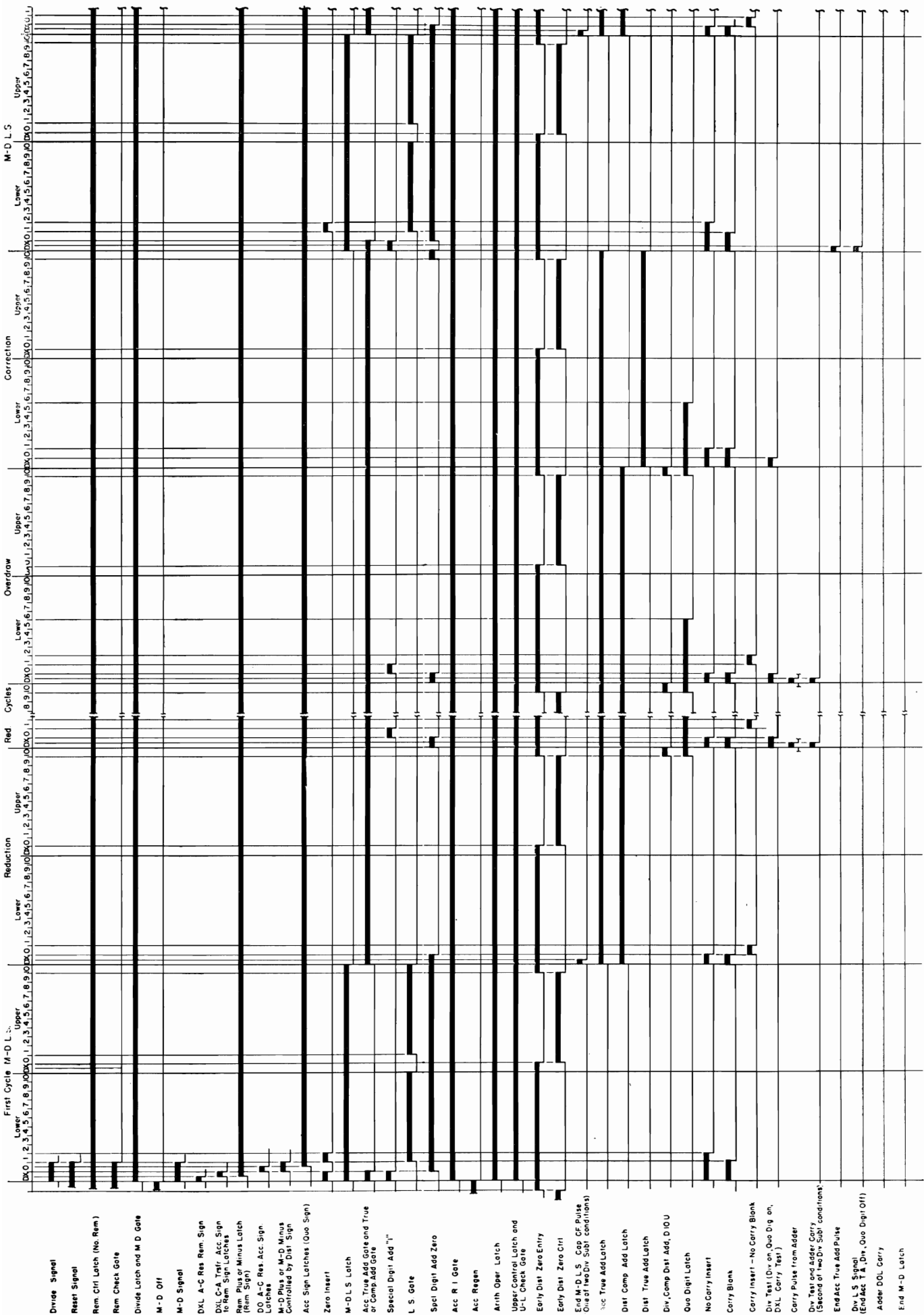

Figure V-52A. Divide Timing Chart

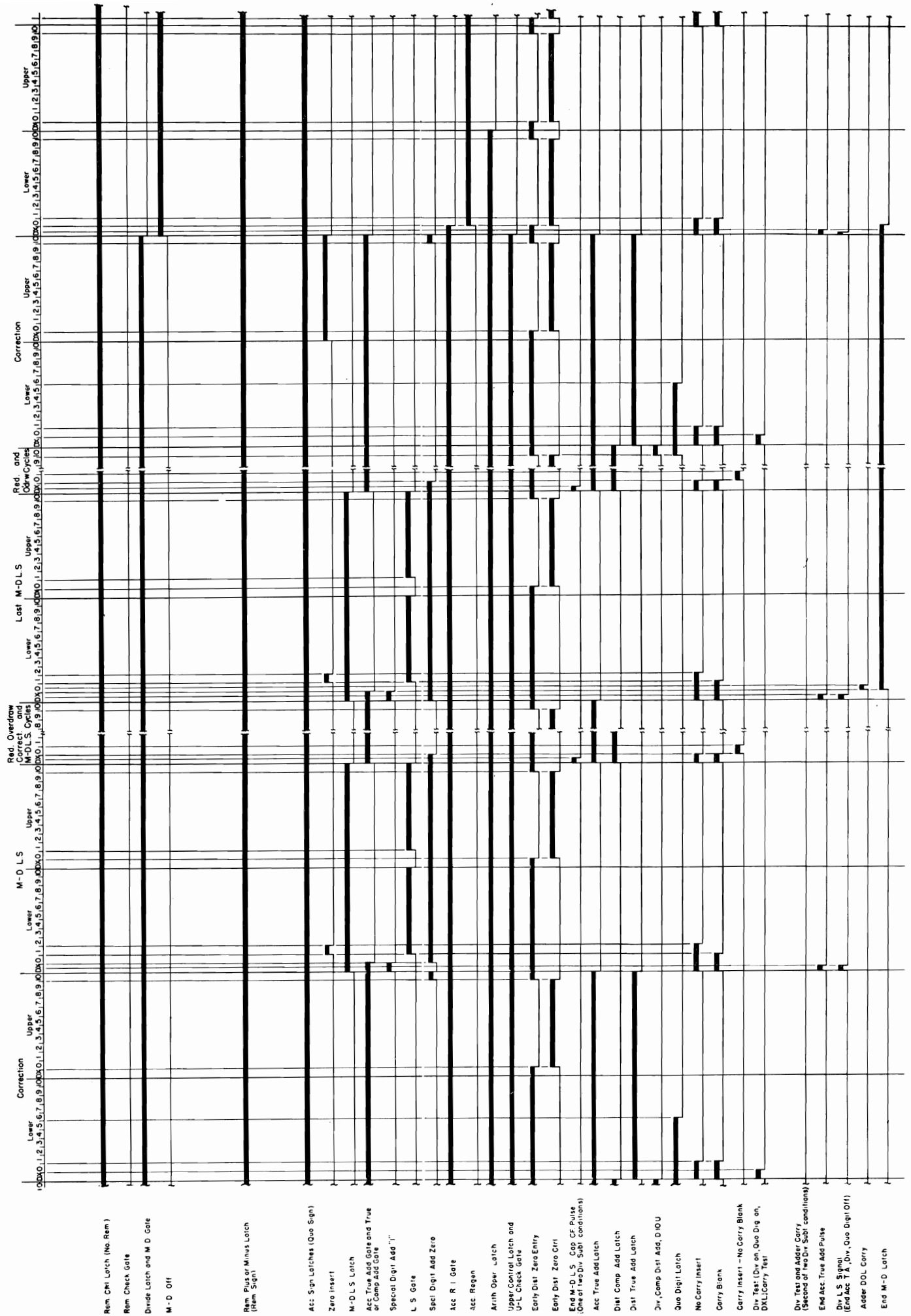

Figure V-52A. Divide Timing Chart (Continued)

- Minor Objectives:  
 I. Setup from code 84  
 A. Table Look-up Control Latch

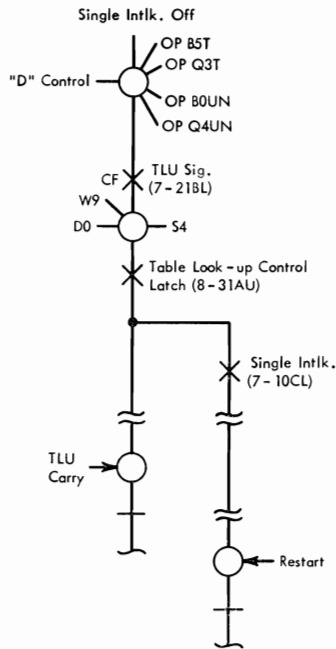

Figure V-53. Table Lookup Setup—Code 84

The search continues as before until an adder DX carry is detected. When a DX carry is sensed, a number equal to the drum word interval during which the DX carry was sensed is added to the modified address in the program register. Thus, the general storage address of the equal or next higher argument is found. This addition is done on a program register add cycle, during the word interval following the one on which the DX carry is detected. The value of the number which is added is determined by the sector and word timing interval during which the DX carry is detected.

After the desired address is in the program register an additional cycle is taken, during which the program register enters the adder, merges with zeros and the adder output for D5 through D8 is allowed to enter the lower accumulator.

**Major Objectives:**

1. Search the table of arguments until one is found that is equal to the search argument; or if there is no equal, locate the next higher argument.

- II. Search the Table of Arguments  
 A. Compare in the Adder, drum readings and distributor output.  
 1. Test for DX carry

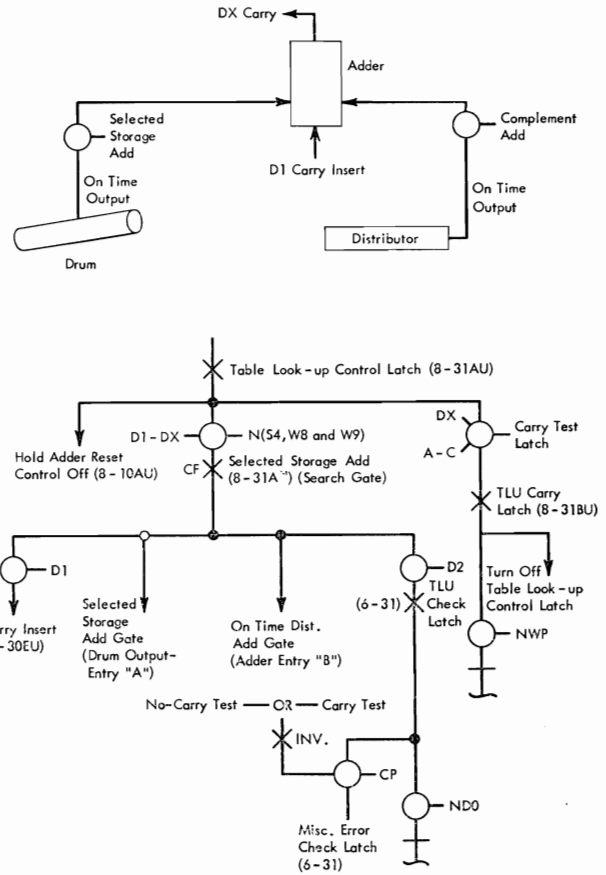

Figure V-54. Table Lookup Search

NOTE: The search argument is in the distributor as the result of a previous operation.

2. Modify the D-address contents of the program register to indicate the general storage address location of the argument found.

3. Read the modified program register D-address contents into D5-D9 positions of the lower accumulator.

TLU (Code 84) is complete when these three objectives have been accomplished. Further programming is necessary to make use of the argument located.

**Minor Objectives: (Figure V-58)**

1. Setup code 84 (Figure V-53)
  - a. Table lookup control latch.

2. Search the table of arguments (Figure V-54)
  - a. Compare in the adder, drum readings and distributor output.
    - (1) Test for DX carry
    - (2) No special treatment of DXU and D0U
      - (a) Hold adder reset control latch off.
  3. Band change: search the next band if the argument is not found in the first band (search and band change until the argument is found, Figure V-55).
    - a. Add 0050 to contents of program register's D-address.
      - (1) No special treatment of DXU and D0U
        - (a) Hold adder reset control latch off.
    - b. Read modified D-address into address register
      - (1) Reset
      - (2) Read-in
  4. Program register adjust: modify the D-address of the program register to indicate the angular location of the argument found (Figure V-56)
    - a. DX Carry

5. Program to accumulator add (Figure V-57).
  - a. Add program register to lower accumulator, digit positions 5, 6, 7, and 8.
6. Restart Signal (Figure V-57)

### Table Lookup Check Circuit (Figure V-54)

In line with the self-checking features of the 650, there is also a table lookup check circuit built into the machine. The basis of this checking circuit is that when valid information is entered into the adder, there will be either a carry or no-carry at each digit time. The circuit shown on wiring diagram 6-31 checks to make certain there is either a carry or no-carry from the adder on a TLU operation.

This condition may be utilized to advantage when testing the drum. A TLU operation may be programmed to search the entire drum. If any reading failure occurs from the drum, the machine will stop and identify the drum location. An analysis of the missing or extra bits will disclose head failures.

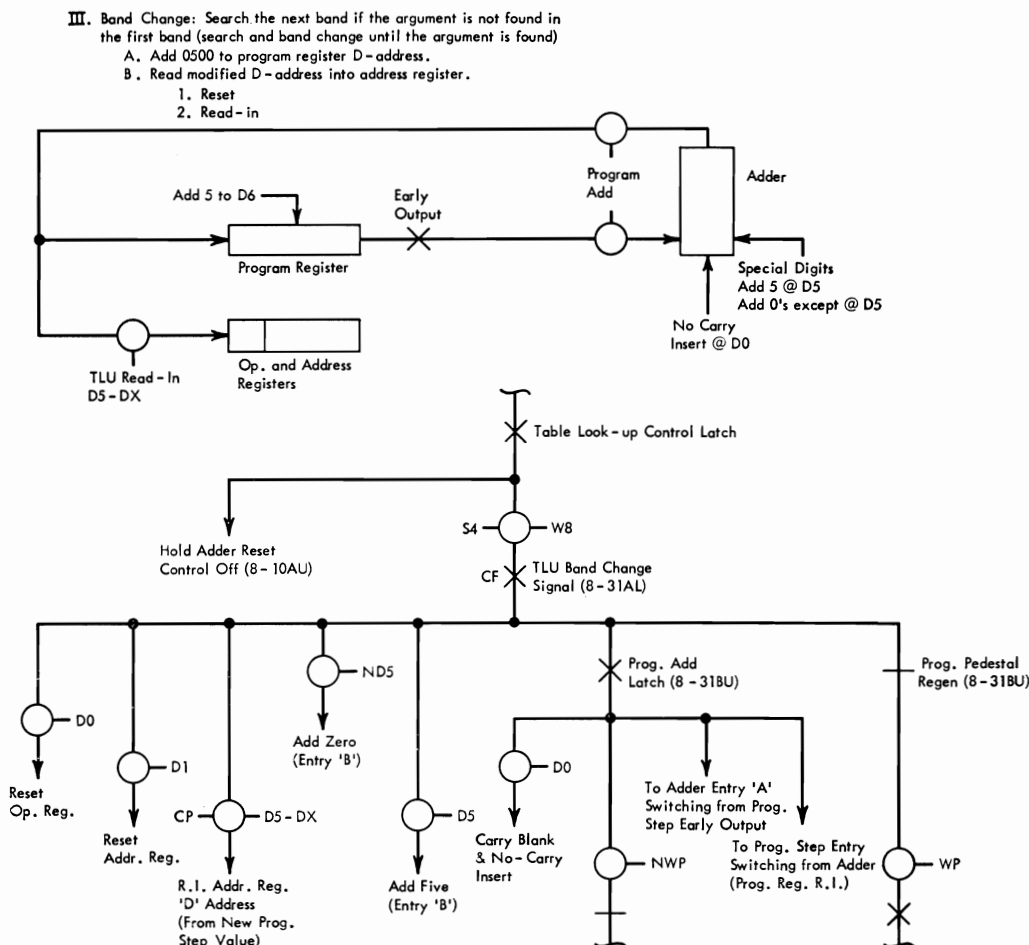

Figure V-55. Table Lookup Band Change

IV Program register adjust: Modify the D-address of the Program Register to indicate the angular location of the argument found.  
 A. DX Carry

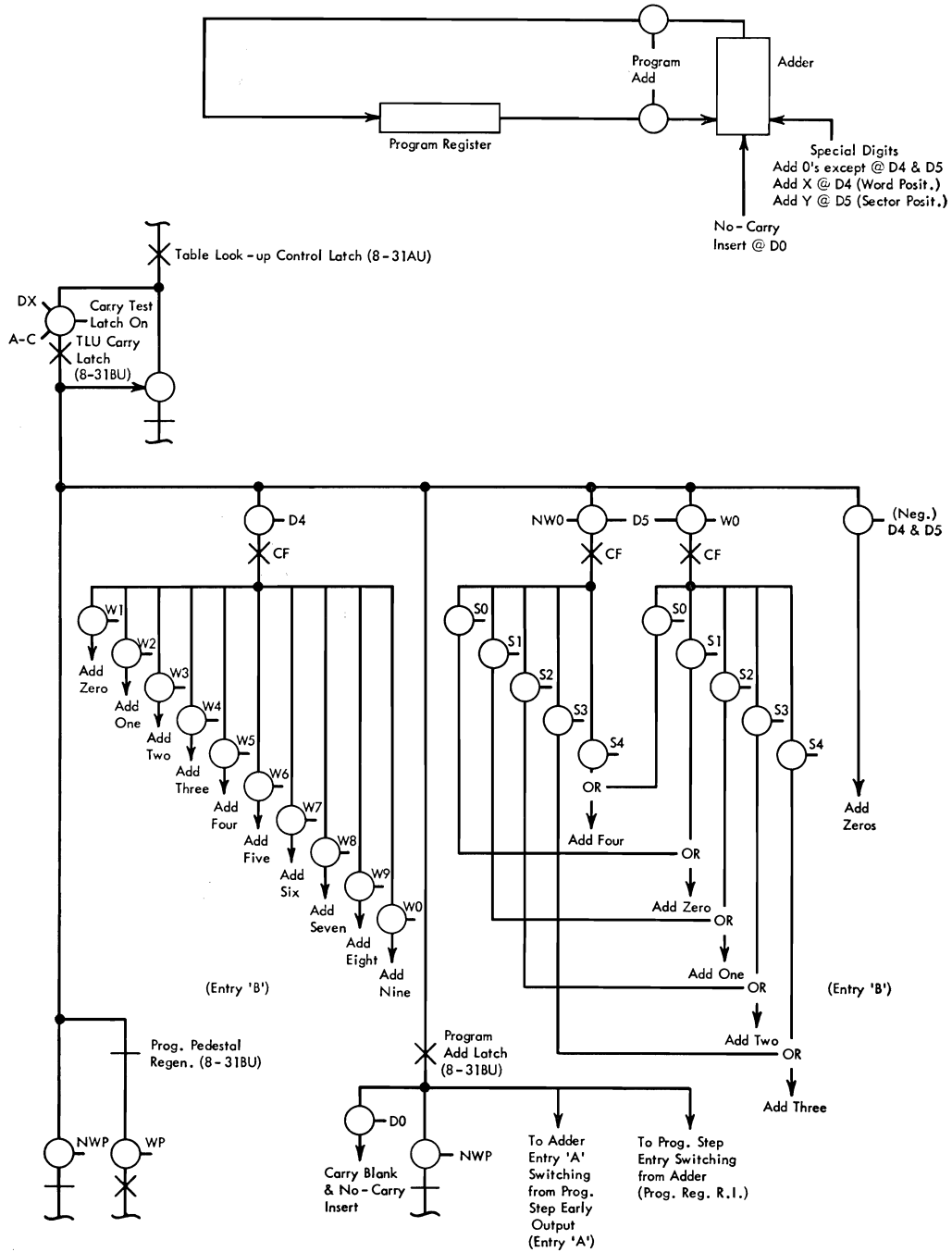

Figure V-56. Table Lookup Program Register Adjust

V. Program to Accumulator Add.  
 A. Add program register to lower accumulator, digit positions 5,6,7, and 8.

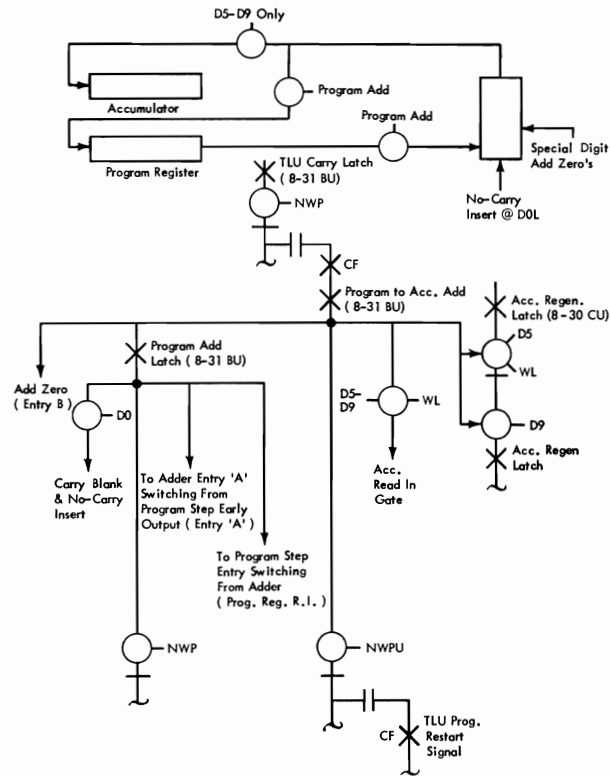

Figure V-57. Table Lookup Program to Accumulator Add

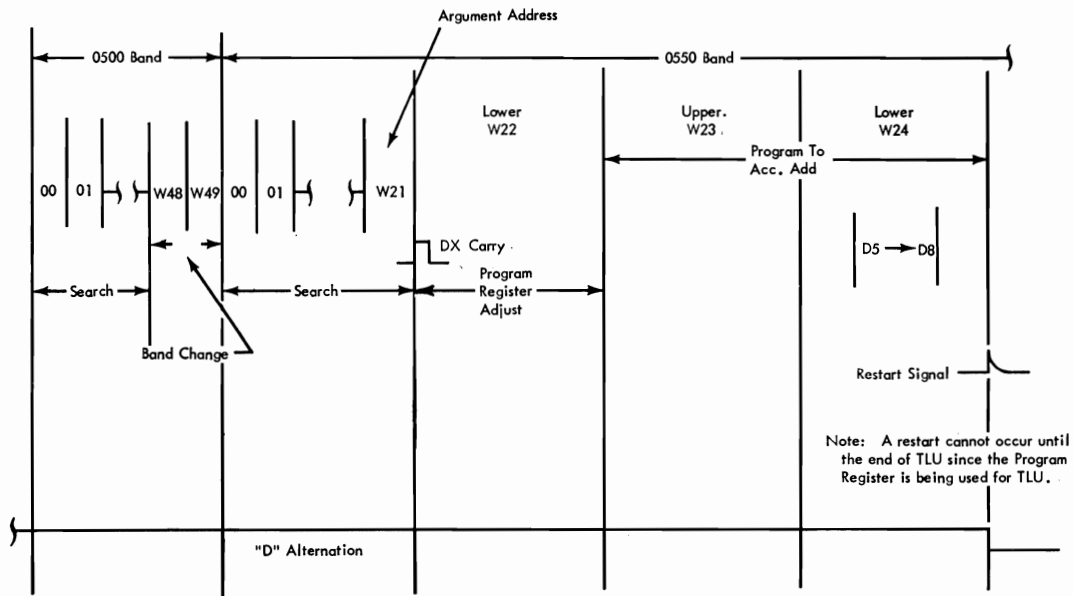
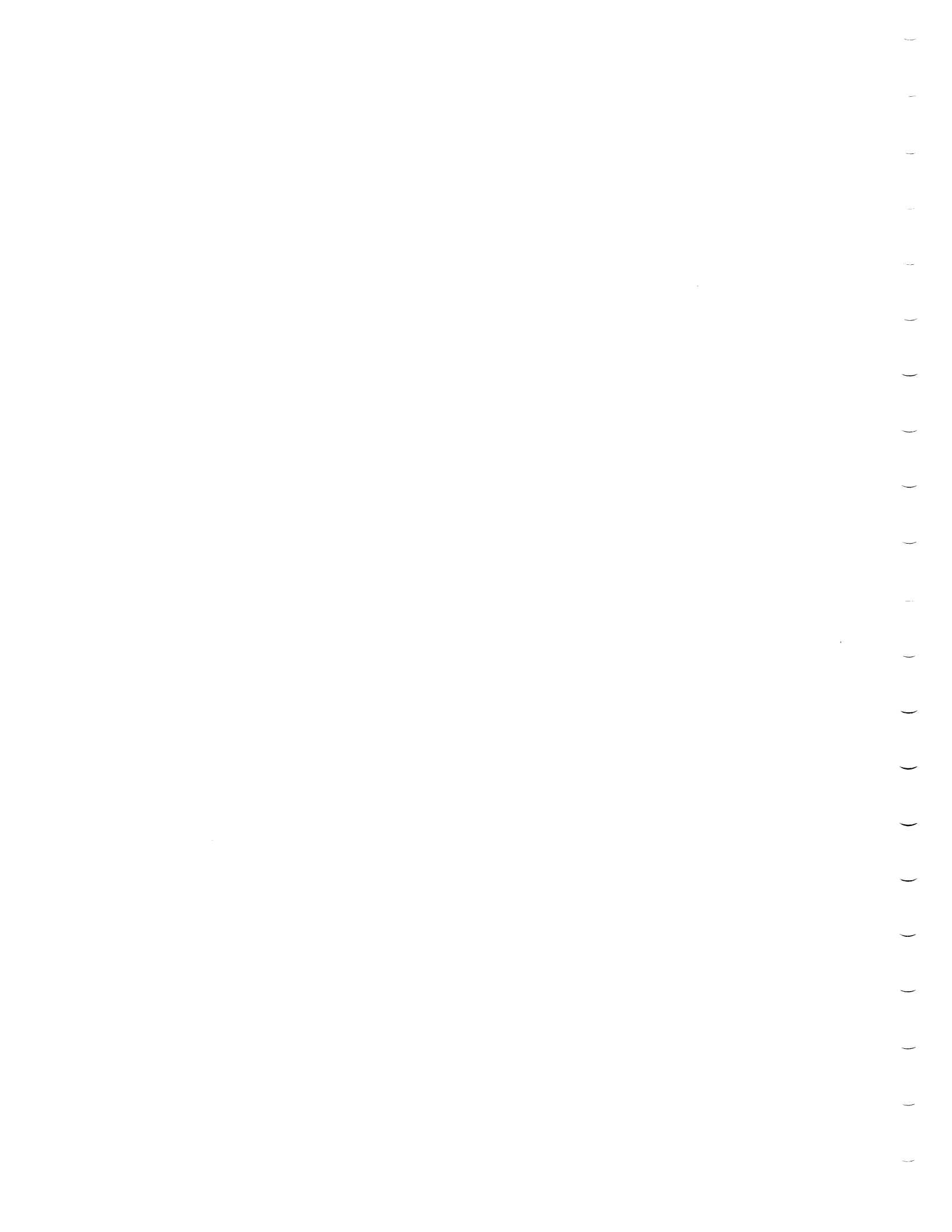

Figure V-58. Table Lookup Timing Chart



## SECTION VI. MANUAL OPERATION

### MANUAL READ-OUT STORAGE OPERATION

MANUAL read-out storage is provided to allow the contents of any general storage location to be displayed. This is accomplished from the control console, as explained in the manual of operation by the following steps:

1. Stop the program.
2. Set the control switch to MANUAL.
3. Set the display switch to READ-OUT STORAGE.
4. Set the address of the location whose contents are to be displayed in the address selection switches.
5. Depress the program reset key (address register reset to blanks).
6. Transfer the address from the address selection switches to the address register by depressing the transfer key.
7. Depress the program start key.

The control commutator functions in such a way that when the specified general storage location is selected, its contents are transferred to the distributor and displayed from there. The control commutator actually functions in rather special ways in accomplishing both manual read-out storage and manual read-in storage operations.

#### Major Objective:

Display the contents of a specified general storage location.

#### Minor Objectives: (Figure VI-1)

1. Find the drum location.
2. Read the contents of the drum location into the distributor.
3. Restart
  - a. Reset operation and address registers.
4. Turn run latch off.

### MANUAL READ-IN STORAGE OPERATION

MANUAL read-in storage is provided to allow the insertion of any desired numeric word into any

general storage location. This is accomplished from the control console, as explained in the manual of operation by the following steps:

1. Stop the program.
2. Set the control switch to MANUAL.
3. Set the display switch to READ-IN STORAGE.
4. Set the word to be entered in the storage entry switches.
5. Set the address of the general storage location where the word is to be entered in the address selection switches.
6. Depress program reset key.
7. Transfer the address from the address selection switches to the address register by depressing the transfer key.
8. Depress program start key.

The control commutator functions to transfer the contents of the storage entry switches to the distributor and then further transfer the contents of the distributor to the specified general storage location. The contents of the distributor are displayed. The entire operation is similar to a store code (20's) except that the word to be stored is taken from the storage entry switches.

#### Major Objective:

Transfer the contents of the storage entry switches to the specified general storage location.

#### Minor Objectives: (Figure VI-2)

1. Transfer the contents of the storage entry switches to the distributor.
  - a. Heat 8000
    - (1) Allows the contents of the storage entry switches to appear on the selected storage data flow path.
  - b. Read-in distributor.
2. Find the drum location.
3. Read-in general storage.
4. Restart
  - a. Reset operation and address registers.
5. Turn run latch off.



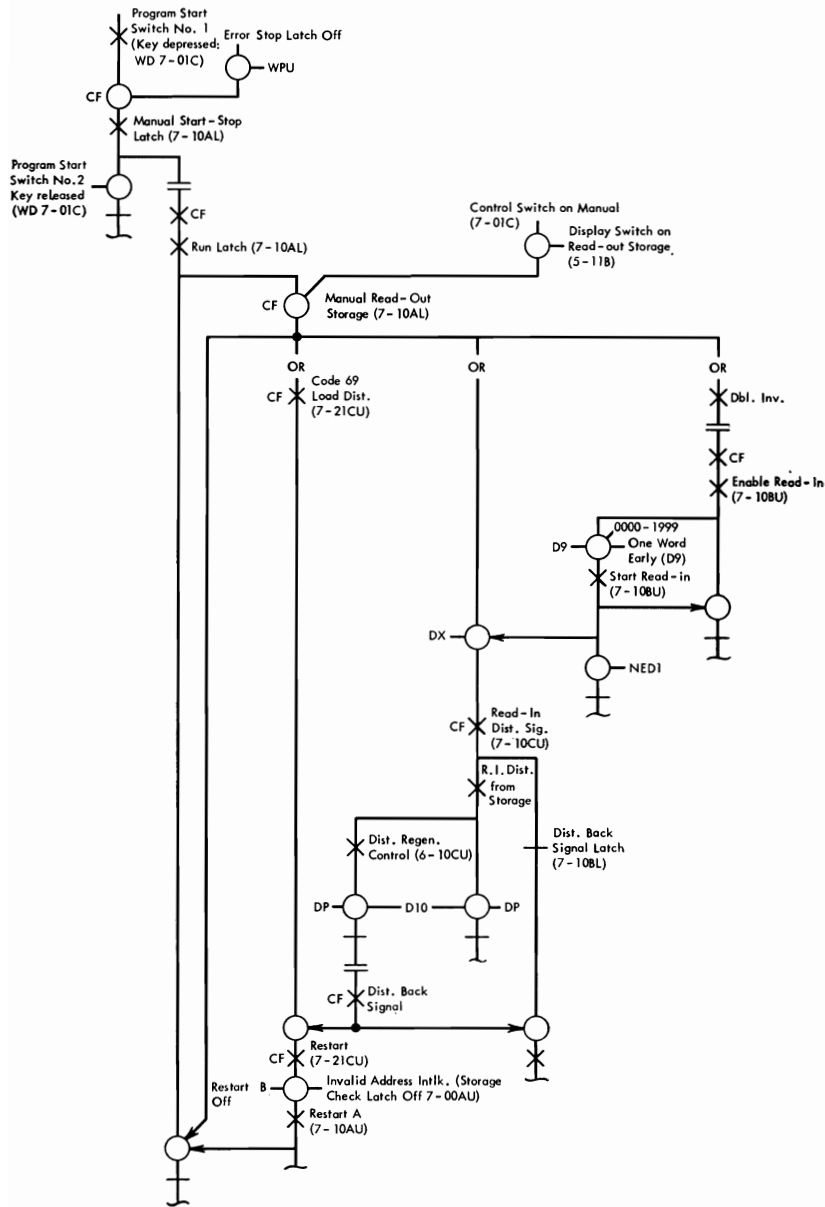
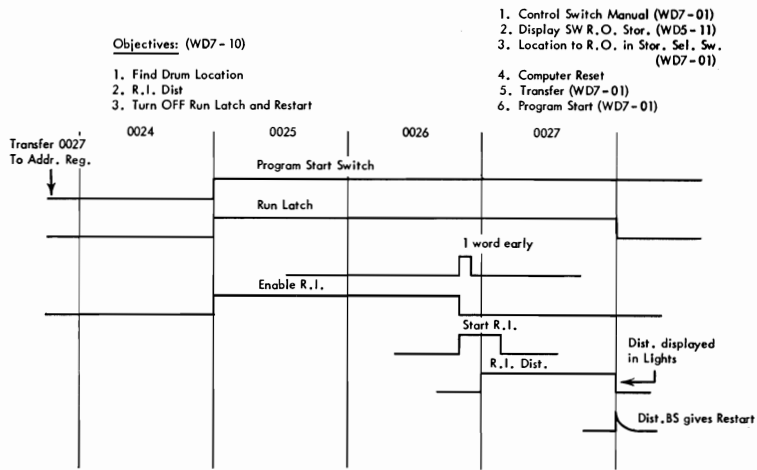

Figure VI-1. Manual Read-Out Storage

**Objectives:** (WD7-10)

1. R.I. Dist. from Switches
2. Find Drum Location
3. RIGS
4. Restart

**Setup**

1. Control Switch Manual (WD7-01)
2. Display Switch R.I. Storage (WD5-11)
3. Location to R.I. in Address Selection Switches (WD7-01)
4. Computer Reset (WD7-02)
5. Transfer (WD7-01)
6. Program Start (WD7-01)

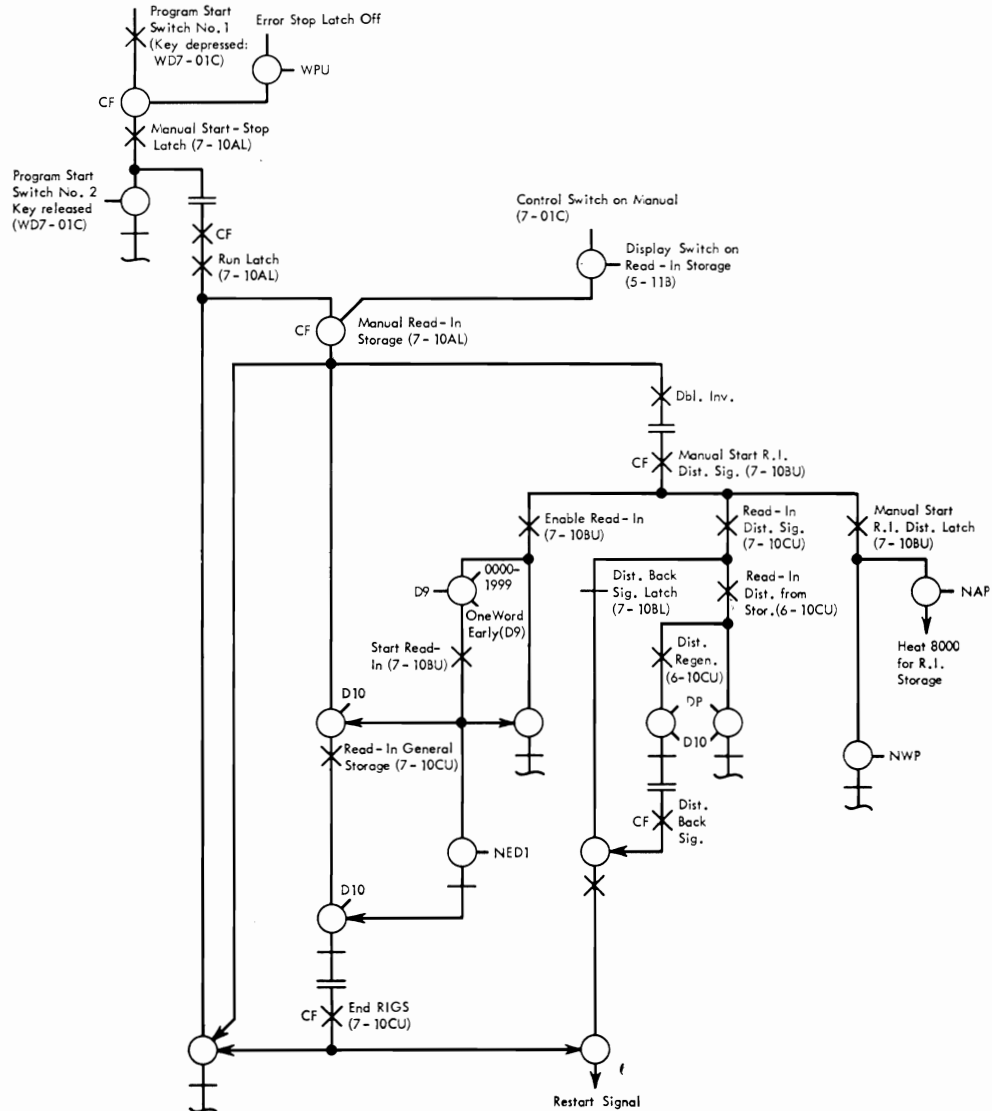
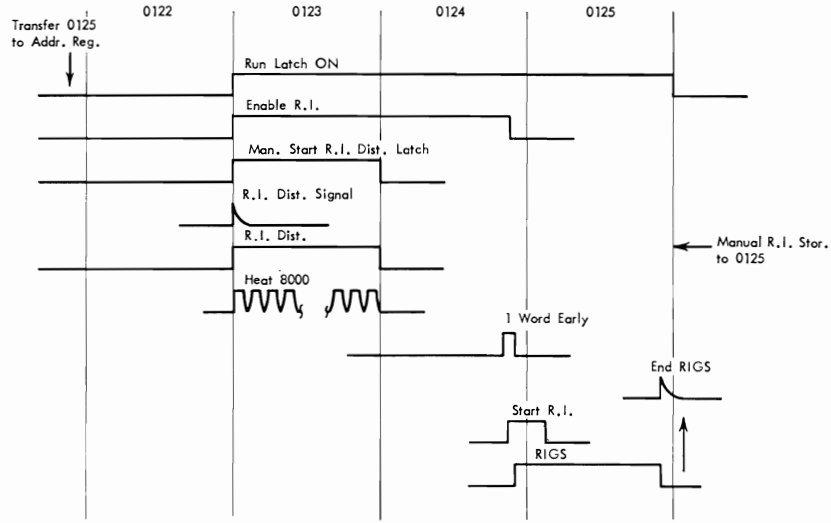

Figure VI-2. Manual Read-In Storage



## SECTION VII. INPUT AND OUTPUT CODES

THE 655 power unit contains circuits which serve two main purposes.

1. The conversion of card information into the proper information gates for input to read-buffer storage and the conversion of punch-buffer storage information gates into a form suitable for punching.
2. Main power supply for the 650 machine.

### CONVERSION CIRCUITS FOR READ-IN AND PUNCH OUT

CHASSIS 13 and 14 in the 655 contain much of the circuitry used in transferring information between cards and drum storage.

Refer to *Drum Arrangement* section for general information on buffer storage functions.

#### Read-In from Card (Code 70) (Figures VII-1 to VII-5)

##### General Circuit Action

Ten words of information may enter RBS on each read operation. These ten words can then be transferred to the word one through word ten locations of any general storage band on a subsequent read operation. Figure VII-1A shows the time during which the digits of these ten words must be available from general storage. To be available from general storage on-time (as shown in Figure VII-1A), information must have been presented to general storage during a time interval one digit early (Figure VII-1B). Thus, the successive B-A information gates, representing the ten words of information in RBS, must be available from the RBS output latches one digit early and must be gated through to the general storage input lines by a ten-word gate, which is one digit early.

In order for information to be available from the buffer storage output latches one digit early it must be presented to the buffer storage record circuits two digits early, during the time shown in Figure VII-1D.

Because of the length of the lines and intervening units, information gates are delayed considerably between the output of the scan circuits and the input to buffer storage. To insure that information will be two digits early at buffer storage input, it is scanned

from the card three digits early. The delay is then controlled by the scan delay latch with the result that two-digit-early information gates, which nicely overlap the write sample pulses, arrive at the buffer-storage record circuits. This delay action is shown in Figure VII-1.

The information gates from the read scan circuits are controlled by the output of the RBS timer so that they can reach the buffer-storage input only during the two-digit early, ten-word interval associated with RBS. The RBS timer establishes the basic RBS timer interval. Its output is also used by the buffer-storage transfer and erase control circuits in the development of the RBS to GS transfer gate and the BS erase gate for erasure of RBS. Its output is shown in Figure VII-1F.

The output of the read scan circuitry is a series of three-digit-early, B-A, digit gates. Each of these gates is produced by its own cathode follower, which serves to associate a specific card column with a specific digit position of drum storage. Note that the cathode follower has anode voltage applied by action of a brush reading a hole in the card. When one of these gates occurs during the time that the RBS timer is on, it turns on the scan delay latch whose output is a D-C gate (approximately  $2\frac{1}{2}$  digits early).

The presence of one of these scan delay gates is an indication that a digit is to be recorded in RBS in the digit and word position represented by the time of occurrence of the gate. The numerical value of the digit to be recorded is established by the reader CB time during which the gate occurs. The single D-C scan delay gate is converted to two of seven bi-quinary form by the bi-quinary cathode followers. Anode voltage is applied to these cathode followers by emitters synchronized with the read feed. Thus, at zero CB time only bi-quinary zeros can be generated, and so on.

As a result of this circuit action on read feed cycles, two and one-half digit early bi-quinary information gates are sent to buffer storage during each successive digit interval included in the RBS timer gate. Zeros are entered on one drum revolution during zero CB time, ones on a later revolution during one CB time,

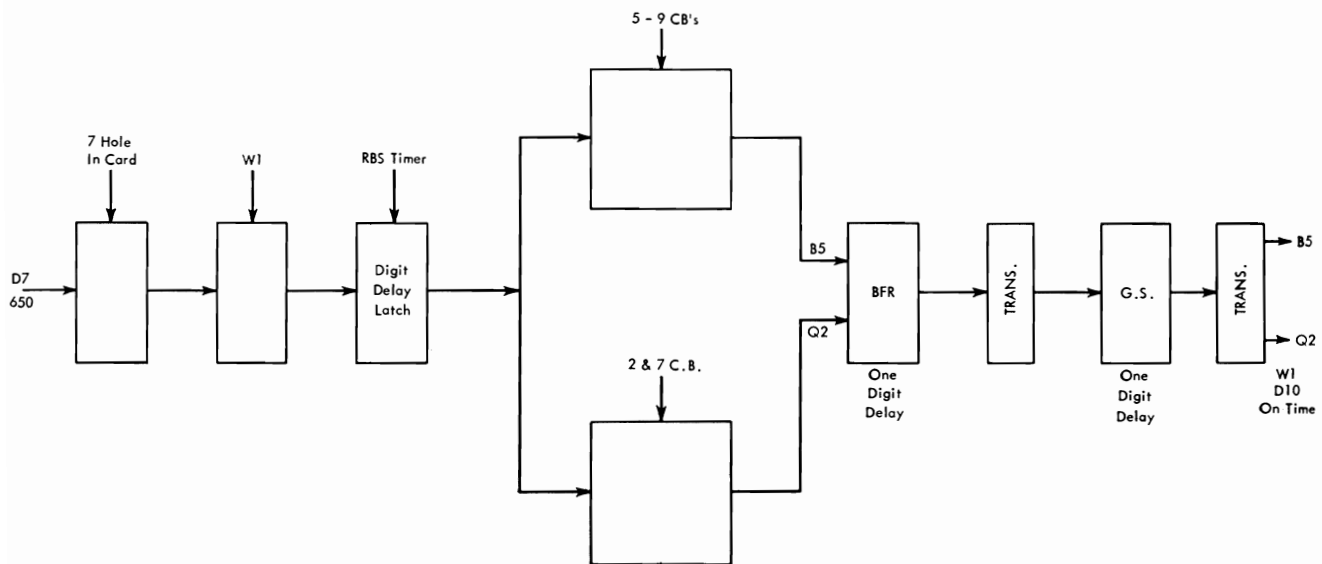
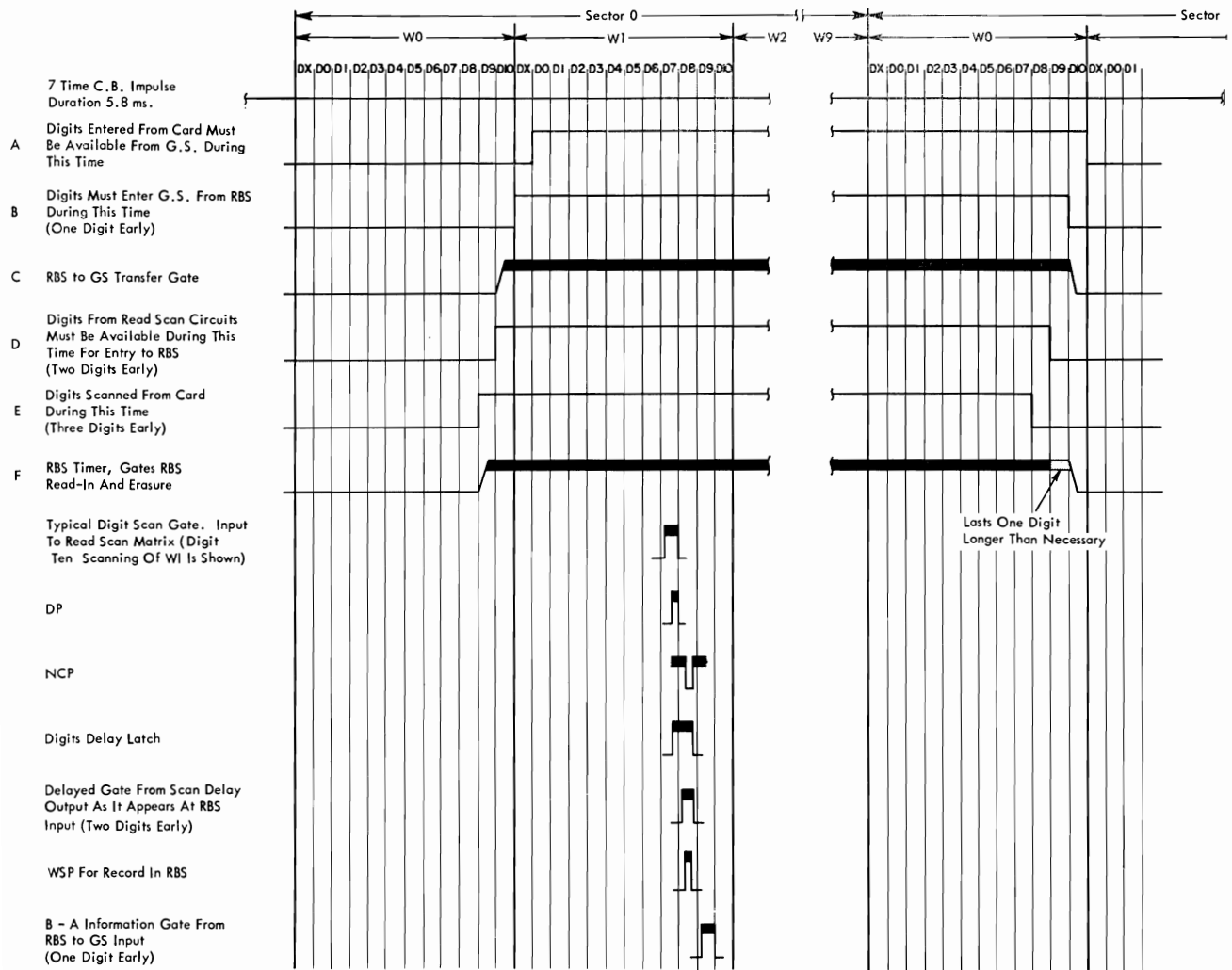

Figure VII-1. Card-to-General Storage: Read "7" Hole to W1, D10

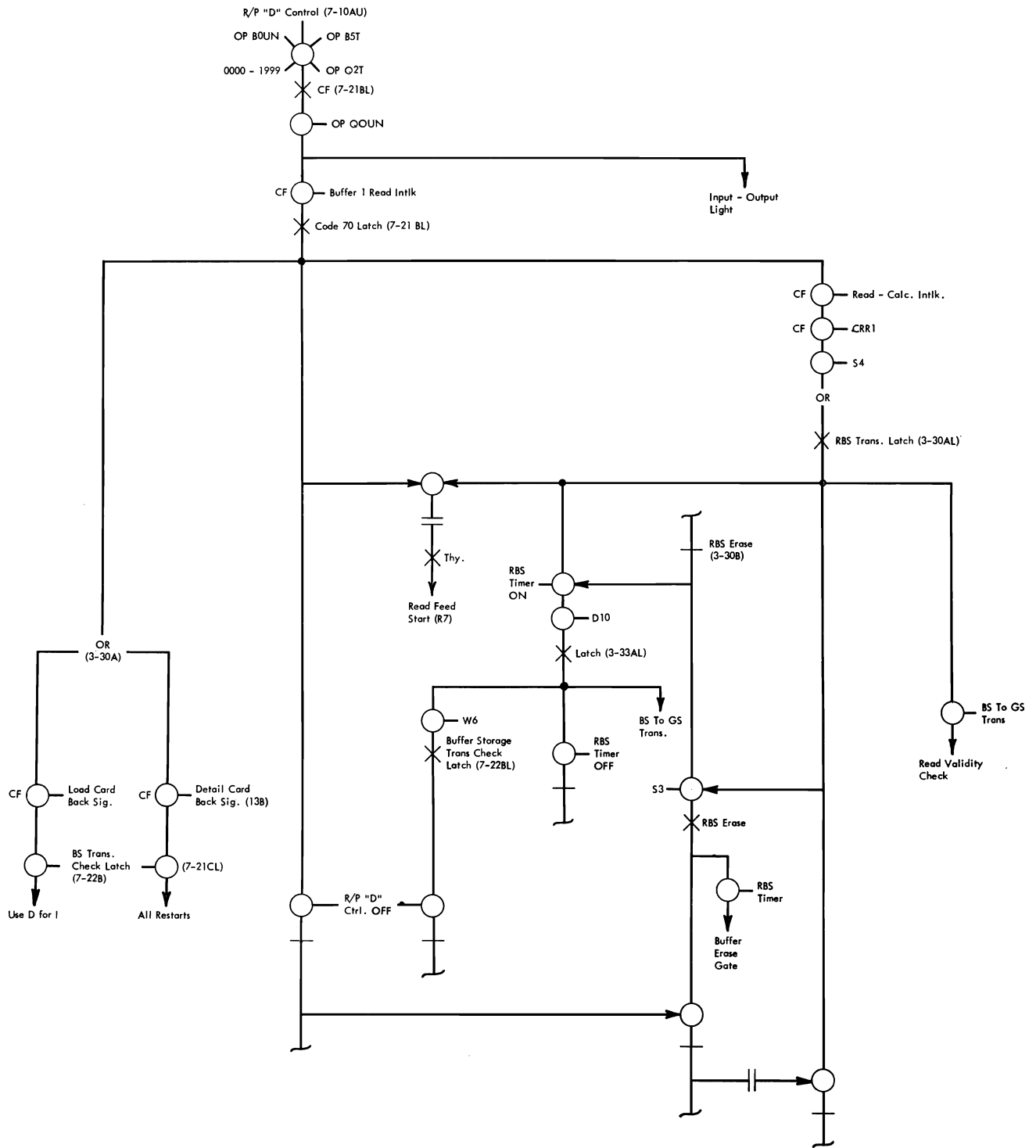

Figure VII-2. Read—Code 70

etc. These gates, which are two and one-half digits early at the bi-quinary cathode follower outputs, are delayed in passing through subsequent components and in the lines between chassis 14, chassis 8 and chassis 6, so that they are two digits early at the point on chassis 6, where they are switched with write sample pulses.

The BS transfer and erase control circuits are activated by a signal from the read code latch when a 70 code is sensed. These circuits develop the RBS to GS transfer gate and the BS erase gate, resulting in the transfer of the contents of read-buffer storage to general storage and the erasure of read-buffer storage to blanks. The transfer and the erasure occur on two successive drum revolutions at the very start of the read cycle, before card read time.

Code 70 switched with RBS transfer activates the read clutch thyatron circuit and sets into operation a timed series of events resulting in energization of the read clutch magnet at the proper mechanical time for the pawl to catch one of the clutch ratchet teeth.

The read code latch output switches with CRR1 and the next sector 4 timing pulse to turn on the RBS transfer latch. This latch stays on through its direct latchback circuit, until turned off by the erase latch turning off. While on, this latch provides the RBS to GS transfer gate, and switches with S3 to turn on the BS erase latch.

Note that the buffer storage output latches continually respond to recorded bits in the buffer storage tracks, at both RBS time and PBS time. Thus, during the time that the RBS to GS transfer gate is up, the contents of RBS are transferred to the word one through ten positions of the GS band selected by the D-address accompanying the 70 code. This transfer takes place on a drum revolution which occurs very early in the read feed cycle, possibly even before the clutch pawl has engaged a ratchet tooth.

RBS transfer switches with a S3 pulse to turn on the erase latch. Because RBS transfer goes on at S4 time, the erase occurs on the drum revolution following buffer storage to general storage transfer.

The association of a card column with a specific digit of a specific word of read-buffer storage is accomplished by the matrix circuit consisting of 110 cathode followers shown in WD 2-01. There is

one cathode follower for each digit position of each of the ten RBS words. Each cathode follower is associated with a digit of a word by action of the digit timing pulses, which drive its grid and the diode switching circuits that restrict its output to a specific word interval. Anode voltage is applied to a cathode follower by the reader impulse CB's when a read brush makes contact through a card hole. Read brushes are pluggable to storage entry on the 533 control panel so that any card column can control any cathode follower.

## Code 70

### Major Objective:

Transfer data from card in reader to 650 general storage.

### Minor Objectives (Figure VII-2):

1. Initiate reader start.
2. Transfer from RBS to the 10 address selected GS locations.
3. Erase RBS to blanks.
4. Restart 650.
5. Transfer information from card to RBS.

### Circuit Operation

To explain the complete read-in of information from card to general storage, the circuit action in response to a 70 operation code will be traced including the transfer from RBS to GS, erasure of RBS and the subsequent read-in of a specific digit from the card to its proper position in RBS.

Assume that calculation has been proceeding with the control commutator advancing through alternate I and D half cycles. On the last I half cycle an instruction containing a 70 code was transferred to the program register. Restart to D has occurred and, during the restart word interval, the 70 operation code and its accompanying D-address have been placed in the operation and address registers.

As the restart B latch goes off, read-punch D control is developed to test for the presence of a 70 or 71 code.

Since a 70 is present in the operation register, the code 70 latch is turned on. This latch remains on through its latchback circuit until read punch D control is removed by the next restart. While on,

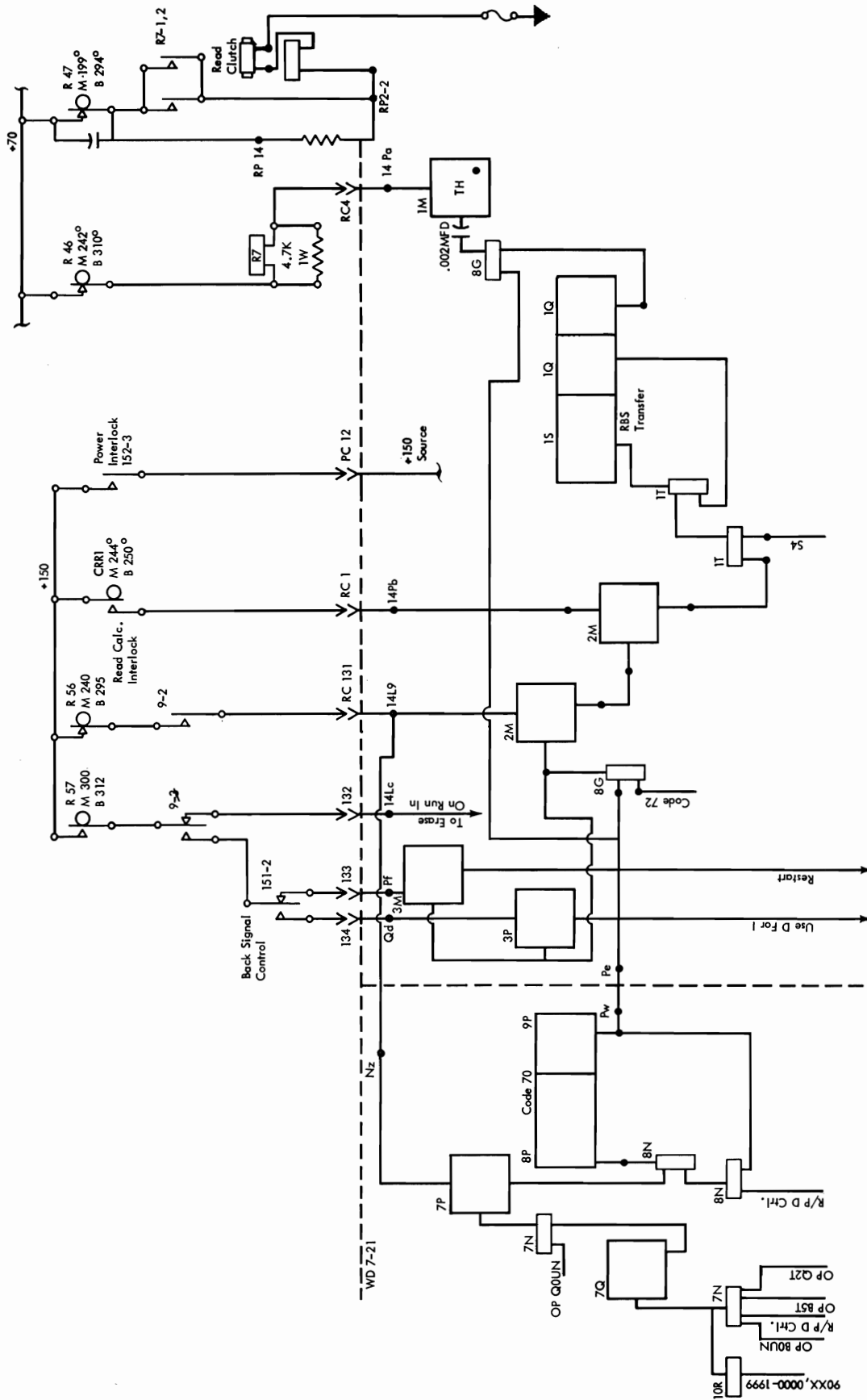

Figure VII-3. Read Feed Circuits



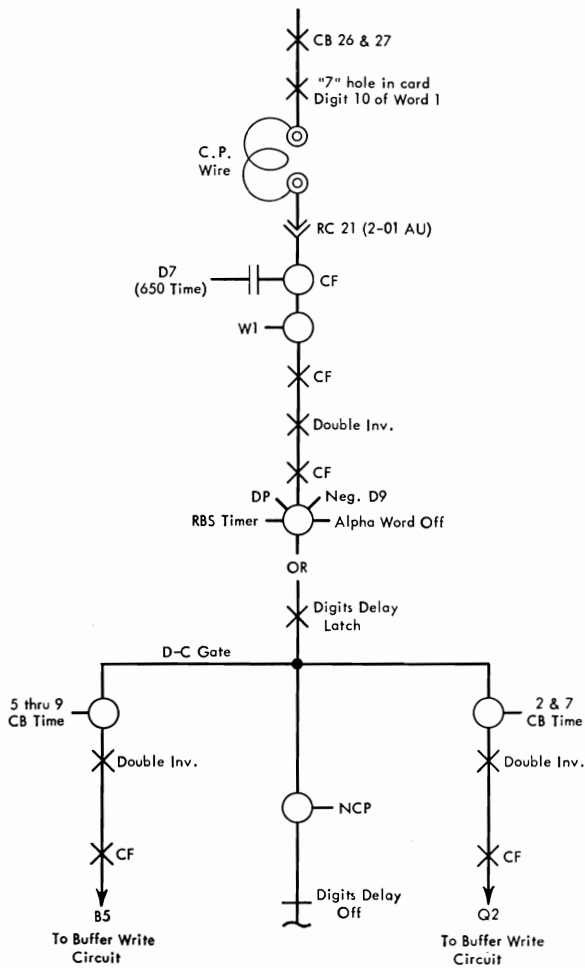

Figure VII-4. Scan a "7" Hole into Word 1, Digit 10 Position

it provides switching to start the read feed, turn on the RBS transfer latch, and restart the 650. The transfer latch gates the transfer from buffer storage to general storage and switches with S3 to turn on the erase latch which switches with the RBS timer output to provide a buffer-storage erase gate. This erase gate coincides with the time when the ten words of RBS are passing the buffer-storage read/write heads and gates a series of write sample pulses through to the buffer-storage erase windings of the seven buffer storage heads.

This results in placing a magnetic spot of *erase* polarity in each bit of each digit of all ten RBS words, leaving RBS erased to blanks. This erasure of RBS takes place on the next drum revolution following RBS to GS transfer, very early in the reader cycle.

Later in the reader cycle, during 12 through 9 CB time, new card information will enter RBS. Now, however, with transfer and erasure of RBS complete, a restart signal can be sent to continue calculation. At 300 degrees of the reader cycle when R cam 57 closes, anode voltage is applied to one or the other of two cathode followers at 9-3M and 9-3P (WD 3-30A) depending upon the status of R151, the back signal control relay.

The read code latch is still on and BS interlock was turned on at the start of the RBS to GS transfer operation. Thus, when R57 closes, either a restart or a use D signal is developed.

A restart turns on restart A and resets operation and address registers. Read-punch D control will be removed when restart B turns on. Use D removes read-punch D control. Thus, either signal (restart or use D) causes unlatching of the code 70 latch.

To explain entry of card information to RBS, assume a seven is punched in the digit ten position of word one. At seven time the impulse CB's apply anode voltage to the cathode follower at 14-1E (WD 2-01AU, Figure VII-4).

The CB's (R26 and 27) maintain this circuit for approximately 5.8 milliseconds. This includes more than one drum revolution so that all drum timing gates occur at least once while the CB's are made.

This seven is to be associated with the D10 position of the first word of storage. As previously explained, it must be recorded in RBS two digits early or at D8 time and thus must be scanned from the card three digits early or at D7 time.

### Code 71 — Punch Out to Card (Figures VII-5 to VII-8)

#### General Circuit Action

On a punch operation (code 71), PBS is erased to blanks, ten words of information are transferred to PBS from the W27-W36 positions of the general storage band specified by the D-address accompanying the code 71. This information in PBS is distributed to punch magnets by action of the punch thyatron matrix and associated circuits.

The BS transfer and erase control circuits are activated by a signal from the punch code latch when a 71 code is sensed. These circuits develop the

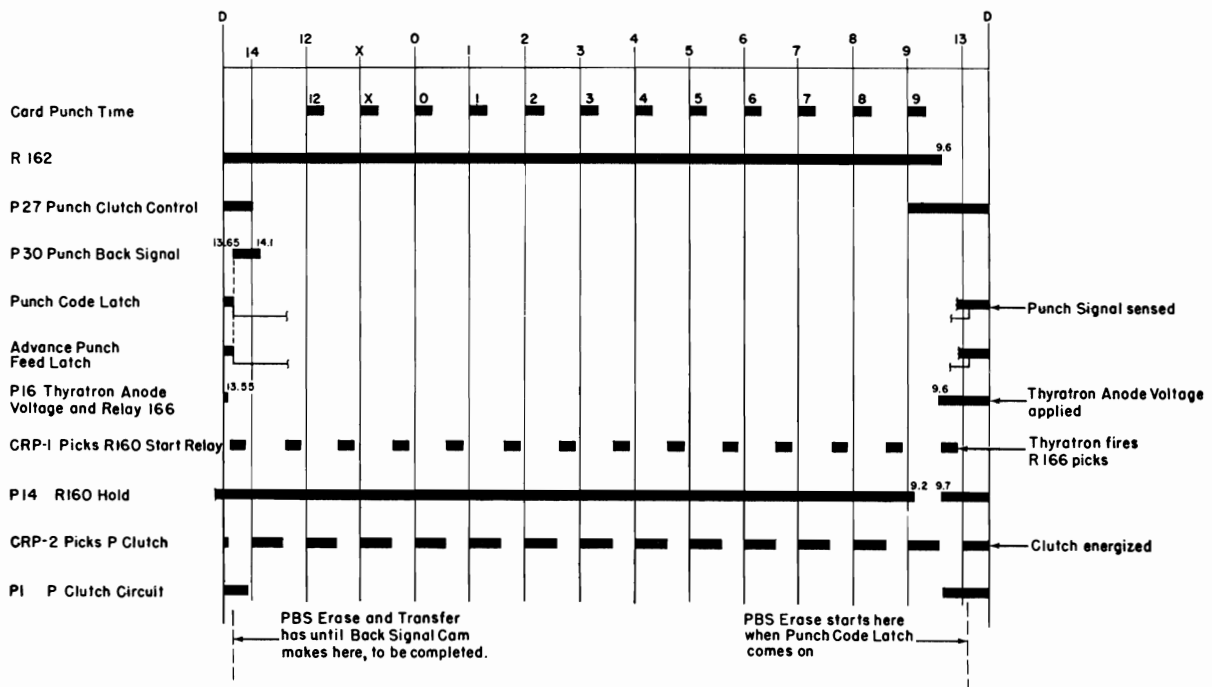
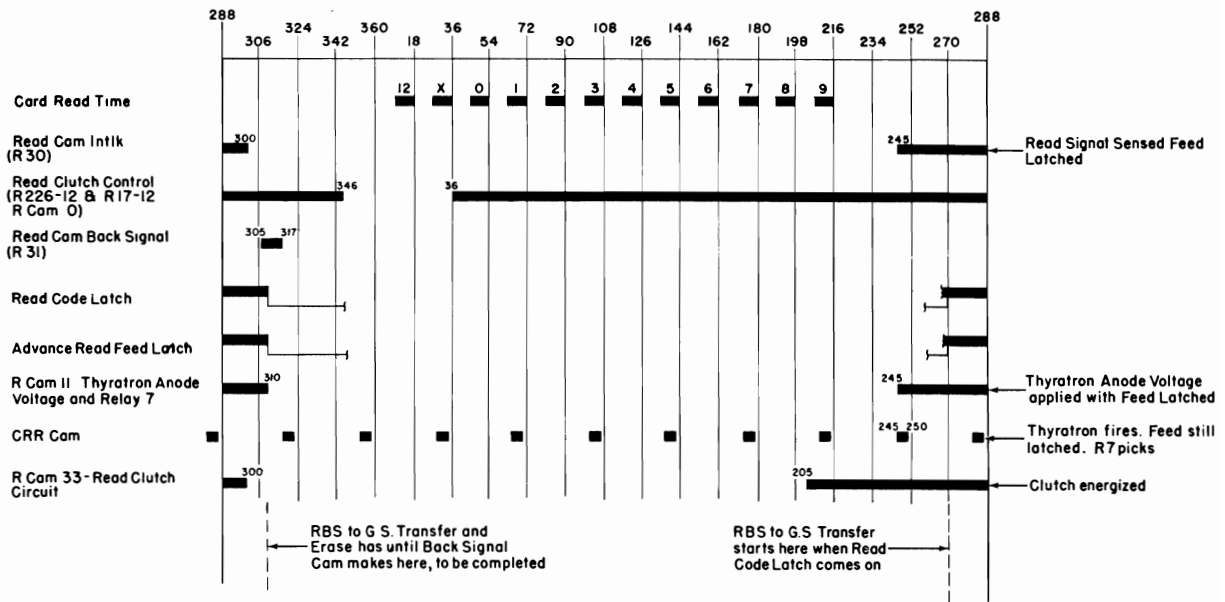

Figure VII-5. Read-and-Punch Feed Timing Charts

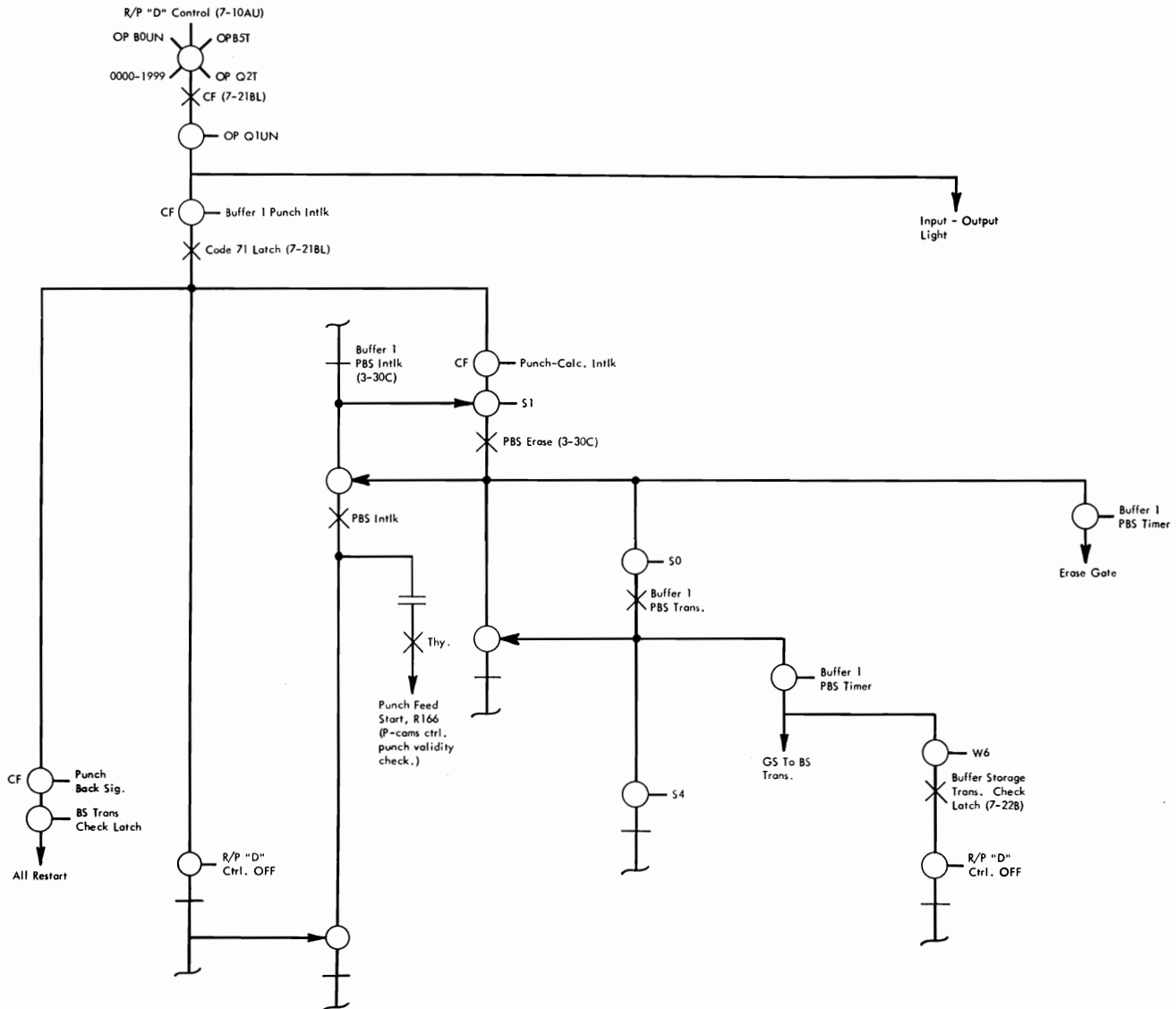

Figure VII-6. Punch—Code 71

BS erase gate and the RIPBS gate, resulting in the erasure of PBS to blanks and the transfer of the contents of W27-W36 of the selected general storage band to PBS. The erasure and the transfer occur on two successive drum revolutions at the start of the punch cycle, before card punching time.

The association of a specific digit of a specific word of PBS with a card column is accomplished by the matrix of 110 thyristors shown in WD 2-13. There is one thyristor for each digit position of each of the ten PBS words. Each thyristor is associated with a digit of a word by action of the digit and word timing gates which control its grids.

The PBS timer develops a gate from S2, W7, D0 to S3, W7, D0. This is the timed source of the RIPBS gate which allows on-time information from general storage to enter PBS. The PBS timer output also controls the time of development of the BS erase gate for PBS.

Major Objective:

Transfer data from 650 to a card in the punch.

Minor Objectives (Figure VII-6):

1. Erase PBS to blanks.
2. Initiate punch feed start.
3. Transfer from the 10 address selected GS locations to PBS.

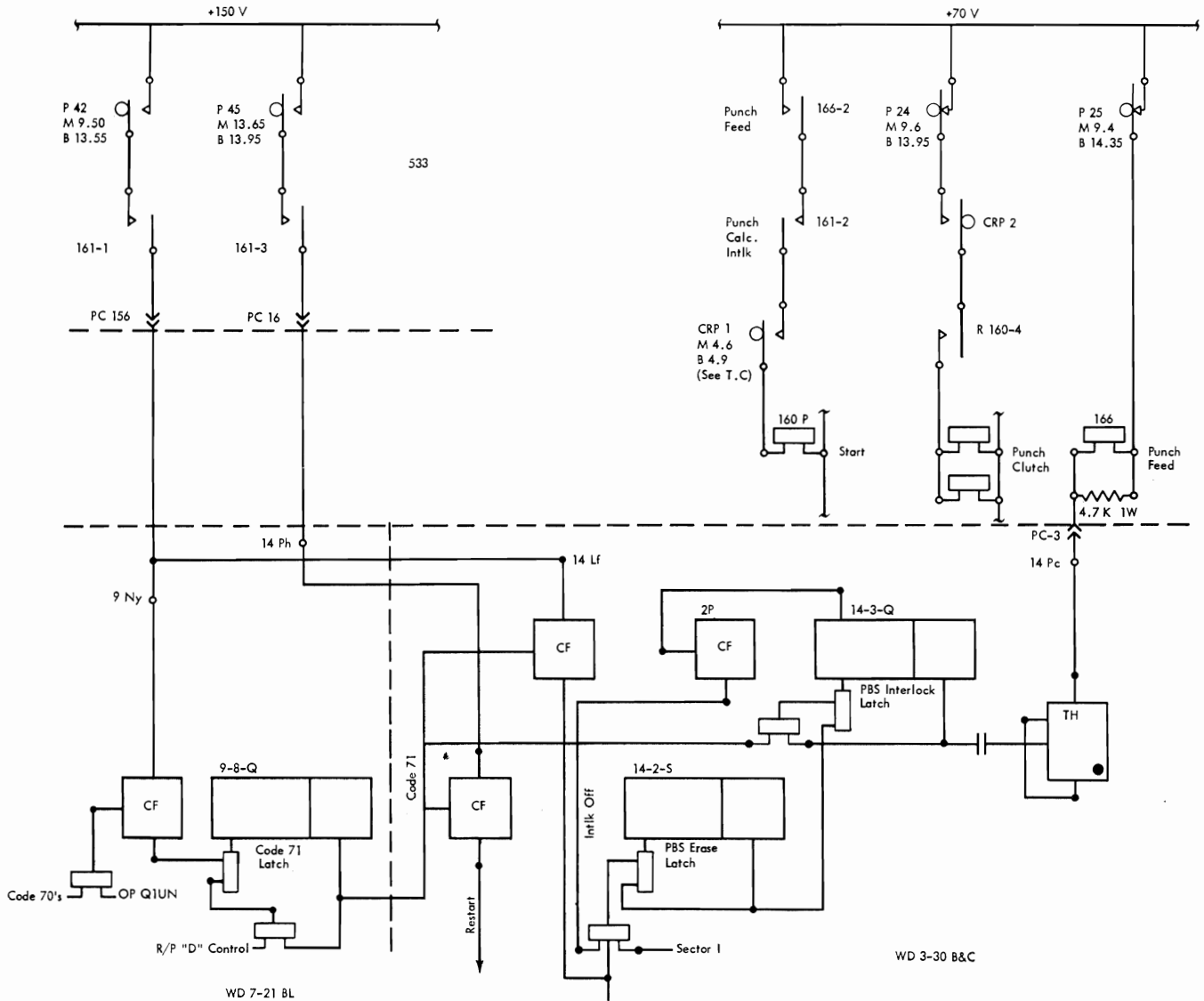

Figure VII-7. Punch Feed Circuit Composite

4. Restart 650.
5. Transfer information from PBS to card.  
See WD0-99 for data flow.

#### Circuit Operation

To explain the complete punch-out of information from general storage to card, the circuit action in response to a 71 operation code will be traced including erasure of PBS, transfer from general storage to PBS and the subsequent distribution of properly timed information impulses to punch magnets.

We will assume that calculation has been proceeding, with the control commutator advancing through alternate I and D half cycles. On the last I half cycle

an instruction containing a 71 code was transferred to the program register. Restart to D has occurred and, during the restart word interval, the 71 operation code and its accompanying D-address have been placed in the operation and address registers.

As the restart B latch goes off, read-punch D control is developed to test for the presence of a 70 or 71 code. Because a 71 is present in the operation register, the code 71 latch is turned on. This latch remains on through its latchback circuit until read-punch D control is removed by the next restart.

The code 71 latch output switches with buffer-storage interlock latch off output and the next S1 timing pulse to turn on the PBS erase latch.

This latch stays on through its direct latchback circuit until turned off at the next S0 timing pulse, when PBS transfer latch turns on. While on, this latch provides the PBS erase gate and mixes to turn on the buffer-storage interlock latch.

The PBS interlock latch activates the punch clutch thyatron circuit and starts a timed series of events resulting in energization of the punch clutch magnet at the proper mechanical time for the pawl to catch one of the clutch ratchet teeth. The code 71 latch output switches with buffer-storage interlock latch off output and the next S1 timing pulse to turn on the PBS erase latch.

The PBS erase latch switches with the PBS timer output to provide a buffer-storage erase gate. This erase gate coincides with the time when the ten words of PBS are passing the buffer-storage read-write heads and gates a series of write sample pulses through to the buffer-storage erase windings of the seven buffer-storage heads. This places a magnetic spot of erase polarity in each bit of each digit of the ten PBS words and leaves PBS erased to blanks. The PBS interlock latch allows the buffer-storage erase gate to be developed only once for any code 71 operation. This erasure of PBS occurs early in the punch cycle, possibly even before the clutch pawl has engaged a ratchet tooth.

The PBS transfer latch is turned on at S0, and stays on through a direct latch back circuit until turned off by the next S4 pulse. While on, it provides the general storage to buffer-storage transfer gate, which switches with the PBS timer output to provide the general storage to PBS transfer gate. This gate allows information from general storage (5 to 7) to enter buffer storage. The PBS interlock latch allows the GS to PBS transfer gate to be developed only once for any code 71 operation.

Note that the entire contents of the selected band of general storage have been available from the 5-to-7 circuits ever since the D-address entered the address register. The GS to PBS transfer gate allows only the information in W27-W36 to enter PBS. This transfer from general storage to punch buffer storage occurs on the next drum revolution after erasure of PBS, very early in the punch cycle.

Later in the punch cycle, during 12 through 9 CB time, the transferred information now in PBS will be distributed to punch magnets for entry into

the card. Now, however, with erasure and transfer to PBS complete, a restart signal can be sent to continue calculation. At 13.65 on the punch index, when P cam 45 closes, anode voltage is applied to the cathode follower at 14-5M and a 650 restart is developed.

This turns on restart A and resets the operation and address registers. Read-punch D control will be removed when restart B turns on. With read-punch D control removed, the code 71 latch will unlatch. Removal of the code 71 latch output also interrupts the latchback path of the PBS interlock latch, allowing it to turn off.

Bi-quinary information gates from the buffer-storage output latches are continuously applied to the grids of the bi-quinary cathode followers (WD 2-12AU). Anode voltage is applied to these cathode followers by emitters synchronized with the punch, with the result that the cathode followers respond only to bi-quinary zeros during zero CB time, ones during one time, etc.

The output of the cathode followers is switched to provide a single information gate at a digit and word time indicative of its position in PBS. This gate enters the thyatron matrix and because of its time of occurrence is able to energize only one thyatron. This thyatron associates the gate with a specific card column.

Note that one-digit-late timing pulses are used to drive the grids of the thyatrons in the matrix, the sign thyatrons being driven with a D1 gate, D1 thyatrons with a D2 gate, etc. This is necessary because the information in PBS is available for distribution one digit late.

To explain distribution of PBS information to the proper card column, assume that a seven is stored in the D10 position of the eighth word of PBS. This information will be available from the buffer storage B5 and Q2 output latches at DX time of a W5 timing interval (one digit late). At seven CB time anode voltage is applied to the B5 and Q2 cathode followers by the punch emitters and P44. Anode voltage is applied to all thyatrons by P25, P27, and P28 for about 5.35 teeth on the punch index. P29 and the RC circuitry are for arc suppression and may effectively extend the conducting time of the thyatrons from approximately 1 to 4 milliseconds depending on the number of thyatrons conducting.

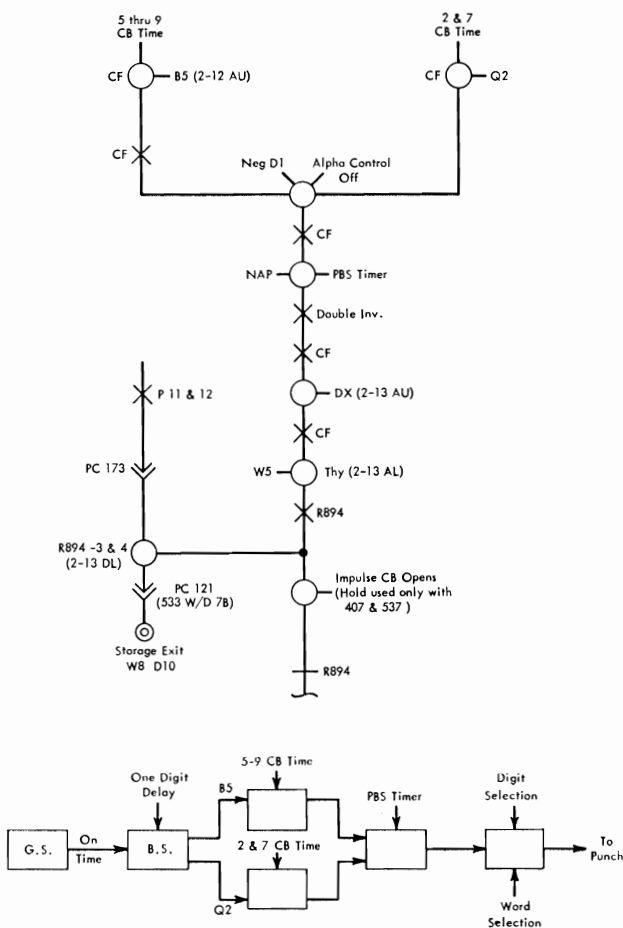

Figure VII-8. Punch "7" in W8, D10 from General Storage W34, D10

While this anode voltage is applied during the PBS timer interval, the B5 and Q2 cathode followers respond to the information from buffer storage and the output is a B-A gate during the W5 timing interval included in the PBS timer gate. This B-A gate switches with a DX timing gate and the resulting DX B-A gate drives the first grids of the thyatrons in the D10 column of the matrix. Only the thyatron in the W8 row will fire because it is the only one whose second grid is driven by a W5 timing gate. The relay wired to the thyatron (R894) will be energized until P28 breaks the thyatron anode circuit.

Notice that for each cycle point anode voltage is applied for about 5.35 teeth or at 100 cpm approximately 23 milliseconds. In this length of time the drum revolves about five times, and a thyatron has several chances to fire.

## SIGN READ-IN AND PUNCH-OUT

IN the 650 drum storage system plus signs are stored as nines, while minus signs are stored as eights. Thus, if a plus word is read into general storage a nine must be entered in the sign storage position (D0). If a minus word is read-in, an eight must be entered in the D0 position of the storage location. As with other information, if these D0 nines or eights are to be available from general storage at D0 time, they must be entered into RBS two digits early or at D10 time and scanned from the card three digits early or at D9 time.

When information is entered from non-load cards in the 650, the operator has a choice of using either a twelve punch for plus and an X for minus or blank for plus and X for minus. With either choice, the sign can be punched over the units position or in a separate column. Where information is entered from load cards, a plus sign must be identified by a twelve and a minus sign by an X and the sign indication must be punched over the units position.

### Sign Read-In (Figure VII-9)

The following list summarizes the various ways of handling sign entry.

Load Cards. Load hub wired.

Plus. Twelve punch over units position.

Minus. x-punch over units position.

No brush to storage entry wiring.

Read plus *not* wired.

Read sign over units *not* wired.

Read plus relays 30 and 33 are picked with load relays (533 WD 27A).

Non-Load Cards. Storage entry must be wired from brushes.

A. Plus twelve, Minus x—over units, read plus wired.

Read sign over units wired.

Storage entry sign *not* wired from brushes.

B. Plus twelve, minus x—not over units.

Read + wired.

RSU *not* wired.

Storage entry sign wired from brushes.

C. Plus blank, minus x—over units.

R + *not* wired.

RSU wired.

Storage entry sign *not* wired from brushes.

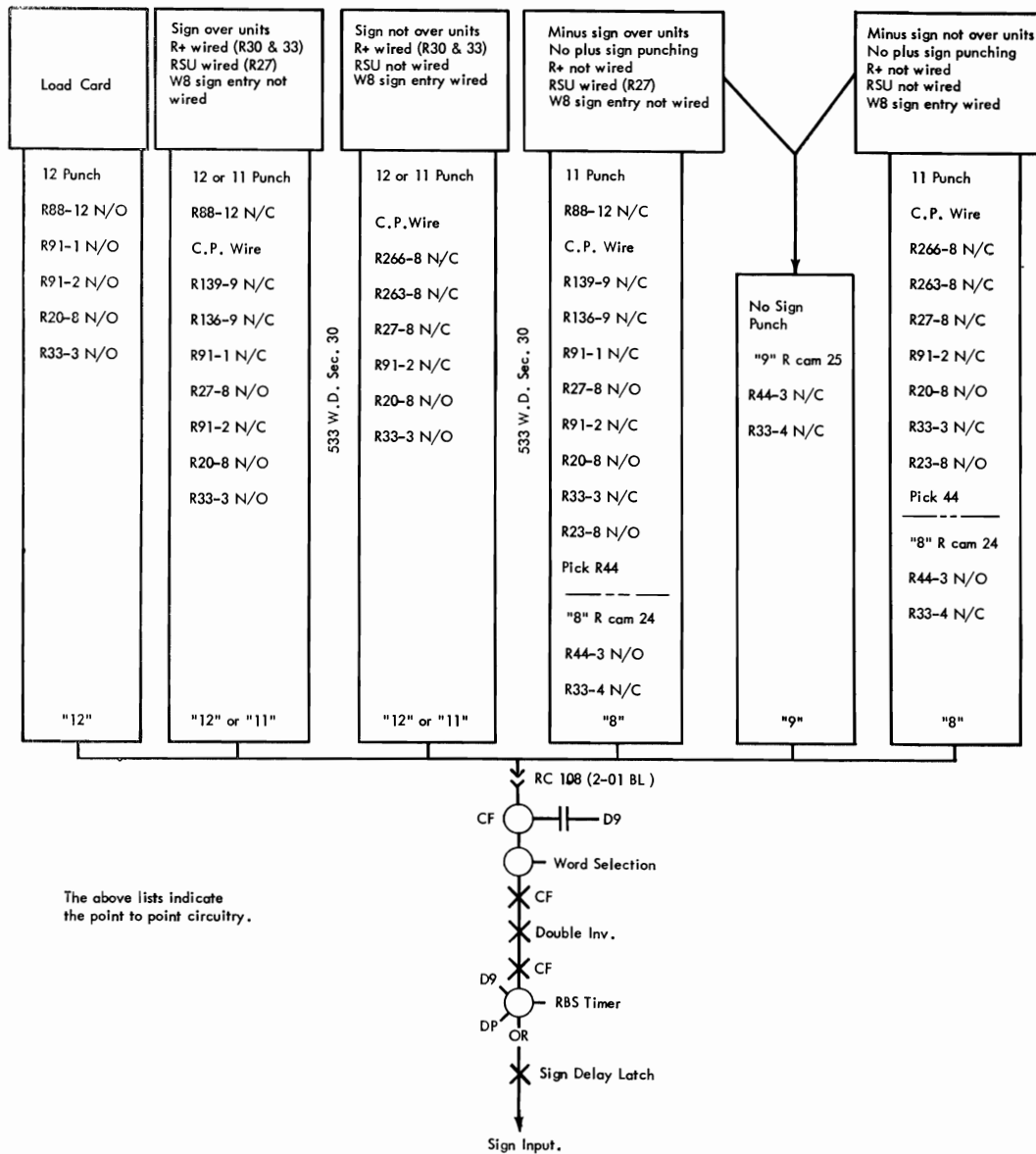

Figure VII-9. Sign Read-In to Word 8

D. Plus NX, minus X—not over units

R + not wired.  
RSU not wired.

Storage entry sign wired from brushes.

It has been explained that plus signs are stored as nines and minus signs as eights and that for these nines or eights to be available from general storage at D0 time they must be entered into RBS at D10 time (two digits early). Thus, the circuit objective on sign RI, regardless of which system of sign in-

dication is used, must be to supply bi-quinary nines or eights to the RBS entry switches at D10 time of each word.

It has already been seen how the scan delay latch responds to a three-digit-early digit gate and acts to provide two-digit-early information gates to RBS. It has also been explained that nines can be developed for transmission to RBS at nine CB time and eights at eight CB time.

The read emitters can also apply anode voltage to the B5 and Q4 cathode followers at twelve CB time and to the B5 and Q3 cathode followers at X CB time. Thus, nines and eights can be developed at twelve and X CB times, respectively, as well as at nine and eight CB times.

Sign nines can therefore enter RBS at either twelve or nine CB time and eights at either X or eight CB time. Both CB times are used for sign entry depending on which system of sign indication is used.

The sign cathode followers in the scan matrix are driven by D9 timing gates and put out D9 gates when anode voltage is applied by read brush action. These D9 gates are further associated with the proper drum word by switching, resulting in a D9, B-A sign input to the sign delay latch switching. The RBS timer and, a D pulse, are the other conditions necessary for turning on the sign delay latch. This switching prevents the sign delay latch from responding to any signals from the matrix other than D nines (sign), during twelve and X CB times.

The sensing of a sign indication in the card must result in the application of anode voltage to the associated matrix sign cathode follower. During the time that anode voltage is applied, sign nines or eights will be entered into the sign position of the associated RBS word.

### Sign Punch-Out (Figure VII-10)

On punch operations, sign nines and eights are available from general storage at D0 time for entry into PBS and are, therefore, available from PBS at D1 time. Thus, a D1 nine from PBS must be capable of causing a twelve to be punched in the card, while a D1 eight must cause an X to be punched. It must be possible, however, to prevent punching of a twelve by a D1 nine when the blank-X system of sign indication is used. On punch operations, whether the twelve-X or blank-X system is used, the sign indication can either be punched over the units position or in a separate column.

### Word Size Emitter (Figure VII-11)

On some applications it may be required to enter words of less than ten digits. When this is done, zeros must be entered in those storage positions following the highest significant digit to avoid blanks in general storage and subsequent validity checking errors.

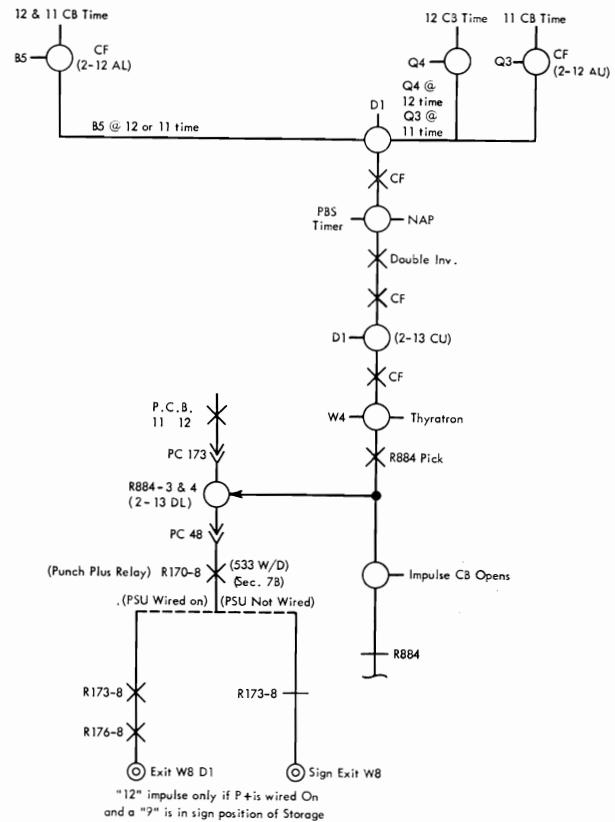

Figure VII-10. Sign Punch-Out—Word 8

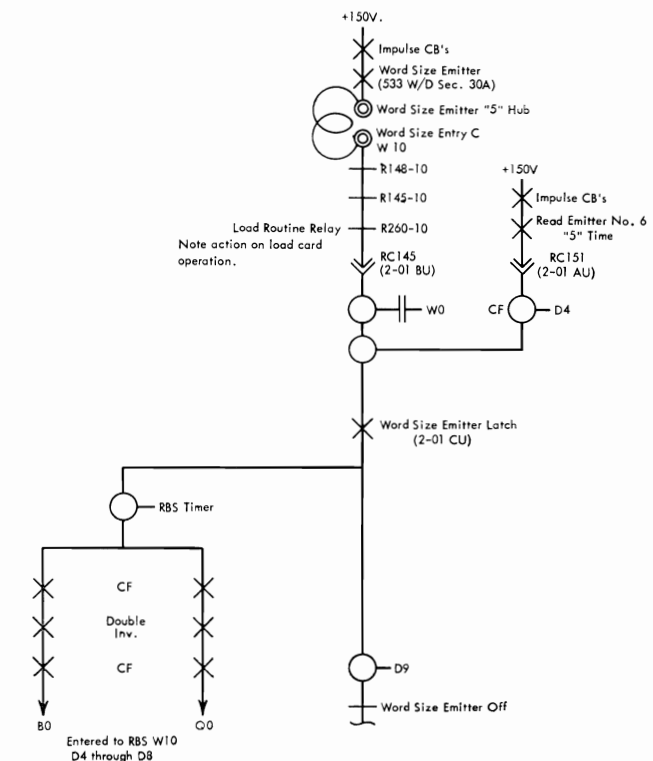

Figure VII-11. Word Size Emitter (Word Size of 5 in Word 10)



The word size circuits are provided to allow automatic insertion of zeros into all storage digit positions beyond the one specified. Word size is wired on the 533 control panel. Word size emitter hubs are provided, one for each possible size from 0 through 10. Word size entry hubs for entry A, B, and C for each word (1 through 10) are provided. On load card operations the word size circuits provide an automatic word size of 10 for words one through eight and a word size of 0 for words 9 and 10.

Information must be presented to RBS two digits early. Thus, if word size zero is used, requiring zeros to be entered in digit positions 1 through 10 of an RBS word, the word size latch must be on from the beginning of DX through D8. If word size five is used requiring the entry of zeros in digit positions 6 through 10, the latch must be on from the beginning of D4 through D8. The word size emitter hubs emit the proper two-digit-early gate to control the turning on of the word size latch at the proper time.

Note word size ten emitter hub ties back to -50 volts. All word size entry hubs not wired from some other emitter hub should be wired from word size ten. This is necessary to prevent an input to one of the diode coincidence switches from *floating* and allowing the word size latch to turn on with the leading edge of the word gate on the other input.

#### Major Objective:

Enter zeros into unused high-order positions of read buffer storage data words on a read-in operation.

#### Minor Objectives:

Turn on word size emitter latch at the proper time to provide B0 Q0 pulses to read buffer storage input for the indicated number of digit times.

#### Circuit Operation

The word size circuits are shown in WD 2-01AU. The circuit objective is to raise the B0 and Q0 output lines for that remaining portion of the word interval following the entry of the last punched digit from the card field. This will result in the entry of zeros into those digit positions of the RBS word which would otherwise remain blank for lack of card information. The B0 and Q0 output lines will be raised whenever the word size latch is on. Switch circuits are provided which control the turning on of the word size latch at a digit time determined by the control panel wiring. The latch is turned off by the next D9 gate.

If we assume that word 10 on the card will require a maximum of five digits and a 5-column field is therefore provided, the word size emitter five hub is wired to one of the W10 word size entry hubs A, B or C (usually C unless entry A or B is wired). In this case when less than five significant digits appear in card W3, the five-digit field must be completed with punched zeros.

This wiring will result in the insertion of zeros into the D6 through D10 positions of the third word of RBS on all read operations thus providing a ten-digit word for transfer to general storage.

# SECTION VIII. ALPHABETIC DEVICE

THE purpose of the alphabetic device is to transfer alphabetic information from the input device to the output device.

## Description

The alphabetic device provides a maximum input and output of 30 alphabetic characters distributed

in the first six storage entry or storage exit words. Typical 533 control panel wiring is shown in Figure VIII-1 for read-in and in Figure VIII-2 for punch-out. The alphabetic device is available in three different options.

1. Alphabetic only.
2. Alphabetic with special character 11 and 12 only.

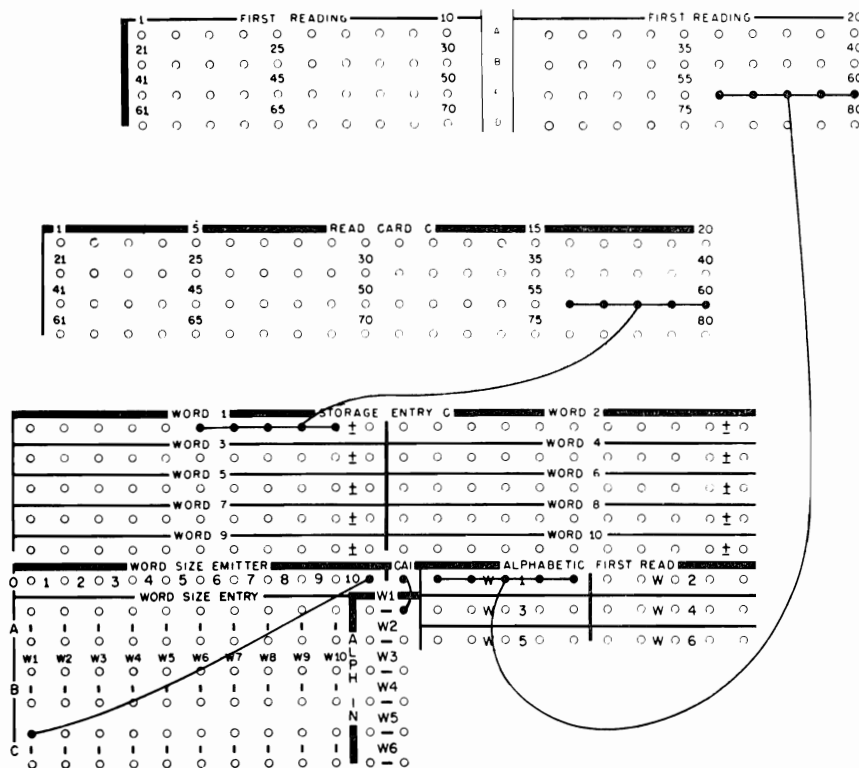

Figure VIII-1. Alphabetic Read-In Wiring

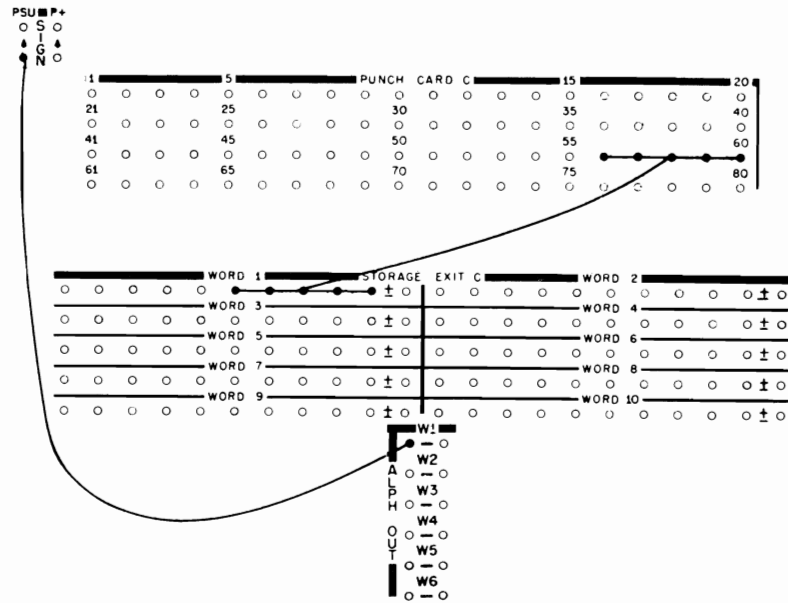

Figure VIII-2. Alphabetic Punch-Out Wiring

3. Alphabetic with all special characters. This option will handle all characters shown in Figure VIII-3.

Each position in an alphabetic word is coded as a two-digit number (Figure VIII-3), so that the standard 650 circuits can be used. The five alphabetic positions require ten digits for coding. Figure VIII-4 indicates the method of coding.

### Alphamerical Input

Identification of an alphabetic word is accomplished by control panel wiring from the control alphabetic information (CAI) hub to the alpha. in hub of the word which is to be alphabetic. This accomplishes the following:

1. Shift the storage input from the brushes to the correct digit positions of RBS.
2. Provide a word gate to make the designated word function as an alphabetic word in the 650.

At the first read brushes, each position in an alphabetic word is analyzed to determine whether it is numerical, alphabetic, special character, or blank. Then this information is transferred to the 655, where it is stored in relays for the next card feed read cycle.

At the second read brushes, the card punching is scanned to develop the bi-quinary values. This is accomplished in the following manner. The resulting output of the input-scan matrix is switched with the information retained in the storage relays, with alpha word, and proper digit timing, to turn on the proper information delay latch. The numerical information delay latch is turned on for a numerical character or a blank position, the alphabetic information delay latch for an alphabetic character, and the special character information delay latch for a special character.

NOTE: An information delay latch (2-32 AU) is substituted for the digits delay latch (2-01 CL), which is used for numerical words.

		ZONE PUNCHING			
		12	11	0	No Zone
		Char	Char	Char	Char
		Code	Code	Code	Code
NUMERIC PUNCHING	1	A 61	J 71	/ 31	1 91
	2	B 62	K 72	S 82	2 92
	3	C 63	L 73	T 83	3 93
	4	D 64	M 74	U 84	4 94
	5	E 65	N 75	V 85	5 95
	6	F 66	O 76	W 86	6 96
	7	G 67	P 77	X 87	7 97
	8	H 68	Q 78	Y 88	8 98
	9	I 69	R 79	Z 89	9 99
	8-3	. 18	\$ 28	, 38	# 48
8-4	□ 19	* 29	% 39	@ 49	
None	& 20	- 30		Blank 00	
0				0 90	

Figure VIII-3. Alphabetic Symbol Code Chart

In order to code the alphabetic character as a two-digit number, the output of the designated information delay latch is switched with an alpha. units digit gate. The resulting output is then switched with the index timings of the input device to develop the bi-quinary bits of the units digit. The tens digit is developed from the alpha. tens gate in a similar manner. These bi-quinary values are read into RBS in the normal manner.

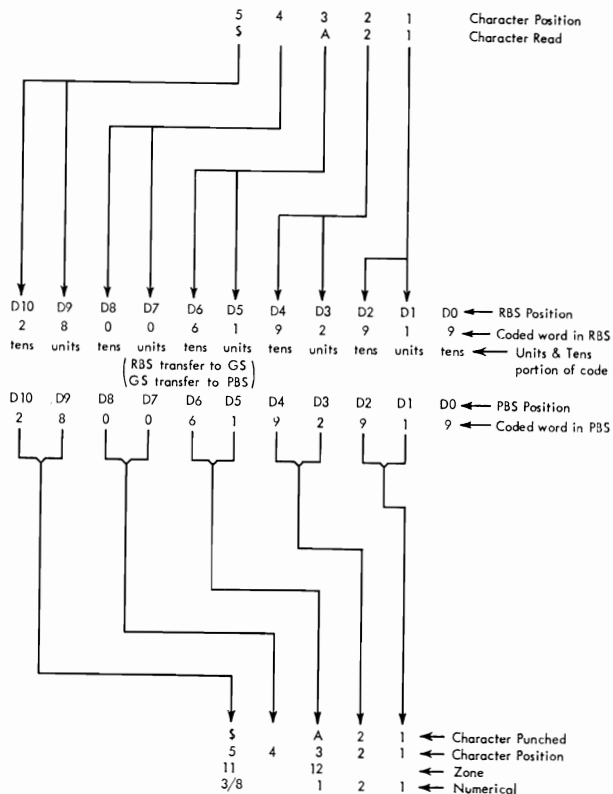

Figure VIII-4. Method of Alphabetic Coding

**Major Objective (Alphamerical Input)**

Read the alphamerical word into RBS as a coded ten-digit number.

**Minor Objectives:**

(The example given is storing a dollar sign [\$], code 28. Assume that the \$ is in the fifth-character position of alphabetic word 1. The dollar sign is represented by 11, 3, and 8 punches in the card.)

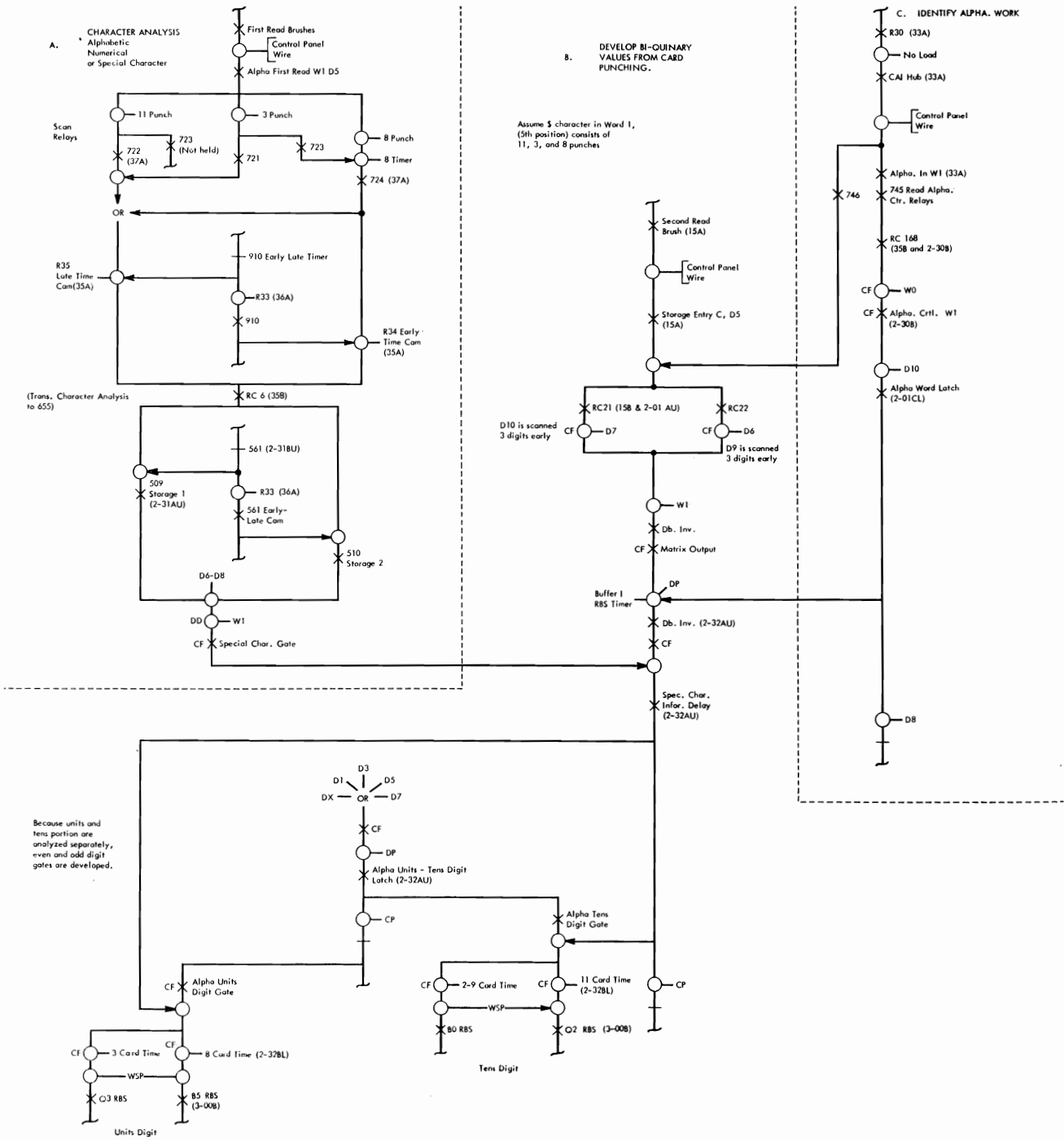

Figure VIII-5. Alphabetic Read-In Function Chart

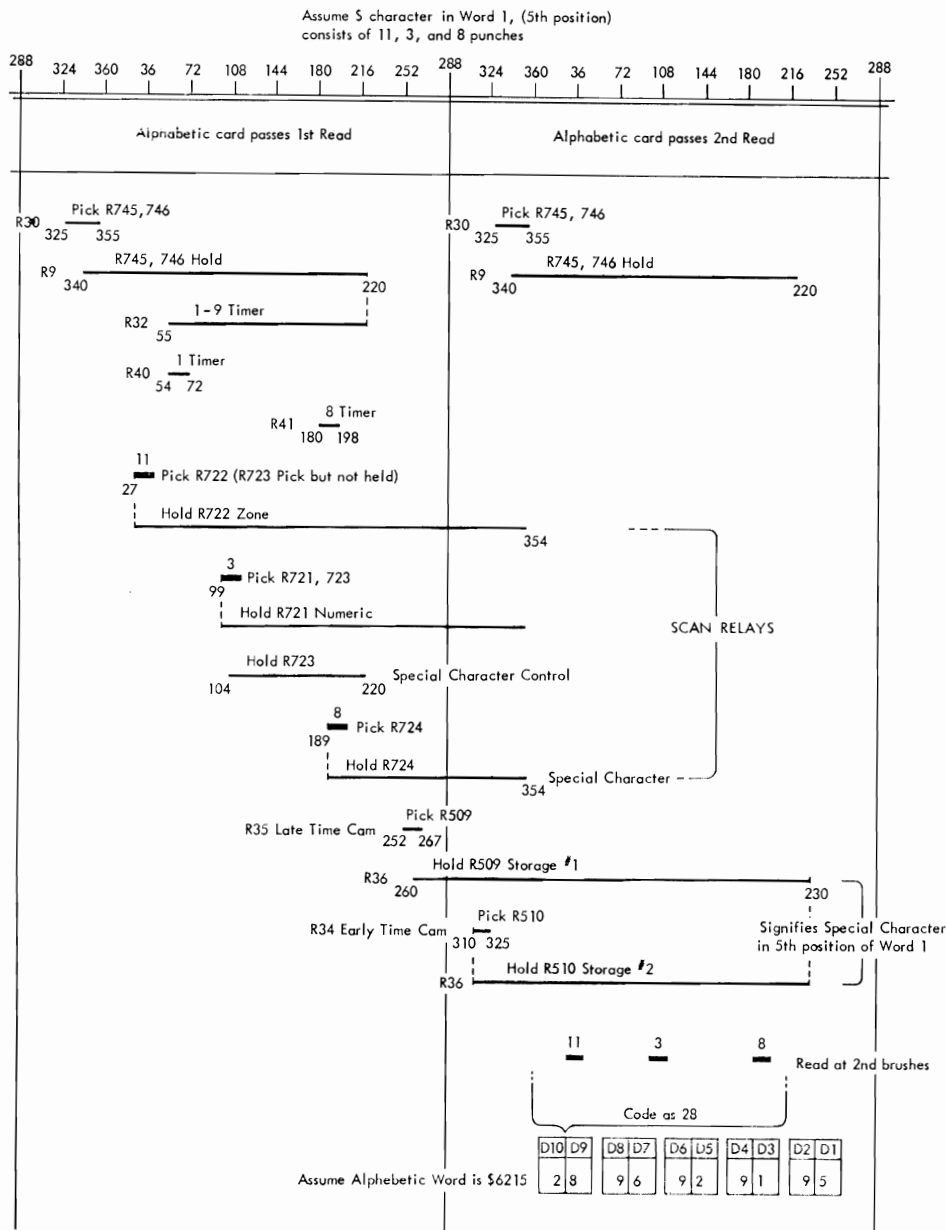

Figure VIII-6. Alphabetic Circuits Sequence Chart

1. Identification of an alphabetic word (Figure VIII-5C).

a. Control panel wiring.

- (1) CAI hub wired to ALPHA. IN W1 hub.
- (2) Shift storage input from brushes (R746 points on the 533 WD, sections 15, 16)
- (3) Develop an alphabetic word gate
  - (a) Alpha. word latch

2. Character analysis (Figure VIII-5A)

a. First read brushes wired to ALPHA. FIRST READ.

b. Store information in 655 for use as card is read at the second read brushes.

(1) Storage 1 and storage 2 (relays).

NOTE: The early-late timer is used so that one wire can be used in the cable for each alphabetic character instead of two. This saves a total of 30 wires in the cable between the 533 and 655.

3. Develop bi-quinary values (Figure VIII-5 B).

- a. Scan card from second read brushes
- b. Turn on special character information delay latch
- c. Analyzed units and tens portion of the code
  - (1) Even and odd digit gates

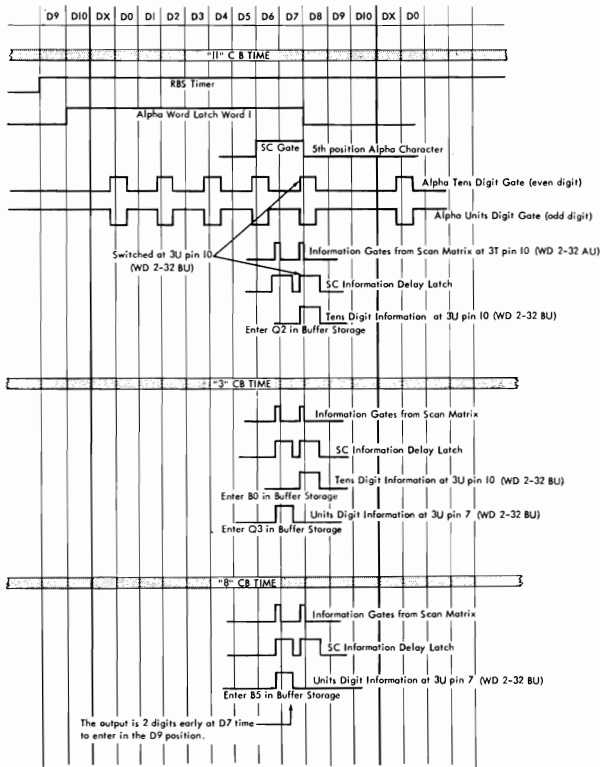

Figure VIII-7. Alphabetic Read-In Timing Chart

d. Bring up the proper bi-quinary values

(1) Read-in RBS

Refer to Figure VIII-6 and VIII-7 for timings.

Blank Position

Objective: Develop code 00.

A circuit from R38 (26A) is substituted for the second read brushes, because no scan relays are picked for the blank position at the first read brushes. Assume a blank position in word 1 alphabetic position 5. A circuit is completed through R38 (26A), R722-4 N/C (15B), 721-4 N/C, and 901-4 N/O. The remaining circuitry is similar to the circuitry described for the dollar sign.

Sign Operation

Objective: Develop B5 and Q4 for D0.

The plus sign associated with the alphabetic word 1 is provided by a 9 time pulse from R25 in the 533 (section 27A) to R746-2 N/O (16B). The +55-volt potential is brought to the plate of the cathode follower at 11E on WD 2-01 BU. The D9 time output of the cathode follower is scanned by the switch 4G (WD 2-01 CL). The output of 4G turns on the sign delay latch. The output of the sign delay latch

develops a B5 and Q4 at 9 reader time at cathode followers 4K pin 8 and 4L pin 8 respectively.

Alphamerical Output

Major Objective:

To cause the proper double punching in the card columns, from the alphabetic information stored in a PBS word.

Minor Objectives:

(Assume that a \$ is in buffer I PBS, word 1, D9 and D10. Figure VIII-8 concerns punching the 11. Figure VIII-9 concerns punching the 11, 3, and 8.)

1. Identification of an alphabetic word (Figure VIII-8A)

a. Control panel wiring (Figure VIII-2)

(1) PSU wired to Alph. Out. W1

Assume a 28 (\$) is stored in D9 and D10 of PBS, the 5th character position of Alphabetic Word one. Code 28 causes punching of 11, 3 and 8.

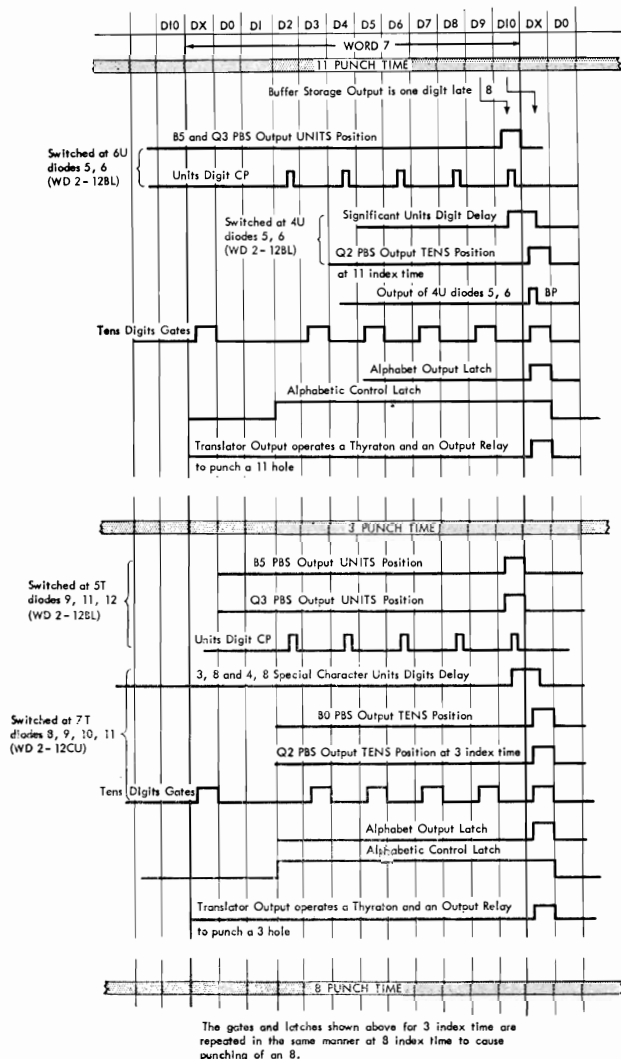

Figure VIII-9. Alphabetic Punch-Out Timing Chart

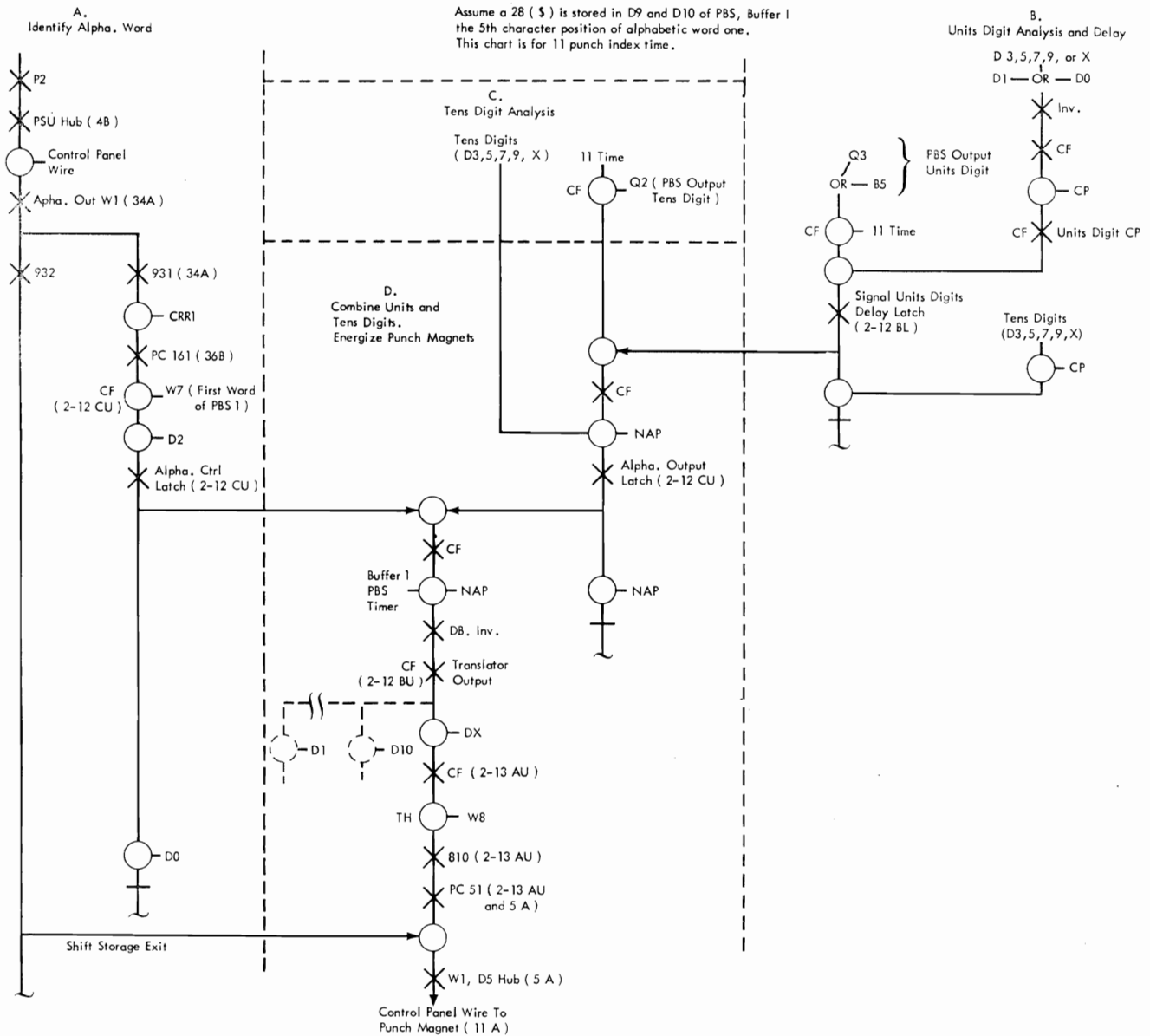

Figure VIII-8. Alphabetic Punch-Out Function Chart

- (2) Shift the storage exit pulses to punch the five alphabetic characters in adjacent columns (Section 5A and 6A of 533 WD)
- (3) Develop an alphabetic word gate
  - (a) Alphabet Control Latch
2. Units digit analysis (Figures VIII-8B and VIII-9)
  - a. Compare PBS output and punch index times
    - (1) Analyzed at D2, 4, 6, 8 and D10 time
    - b. Store the results of the units digit analysis for one digit time, so that the results may be switched with the tens digit.
      - (1) Turn on one of the four units delay latches (2-12BL) at the proper punch index time.
  3. Tens digit analysis (Figures VIII-8C and VIII-9)
    - a. Compare PBS output and punch index times
      - (1) Analyzed at D3, 5, 7, 9 and DX times.
  4. Energize punch magnet (Figures VIII-8D and VIII-9)
    - a. Compare units digit (stored in units delay latch) with the tens digit.
    - b. Turn on alphabet output latch
    - c. Translator output
    - d. Control panel (Figure VIII-2)



## SECTION IX. MAIN POWER SUPPLY

### INTRODUCTION TO THE ACME SINGLE- AND THREE-PHASE POWER SUPPLY

THE 655 houses, in addition to the read-in and read-out circuitry, the power supplies for all electronic circuits. The following list shows the power supplied and the units and purpose for which supplied.

- |                                     |   |
|-------------------------------------|---|
| 1. Unregulated voltage              | Blower motors   |
| 2. 24 volts ac                      | Buffer interlock relays                                     |
| 3. 230 volts unregulated            | Drum motor  |
| 4. Unregulated voltage, 10 amperes  | Buffers I, II, III  |
| 5. 115 volts at 10 amperes—isolated | Test equipment outlet                                       |
| 6. Filament bring-up voltage        | Filaments warm-up   |
| 7. Filament full voltage            | Filaments running   |
| 8. Negative 63 volts                | Protective bias (insures no accidental writing on the drum) |
| 9. Negative voltages                | Electronic circuits   |
| 10. Positive voltages               | Electronic circuits   |
| 11. 42 volts dc                     | Control relays and lights                                   |

A set of push-button control switches located on the relay gate performs the same functions as the power switches on the console of the calculator. Indicator lights labeled **POWER ON** and **READY** indicate the power status of the machine. Control is by means of contactors (power-operated switches) and relays.

### Application

The three-phase 655 power supply may be operated from either a one- or a three-phase line source. When used on three-phase lines, the unit does not use three-phase power as such. The various loads are distributed to the phases arbitrarily. The unit may be changed for operation on alternate source of power (from one to three or three to one phase) by changing the power cord and CB2 and rearranging the leads at the phase-changing terminal board to the right of the CB2. A bill of material is available for either change. Instructions for changing the leads for alternate source are given in the power supply circuit diagram 2-20A.

Operation may be from a 208 or 230 volts line source, plus or minus ten per cent. Adjustment for the different voltages is by means of jumpers on three sets of terminals at the base of the fuse panel and the input lines to the filament transformers on the opposite side of the machine. The jumpers and terminals on the fuse panel are provided for adjusting the voltages to the drum motor, test receptacle, and the control relays and lights. The stabilizing transformers for the dc supplies have taps for two ranges of input voltage (170-220 and 200-250). The line frequency will be specified in the wiring diagram of each machine. The frame must be at ground potential.

### Regulator

The power supply makes use of stabilizing transformers (Figure IX-1A) for the purpose of maintaining good voltage regulation. It is specially

constructed with a capacitor connected across the auto-transformer primary winding. This is the capacitive C section, which is designed to resonate at the power line frequency. The high current flow in the resonant winding provides a magnetic field that saturates this section.

To maintain the resonant condition, variations in the line voltage must be isolated from the resonant circuit. An inductor (L section), which operates well below saturation, is connected in series with the resonant circuit to absorb any line voltage variations.

This phenomenon is explained as follows: An inductor operating below saturation reflects a change in magnetic flux density proportional to the current change. Because the voltage developed across the terminals of an inductor is proportional to rate of change in its magnetic flux density, the voltage developed across the terminals of a non-saturated inductor will vary with any current change. Conversely, an inductor operating at saturation maintains a nearly constant magnetic flux density through a wide variation in current flow. Hence, a nearly constant voltage can be maintained across its terminals through a wide variation in current flow.

Voltage stability is accomplished in this manner. When the line voltage increases, a greater proportion of the line voltage will be dropped across the L section. When the line voltage decreases, a smaller proportion will be dropped across the L section. In either case the effect will be to maintain approximately a constant voltage across the C section.

The slight voltage variations across the C section may be further refined by adding a compensating-winding to the circuit (Figure IX-1B). It is coupled magnetically with the L section, and connected electrically, series opposing, to the secondary winding of the C section. The circuit is designed so that the voltage change developed by the compensating-winding is as near as possible to the change in voltage developed by the C section. Because the two variations are out of phase, the result is a more constant output voltage.

**CAUTION:** Beware of high voltage. The voltage developed across the full C section is much higher than the line voltage. Because the potential across this circuit may reach 850 volts use extreme care when servicing this part of the equipment.

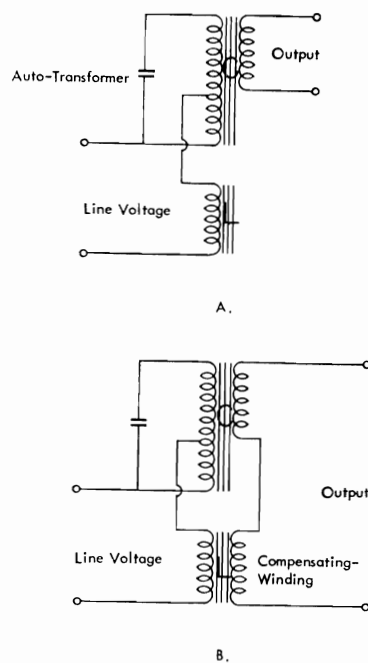

Figure IX-1. Stabilizing Transformers

### Metering

Two meters on the panel are provided for measuring the various voltages. The voltages to be measured are selected by means of three selector switches. A switch is provided for selecting the ac voltages. A second switch is provided for selecting the dc voltages to be measured. A position is provided (V6) on the dc switch to enable reading of the relay supplies on buffers I, II, III. Selection of the buffer voltage to be measured is by means of a third switch.

The dc voltages are measured by means of a 200-ohms-per-volt meter having two voltage ranges. The ranges are 0-150 and 0-300 volts. The accuracy is two per cent of full-scale value.

The filament and line voltages are measured by means of an iron vane-type meter having a 0-10 volts' range. The line voltage measurement is made possible by use of a potential transformer giving a range of 0-250 volts. The accuracy of this meter is also two per cent of full-scale value.

Voltages of distorted wave form will result due to regulation. The iron vane-type meter is used because it gives a more accurate reading of voltages other than sine wave. Remember, when servicing the equipment, that the D'Arsonal type meter will not give a true representation of non-sinusoidal ac voltages and should not be relied upon.

## Servicing

The power supply is so constructed that the various units are readily removed from the frame for servicing. The units are wired so that all interconnecting wires are brought to terminal boards for ease of removal.

All circuits (ac and dc) are fused or otherwise protected for current overloads. The dc branch circuits are fused by indicator-type fuses. All fuses are readily accessible for inspection and replacement.

## INTERLOCKING

The individual power supplies are interlocked so that a definite sequence of turn-on and turn-off occurs. This is done to protect the equipment from possible damage due to application of voltages or due to heat accumulation. In addition, the 655 power supply is interlocked with the 652 and 653 power supplies, which operate as slave units to the 655 power supply. The corresponding units in the 652 and 653 must be operated to complete the sequence. The interlocking circuits provide for indication of filament voltage at the 652 and 653, all negative voltages on at the 652 and 653, all plus voltages on at the 652 and 653. Interlocking is also provided for blower motor failures, filament failures, blown dc fuses, and blown ac fuses. The power supply may be operated independently of the 652 and 653 by installing a set of jumpers at a terminal board supplied for this purpose (00-34 CL, Note XII).

### Power-On Interlocking

When power is first applied, the blowers will be put into motion to start forced-air circulation. The voltages will be applied in such a sequence as to prevent damage to any of the components. The tube filaments will be brought up to operating temperature over a period of about one minute. The voltage is applied in such a manner as to prevent exceeding the current ratings by more than 25 per cent. When the filaments have reached operating temperature, the negative dc supplies will be turned on before the positive dc supplies.

The interlocking circuits assure that the supplies be turned on in proper sequence. The order of application of power is as follows:

1. Blowers  
– 63 volts
2. Filament bring-up circuit  
Drum motor  
Buffers I, II, III
3. Full filament
4. Negative voltage supplies
5. Positive voltage supplies
6. Ready light

When all the supplies in the 650, 652, and 653 have been turned on and the ready light on the console is on, the machine is in operating condition and ready to accept instructions.

Figure IX-2 shows the sequence of operations when the machine POWER-ON key is depressed. The chart shows the depression of the POWER-ON key resulting in the pick of relay 12, which in turn picks relay 4. Actually relay 4 is picked only if relay 31 (blown fuse) has *not* been picked and latched (00-34 AL). Relays 10 and 11 are shown as being picked by 16, 17, and 23. Actually, this circuit is further conditioned by filament ON relays in both the 652 and 653 (00-34 AL). Thus, before the negative dc voltage will be turned on, the filament voltage must be turned on in the 650, 652, and 653. In the same manner, R3 is conditioned by negative supplies in the 652 and 653, and the ready light is conditioned by the positive supplies in the 652 and 653. When circuit failures are being analyzed, it is suggested that the charts be used for locating the general area of failure and the logics be used in finding the actual trouble.

### Power-Off Sequence

The interlocking circuits provide for the removal of power in such manner as to prevent damage to the circuit components (Figure IX-3).

In general, the order of removal is as follows:

1. Positive dc voltage
2. Negative dc voltage
3. Drum motor
4. Filaments
5. Blower motors and protective bias

The blowers are left on for about five minutes after shut-down to prevent heat build-up in the units.

A POWER-OFF sequence may be initiated in several ways. (See hold circuit for relay 6 in 00-34 AL.)

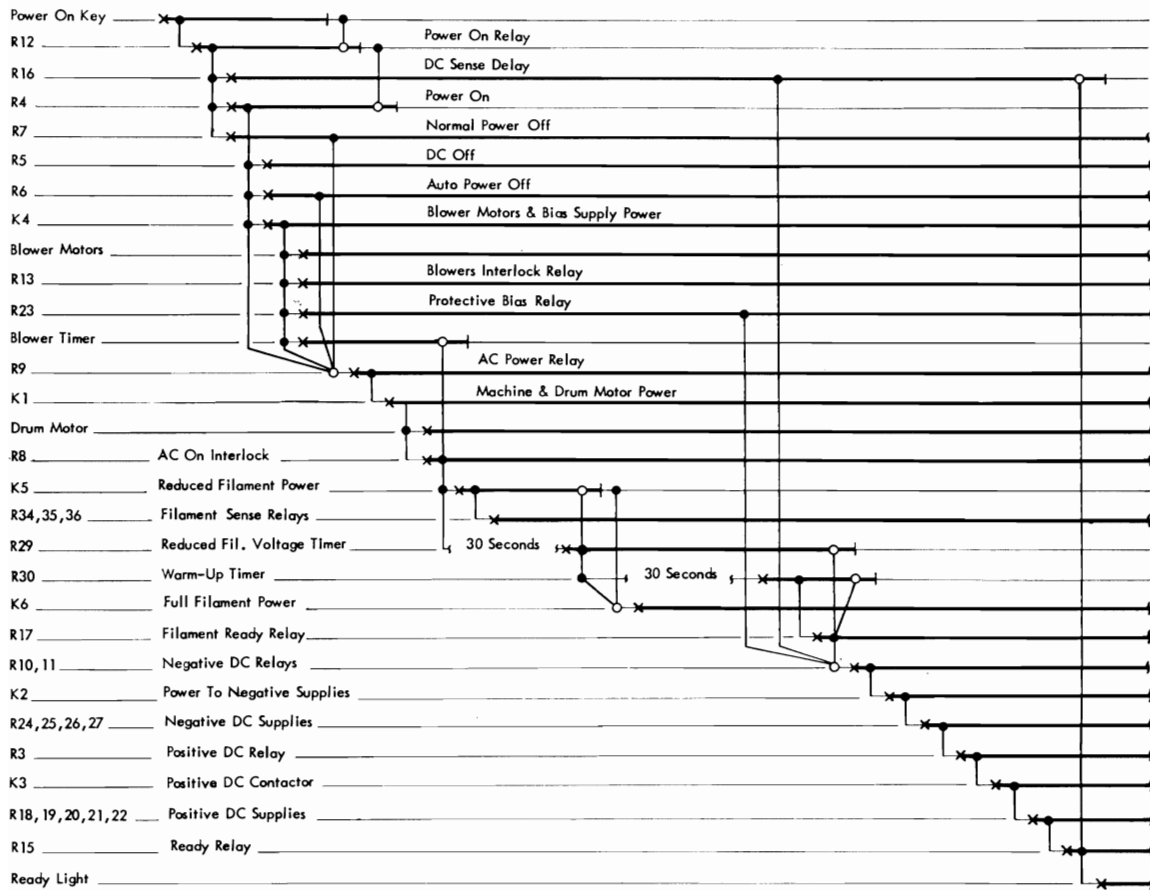

Figure IX-2. Power-On Sequence

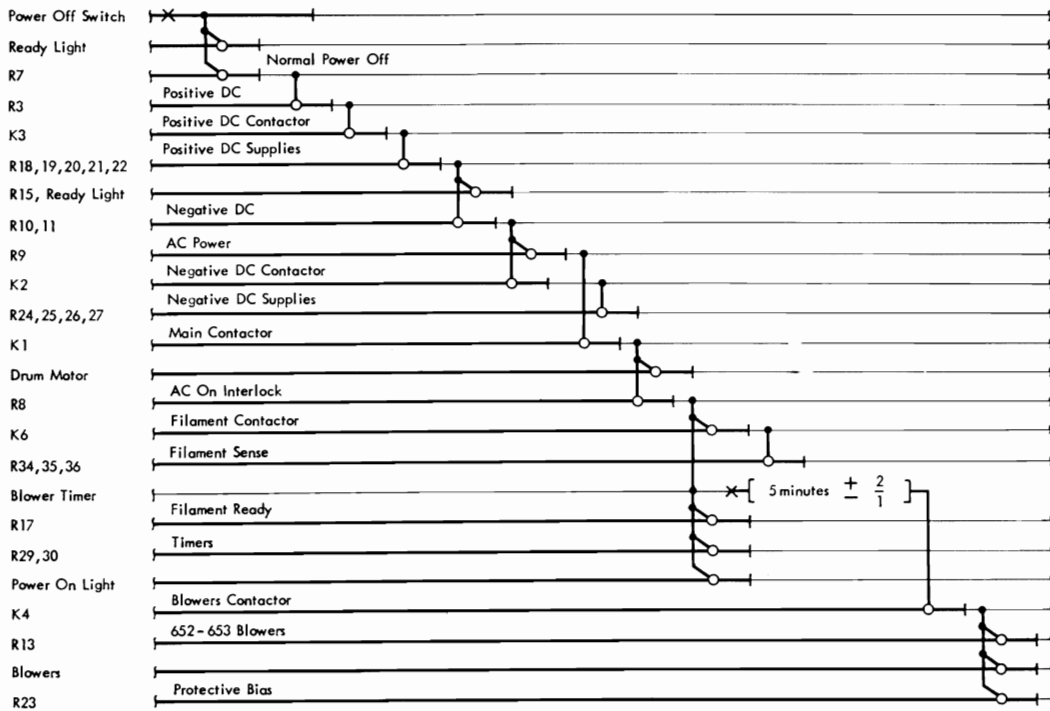

Figure IX-3. Power-Off Sequence

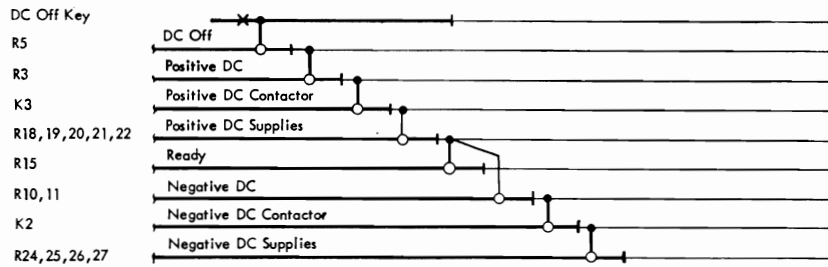

Figure IX-4. DC-Off Sequence

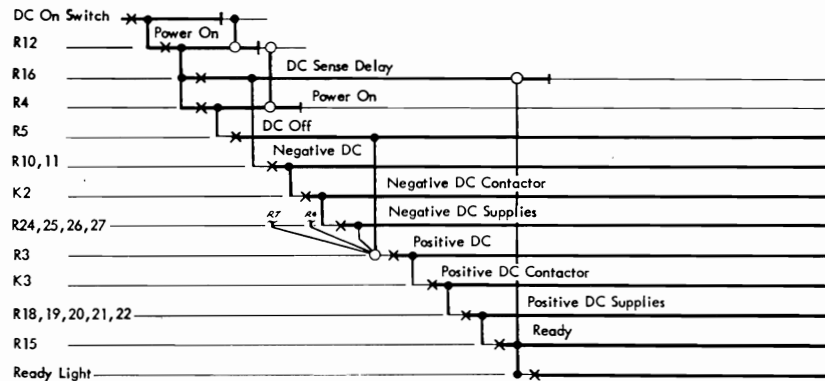

Figure IX-5. DC-On Sequence

When the power is removed by depressing the POWER-OFF key, sequence shown in Figure IX-3 will take place. Power may be reapplied by depressing the POWER-ON key.

### DC-Off Sequence

A DC-OFF sequence will be initiated when the DC-OFF key is depressed or a blown fuse is detected in a dc circuit. The DC-OFF sequence is similar to the beginning of a POWER-OFF sequence. The last step is the removal of negative voltages. Figure IX-4 is an operation chart of a DC-OFF sequence initiated by depressing the DC-OFF key.

### DC-On Sequence

When the machine power is on and the dc voltages are off, depression of the POWER-ON key or DC-ON key will cause a DC-ON sequence. The operation is described in Figure IX-5.

### Master Power-Off Switch

A MASTER POWER-OFF switch is provided on both the console and the 655 switch panel, for emergency use only. This switch shuts off all power simultaneously. These switches are normally closed and are connected in series. Depressing either of these switches will drop R2 causing a circuit to be completed from one side of the line through CB1-3 coil and a 75-ohm resistor to the other side of the line when the R2A normally closed point closes. The current through CB1-3 causes CB1-1, 2, and 3 to open, resulting in removal of power from all circuits simultaneously. When the power is removed in this manner, it will be necessary to reset CB1 before power can be applied to the machine. All efforts should be made to apply power to the machine as soon as possible in all cases where a MASTER-POWER OFF has taken place. Thus, the blowers will prevent build-up of heat in the gates.

Figures IX-6 and IX-7 show the sequence of operations when a dc, or an ac fuse is blown respectively.

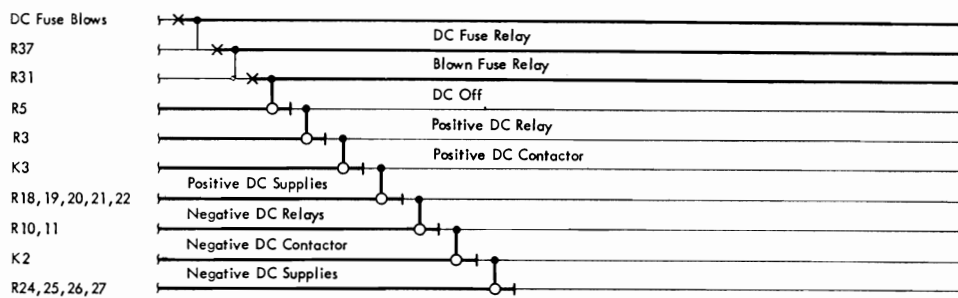

Figure IX-6. Blown DC Fuse Sequence

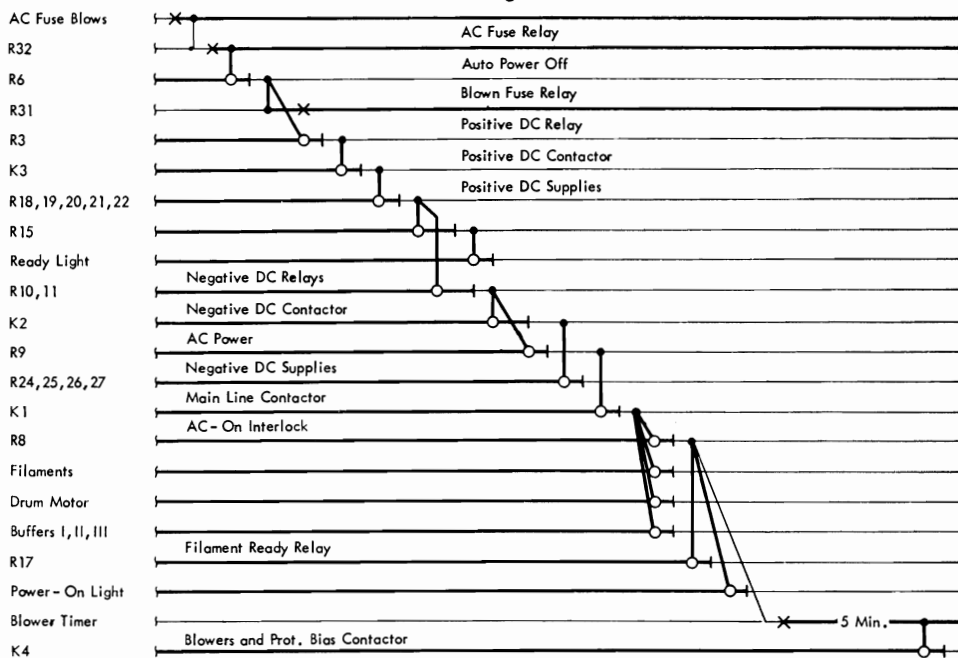

Figure IX-7. Blown AC Fuse Sequence

DESCRIPTION AND PURPOSE OF COMPONENTS

Contactors—115 Volts AC

- K1 Supplies line power to machine.  
Supplies power to drum motor
- K2 Supplies power to negative supply primaries.
- K3 Supplies power to positive supply primaries.
- K4 Supplies power to blower motors and primary of minus 63 volts supply.
- K5 Supplies reduced power to filaments.
- K6 Supplies full power to filaments.

Relays—42 Volts DC (except fuse and sense relays)

- R1 Emergency OFF. Picks and stays up as long as main power is on.
- R2 Emergency OFF. When dropped causes circuit breaker (CB1) to open, removing all power from machines.
- R3 Positive dc. Picks K3; causes power to be applied to plus voltage supply primaries.
- R4 Power ON. Starts POWER-ON sequence.

R5	DC OFF.	Starts a DC-OFF sequence when dropped.	R21	+70-volt control.	Indicates +70-volt supply operating (V3).
R6	Auto power OFF.	Starts POWER-OFF sequence when fuse blows or when a filament circuit fails in the 650, 652, or 653.	R22	+70-volt control.	Indicates +70-volt supply operating (V11).
R7	Normal power OFF.	Starts a POWER-OFF sequence when dropped.	R23	Protective bias relay.	Picked by -63-volt supply.
R8	AC-ON Interlock.	Supplies power to the time-delay relay elements (R29, R30). Turns on POWER-ON light. Provides circuit to blown fuse relay (R31). Controls operation of blower timer.	R24	-250 volts control.	Indicates -250-volt supply operating.
R9	AC power.	Picks K1. Supplies power to machine.	R25	-50 volts control.	Indicates -50-volt supply operating.
R10	Negative dc 652, 653.	Indicates 652, 653 negative supplies operating.	R26	-70 volts control.	Indicates -70-volt supply operating.
R11	Negative dc.	Picks K2; applies power to negative supply primary circuits in 655.	R27	-22 volts control.	Indicates -22-volt supply operating.
R12	Power ON.	When picked, it will cause (a) POWER-ON sequence if the machine is off (b) DC-ON sequence if the power is on and dc is off.	R29	Filament timer.	Controls period of reduced voltage to filaments.
R13	Blowers.	Picks when blower motor power is applied.	R30	Filament timer.	Controls period of full filament voltage prior to applying dc.
R15	Ready relay.	Picks when all positive supplies are operating.	R31	Blown fuse relay.	Indicates any blown fuse or filament failure in the 655, 652, or 653. This relay is of the latch-type and must be reset prior to restoring power.
R16	DC sense delay.	Prevents setting of blown fuse circuit during turn on sequence.	R32,		
R17	Filament ready.	Picks and stays up after filaments are at operating temperature.	R33	AC fuse relays.	Sense blown ac fuses.
R18	+250-volt control.	Indicates +250-volts operating for Read Circuits.	R34,		
R19	+250-volt control.	Indicates +250-volts operating for Write Circuits.	R35,		
R20	+150-volt control.	Indicates +150-volt supply operating.	R36	Filament sense relays.	Picked by filament supplies. Drop when filament circuit fails.
			R37,		
			R38	DC fuse relays.	Pick when dc fuses blow.
			<b>Timers</b>		
			BT	(5-minute timer).	Removes power from blower motors 5 minutes after POWER-OFF sequence.
			R29	Thermal.	30 seconds' reduced filament voltage.
			R30	Thermal.	30 seconds' warm-up.

# SECTION X. 533 MECHANICAL PRINCIPLES AND CIRCUITS

THE 533 Read-Punch Unit can perform all the card reading and card punching for the 650 calculator.

The read unit is almost identical to the 402 read unit. It contains two sets of 80 brushes called the first read brushes and the second read brushes. Figure X-1 illustrates a schematic of the read feed. The read feed operates at the rate of 200 cards per minute.

The punch unit is almost identical to the IBM Gang Summary Punch. It contains one punch station and one set of 80 brushes called the punch brushes. Figure

X-2 illustrates a schematic of the punch feed. The punch feed operates at the rate of 100 cards per minute.

## Punch Drive Mechanism

The power to drive the punch unit is furnished by the drive motor. The drive motor transmits power to the gear housing through a belt. The gear housing is almost identical to the 514.

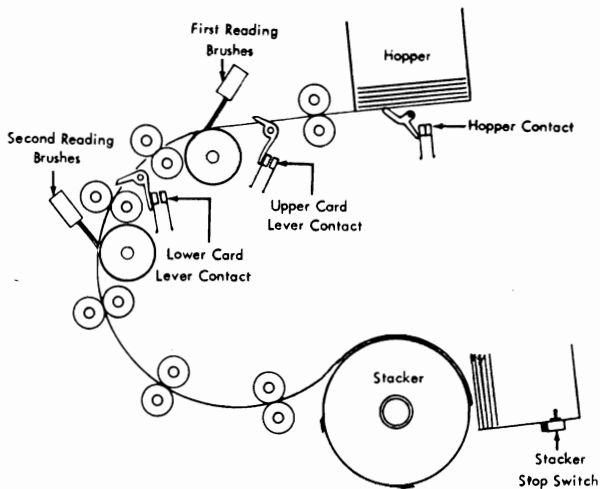

Figure X-1. 533 Read-Feed Schematic

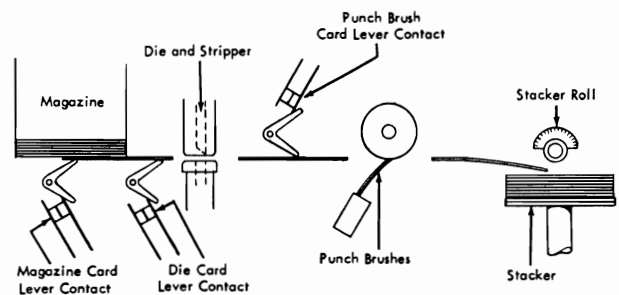
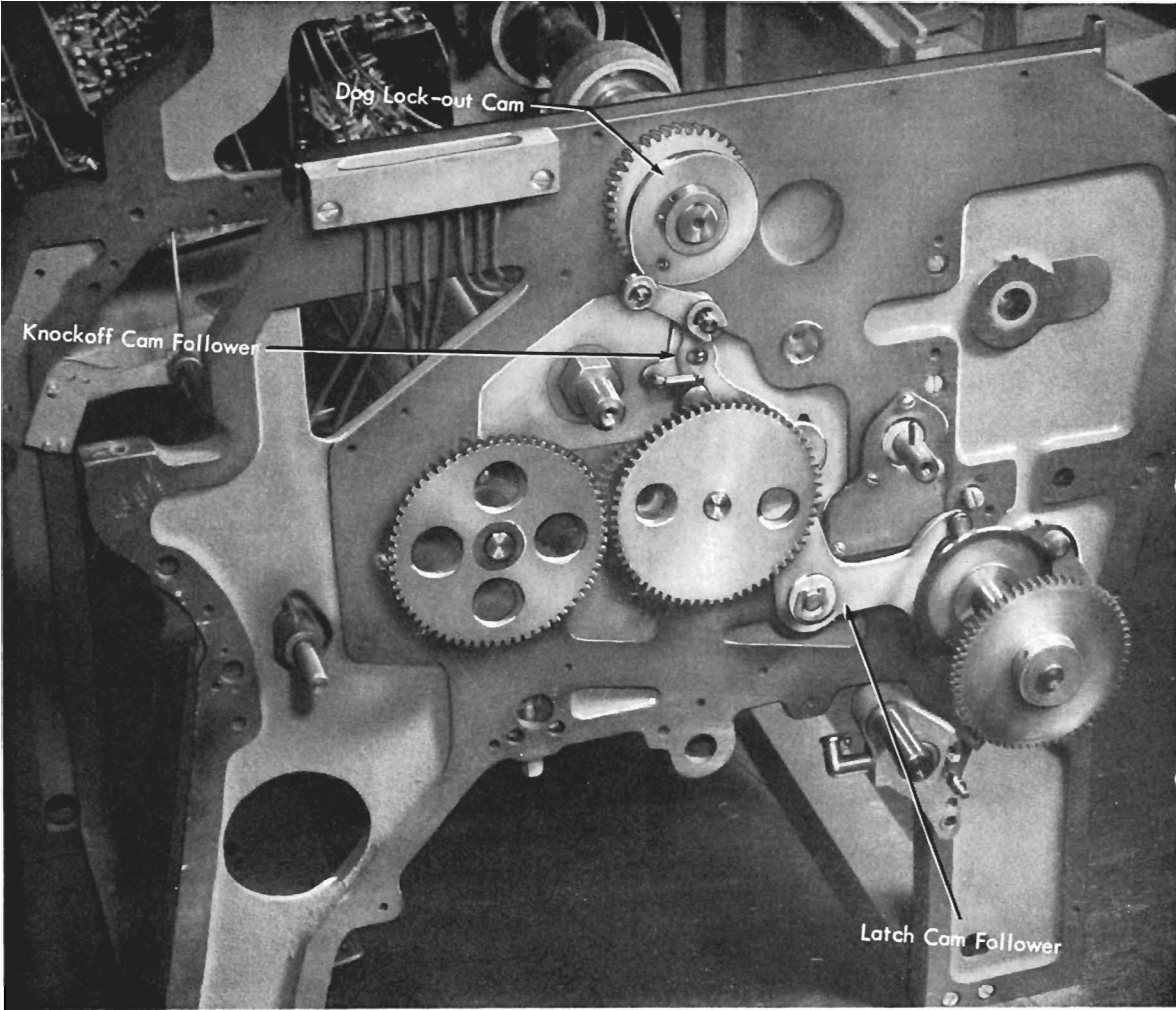

Figure X-2. 533 Punch-Feed Schematic





*Figure X-3. Geneva Pawl Disengaging Mechanism*

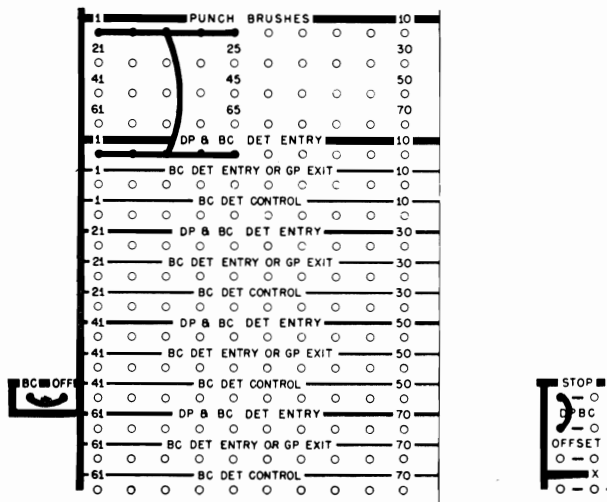

Figure X-4. Double-Punch Detection Wiring

The main mechanical difference is in the design of the latch cam follower, knockoff cam follower arm assembly and the dog lock-out cam (Figure X-3). The dog lock-out cam pinned to the eccentric shaft will make one revolution per digit time. The high part of the cam is timed to prevent the geneva pawl from engaging with the geneva seven-tooth ratchet unless the punch clutch is engaged. When the punch clutch is engaged, the latch cam follower will turn, rotating the knockoff cam follower arm assembly in a counter-clockwise direction. This will prevent the dog lock-out cam from operating against the knockoff cam follower arm assembly to keep the geneva pawl from engaging in the ratchet. The geneva pawl will then be free to engage in the geneva seven-tooth ratchet. The operation of the latch cam arm also prevents the geneva pawl from disengaging until the punch clutch is latched.

### Read Drive Mechanism

The power to drive the read unit is furnished by the same motor which supplied power to the punch unit. A pulley on the same shaft as the punch drive pulley drives the read unit through a timing belt. The read unit is almost identical to the 402 read feed. The main differences are the design of some of the feed rolls and gears to compensate for the increased speed. The read clutch has a 10-tooth ratchet, so it will engage without having to wait for a complete read cycle.

## CONTROL PANEL

REFER to the 650 Magnetic Drum Data-Processing Machine Manual of Operation (Form 22-6060).

## 533 CIRCUITS

(533 Wiring Diagram 254490B)

### DOUBLE PUNCH, BLANK-COLUMN DETECTION

THE double punch, blank-column detection circuit is used to detect a column that contains two punches or a column that contains no punches.

### Double Punch Detection Circuit (Figures X-4 and X-5)

Refer to Figure X-4 for the control panel wiring. The BC hub is wired to the OFF hub picking relay 316 from P16 so the blank column detection circuit will be inoperative. The DPBC hub is wired to the STOP hub to pick the double punch, blank-column stop relay 318. The punch brushes corresponding to the columns to be checked for double punches are wired to the DP and BC DET ENTRY hubs. Refer to Section 9A of the 533 wiring diagram. Assume that the column, wired to the first entry hub, contains a double punch. The impulse from the first hole will pick relay 319. Relay 319 will pick relay 320, and both relays will hold for the remainder of the feed cycle. The impulse from the second hole will go through relay point 320-2 N/O and pick relay 317.

At the beginning of the next feed cycle a DPBC DET error will result by picking relay 318. The following is the circuit to pick relay 318: P7, 315-2 N/O, 317-2 N/O, DPBC wired to the STOP hub, relay 318 pick coil. Relay 315 is picked through the circuits set up by the die card lever. Relay 318-4 N/C point opens and de-energizes relay 160. Relay 160-4 N/O point opens the circuit to the punch clutch magnets. Relay 318-3 N/C point opens to prevent the punch start key from operating the punch feed until the error circuits have been reset. Relay 318 will stay energized until the reset key is depressed.

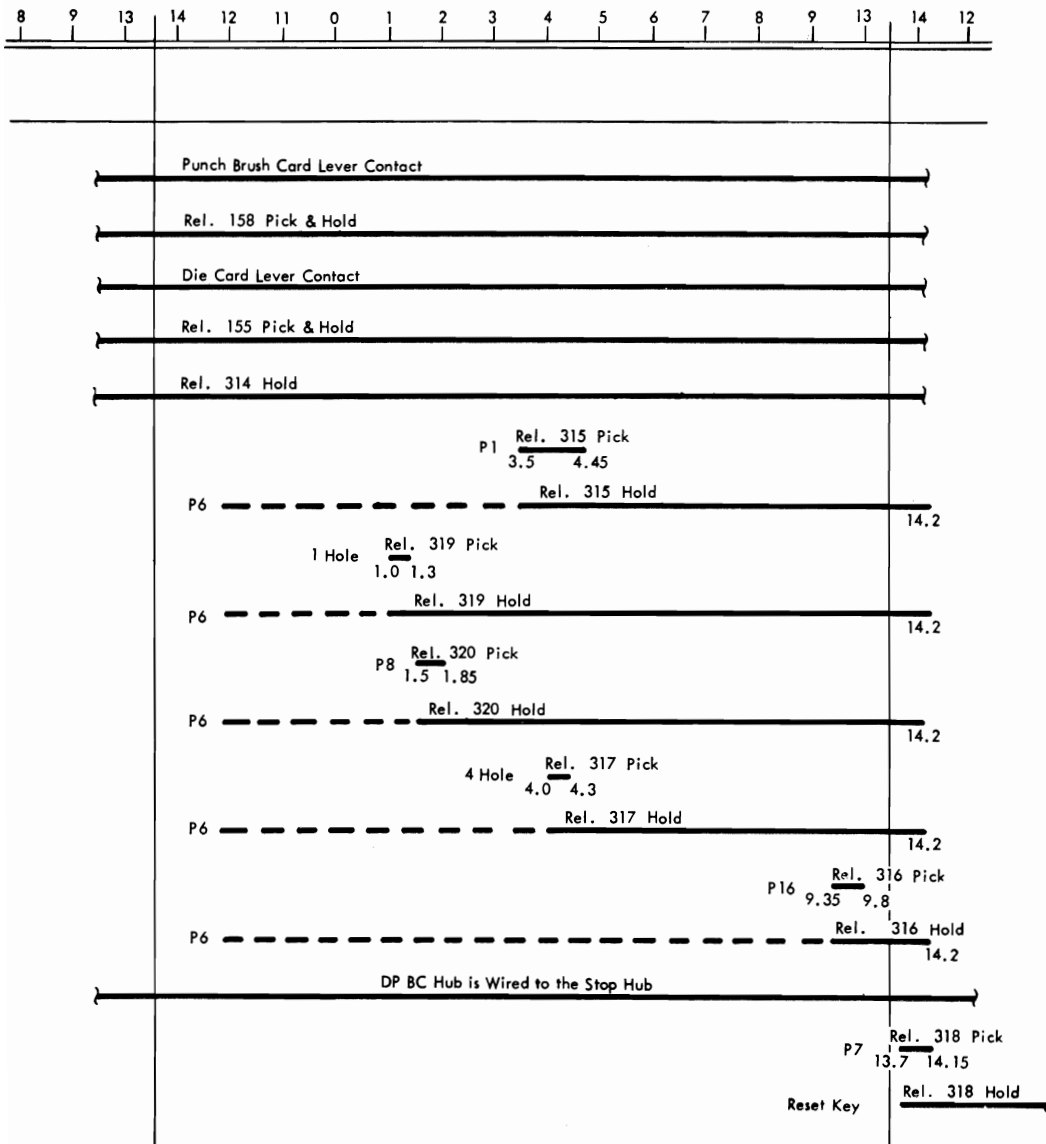

Figure X-5. Double-Punch Detection Timing Chart

### Blank Column Detection Circuit (Figure X-6)

Refer to Section 9A of the 533 wiring diagram. Wire the punch brushes to the DP and BC DET ENTRY hubs from the columns to be checked. Wire the DPBC hub to the STOP hub; the double punch, blank-column stop relay 318 will be picked when an error occurs. With this wiring the double punch detection circuits will be operative, as well as the blank column detection circuits.

For the machine to indicate that all columns checked have at least one punch, relay 316 must be picked. The circuit to pick relay 316 is from P16 through the normally open points of each relay, which is picked by the first digit impulse, in each position (relay 319-2 for position one). There may be a maximum of 80 of these points in series if the machine is equipped with 80 positions of DPBC detection. If only the first 10 positions are used, wire from the BLANK COLUMN DETECTION CONTROL hub number 10 to the high order hub, which may be the 80th position. This will short out the normally open points of the unused positions. The blank column detection control hubs must always be wired to provide a circuit around all unused positions.

Assume position number 1 is wired to a blank column. Relay 319 will not be picked and relay point 319-2 N/O will remain open to prevent relay 316 from picking. Relay point 316-2 N/C remaining

closed will provide a circuit to pick relay 318. A double punch or blank column error is detected when relay 318 is picked.

### Double Punch Detection Exit

These hubs may be wired to the punch magnets for a gang punch operation.

### PUNCH DELAY

THE PUNCH DELAY IN hub will accept any punch impulse from 13.8 to 9.8. During the following punch cycle, the OUT hub will emit an impulse between 13.7 and 14.5.

### Punch Delay Application

Storage exit C and storage exit B word 1 are selected by control information to punch into different columns. When the card passes the punch brushes, one cycle after it had been punched, a co-selector must be used to select the corresponding punch brushes for double punch, blank-column detection. The co-selector must be controlled by a one cycle delayed control information impulse.

### Punch Delay Circuit

Refer to section 4B of the 533 wiring diagram. The input impulse will pick relay 306, which will hold to 9.8; at 9.3 through the relay 306-2 N/O point, relay 307 will pick. Relay 307 will hold until 14.2 of the next feed cycle through P6. A punch delay out impulse will be obtained through the 307-2 N/O point and P21 between 13.7 and 14.15 of the next feed cycle.

### CONTROL INFORMATION

CONTROL information permits the operation of devices such as selectors and punch delay from information that has been stored or developed in the 650. The device utilizes the tenth word of punch-buffer storage, and the impulses produced are brought out at ten sets of hubs at AK to AM, 55 to 64 on the control panel. Any control information hub will emit an impulse when the corresponding position in punch-buffer storage has an *eight* stored in it. This impulse will occur at 14 punch index time.

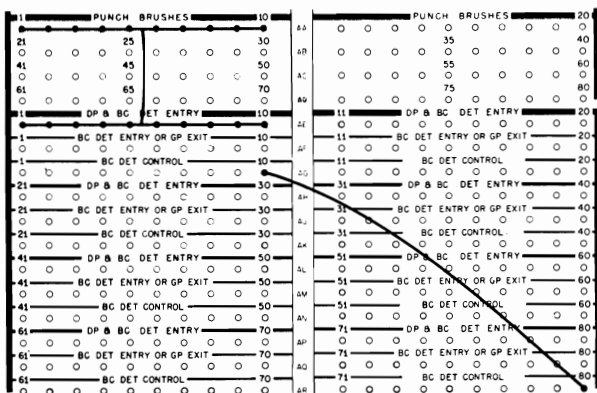

Figure X-6. Double-Punch and Blank-Column Detection Wiring

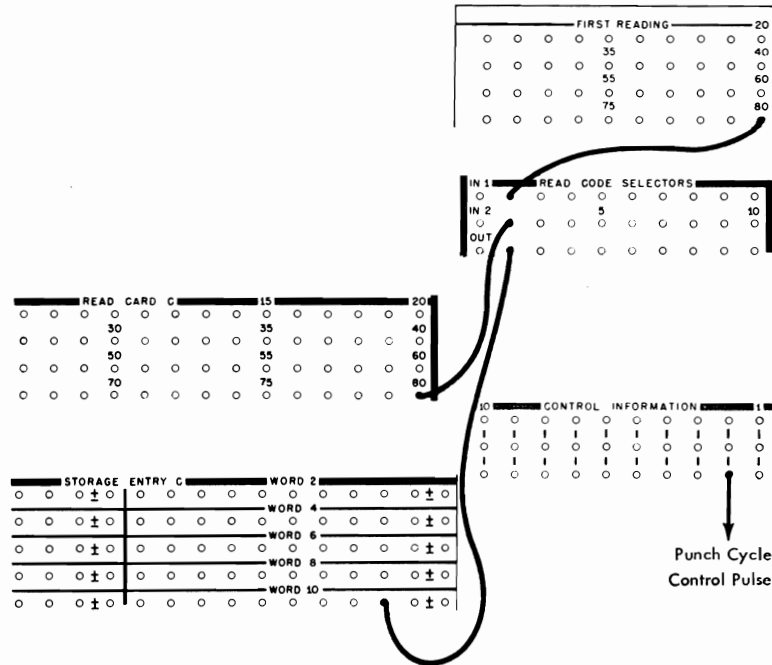

Figure X-7. Read Code Selector Control Panel Wiring

Objective: Emit a pulse from a Control Information Hub, when an 8 is stored in the corresponding position of PBS Word 10.

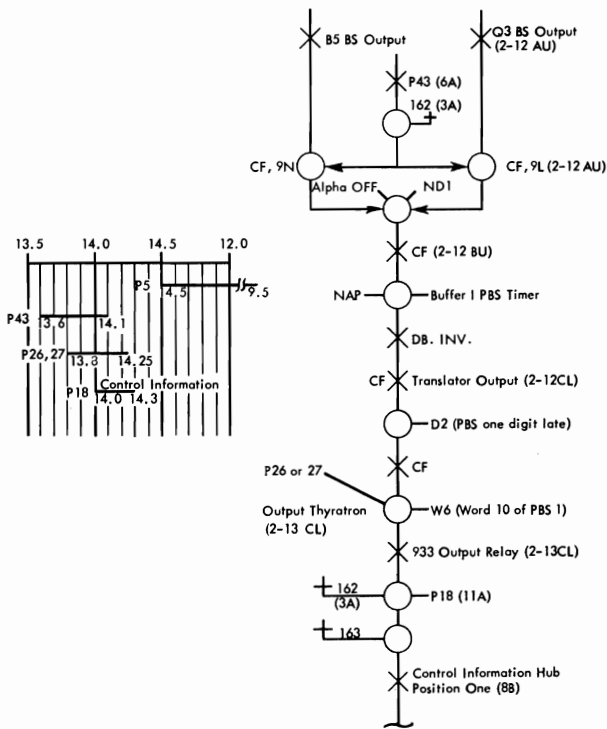

Figure X-8. Control Information—Position One

### Control Information Application

A read card contains a 12 through 7 punch to control output punching. A read code selector is used to convert the control punch to an 8 impulse and through a control panel wire, it is read into general storage (Figure X-7). For the punch-out operation the 8 is transferred to one of the digit positions of PBS word 10. The corresponding digit position of control information will emit an impulse between 14.0 and 14.3 of the punch cycle. This impulse may be used for various purposes, such as transferring selectors, picking punch A or punch B, or punch delay circuits.

### Circuit Description (Figure X-8)

Refer to Figure X-8 for the location of units. The following is a circuit description of position number 1 of control information:

The B5, Q3, outputs of buffer storage are applied to the grids of 9N and 9L. The plate circuits of 9N and 9L obtain a +150 volts from a special circuit through 162-2 N/C, 162-1 N/C and P43. The simultaneous outputs of 9N and 9L are switched at 6T. The output of 6T will pass through the punch scan matrix to the grid of the output thyatron. The plate of the thyatron receives plate voltage from P26 and

P27. The output of the thyatron provides a circuit to the control information output through the 163-1 N/C point.

### READ CODE SELECTOR

REFER to Section 11 of the 533 wiring diagram. Each read code selector has two input hubs (IN 1 and IN 2) and one exit hub (OUT). The outputs of the OUT hub may be an 8, 9, or no impulse, depending on how the IN hubs are conditioned. The chart below illustrates all the possible conditions and results.

In 1	In 2	Out
one 12-7 impulse	one 12-7 impulse	8 impulse
one 12-7 impulse	no impulse	no impulse
no impulse	one 12-7 impulse	no impulse
no impulse	no impulse	9 impulse

The read code selector operation sequence chart (Figure X-9A) shows that the IN 1 hub is impulsed one cycle before the IN 2 hub. The output from the out hub is obtained during the second feed cycle.

#### Read Code Selector Application (Figure X-7)

All problem cards that contain an X in column 80 will have their answers punched in columns 20 to 25 instead of columns 10 to 15. The IN 1 hub will be wired from column 80 of the first reading. The IN 2 hub will be wired from column 80 of the second read. The OUT hub will be wired to any digit of storage entry word 10. When a card containing an X in column 80 impulsed the IN 1 and IN 2 hubs, the OUT

hub will emit an 8-impulse, which is eventually placed in one of the digits of word 10 of PBS. At 14 time during the next punch cycle, a corresponding hub of control information will emit an impulse. This impulse will transfer a selector so the punching will occur in columns 20 to 25.

If the OUT hub emits an 8 impulse, control information will emit an impulse at 14 time. If the OUT hub emits a 9 impulse or no impulse, control information will not emit an impulse.

#### Circuit Description (Figure X-9A and 533-12A)

Any 12 through 7 impulse into the IN 1 hub will pick relay 659. Relay 659 will hold into the next feed cycle where it will pick relay 660. During the cycle in which relay 660 is picked, any 12 through 7 impulse into the IN 2 hub will pick relay 661. The 660-2 N/O and 661-2 N/O points will provide a circuit to emit an 8 impulse out the the OUT hub. If neither relay 661 or 660 is picked, the OUT hub will emit a 9 impulse. If just one of the two relays is picked, the OUT hub will not emit an impulse.

#### RSO (Read Second Only) Wired (Figure X-9B)

When RSO (533-12A) is plugged, the 655-2 N/O point shorts out the one cycle delay circuit and provides a circuit from the IN 1 hub to relay 660. To obtain the desired results from the example previously discussed, the IN 1 and IN 2 hubs must be wired from the second reading brushes.

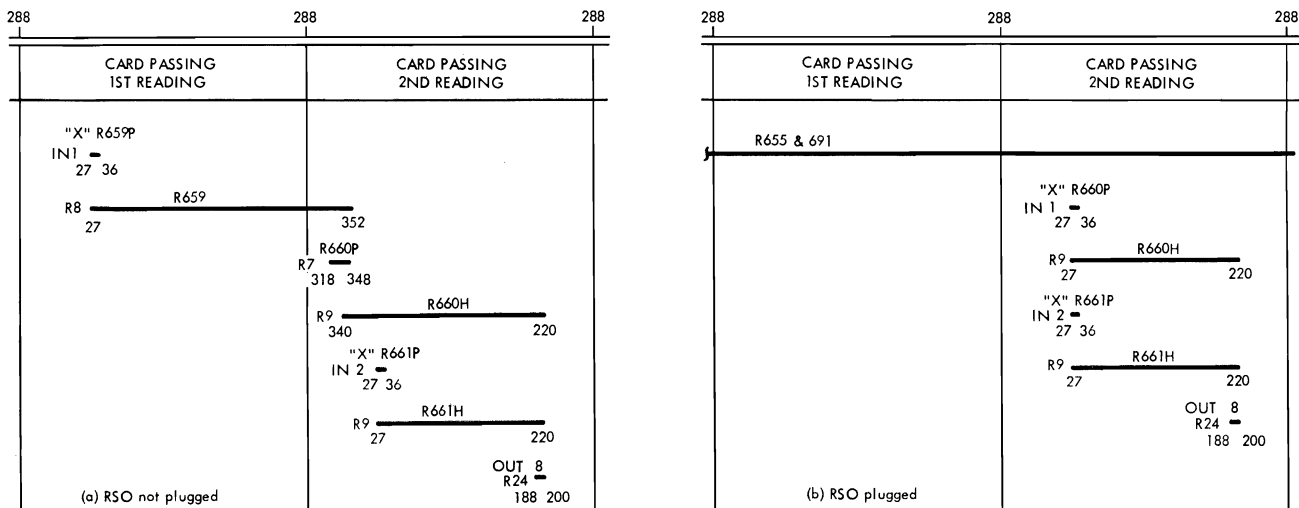

Figure X-9. Read Code Selector Operation

## READ FEED CIRCUITS (Figure X-10)

The read clutch magnet in the 533 is under control of R7 1 and 2 points in section 13B of 533 wiring diagram. Relay 7 hold coil (14A) is operated for the first three card feed cycles under control of the read start key and card lever circuits. During the third card feed cycle, R9 is picked by action of the card lever circuits and R9-5 N/C points (14A) are opened. Control of card feeding is transferred to the 650. The next pulse to pick R7 comes to the pick coil as a result of a code 70, 73, or 76 in the 650. The code which is involved depends on the buffer to which the 533 is attached.

1. First feed cycle. Relay 7 hold coil is operated by a circuit from 50V-3 (14A) through the stacker stop, read start 1 key, 10-4 N/C, 13-4 N/C, 16-3 N/C, 142-4 N/O, 8-4 N/C, 9-5 N/C, and R7 hold coil.

2. Second read feed cycle. Relay 7 hold coil is operated by a circuit from 50V-3 (14A) through the stacker stop, 142-3 N/O, 13-3 N/C, 1-2 N/O, 16-2 N/O, 13-5 N/C, 2-3 N/O, 5-2 N/C, 6-2 N/C, 9-5 N/C, and R7 hold coil.

3. Third read feed cycle. Relay 7 hold coil is operated by a circuit from 50V-3 through the stacker stop, 143-3 N/O, 13-3 N/C, 1-2 N/O, 16-2 N/O, 13-5 N/C, 2-3 N/O, 5-2 N/O, 3-3 N/O, 6-2 N/C, 9-5 N/C and R7 hold coil.

4. All read feed cycles after the third. Control of feeding of cards passes to the 650 during the third card feed cycle by the pick of R9. The circuit to pick R9 is from 50V-3 through the stacker stop, 142-3 N/O, 13-3 N/C, 1-2 N/O, 16-2 N/O, 13-5 N/C, 2-3 N/O, 5-2 N/O, 3-3 N/O, 6-3 N/C, 3-4 N/O, R12, and R9 pick coil. R7 is operated by a circuit through R46 (14A) R7 pick coil, RC4, and a thyatron in the 655. Refer to *Input-Output Codes*, Section 7.

To provide a machine stop and a feed check light if extra feed cycles occur. Extra feed cycles could be caused by improper clutch adjustments. R7 would not be operated, allowing R-cam 28 to drop R142 (13B) at 295°. R142-3 N/O points allow R-cam 19 to drop R9 (14B) at 228°. With R9 down, the 650 loses control of the 533 read feed, providing a machine stop. R142-2 N/O (2B) provides a circuit to the feed check light.

## PUNCH FEED CIRCUITS (Figure X-11)

The punch clutch magnet in the 533 is under control of the R160-4 points in section 4A of the 533 wiring diagram. R160 pick coil (4A) is operated initially by a circuit through the punch start key (3A). R160 holds for the two cycles of run-in. After the run-in, control of punching is transferred to the 650 by the pick of R161. Any punch feed cycles after the run-in are provided by the pick of R160 (4A) through the 161-2 and 166-2 points. R166 is operated by the development of a code 71, 74, or 77 in the 650. The code that is involved depends on the buffer to which the 533 is attached.

1. First Punch Feed Cycle. Relay 160 pick coil is operated by a circuit from 50V-3 through the punch start 1 key, 318-3 N/C, 155-6 N/C, 158-5 N/C, CRP1, and R160 pick coil.

2. Second Punch Feed Cycle. Relay 160 holds through 160-1 N/O (4A) and P13 until 9.2 of the first punch feed cycle. R160 holds from 9.2 to 9.7 through 160-2 N/O, 156-2 N/C, 143-3 N/O, 155-1 N/O, and 157-2 N/O to 50V-3. R160 then holds through 160-1 N/O and P13 until 9.2 of the second punch feed cycle.

3. All Punch Feed Cycles after the Second Control of feeding cards passes to the 650 after the second punch feed cycle by the pick of R161 (4A) calculate interlock. R161 is operated by a circuit from 50V-3 through P1, 158-1 N/C, 155-5 N/O, and R161 pick coil. R161 holds through 161-1 N/O, 143-3 N/O, 155-1 N/O and 157-2 N/O. The punch start relay, R160, is now under control of the 166-2 N/O points (4A). R166 is operated by a circuit through P25, R166 coil (5A), PC32, and a thyatron in the 655. Refer to *Input-Output Codes*, Section 7.

To provide a machine stop and a feed check light if extra feed cycles occur. Extra feed cycles could be caused by improper clutch adjustments. R166 would not be operated, allowing P-cam 4 to drop R143 (3A) at 13.6. With R143 down, the 650 loses control of the 533 punch feed. R143-2 N/C (2B) provide a circuit to the feed check light.

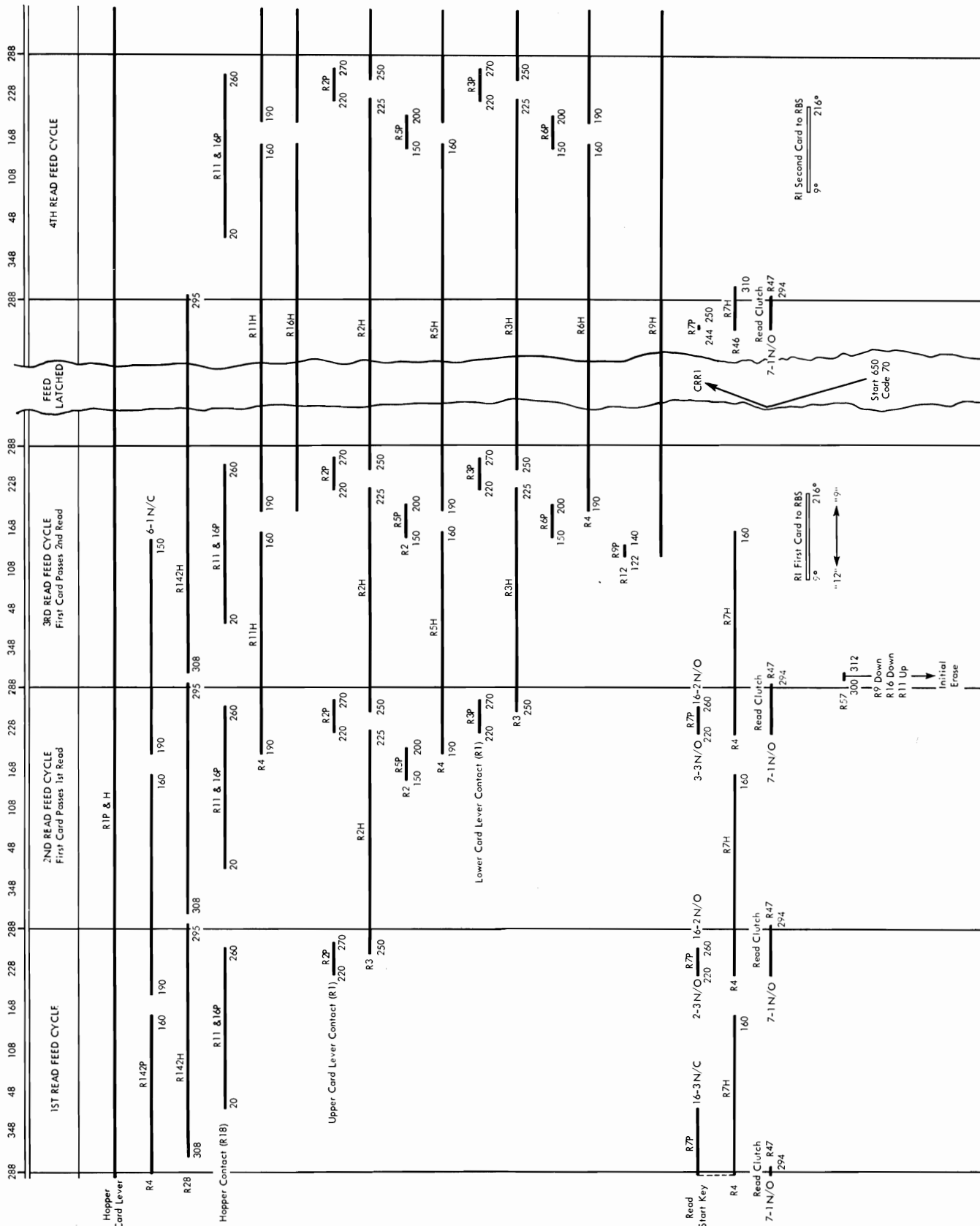

Figure X-10. 533 Read-Feed Run-In Timing Chart



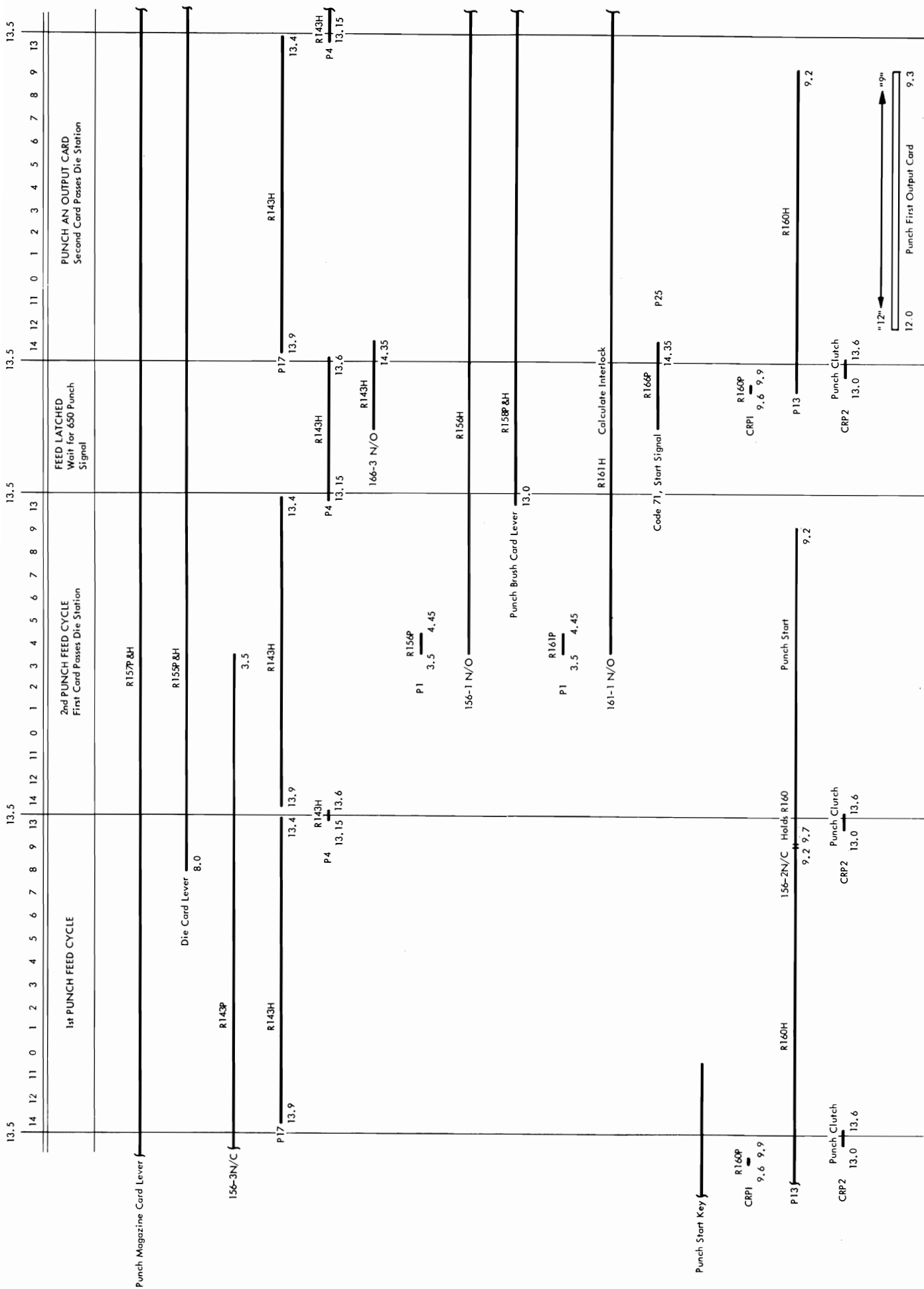

Figure X-11. 533 Punch-Feed Run-In Timing Chart

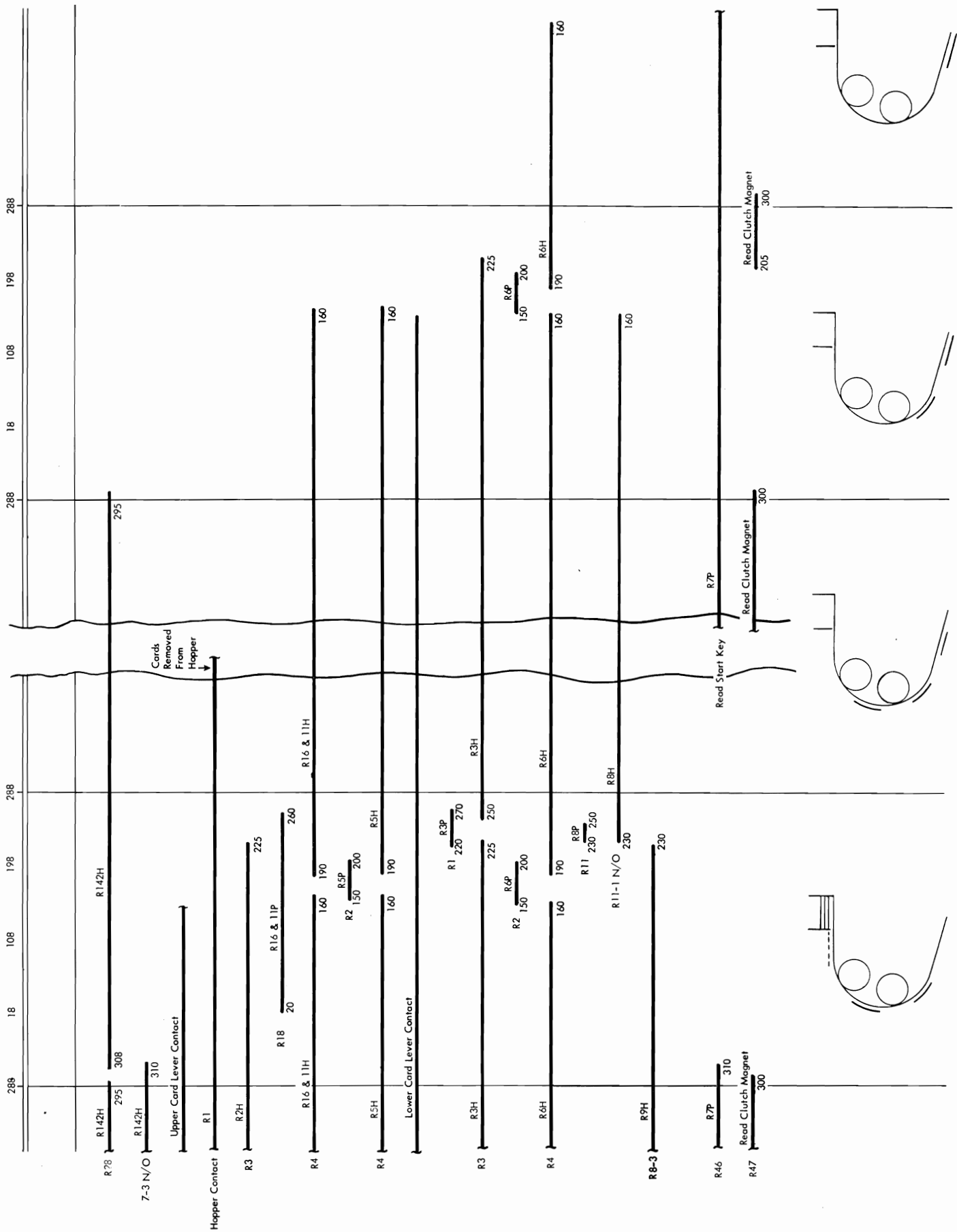

Figure X-12. 533 Card-Feed-Stop Timing Chart

## CARD FEED STOP

WHEN a read feed failure occurs, the 650 loses control of the feed circuit. The 650 will progress to the next feed cycle and hang up. In order to restore the card feeding back to normal and calculate all the cards, the following procedure must be followed:

1. Remove the cards from the hopper.
2. Run all the cards into the stacker by depressing the read start key.
3. Remove the last two cards from the deck in the stacker and place them on the bottom of the deck yet to be fed. These cards have not been calculated.
4. Run the uncalculated cards into the feed in the normal manner. After the third run-in cycle the 650 will automatically signal for a feed cycle to calculate the first card.

### Circuit Operation (Figure X-12)

Refer to sections 13 and 14 of the 533 wiring diagram. When a card fails to feed from the hopper, the upper card lever contact will open and relay 2 will de-energize. Relay 2-3 N/C points will provide a circuit to pick the card feed stop relay 8. Relay 8 will hold under control 11-1 and 13-3. Relay 8-3 points will open the hold circuit to relay 9 to prevent the calculating of the last two cards during the run-out. Relay 8-4 points will render the start key useless until the cards have been removed from the hopper.

After the cards are removed from the hopper the read start key will provide a circuit to pick relay 7 and cause feed cycles to run the cards into the stacker. The last two cards that were fed must be placed on the bottom of the uncalculated deck. This deck should then be run-in using the read start key. The three run-in cycles will take place in the normal manner.

### END OF FILE

REFER to the end-of-file sequence chart (Figure X-13).

When the hopper becomes empty, the hopper contact will open and the read feed will stop at the end of the current feed cycle. If the read start key is depressed, all cards will feed into the stacker, and the last three cards will not be calculated. If the end-of-file key is depressed, the read feed will be placed under the control of the 650. Three automatic feed cycles will occur, and the last three cards will be calculated. The read start key is used to run the remaining cards into the stacker.

### Circuit Operation

Refer to sections 13 and 14 of the 533 wiring diagram. The hopper contact opens at 220 degrees and de-energizes relay 1. Relay 1-4 N/O points opens the pick circuit to relay 9. With relay 9 de-energized, the read feed will not operate under the control of the 650. Relay 10 is picked by the end-of-file key number 1 through the following circuit: 50V-3, stacker stop switch, 142-3 N/O, 13-3 N/C, 1-4 N/C, 6-4 N/O, 13-6 N/C, R14, end-of-file key number 1, relay 10 pick coil. After relay 9 is picked through the 10-3 points, the 9-2 N/O and 9-3 N/O points (section 13B) will be used to enable the 650 to control the read feed.

After the third feed cycle, the last card will be calculated. The 650 will then lose control of the read feed. Relays 9 and 10 will be allowed to drop out by the second read delay relay 6-4 N/O point. The 10-4 N/C and 9-5 N/C points will now provide a circuit from the read start key to pick relay 7 so the remaining cards in the feed may be run into the stacker.

## PUNCH CODE SELECTOR

REFER to section 11B of the 533 wiring diagram. Punch code selectors may be picked by any punch impulse from 13.8 to 9.8. The selector will hold for the remainder of the punch cycle through P19.

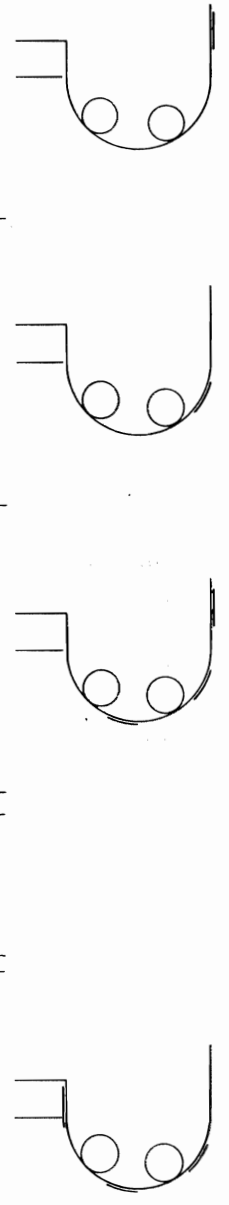
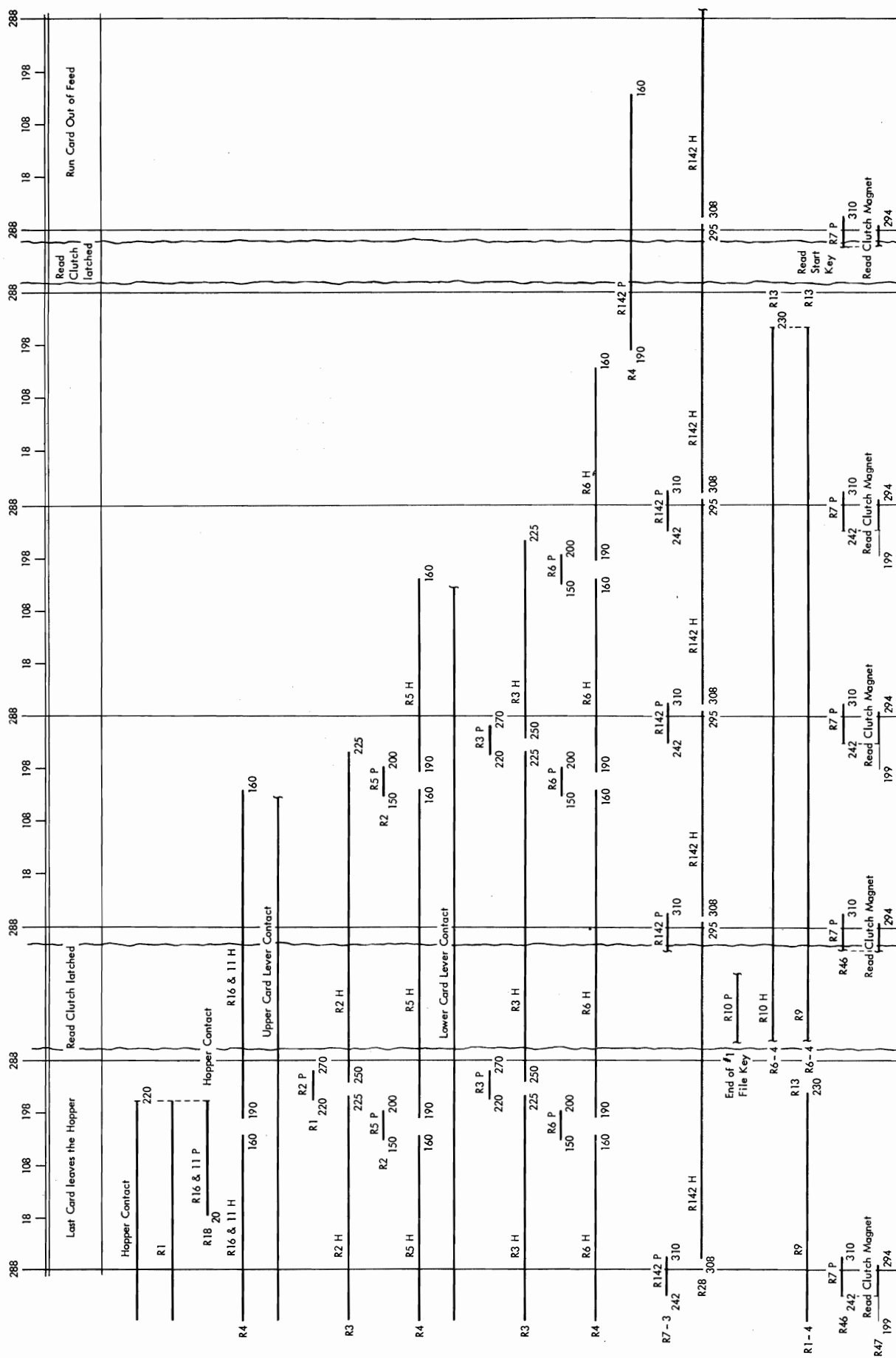

Figure X-13. 533 End-of-File Timing Chart

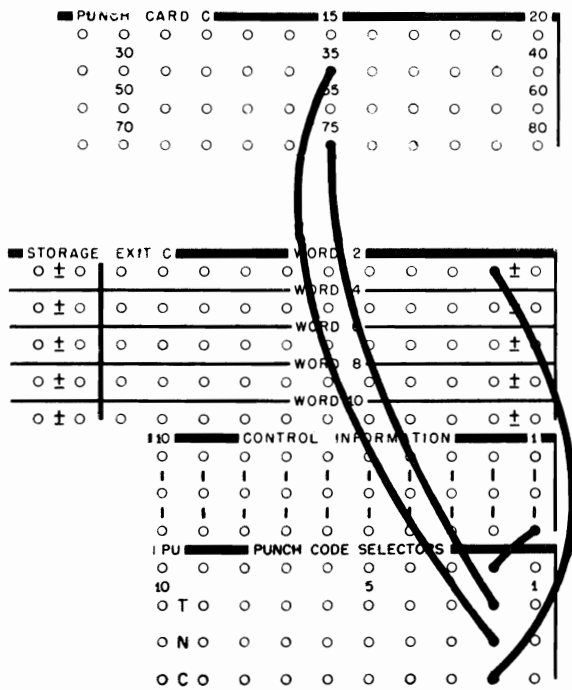

Figure X-14. Punch-Code-Selector Control Panel Wiring

**Punch Code Selector Application (Figure X-14)**

The units position of word 2 of storage exit C emits a digit impulse. This impulse should normally punch a hole in column 35. The units position of control information emits an impulse, transferring punch code selector number 2. The digit impulse will then pass through the transferred point of the selector and punch a hole in column 75.

**CO-SELECTORS**

REFER to section 10B of the 533 wiring diagram. A co-selector may be picked by either a punch impulse or a read impulse. The hold circuit is determined by control panel wiring to the hold punch or hold read hubs.

If a co-selector is to be used for a punch cycle, a punch impulse must be used to pick the selector. The hold punch circuit must be used to provide a hold circuit. The co-selector can be picked and held from 13.8 to 9.8 of a punch cycle.

If a co-selector is to be used for a read cycle, it must be picked by a read impulse and held through the hold read circuit. The co-selector can be picked and held from 340 to 220 degrees of a read cycle.

**PILOT SELECTORS**

REFER to section 10A of the 533 wiring diagram. A pilot selector may be picked by a read impulse or a punch impulse. The XPU and DPU hub must receive a read impulse to transfer the selector. The IPU hub may receive a read impulse or a punch impulse to transfer the selector. The read or punch wired hold circuit should be used to correspond to the pick impulse.

The XPU and DPU provide a cycle delay; for example, an impulse from the first reading brushes will transfer the selector when the card passes the second reading station.