

Church

COLLATOR

TYPE 077

MANUAL OF INSTRUCTION
CUSTOMER SERVICE



INTERNATIONAL BUSINESS MACHINES CORPORATION
590 MADISON AVENUE, NEW YORK, N. Y.

INTERNATIONAL COLLATOR

The International Collator is a machine designed for card-arranging operations now performed by hand, or with Sorters. Its principal function is to match or merge two sets of cards as required, in preparation to their use in gang-punching, multiplying and tabulating.

GENERAL DESCRIPTION

The machine has two horizontal feeds, one over the other, on the right end, and the cards are received by the stacker pockets (four in number) to the left of the feeds. Numerical information only can be used for collating operations. There is a hinged joggle plate over the stacker pockets.

The machine is equipped with an automatic plugboard, which is located on the right end of the machine. All relays are located in the relay cabinet in the rear of the machine. The sentinel type main line switch, and the various keys are located on the front of the machine near the right end. A test light outlet is located on the left rear upper base.

The four legs are equipped with casters, which make the machine easily movable. The covers may be readily removed without the use of any tools.

FUNCTIONS

The Collator supplements the customary process of punching, sorting, and tabulating by providing an automatic means of associating different sets of cards. This operation is required in the maintenance of files, and is frequently necessary before gang punching, multiplying, and tabulating.

Unlike the Sorter, this machine requires only one passage of the cards. The machine does not change the sequence of the cards, and therefore requires that the cards be in numerical sequence before the collation is started.

The types of operations performed by this machine are briefly listed below:

Filing current transactions with previous transactions and old balances.

Pulling debits by means of credits.

Combining master or name and address cards with detail cards.

Re-filing master or name and address cards after use.

Substituting new master or name and address cards for those made obsolete.

Segregating all debits in arrears.

Eliminating last cards of groups or single cards.

Checking the sequence of a card file.

Each of the above operations is performed with one passage of the cards through the machine, during which all columns in the control fields of the cards are read simultaneously.



Current

The machine is equipped with a motor generator set, which furnishes the necessary 40 volt D.C. operating current. The motor generator set and the drive motor can be furnished to operate from any standard D.C. or A.C. source. The motor generator set and the drive motor are located on the lower base, and are readily accessible through the front and left end lower base covers. As there is no means of increasing or decreasing the height of the motor, the machine is equipped with an adjustable drive belt.

The output of the generator is controlled by a variable resistor located at the left center of the relay cabinet.

The starting and running current for the drive motor and generator are as follows:

<u>Current Ratings</u>	<u>Starting Amps.</u>		<u>Running Amps.</u>	
	110 V	220 V	110 V	220 V
DC	22.0	11.0	3.6	1.8
AC 60 Cycle Single Phase	27.0	13.5	10.0	5.0
AC 50 " " "	27.0	13.5	10.0	5.0
AC 25 " " "	25.7	12.0	7.0	4.6

MACHINE DESCRIPTION

Speed

The output of this machine in cards per minute varies according to operation and the number of cards per control number, and ranges from 240 to 480 cards per minute. Irrespective of the output, the machine will go through 240 machine cycles per minute.

Card Capacity

The standard card capacity is 80 columns.

Stackers

Four stackers are provided for the cards, each one having a capacity of approximately 1000 cards. Each stacker is equipped with a stacker stop which automatically stops the machine when any one pocket fills to capacity.

Reading from right to left, the stackers are: 1. Selected Primaries; 2. Merged Cards and Primaries Not Selected; 3. Separate Secondaries Not Selected; 4. Selected Secondaries.

When merging or matching two sets of cards, the stacking of the cards is controlled by the manually operated secondary control lever on the first machines, which is set before the cards are run, and on the latest machines this is electrically controlled by the secondary select magnet assembly which replaces the manually operated secondary control lever.

Switches and Keys

Main Line Switch

This switch is a sentinel switch, and will automatically open the main line circuit when there is an overload on the machine. There is a chart on the wiring diagram showing the various thermal elements to be used in this switch. When this switch is open, it does not open the line to the test light outlet. This outlet is protected by 2 amp. fuses.

Plugboard Switches

The various operating switches are incorporated in the plugboard. These switches should be plugged either "Off" or "On" when operating the machine.

Keys

The machine is equipped with four control keys, which are located on the front of the machine to the right of the main line switch. These keys, reading from left to right, are "Error Reset Key," "Run-out Key," "Stop Key," and "Start Key."

The Error Reset Key is used to extinguish the error light and restore the machine to normal when errors appear during checking operations.

The Run-Out Key is used for removing cards which remain in either feed at the end of a run.

The Start and Stop Keys are used for what their names imply.

Error Light

The error light is located below the control keys. When checking the sequence of primary cards during a filing or pulling operation, the machine will stop and the error light will light whenever the comparing unit determines that a primary card is followed by another containing a lower control number. After the depression of the error reset key, the light is extinguished, and the machine should be run for two cycles to bring the second card, which is in error, into the stacker.

Dimensions and Weight

Length, 45"; Width, 19"; Height, 50".

Weight Packed, 960 lbs.; Unpacked, 732 lbs.

UNITS AND ADJUSTMENTS

Figure-1 is a schematic drawing of the machine showing the locations of various units, and the progress of the cards through various machine cycles.

Variable Speed Drive Mechanism - Fig. 2.

The drive mechanism is shown in Fig. 2. The reason for this mechanism operating at variable speeds is to slow the machine down when drive clutches latch and unlatch, thereby eliminating undue strains on latches, taper pins, etc. There are



no adjustments on this drive, but it is essential to keep it well lubricated with IBM Lubricant #18.

The main drive shaft gear (1) travels at a constant speed of 192 CPM. The variable speed motion is transmitted from this gear to the main drive shaft (8) by means of the variable speed mechanism. This is accomplished as follows:

The variable speed cam follower (3) is connected to the main drive shaft gear by means of the cam follower drive stud (7).

Motion is transmitted from the cam follower to the variable speed shaft lever (5) through the drive stud (6). The variable speed shaft lever is pinned to the drive shaft (8).

As the main drive gear rotates, the roller on the cam follower travels in the internal cut of the variable speed cam. This motion changes, by means of the cam follower and shaft lever, the relationship of the driving point (7) on drive gear to the pivoting point of the mechanism or the drive shaft. This change in the relationship between these two points, stud (7) and the drive shaft, results in the variable speed.

FEEDS FIG. 1

There are two clutch-controlled feeds equipped with standard picker knives. The upper horizontal feeding unit is the secondary feed and the lower feeding unit is the primary feed. The primary feed is located at an angle to the secondary feed so that the cards feeding in both units will meet at the intersection of the two feed lines and enter the stackers together.

The capacity of the feeds is approximately 800 cards each. The cards are placed in the feed face down with the "9" edge of the card feeding in first.

Hoppers

All the adjustments pertaining to the hoppers are standard horizontal feed adjustments. The front and back plates are adjusted when aligning the cards to the brushes horizontally, and there should be approximately .010" clearance over the length of the cards.

Card Guides

The card guides throughout the feeds are set at the factory for .020" clearance.

The card guide tips that are on the ends of the guides near the contact rolls should clear the rolls approximately .005".

Feed Rolls

All the floating feed rolls are adjusted for 10 to 12 lbs. tension, equal all the way across. The primary and secondary feed rolls are equipped with adjustable plungers, whereas, the remaining rolls have coil pull-springs.

Brushes

There are three sets of brushes; namely, the secondary reading brushes, which

are the upper brushes, the primary reading brushes, which are directly below the secondary, and the primary sequence brushes which are between the primary brushes and the primary feed.

The brush assemblies are pivoted and may be raised or lowered to facilitate the removal of jams, etc. The primary reading and the primary sequence brushes are assembled in one unit. The pivots of these units are removable to facilitate the removal of the entire assemblies from the machine for repair purposes.

To install a new set of brushes in an assembly, place a few brushes in each end of the brush holder. Adjust these end brushes to measure $1-1/64$ " from the heels of the brushes to the edge of the brush holder. Insert all the remaining brushes in the holder their full length. Remove the tension of the card brush guide roll by unhooking the tension springs of the pressure rollers (Fig. 3) Move the brush holder as far forward in the assembly as it will travel and fasten brush gauge #178087 (A) in place by means of its clamp hooks #178125 (B). The brush holder is then moved back until the first strand of the heels of brushes Nos. 1 and 80 drop off the edge of the tool. Tighten the brush holder screws and adjust the individual brushes so their heels just drop off the edge of the tool.

The brushes must be in the middle of the slots of the brush guide rolls. Check the guide rolls in the primary unit to line up with each other.

The brushes are timed by means of the feed knives, to make contact through the hole in the card 3° before the line of index, and break not earlier than 12° after the line of index. This timing will place the heels of the brushes $1/32$ " ahead (toward feed) of the center line of the brush guide roll when the roll is in the running position and the brush is on the card line.

Note: Under no circumstances are the brushes to be timed by moving the brush holders.

The picker drive cam (Fig. 6.) is clamped to its shaft and can be moved to permit timing the cards. It is very important to have the primary and sequence brushes in the primary feed in the proper relationship before timing the primary feed knives. This is set at the factory, and care must be exercised when dismantling that this relationship is not disturbed. Spot mark all gear trains, if it is necessary to dismantle for any reason.

High-Speed Contact Roll, Fig. 9

Figure 9 shows a cross-section view of the high-speed control roll used in this machine. This roll was designed especially for this machine to insure the contact surface being kept absolutely free of all scoring and dirt. The center or high-speed portion of the roll is gear driven; whereas, the idler sections on the ends are driven at card speed by the friction of the card on these sections. To insure correct readings, the cards must be fed by the "10" end sections and not by the high-speed section. Periodic check should be made for a $.005$ " clearance, as shown in Fig. 9 It is, therefore, essential to keep these idler sections free of all dirt and oil accumulation to insure their free operation. Adequate lubrication is essential due to the high speed at which these rolls operate.

Chute Blades

There are three chute blades which are controlled by two select magnet and armature assemblies, as shown in Fig. 4C. The upper assembly is the secondary magnet and controls the two upper chute blades (#11 and #12) which guide the cards from the

secondary feed into the secondary pockets. The lower blade (#10) which guides the cards from the primary feed into the primary pockets, is controlled by the lower or primary select magnet assembly.

The chute blades must be shaped as illustrated in Fig. 4C with the curvature starting at approximately the points shown. The body of the blades should be straight and parallel to each other, with some clearance between each blade. The tips of the secondary blades should be approximately $1/16$ " above the card line and the tip of the primary blade $1/16$ " below the card line when in their normal positions.

It is also essential to check the position of the tips of the blades when attracted. The tips of the secondary blades should be approximately $1/16$ " below the card line, while the tip of the primary blade should be $1/16$ " above the card line when their respective magnets are energized. These adjustments are obtained by bending the tips of the blades and not by shifting the select magnets.

The blades should have sufficient tension to follow the select shoes when the magnet armatures are restored to normal. Tension is applied to the blades by the same method as that used on sorter chute blades.

Select Magnets Fig. 4B

These assemblies are identical in construction with the exception that the secondary unit is a double unit owing to the fact that it controls two chute blades.

The upper or secondary unit is used to control the feeding of cards from the secondary feed into the 2nd, 3rd, and 4th pockets. The rear magnets, which are the match pocket magnets, control through their armature the second chute blade from the top. This chute blade in turn controls the feeding of cards from the secondary feed into pockets #2 and #3. The front magnets of the unit are the selected secondary magnets. When the selected secondary magnets are energized, an ear on the armature operates against the match pocket magnet armature, causing both top blades to be depressed below the card line. This in turn causes cards from the secondary feed to be placed into the 4th pocket.

The primary or lower assembly controls the feeding of cards from the primary feed into the 1st and 2nd pockets.

These units are under control of the punchings in the cards according to the set-up in the plugboard.

Adjustments Fig. 4B and 4C

1. Adjust the select magnet armature adjusting screw by loosening nut "B" for an approximate .015 unlatching clearance between the armatures and select shoe latches. This should result in .003 to .012 clearance between the cores and the armatures when the magnets are energized.
2. Adjust nuts "A" so the tip of the select magnet lever latch overlaps the armature the thickness of the stock of the armature to a maximum .005. (D)
3. With the armature latch operating stud on the high point of the select magnet lever restoring cam, there should be a .010" to .020" clearance between the latch and the armature. This is obtained by shifting the mounting brackets by means of screws "E." The stud must be in a horizontal plane so both armatures will

restore at the same time.

It is essential that the armatures unlatch without any load, and a check should be made to see that the armature just slides over the latch at 214° and at 216° the latch will keep the armature from latching.

When adjusting the secondary select magnet armatures, it is essential that the armatures be positioned so when attracted they will strike the shoulder of the armature adjusting screw, but must not bind against the screw. It is also essential that they do not touch each other at their lower extremities.

The latches should operate within the openings in the armatures without touching the sides of the openings, as well as being positioned so as not to strike the knock-off cam.

Eject Clutch Assembly - Fig. 4A.

This unit controls the ejection of primary cards from the primary brush station into the correct pockets.

The adjustments are as follows:

1. The eject clutch armature pivot plate "17" is adjusted horizontally for a .010" clearance between the end of the armature and the face of the clutch latch when the eject clutch gear knockoff block "16" fully operates against the clutch arm knockoff.
2. The eject clutch armature pivot plate must also be adjusted vertically to obtain a .025 overlap of the armature and latch when latched.
3. Shift the magnets by means of screws "C" for a .030" air gap between the armature and the left core when de-energized, and .003" air gap between the armature and the right core when energized. This provides .005" unlatching clearance at end of armature.
4. Adjust the clutch detent "14" for a .002" to .003" clearance between its end and the one-tooth ratchet on the eject clutch gear. This is obtained by stoning or peening the detent.
5. The eject magnet armature knockoff "13" should be adjusted for .003" to .005" clearance between the end of the armature and the latch as shown in "F" when in the extreme latching position.

If all of the above adjustments are correctly made, there should be from .015" to .025" clearance between the clutch latch and the clutch dog assembly when the magnets are energized.

Drive Feed Clutch Assemblies - Fig. 5A and 5B.

There are two drive feed clutch assemblies on the rear of the machine, which control the horizontal secondary feed shaft and the diagonally operating primary feed shaft. These clutches are pinned to their respective shafts, and it is essential that they latch and unlatch in synchronism when both feeds operate.

The adjustments of the old style units are as follows: Fig. 5B



1. When the clutch is latched, the armature backstop screw "B" should be adjusted for an approximate $1/16$ " overlap of the armature latch point and the clutch latch.

2. When the clutch is unlatched and the armature attracted, the armature stop "A" should be adjusted for an approximate .012" to .018" clearance between the latch and clutch, and an air gap of .005" to .008" between the armature and the core nearest the pivot point.

The adjustments of the new style units are as follows: Fig. 5A.

1. Set clutch latch by means of set screw so as to clear the clutch lever and dog assembly by .010" to .015" when in energized position.

2. Adjust armature plate horizontally for a .005" to .008" clearance between the latch and the end of the armature, when the latch is in the extreme camming position.

3. At the same time, the armature plate should be positioned vertically to provide a .020" to .025" overlap of the armature and latch in latch position.

4. Magnet bracket should be positioned to obtain a .025" air gap between the armature and the core farthest away from the pivot point with the armature in the de-energized position. The air gap at the point nearest the pivot point should be .003" with the armature energized.

5. Adjust the magnet armature knock-off screw to obtain .010" clearance between the armature and the knock-off, when the latch is in the extreme cam position.

SELECTOR CONTROL AND SEQUENCE CONTROL UNITS Fig. 10.

These units are located on the rear of the machine, and are identical in appearance, construction and function.

They are unlike the control units used in other accounting machines, as they are capable of determining not only whether two cards contain the same or different control numbers, but if different, which card contains the highest number, and which card contains the lower number.

The sequence unit is mounted on the rear of the machine to the right, facing front of machine.

The magnets in the upper section of the sequence unit are known as the second primary sequence magnets. The magnets in the lower section are known as the first primary sequence magnets.

The selector unit is mounted to the left of the sequence unit on the same plane. (facing front of machine)

The magnets in the upper section of the selector unit are known as the secondary selector magnets. The magnets in the lower section are known as the primary selector magnets.

Either unit may be plugged from any set of brushes as all brushes are on the same side of the line.

Each unit has 32 magnets which are pluggable in pairs permitting a comparison of sixteen digits in each unit. When using less than sixteen digits, it is not necessary to plug adjacent plug jacks. It is necessary to plug the magnets in pairs; i.e., if the first magnet is used on one side, the first magnet must be used on the other side pluggable to the column for comparison. The second or any multiple of magnets may be skipped as long as the next position used is plugged on both sides.

By plugging one of the magnets, a set-up is obtained corresponding to the perforation in the card. When the corresponding magnet is plugged on the opposite side of the unit, a similar set-up is obtained, thereby permitting a comparison.

Each unit may be plugged to give one of three comparisons. The three comparisons which may be obtained are an "equal" reading, a "high" reading and a "low" reading. This will permit the combination of cards coming under any one of the comparisons and the segregation of the remaining cards.

Each of the two units has a reading strip. Each magnet in the unit controls the position of the selection contact control lever which positions the selection contact springs on the reading strip, depending on the comparison of the digits being compared. If the number set-up on one side is "equal" to that on the other side, no motion is transmitted to the selection contact control lever, so that the selection contact springs give an even reading. If the number set-up on one side exceeds the number set-up on the other, motion is transmitted to the selection contact control lever so as to give a "high" reading. If the number set-up is lower on one side than the other, the selection contact control lever positions the selection contact springs so as to give a "low" reading.

Once each card cycle, a reading is sensed through this emitter strip and the various machine functions are controlled, depending on the nature of the operation.

As each card feeds by the sensing brushes, a set-up cam in each unit transmits motion to a set-up bail, which, in turn, operates a set-up ratchet for each magnet. The set-up ratchet has nine teeth and a stop tooth, and moves in synchronism with the card as it passes the brush reading stations. A set-up pawl controls the stopping of the set-up ratchet. The set-up pawl is normally held latched by the magnet armature and is tripped when a hole is sensed in the card. The set-up ratchet will then be stopped on the ratchet tooth corresponding to the hole sensed. The position of opposite set-up ratchets operate the selection contact control lever by means of a differential link and cause the selection contact spring to attain one of three positions -- "equal," "high," and "low."

Once each card cycle a cam transmits motion through a latch, which, in turn, operates on a restoring pawl, which will disengage the set-up pawl from the set-up ratchet, thereby insuring that all set-up ratchets are restored just prior to reading or sensing a new set-up. The restoring mechanism is magnetically controlled. The restoring magnets must receive an impulse each card cycle in order to restore the set-up ratchets. If no impulse is received to the restoring magnet, the previous set-up will remain.

The following conditions apply only to plugging setups using the basic setup. This involves only a small portion of the collator operations and is outlined

merely as an example. You will note that it is customary to refer to low readings only in this write-up, as it is the low reading rather than the high reading which is the source of control.

A low primary reading in the selector unit will cause primary feed operation.

Equal readings in both units cause the primary feed to operate.

An equal reading in the selector unit and a primary change in the sequence unit will result in both feeds operating with the M. S. and S. "OFF."

An equal reading in the selector unit and a primary change in the sequence unit will result in a secondary feed and a primary eject but no primary feed with the M. S. and S. "ON."

A low secondary reading in the selector unit causes the secondary feed to operate.

Fig. 10 is a cross-section of one of these units. Fig. 7 shows the sequence to follow when assembling a set-up ratchet assembly.

The units are adjusted as follows: (Fig. 8)

1. Bend the individual armatures so there will be .003 to .005 clearance between the armature and the core nearest the pivot point when the armature is attracted against the other core. Check with power.

2. The mounting brackets of the magnet assemblies should be so located between the side plates that the armatures "A" in the attracted position will have an unlatched clearance of .006 to .010. Fig. 8A. Bend the brass support for individual adjustment.

3. Move the entire magnet unit to the front or rear to provide .010 to .015 clearance between the stop pawls and the sector teeth when the stop pawl is latched. Fig. 8F. Individual adjustment can be obtained by moving each magnet to the front or rear. Check to be sure there is .010 to .014 clearance between stop pawl and end of armature when stop pawl is on high tooth of sector. Fig. 8B.

4. The adjusting screws "D" in the set-up bails should be adjusted to provide a uniform overlap of .030 to .040 of the stop pawls on the sectors at both ends of the unit on the corresponding line of index. It is then necessary to adjust screws "D" so the points of the restoring pawls "F" clear the latch "G" by .024 to .032 when the cam follower is on the highest point of the set-up cam "H." This last adjustment must be made in uniform steps on each of the screws "D" in order to maintain the proper uniform overlap. Fig. 8C.

5. With the set-up pawls engaging corresponding teeth of equal value in both the primary and secondary ratchets of each bank, adjust the selection contact spring assembly so that its contacts are on the center or equal position on the selection contact bar. With all sixteen positions set for equal readings, test by means of a test light, using a 1-watt neon bulb, to see that the circuit is complete throughout the entire length of the selection contact bar. This neon bulb should not be used for testing other circuits, as it will not indicate grounds.

6. After the set-up bails and magnet assemblies are properly adjusted, the set-up armature knockoff bail "I" should be adjusted by means of the eccentric studs



"J" in each end. This adjustment should be such that when the set-up bails are against the cam followers, which are at the same time resting on the low point of the set-up cams, the knockoff bail will have knocked the armatures off but be clearing them by from .002" to .006". Fig. 8D.

7. With the restoring pawl in its present position, and the restoring armature knockoff lever "K" at the end of its travel where it should knock off the armature, it should clear the armature by from .002" to .006". Fig. 8E.

8. Install the selector contact strips so the contacts will have an equal amount of travel from the center positions to the outer segments. The contact strips can be shifted by loosening their mounting screws.

To install the selector units, proceed as follows:

1. Set the machine to 8 on the index. (This will be 18° .)
2. Release the selector unit restoring magnet.
3. Turn the selector unit drive gear clockwise until the stop pawl overlaps the #8 tooth of the set-up ratchet .020".
4. Install the unit.
5. Adjust the unit adjusting screws (3, Fig 10) for a .002" wink of the drive gears.

CIRCUIT BREAKERS AND CR CAMS

The circuit breakers and CR cams are located in a unit on the left end of the machine. Looking at the unit from the front of the machine, the upper row of breakers are CR's 1, 2, 3 and 4, and the lower row CR's 5, 6, 7 and 8. The upper row, rear, are CB's 1, 2, 3 and 4. The circuit breakers are numbered from left to right on their respective shafts.

PURPOSE OF CONTACT POINTS

The CR contacts are continuously running as soon as the drive motor is operating.

CR-1--This contact controls the impulses to the feed clutches, the restoring magnets and the "Plug to C" plughubs, so that the various magnets will be energized at 201° .

CR-2--This contact controls the read-out impulses to the comparing units. It makes at 185° so that the various relays controlled from these units can be set up in time for CR-1 to send an impulse through their points to control feeding.

CR-3--This contact allows the circuits to be completed to the reading brushes during the reading portion of each card cycle. It is made for 9 to 1 reading time, broken at 0 reading time, and made again for X. It is broken at 0 time to eliminate the completion of circuits through 0 holes in the card to the magnets of the comparing units, as the sectors of these units do not have a 0 tooth.



CR-4--This contact controls the energization of the cycle delay relay (second cycle) R-16 in conjunction with the cycle delay (first cycle) R-33 B points.

CR-5--This contact closes after the various reading card levers have made to pick up the card lever contact relays and breaks before the card lever contacts open, thus eliminating arcing at the card lever contacts. These card lever contacts made and break each card cycle while cards are feeding.

CR-6--This contact completes a holding circuit for the start relay in conjunction with the R-17 AU points, to hold the relay up for one machine cycle when first starting the machine by depression of the start key, and also to hold the start relay during the time that CR-7 is open on each cycle, while cards are feeding.

CR-7--This contact emits an impulse each cycle to determine if the various card lever contacts or relays controlled by contacts are in the proper position to continue machine operation for another cycle. It also allows the start relay to be picked up only at a given time so that, when the start key is depressed, full timed impulses will be delivered to the feed clutches by CR-1.

CR-8--This contact controls the pick-up and drop-out of the feed interlock relay R-20, so that the various points controlling this relay will not be subject to a make or break arc.

PURPOSE OF PRIMARY COMMUTATORS

The primary commutators operate only under control of the primary feed clutch.

P-1--This commutator controls the hot 9 circuit after the cards have left the primary brushes No. 1 or No. 2. It is made only for the 9 impulse from the circuit breakers.

P-2--This commutator controls the holding circuit for the primary X selector, and a pick-up and holding circuit for the primary card lever contact No. 1 and No. 2 holding relays, so that these relays will be energized until after the beginning of the next primary cycle. It also acts as a holding means for the primary cycle delay (second cycle) relay R-16.

P-3--This commutator controls the circuit to the primary X selector relays HS-2 and R-11, so that these relays can be picked up only from an X hole in the card.

P-4--This commutator controls the holding circuits for the primary cycle delay (first cycle) R-33 and the error reset relay R-34, so that these relays will hold up until a primary cycle takes place.

PURPOSE OF SECONDARY COMMUTATORS

The secondary commutators operate only under control of the secondary feed clutch.

S-1--This commutator controls the hot 9 impulse after the cards have left the secondary brush station. It is made for the 9 impulse only of the circuit breakers.

S-2--This commutator controls the holding circuit for the secondary

X selector and a pick-up and holding circuit for the secondary card lever contact holding relays so that these relays will be energized after the beginning of the next secondary cycle.

S-3--This commutator controls the circuit to the secondary X selector relays HS-1 and R-10, so that these relays can be picked up only from an X hole in the card.

PURPOSE OF DUO RELAY CONTACTS

R-1 AL--The normally closed contacts establish, in conjunction with Pri. C.L.C. No. 1 (H) R-15 BU, and Pri. C.L.C. No. 2 (H) R-13 BL (normally open) as a test circuit for the continuation of operation for another cycle if cards are in the primary hopper.

The normally open contacts in conjunction with the secondary hopper R-3 BU and the Pri. C.L.C. No. 2 (H) R-13 BL (normally closed), shunt out the primary card lever controls when the secondary feed is being used alone.

R-1 AU--This contact in conjunction with Pri. C.L.C. No. 2 (H) R-12 BU, permits the energization of the start relay R-17 (PU No. 1) for three cycles through the start key No. 1 when using the primary feed. It requires three cycles to condition the primary contacts in series with start key No. 2.

R-1 BL--This contact in conjunction with Sec. hopper R-3 BL prevents energization of the restoring interlock relay R-21 without cards in either feed hopper, if the run-out key is depressed.

R-1 BU--This contact, in conjunction with Sec. hopper R-3 AL (normally open) and Sec. C.L.C. (H) R-9 AL (normally closed) shunts out the secondary card lever controls, when the primary feed is being used alone.

R-2 AL--This contact, when normally closed, permits a circuit to be completed to the primary feed magnet and the relay HS-3 when cards are inserted in the primary hopper. It should be noted that there are four card lever control contacts, one of which must be closed in order to energize the primary feed magnet. It should be noted that there are also four card positions in the primary feed, so that it is necessary to have a card in one of these positions in order to operate the primary feed.

R-2 AU--This contact, in conjunction with the normally closed side of Pri. C.L.C. No. 1, R-7 B, and the Pri. C.L.C. No. 2, R-6 B, permits the hot 9 circuits to be completed only during run-out cycles, and prevents these hot 9 circuits during run-in cycles.

R-2 B--This contact, when normally closed permits the automatic run-in circuits to be completed to the primary feed clutch and the secondary feed clutch. It prevents the completion of these circuits in the event that the secondary feed is being used alone.

R-3 AL--The normally closed contacts operate in conjunction with the Sec. C.L.C. (H) R-9 AL (normally open) as a test circuit for the continuation of operation for another cycle, if cards are in the secondary hopper.

The normally open contacts, in conjunction with Pri. hopper R-1 BU and Sec. C.L.C. (H) R-9 AL (normally closed) shunt out the secondary card lever controls when the primary feed is being used alone.



R-3 AU--This contact, in conjunction with Sec. C.L.C. (H) R-8 B, permits energization of the start relay R-17 (PU No. 1) for two cycles through the start key No. 1, when using the secondary feed. It requires two cycles to condition the secondary card lever contacts in series with the start key No. 2.

R-3 BL--This contact, in conjunction with Pri. hopper R-1 BL, prevents energization of the restoring interlock relay R-21 without cards in either hopper, if the run-out key is depressed.

R-3 BU--This contact, in conjunction with Pri. hopper R-1 AL, (normally open) and Pri. C.L.C. No. 2 (H) R-13 BL (normally closed) shunts out the Pri. card lever controls when the secondary feed is being used alone.

R-4 AL--This contact, when normally closed, permits a circuit to be completed to the secondary feed magnet when cards are inserted in the secondary hopper. It operates in conjunction with the other two card station contacts so that the secondary feed can operate only if cards are in one of the three positions in that feed.

R-4 B--This contact allows the hot 9 circuit to be completed to the secondary brushes only during run-out cycles of cards in the secondary feed. It prevents the hot 9 circuit from being completed during run-in cycles.

R-5 A--This contact allows the circuit breaker impulses to be sent to the secondary brushes only when cards are passing the secondary brush station.

R-5 B--This contact completes a circuit to pick up the Sec. C.L.C. (H) relays R-8 and R-9, when the secondary commutator No. 2 makes.

R-6 A--This contact completes a pick-up circuit to the Pri. C.L.C. No. 2 holding relays R-12 and R-13, when the primary commutator No. 2 makes.

R-6 B--The normally open points of this contact permit circuit breaker impulses to be delivered to the primary brushes No. 2 only when cards pass that brush station. The normally closed points, in conjunction with Pri. hopper R-2 AU, permit the hot 9 circuit to be completed after the last card leaves the primary brushes, and when open, prevent all impulses from the circuit breakers being sent to the primary brushes No. 1 when the last card passes the primary brushes No. 2.

R-7 A--This contact completes a pick-up circuit to the primary card lever contact No. 1 holding relays R-14 and R-15, when the primary commutator No. 2 makes.

R-7 B--The normally open points of this contact permit the circuit breaker impulses to be delivered to the primary brushes No. 1 only as cards pass that station. The normally closed points, in conjunction with Pri. hopper R-2 AU, permit the hot 9 circuits to be completed to the primary brushes No. 1 after the last card leaves, and when open, prevent all circuit breaker impulses from being sent to the primary brushes No. 2 when the first card passes the primary brushes No. 1.

R-8 AL--This contact completes a circuit, in conjunction with CR-8, to pick up the feed interlock relay R-20, after the last card has left the secondary feed. When open, while cards are feeding, it prevents energization of this feed interlock relay.

R-8 AU--This contact completes the holding circuit for the Sec. C.L.C. (H) relays R-8 and R-9, after they have been picked up by a circuit through R-5 B and

the secondary commutator No. 2.

R-8 BL--This contact, in conjunction with the secondary hopper R-3 AU, permits energization of the start relay (R-17 pick-up No. 1) for only two cycles, through the start key No. 1, when using the secondary feed alone.

R-9 AL--This normally closed contact, in conjunction with Pri. hopper R-1 BU and Sec. hopper R-3 AL (normally open, permits CR-7 test circuits to be completed around the Sec. C.L.C. relay points when the primary feed is being used alone. The normally open points, in conjunction with the Sec. hopper R-3 AL (normally closed) establish a test circuit for the continuation of operation for another cycle, if cards are in the secondary brush station.

R-9 B--The normally closed points of this contact establish the circuit to the secondary feed magnets for the first two cycles when cards are placed in the secondary hopper at the beginning of a run, regardless of the plugging or basic set-up switch arrangement. This insures the feeding of the first card past the secondary brushes. The normally open point establishes a circuit to the secondary feed clutch magnet at any time that a card is in a position just past the secondary brushes. See R-4 A.

R-10 A and R-10 B--These contacts act as one transfer point to make or break a circuit between the common, X and No X hubs of the secondary X selector.

R-11 A and R-11 B--These contacts act as one transfer point to make or break a circuit between the common, X and No X hubs of the primary X selector.

R-12 AL--This contact permits a circuit through the basic set-up switch "E" and Pri. eject plughubs to be completed to the eject feed clutch magnet, only if a card is at the eject station.

R-12 AU--The normally closed point of this contact permits circuits to be completed to the primary feed clutch for three cycles when first starting a run of cards. At the end of the third cycle this contact opens, and thereafter the energization of the primary feed clutch magnet is under the control of the basic set-up switch "P" or auxiliary plugging to the plughubs "Primary Feed." The normally open points complete a circuit to the primary feed magnet at any time when a card is in the eject station. See R-2 AL.

R-12 BL--This contact, in conjunction with the Pri. C.L.C. No. 1 (H) R-14 AL, establishes a circuit to the feed interlock relay R-20 after the last card leaves the primary feed.

R-12 BU--This contact, in conjunction with Pri. hopper R-1 AU, permits energization of the start relay R-17 (pick-up No. 1) for only three cycles through the start key No. 1 when using the primary feed alone, or in conjunction with the secondary feed.

R-13 AL--This point acts as a holding means for the Pri. C.L.C. No. 2 (H) R-12 and R-13.

R-13 AU--This point, in conjunction with the Pri. C.L.C. No. 1(H) R-14 BU, establishes a circuit for running cards out of the secondary feed during operations in which the secondary operates from conditions established between the primary brushes No. 1 and No. 2. An example of this type of work would be the feeding of a



blank card ahead of each primary group, in which case the secondary feed is operated by a high second card reading in the sequence unit. After the last card leaves the primary feed it is impossible to secure a high second card reading, and thereafter the R-13 AU and R-14 BU points are used to feed the secondary.

R-13 BL--The normally closed points of this contact work in conjunction with the secondary hopper R-3BU and the primary hopper R-1 AL (normally open) to complete the CR-7 test circuit when there are no cards in the primary feed. The normally open points work in conjunction with Pri. C.L.C. No. 1 (H) R-15 BU, and the Pri. hopper R-1 AL (normally closed) to establish the test circuit for CR-7 when cards are feeding in the primary feed.

R-14 AL--This contact, in conjunction with the Pri. C.L.C. No. 2 (H) R-12 BL, prevents energization of the feed interlock relay during the third cycle of the primary feed. It permits CR-8 to complete a circuit to the feed interlock relay R-20 after the cards have left the primary feed.

R-14 AU--This contact permits a circuit to be completed to the primary feed clutch magnet when a card has just passed the primary brushes No. 1. See R-2 AL.

R-14 BL--This contact opens during the second cycle of the primary feed and prevents energization of the unit clearing R-18 and R-19, on the third cycle. This is necessary inasmuch as the secondary feed is not operating on the third cycle of the primary, and the secondary restoring magnet should not be energized.

R-14 BU--See R-13 AU.

R-15 A--This contact allows an equal reading in the selector unit to operate the secondary feed clutch magnet after the last card passes the primary brushes No. 2. This is necessary in the event that the last card in the primary feed is punched 9's, which condition would eliminate the high secondary card reading as the last card passes the secondary brushes No. 2. The normally open points permit an equal condition in the sequence unit and an equal condition in the selector unit to operate the primary feed clutch normally.

R-15 BL--This contact serves as a holding means for the Pri. C.L.C. No. 1 (H) R-14 and R-15.

R-15 BU--This contact operates in conjunction with the primary hopper R-1 AL, (normally closed) and the Pri. C.L.C. No. 2 (H) R-13 BL, (Normally open) to establish test circuit to CR-7 when cards are present in the primary feed.

R-16 A--This contact acts as a holding means for the Pri. cycle delay (second cycle) R-16.

R-16 B--This contact completes the circuit between the primary cycle delay plughubs for control of various cycle delay operations.

R-17 AL--This contact serves as a holding circuit during the time that CR-7 is made during each card cycle, providing that the various card lever contacts are in the proper position.

R-17 AU--This contact acts as a holding means for the start relay (pick-up No. 2) R-17, through CR-6.

R-17 B--This contact controls all circuits to the comparing units read-out circuits, and to the feed clutch magnets, restoring magnets, selection magnets, etc., allowing these circuits to be completed only when the start relay is energized.

R-18 A--This contact prevents the pick-up of the restoring interlock relay R-21 until the third cycle of the machine, as this contact does not make until after CR-1 makes and breaks for the second cycle.

R-18 B--This contact acts as a holding contact for the unit clearing R-18 and R-19, in parallel with the start relay (pick-up No. 2) R-17.

R-19 AL, R-19 AU and R-19 BL--These three points insure the clearing of the comparing units at the beginning of the run, as they are made for the first two cycles.

R-20 A and R-20 B--These two contacts are used to connect the three readings from the selector unit, after the last card leaves either feed, to effect selection of any cards punched 9's. Selection of any other card could be effected by a low reading, caused when the hot 9 circuit functions in the opposite feed.

R-21A--This contact establishes a holding circuit for the restoring interlock relay R-21 through the run-out key No. 2 contact.

R-21 B--This contact renders the start key contact No. 1 inoperative, after the run-in cycles. If, during a run, a jam occurs at one of the reading stations, allowing the Pri. C.L.C. No. 2 (H) or the Sec. C.L.C. (H) R-8 B to close, it is necessary to depress the run-out key.

R-22 A--This contact causes the eject clutch magnet to operate on a low primary condition in the selector unit when the basic set-up switches are "ON."

R-22 B--This contact causes the primary feed magnet and associated circuits to be energized on a low primary reading in the selector unit when the basic set-up switches are "ON."

R-23 A--This contact causes the eject feed magnet to be energized on an equal condition in the selector unit when the basic set-up switches are "ON." It should be noticed that this point also operates the primary feed clutch on an equal condition when the Multiple Sec. with Selection switch is "OFF."

R-23 B--This contact, in conjunction with Pri. C.L.C. No. 1 (H) R-15 A (normally open) and equal second primary R-26 A, operates the primary feed magnet on an equal condition in both comparing units. It operates in conjunction with the equal second primary R-26 B and high second primary R-25, or low second primary R-27, to operate the secondary feed magnet with an equal condition in the selector unit and a high or low condition in the sequence unit, when basic set-up switches are "ON." See R-15A.

R-24--This contact causes the secondary feed magnet to be energized on a low secondary reading in the selector unit, when basic set-up switches are "ON."

R-25--See R-23 B.

R-26 A--See R-23 B.

R-26 B--This contact prevents operation of the secondary feed magnet when

merging with the use of only the selector unit, on an equal condition in the selector unit and a high second card reading in the sequence unit, when the primary change switch is "OFF."

R-27--See R-23 B.

R-28 A and R-28 B through R-32 A and R-32 B--These contacts act as transfer contacts for the various selectors to make or break circuits between the "C" hub and the "X" and "No X" hubs.

R-33 A--This contact establishes a holding circuit for the primary cycle delay (first cycle) R-33.

R-33 B--This contact establishes a pick-up circuit for the primary cycle delay (second cycle) R-16 in conjunction with CR-4 to delay the operation of R-16 one cycle.

R-34 AL--This point prevents the re-energization of the error pick-up relays HS-4 and R-35 after the error re-set key has been depressed.

R-34 AU--This contact provides a holding circuit for the error re-set relay R-34.

R-34 B--This contact drops out the error hold relay R-35 when the error re-set key is depressed.

R-35A--This contact establishes a holding circuit for the error holding relay R-35.

R-35 B--This contact opens the CR-7 test circuit to the start relay (pick-up No. 2) R-17 when the error circuit is energized.

PURPOSE OF HS RELAY CONTACTS

HS-1--This contact establishes a holding circuit for the secondary X selector relays HS-1 and R-10. A high speed relay is needed to sense the X hole in the card.

HS-2--This contact establishes a holding circuit for the primary X selector relays HS-2 and R-11. A high speed relay is needed to sense the X hole in the card.

HS-3--This contact causes the eject feed magnet to be energized on each primary cycle, so that the eject mechanism is operating to receive a card from the primary feed.

HS-4--This contact opens the various feed clutch circuits when an error occurs so that the machine will stop on the cycle in which the error was sensed.

PURPOSE OF CARD LEVER CONTACTS

The purpose of all card lever contacts is obvious, with the exception, perhaps, of the two following:

The primary machine card lever contact and the secondary machine card lever contact cause the respective feed clutch circuits to operate on the cycle in which a card is ready to enter the primary brushes No. 1 and the secondary brushes, respectively, in the event that a single card is inserted in either feed.

The pocket stop contact is a mercury type switch, and is used to break the start relay R-17 (pick-up No. 2) test circuit when a pocket is filled to capacity.

CIRCUITS Fig. 38.

All circuits on the Electric Punched Card Collating Machine operate on 40 volts D.C. The 40 volt current is furnished by a motor generator, which is a separate unit in the machine. A separate drive motor is provided to operate the machine mechanically. The generator and the motor can be obtained in any voltage and frequency so that the machine will operate from any commercial current source.

The circuits to the generator and drive motor are so arranged that when the sentinel switch is turned "ON" the motor generator will start first, and after the voltage in the generator has built up to between 25 and 30 volts, a heavy duty relay is operated which closes its points and completes the circuit to the drive motor.

This method of starting has two distinct advantages: 1. The starting current of the machine is reduced, as the two units do not start at the same time. 2. Machine operation cannot be started until the generator voltage is at the proper point.

During the study of these circuits, from time to time it will be noted that various parallel circuits are completed. However, it should be definitely understood that the additional parallel circuits have no bearing on the function of the machine at that time and will be explained in detail at a later point in the description.

The circuits for the motor generator and drive motor are as follows:

1. Motor Generator Motor Circuit -- When the sentinel switch is closed, the circuit is completed as follows: Attachment cord, post 3, blade of sentinel switch, post 5, motor side of motor generator, post 8, blade of sentinel switch, thermal element of sentinel switch, post 1 to the other side of the line.

2. Heavy Duty Relay -- When the voltage builds up to between 25 and 30 volts, the heavy duty relay attracts its armature. The circuit is as follows: Line terminal of motor generator, 3 amp. fuse, coil of heavy duty relay, 3 amp. fuse, generator post A.

3. Drive Motor -- The points of the heavy duty relay, when closed, complete a circuit, from the attachment cord to post 3, sentinel switch, post 5, points of heavy duty relay, post 6, drive motor, post 8, sentinel switch, post 1 to other side of the line.

It will be noticed that the test lamp outlet is hot at all times, if the attachment cord is plugged to the commercial supply.

40 Volt Machine Circuits -- In order to facilitate the study and description of the circuits, various basic set-ups will be covered in detail, both as to circuit description and machine cycles. Reference will be made to both plugboard set-ups and cycle analysis charts.

When the generator voltage builds up after the machine has been turned on, and before cards are inserted in either hopper, circuits will be completed to the primary hopper relays Nos. 1 and 2 and to the secondary hopper relays Nos. 3 and 4.



4. Primary Hopper Relays -- This circuit is as follows: Post 6, primary hopper relays Nos. 1 and 2, primary hopper contact normally closed, to post 3.

5. Secondary Hopper Relays -- This circuit is as follows: Post 6, secondary hopper relays 3 and 4, secondary hopper contact normally closed, to post 3.

Any time that cards are placed in either feed hopper, the hopper contacts open, causing these relays to drop. As the last card leaves the hopper, the hopper contacts make at approximately 57° , again picking up their respective relays.

SINGLE FEED OPERATIONS - SEQUENCE CHECKING

Consideration is given first to simple operations of the machine in which only one feed is used, for example, a simple sequence check in which the primary feed only is used. The plugging for this operation is shown in plug-board set-up, Fig. #12. The sequence unit is plugged to the primary brushes and primary sequence brushes so that a comparison is made between the cards as they pass these two stations in the primary feed. As long as an equal condition, or a high second primary condition exists, the cards are in proper sequence. When a low primary condition exists in the sequence unit, it means that the card or cards are out of sequence numerically. Cards are placed in the primary hopper face down, "9" edge first.

Depressing the start key will cause start relay R-17 to become energized, and the machine to take one cycle.

6. Start Relay R-17 Pick-up -- When the start key is depressed, a circuit is completed from start relay R-17 (PU No. 1), Pri. C.L.C. #2 (H) R-12BU, Pri. hopper R-1AU normally closed, one side of secondary hopper R-3AU, restoring interlock R-21B normally closed, start key contact No. 1, stop key, CR-7 to post 9. This circuit can only be completed between 123° and 168° under control of CR-7. This insures a full-time impulse to all feed clutches, through CR-1, which makes from 201° to 221° .

7. Start Relay R-17 Holding -- As soon as R-17AU points close, a holding circuit is established through start relay R-17 (PU No. 2), start relay R-17AU, CR-6, one side of CR-7, to post 9. R-17 remains energized until 128° of the following machine cycle, so that the R-17B point will complete the circuits to the feed clutches when CR-1 makes.

8. Primary Feed Clutch Magnet -- The "Plug to C" hubs will be hot each cycle when CR-1 makes at 201° , if the 17-B points are closed, and, therefore, a circuit is completed to the primary feed clutch magnet as follows: Post 8, primary feed clutch magnet, one side of Pri. C.L.C. #1 R-14AU (H), primary hopper R-2AL, one side of Pri. C.L.C. #1, (H) R-14AU, one side of Pri. C.L.C. #2 (H) R-12AU, plug hubs "Primary Feed," by plugwire to plug hubs "Plug to C," error stop HS-4, CR-1, start relay 17-B, post 11.

9. Eject Feed Clutch Magnet -- Eject interlock relay HS-3 is wired in parallel with the primary feed clutch magnet so that it is energized each time that the primary feed clutch magnet receives an impulse. The point of eject interlock relay HS-3 is used to energize the eject feed clutch magnet. The circuit is as follows: Post 8, eject feed clutch magnet, one side of Pri. C.L.C. #2 (H)



R-12AL, eject interlock relay HS-3, one side of low Pri. R-22A, error stop relay HS-4, CR-1, start relay R-17B to post 11.

By referring to plugboard set-up Fig. No. 12, it will be noticed that the restoring magnets of the sequence unit are wired to the restoring hubs. This places the restoring magnets in parallel with the primary feed clutch magnet so that these restoring magnets will receive an impulse on every primary cycle to enable a new reading to be placed in the sequence unit.

On this cycle the first primary card is advanced to the primary sequence brushes, closing the primary machine card lever contact. See Fig. No. 12-A. This contact has no effect at the present time, because the primary hopper R-2AL points are made. At the end of the first cycle the machine will stop unless the start key is held down, and it is necessary to depress the start key a second time, picking up the start relay pick-up No. 1 through the start key contacts No. 1. This will cause the primary feed clutch magnet and eject feed clutch magnets to receive a second impulse in exactly the same manner as before, causing the second primary card to be advanced from the primary hopper and the first primary card to be advanced past the primary sequence brushes. See Fig. No. 13. The first card, as it passes the primary sequence brushes, will close the primary reading C.L.C. No. 1, picking up the Pri. C.L.C. #1 R-7.

10. Pri. C.L.C. No. 1 R-7 Pick-up Circuit -- This circuit is as follows: Post 6, R-7 coil, Pri. Reading C.L.C. #1 contact, CR-5 to post 3.

Pri. C.L.C. #1 R-7B points will be transferred as the card passes the primary sequence brushes so that circuits can be completed through the holes in the card to energize the set-up magnets in the sequence units.

11. Sequence Unit Set-up Magnet Circuit -- This circuit is as follows: Post 4, sequence unit set-up magnets, plug hubs "Pri. Sequence No. 2," plugwire to plug hubs "Pri. Sequence Brushes," primary sequence brushes, contact roll, common brush, Pri. C.L.C. #1 R-7B, one side of Pri. C.L.C. #2 R-6B, break circuit breakers Nos. 3 and 4, make circuit breakers Nos. 1 and 2, CR-3 to post 1.

At the end of the second machine cycle, it will again be necessary to depress the start key, inasmuch as a test circuit for the start relay is not yet complete, as the first card has not passed the primary brushes. The start relay (PU No. 1) R-17, the primary feed magnet contact, and the eject magnet will be energized in the same manner as explained previously, and the machine will take a third cycle. See Fig. No. 14. During the third cycle, the first card passes the primary brushes. Pri. reading C.L.C. No. 2 is closed, picking up Pri. C.L.C. No. 2 R-6, transferring the R-6B points so that circuits are completed through the primary brushes to the primary sequence No. 1 set-up magnets.

On the third cycle the second card passes the primary sequence brushes, setting up the reading in the primary sequence set-up magnets No. 2.

12. Pri. C.L.C. #1 Holding Relays -- During the second cycle of the primary feed, Pri. C.L.C. No. 1 holding relays R-14 and R-15 are picked up when primary commutator No. 2 makes, through Pri. C.L.C. No. 1 R-7A points, by the following circuit: Post 6, Pri. C.L.C. #1 holding R-14 and R-15, R-7A points, one side of R-6A points, primary commutator No. 2, one side of secondary commutator No. 2 to post 5.

A holding circuit is established for these relays through the R-15BL points until primary commutator #2 breaks at 236° of the following cycle. It must be remembered at all times that the latching point of the primary feed and secondary feed is 226°, and that of the eject clutch 235°.

13. Pri. C.L.C. No. 2 Holding Relays -- On the third cycle R-12 and R-13 relays pick up by a circuit similar to No. 12 and hold up until the primary commutator No. 2 breaks on the following cycle.

At this point it is well to note that the C.L.C. relays are energized only while the cards are passing the brushes, and that the C.L.C. holding relays remain energized until after the beginning of the next cycle. The card lever contact relays provide a means of circuit control as the card passes the brushes. The card lever contact holding relays provide a means of circuit control while the particular feed is standing still, if a card passed the respective brush station on the previous cycle.

After the 3rd cycle the machine will continue to operate automatically until an error occurs, the cards fail to feed, or all the cards leave the hopper. Start relay pick-up #2 R-17 is held up through the R-17AL points, the various card lever contact relays points and the CR-7 cam, while CR-6 is open.

14. Start Relay (Pick-up No. 2) R-17 Test Circuit -- This circuit is as follows: Start Relay (Pick-up #2) R-17 coil, R-17AL, pocket stop contact, secondary hopper R-3AL (normally open), primary hopper R-1BU (normally closed), R-9 AL (normally closed), R-1 AL (normally closed) Pri. C.L.C. #1 (H) R-15BU, Pri. C.L.C. #2 (H) R-13 BL (normally open), error stop R-35B, stop key, CR-7, post 9. The CR-7 cam emits a test impulse each cycle to determine if the conditions in the machine are proper for the continuation of another cycle. It will be noticed that the secondary card lever controls are shunted, and that the circuit was traced through the card lever controls of the primary feed. The opening of any one of these contacts will cause the machine to stop, as the start relay R-17 will drop when CR-6 breaks at 128°.

The start key contact #2, when depressed, causes the machine to function again, only if conditions within the machine have been corrected so that it should operate. For example, if cards run out of the primary feed, the machine will stop, and can be started again when the start key contact #2 is closed, only after cards have been inserted in the primary feed. However, if a jam occurs at one of the reading stations, the start key contact #2 will not pick up relay R-17, and it is then necessary to depress the run-out key. Whenever the run-out key is depressed, it is necessary to clear all cards out of the machine and replace the remaining cards in the feed before again depressing the start key.

The start key contact #1 is electrically inoperative after the 3rd cycle, as the restoring interlock relay R-21 picks up during the 3rd cycle, opening the restoring interlock point R-21B. The start key contact #1 controls the pick-up of R-17 during run-in cycles, the start key contact #2 controls the pick-up of R-17 during a run, if the machine is stopped and again started, provided conditions are such that it should operate, and the run-out key, as will be explained later, is used to run the last cards out of the machine.

15. Restoring Interlock R-21 Pick-up -- This circuit is as follows:



Restoring interlock R-21 pick-up coil, unit clearing R-18A, Pri. hopper R-1BL, one side of interlock relay HS-3, one side of low primary R-22A, error stop relay HS-4, CR-1, start relay R-17B, to post 11.

A holding circuit is established for restoring interlock relay R-21, through the R-21A points and the normally closed contacts of the run-out key #2. The restoring interlock relay does not pick up during the first two cycles as the unit clearing R-18A point is open.

The unit clearing relays R-18 and R-19 are picked up for the first two cycles during a run, in parallel with the start relay (pick-up #1) R-17 to insure the clearing out of the comparing units at the beginning of a run, and to prevent the pick-up of the restoring interlock relay. The unit clearing relays R-18 and R-19 do not pick up after the second cycle, due to the fact that Pri. C.L.C. #1 (H) R-14BL point is open. In this particular job the restoring magnets receive impulses from other sources during the run-in. However, the unit clearing relays are necessary for restoring purposes on other set-ups.

During the 4th cycle, the second #36 card passes the primary brushes, card 34 passes the primary sequence brushes. See Fig. No. 15. This, of course, will cause a low second primary reading in the sequence unit, and the machine will stop. The error stop circuit functions in the following manner:

16. Error Pick-up HS-4 and R-35 -- This circuit is as follows: Post 14, HS-4 and R-35, error reset R-34AL, plugboard hubs "Error Pick-up," plugwire to "Low Second Primary" hubs, sequence unit contacts, primary sequence control input, CR-2, one side of CR-1, start relay R-17B, post 11.

The energization of the HS-4 relay will open the error stop point HS-4 in the primary feed clutch circuit. This point opens at approximately 185°, and the impulse through it comes at 201°, so that ample time is provided for opening of the feed circuit before CR-1 makes.

17. Error Hold -- This circuit is as follows: Post 14, error hold relay R-35, R-35A, error reset R-34B, post 15.

Error stop R-35B point opens, and breaks the CR-7 test circuit, so that the start relay R-17 drops. It is necessary to drop the 17 relay so that the machine will not start automatically after the error reset key is depressed.

The error lamp is wired in parallel with the error hold R-35 coil, and will glow, signalling the operator that an error has occurred.

It is now necessary to depress the error reset key to pick up the error reset relay R-34.

18. Error Reset R-34 Pick-up -- This circuit is as follows: Post 14, error reset R-34 coil, error reset key, post 13.

The holding circuit is established for the error reset relay through the R-34AU points and the primary commutator #4.

Error reset R-34B points open, dropping R-35 relay so that the machine can be started by depression of the start key, by a circuit to pick up R-17 through the start key contacts #2. When checking the cards to determine the nature of

the error, several cards should be checked, as a single card, or a group of cards, may be out of sequence.

After the error is checked, and the start key again depressed, the machine will continue to operate until card #42 leaves the primary hopper. At 57° on that cycle the primary hopper contact makes and picks up R-1, transferring the primary hopper R-1AL points so that the CR-7 test circuit is not complete at 123°, and the start relay drops, opening the R-17B point, stopping the machine.

It is now necessary to depress the run-out key to pick up the start relay through the run-out key contact #1, as the start key contacts #1 and #2 are electrically inoperative.

As the last card passes the primary brushes a hot 9 circuit is completed to the primary sequence brushes, causing 9's to be read into the sequence unit. This creates a high second card reading, or an equal reading in the event that the last card past the primary brushes is punched all 9's.

19. Primary Brush #1 Hot 9 Circuit -- This circuit is as follows: Post 4, Pri. Sequence #2 Magnets, plugboard hubs "Pri. Seq. #2," plugwire to plugboard hubs "Pri. Seq. Brushes," Pri. Seq. Brushes, contact roll, common brush, Pri. C.L.C. #1 R-7B (normally closed), Pri. Hopper R-2AU, Pri. commutator #1, break circuit breakers #3 and #4, make circuit breakers #1 and #2, CR-3 to post 1.

As the last card leaves the machine, a similar circuit will be completed through the primary brushes and the Pri. Seq. Magnets #1, causing 9's to be set up in the lower half of the sequence unit.

After the last card leaves the primary feed, the feed will stop, even though the run-out key is held down, due to the fact that the card lever contacts controlling the primary feed clutch magnet and the eject feed clutch magnet are open.

By removal of the plugwire to the "Error Stop" plughubs, and insertion of a plugwire to the "Pri. Select" hubs, the machine will select a card when an error occurs. By insertion of a plugwire to the secondary feed and placing of tab cards in the secondary feed, a tab card can be inserted ahead of each card in error.

By placing a plugwire from the "Equal Second Primary" hubs to the "Error Stop" hubs, the machine will stop whenever a duplicate card appears. This application is useful in checking files in which no duplicate cards should exist.

SINGLE FEED OPERATIONS - X CARD SELECTION

All start and running circuits are the same as those explained under Sequence Checking.

For selection of X punched cards in the primary feed the plugboard will be set up as shown in Fig. No. 16. It will be noticed that the Pri. X Pick-up is wired to the primary brushes. This causes the Pri. X Circuit to function when an X punched card passes the brushes, as follows:

20. Pri. X Selector Pick-up -- This circuit is as follows: Post 6,



Pri. X Selector Relays HS-2 and R-11, Pri. Commutator #3, plugboard hubs "Pri. X PU," plugwire to primary brushes, contact roll, common brush, Pri. C.L.C. #2 R-6B, break circuit breakers #3 and #4, make circuit breakers #1 and #2, CR-3, post 1.

A holding circuit is established for the primary X selector relays HS-2 and R-11 through the HS-2 points and the primary commutator #2.

At 201° a circuit is completed through the points of the primary X selector to energize the primary select magnet.

21. Pri. Select Magnet -- This circuit is as follows: Post 12, Pri. select magnet, plughubs "Pri. Select Magnet," plugwire to Pri. X "X" hub, Pri. X selector R-11A, Pri. X "C" hub, plugwire to plughubs "Plug to C," error stop HS-4, CR-1, start relay R-17B, post 11.

This causes the X punched cards to be deposited in the primary select pocket. "No X" cards can be selected by plugging the select magnet through the "No X" side of the Pri. X Selector.

SINGLE FEED OPERATIONS - LAST CARD SELECTION

The last card of each group can be selected by inserting a plugwire from the plughubs "High Second Primary" to the plughubs "Primary Selected," See Fig. No. 17A. In this operation a high second primary reading, which will occur as the last card of a certain group passes the primary brushes, and the first card of the next group passes the primary sequence brushes, will cause the primary select magnet to be energized.

SINGLE FEED OPERATIONS - FIRST CARD SELECTION

The first card following the last card of a preceding group will be selected by plugging as shown in Fig. No. 17B. In this arrangement, the cycle delay circuit is used, and functions as follows:

21. Primary Cycle Delay Pick-up -- This circuit is as follows: Post 14, Pri. Cycle Delay (first cycle) R-33 PU, plugboard hubs "Pri. Cycle Delay Pick-up," plugwire to plughubs "High Second Primary," sequence unit contacts, primary sequence control input, CR-2, start relay R-17B, post 11. This circuit is completed at 185° on the cycle that the card #85 passes the primary sequence brushes. See Fig. No. 18.

As the card #85 is the one to be selected, the select magnet cannot be energized on this cycle, but must be energized on the following cycle. This is accomplished through the cycle delay points. The primary cycle relay (first cycle) R-33 is held up by a circuit through the R-33 A and primary commutator #4, until this commutator breaks at 40° on the following cycle.

The primary cycle delay (second cycle) R-16 picks up at 355° through the cycle delay (first cycle) R-33B points, and holds up through its 16A point and primary commutator #2 until 236° of the third cycle. At the end of the cycle during which card #85 passes the primary brushes, a circuit is completed through the primary cycle delay R-16B points, to energize the primary select magnet.

22. Primary Select Magnet Through Cycle Delay -- This circuit is as follows: Post 12, primary select magnet, plughubs "Pri. Select," plugwire to plughubs "Pri. Cycle Delay," primary cycle delay R-16B, plughubs "Pri. Cycle Delay," plugwire to plughubs "Plug to C," error stop HS-4, CR-1, start relay R-17B, to post 11.

The primary cycle delay circuit, as the name implies, provides a hold-over means for one primary cycle, so that a comparing unit reading taken during a primary cycle can be used on the following cycle.

SINGLE FEED OPERATIONS - SINGLE CARD SELECTION

Plugging for single card selection is shown in Fig. No. 17C. Selection in this case is effected by means of successive high second primary readings. The first high second primary reading picks up the primary cycle delay circuit, and the second or more high second primary readings in succession cause a circuit to be completed through the points of the primary cycle delay. Fig. No. 19 shows an example of this type of operation, where card #111 will be selected, as it is a single card.

SINGLE FEED OPERATIONS - SECONDARY X CARD SELECTION

X or No X card selection can be effected in the secondary feed by plugging the board as shown dotted in Fig. No. 16. With this arrangement the secondary feed operates, and selection of the X or No X punched cards takes place in a manner similar to that described in "X Selection" in the Primary Feed.

TWO FEED OPERATIONS - MERGING WITHOUT SELECTION

The machine plugboard will be set up as shown in plugboard Fig. No. 20, and cards will be placed in the hopper as shown in Fig. No. 19.

On the first machine cycle, card #11 in the secondary feed moves up to the secondary brushes, and card #11 in the primary feed moves up to the primary sequence brushes. See Fig. No. 22.

The start relay R-17 is picked up in the same manner as explained under Single Feed Operations in Circuit #6. The start relay is also held up as explained previously in Circuit #7.

23. Primary Feed Clutch -- This circuit is as follows: Post 8 primary feed magnet, one side of Pri. C.L.C. #1 (H) R-14AU, Pri. hopper R-2AL (normally closed), one side of Pri. C.L.C. #1 (H) R-14AU, Pri. C.L.C. #2 (H) R-12AU normally closed, Pri. hopper R-2B (normally closed), one side of Pri. hopper R-1BL, one side of eject interlock HS-3, one side of low Pri. R-22A, error stop HS-4, CR-1 when it makes at 201^o, start relay R-17B, to post 11.

24. Secondary Feed Clutch -- This circuit is as follows: Post 8, Sec. feed magnet, Sec. hopper R-4A (normally closed), Sec. C.L.C. (H) R-9BL (normally closed), one side of Pri. Mach. C.L.C., one side of Pri. hopper R-2AL, one side of Pri. C.L.C. #1 (H) R-14AU. to post 11, the same as in previous circuit.

The eject feed magnet will be energized through the HS-3 points, as explained in Circuit #9.

By referring to the plugboard chart, Fig. No. 20, it will be noticed that the restoring magnets for the primary side of the selector unit and for both sides of the sequence unit are plugged to the restoring hubs. This plugging places the restoring magnets in parallel with the primary feed clutch and causes restoration of the sectors under control of these respective magnets each time the primary feed magnet receives an impulse. It will also be noticed that the restoring magnet for the secondary side of the selector unit is in parallel with the secondary feed clutch, and, therefore, will cause restoration of this unit, each time that the secondary feed receives an impulse.

During the first machine cycle, the Pri. Machine C.L.C. and the Sec. Machine C.L.C. close. It will be noted that these contacts are in parallel with previous circuits and function only if a single card is placed in either feed.

It is necessary to depress the start key a second time, after which circuits are completed to operate the machine for the second cycle, moving the cards into position as shown in Fig. No. 23. The primary and secondary feed clutch circuits for this second cycle are identical to those for the first. During the second cycle, card #11 passes the secondary brushes, reading an 11 into the secondary side of the selector unit. Likewise, card #11 in the primary feed passes the primary sequence brushes, causing a set-up in the sequence brush side of the sequence unit. However, these readings have no significance at the present time. It should be noted that 9 through 1 punchings are the only positions that actuate the stop pawls of the comparing units.

The brush read-in circuits are similar to that traced in Circuit #11.

During the second machine cycle, the secondary reading card lever contact, in conjunction with CR-5, completes a circuit to the Sec. C.L.C. relay R-5. In like manner, Pri. Read C.L.C. No. 1 completes a circuit to Pri. C.L.C. No. 1, R-7.

The energization of the Sec. C.L.C. R-5 allows the R-5A points to complete reading circuits to the secondary brushes and in like manner the Pri. C.L.C. No. 1, R-7B, completes reading circuits to the primary brushes No. 1. During the second cycle, Sec. C.L.C. holding relays R-8 and R-9 are energized when the secondary commutator No. 2 makes at 34° by a circuit through the 5B points. The R-8 and R-9 relays remain up after the 5B points open at 188° by means of a holding circuit through the R-8AU points and the secondary commutator No. 2 until 236° of the following cycle. In a like manner the Pri. C.L.C. No. 1 holding relays R-14 and R-15 pick up through R-7A and the primary commutator No. 2 and hold up through R-15BL points until the primary commutator No. 2 breaks at 236° of the next primary cycle.

It is necessary to depress the start key again in order to obtain the third machine cycle, after which the machine will continue to run automatically until the cards have left either feed. On the third cycle, (See Fig. No. 24) the secondary feed does not operate due to the fact that the Sec. C.L. (H) R-9BL point transfers during the second cycle. The circuit to the primary feed magnet is identical to that described in cycle No. 1. After the start key is depressed the third time, the start key relay pick-up #2 R-17 is held up either through the R-17AL or the R-17AU points. The circuit through the R-17AL points is similar to circuit #14, except that the points controlled by the secondary feed card levers are now introduced in the circuit. The completion of this test circuit through the R-17AL points means that cards are feeding properly in both feeds, and that the machine can operate for another cycle.

As the card punched 11 in the primary feed passes the primary brushes, the Pri. Read C.L.C. #2, in conjunction with CR-5, causes the Pri. C.L.C. #2 R-6 to be energized, transferring the Pri. C.L.C. #2 R-6B points so that the reading impulses can be sent to the primary brushes. This causes the 11 punched in the card to read into the primary side of the selector unit. The card punched 12 passes the primary sequence brushes, and a 12 is entered into the sequence brush side of the sequence unit.

It is possible to enter these new readings into the comparing units due to the fact that the respective restoring magnets have received impulses at the same time that the primary feed clutch was energized, as was mentioned in previous explanation. It can be observed, by referring to Fig. No. 24, that at the end of the third cycle an equal reading exists in the selector unit with a high second primary reading in the sequence unit. Therefore, when CR-2 makes at 185° of the third cycle, circuits are completed through the contacts of the comparing units to pick up equal relay R-23 from the selector unit and equal second primary R-26 from the sequence unit.

Inasmuch as the basic set-up switches "E," "P" and "S" are in the "ON" position, closure of the R-23A point completes circuits to energize the eject magnet and the primary feed magnet for the fourth cycle. The primary feed clutch magnet can be energized for the 4th cycle through the Pri. C.L.C. #2 (H) R-12AU (Normally open), as this relay transferred during the third cycle.

25. Eject Feed Magnet Equal (Selector Unit) -- This circuit is as follows: Post 8, eject feed magnet, Pri. C.L.C. #2 (H) R-12AL, basic set-up switch "E" "ON," one side of low primary R-22A, equal R-23A, error stop relay HS-4, CR-1, start relay R-17B, post 11.

26. Primary Feed Magnet Equal (Selector Unit) -- This circuit is as follows: Post 8, primary feed magnet, Pri. C.L.C. #1 (H) R-14AU, one side of primary hopper R-2AL, basic set-up switch "P" "ON," one side of equal second primary R-26A one side of low primary R-22B, Multiple Secondary with Selection Switch "OFF," one side of low primary R-22A, equal R-23A, one side of low primary R-22A, error stop relay HS-4, CR-1, start relay R-17B to the other side of the line.

The secondary feed clutch is energized for the fourth cycle, due to the fact that the R-23B and R-25 relay points are closed.

27. Secondary Feed Magnet Equal Reading Selector Unit
High Second Primary Reading Sequence Unit -- This circuit is as follows: Post 8, secondary feed magnet, one side of secondary hopper R-4A, Sec. Mach. C.L.C., basic set-up switch "S" "ON," one side of low second primary R-27, high second primary R-25, equal second primary R-26B (normally closed), equal R-23B, one side of low primary R-22B, one side of equal R-23A, and out to post 11, as in previous circuits. It should be noticed that when the Multiple Secondary with Selection Switch is "OFF," that both feeds operate when an equal condition exists in the selector unit at the same time that a high second primary condition exists in the sequence unit.

CR-1 completes all feed magnet circuits from 201° to 221°. Before CR-1 makes, CR-2 at 185° sends an impulse through the selector and sequence units, to determine the readings set up, and pick up relays accordingly. These relays stay up until CR-2 breaks at 223° so that there is ample time for feed magnet circuits



to be completed by CR-1, as CR-2 timing overlaps CR-1 timing. The primary and secondary feed clutches unlatch and latch at 226° while the eject clutch unlatches and latches at 235°.

On the fourth cycle, cards in both feeds advance one station, as noted in Fig. No. 23. This figure also shows the readings that will be entered into the units on this cycle. It should be noticed that at 185° on the fourth cycle, a low primary condition in the selector unit, together with a high second primary condition in the sequence unit, exists. The low primary reading causes the primary feed to operate on the fifth cycle due to the fact that low primary R-22B is closed when CR-1 makes at 201°. The secondary feed clutch does not operate on the fifth cycle. See Fig. No. 26.

The machine stops at the end of the fifty cycle, due to the fact that the last card has left the primary feed, and the primary hopper contact makes, energizing the primary hopper relays R-1 and R-2. The primary hopper R-1AL transfers and opens the test circuit for the start relay. It is now necessary to depress the run-out key, closing the run-out key contact #1, in order to pick up the start relay R-17. It is necessary to hold the run-out key down until the cards have completely left one feed.

Inasmuch as a low secondary condition exists at this time, the secondary feed operates on the 6th cycle, due to the fact that the low secondary relay R-24 is energized on a low secondary reading in the selector unit. See Fig. No. 27.

28. Secondary Feed Magnet, Low Secondary Reading, Selector Unit -- This circuit is as follows: Post 8, secondary feed magnet, one side of the secondary hopper R-4A, Sec. C.L.C (H) R-9BL (normally open), one side of secondary hopper R-4A, one side of Sec. Machine C.L.C., basic set-up switch "S" "ON," one side of low second primary R-27, low secondary R-24, one side of equal R-23B, and out to post 11.

The operation of the feeds is at all times under the control of the sequence and selector units. Their operation is controlled in the following manner:

With Multiple Secondary with Selection Switch "OFF:"

Readings

<u>Selector Unit</u>	<u>Seq. Unit</u>	<u>Feed Operated</u>	<u>Cause</u>
Equal	Equal	Pri. and Eject	R-23A
Equal	High 2nd	Pri. and Eject and Sec.	R-23A, R-23B, R-25
Low Pri.	-	Pri. and Eject	R-22A
Low Sec.	-	Sec.	R-24

After studying the above chart, the correct operation of the feed should easily be determined for any condition which might exist.

An equal condition exists on selector unit, and a high second primary reading exists in the sequence unit at the end of the sixth cycle. This causes both feeds to operate on the seventh cycle. See Fig. No. 29. At the end of the seventh cycle, a low primary reading exists in the selector unit. This reading causes the primary feed to operate for the 8th cycle. See Fig. No. 29. During

the eighth cycle, hot 9's are read from the primary brushes No. 1, due to the fact that the Pri. C.L.C. #1 R-7B drops back to normal at 236°.

At the end of the eighth cycle, an equal reading exists in the selector unit, and a high second primary reading exists in the sequence unit. This condition causes both feeds to operate. See Fig. 30. As the last cards leave the machine hot 9's are read from the secondary brushes and also from the primary brushes No. 2.

The primary brushes No. 1 and primary brushes No. 2 hot 9 circuits are the same as traced previously.

29. Secondary brush hot 9 -- This circuit is as follows: Post 2, secondary magnets of selector unit, secondary plughub positions, plugwires to secondary brushes plughub positions, secondary brushes, contact roll, common brush one side of Sec. C.L.C. R-5A, secondary hopper R-4B secondary commutator No. 1, break circuit breakers, make circuit breakers, CR-3 to post 1.

In the event that the cards in both feeds do not end up with the same control number, the hot 9 would cause the feed in which cards remain to operate due to a low reading in that feed.

When merging and using both of the comparing units as wired in plugboard drawing No. 20, it should be noticed that both feeds operate at the same time whenever an equal condition exists in the selector unit, and a high second reading exists in the sequence unit. This operation saves one cycle in the machine each time the sequence unit senses a change in the control number of the cards that are feeding in the primary feed.

If desired, a merging operation can be performed by the use of the selector unit only, leaving the sequence unit for comparison of some other information. However, when using the selector unit only for merging operations, it is not possible to save a cycle each time the control number changes in the primary feed, the feeding in this case being from an equal or low primary on the primary side and low secondary on the secondary side. The speed of the machine in this case would be 240 ejected cards per minute, whereas if both comparing units are utilized when merging, the card output of the machine is 240 plus the number of control number changes per minute.

MERGING WITH SELECTION

Selection of those cards or groups of cards in the primary feed not represented in the secondary feed can be effected while merging by insertion of a plugwire from the plug hubs marked "Low Primary" to the plug hubs marked "Primary Selection." Any time that a low primary condition exists in the selector unit, the primary select magnet will be energized, causing the card or cards to be deposited in the "Selected Primaries" pocket.

30. Primary Select Magnet Circuit -- The circuit to the primary select magnet when a low primary condition exists in the selector unit is as follows: Post 12, primary select magnet, "Primary Select Magnet" plug hubs on plugboard, plugwire to "Low Primary" plug hubs on plugboard, one side of low primary R-22 coil, selector unit contacts, "Selector Control Input" plug hubs on plugboard, CR-2, one side of CR-1, start relay R-17B to post 11. This circuit is completed at 185° by CR-2 and would cause card #12 in Fig. No. 5 and card #15 in Fig. No. 8



to be selected, as these cards are not represented in the secondary feed.

Selection of cards in the secondary feed that are not represented in the primary feed can be effected while merging by insertion of a plugwire from the plug hubs "Low Secondary" to the plug hubs "Secondary Select--4." This will cause any card causing a low secondary reading in the secondary unit to be selected.

31. Secondary Select Magnet Circuit -- This circuit is as follows: Post 12, secondary select magnet 4, "Secondary Select Magnet --4" plug hubs, plugwire to "Low Secondary" plug hubs, one side of low secondary R-24 coil, selector unit contacts, "Selector Control Input" plug hubs, CR-2, one side of CR-1, start relay R-17B, to post 11. This circuit is also completed at 185° by CR-2 and will cause all cards in the secondary not represented by cards in the primary to be selected. It should be remembered that in selection operations while merging, the cards are not selected card for card, but that the selection is controlled by the group numbers, that is, if there is one card of an account number #16 in the primary and ten cards #16 in the secondary, all of these cards will enter the "merged cards and primaries not selected" pocket.

With the multiple secondary with selection switch in its "OFF" position, selection in the secondary can be effected only if single card groups exist in the secondary feed, that is, there can be only one card for each control number. This is due to the fact that as soon as a control change is sensed in the primary feed, the last primary card of a group and the first secondary card of the same group feed out together, at the same time the first card of the next group passes the primary brushes. This means that the control number for the preceding group has been replaced with the control number of the next group on the primary side of the selector unit and if multiple cards of the previous control number exist in the secondary feed, they will be selected from a low secondary reading. This, however, is not the correct operation, inasmuch as the secondary account number was represented in the primary feed. Selection in the secondary feed, with the Multiple S & S switch "OFF", is limited to those operations where single card groups are represented in the secondary feed.

In those operations where multiple card groups are present in the secondary feed and it is necessary to select those cards not represented in the primary feed, it is necessary to place the multiple secondary and selection switch in the "ON" position. This causes a slight variation in the feeding procedure, as can best be visualized by reference to the following chart:

With Multiple Secondary with Selection Switch "ON:"

<u>Readings</u>		<u>Feed</u>
<u>Selector Unit</u>	<u>Seq. Unit</u>	<u>Operated</u>
Equal	Equal	Pri. and Eject R-23A, R-23B, R-26A
Equal	High Sec.	Sec. and Eject R-23A, R-23B, R-25
Low Pri.	-	Pri. and Eject R-22A, R-22B Sec. R-24

It will be noticed that this chart is identical to that on Page No. except that when an equal condition exists in the selector unit and a high second card condition exists in the sequence unit, only the secondary feed and eject stations are operated. This means that the last primary card of a group and the first secondary card of the same group go to the pocket at the same time. See Fig. No. 31. However, the reading of the last primary card is retained in the

THINK

primary side of the selector unit for comparison with each secondary card of that group as it passes the secondary brushes. The secondary is operated in this case from an equal reading in the selector unit and a high second reading in the sequence unit. The secondary will continue to feed until a low primary reading is obtained. This low primary reading will cause the primary feed to operate, bringing the first card of the next group up to the eject station. If selecting cards in the primary, the low primary reading would effect operation of the primary select magnet. However, no card is selected, due to the fact that no card is standing in the eject station at the time the low primary reading is sensed. The card output of the machine is reduced when the Multiple S & S switch is placed in the "ON" position, as the primary feed must wait until a low primary condition exists; therefore, the output of the machine is 240 cards per minute.

In some cases it is desired to select equal cards in the primary feed and to substitute cards from the secondary feed for those selected. An example of this would be the replacement of old address cards with new in Insurance Accounting, etc. It is only necessary to insert a plugwire from the plug hubs "Equal" to the plug hubs "Primary Select." With this arrangement, any equal reading in the selector unit will cause selection. See plugboard set-up No.

At times a matching operation rather than a merging operation is used to determine those cards that are represented in each feed without merging the two groups together and to select those cards that are not represented in each feed. This can be accomplished by inserting a plugwire from the plug hubs "Plug to C" to the plug hubs "Secondary Select--3." The "Plug to C" hubs are hot at 201° of each cycle and will cause the energization of the secondary select magnet 3 so that all secondary cards will be inserted in the secondaries not selected pocket.

32. Secondary Select Magnet--3 Circuit-- This circuit is as follows: Post 12, Secondary Select Magnet--3, "Secondary Select Magnet--3" plug hubs, by plugwire to plug hubs "Plug to C," error stop relay, HS-4, CR-1, start relay R-17B, to post 11.

ADDITIONAL FUNCTIONS

Selectors are provided on the machine which allow operation of the selection or feed magnets through combinations of readings. These selectors are somewhat similar to an individual X selector on the printing equipment, except that no holding circuit is provided. Each selector consists of two pick-up hubs in common, a "C" hub, a "No X" hub, and an "X" hub. A typical set-up using one of these selectors is shown in plugboard set-up, Figure 32. In this particular job, which consists of a standard merging operation, all single unmatched primary cards will be selected. In other words, if there is only one unmatched primary card having a given control number, this card will be selected, whereas if there are two or more unmatched primary cards with the same control number, these cards will be merged with the secondary cards.

This selection of the single unmatched primary depends upon two successive high second card readings in the sequence unit, together with a low primary reading in the sequence unit. This combination causes energization of the primary select magnet.

Many other special and varied functional pluggings will occur in the customer's office, most of which will consist of combinations of the above-described

operations. For further study of some of these, please refer to Commercial Research Form No. 9137.

PLUGBOARD AND PLUGGING

Plugboard Layout -- An illustration of the Collator plugboard appears in Fig. No. 33. The plugboard is divided roughly into two sections. The lower section is devoted principally to "position" plugging, which connects the reading brushes to the operating magnets of the control units. The upper section is devoted to "functional" plugging, which determines the operation to be performed. This arrangement of the panel permits the relatively heavy position wiring to hang down without obscuring the functional wiring, and makes the functional wiring conveniently accessible for inspection or alteration.

Plugging the Brushes -- In the lower section of the board three groups of eighty hubs each are provided for the three rows of card-reading brushes. The location of these brushes in the machine is indicated in the schematic diagram of the Collator shown in Fig. No. 34.

As shown also in Fig. No. , the card-reading brushes are plugged to the magnet hubs of the Selector Control Unit and Sequence Control Unit. For most operations the Selector Unit is plugged between the primary brushes and secondary brushes, and the Sequence Unit is plugged between the primary brushes and primary sequence brushes. Since this involves the plugging of two magnet hubs from each primary brush, the primary selector magnets are provided with double-hubs in order to avoid the use of split-wires. The upper row of these double-hubs should normally be connected to the first primary sequence magnet hubs by means of "bottle-plugs," as indicated by the brackets engraved on the panel, and as shown in Fig. No. 33.

Because of the flexibility provided by this plugging arrangement, it is not necessary that the card fields used for control be the same in both primary and secondary cards. Typical position plugging illustrating this point is shown in the diagram in Fig. No. 34. Note, however, that ordinarily the plugging of the primary brushes and primary sequence brushes must be identical because one file of cards passes these two rows of brushes successively, as in an accounting machine.

Plugging the Control Unit Magnets -- In plugging the brushes to the magnet hubs, any of the sixteen control positions may be used, and in this respect the Selector and Sequence Units are like the automatic control unit in the alphabetic accounting machine. However, because these units detect which of two control numbers is lower, the card columns being compared must be plugged to the magnets from right to left in the same sequence used in sorting. Thus the 10's column must be plugged to the left of the unit column, the 100's column to the left of the 10's column, etc., so that each position plugged is "major" or superior to the next one at its right.

The reason for this plugging sequence is that the control units compare two numbers by testing the sixteen control positions successively from left to right. The first position found to be unequal determines which of the two numbers is lower. Thus, of the two numbers 001999 and 002000, 1999 is found to be lower because the "1" is lower than the "2."

The same principle applies if two card fields, representing for example account number and date, are used for control. The major field must be plugged to the left of the minor field, as in Fig. No. 35.

It should be noted that these control units are unlike those in our accounting machines in another respect. Each time a card is read into one "side" of a unit (e.g., the secondary magnets) it is "remembered," and subsequently used for comparison with cards read into the other side (e.g. the primary magnets), until such time as a new card is read into the first side.

For example, when a card punched 15 is read by the secondary brushes, and one punched 12 is read by the primary brushes, the lower primary card is ejected into the pockets. The primary number 12 is then "forgotten," and a new primary card punched 13 is fed and compared with the 15 "remembered" from the secondary card 15, which is still waiting to enter the pockets. As the new primary card is also lower, it is ejected, the primary side of the selector unit is restored (reset), another primary card is fed, and another comparison is made. This continues until the secondary goes low, due to comparison with a primary card punched 16. The secondary card 15 is then fed into the pockets, the secondary side of the selector unit is restored, and another secondary card is fed and read.

Plugging the restoring magnets -- Restoration of the control units, i.e., cancellation of control numbers previously read into the control units, is normally effected each time new cards are fed past the reading brushes. This is not only functionally necessary but mechanically necessary also. Unless a control unit is restored the reading in it is unaffected by passage of cards under the brushes connected to it.

Advantage can be taken of this fact in some cases, thereby making the use of class selectors unnecessary. For this purpose the four restoring magnets, one for each side of each control unit, are made pluggable. Their hubs are located in the lower right side of the plugboard. The S, P, PS-1, and PS-2 hubs represent the restoring magnets respectively of the secondary side and the primary side of the Selector Unit, and of the 1st and 2nd sides of the Pri. Sequence Unit. Normal connection by means of bottle-plugs to the hubs immediately below these hubs causes restoration of the control units each time a card is fed past the corresponding brushes. Any of the bottle-plugs can be removed if desired, and the restoring magnet plugged from some other controlling source.

Plugging the Control Inputs -- Also as an aid to flexibility, the main control input circuits are made pluggable. Their hubs are on the lower right side of the plugboard just over the restoring magnet hubs. The SEL hub is the input of the Selector Unit, and the PS hub is the input of the Primary Sequence Unit. These control input hubs are normally connected to the hubs immediately below them, which are "hot" every cycle, by means of bottle-plugs. By removing one of these bottle-plugs, the input of the corresponding control unit can be plugged from a selected control source, e.g. the Equal output hub of the other control unit, in order to meet unusual requirements.

Plugging for X-Card Control -- The hub designations PXP and SXP are abbreviations for primary X pick-up and secondary X pick-up. The PXP hubs can be plugged from any primary brush or primary sequence brush to operate the primary X relay represented by three hubs designated PRI. X in the upper section of the plugboard. The SXP can be plugged from any secondary brush to operate the corresponding secondary X relay, designated SEC X. These relays, together with the Plug to C hubs,



are used in much the same way as X distributors on an accounting machine, in order to control certain functions by means of X holes in the cards.

Switches -- The upper section of the plugboard, which is devoted to "functional" plugging, can be divided roughly into four parts - switches, control sources, selectors and controllable functions.

Most Collator operations involve the merging or matching of two files of cards. This requires proper co-ordination of the primary and secondary card-feed control circuits. The functional plugging which would be necessary for this purpose is shown in Fig. No. 36.

Because of its common use the wiring drawn in solid lines in Fig. No. is known as the "basic set-up." This set-up involves rather complicated functional plugging, and in order to make this plugging unnecessary the Basic Set-up switch has been provided. Plugging the Basic Set-up switch ON establishes circuits inside the machine exactly the same as those made by the plugging shown in solid lines in Fig. No. 36. As a result, for most Collator operations, functional plugging is required only for selection of primary and secondary cards, and for primary sequence checking, as explained below. If feed control other than that provided by the basic set-up is arranged through functional plugging, the Basic Set-up switch must be plugged OFF.

The Mult. S & S switch, (on some panels wrongly labeled Mult. S & R), generally will also have to be plugged ON when merging or matching cards. Mult. S & S is an abbreviation of Multiple Secondary and Selection, which in turn briefly suggests the purpose of this switch. The rules for its use are as follows:

1. The Mult. S & S switch must be plugged ON if the secondary cards include any multi-card groups (more than one card containing the same control number), and either matched (equal) or unmatched (low) secondary cards are being selected.
2. The Mult. S & S switch should be plugged OFF if either there are no multi-card secondary groups, or matched or unmatched secondary cards are not being selected.

With the Mult. S & S switch OFF, one machine cycle is saved for each matched secondary group, and the effective machine speed is therefore increased. This saving cannot be realized, if there are multiple secondary groups and matched or unmatched secondary cards are being selected.

When the Pri. Change switch is plugged ON, the Sequence Unit is included in the basic set-up circuit. In this case the Sequence Unit is used like the control unit in an accounting machine, to determine when there is a change from one control number to another in the primary card. The "change" will ordinarily be a step-up from one control number to a higher one, but may be a step-down, as in case of an error in primary sequence, or at the end of a run.

The Pri. Change switch must be ON whenever the Mult. S & S switch is ON, because in that case the Sequence Unit must be used in the normal manner. In other cases in which the Basic Set-up switch is ON, but the Mult. S & S switch is OFF, the Primary Change switch should be plugged ON, if possible. However, it may be desirable to use the Sequence Unit for some other purpose, in which case the Pri. Change switch must be turned OFF, in order that the Basic Set-up circuit may

function properly without help from the Sequence Unit.

The Interlock switch controls selection of cards during run-out. The Interlock switch should be ON when using both primary and secondary feeds in conjunction with each other, as is ordinarily the case. When using either feed alone, as when checking the sequence of a single file of cards, this switch should be turned OFF.

Functional Plugging -- At the top of the plugboard are the hubs representing sources of control, selectors, and functions controllable. These are ordinarily plugged from left to right, from sources of control, through selectors, if necessary, to functions to be controlled.

Plug to "C"-- There are two classes of source hubs, constant and controlled. The constant source hubs are in a vertical, common row of five, designated Plug to C, in the area labeled Selectors. These hubs are designated Plug to C because they are used in much the same manner as the Plug to C hubs in an accounting machine. Any function plugged directly from a Plug to C hub is actuated during every machine cycle.

Controlled Sources -- The controlled source hubs are in the upper left corner of the panel. There are six of these sources, each represented by a horizontal row of four common hubs in order to avoid the use of split-wires. The first three rows, designated Low Secondary, Equal and Low Primary, are under control of the Selector Unit. The lower three rows, designated High 2nd Primary, Equal 2nd Primary and Low 2nd Primary, are under control of the Sequence Unit.

These controlled source hubs are actually the output hubs of the control units. Unlike the control unit in an accounting machine, which has one output (or shunt) hub for each control position, a Collator control unit has the equivalent of only one output hub for all sixteen control positions. It is impossible to shunt out any control positions plugged from the brushes. Each unit must be used as a complete, sixteen-position control unit. The three groups of output hubs provided for each unit are actually three kinds of outputs, or sources, each controlled by all sixteen positions in the control unit.

The conditions under which these controlled sources become active are suggested by their designations. With the Selector plugged normally between the Primary and Secondary Brushes, the Low Secondary hubs are active, or "hot," when the secondary reading is the lower. The Equal hubs are hot when the primary and secondary readings are identical, and the Low Primary hubs are "hot" when the primary reading is the lower. Similarly, with the Sequence Unit plugged normally between the primary brushes and primary sequence brushes, the High 2nd Primary hubs are hot when the 2nd primary reading is the higher. The Equal 2nd Primary hubs are hot when the 2nd Primary reading is equal, or in other words when there is no "primary change" in control number. The Low 2nd Primary hubs are hot when the 2nd primary reading is the lower, as when a step-down in primary sequence occurs.

Controllable Functions -- In most cases these controlled sources will be plugged directly to the controllable functions whose hubs are located in the upper right corner of the panel. Each function is represented by a horizontal row of four common hubs in order to avoid the use of split-wires.



Plugging for Selection -- The Secondary Selection and Primary Selection Control hubs are connected to magnetically operated "gates" which determine which pockets the cards will enter. The function of each of these "gates" is made clearer by reference to the schematic diagram in Fig. No. 43. The Secondary Selection Control diverts into the fourth pocket all cards which would otherwise enter either the second or third pocket. The Primary Selection Control diverts into the first pocket all cards which would otherwise enter the second pocket.

Unmatched cards are selected as low cards. For example, when matching master and detail cards, unmatched master cards are selected by plugging from Low Primary to Primary Selection. Similarly, in the same example, unmatched detail cards are selected by plugging from Low Secondary to Secondary Selection #4.

Matched cards are selected as equal cards. For example, when pulling cards from file by means of another set of cards, the "pulling" cards are run in the secondary feed, and the cards to be pulled are selected by plugging from Equal to Primary Selection.

Plugging for Matching -- If desired, the primary and secondary cards not selected can be kept separate instead of being merged. This is accomplished by plugging from the Plug to C hubs to the plug hubs Secondary Selection --3. Primary cards not selected will then continue to enter the second pocket, but secondary cards not selected will enter the third pocket instead of the second. This arrangement is intended for applications in which two groups must be matched, but should not be merged together.

Plugging for Card Feeding and Ejection -- In special operations for which the basic feed-control set-up is not suitable, the Basic Set-up switch is turned OFF, and proper card feeding is obtained by functional plugging. Feeding of secondary cards is controlled through the Sec. Feed hubs, one card being fed each time a source impulse reaches these hubs.

The primary card feeding mechanism is divided into two parts for proper operation when the Mult. S & S switch is ON; otherwise these two parts or stages of primary feeding operate in unison. The Pri. Feed hubs control primary feeding until the cards have passed the primary brushes. The Pri. Eject hubs control ejection of the primary cards from that point into the card pockets. If it is desired to feed and eject primary cards continuously, it is necessary only to plug to C to Pri. Feed, thence to Pri. Eject.

Plugging for Error Detection -- Primary card sequence may be checked during any operation. For this purpose, plug from Low 2nd Pri. to Error Stop. When a step-down in primary sequence occurs, the error light is turned on and the machine is stopped. This feature can also be used for other checking purposes, through proper use of the flexibility provided by functional plugging.

Plugging for X Card Control -- When it is necessary to control one of these functions from X-holes in the cards, the proper card brushes are plugged to the PXPU or SXPU hubs to operate the Pri. X and Sec. X selectors. It is then necessary only to plug from Plug to C hub to the C hub of the X-selector used, and from either the corresponding NX or X hub, as required, to the function to be controlled.

When a function is to be controlled from a combination of an X-hole and a control unit source, that source (instead of Plug to C) is plugged through the X selector to the function involved.

Plugging the Independent Selectors -- When a function is to be controlled from a combination of two control unit sources, two of the five independent selectors must be used, as shown in Fig. No. 37. The selector pick-up hubs are plugged from the source hubs the same as the X pick-up hubs of X distributors. It is then necessary only to plug from Plug to C first through one of the selectors and then through the other to the function involved. Only Plug to C source impulses should be plugged through these independent selectors.

Plugging the Primary Cycle Delay -- The Primary Cycle Delay hubs are provided in order that a control source active in one cycle may be "remembered" and used in the next primary cycle. The PU hubs, like those of the selectors, can be plugged from any control source. If the Pri. Cycle Delay is picked up during one cycle, the two unlabeled pairs of hubs will be connected together during the following primary cycle. As in the examples in Fig. No. 17B, by plugging from High 2nd Pri. to Pri. Select, the last card of each primary group will be selected. By plugging from High 2nd Pri. to a Pri. Cycle Delay PU hub, and plugging from Plug to C through the Pri. Cycle Delay to Pri. Select, the next following cards, i.e., the first card of each primary group, will be selected. By plugging from High 2nd Pri. to the Cycle Delay PU, and then on through the Cycle Delay to Pri. Select, only single primary cards will be selected.

FIG. 1

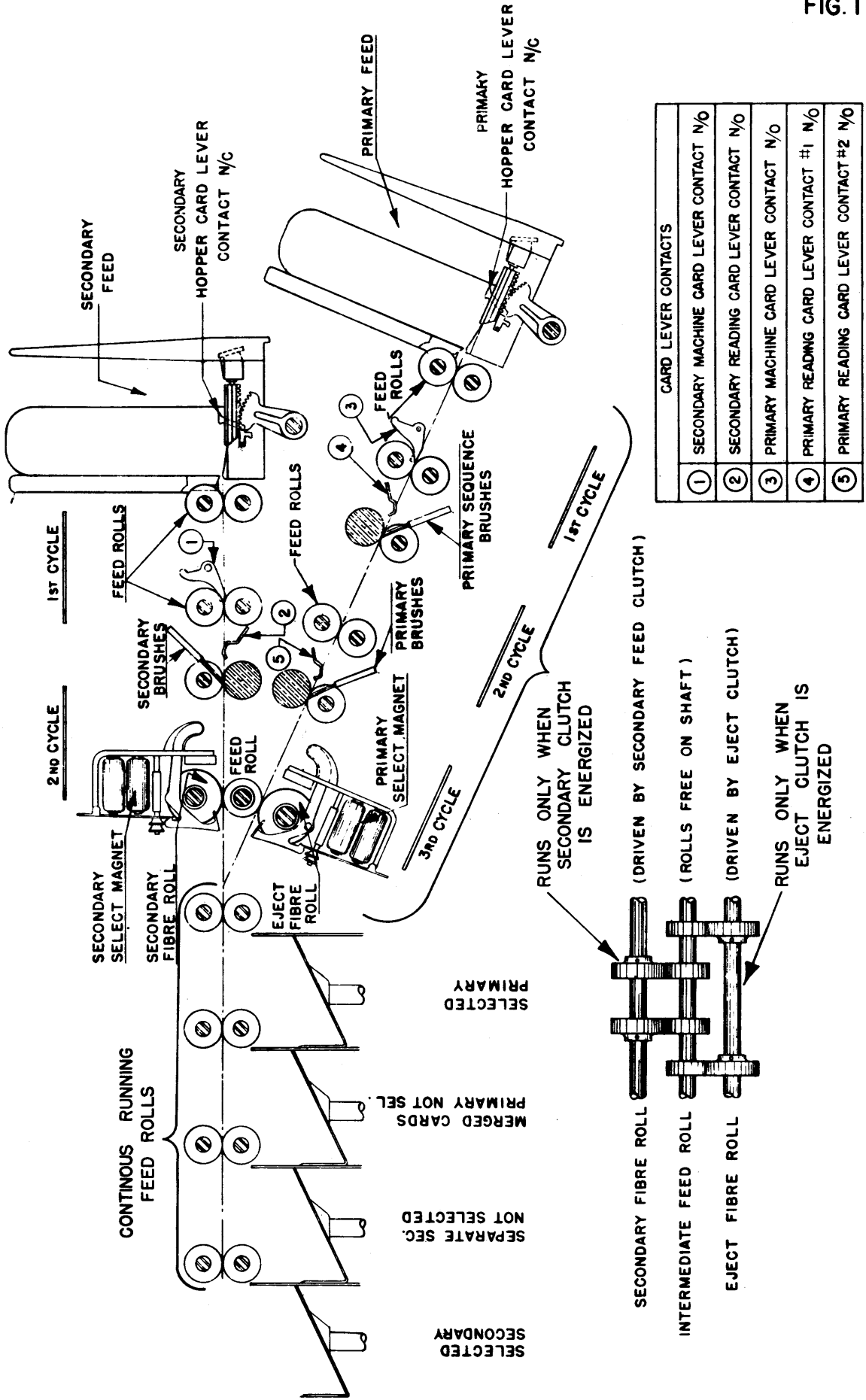

SELECTED SECONDARY

SEPARATE SEC. NOT SELECTED

MERGED CARDS PRIMARY NOT SEL.

SELECTED PRIMARY

SECONDARY FIBRE ROLL (DRIVEN BY SECONDARY FEED CLUTCH)

INTERMEDIATE FEED ROLL (ROLLS FREE ON SHAFT)

EJECT FIBRE ROLL (DRIVEN BY EJECT CLUTCH)

RUNS ONLY WHEN EJECT CLUTCH IS ENERGIZED

RUNS ONLY WHEN SECONDARY CLUTCH IS ENERGIZED

CONTINUOUS RUNNING FEED ROLLS

SECONDARY SELECT MAGNET

SECONDARY FIBRE ROLL

EJECT FIBRE ROLL

PRIMARY SELECT MAGNET

PRIMARY BRUSHES

PRIMARY SEQUENCE BRUSHES

2ND CYCLE

1ST CYCLE

2ND CYCLE

1ST CYCLE

SECONDARY FEED

SECONDARY HOPPER CARD LEVER CONTACT N/C

PRIMARY FEED

PRIMARY HOPPER CARD LEVER CONTACT N/C

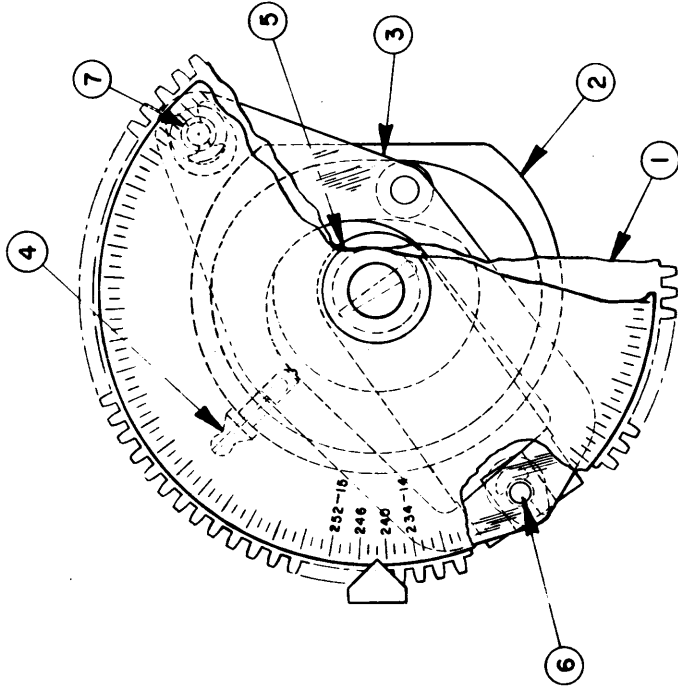

RELATIVE POSITIONS OF PARTS AT
APPROXIMATELY 242° ON THE INDEX
AND 160 C.P.M.

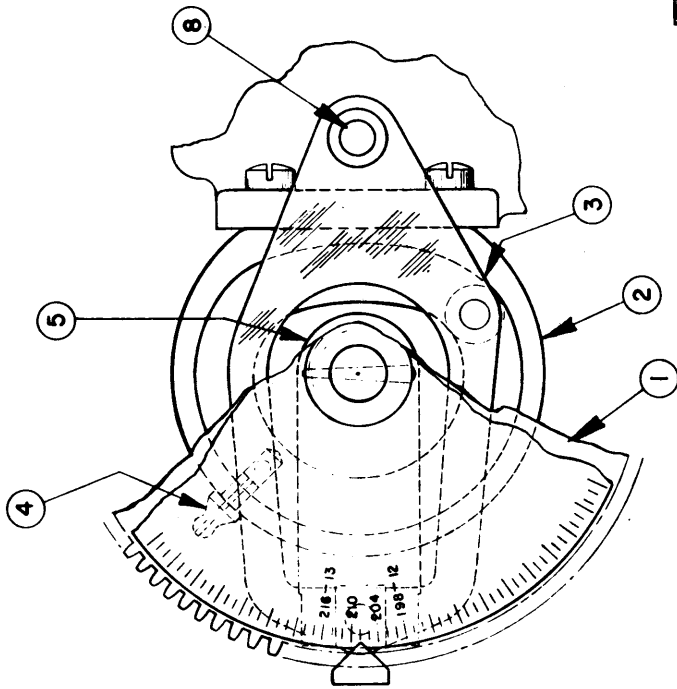

RELATIVE POSITIONS OF PARTS AT
APPROXIMATELY 208° ON THE INDEX
AND 205 C.P.M.

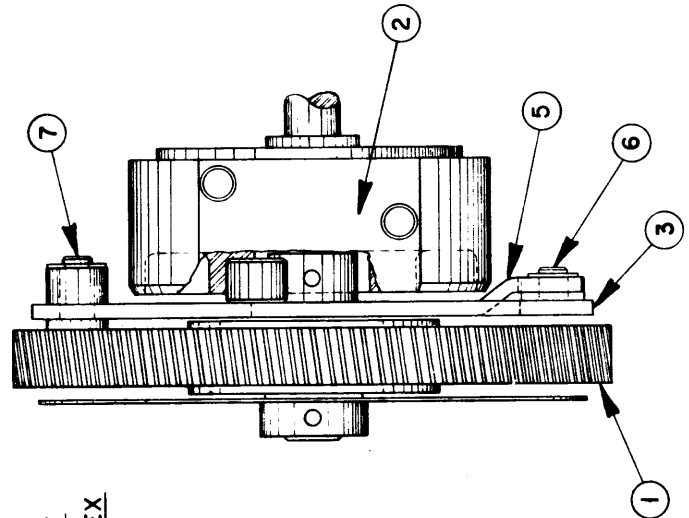

NO.	PART NAME
1	MAIN DRIVE SHAFT GEAR
2	VARIABLE SPEED CAM
3	VARIABLE SPEED CAM FOLLOWER
4	CAM RACE GREASE FITTING
5	VARIABLE SPEED SHAFT LEVER
6	VARIABLE SPEED SHAFT LEVER DRIVE STUD
7	CAM FOLLOWER DRIVE STUD
8	HOLE IN CAM FOLLOWER FOR DRIVE STUD

FIG. 3

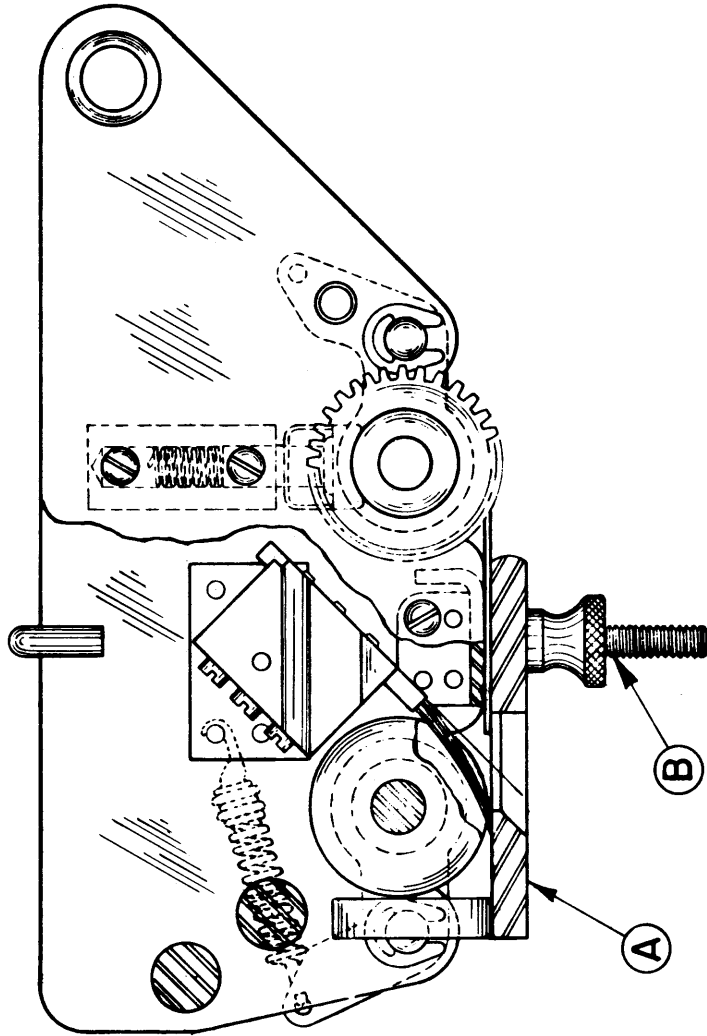

NO.	PART NAME
1	SECONDARY SELECT MAGNET
2	SELECTED SECONDARY MAGNET ARMATURE
3	MATCH POCKET MAGNET ARMATURE
4	SELECT SHOES
5	SELECT MAGNET ARMATURE ADJUSTING SCREW
6	SECONDARY FIBRE ROLL
7	INTERMEDIATE FEED ROLL
8	PRIMARY FIBRE ROLL
9	PRIMARY SELECT MAGNET
10	CHUTE BLADE ASSEMBLY NO.1 POCKET
11	CHUTE BLADE ASSEMBLY NO.2 POCKET
12	CHUTE BLADE ASSEMBLY NO.3 POCKET
13	EJECT MAGNET ARMATURE KNOCKOFF
14	EJECT ARM AND DETENT
15	EJECT CLUTCH GEAR
16	EJECT CLUTCH GEAR KNOCKOFF BLOCK
17	EJECT CLUTCH ARMATURE PIVOT PLATE
18	SELECT MAGNET ARMATURE KNOCKOFF CAM
19	SELECT MAGNET LEVER RESTORING CAM

FIG. 4-B

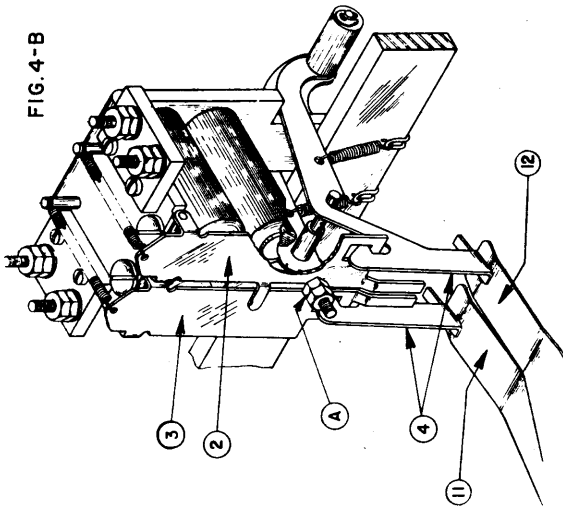

SECONDARY SELECT MAGNET

FIG. 4-A

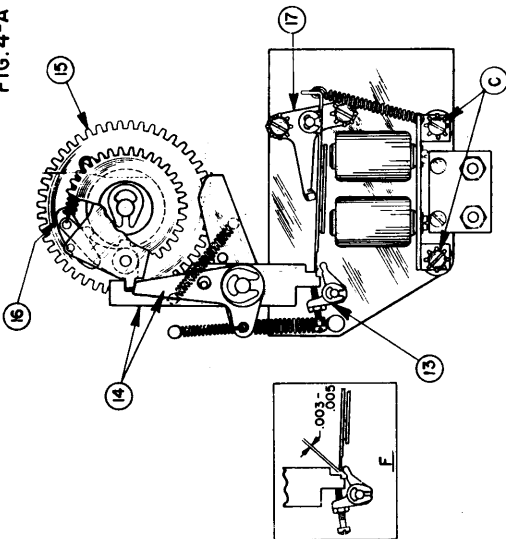

EJECT CLUTCH ASSEMBLY

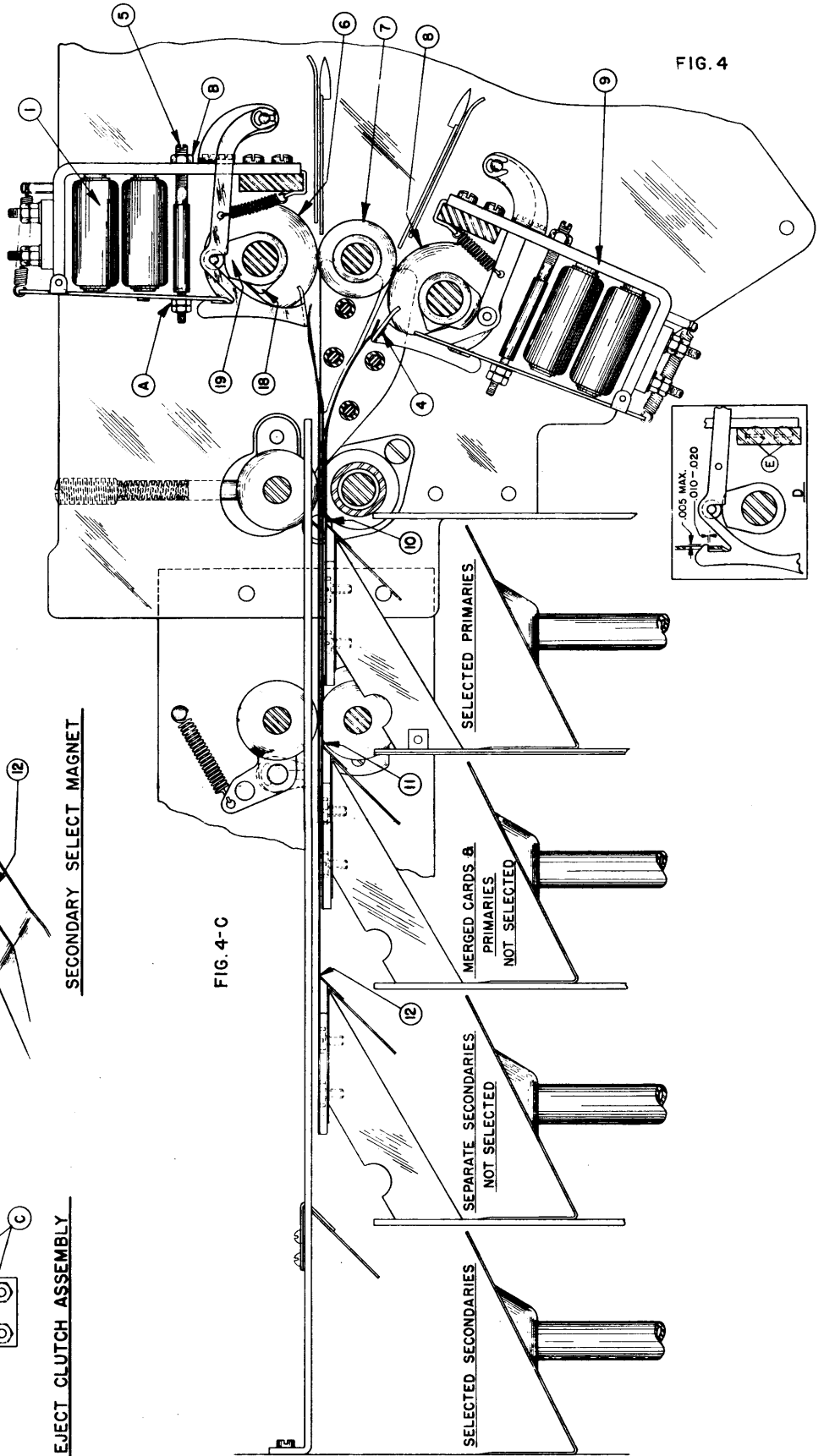
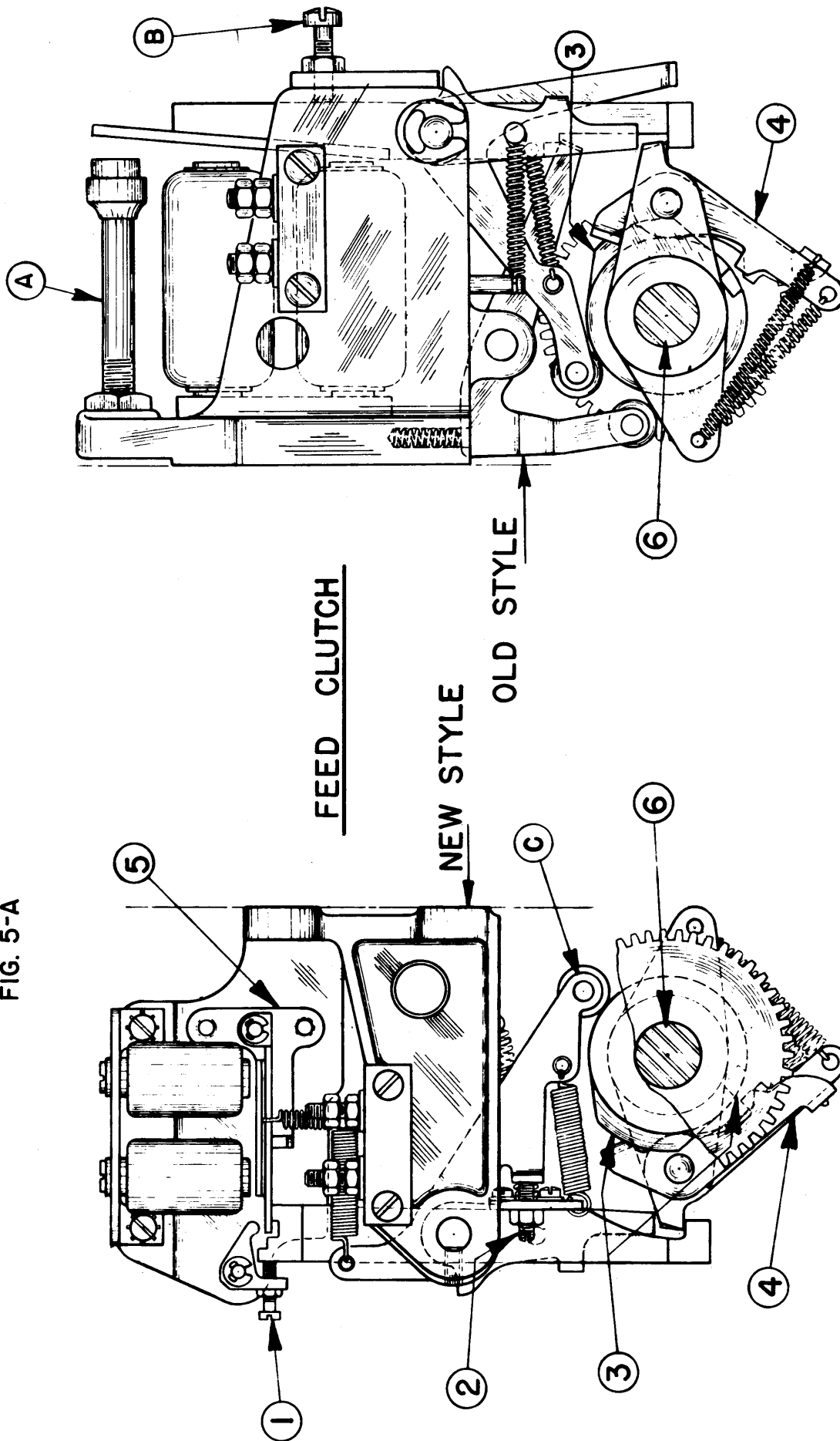

FIG. 4-C

FIG. 4

FIG. 5-A



NO.	PART NAME	NO.	PART NAME
1	CLUTCH MAGNET ARMATURE KNOCKOFF ADJ. SCREW	5	CLUTCH MAGNET ARMATURE PIVOT PLATE
2	FEED CLUTCH ARMATURE LATCH ADJ. SCREW	6	MAIN DRIVE SHAFT
3	FEED CLUTCH ARM. LATCH CAM & RATCHET		
4	CLUTCH LEVER AND DOG ASSEMBLY		

FIG. 6

NO.	PART NAME
1	CARD FEED CAM SECONDARY
2	CARD FEED CAM FOLLOWER
3	CARD PICKER SHAFT
4	PICKER KNIFE SECTOR
5	MAIN DRIVE SHAFT
6	FEED ROLL SPIRAL GEAR

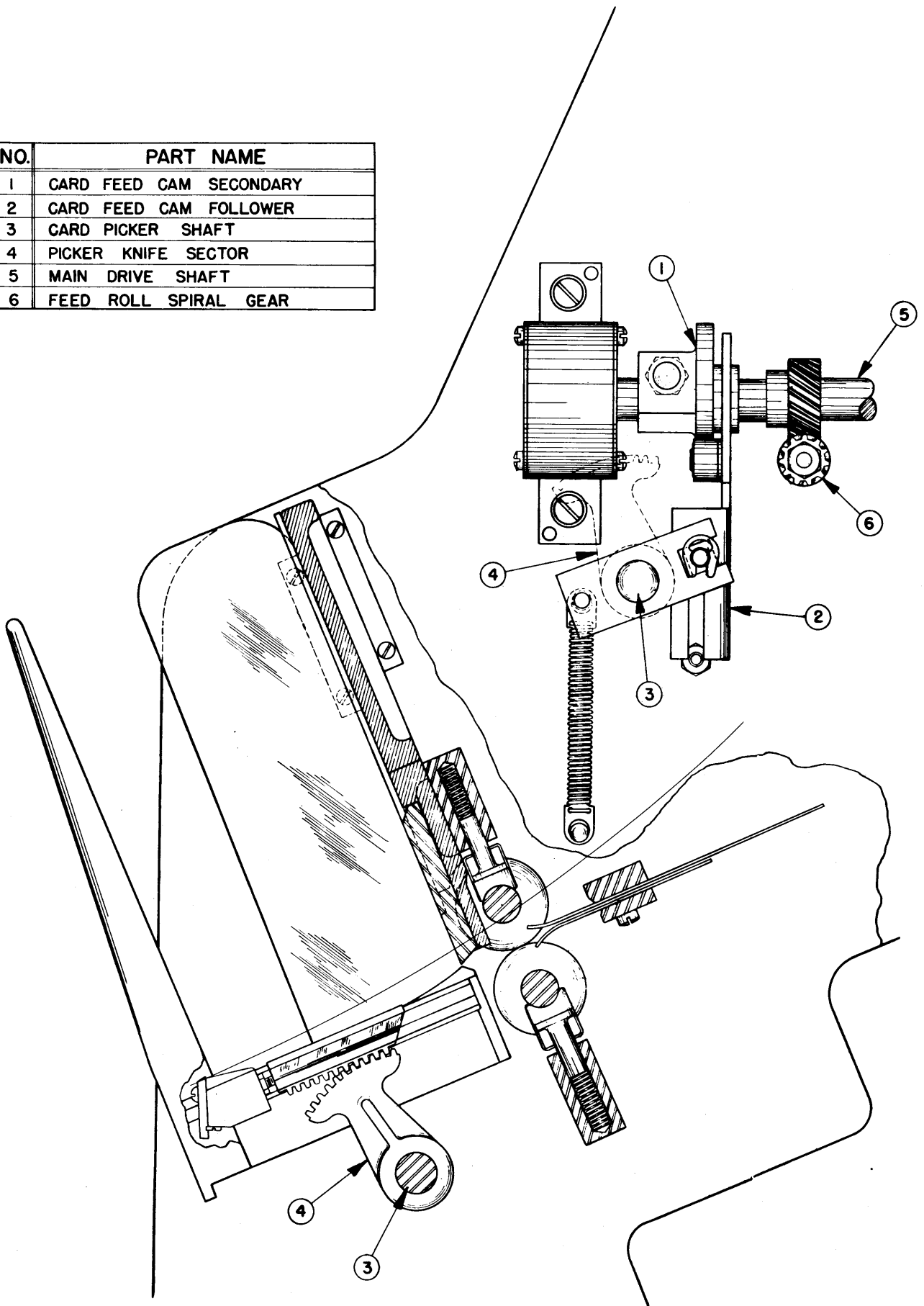

CARD FEED MECHANISM

FIG. 7

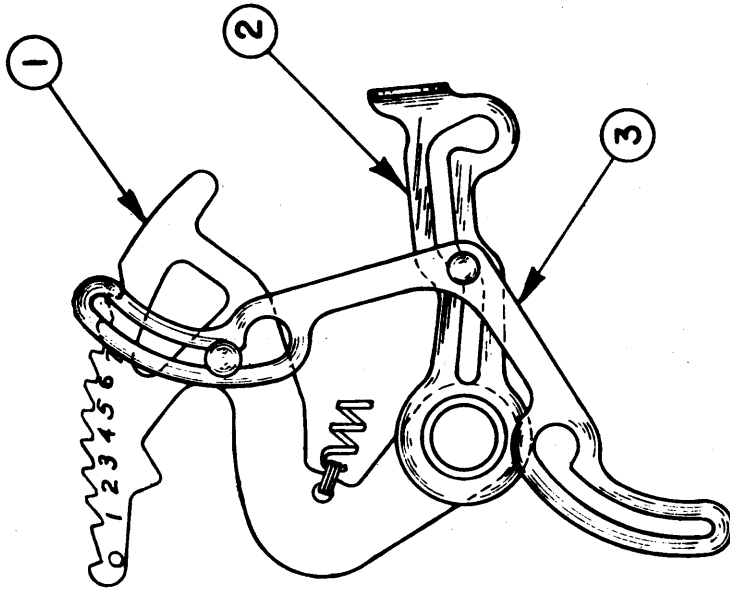
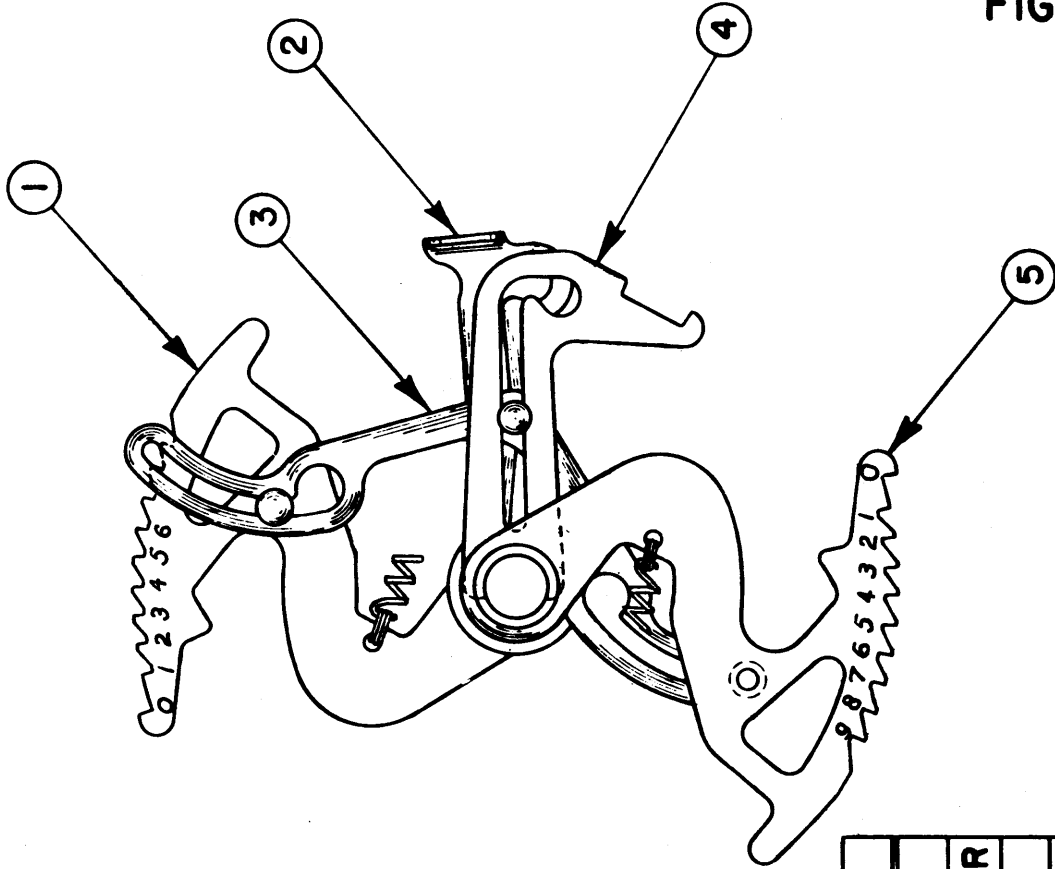

NO.	PART NAME
1	SET-UP RATCHET
2	SELECTION CONTACT CONTROL LEVER
3	DIFFERENTIAL LINK
4	DIFFERENTIAL LINK GUIDE PLATE
5	SET-UP RATCHET

FIG. 8

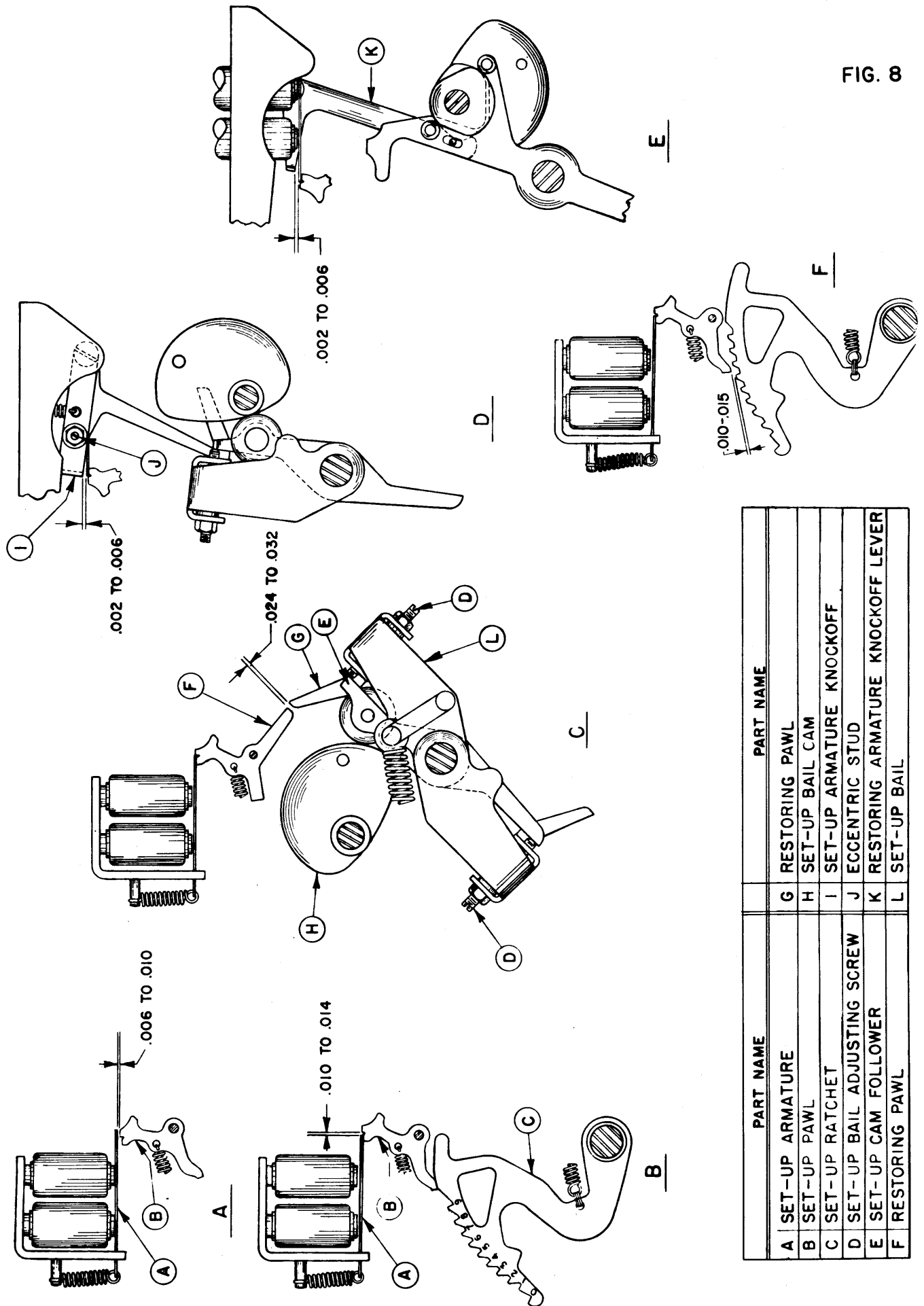

PART NAME	PART NAME
A SET-UP ARMATURE	G RESTORING PAWL
B SET-UP PAWL	H SET-UP BAIL CAM
C SET-UP RATCHET	I SET-UP ARMATURE KNOCKOFF
D SET-UP BAIL ADJUSTING SCREW	J ECCENTRIC STUD
E SET-UP CAM FOLLOWER	K RESTORING ARMATURE KNOCKOFF LEVER
F RESTORING PAWL	L SET-UP BAIL

HIGH SPEED CONTACT ROLL

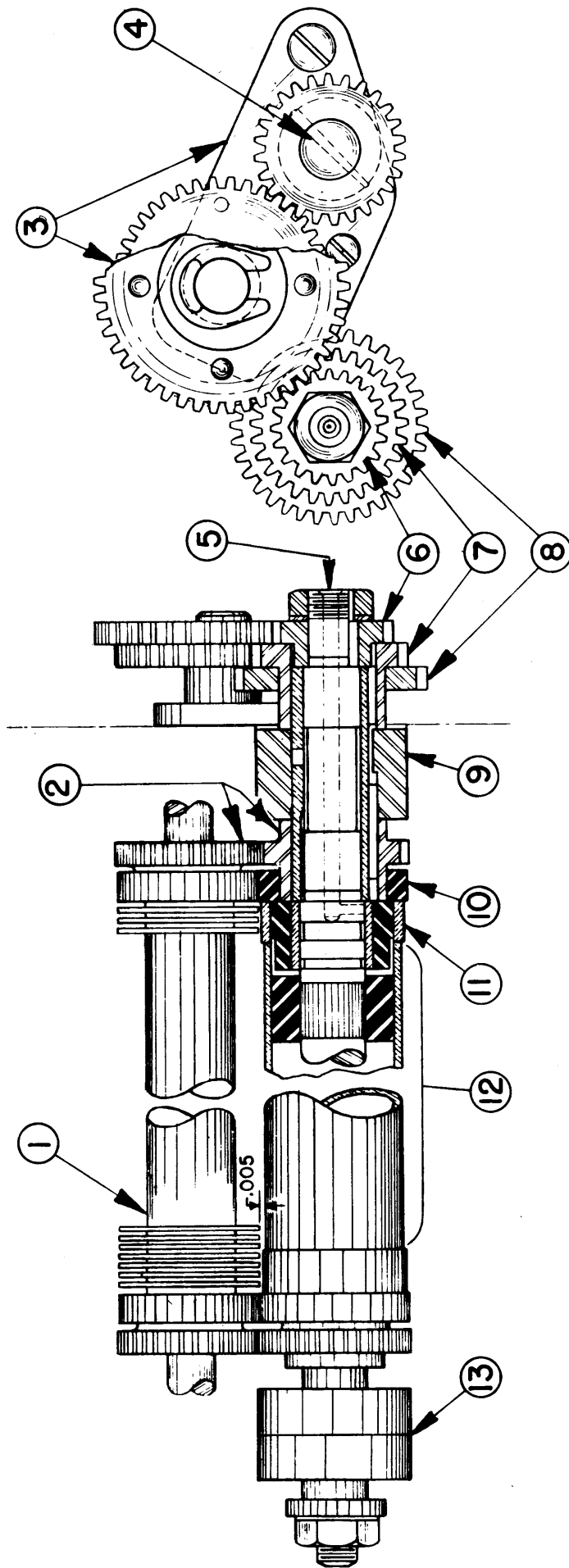

NO.	PART NAME	NO.	PART NAME
1	BRUSH GUIDE ROLL ASSEMBLY	8	CONTACT ROLL SHAFT IDLER GEAR
2	BRUSH GUIDE ROLL GEAR AND DRIVE	9	CONTACT ROLL FRONT END BEARING
3	CONTACT ROLL IDLER GEARS & BRACKET	10	CONTACT ROLL CARD SPEED SECTION
4	FEED ROLL SHAFT	11	CONTACT ROLL IDLER SECTION
5	LUBRICATING RESERVOIR	12	CONTACT ROLL HIGH SPEED SECTION
6	DRIVE GEAR FOR HIGH SPEED SECTION	13	CONTACT ROLL REAR BEARING
7	DRIVE GEAR FOR CARD SPEED SECTION		

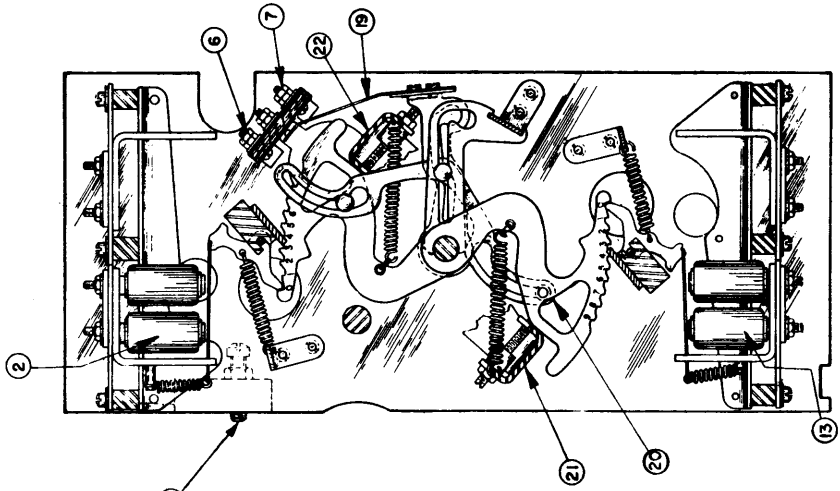

SET UP MECHANISM

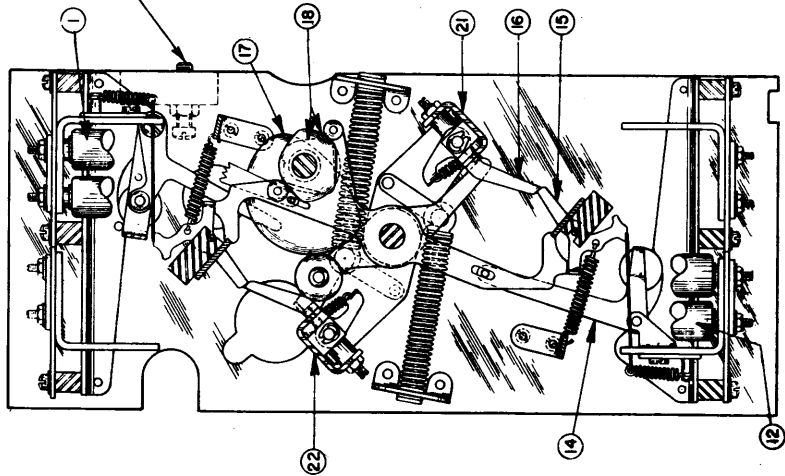
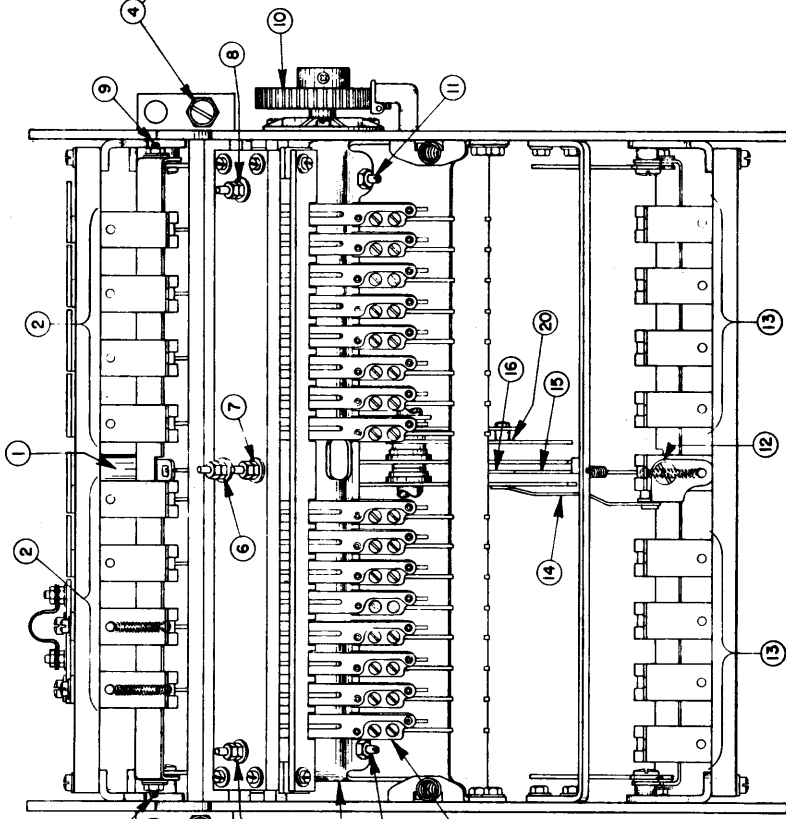

RESTORING MECHANISM

SEQUENCE UNIT	NO	SELECTOR UNIT
UNIT TO LEFT VIEWED FROM		UNIT TO RT VIEWED FROM
OF MACHINE		OF MACHINE
1 SECOND PRIMARY RESTORING MAGNET	1	SECONDARY RESTORING MAGNET
2 SECOND PRIMARY SEQUENCE MAGNETS	2	SECONDARY SELECTOR MAGNETS
3 UNIT ADJUSTING SCREW (LEFT)	3	SAME
4 UNIT ADJUSTING SCREW (RIGHT)	4	SAME
5 CONTACT STRIP COMMON TERMINAL (INPUT)	5	SAME
6 CONTACT STRIP HIGH SECOND TERMINAL	6	CONTACT STRIP LOW PRIMARY TERMINAL
7 CONTACT STRIP LOW SECOND TERMINAL	7	CONTACT STRIP LOW SECONDARY TERMINAL
8 CONTACT STRIP EQUAL TERMINAL	8	SAME
9 SET-UP ARMATURE KNOCKOFF BAIL ADJUSTING SCREWS	9	SAME
10 UNIT DRIVE GEAR	10	SAME
11 SET-UP BAIL ADJUSTING SCREW	11	SAME
12 FIRST PRIMARY RESTORING MAGNET	12	PRIMARY RESTORING MAGNET
13 FIRST PRIMARY SEQUENCE MAGNETS	13	PRIMARY SELECTOR MAGNETS
14 RESTORING ARM LEVER KNOCKOFF	14	SAME
15 RESTORING PAWL	15	SAME
16 RESTORING PAWL LATCH	16	SAME
17 RESTORING PAWL CAM	17	SAME
18 RESTORING PAWL RESET CAMS	18	SAME
19 SELECTION CONTACT SPRING	19	SAME
20 SET-UP RATCHET ASSEMBLY	20	SAME
21 FIRST PRIMARY SET-UP BAIL	21	PRIMARY SET-UP BAIL
22 SECONDARY PRIMARY SET-UP BAIL	22	SECONDARY SET-UP BAIL
23 SELECTOR CONTACT ASSEMBLY ADJUSTING SCREW	23	SAME

FIG. 12

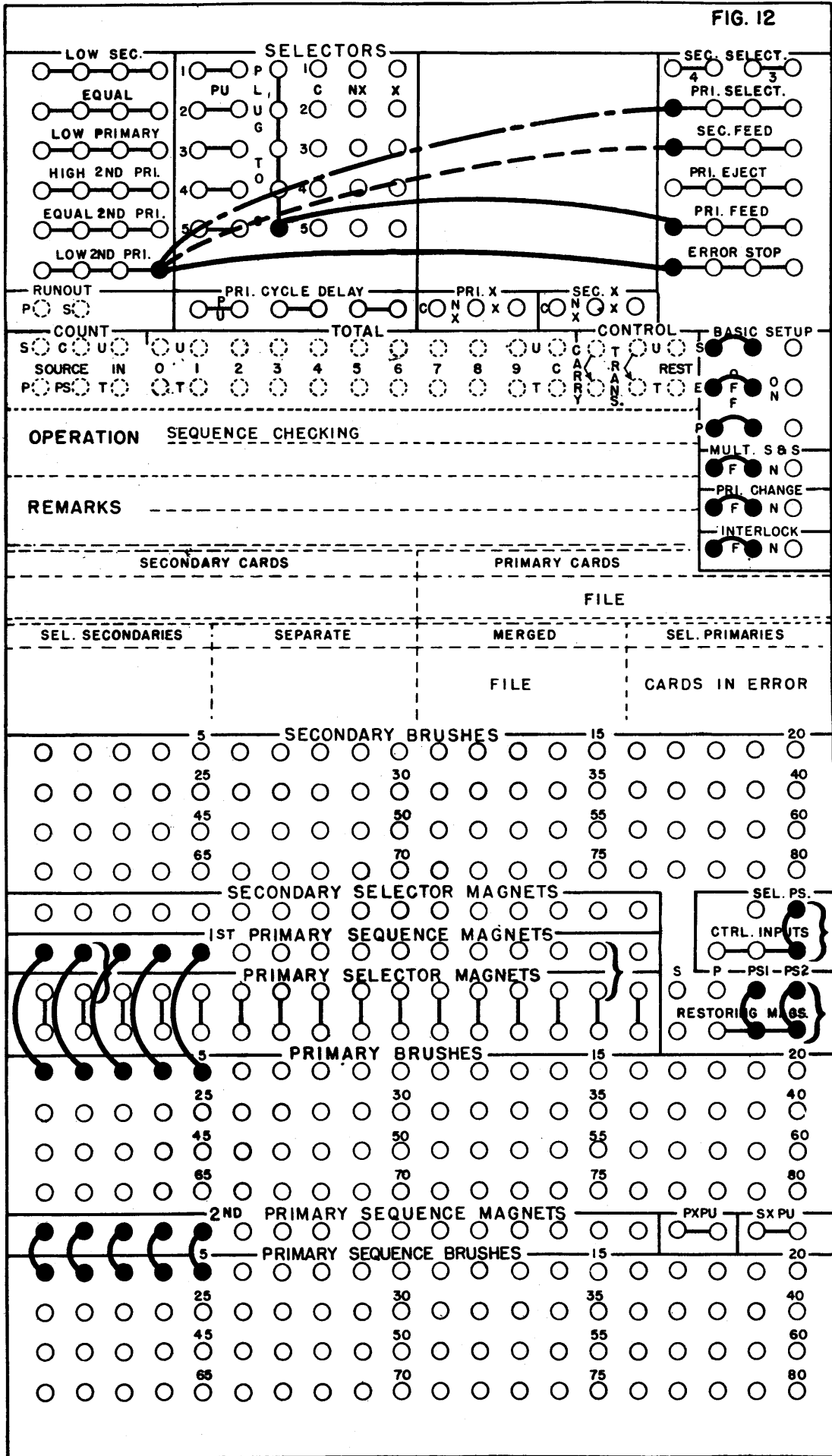

POSITION OF CARDS AT END OF FIRST CYCLE

SECONDARY
FEED HOPPER

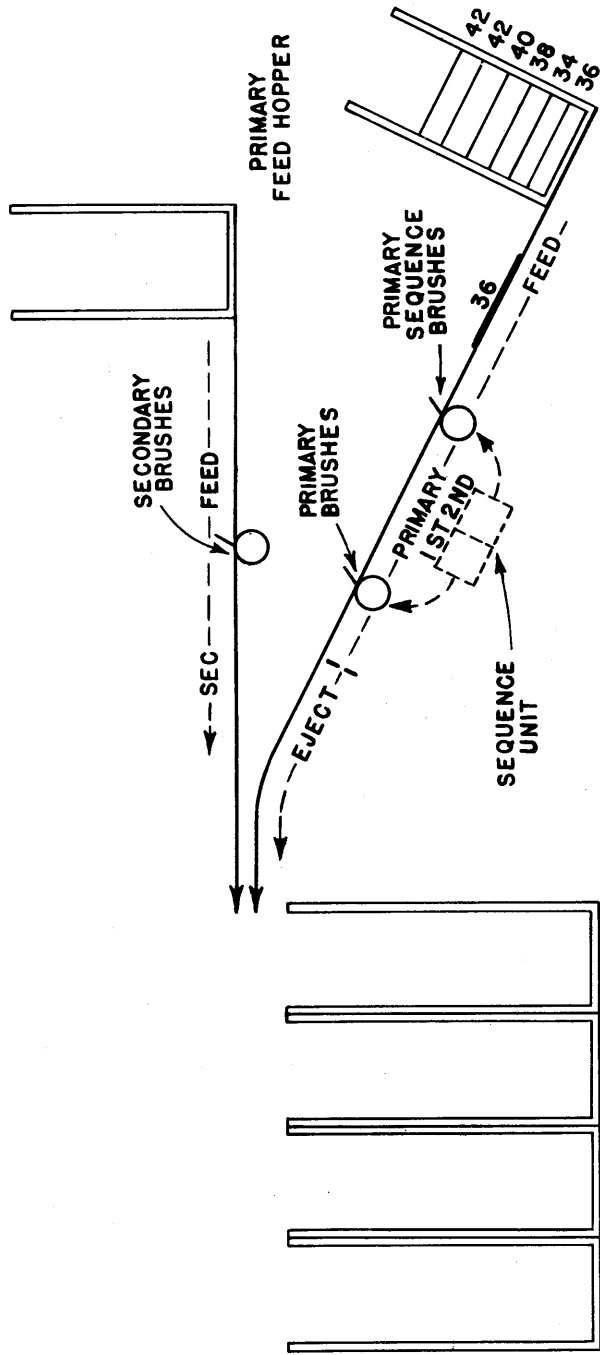

FIG. 12-A

POSITION OF CARDS AT END OF FOURTH CYCLE

SECONDARY
FEED HOPPER

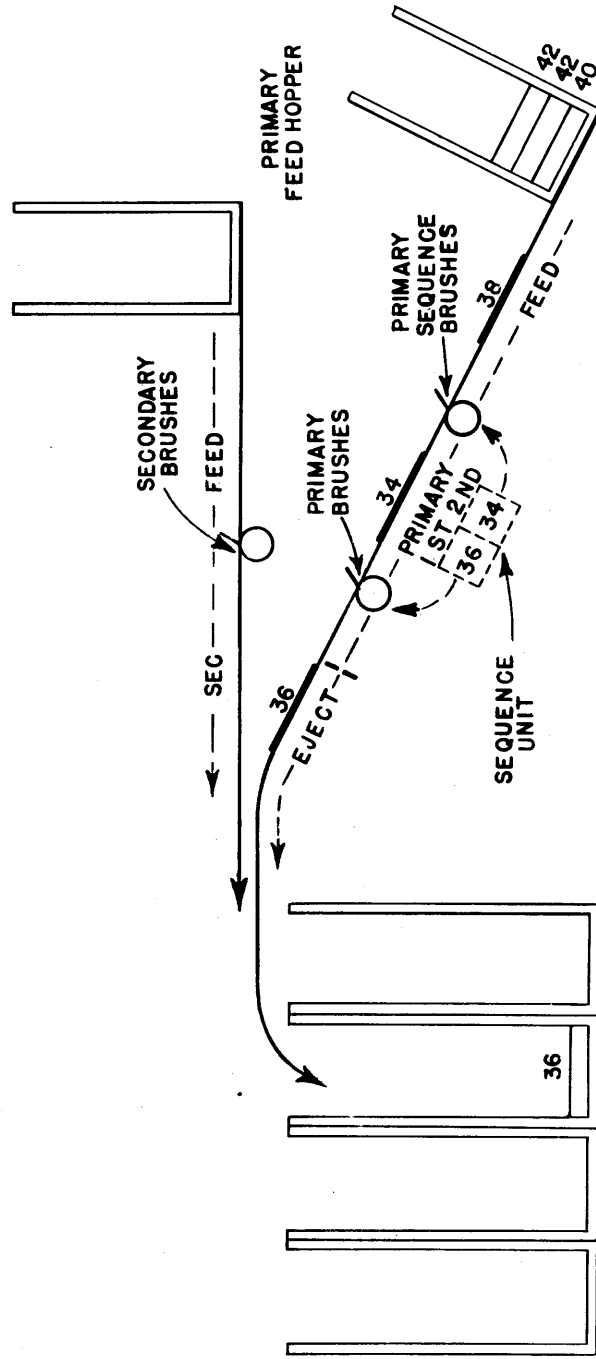

FIG. 15

FIG. 16

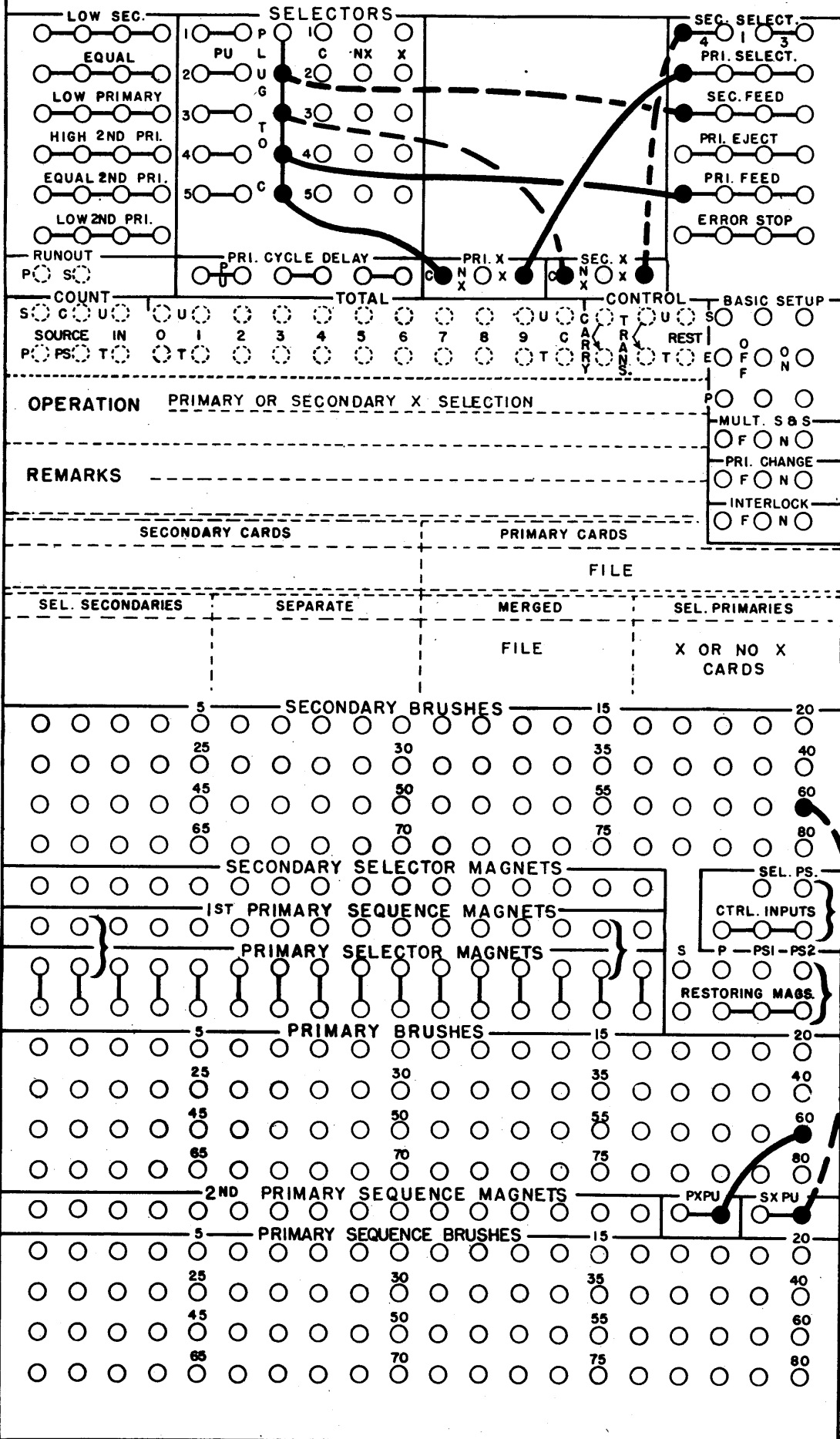
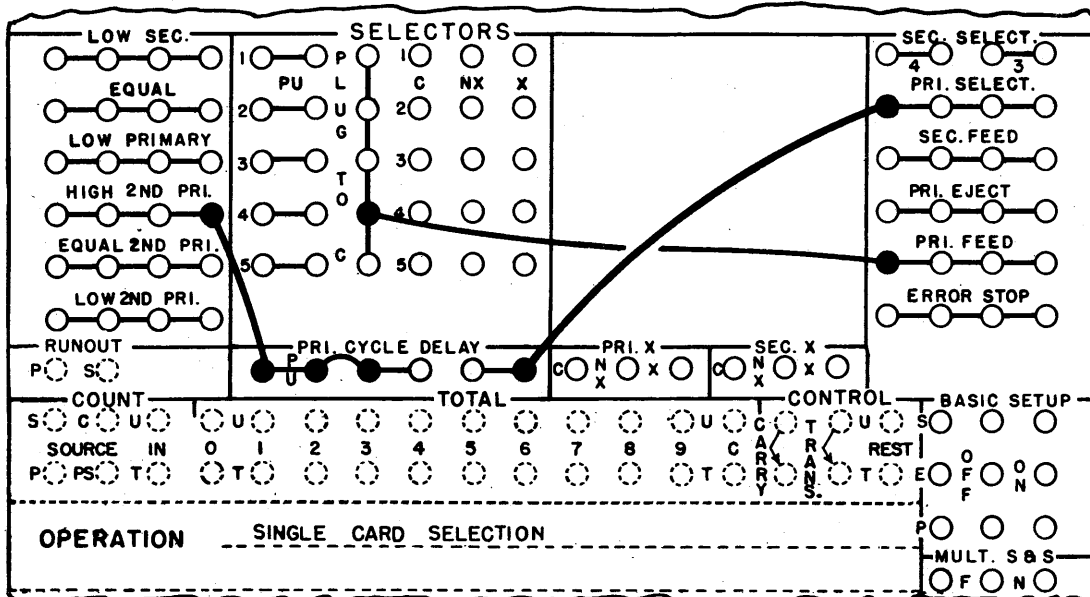
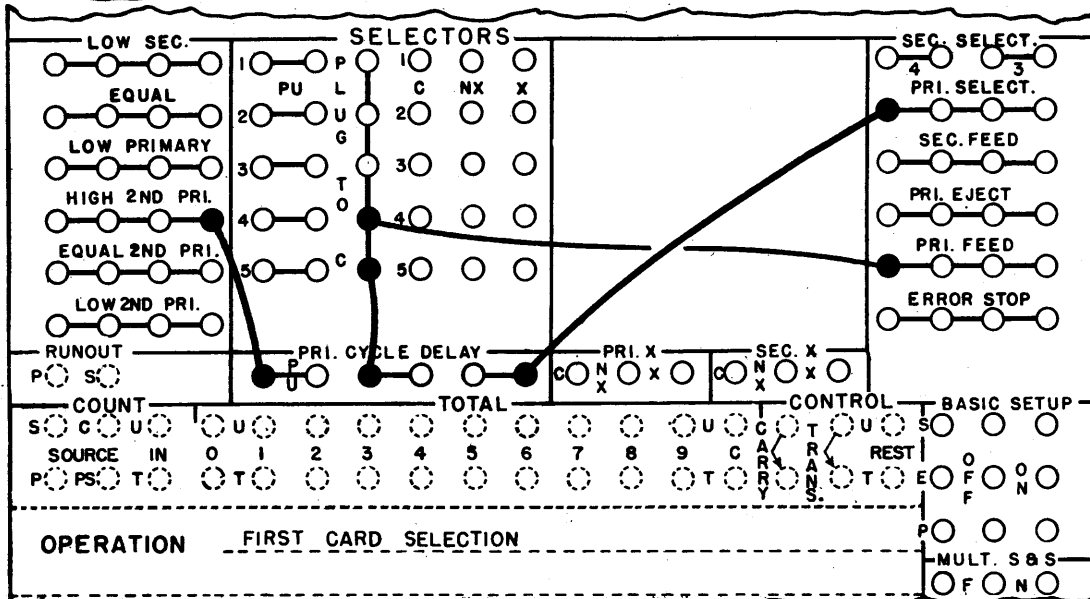
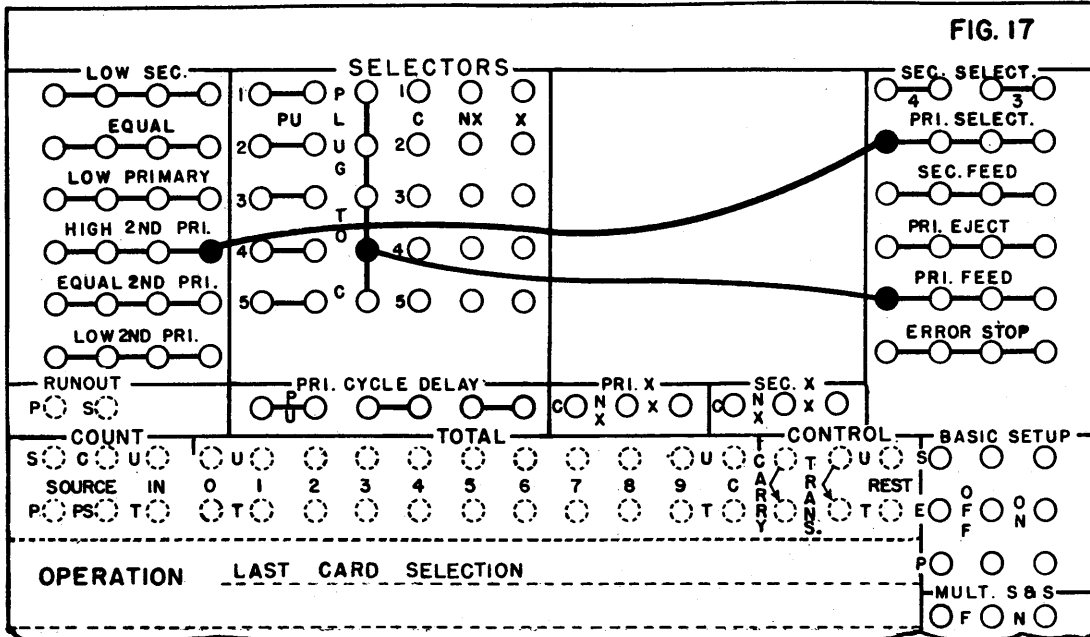

FIG. 17



SECONDARY
FEED HOPPER

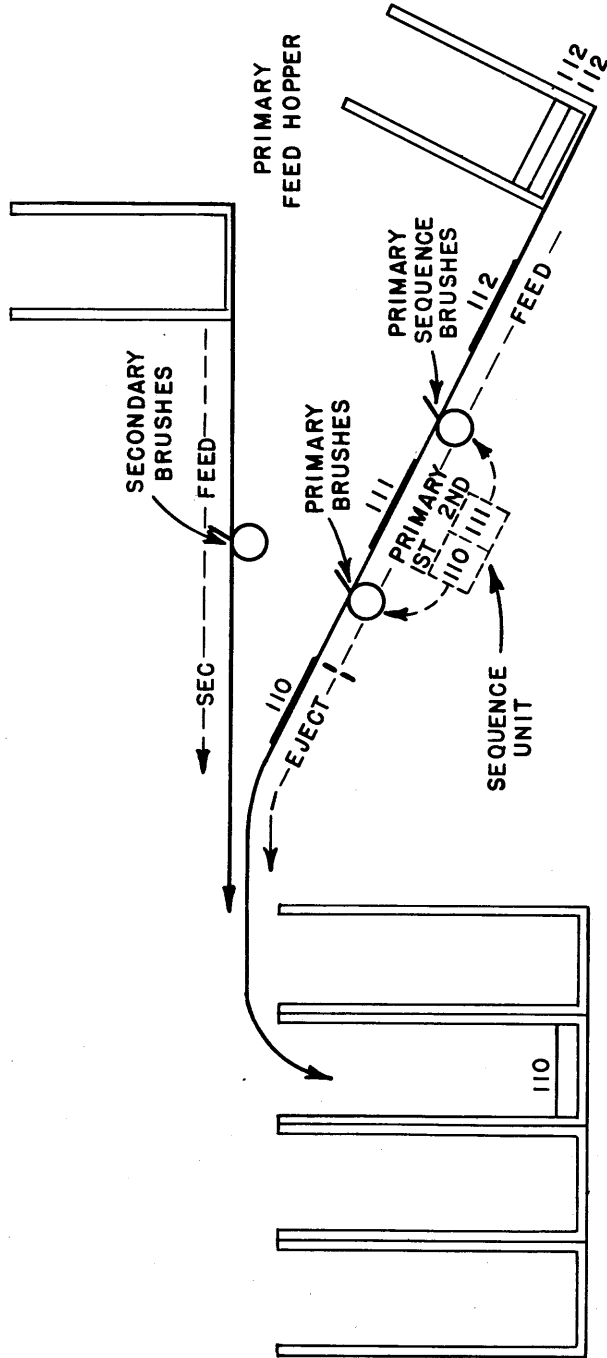
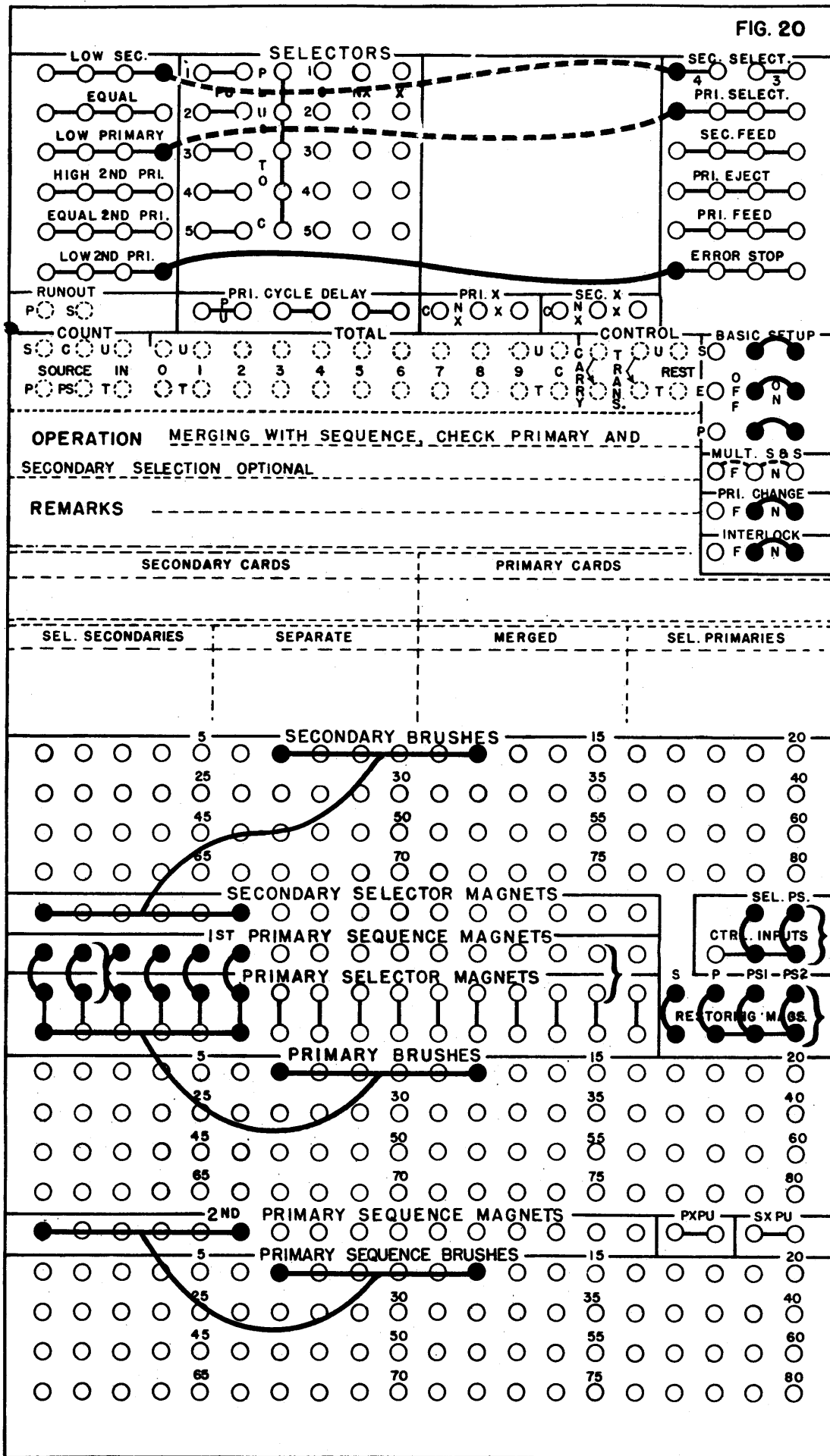

FIG. 19

FIG. 20



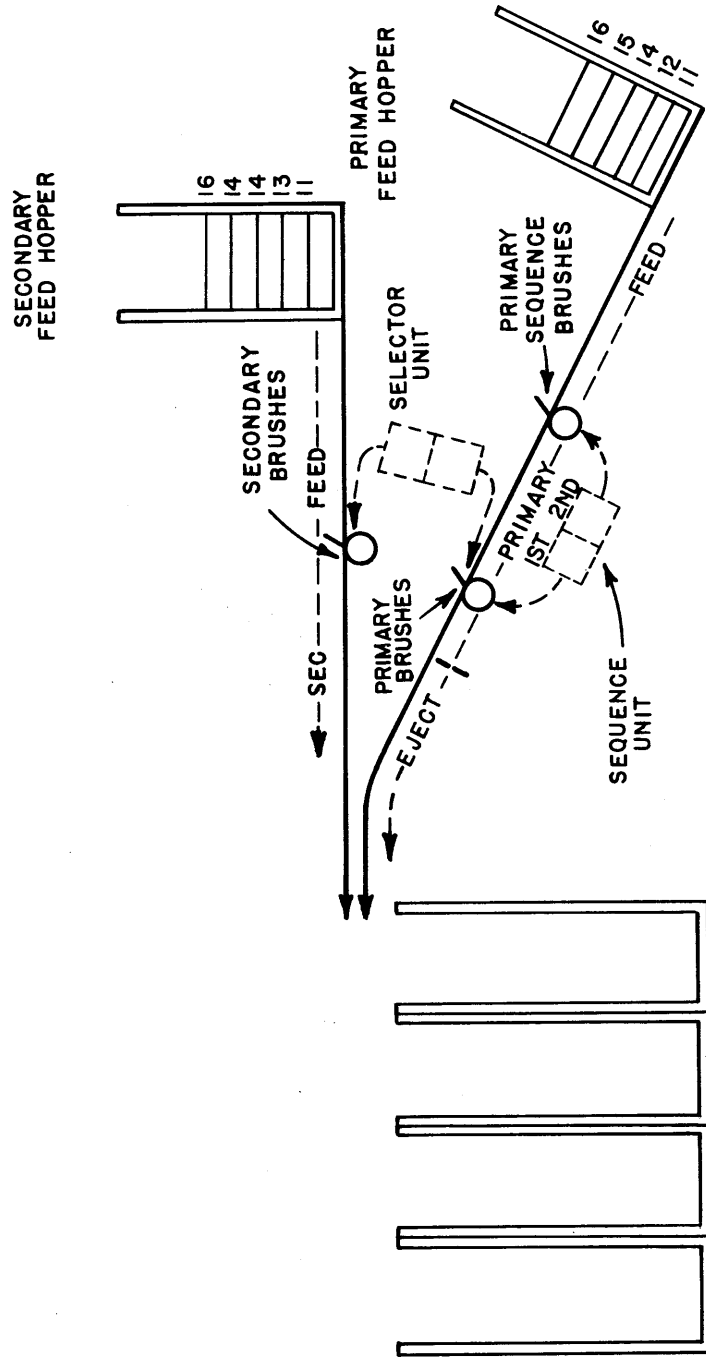

FIG. 21

POSITION OF CARDS AT END OF FIRST CYCLE

SECONDARY
FEED HOPPER

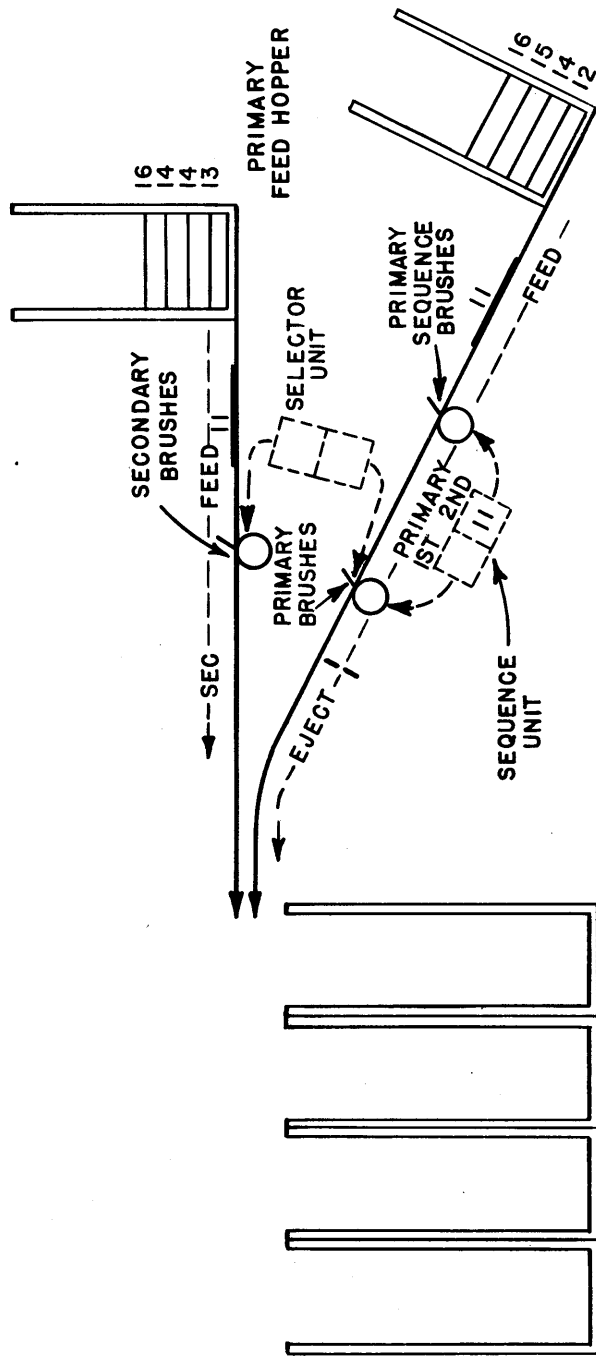

FIG. 22

POSITION OF CARDS AT END OF SECOND CYCLE

SECONDARY
FEED HOPPER

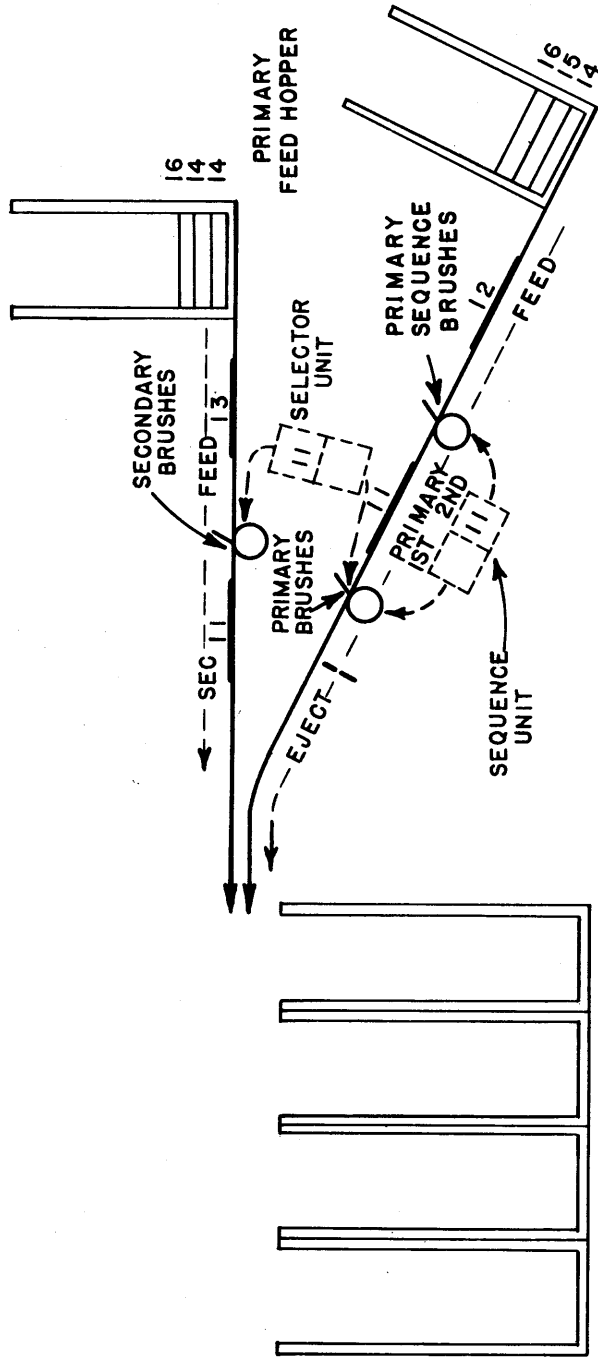

FIG. 23

POSITION OF CARDS AT END OF THIRD CYCLE

SECONDARY
FEED HOPPER

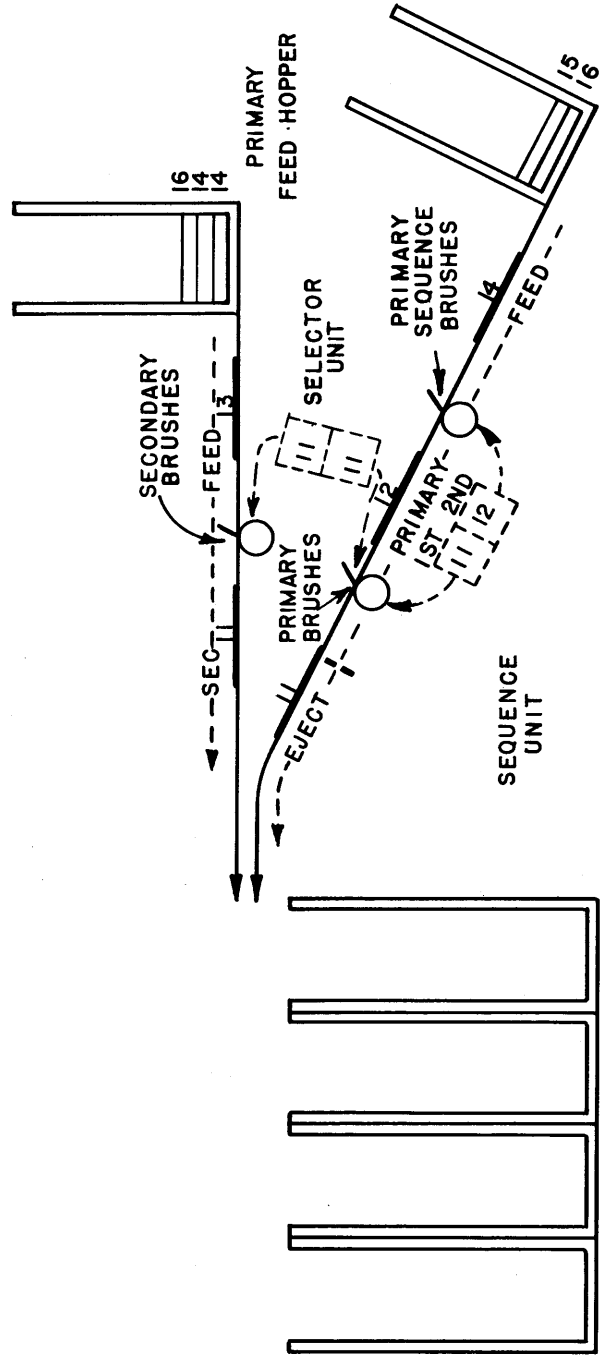

FIG. 24

POSITION OF CARDS AT END OF FOURTH CYCLE

SECONDARY
FEED HOPPER

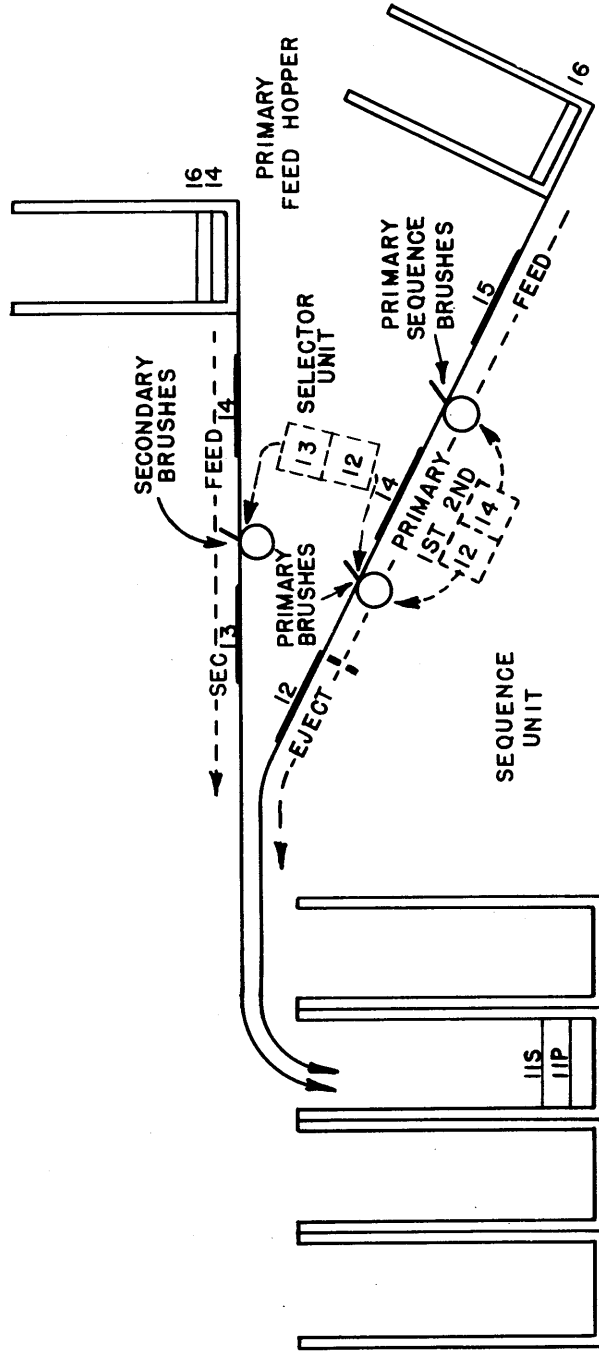

FIG. 25

POSITION OF CARDS AT END OF FIFTH CYCLE

SECONDARY
FEED HOPPER

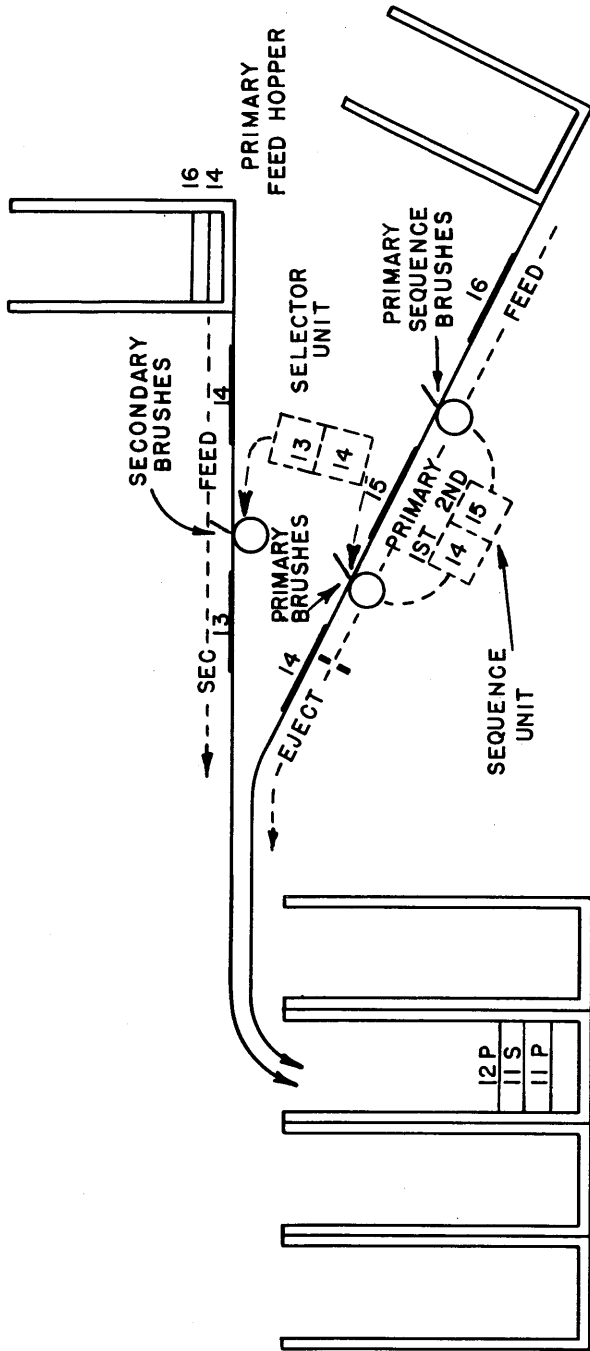

FIG. 26

POSITION OF CARDS AT END OF SIXTH CYCLE.

SECONDARY
FEED HOPPER

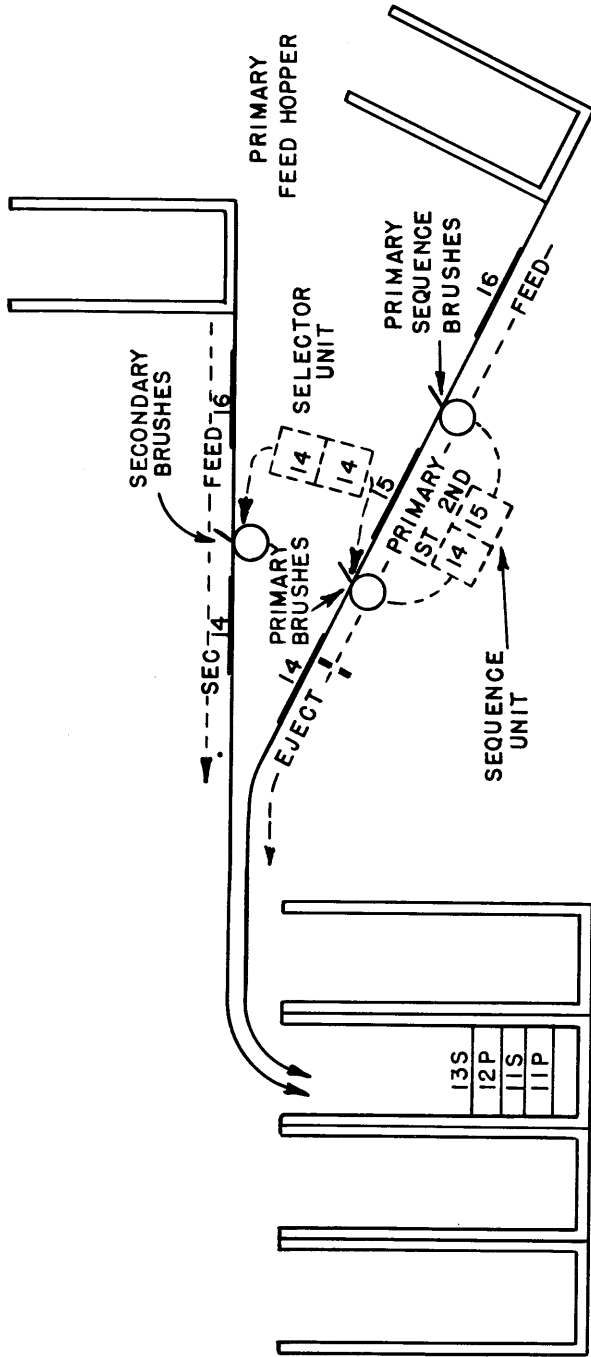

FIG. 27

POSITION OF CARDS AT END OF EIGHTH CYCLE

SECONDARY
FEED HOPPER

PRIMARY
FEED HOPPER

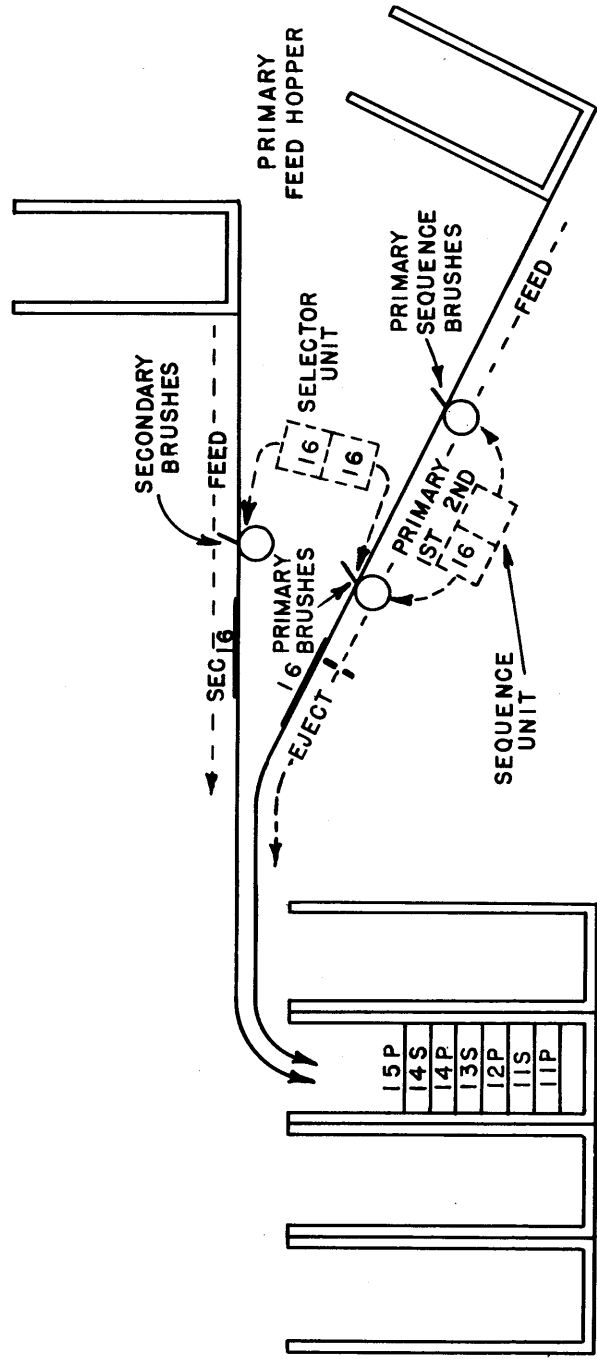

FIG. 29

POSITION OF CARDS AT END OF NINTH CYCLE

SECONDARY
FEED HOPPER

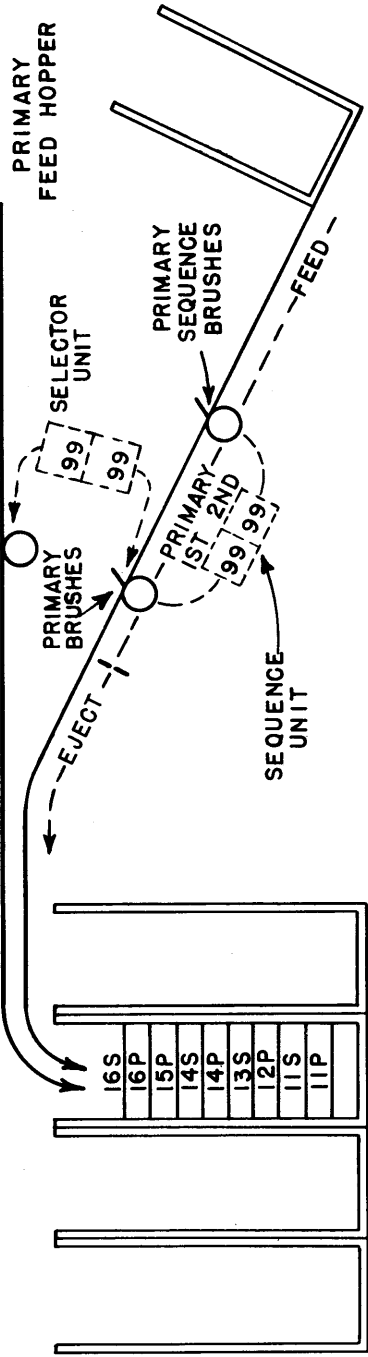
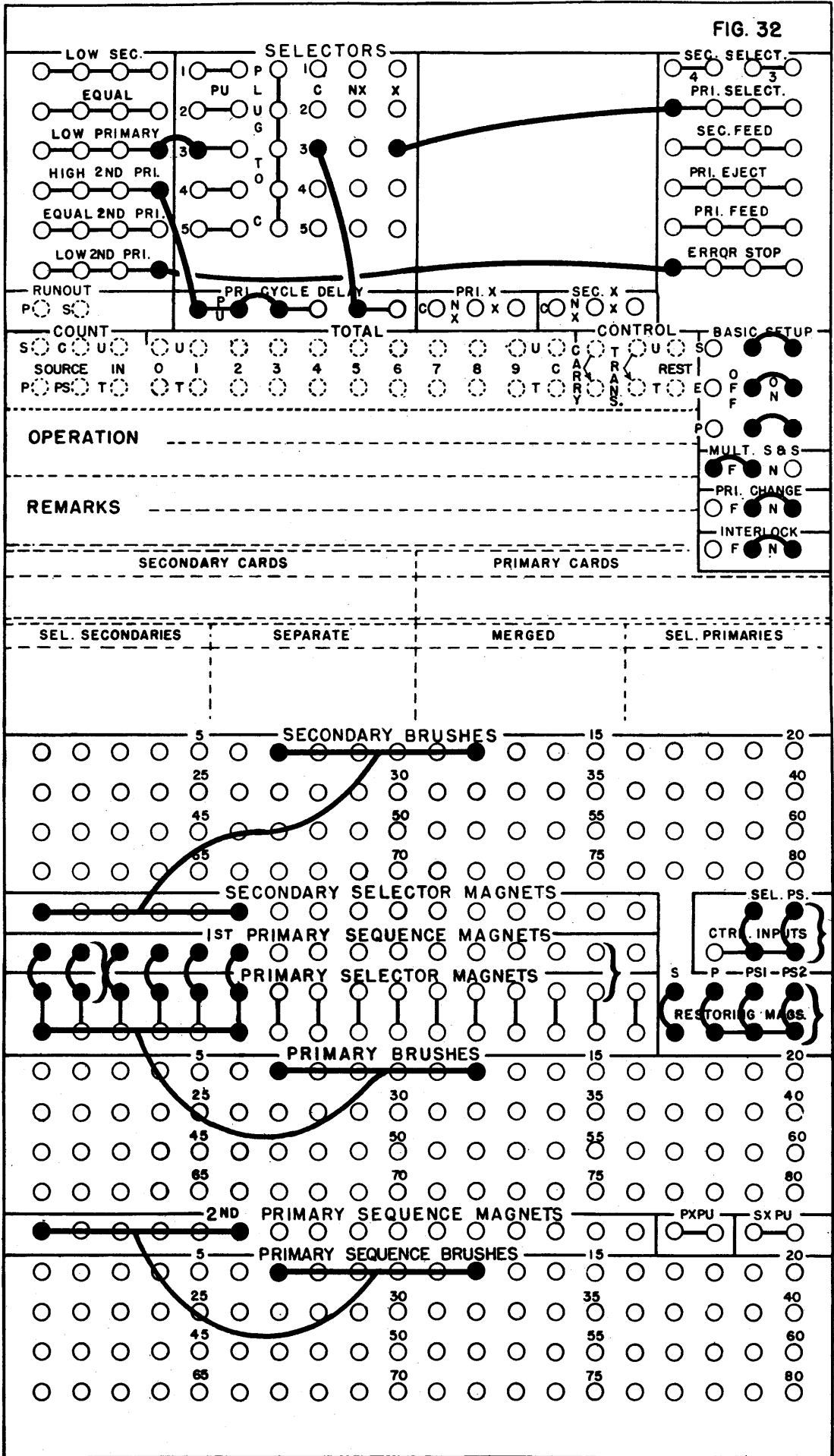

FIG. 30

FIG. 32



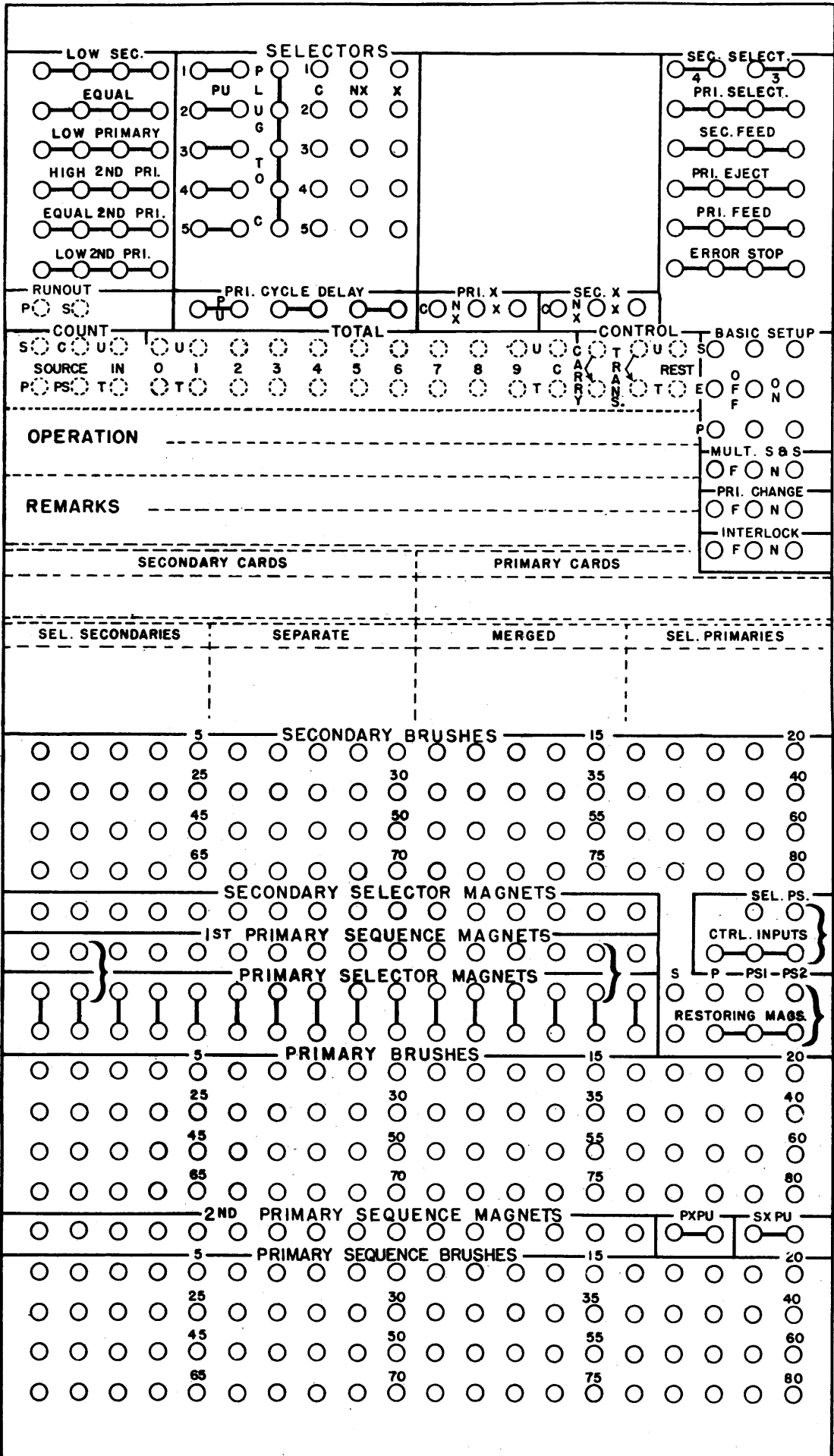

FIG. 34

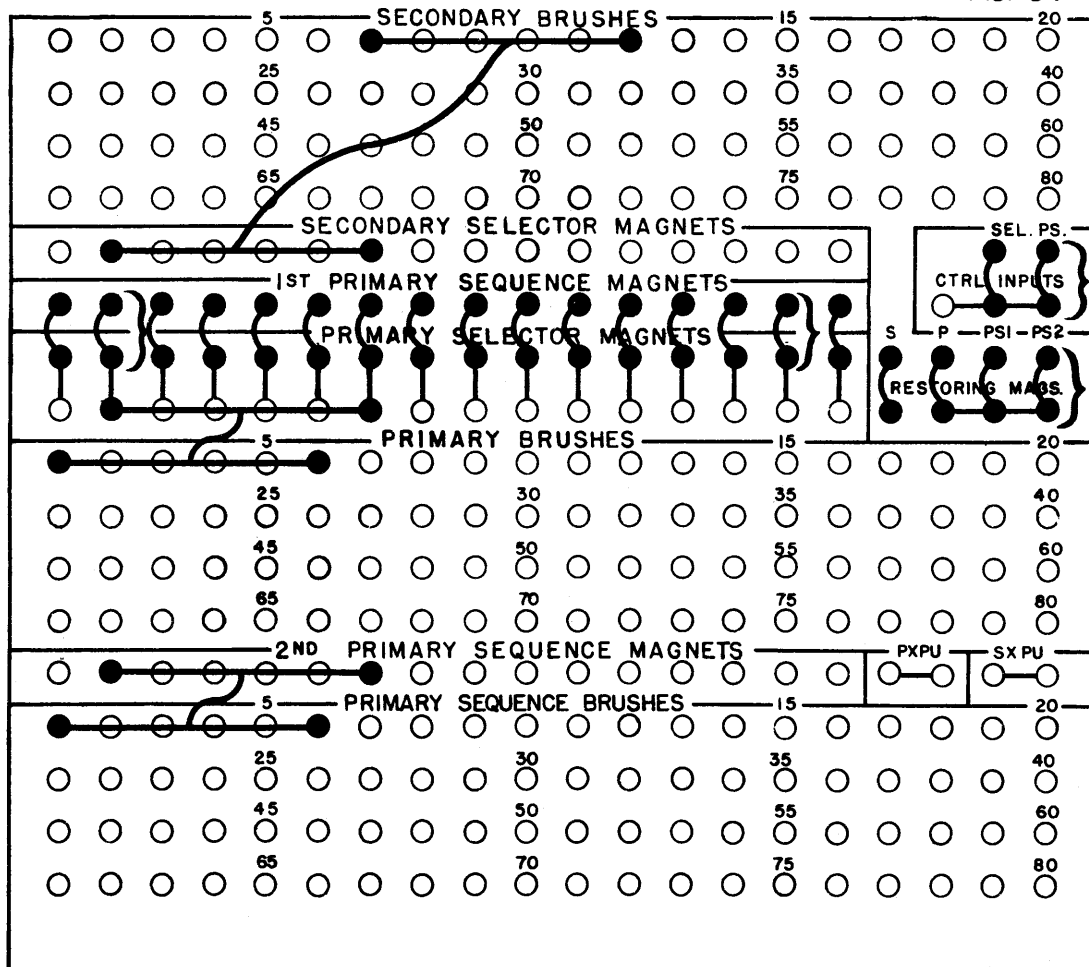

FIG. 35

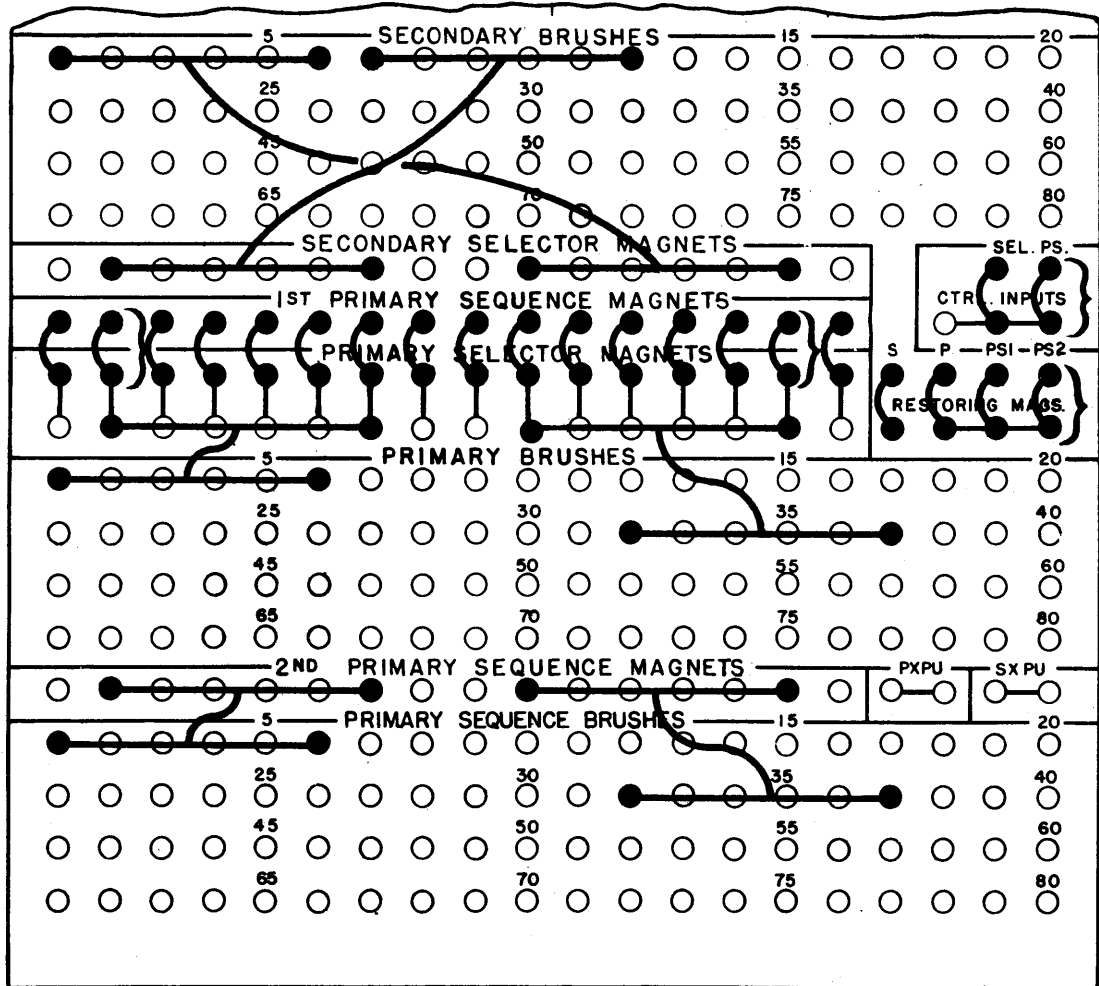
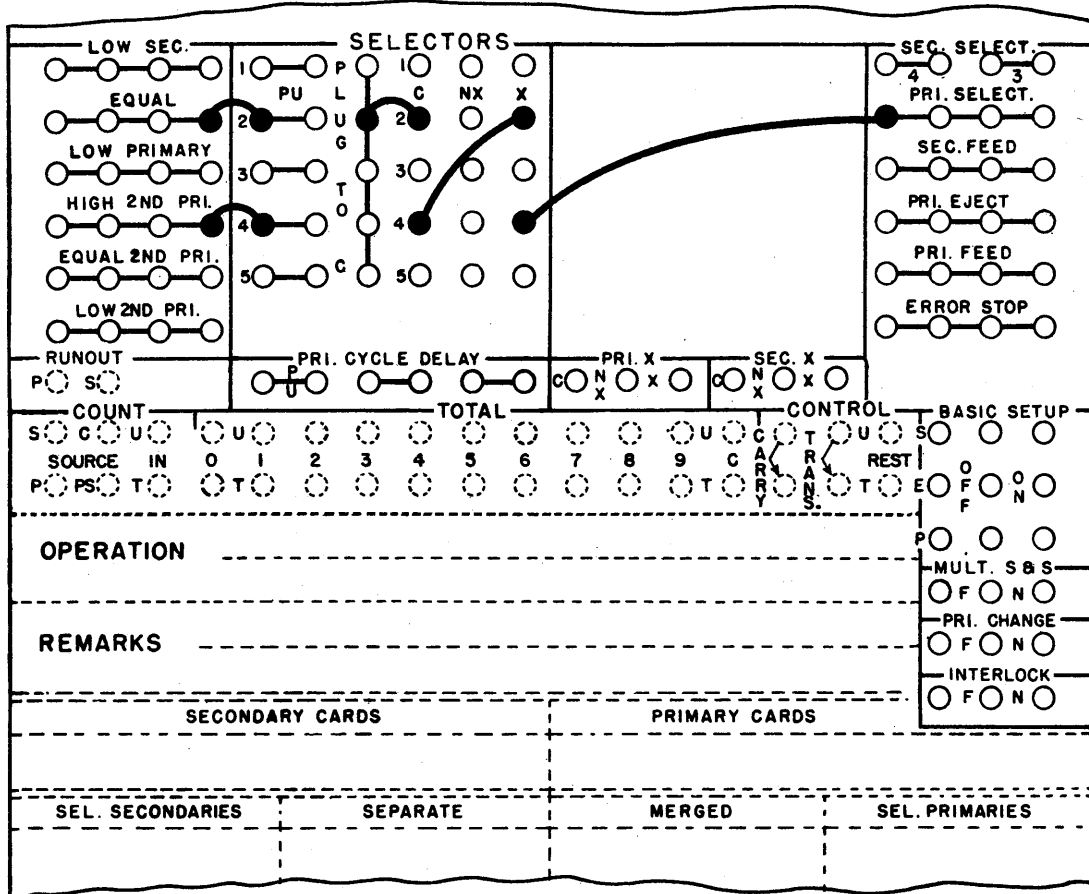
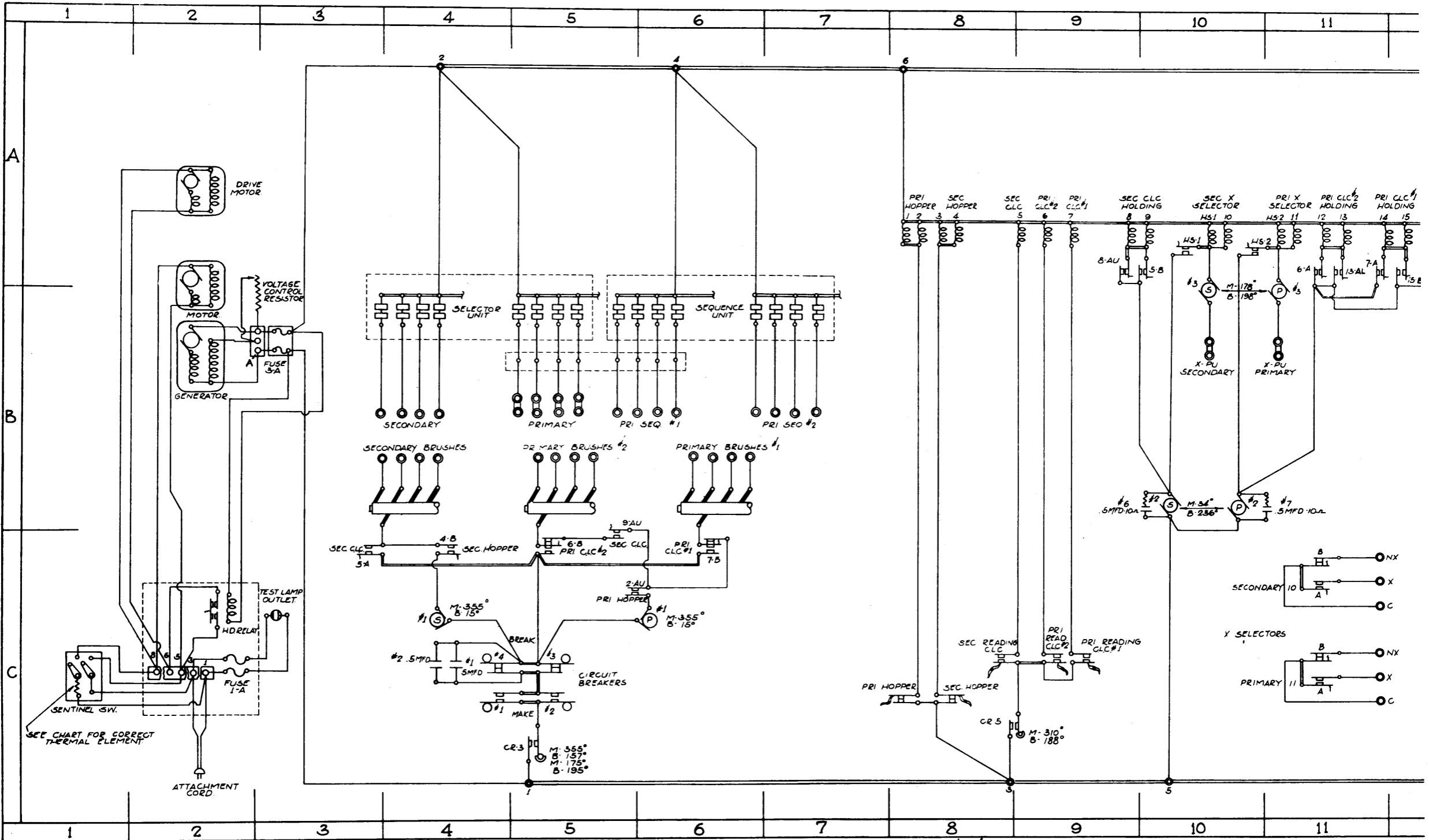

FIG. 37





THERMAL ELEMENT CHART

POWER SUPPLY				THERMAL ELEMENT	
VOLTS	CYCLE	PHASE	AC/DC	AMP.	PART NO.
110			DC	5.8	143358
220			DC	2.7	143327
110	60	1	AC	9.6	143396
110	50	1	AC	10.9	143397
110	25	1	AC	8.5	143385
220	60	1	AC	5.1	143351
220	50	1	AC	5.8	143358
220	25	1	AC	4.5	143345

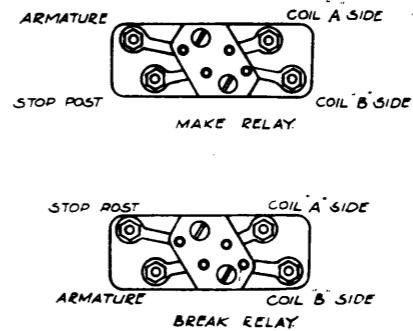
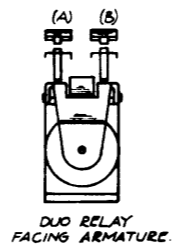

RELAY NO.	PJ COIL	N COIL	AL POINT	AU POINT	BL POINT	BU POINT	RELAY NO.
1	8-A		14-B	13-B	15-B	13-B	24
2	8-A		17-A	6-C	15-B		25
3	8-A		14-B	13-B	15-B	15-B	26
4	8-A		17-A		4-C		27
5	9-A		5-C		10-A		28
6	9-A		11-A		5-C		29
7	9-A		11-A		6-C		30
8	9-A		14-B	9-A	15-B		31
9	10-A		14-B	5-B	17-A		32
10	10-A		11-C		11-C		33
11	11-A		11-C		11-C		34
12	11-A		16-A	16-A	15-B	13-B	35
13	11-A		11-A		17-A	14-C	
14	11-A		15-B	16-A	15-A	17-A	
15	12-A		16-B		12-A	14-B	
16	12-A	12-A	12-A		23-C		
17	13-A	14-A	14-A	14-A	16-C		
18	13-A		15-B		13-A		
19	13-A		18-A	18-A	18-A		
20	14-A		20-B		19-B		
21	15-A	15-A	15-A		13-B		
22	15-A		16-B		15-B		
23	15-A		16-B		16-B		

ELECTRICAL TIMING

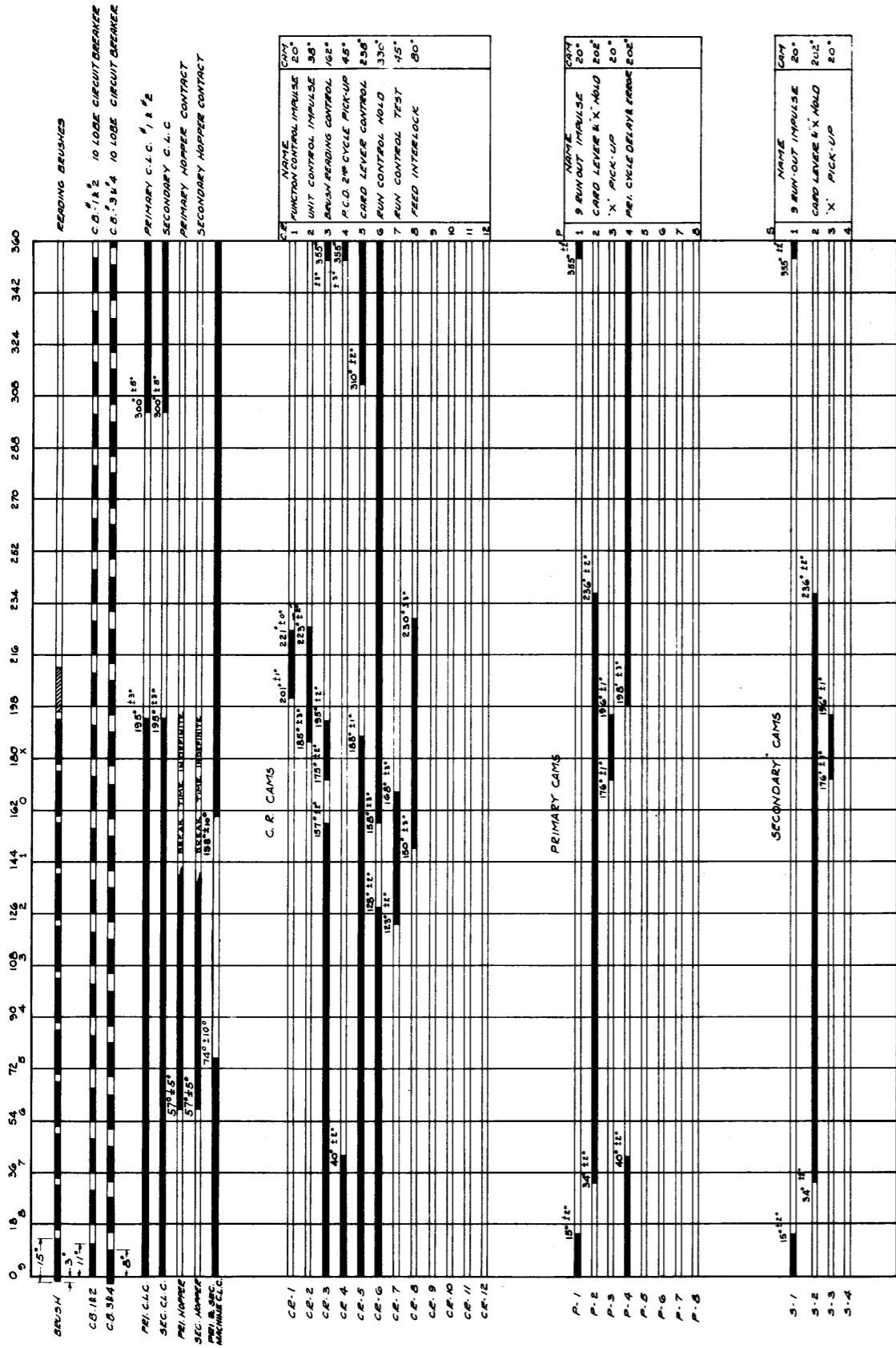

MECHANICAL TIMING

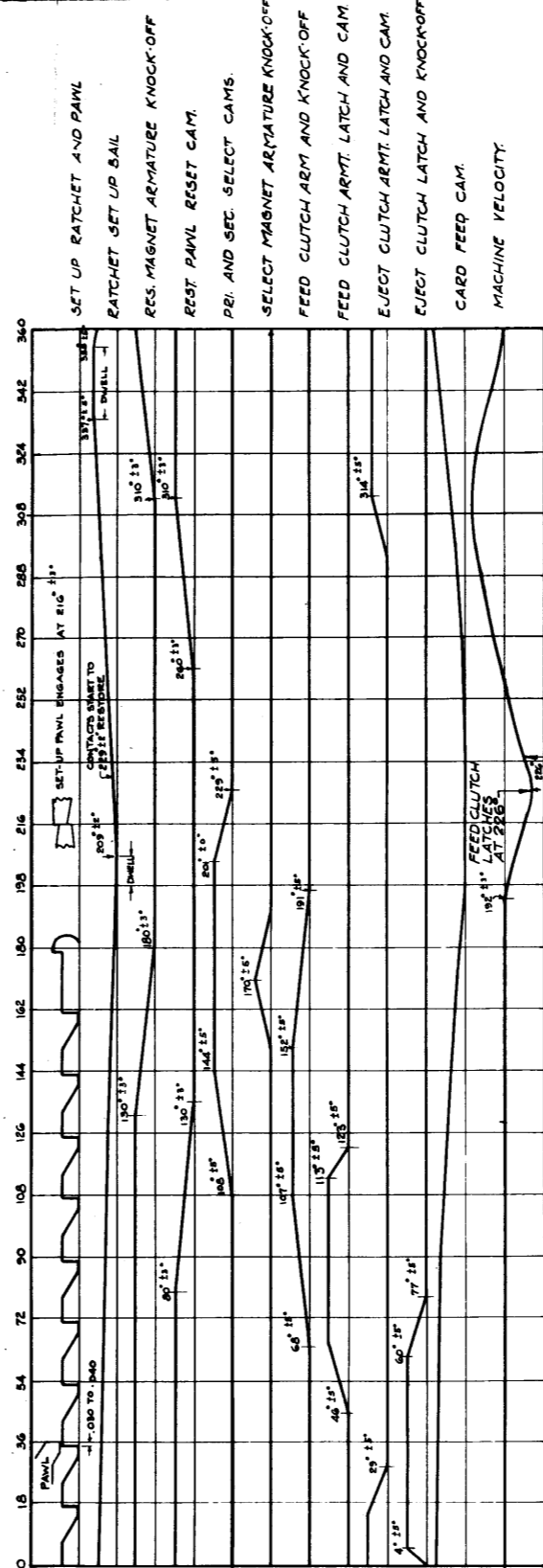

NORMALLY LATCHED UP
FOLLOWS CAM WHEN MAGNET
IS ENERGIZED.

FOR ACTUAL CONTACT DURATION
OF CAMS IN CONSTANT SPEED
RELATION TO CONSTANT SPEED
CHART BELOW.

RELATION OF INDEX TO CONSTANT SPEED CAMS

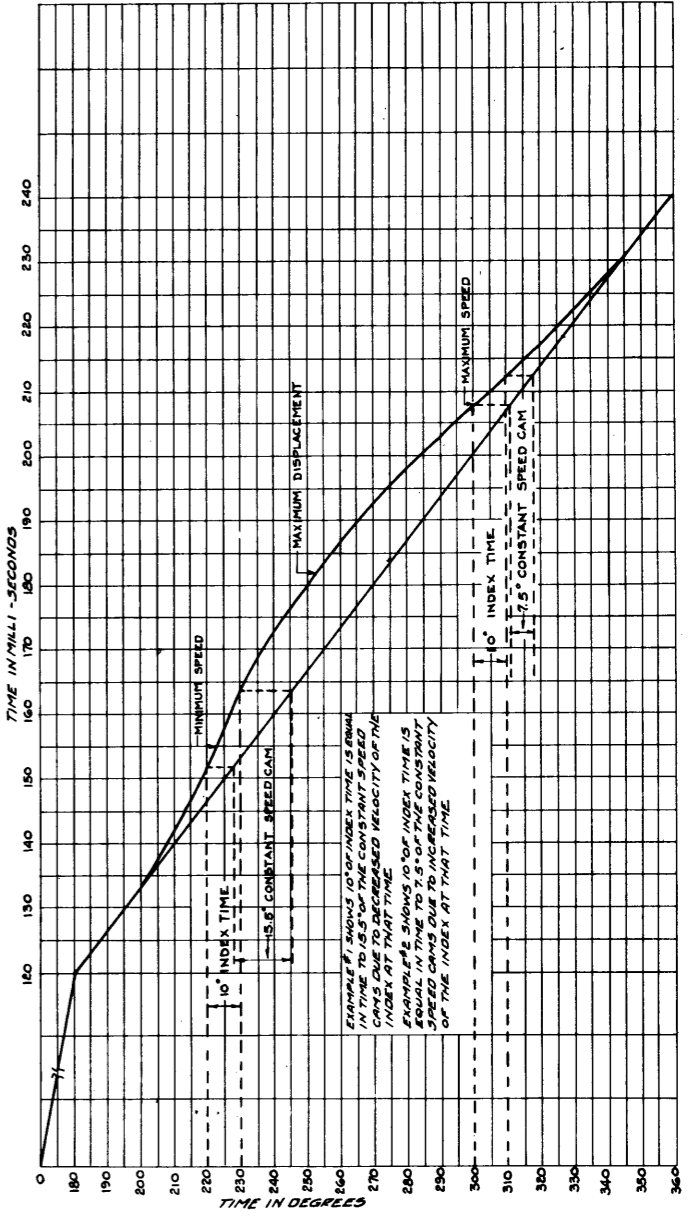

NOTE:
IN DESIGNING NEW CAMS OR CHANGING
TIMING OF EXISTING CAMS, REFERENCE TO
THIS SHEET IS FOR CORRECT DESIGN
INFORMATION.

FIG. - 39