

CIRCUIT BREAKERS



Circuit Breakers and Cam Contacts Preventive Maintenance and Adjustments

CONTENTS

	<i>Page</i>
GENERAL PREVENTIVE MAINTENANCE AND ADJUSTMENTS..	2
ROCKER ARM CIRCUIT BREAKER.....	2
PLUNGER CIRCUIT BREAKER	4
MASTER CIRCUIT BREAKER, TYPE 407.....	11
SPRING STRAP CAM CONTACT	12

Circuit Breakers and Cam Contacts

General

The proper inspection, lubrication and adjustment of circuit breakers and other electrical timing devices is becoming more important because of higher machine speeds and because of the use of circuit breakers in electronic circuits. The impulse duration has, in some cases, been reduced to a relatively short impulse with a very limited tolerance.

A high resistance short caused by dirt or carbonized oil between the circuit breakers may be the cause of intermittent failures in electronic circuits, while in a relay or magnet circuit this same short might not cause any trouble.

If the circuits are to perform their functions properly, it is imperative that the circuit breakers and cam contacts receive regular and thorough preventive maintenance.

When an adjustment is necessary, the circuit breakers should first be cleaned, inspected, and lubricated, using the procedure outlined for each type.

A complete row of circuit breakers with the wires attached can, in most cases, be loosened and moved out from the machine for easier cleaning and inspection. Take care that the wires are not stretched, broken, or pulled loose from the circuit breaker terminals. Do not allow circuit breaker assemblies to be supported only by the wires at any time.

Circuit breakers should be cleaned thoroughly using an authorized solvent to remove all old oil, grease and dirt. Be careful to clean the spaces between circuit breakers and to clean the insulating strips in the contact pile-ups.

Grasp each row of circuit breaker cams and attempt to rotate the shaft in one direction and then the other, checking the gear train for play. The only play that is allowable is caused by the normal wink between the gears. If the play seems to be excessive, check carefully to determine the cause.

When the contacts are timed, the end of the cam duration which has the degree given on the timing chart is to be accurately set. This may be either the make or the break time for the contact. A split-block adjustment is provided on the drive gear of most units to allow all the cams to be timed more closely than could be done by moving the drive gear one full tooth. The split block should be adjusted only if the majority of circuit breakers requires the same amount of change in timing.

Use a dynamic timer to check the make or break timing and the duration whenever it is possible to use one. Reference should be made to customer engineering manual *Meters and Test Devices* (Form 22-8788-1) for complete instructions concerning the use of the dynamic timer. The dynamic timer gives an accurate picture of the duration only. It does not show contact condition. An ohmmeter should be used to determine the quality of the circuit through the connecting wires and contact points. Machine power must be OFF when using a test light or an ohmmeter.

The screws holding the contact pile-ups, the brass jumpers, and the wire terminals should be checked for tightness.

The adjustments for each type of circuit breaker are listed in the order in which they should be made.

A new customer engineering reference manual, *Meters and Test Devices*, Form 22-8788-1 describes the method used to check circuit breaker impulses with an oscilloscope. If such a device is available, it can give an accurate picture of the circuit breaker impulse.

ROCKER ARM CIRCUIT BREAKER

Preventive Maintenance

Use an authorized solvent to clean cam surfaces of all old grease and dirt. Check to see that the cam is not loose, warped, or eccentric.

Cam rollers should be checked to see if they are loose or binding. Replace the rocker arm when the roller bearing is bad.

The rocker arm pivot should be checked to see if it is loose or binding. Replace the rocker arm when the pivot bushing is worn.

Circuit breakers should be cleaned with an authorized solvent. If the points are badly pitted, replace them. When it is necessary to use an abrasive on circuit breaker points, it is recommended that a folded strip of trimate paper be used. After cleaning with a solvent or with an abrasive, make certain that all particles have been removed from the contact surfaces. A good method to follow is to rub the surfaces with a finger and then to polish thoroughly with a burnishing tool.

A rocker arm is available that has a removable point. It is to be used in positions where frequent replacement of points is necessary. The part numbers of the arm and point are: contact breaker arm 198248; contact point (only) 198247; nut 27073; lock washer 6364; circuit breaker arm (only) 198275.

Check the screws holding the contact pile-ups for tightness.

Make certain that the contact surfaces are parallel and that they meet squarely.

If any of the rocker arms seem to have noticeably less spring tension than the others, replace them.

When any of the component parts of the circuit breaker assembly are replaced, the adjustments should be checked.

Lubrication

IBM 6

- (1) The cam follower roller.
- (2) The rocker arm pivot.

IBM 17

- (1) A very light film on the cam surface.
- (2) The cam follower roller (apply IBM 6 first).

Exercise caution in lubricating contact assemblies. Where the contact points are lower than the pivot point, too much lubricant should not be used, because it will run down the arm and may prevent the points from making contact.

Adjustments

1. Align the points so that the sides and faces are parallel (Figure 1).

2. The cam follower roller must be clear of the cam surface when the points are closed (Figure 1).

3. With the cam follower roller on the high surface of the cam, set the contact air gap with the adjustable contact point as specified on the electrical timing chart for the machine (Figure 2). On some older machines the correct air gap must be obtained from the customer engineering manual of instruction.

4. Loosen the setscrews in the circuit breaker cam (Figure 2), and turn the cam to obtain the proper timing as specified on the electrical timing chart for the machine. Use a dynamic timer whenever possible to check the timing of the circuit breaker contacts. Be sure to tighten the setscrews if they have been loosened.

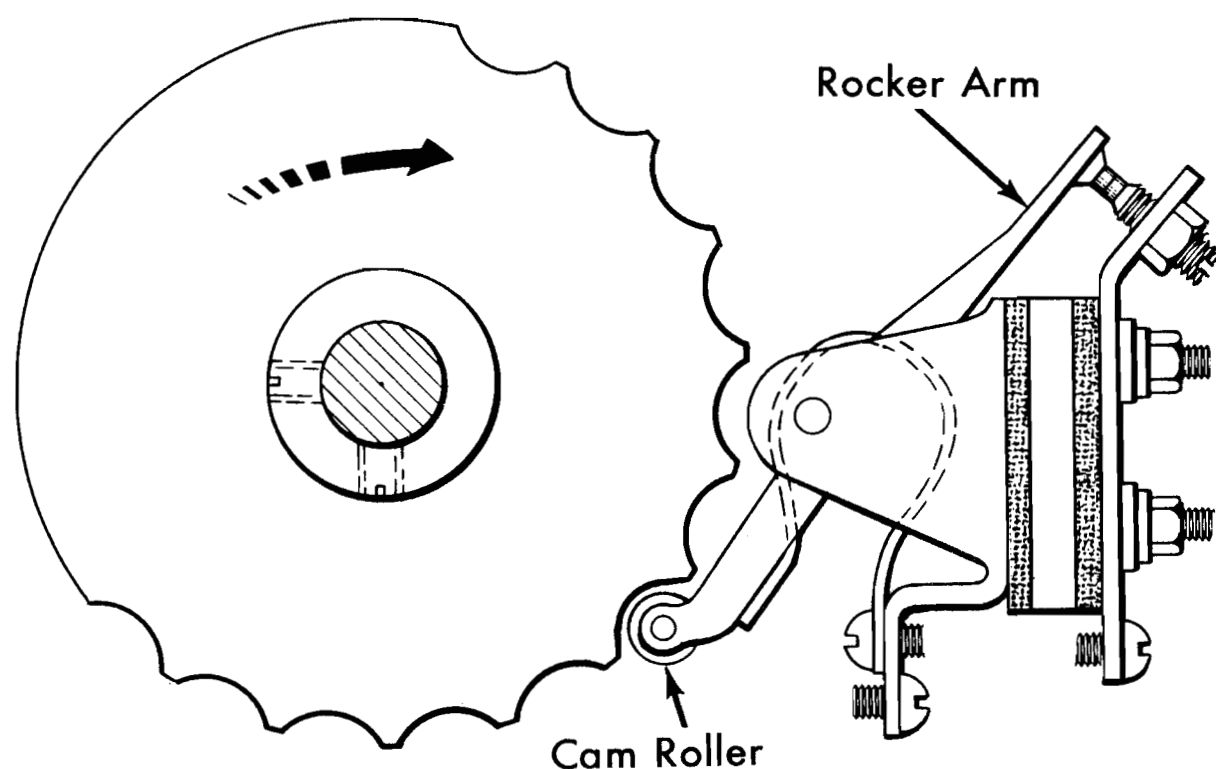

Figure 1. Rocker Arm Circuit Breaker Adjustments 1 and 2

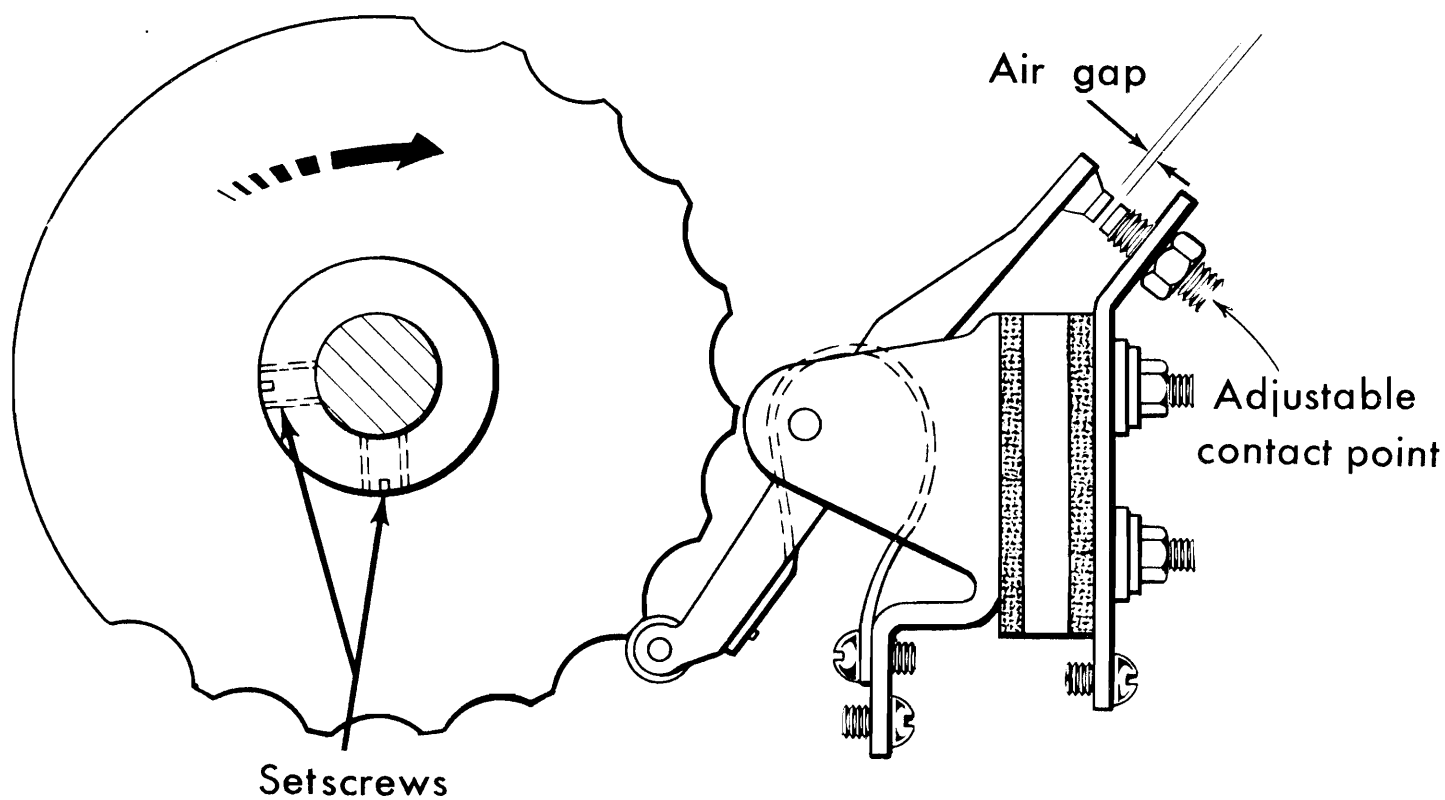

Figure 2. Rocker Arm Circuit Breaker Adjustments 3 and 4

PLUNGER CIRCUIT BREAKER

Preventive Maintenance

Inspect for a build-up of carbonized oil or other foreign material which could cause a short circuit between the contact straps. This accumulation will occur around the points and between the straps.

The plunger type circuit breakers cannot be properly cleaned in the machine. The complete contact bar assembly can usually be removed from the machine with the wires attached. These bars are not doweled, so it is necessary to use some means of determining that they are reinstalled in the same position from which they were removed. One method is to check the timing of a few cams on each end before the bar is removed. Then reinstall the bar so that these cams have the same timing that they formerly had.

When the circuit breaker assemblies are removed from the machine, they should be flushed out with an authorized solvent. Be very careful not to damage the wires and cables. The circuit breaker assemblies should never be supported by wires alone.

This cleaning procedure must be repeated periodically to reduce the possibilities of machine failure by minimizing the accumulation of dirt and carbon. The recommended maximum length of time between cleanings is six months. When compressed air is available, it should be used to blow the solvent out of the circuit breakers after cleaning.

A burnishing tool should be used to polish the circuit breaker points after they are cleaned. This will remove any particles or any film that is left by the cleaning process. A new burnishing tool, part 450567, is available. It can be used to burnish normally closed and normally open plunger type circuit breaker points.

Check the cable connections to the circuit breakers. Screws holding the brass jumpers and contact pile-ups should be tightened periodically. The taper plugs that plug into the circuit breaker contact block may become loose due to vibration or movement of the cable. They should be tightened using long nosed pliers.

Circuit breakers with badly pitted points or with worn plungers should be replaced as an assembly. It is not advisable to change component parts. The contact tension must be exact if the circuit breaker is to operate correctly, and this tension cannot be properly obtained by the customer engineer when he replaces the contacts. The plunger has a tendency to stick when it becomes worn. It is, therefore, better to replace the old contact with a new assembly.

Lubrication

Plunger and Latching Plunger Circuit Breakers.

IBM 9

(1) Place a small amount on the contact operating plunger. Never lubricate the plastic contact operating plunger of the roller cam follower circuit breaker.

(2) The pivot of the contact latch of the latching plunger circuit breaker.

IBM 9

(1) On the Type 602A and the Types 402-403 machines the Bijur lines to the felt cam wipers and bearings of the circuit breaker unit should be removed and plugged with the Bijur closure plug, part number 190278. This is done to reduce the amount of oil received by these units. Periodic light applications of IBM 9 on the felt cam wipers will be necessary.

(2) A small amount should be applied to the circuit breaker cam shaft bearings.

(3) Care must be exercised not to over-lubricate the circuit breaker units.

Plunger Circuit Breaker with Roller Cam Follower.

IBM 9

(1) Use sparingly on the roller arm pivot stud.

IBM 12

(1) One drop on each end of the roller shaft.

IBM 24

(1) Apply a light film to the cam surface.

The plastic contact operating plunger of the roller cam follower circuit breaker *should not be lubricated.*

Adjustments — Plunger Type

EITHER a normally open or a normally closed circuit breaker may be used to give the desired contact duration. If the contact duration is to be less than 180°, a normally open circuit breaker is used. The contact will be closed by the cam for the desired time. If the contact duration is to be greater than 180°, a normally closed circuit breaker is used. The contact will be opened by the cam for the number of degrees that the contacts should not be made.

Normally Open Circuit Breaker

1. The lower strap should be formed at point A to provide proper tension. (Figure 3). At the factory these straps are adjusted so that a force of 160 grams plus or minus 10 grams (approximately 6 oz.) applied at the tip of the lower strap will just close the points. This tension must be maintained accurately to prevent

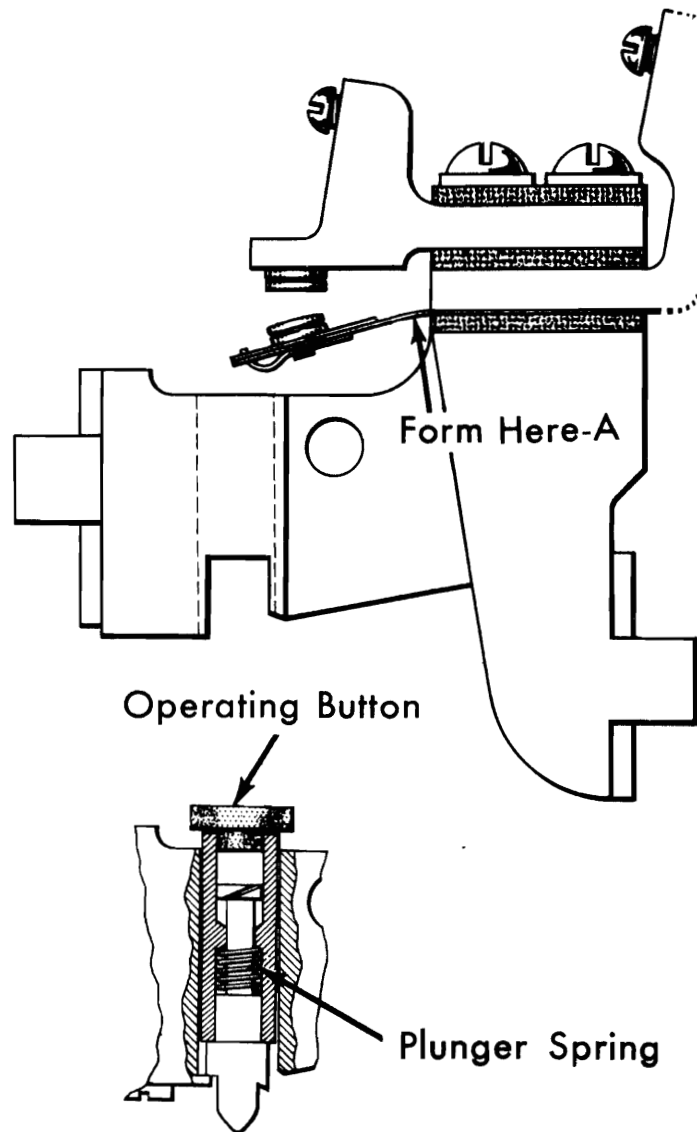

Figure 3. Plunger Circuit Breaker Adjustment 1

2. The upper contact support should be formed at point B (Figure 4) to provide a .015" to .018" clearance between the upper contact and the lower contact when in its normal position resting on the plunger. Before the upper contact is bent, the operating button is installed which gives the closest starting clearance. The white button 205740 is standard; the red button 186882 is .015" shorter.

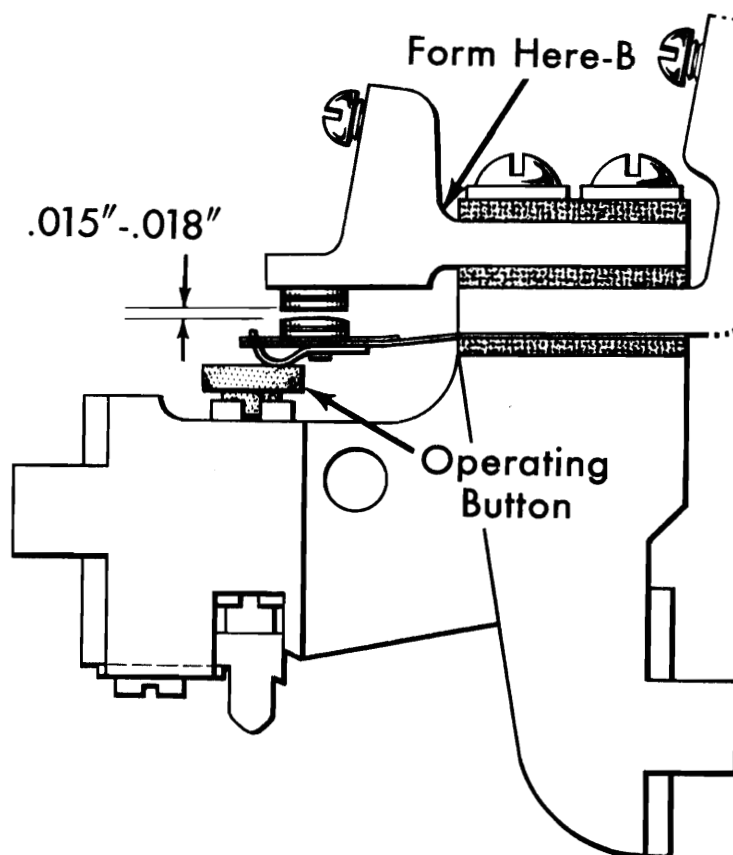

Figure 4. Plunger Circuit Breaker

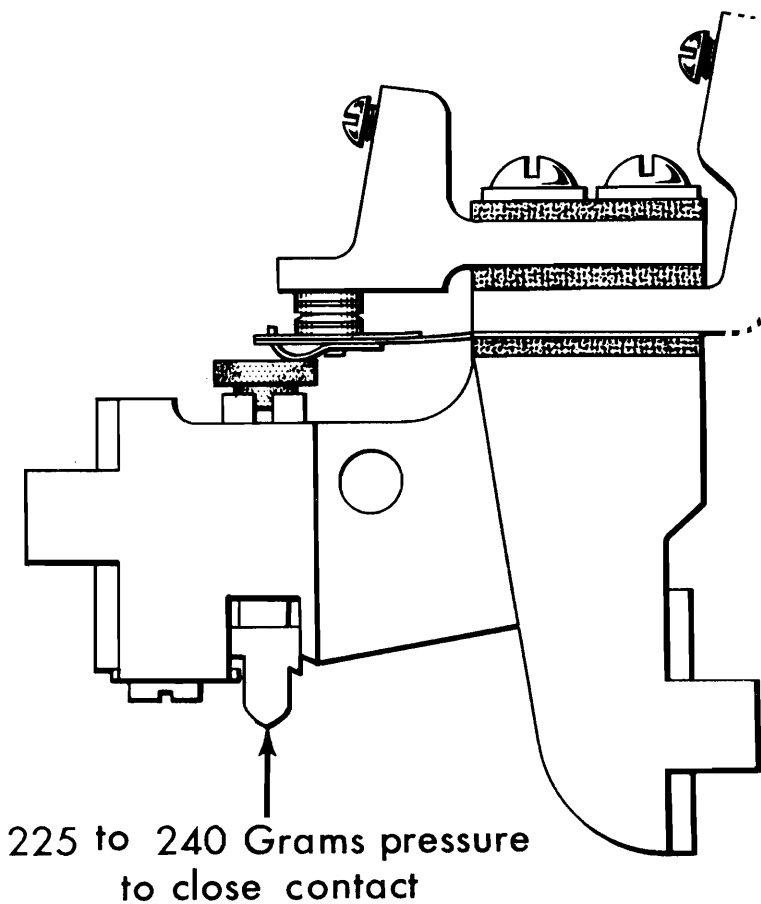

Figure 5. Plunger Circuit Breaker Adjustment 3

3. Check to be sure that the plunger does not bind (Figure 5). The design of the split bushing is such that the coil spring spreads the bushing to create a drag between the bushing and frame which increases the pressure required to close the contact from 160 grams (pressure required to close the contact) to 225 grams (approximately 8 oz.). This friction is used to dampen the rebound when the contact closes. Check to be sure that a maximum of 240 grams applied to the plunger closes the contact.

4. Locate the cam contact unit on the mounting bar with the plunger on the highest point of the cam lobe and the contact points just closed (Figure 6), and advance the adjusting screw one-half turn to obtain a .010" to .015" additional movement of the plunger. The total rise from the low dwell to the high dwell of the cam is .065". With the air gap set for .015" to .018" and the contact assembly correctly located on the mounting bar, the clearance between the cam plunger and the low dwell should not be greater than .018". This may be checked by inserting an .018" gauge between the low dwell of the cam and the plunger and observing any perceptible movement of the contact strap. This indicates that the additional travel of the plunger, after the contact is closed, will be sufficient to compress the plunger spring and provide good contact

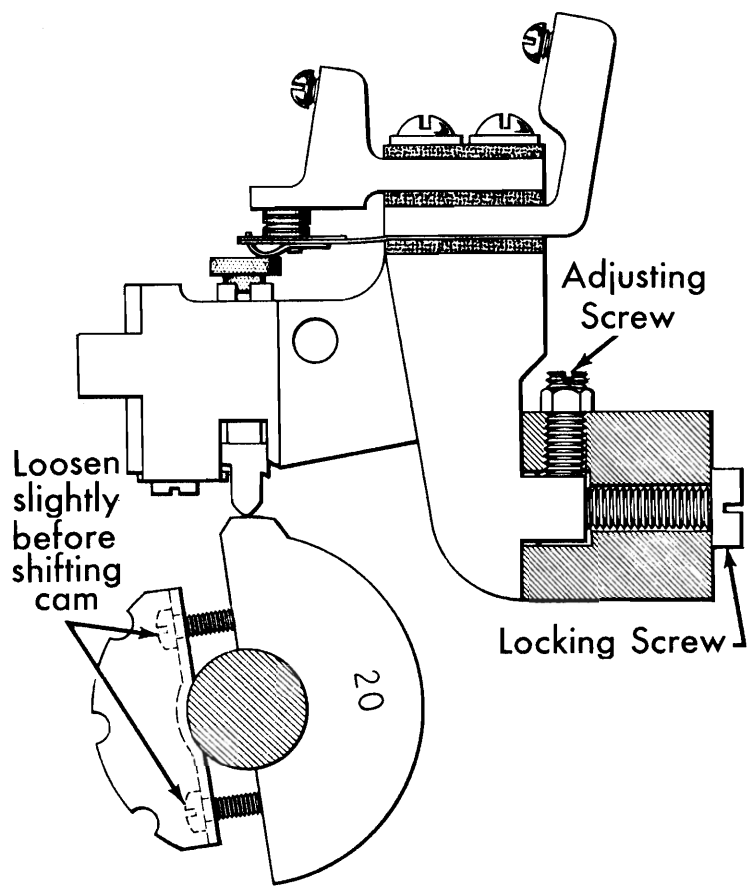

Figure 6. Plunger Circuit Breaker Adjustments 4 and 5

5. To adjust the make time of the contact, loosen the screws holding the cam to the shaft (Figure 6) until the cam is just snug on the shaft. Turn the machine to the index point corresponding with the make time of the cam. Move the cam on the shaft in the direction of rotation until the contact just closes. The machine may now be turned to a point where the cam holding screws can be tightened. The circuit breaker cam clamp is provided with notches and accurate adjustment of the cam may be obtained by tapping lightly against the notch with a screwdriver.

When the cam time duration is of a number of degrees not supplied by a standard cam, an additional adjustment must be made. It will be necessary to raise or lower the contact assembly until the desired condition is satisfied. Check the duration with a dynamic timer after the adjustment is changed. A contact which is dirty or is making with little tension may indicate proper duration on the dynamic timer, yet it may not be capable of carrying a heavier current load such as required to operate one or more relays. Be sure of the contact condition.

Normally Closed Circuit Breaker

The sides of the contact operating button of the normally closed circuit breaker have been cut away to prevent an accumulation of carbon and dirt at the contact points which

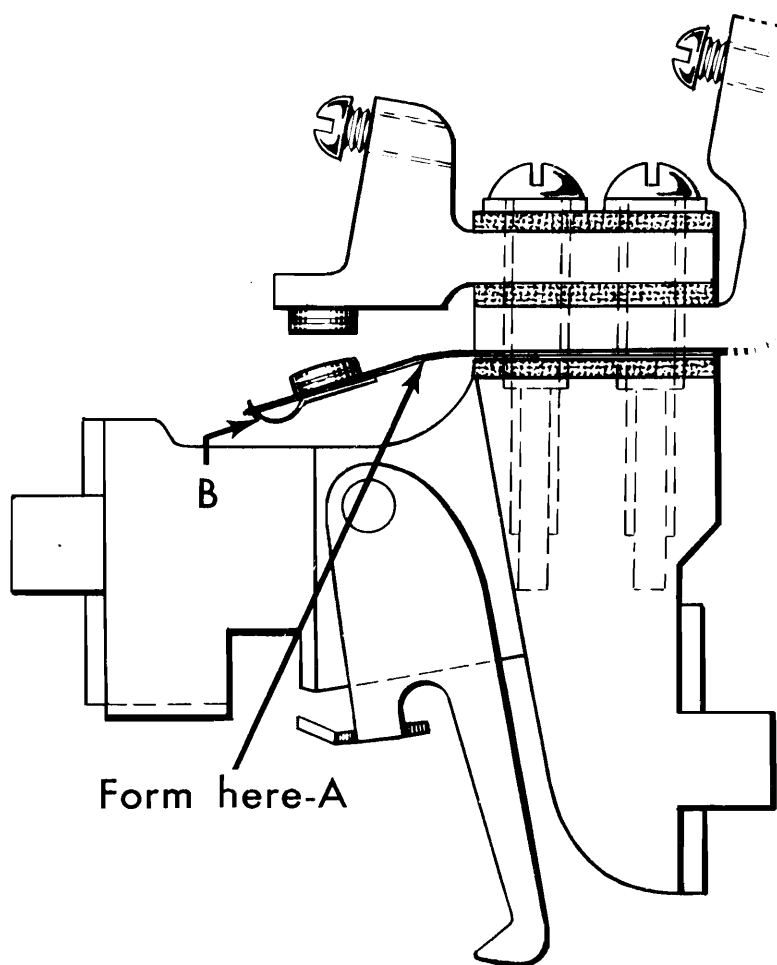

Figure 10. Latching Plunger Circuit Breaker, Adjustment 1

to obtain any desired duration of contact, ranging from a fraction of a cycle point to a complete cycle.

All contacts are closed by a lobe on a bronze cam which operates against the contact plunger and carries it beyond the latching point so that the latch arm may support the contact plunger. The unlatching cam may be adjusted to any position with respect to the periphery of the bronze cam. This cam strikes the latch arm and unlatches the contact plunger. In this manner the contact duration may be adjusted.

1. The lower contact strap should be formed at point A to provide proper tension (Figure 10). At the factory these straps are adjusted so that a force of 160 grams, plus or minus 10 grams, (approximately 6 oz.) applied at the tip of the lower strap, point B, will close the points. To avoid a bouncing condition this tension must be maintained accurately.

2. Place shims beneath the plunger stop plate as required to obtain a .040" to .050" travel of the plunger before latching up occurs (Figure 11). If the contact plunger is overlapped by the latch by an amount equal to the thickness of the latch metal, this should provide the .040" to .050" travel. When the latch arm is unlatched, a pressure of 45 grams plus or minus 5 grams, applied at the point where the unlatching cam operates against the latch arm should move the latch away from the

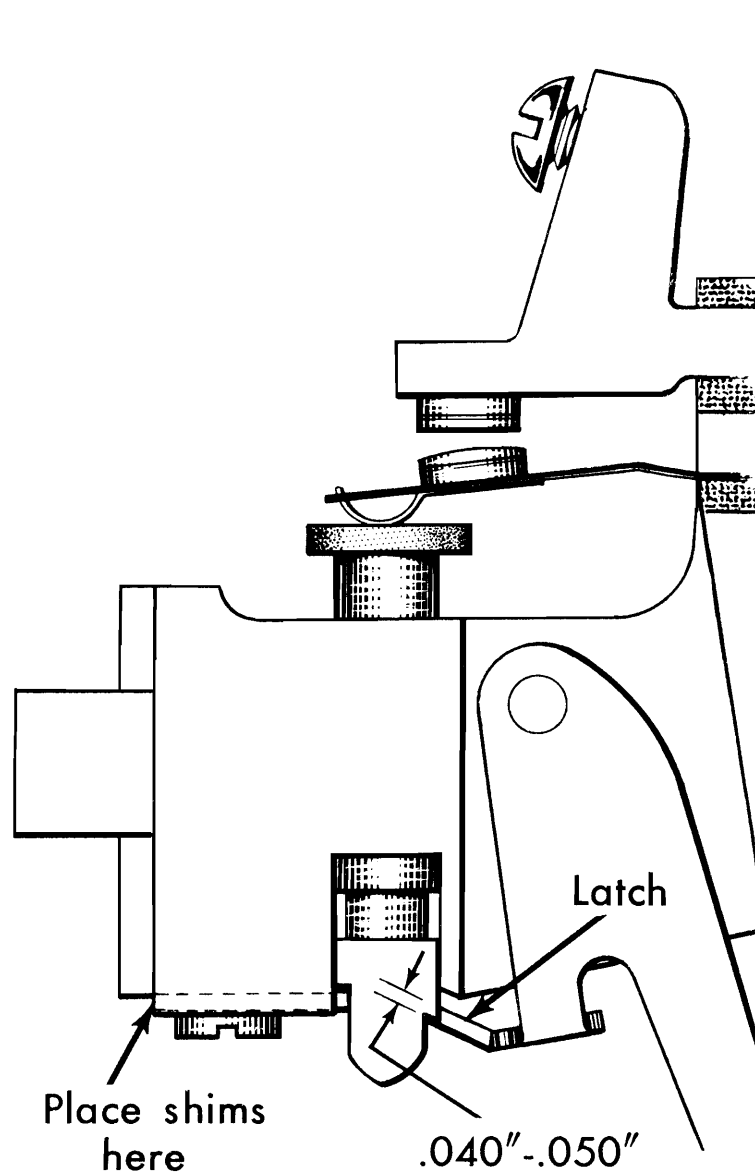

Figure 11. Latching Plunger Circuit Breaker, Adjustment 2

3. Place shims between the lower contact terminal block and the contact strap (Figure 12) to provide a .015" to .018" air gap between the contact points.

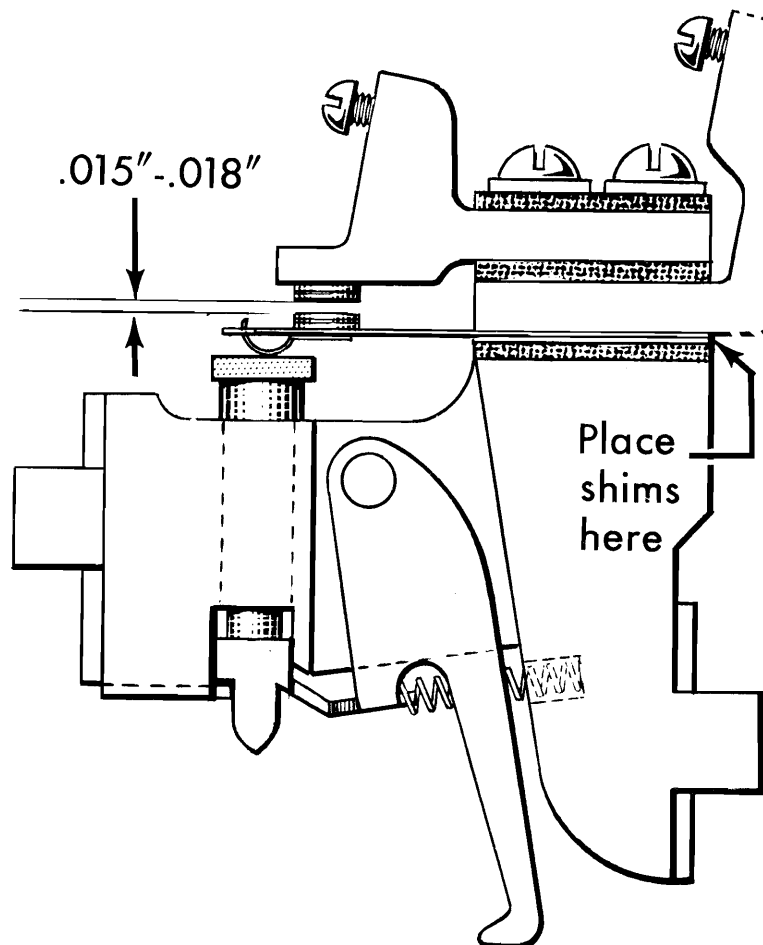

Figure 12. Latching Plunger Circuit Breaker, Adjustment 3

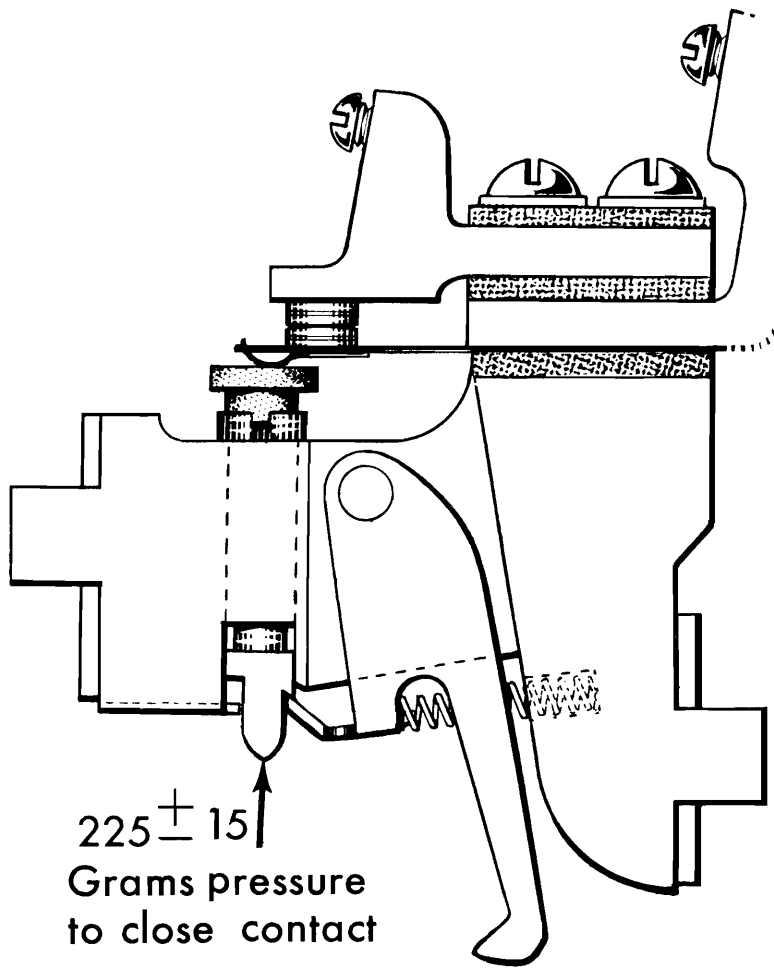

Figure 13. Latching Plunger Circuit Breaker, Adjustment 4

4. Check to be sure that the plunger does not bind (Figure 13). The design of the split bushing is such that the coil spring spreads the bushing to create a drag between the bushing and frame, increasing the pressure required to close the contact from 160 grams (pressure required to compress the spring) to 225 grams (approximately 8 oz.). This friction is used to dampen the rebound when the contact closes. Check to be sure that a maximum of 240 grams applied to the plunger closes the contact.

5. A pressure of 600 grams plus or minus 20 grams, (approximately 21 oz.) on the contact plunger (Figure 14) should be required to compress the plunger spring to the latching point. These values have been tested and found to provide a good operating condition.

6. Locate the cam contact unit on the mounting bar at its extreme limit of travel away from the cam (Figure 15), and with the plunger on the highest point of the cam lobe, advance the adjusting screw until the plunger latches; then advance the screw one-half turn additional to obtain a .010" to .015" movement of the plunger beyond the latch point. This will provide clearance between the low dwell of the cam and the plunger.

7. To adjust the make time of the contact, loosen the screws holding

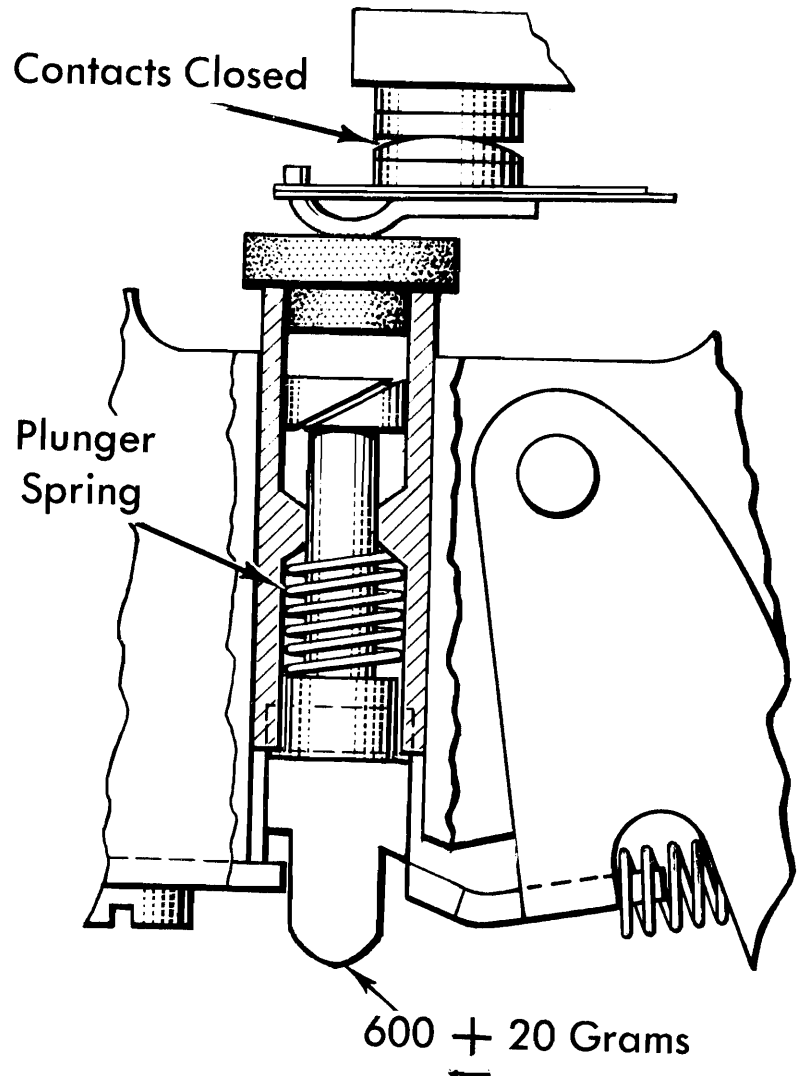

Figure 14. Latching Plunger Circuit Breaker, Adjustment 5

until the cam is just snug on the shaft. Turn the machine to the index point corresponding with the make time of the cam. Move the cam on the shaft in the direction of rotation until the contact just closes. The machine may now be turned to a point where the cam holding screws can be tightened. An accurate adjustment

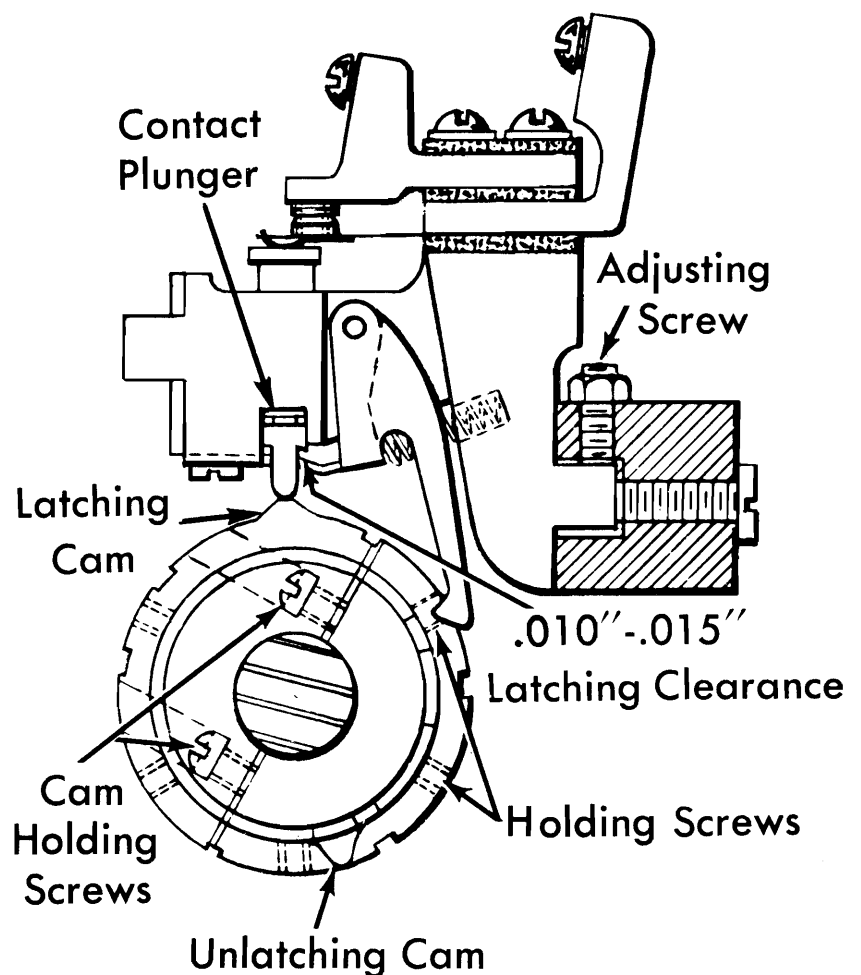

Figure 15. Latching Plunger Circuit

may be obtained by inserting a screwdriver in the slots provided on the periphery of the cam for moving it on the shaft.

8. To adjust the break time of the contact, loosen the contact unlatching cam screws (Figure 15). Turn the machine to the proper index point and move the unlatching cam in its slot until the contact opens. Tighten the holding screws. There are six possible positions for holding screws, only two of which will be used at any one time.

Adjustments — Roller Type

The roller cam follower type of plunger circuit breaker is designed to operate at higher speeds than the standard plunger type. A curved flat spring is fastened to the roller arm. This spring operates the contact plunger which, in turn, operates the lower contact strap.

1. A force of 100 to 150 grams should be required to move the operating point to the point where it contacts the stationary point when measured at the end of the operating strap.

2. The contact air gap should be .027" to .032" when the plunger is resting against the frame (Figure 16). Add or remove shims to obtain this adjustment.

3. When measured at the roller, 475 to 550 grams should be required to close the contacts with a .020" to .030" overtravel (Figure 17).

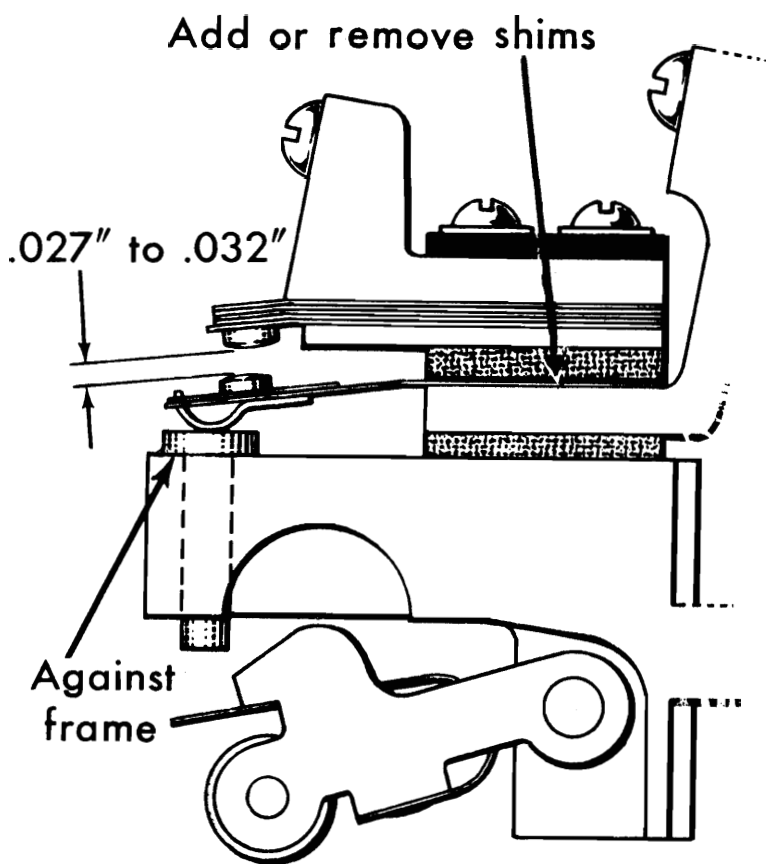

Figure 16. Plunger Circuit Breakers,

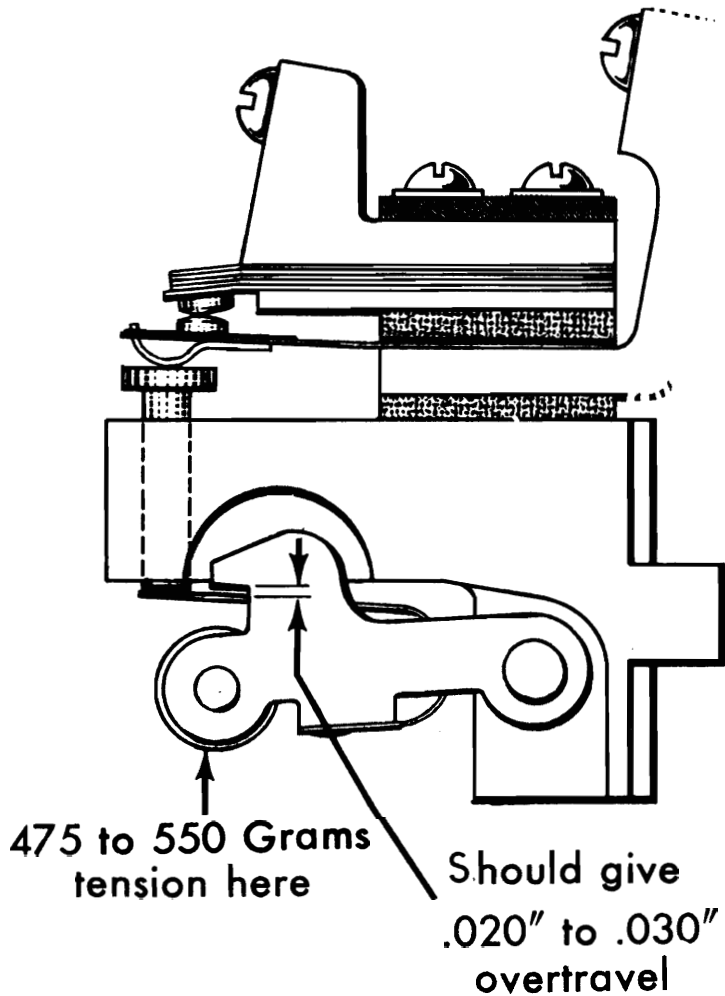

Figure 17. Plunger Circuit Breaker, Roller Cam Follower, Adjustment 3

4. With the circuit breaker assembly attached to the mounting bar by the holding screw (Figure 18), turn in on the adjustment screw to obtain a contact air gap of .017" to .022" when in the low dwell of the cam.

5. When positioning the dilecto cams, be careful not to tighten the cam holding screws too severely as their walls may crack.

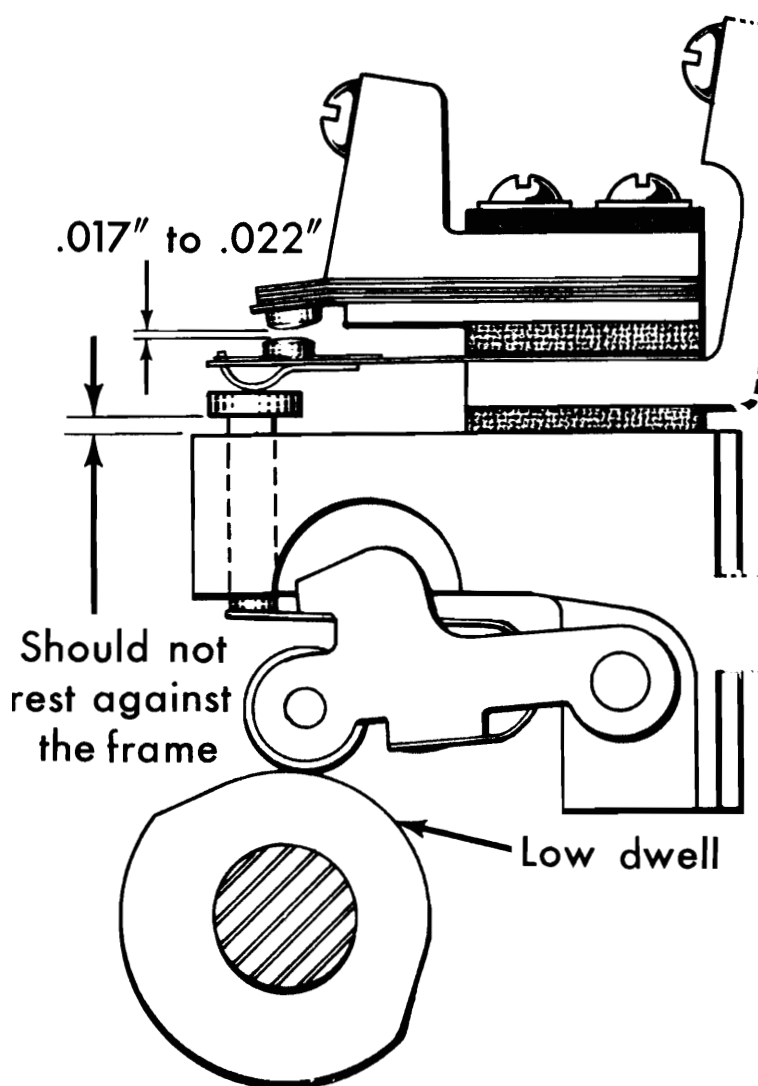

Figure 18. Plunger Circuit Breaker,

MASTER CIRCUIT BREAKERS, TYPE 407 PREVENTIVE MAINTENANCE

Cleaning

Wipe away any oil around the circuit breaker points.

Wipe off the insulating plates.

Lubrication

Check to see that the Bijur system is furnishing oil to the contact bracket pivot point.

The cam follower rollers and the cam surfaces are lubricated by capillary action from the pivot point of the contact bracket assembly and by the oil vapor that fills the circuit breaker housing. IBM 17 should be used on the surfaces of the cams and rollers to supplement this means of lubrication.

3. A drop of IBM 9 should be applied to the roller bearings.

4. A small amount of IBM 21 should be applied to the point of sliding contact between the contact point bar and the contact cage.

5. Avoid lubrication.

Inspection

The timing of the circuit breakers should be checked dynamically. The transfer of metal from one point to the other will shorten the circuit breaker impulse. Machine failures can occur when the master circuit breakers have lost more than one degree duration. When this occurs, the loss of contact material is such that there is insufficient material remaining to warrant any attempt at readjustment of the contacts. Therefore, contact replacement should be made when there is sufficient loss of material to shorten the master circuit breaker impulse by one degree.

Adjustment

The contacts of the Type 407 master circuit breakers (Figure 19) are wired in series. It is imperative that the utmost care be exercised when adjusting this unit.

The following procedure should be followed when installing new contact points in the master circuit breakers:

1. Install the new contact points, four of part 203866 and two of part 203894.

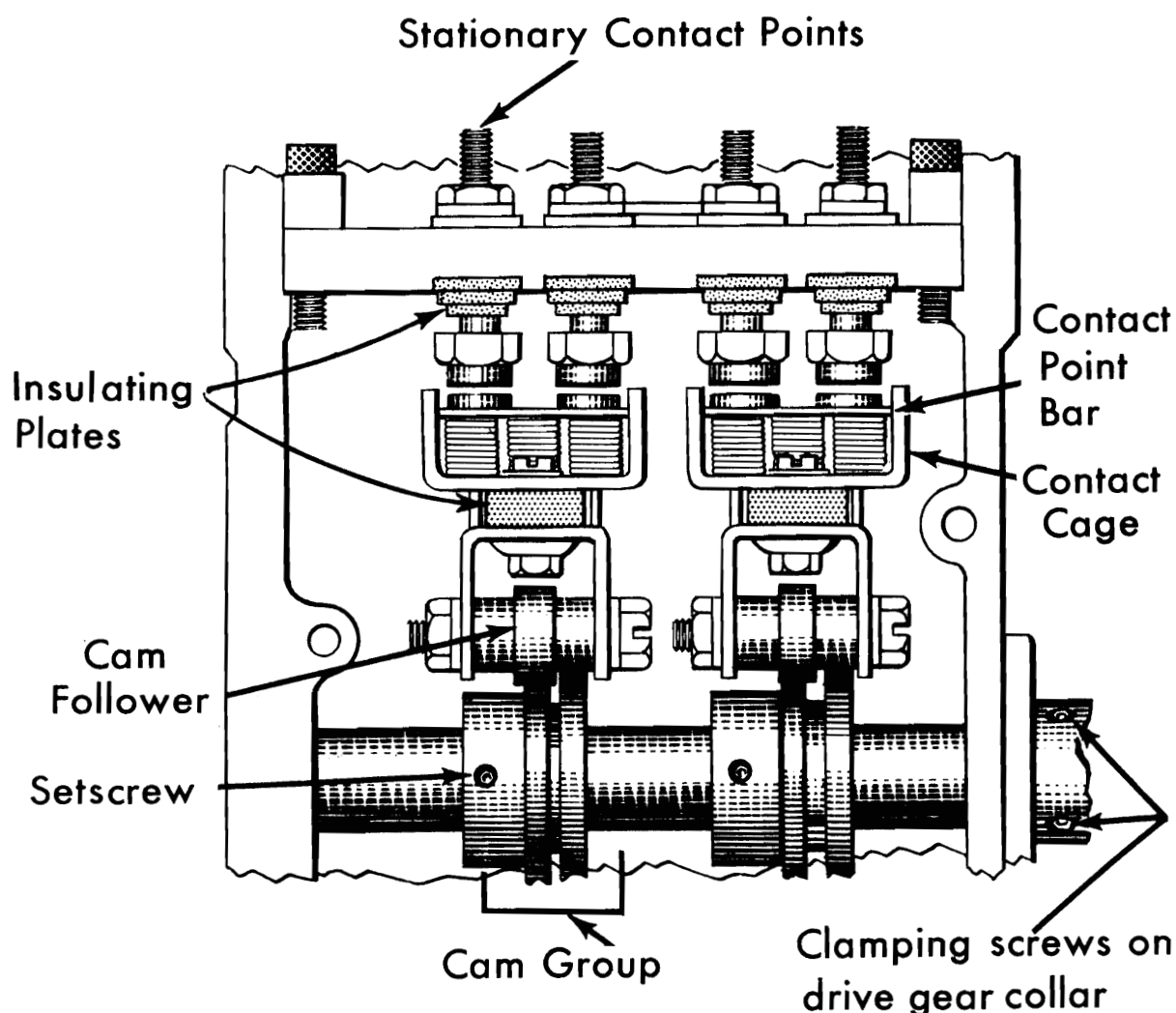

2. With a feeler gauge establish a .056" air gap between the upper and lower points when the cam followers are on the low dwell of the complementary cams.

3. Connect the first dynamic timer light from CB1 to the common contact cage, and the second light from CB2 to the common contact cage. Turn the machine very slowly, using the front crank, and adjust contacts 1 and 2 so that the timer lights make and break together and so that a duration of ten degrees is obtained. This is accomplished by varying the air gap by adjusting the stationary contacts. It is extremely important that the contacts make exactly together and break exactly together. To insure this condition, extreme care must be used and the machines must be cranked very slowly. The time of make and break with respect to the index time is not important at this time.

4. Connect timer light from CB3 and 4 to common contact cage as in step 2, adjust for ten degrees duration, and for the contacts to make and to break exactly together. As with CB1 and 2 it is necessary that extreme care be used to insure that the contacts make and break together as accurately as the adjustment can be made, and that the contacts have exactly a 10 degree duration.

5. If the contact points being adjusted have flat points, they must be carefully straightened so that all contact surfaces are exactly parallel. In the event flat contacts are used and it is necessary to form them to make contact surfaces parallel, it will be necessary to repeat steps 2, 3, and 4. Then recheck for parallelism. Contacts presently shipped have round points which will eliminate the necessity for this step.

6. The difference between the make of CB1 and 2 and the break of CB3 and 4 must be exactly eight degrees. This is set by loosening the setscrews for the complementary cams and setting CB1 and 2 so that they make exactly at 172 degrees, plus 0 degrees minus $\frac{1}{2}$ degree. CB3 and 4 are to be similarly adjusted so that they break at exactly 180 degrees, plus 0 degrees minus $\frac{1}{2}$ degree. Use care to insure accurate adjustment and to keep the correct alignment between the cams and cam followers. Use a timer light across the points and turn the machine slowly with the crank when

7. Check the adjustment dynamically and re-adjust if necessary for an eight-degree pulse at 172 degrees, plus 0 degrees, minus $\frac{1}{2}$ degree, to 180 degrees, plus 0 degrees, minus $\frac{1}{2}$ degree. Check the impulse at the other cycle points. However, *slight variations* at other points on the index can be ignored as there will be some slight variation due to manufacturing tolerances on the lobes of the cams.

SPRING STRAP CAM CONTRACT

Preventive Maintenance

Clean the cam surfaces and contacts of all grease oil and dirt using an authorized solvent. When a point is badly burned, replace the contact strap assembly.

Check the contact points to see if they are loose in the strap. They can be tightened by peening the point.

Stone the points to a flat surface using a flexstone or trimite paper. After stoning or cleaning the contact points, they must be thoroughly polished with a burnishing tool.

Make certain that the contact surfaces are parallel and that they meet squarely. Check the screws in the contact pile up for tightness.

Lubrication

IBM 17

- (1) A light film should be applied to the cam surface.

Adjustments

There are two types of cam contacts commonly referred to as *make* or *break* contacts. They are identified by their position after the operating strap falls off the high dwell of the cam. When the operating strap falls off the high dwell of the cam and the contact opens, a break contact is designated. When the operating strap falls off the high dwell of the cam and the contact closes, a make contact is designated.

The plastic cams used to operate the contacts are stamped with a fraction indicating the size of the cam. The size is given in fourteenths or a fraction of $\frac{1}{14}$, and it indicates the proportion of the circumference that is high (Figure 20). Thus, a $\frac{4}{14}$ cam has approximately $\frac{4}{14}$ of its circumference high and $\frac{10}{14}$ low. When used with a break contact, such a contact will be closed $\frac{4}{14}$ when the operating strap is on the

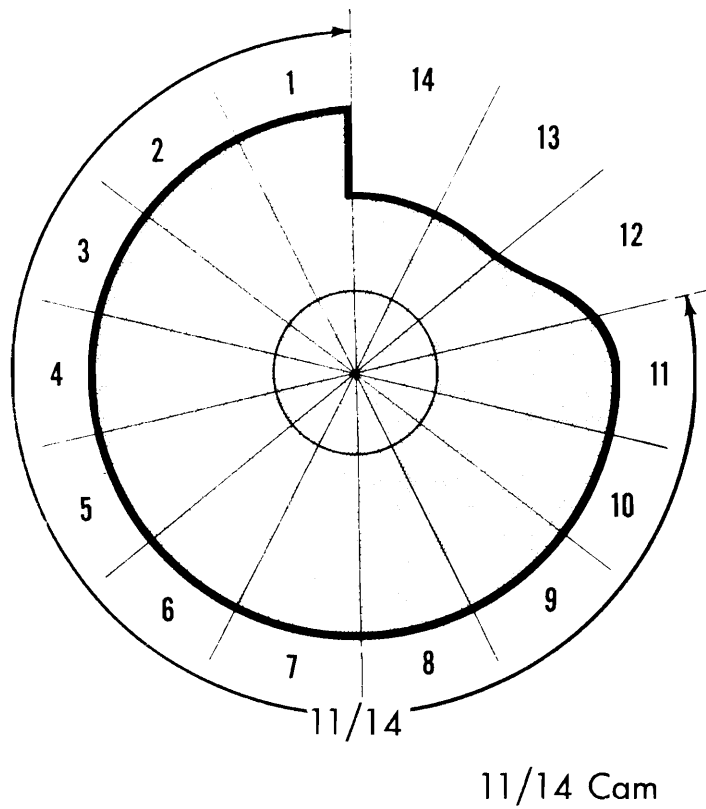

Figure 20. Contact Cam

open 10/14 when on the low dwell of the cam. If a make contact is used, the contact will be open for 4/14 and closed for 10/14 of the circumference of the cam. A make contact is open when the operating strap is on the high portion of the cam.

1. Align the contact points for full contact by loosening the contact mounting screws and shifting straps for proper alignment. Be sure the screws are tightened.

2. Adjust the make contact by bending the non-operating strap for an air gap of 1/32" between points when the operating strap is on the high dwell of the cam (Figure 21). The operating strap should have sufficient tension to insure good contact when the points are closed.

3. Adjust the break contact by bending the non-operating contact support for 1/32" rise of the non-operating strap off its support when the operating strap is on the high dwell of the cam (Figure 21). When the operating strap drops off the high dwell of the cam, there should be at least 1/16" air gap between the points. There should not be too much tension on the operating strap. Too much tension will cause noisy operation and excessive wear on the cams.

4. Adjust the timing of the contacts by loosening the cam setscrews and shifting the cam on the shaft (Figure 21). The timing of the individual contact is obtained from the timing chart which accompanies the machine. Make contacts are timed for the making point (the point at which the contact strap falls off the high dwell of the cam). Break contacts are timed for the proper breaking point, according to the timing chart (the point at which the operating strap falls off the high dwell of the cam).

